

Vacuum Pad/Bowl Shape with Non-slip Feature

Ø 32, Ø 40, Ø 50, Ø 63, Ø 80, Ø 100

New

RoHS

Non-slip special ribs

Diagonal ribs are radially arranged to secure the gripping force in all directions.

- Prevents workpiece slippage
- Secure adsorbing and transferring are possible.

Bowl shape with excellent flexibility

Curved workpieces can also be adsorbed.

Horizontal holding force: 231 N (Pad diameter Ø 80)*1

Suitable for high-temperature workpieces (200 °C)*1

*1 For details, refer to the specifications on page 2.

Material: FS61 (Fluoro-based rubber)
improves abrasion resistance

* More than twice the abrasion resistance of
SMC's urethane pads

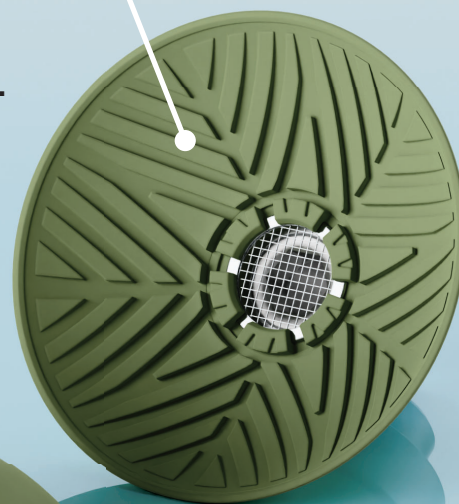

Suitable for workpieces with oil film

As oil is ejected to the grooves between special ribs, the lateral slipping of workpiece can be suppressed even on a steel plate with oil film.

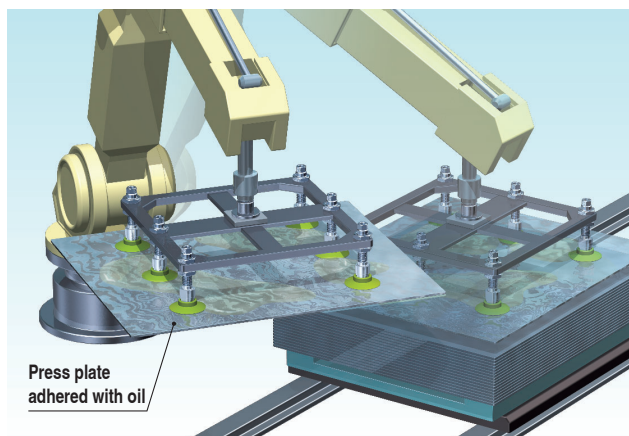
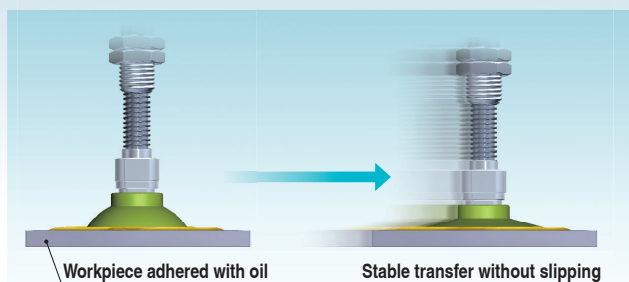

The bowl shape can handle curved workpieces.

The pad follows the workpiece shape, making stable adsorption possible.

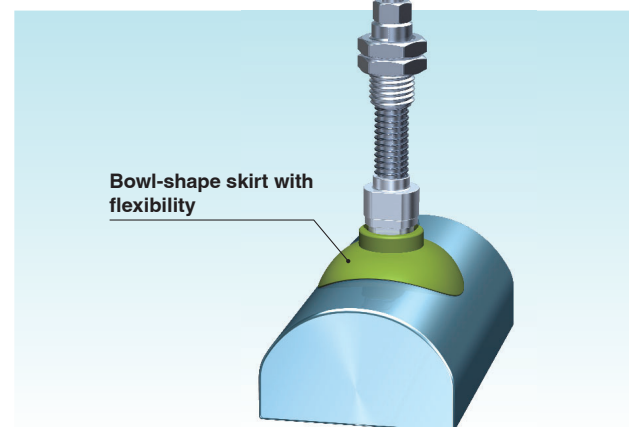

ZP3M Series



CAT.EUS100-147A-UK

Vacuum Pad/Bowl Shape with Non-slip Feature *ZP3M Series*

Mesh filter (Option)

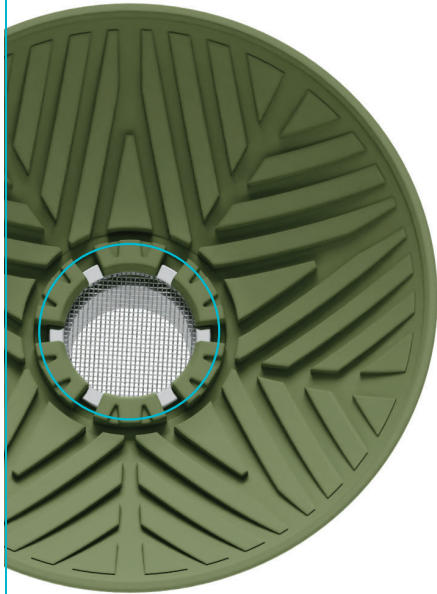

- Reduced suction of foreign matter into the vacuum pump and ejector
- Detachable
- Opening: 250 μm

Installation from below is possible.



Insert-molded pad to prevent the pad from falling out of the adapter

Variations

Type	Mounting	Vacuum inlet direction	Connection		Vacuum inlet		
			Type	Size		Size	
				Pad diameter: $\varnothing 32$ to $\varnothing 50$	Pad diameter: $\varnothing 63$ to $\varnothing 100$	Pad diameter: $\varnothing 32$ to $\varnothing 50$	Pad diameter: $\varnothing 63$ to $\varnothing 100$
With adapter 	Direct mounting	Vertical	Male thread	M10 x 1.0	M16 x 1.5	Use the connection thread.	
				G1/4			
			Female thread	M14 x 1.0		G1/4	G3/8
Square adapter		$\square 31.8$					
With buffer 	Plate mounting	Vertical	Male thread	M18 x 1.5	M22 x 1.5	M5 x 0.8	Rc1/8
		Lateral					

Vacuum Pad/Bowl Shape with Non-slip Feature

ZP3M Series

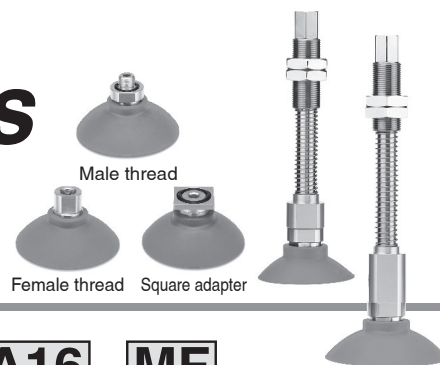

How to Order

With adapter

ZP3M - T 63 R FS - A16 - MF

With buffer

ZP3M - T 63 R FS JB 30 - MF

① Bowl shape ② With buffer

① Vacuum inlet direction

T	Vertical
Y	Lateral

④ Buffer stroke

Stroke [mm]	Pad size	
	All sizes	
10	●	
30	●	
50	●	

⑥ Mesh filter

—	None
MF	With mesh filter

Mesh filter unit

Part no.	Pad diameter	
	○ 32 to ○ 50	○ 63 to ○ 100
ZPMF-60-D13	●	—
ZPMF-60-D18	—	●

② Pad diameter

32	○ 32
40	○ 40
50	○ 50
63	○ 63
80	○ 80
100	○ 100

③ Material

Symbol	Material	Colour
FS	FS61 (Fluoro-based rubber)	Green

⑤ Connection thread and type

Mounting	Type	Symbol	Size	Pad diameter	
				○ 32 to ○ 50	○ 63 to ○ 100
Direct mounting	Male thread	A10	M10 x 1.0	●	—
		A16	M16 x 1.5	—	●
		AG02	G1/4	●	●
	Female thread	B14	M14 x 1.0	●	●
		BG02	G1/4	●	●
		BG03	G3/8	●	●
	Square adapter	S32	□31.8	●	●

* The adapter and pad are adhered to each other and cannot be disassembled.

Specifications

Pad Material

Material	FS61 (Fluoro-based rubber)
Colour of rubber	Green
Rubber hardness (Shore A: ±5°)	60
Operating temperature range*1	0 °C to 200 °C
Ambient temperature	0 °C to 150 °C

*1 Surface temperature of the workpiece to be adsorbed

Adapter Specifications

Connection	Male thread		Female thread		Square adapter
Pad diameter	○ 32 to ○ 50	○ 63 to ○ 100	○ 32 to ○ 50	○ 63 to ○ 100	○ 32 to ○ 100
Size	M10 x 1.0 G1/4	M16 x 1.5 G1/4	M14 x 1.0 G1/4 G3/8		□31.8
Vacuum inlet	Use the connection thread and type.				

Buffer Specifications

Pad diameter	○ 32 to ○ 50			○ 63 to ○ 100				
	Non-rotating specification	JB: Rotating, With bushing			JB: Rotating, With bushing			
Stroke [mm]	10	30	50	10	30	50		
Connection thread	M18 x 1.5			M22 x 1.5				
Spring reactive force	At 0 stroke			10.0				
	At full stroke			6.5	8.5	10.5	11.5	13.5

Pad Specifications

Part no.	Horizontal holding force [N]*1		Minimum curvature radius for adsorption [mm]*2
	Without oil	With oil	
ZP3M-T32RFS	47	21	14
ZP3M-T40RFS	81	53	15
ZP3M-T50RFS	111	74	20
ZP3M-T63RFS	170	108	27.5
ZP3M-T80RFS	231	178	36
ZP3M-T100RFS	387	224	46

*1 These are actual measurement values when flat workpieces were adsorbed and are not guaranteed values. (According to the SMC test)

The values vary depending on the conditions (shape, surface roughness, oil type, oil amount, and other conditions) of the workpiece.

*2 These are actual measurement values when cylindrical workpieces were adsorbed and are not guaranteed values. (According to the SMC test)

Mesh Filter Specifications

Mesh filter	60
Opening	250 μm

Buffer assembly part no. p. 7

ZP3M Series

Dimensions/Models

With adapter Direct mounting type (Male thread)

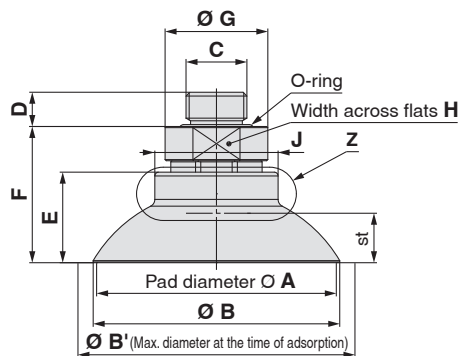

Section Z

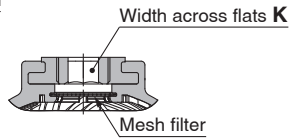

ZP3M - T **63** R **FS** - **A16** - **MF**



		Pad diameter [mm]	
		Ø 32 to Ø 50	Ø 63 to Ø 100
A10	M10 x 1.0	○	-
A16	M16 x 1.5	-	○
AG02	G1/4	○	○

		Model				A	B	B ¹ *2	C	D	E	F	G	H	J	K	st*2	Min. opening hole size of the adapter	Weight [g]
Vacuum inlet direction	1 Pad diameter	Form	2 Material *1	3 Connection thread	4 Mesh filter														
ZP3M	T	R	FS	-	MF	32	33.2	38.3	M10 x 1.0	7	14.3	23.8	20	17	20.4	5	6	Ø 5	16.1
									G1/4	6.5		24.1	25	22					24.5
						40	41.3	47.8	M10 x 1.0	7	17.8	27.3	20	17	21	5	8.4	Ø 5	17.3
									G1/4	6.5		27.6	25	22					25.7
						50	51.6	58.6	M10 x 1.0	7	19.4	28.9	20	17	21.4	5	10.4	Ø 5	21.1
									G1/4	6.5		29.2	25	22					29.5
	63	64.8	73.3	M16 x 1.5	9	24.1	36.1	27	24	32.4	8	12	Ø 8	47.1					
				G1/4	6.5		35.6							Ø 6	46.7				
	80	81.8	92.2	M16 x 1.5	9	27.1	39.1	27	24	33	8	14.4	Ø 8		61.3				
				G1/4	6.5		38.6							Ø 6	60.9				
	100	102.2	113.4	M16 x 1.5	9	33.9	45.9	27	24	34.4	8	20.1	Ø 8		96.7				
				G1/4	6.5		45.4							Ø 6	100.4				

*1 FS: FS61 (Fluoro-based rubber)

*2 B¹: Maximum pad diameter at the time of adsorption, st: The stroke is a guide value at the setting vacuum pressure of -90 kPa.

With adapter Direct mounting type (Female thread)

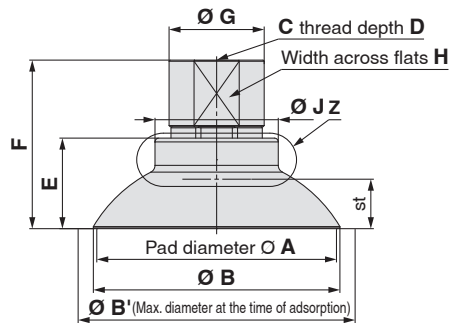

Section Z

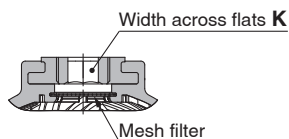

ZP3M - T **63** R **FS** - **B14** - **MF**



		Pad diameter [mm]	
		Ø 32 to Ø 100	
B14	M14 x 1.0	○	
BG02	G1/4	○	
BG03	G3/8	○	

		Model				A	B	B ¹ *2	C	D	E	F	G	H	J	K	st*2	Min. opening hole size of the adapter	Weight [g]	
Vacuum inlet direction	1 Pad diameter	Form	2 Material *1	3 Connection thread	4 Mesh filter															
ZP3M	T	R	FS	-	MF	32	33.2	38.3	M14 x 1.0	8	14.3	31.6	23	19	20.4	5	6	Ø 5	20.9	
									G1/4	11		33.6	20	17					19.1	
						40	41.3	47.8	M14 x 1.0	8	17.8	35.1	23	19	21	5	8.4	Ø 5	22.1	
									G1/4	11		37.1	20	17					20.3	
						50	51.6	58.6	M14 x 1.0	8	19.4	36.7	23	19	21.4	5	10.4	Ø 5	25.9	
									G1/4	11		38.7	20	17					24.1	
	63	64.8	73.3	M14 x 1.0	8	24.1	41.6	23	19	32.4	8	12	Ø 8	42.2						
				G1/4	11		42.6	22	19					42.5						
	80	81.8	92.2	M14 x 1.0	8	27.1	44.6	23	19	33	8	14.4	Ø 8	56.4						
				G1/4	11		45.6	22	19					56.7						
	100	102.2	113.4	M14 x 1.0	8	33.9	51.4	23	19	34.4	8	20.1	Ø 8	92.3						
				G1/4	11		52.4	22	19					92.6						
																				96.5

*1 FS: FS61 (Fluoro-based rubber)

*2 B¹: Maximum pad diameter at the time of adsorption, st: The stroke is a guide value at the setting vacuum pressure of -90 kPa.

Dimensions/Models

With adapter Direct mounting type (Square adapter)

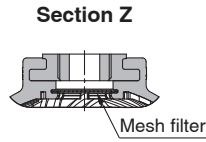
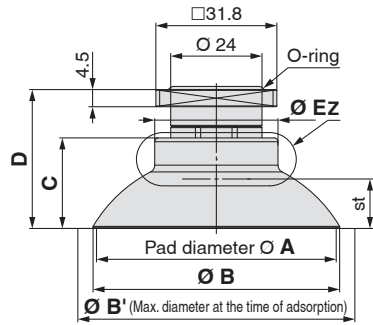

ZP3M - T **1** **63** R **2** **FS** - S32 - **3** **MF**



Model							A	B	B ¹ *2	C	D	E	st*2	Min. opening hole size of the adapter	Weight [g]
Vacuum inlet direction	1 Pad diameter	Form	2 Material *1	Connection thread	3 Mesh filter										
ZP3M	T	R	FS	S32	MF	32	33.2	38.3	14.3	26.3	20.4	6	Ø 5	26.1	
						40	41.3	47.8	17.8	29.8	21	8.4	Ø 5	27.3	
						50	51.6	58.6	19.4	31.4	21.4	10.4	Ø 5	31.1	
						63	64.8	73.3	24.1	36.8	32.4	12	Ø 8	48.7	
						80	81.8	92.2	27.1	39.8	33	14.4	Ø 8	62.8	
						100	102.2	113.4	33.9	46.6	34.4	20.1	Ø 8	97.4	

*1 FS: FS61 (Fluoro-based rubber)

*2 B': Maximum pad diameter at the time of adsorption, st: The stroke is a guide value at the setting vacuum pressure of -90 kPa.

Square adapter mounting groove dimensions (Recommended)

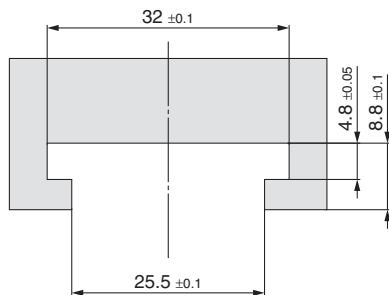

* For details on how to use the square adapter, refer to "Mounting" on page 9.

ZP3M Series

Dimensions/Models

With buffer Plate mounting type (Vacuum inlet direction: Vertical)

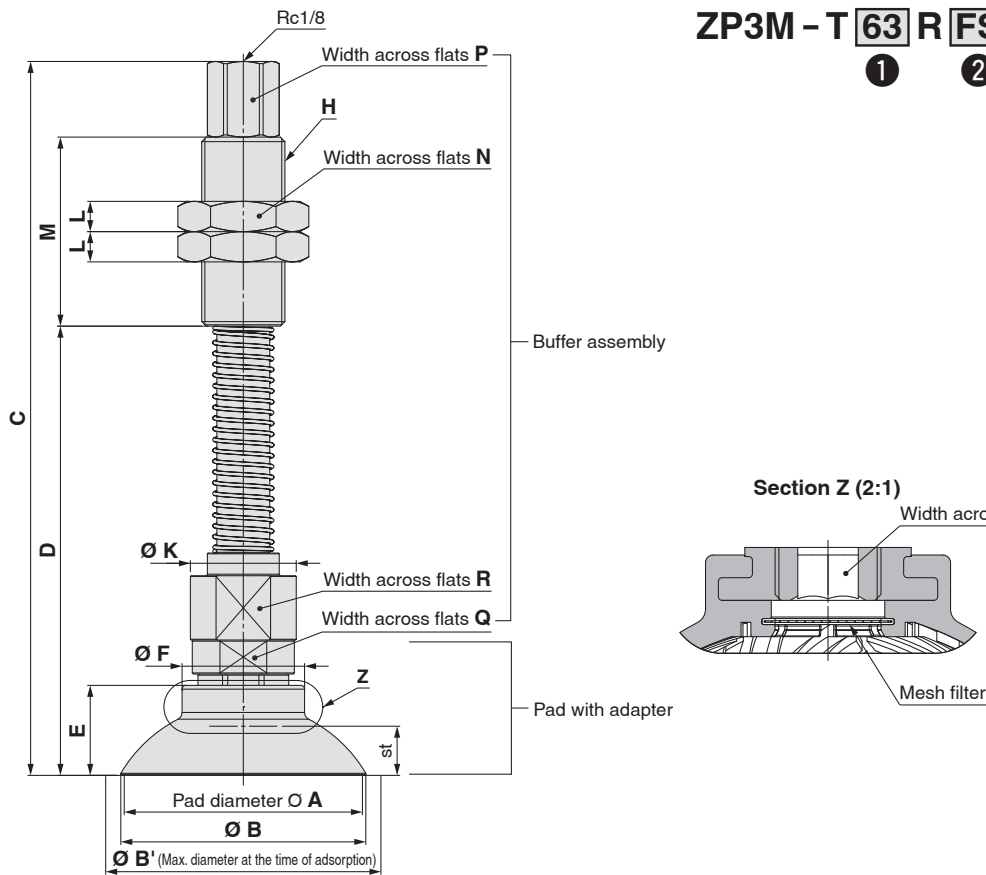

		Model																					Min. opening hole size of the adapter	Weight [g]		
Vacuum inlet direction	① Pad diameter	Form	② Material *1	③ Buffer spec.	④ Buffer stroke	⑤ Mesh filter	A	B	B ¹ *2	C	D	E	F	H	J	K	L	M	N	P	Q	R			st*2	
ZP3M	T	32	R	FS	JB	10	63.5	64.8	73.3	123.3	71.3	14.3	20.4	M18 x 1.5	5	19	11	35	27	14	17	16	8.4	6	O 3	205
						30				148.3	96.3															219.5
						50				168.3	116.3															231
						10				126.8	74.8															206.2
						30				151.8	99.8															220.7
						50				171.8	119.8															232.2
		40	10	128.4	76.4	210																				
			30	153.4	101.4	224.5																				
			50	173.4	121.4	236																				
			10	164.1	94.1	355																				
			30	189.1	119.1	383.8																				
			50	209.1	139.1	406.7																				
	50	10	167.1	97.1	369.2																					
		30	192.1	122.1	397.9																					
		50	212.1	142.1	420.9																					
		10	173.9	103.9	404.6																					
		30	198.9	128.9	433.4																					
		50	218.9	148.9	456.3																					
	63	R	FS	JB	MF	10	80.6	81.8	92.2	164.1	94.1	27.1	33	M22 x 1.5	8	28	8	50	30	17	24	24	14.4	20.1	O 4	355
						30				189.1	119.1															383.8
						50				209.1	139.1															406.7
						10				167.1	97.1															369.2
						30				192.1	122.1															397.9
						50				212.1	142.1															420.9
80	R	FS	JB	MF	10	100	102.2	113.4	173.9	103.9	33.9	34.4	M22 x 1.5	8	28	8	50	30	17	24	24	14.4	20.1	O 4	404.6	
					30				198.9	128.9															433.4	
					50				218.9	148.9															456.3	
					10				167.1	97.1															369.2	
					30				192.1	122.1															397.9	
					50				212.1	142.1															420.9	
100	R	FS	JB	MF	10	100	102.2	113.4	173.9	103.9	33.9	34.4	M22 x 1.5	8	28	8	50	30	17	24	24	14.4	20.1	O 4	404.6	
					30				198.9	128.9															433.4	
					50				218.9	148.9															456.3	
					10				167.1	97.1															369.2	
					30				192.1	122.1															397.9	
					50				212.1	142.1															420.9	

*1 FS: FS61 (Fluoro-based rubber)

*2 B': Maximum pad diameter at the time of adsorption, st: The stroke is a guide value at the setting vacuum pressure of -90 kPa.

ZP3M Series

Mounting Bracket Assembly

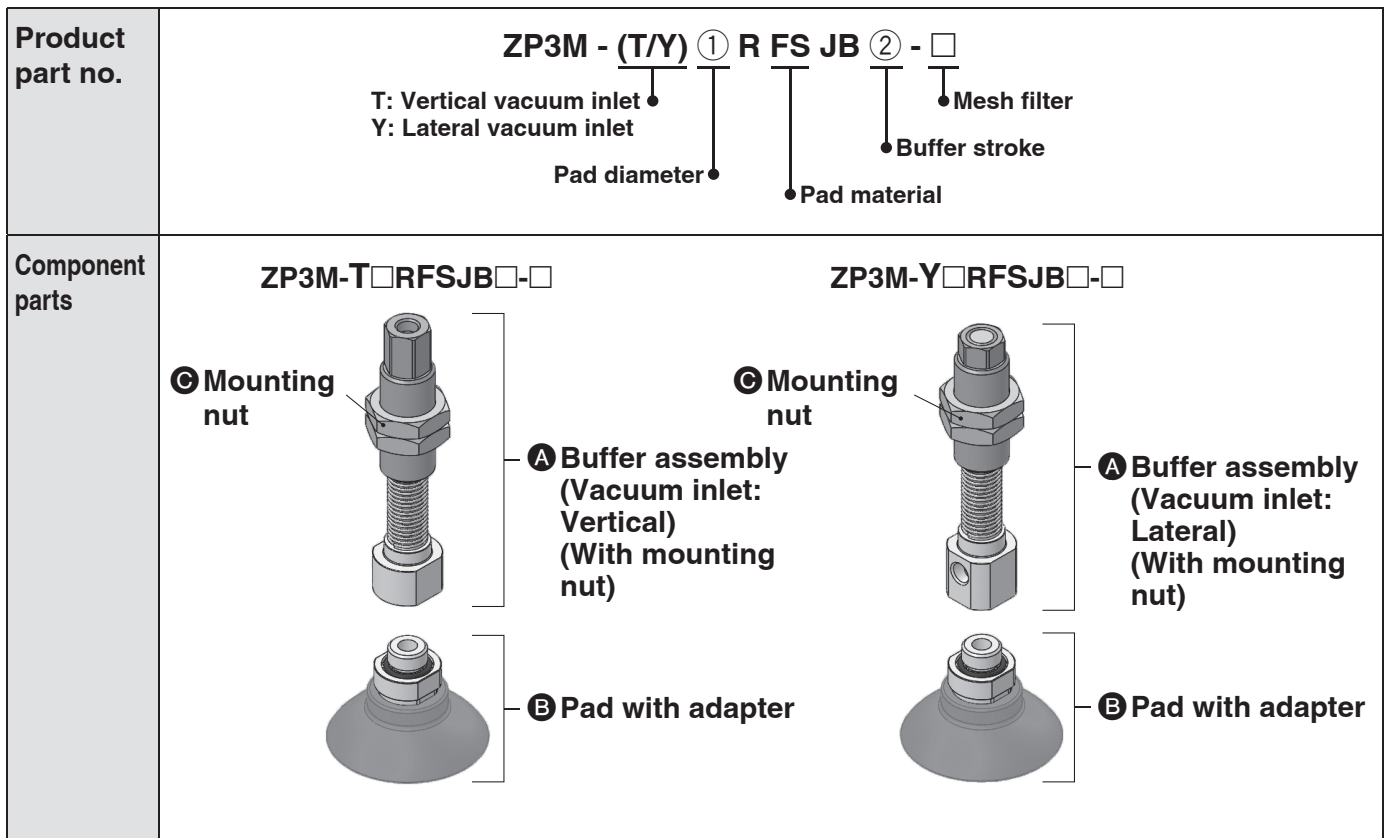

		Symbol	① Pad diameter					
			32	40	50	63	80	100
A Buffer assembly (With mounting nut)	② Buffer stroke	10	ZP3EB-(T/Y)1JB②			ZP3EB-(T/Y)2JB②		
		30						
		50						
B Pad with adapter	M10 x 1.0	ZP3M-T32RFS-A10-□	ZP3M-T40RFS-A10-□	ZP3M-T50RFS-A10-□	—			
	M16 x 1.5	—			ZP3M-T63RFS-A16-□	ZP3M-T80RFS-A16-□	ZP3M-T100RFS-A16-□	
C Mounting nut (Single unit)	M18 x 1.5	ZPNA-M18				—		
	M22 x 1.5	—				ZPNA-M22		

[Buffer assembly part number example]

Product part no. **ZP3M - T63RFS JB 10**

Buffer assembly **ZP3EB - T2 JB 10**

② Buffer stroke



ZP3M Series

Vacuum Pad/Specific Product Precautions

Be sure to read this before handling the products. Refer to the back cover for safety instructions. For vacuum equipment precautions, refer to the “Handling Precautions for SMC Products” and the “Operation Manual” on the SMC website: <https://www.smcworld.com>

Design

1. Before use, please check the transfer conditions with the customer’s actual equipment.

The transfer ability varies depending on the workpiece material, the friction between the pad and workpiece, moment, wind, vibration, etc. Testing with the customer’s actual equipment is necessary.

2. In cases where the workpieces are heavy or dangerous objects, etc., take measures to address a possible loss of adsorption force (installation of a drop prevention guide, etc.).

3. The oil, chemical, and other substances adhered to the workpiece may not be suitable for the pad material.

Before using this product, sufficiently verify the workpieces in your operating environment.

Mounting

1. When mounting the product, tighten with the tightening torque shown in the table below.

If excessive or insufficient tightening torque is applied, sealing failure or loose screws may result.

When using a product equipped with a buffer, if the buffer is tightened to a torque beyond the appropriate tightening torque range, the buffer may malfunction.

With Adapter (Male thread type)

Model	Connection thread size	Proper tightening torque [N·m]
ZP3M-T□RFS-A10-□	M10 x 1.0	8 to 10
ZP3M-T□RFS-A16-□	M16 x 1.5	13 to 15
ZP3M-T□RFS-AG02-□	G1/4	8 to 12

With Adapter (Female thread type)

Model	Connection thread size	Proper tightening torque [N·m]
ZP3M-T□RFS-B14-□	M14 x 1.0	11 to 13
ZP3M-T□RFS-BG02-□	G1/4	8 to 12
ZP3M-T□RFS-BG03-□	G3/8	15 to 20

With Buffer

Model	Connection thread size	Proper tightening torque [N·m]
ZP3M-(T/Y)□RFS-JB□-□	M18 x 1.5	28 to 32
	M22 x 1.5	45 to 50

2. How to use the square adapter

Use the square adapter by inserting it to an attachment you prepare. If it is difficult to insert the square adapter, apply grease to the O-ring. Prepare retaining measures by yourself.

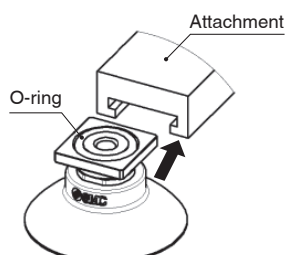

Handling

1. Depending on the type of oil or foreign matter, the mesh filter may be clogged at an early stage.

Before using this product, sufficiently verify the mesh filter in your operating environment.

2. Periodically inspect the mesh filter.

An adsorbing malfunction may be caused by the clogging of the mesh filter.

3. When the vacuum pad is pressed, make sure it stays within the stroke range.

If this product is used with a stroke exceeding the maximum stroke, the pad may be broken or may reach the end of its service life earlier.

4. Vacuum pads are consumable. Please replace them when cracks or deformation is confirmed during periodic maintenance.

5. The workpiece size must be equal to or greater than the minimum curvature radius for adsorption.



If the workpiece size is smaller than the minimum curvature radius for adsorption, an adsorbing malfunction may occur.

6. As the adapter and pad are adhered to each other, they cannot be disassembled.

7. When adsorbing a plane, the pad skirt may be entrained depending on the workpiece with rough friction surface. Before using this product, sufficiently verify the adsorbing condition.

Safety Instructions

These safety instructions are intended to prevent hazardous situations and/or equipment damage. These instructions indicate the level of potential hazard with the labels of “Caution,” “Warning” or “Danger.” They are all important notes for safety and must be followed in addition to International Standards (ISO/IEC)¹⁾, and other safety regulations.

-  **Caution:** **Caution** indicates a hazard with a low level of risk which, if not avoided, could result in minor or moderate injury.
-  **Warning:** **Warning** indicates a hazard with a medium level of risk which, if not avoided, could result in death or serious injury.
-  **Danger:** **Danger** indicates a hazard with a high level of risk which, if not avoided, will result in death or serious injury.

- 1) ISO 4414: Pneumatic fluid power – General rules relating to systems.
ISO 4413: Hydraulic fluid power – General rules relating to systems.
IEC 60204-1: Safety of machinery – Electrical equipment of machines.
(Part 1: General requirements)
ISO 10218-1: Manipulating industrial robots - Safety.
etc.

Warning

1. The compatibility of the product is the responsibility of the person who designs the equipment or decides its specifications.

Since the product specified here is used under various operating conditions, its compatibility with specific equipment must be decided by the person who designs the equipment or decides its specifications based on necessary analysis and test results. The expected performance and safety assurance of the equipment will be the responsibility of the person who has determined its compatibility with the product. This person should also continuously review all specifications of the product referring to its latest catalogue information, with a view to giving due consideration to any possibility of equipment failure when configuring the equipment.

2. Only personnel with appropriate training should operate machinery and equipment.

The product specified here may become unsafe if handled incorrectly. The assembly, operation and maintenance of machines or equipment including our products must be performed by an operator who is appropriately trained and experienced.

3. Do not service or attempt to remove product and machinery/equipment until safety is confirmed.

1. The inspection and maintenance of machinery/equipment should only be performed after measures to prevent falling or runaway of the driven objects have been confirmed.
2. When the product is to be removed, confirm that the safety measures as mentioned above are implemented and the power from any appropriate source is cut, and read and understand the specific product precautions of all relevant products carefully.
3. Before machinery/equipment is restarted, take measures to prevent unexpected operation and malfunction.

4. Contact SMC beforehand and take special consideration of safety measures if the product is to be used in any of the following conditions.

1. Conditions and environments outside of the given specifications, or use outdoors or in a place exposed to direct sunlight.
2. Installation on equipment in conjunction with atomic energy, railways, air navigation, space, shipping, vehicles, military, medical treatment, combustion and recreation, or equipment in contact with food and beverages, emergency stop circuits, clutch and brake circuits in press applications, safety equipment or other applications unsuitable for the standard specifications described in the product catalogue.
3. An application which could have negative effects on people, property, or animals requiring special safety analysis.
4. Use in an interlock circuit, which requires the provision of double interlock for possible failure by using a mechanical protective function, and periodical checks to confirm proper operation.

Caution

1. The product is provided for use in manufacturing industries.

The product herein described is basically provided for peaceful use in manufacturing industries.

If considering using the product in other industries, consult SMC beforehand and exchange specifications or a contract if necessary. If anything is unclear, contact your nearest sales branch.

Limited warranty and Disclaimer/Compliance Requirements

The product used is subject to the following “Limited warranty and Disclaimer” and “Compliance Requirements”. Read and accept them before using the product.

Limited warranty and Disclaimer

1. The warranty period of the product is 1 year in service or 1.5 years after the product is delivered, whichever is first.²⁾ Also, the product may have specified durability, running distance or replacement parts. Please consult your nearest sales branch.
 2. For any failure or damage reported within the warranty period which is clearly our responsibility, a replacement product or necessary parts will be provided. This limited warranty applies only to our product independently, and not to any other damage incurred due to the failure of the product.
 3. Prior to using SMC products, please read and understand the warranty terms and disclaimers noted in the specified catalogue for the particular products.
- 2) Vacuum pads are excluded from this 1 year warranty.
A vacuum pad is a consumable part, so it is warranted for a year after it is delivered. Also, even within the warranty period, the wear of a product due to the use of the vacuum pad or failure due to the deterioration of rubber material are not covered by the limited warranty.

Compliance Requirements

1. The use of SMC products with production equipment for the manufacture of weapons of mass destruction (WMD) or any other weapon is strictly prohibited.
2. The exports of SMC products or technology from one country to another are governed by the relevant security laws and regulations of the countries involved in the transaction. Prior to the shipment of a SMC product to another country, assure that all local rules governing that export are known and followed.

Caution

SMC products are not intended for use as instruments for legal metrology.

Measurement instruments that SMC manufactures or sells have not been qualified by type approval tests relevant to the metrology (measurement) laws of each country. Therefore, SMC products cannot be used for business or certification ordained by the metrology (measurement) laws of each country.

Safety Instructions

Be sure to read “Handling Precautions for SMC Products” (M-E03-3) before using.

SMC Corporation (Europe)

Austria	+43 (0)2262622800	www.smc.at	office@smc.at
Belgium	+32 (0)33551464	www.smc.be	info@smc.be
Bulgaria	+359 (0)2807670	www.smc.bg	office@smc.bg
Croatia	+385 (0)13707288	www.smc.hr	office@smc.hr
Czech Republic	+420 541424611	www.smc.cz	office@smc.cz
Denmark	+45 70252900	www.smc.dk.com	smc@smcdk.com
Estonia	+372 651 0370	www.smcee.ee	info@smcee.ee
Finland	+358 207513513	www.smc.fi	smc.fi@smc.fi
France	+33 (0)164761000	www.smc-france.fr	supportclient@smc-france.fr
Germany	+49 (0)61034020	www.smc.de	info@smc.de
Greece	+30 210 2717265	www.smchellas.gr	sales@smchellas.gr
Hungary	+36 23513000	www.smc.hu	office@smc.hu
Ireland	+353 (0)14039000	www.smcautomation.ie	sales@smcautomation.ie
Italy	+39 03990691	www.smcitalia.it	mailbox@smcitalia.it
Latvia	+371 67817700	www.smc.lv	info@smc.lv



Lithuania	+370 5 2308118	www.smclt.lt	info@smclt.lt
Netherlands	+31 (0)205318888	www.smc.nl	info@smc.nl
Norway	+47 67129020	www.smc-norge.no	post@smc-norge.no
Poland	+48 222119600	www.smc.pl	office@smc.pl
Portugal	+351 214724500	www.smc.eu	apoioclientept@smc.smces.es
Romania	+40 213205111	www.smcromania.ro	smcromania@smcromania.ro
Russia	+7 (812)3036600	www.smc.eu	sales@smcru.com
Slovakia	+421 (0)413213212	www.smc.sk	office@smc.sk
Slovenia	+386 (0)73885412	www.smc.si	office@smc.si
Spain	+34 945184100	www.smc.eu	post@smc.smces.es
Sweden	+46 (0)86031240	www.smc.nu	smc@smc.nu
Switzerland	+41 (0)523963131	www.smc.ch	info@smc.ch
Turkey	+90 212 489 0 440	www.smcturkey.com.tr	satis@smcturkey.com.tr
UK	+44 (0)845 121 5122	www.smc.uk	sales@smc.uk
South Africa	+27 10 900 1233	www.smcza.co.za	zasales@smcza.co.za