

4.5-Stage Bellows Pad

Pad diameter: $\varnothing 15, \varnothing 20, \varnothing 30, \varnothing 40, \varnothing 46$

- For adsorbing workpieces flowing at high speeds
- Follows various shapes of workpieces.
- Pad material: Silicone rubber (Rubber hardness: A40, A50, A60)

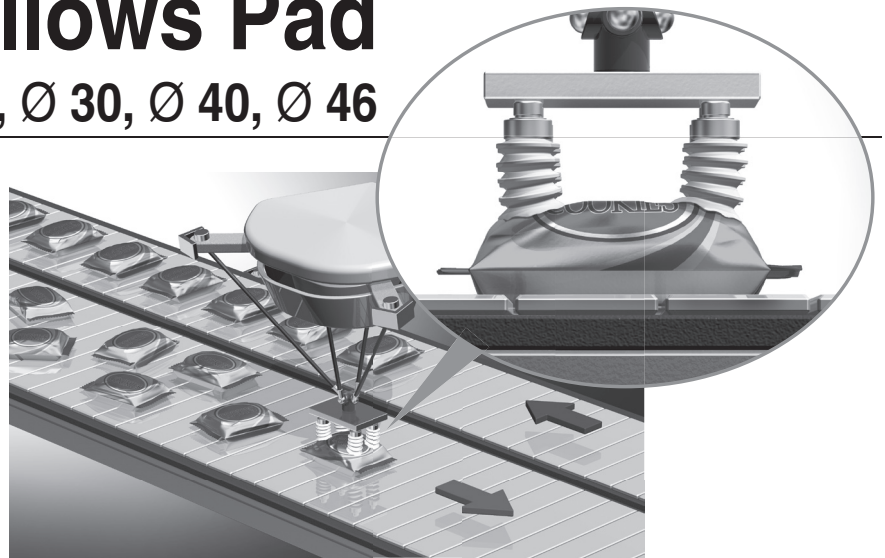

- Short thread type

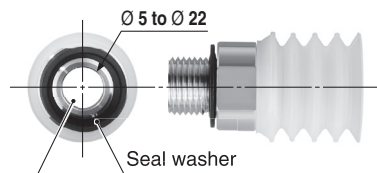
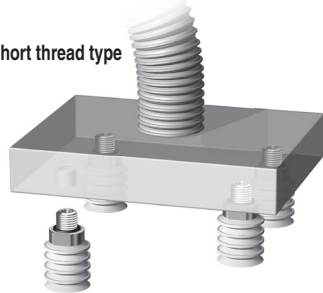

- Large opening size (short thread type): $\varnothing 5 \text{ to } \varnothing 22$
For vacuum blower pumps with high suction flow rates

- One-touch fitting type

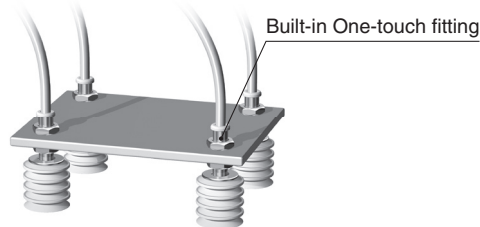

How to Order

Vertical vacuum inlet with adapter

ZP2-T B15 ZJ S-A10-06



Pad diameter

Symbol	Pad diameter
B15	$\varnothing 15$
B20	$\varnothing 20$
B30	$\varnothing 30$
40	$\varnothing 40$
46	$\varnothing 46$

Pad type

Symbol	Type
ZJ	Bellows

- Vacuum inlet

Symbol	Vacuum inlet	Mounting thread size					
		A10	A16	A20	A30	AL12	AL14
—	Short thread	●	●	●	●	—	—
06	One-touch fitting ($\varnothing 6$)	—	—	—	—	●	●

- Pad material

Symbol	Material	Applicable pad diameter					
		$\varnothing 15$	$\varnothing 20$	$\varnothing 30$	$\varnothing 40$	$\varnothing 46$	
N	NBR	—	—	—	●	●	
U	Urethane rubber	—	—	—	●	●	
F	FKM	—	—	—	●	●	
GN	Conductive NBR	—	—	—	●	●	
GS	Conductive silicone rubber (White)	—	—	—	●	●	
S	Silicone rubber (White)	Hardness A40 (Note)	●	●	●	—	—
		Hardness A50	—	—	—	●	●
S6	Silicone rubber High-hardness type (White)	Hardness A60	●	●	●	—	—

Note) Identification of rubber hardness: Painted with pink 1 dot

- Mounting thread size

Type	Symbol	Thread size (Male thread)	$\varnothing 15$	$\varnothing 20$	$\varnothing 30$	$\varnothing 40$	$\varnothing 46$
Short thread	A10	M10 x 1	●	●	—	—	—
	A16	M16 x 1.5	—	—	●	—	—
	A20	M20 x 1.5	—	—	—	●	—
	A30	M30 x 1.5	—	—	—	—	●
One-touch fitting	AL12	M12 x 1	●	●	—	—	—
		M14 x 1	—	—	●	●	●

Replacement Part No. (Short Thread Type)

Product part no.	Pad unit part no.	Adapter part no.
ZP2-TB15ZJS□-A10	ZP2-B15ZJS□	ZP2A-Z31-1P
ZP2-TB20ZJS□-A10	ZP2-B20ZJS□	ZP2A-Z31-2P
ZP2-TB30ZJS□-A16	ZP2-B30ZJS□	ZP2A-Z31-3P
ZP2-T40ZJS-A20	ZP2-40ZJS	ZP2A-Z31-4P
ZP2-T46ZJS-A30	ZP2-46ZJS	ZP2A-Z31-5P

Replacement Part No. (One-touch Fitting Type)

Product part no.	Pad unit part no.	Adapter part no.
ZP2-TB15ZJS□-AL12-06	ZP2-B15ZJS□	ZP2A-Z32-1
ZP2-TB20ZJS□-AL12-06	ZP2-B20ZJS□	ZP2A-Z32-2
ZP2-TB30ZJS□-AL14-06	ZP2-B30ZJS□	ZP2A-Z32-3
ZP2-T40ZJS-AL14-06	ZP2-40ZJS	ZP2A-Z32-4
ZP2-T46ZJS-AL14-06	ZP2-46ZJS	ZP2A-Z32-5

ZP2 Series



12-EU603-UK

ZP2 Series

Dimensions

■ Vacuum inlet: Short thread type

ZP2-TB15ZJS□-A10

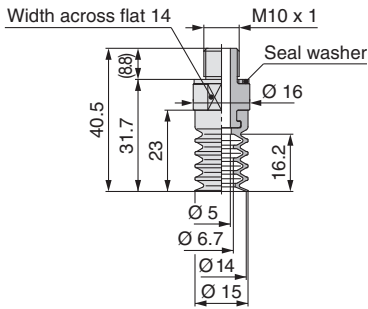

ZP2-TB20ZJS□-A10

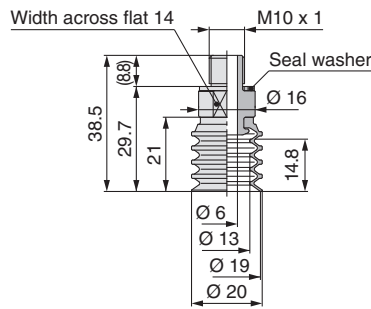

ZP2-TB30ZJS□-A16

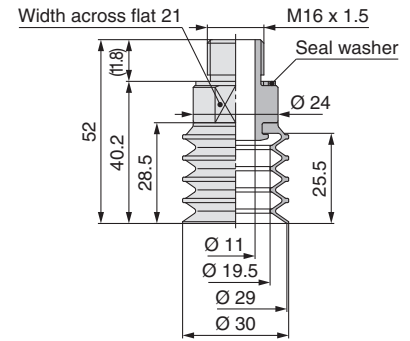

ZP2-T40ZJ□-A20

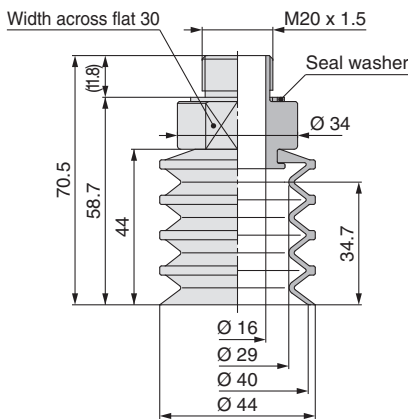

ZP2-T46ZJ□-A30

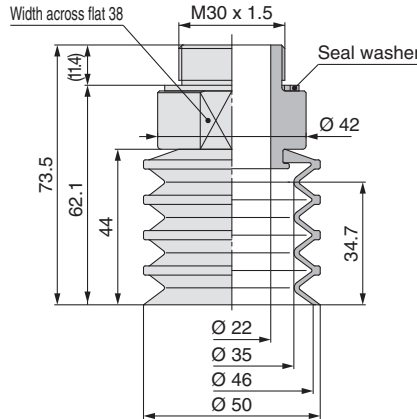

Weight	[g]
ZP2-TB15ZJS□-A10	9.0
ZP2-TB20ZJS□-A10	9.0
ZP2-TB30ZJS□-A16	20.5
ZP2-T40ZN-A20	51.0
ZP2-T40ZJS□-A20	50.0
ZP2-T40ZJU-A20	51.0
ZP2-T40ZJF-A20	60.0
ZP2-T40ZJGN-A20	51.0
ZP2-T40ZJGS-A20	51.0
ZP2-T46ZJN-A30	84.0
ZP2-T46ZJS□-A30	82.0
ZP2-T46ZJU-A30	84.0
ZP2-T46ZJF-A30	95.0
ZP2-T46ZJGN-A30	84.0
ZP2-T46ZJGS-A30	84.0

■ Vacuum inlet: One-touch fitting type

ZP2-TB15ZJS□-AL12-06

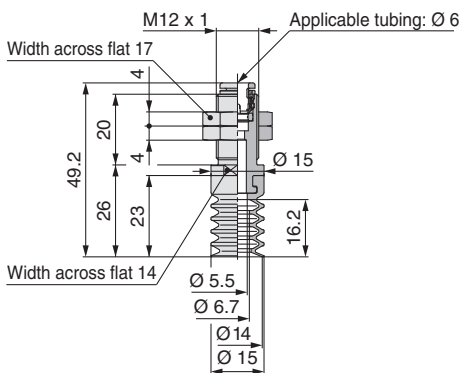

ZP2-TB20ZJS□-AL12-06

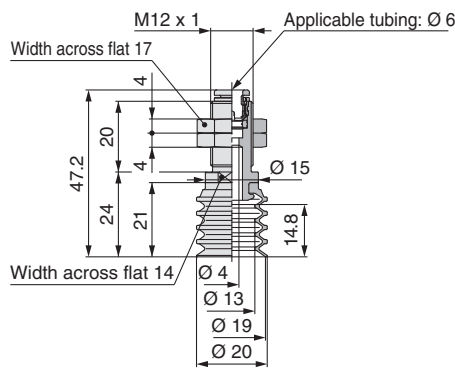

ZP2-TB30ZJS□-AL14-06

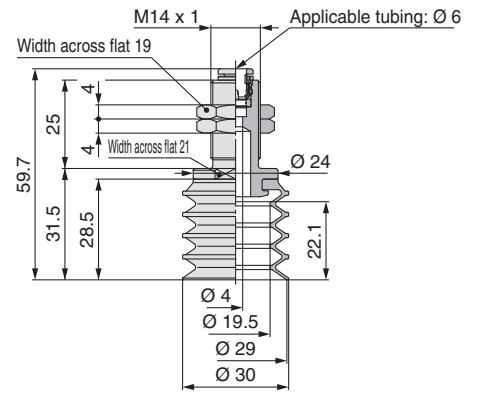

ZP2-T40ZJ□-AL14-06

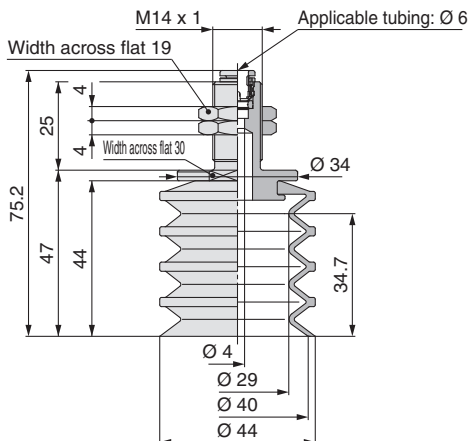

ZP2-T46ZJ□-AL14-06

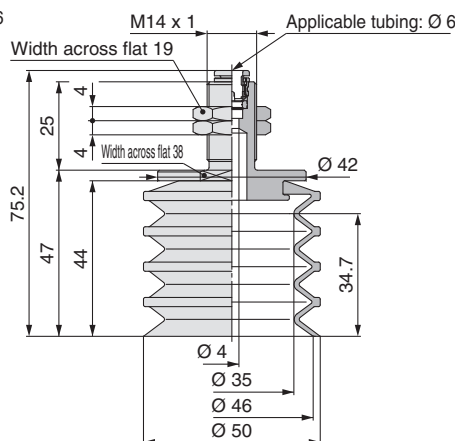

Weight	[g]
ZP2-TB15ZJS□-AL12-06	17.0
ZP2-TB20ZJS□-AL12-06	17.0
ZP2-TB30ZJS□-AL14-06	26.5
ZP2-T40ZJN-AL14-06	46.0
ZP2-T40ZJS□-AL14-06	45.0
ZP2-T40ZJU-AL14-06	46.0
ZP2-T40ZJF-AL14-06	55.0
ZP2-T40ZJGN-AL14-06	46.0
ZP2-T40ZJGS-AL14-06	46.0
ZP2-T46ZJN-AL14-06	56.0
ZP2-T46ZJS□-AL14-06	54.0
ZP2-T46ZJU-AL14-06	56.0
ZP2-T46ZJF-AL14-06	67.0
ZP2-T46ZJGN-AL14-06	56.0
ZP2-T46ZJGS-AL14-06	56.0

How to Order

Pad unit **ZP2-B15ZJ S**

Symbol	Pad diameter
B15	Ø 15
B20	Ø 20
B30	Ø 30
40	Ø 40
46	Ø 46

Pad type	
Symbol	Type
ZJ	Bellows

Pad material

Symbol	Material	Applicable pad diameter					
		Ø 15	Ø 20	Ø 30	Ø 40	Ø 46	
N	NBR	—	—	—	●	●	
U	Urethane rubber	—	—	—	●	●	
F	FKM	—	—	—	●	●	
GN	Conductive NBR	—	—	—	●	●	
GS	Conductive silicone rubber (White)	—	—	—	●	●	
S	Silicone rubber (White)	Hardness A40 (Note)	●	●	●	—	—
		Hardness A50	—	—	—	●	●
S6	Silicone rubber High-hardness type (White)	Hardness A60	●	●	●	—	—

(Note) Identification of rubber hardness: Painted with pink 1 dot

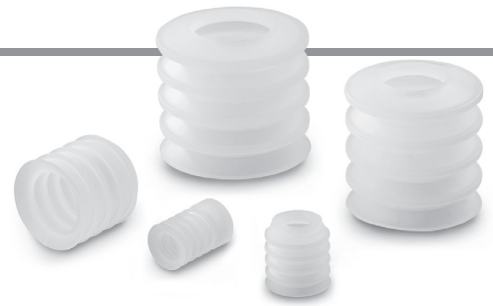

Dimensions: Pad Unit

ZP2-B15ZJS □

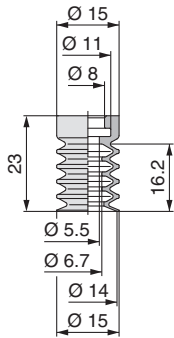

ZP2-B20ZJS □

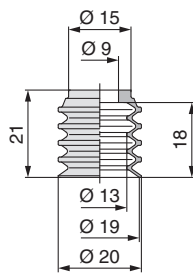

ZP2-B30ZJS □

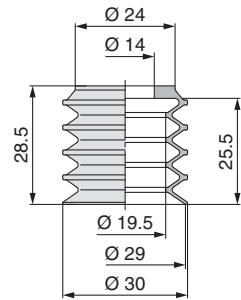

ZP2-40ZJ □

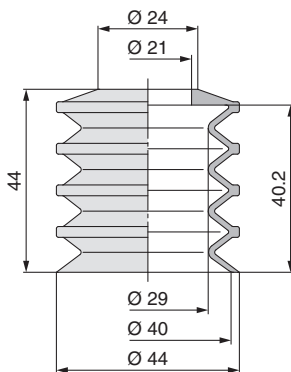

ZP2-46ZJ □

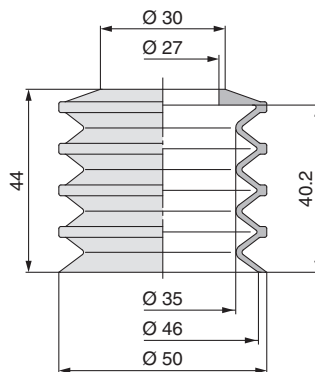

Weight	[g]
ZP2-B15ZJS □	2.0
ZP2-B20ZJS □	2.0
ZP2-B30ZJS □	4.5
ZP2-40ZJN	16.0
ZP2-40ZJS □	15.0
ZP2-40ZJU	16.0
ZP2-40ZJF	25.0
ZP2-40ZJGN	16.0
ZP2-40ZJGS	16.0
ZP2-46ZJN	19.0
ZP2-46ZJS □	17.0
ZP2-46ZJU	19.0
ZP2-46ZJF	30.0
ZP2-46ZJGN	19.0
ZP2-46ZJGS	19.0

Adapter (Mounting) Dimensions

If an adapter will be made by the customer, design the adapter with the dimensions shown below.

Applicable pad **ZP2-B15ZJS** □

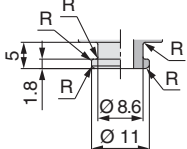

Applicable pad **ZP2-B20ZJS** □

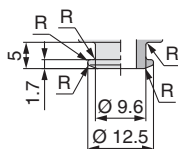

Applicable pad **ZP2-B30ZJS** □

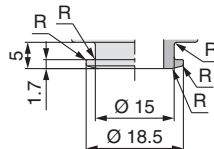

Applicable pad **ZP2-40ZJ** □

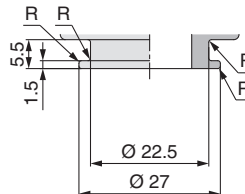

Applicable pad **ZP2-46ZJ** □

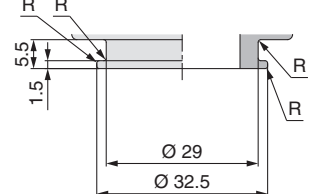

(Note) R part has to be smooth with no corners.

ZP2 Series

Component Parts

■ Short thread type (Pad with adapter)

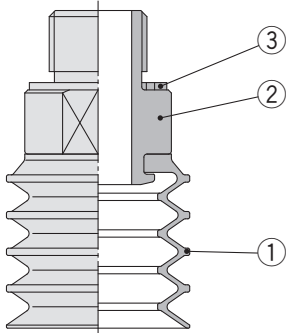

Component Parts

No.	Description	Material (Surface treatment)
1	Pad	Refer to the pad material (Front page)
2	Adapter	Aluminium alloy (Anodised)
3	Seal washer	Structural steel/NBR

■ One-touch fitting type (Pad with adapter)

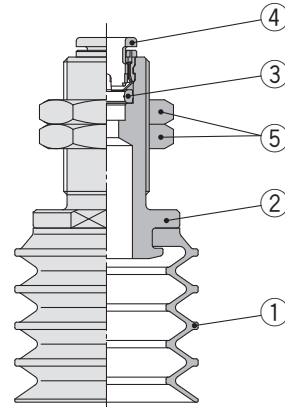

Component Parts

No.	Description	Material (Surface treatment)
1	Pad	Refer to the pad material (Front page)
2	Adapter	Aluminium alloy (Anodised)
3	Seal	NBR
4	Cassette	—
5	Nut	Structural steel (Trivalent chromated)

ZP2 Series

Mounting Adapter Part No.

Short Thread Type

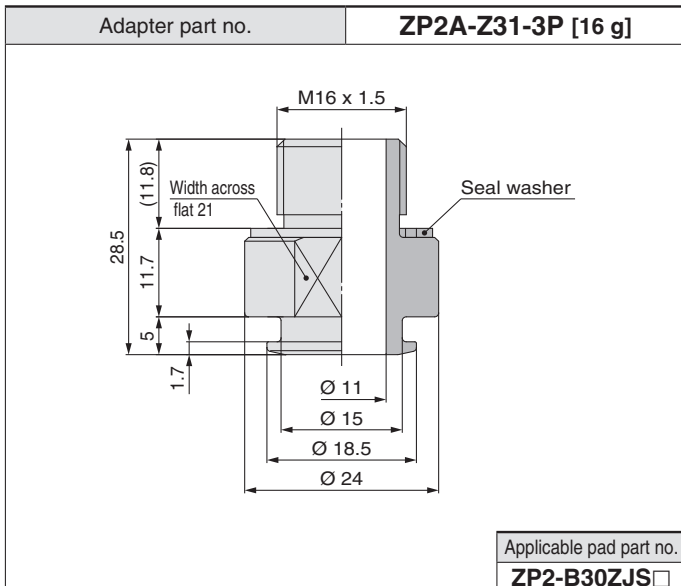
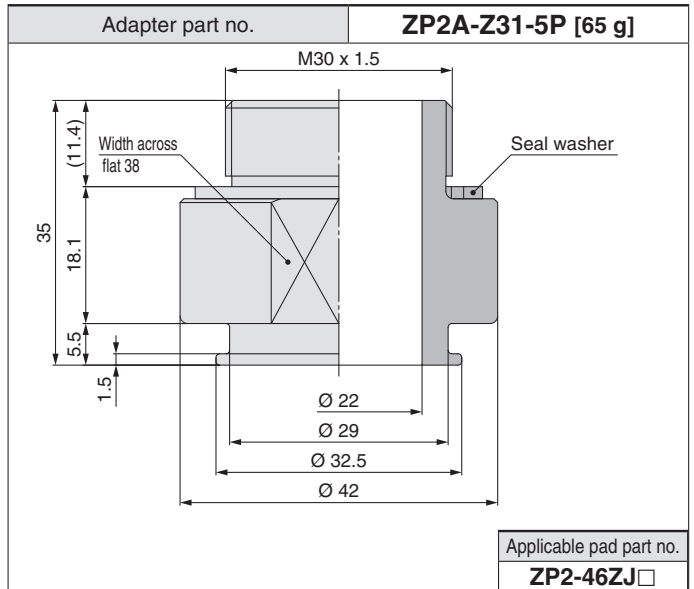
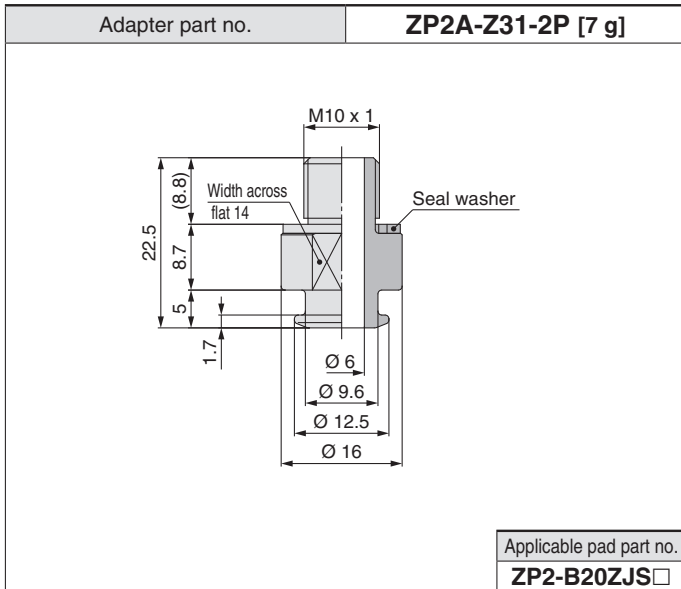
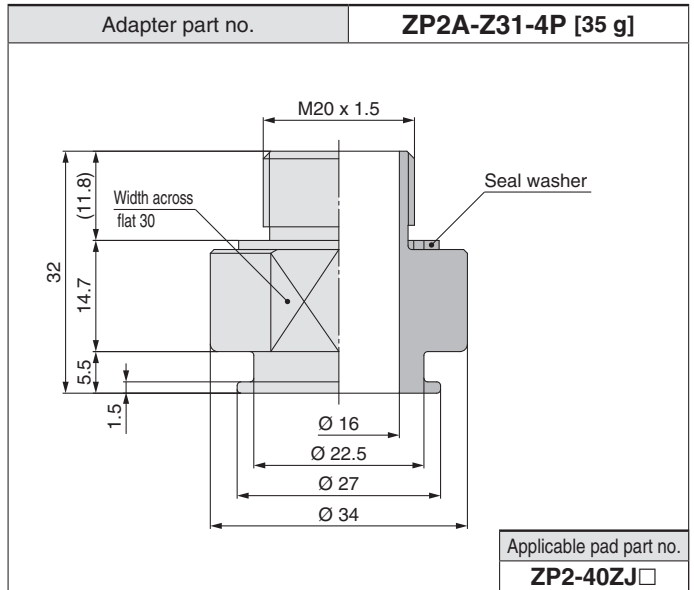
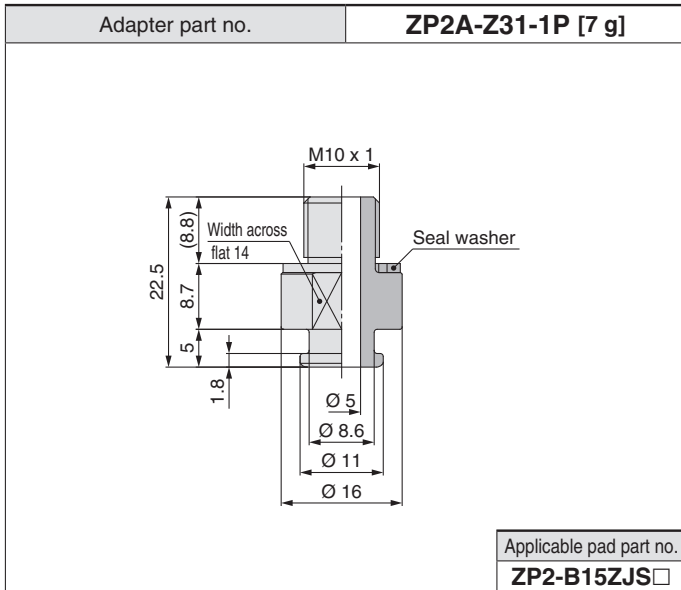

One-touch Fitting Type

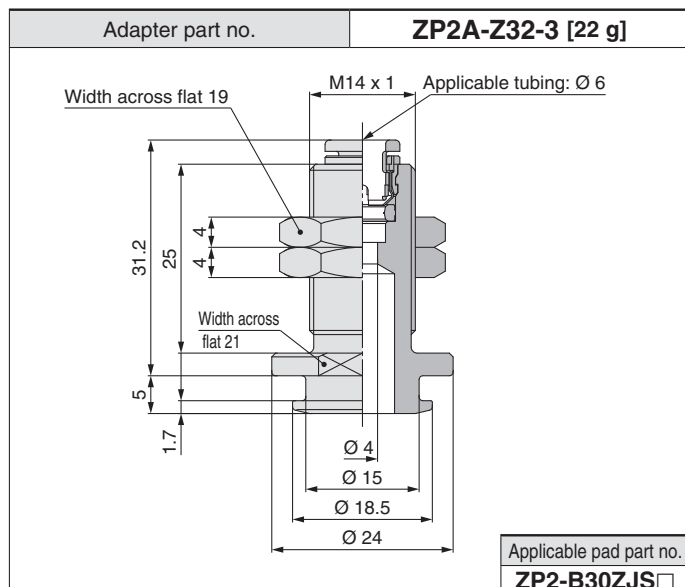
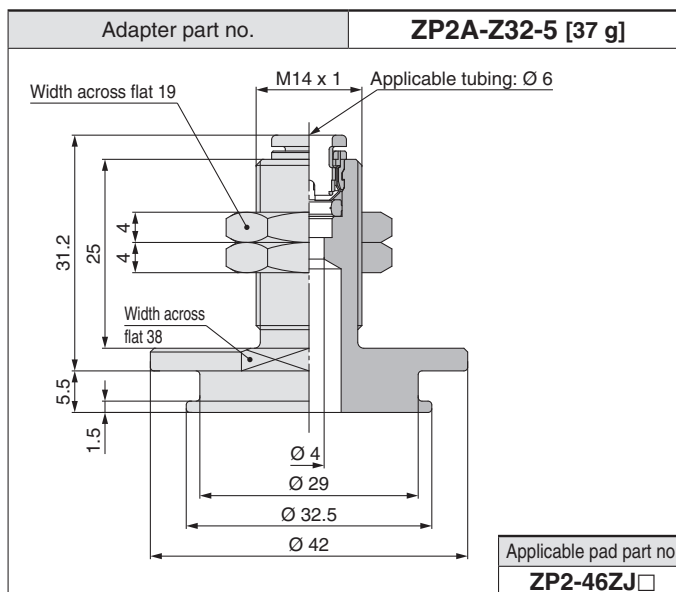
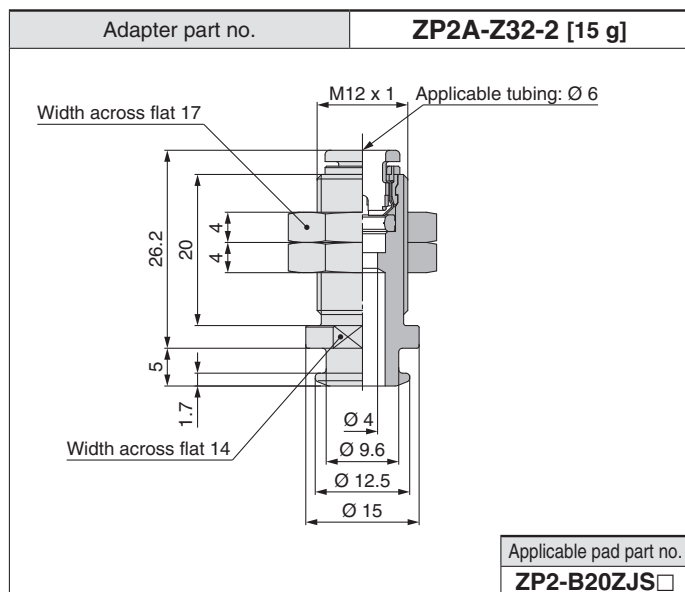
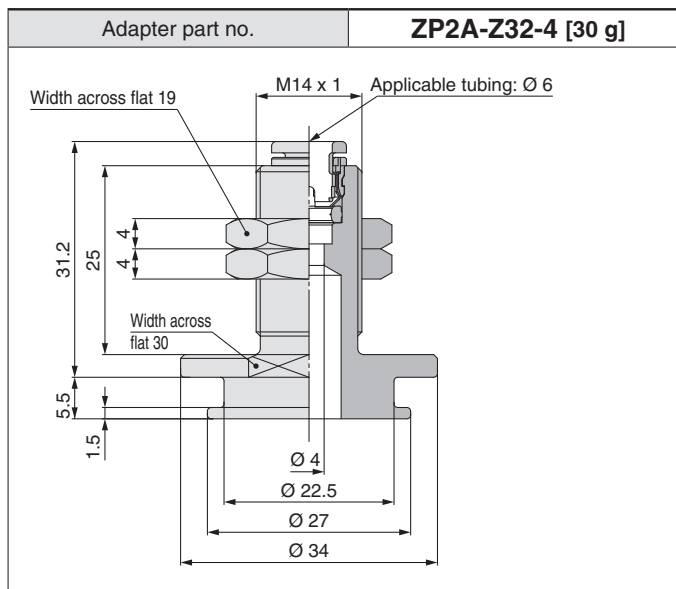
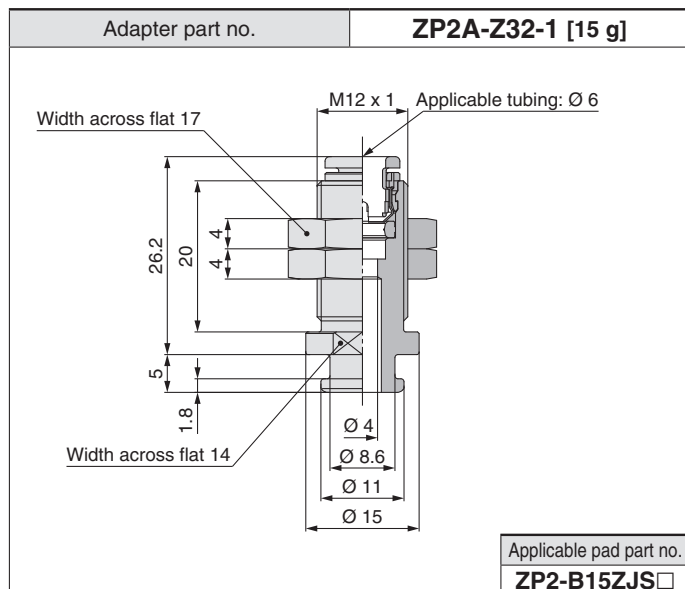

Pad Displacement to Vacuum Pressure (Pad material: Silicone rubber)

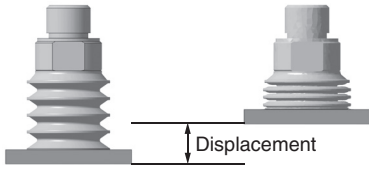

The data shown below are not guaranteed but actual measured (initial value). These values depend on the operating environment, workpiece weight and transfer method, so they cannot be guaranteed by SMC. Thorough research and confirmation are necessary before use.

ZP2-B15ZJS

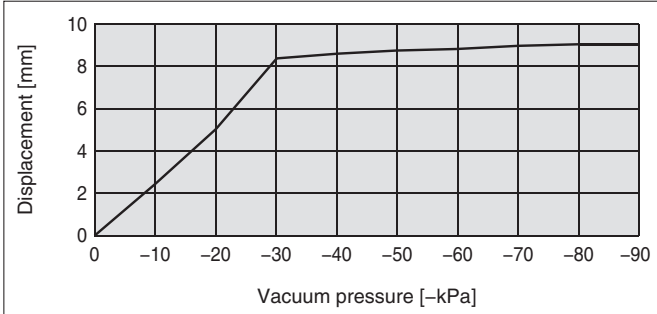

ZP2-B15ZJS6

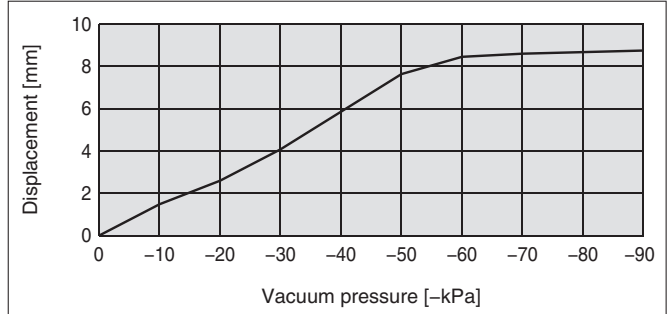

ZP2-B20ZJS

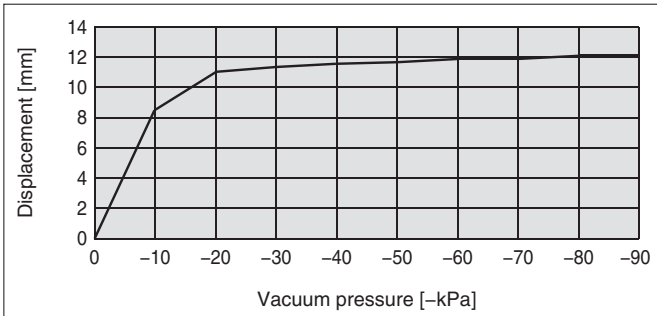

ZP2-B20ZJS6

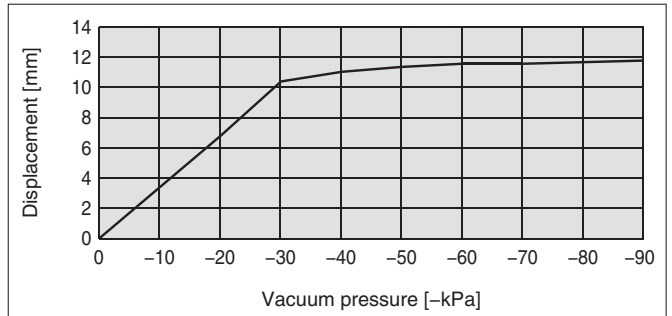

ZP2-B30ZJS

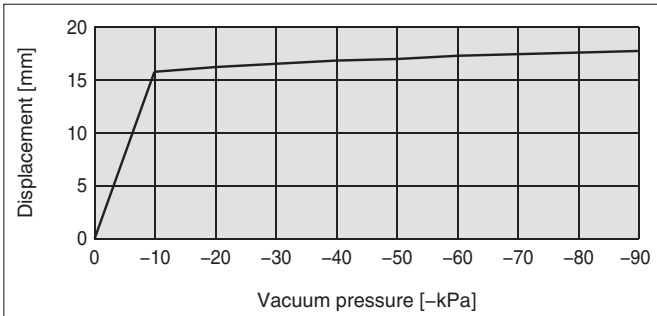

ZP2-B30ZJS6

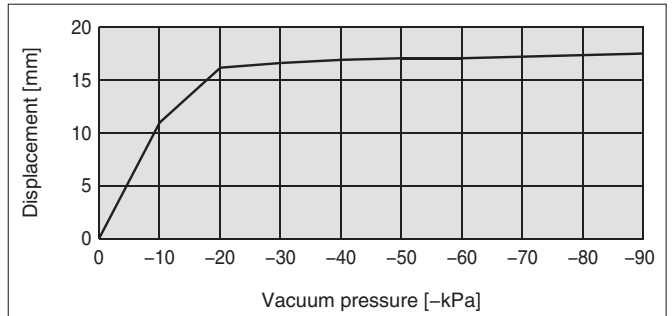

ZP2-40ZJS

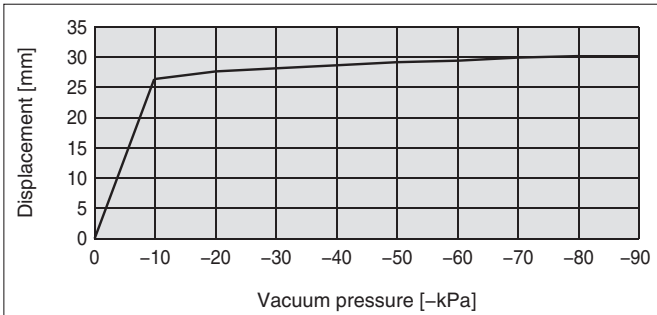

ZP2-46ZJS

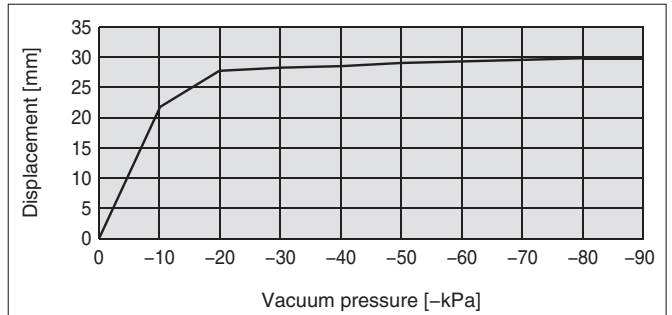

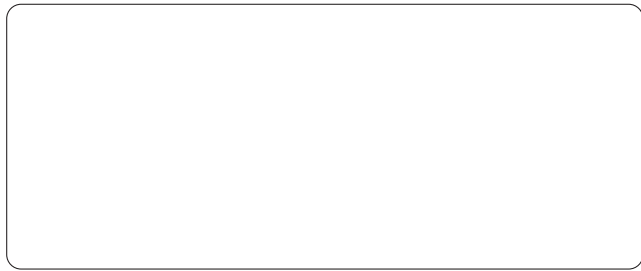

SMC Corporation (Europe)

Austria	☎+43 (0)2262622800	www.smc.at	office@smc.at
Belgium	☎+32 (0)33551464	www.smc.be	info@smc.be
Bulgaria	☎+359 (0)2807670	www.smc.bg	office@smc.bg
Croatia	☎+385 (0)13707288	www.smc.hr	office@smc.hr
Czech Republic	☎+420 541424611	www.smc.cz	office@smc.cz
Denmark	☎+45 70252900	www.smc.dk.com	smc@smcdk.com
Estonia	☎+372 6510370	www.smc.pneumatics.ee	smc@smcpneumatics.ee
Finland	☎+358 207513513	www.smc.fi	smcfi@smc.fi
France	☎+33 (0)164761000	www.smc-france.fr	info@smc-france.fr
Germany	☎+49 (0)61034020	www.smc.de	info@smc.de
Greece	☎+30 210 2717265	www.smchellas.gr	sales@smchellas.gr
Hungary	☎+36 23513000	www.smc.hu	office@smc.hu
Ireland	☎+353 (0)14039000	www.smc.pneumatics.ie	sales@smcpneumatics.ie
Italy	☎+39 0292711	www.smcitalia.it	mailbox@smcitalia.it
Latvia	☎+371 67817700	www.smc.lv	info@smc.lv

Lithuania	☎+370 5 2308118	www.smclt.lt	info@smclt.lt
Netherlands	☎+31 (0)205318888	www.smc.nl	info@smc.nl
Norway	☎+47 67129020	www.smc-norge.no	post@smc-norge.no
Poland	☎+48 222119600	www.smc.pl	office@smc.pl
Portugal	☎+351 226166570	www.smc.eu	postpt@smc.smces.es
Romania	☎+40 213205111	www.smcromania.ro	smcromania@smcromania.ro
Russia	☎+7 8127185445	www.smc-pneumatik.ru	info@smc-pneumatik.ru
Slovakia	☎+421 (0)413213212	www.smc.sk	office@smc.sk
Slovenia	☎+386 (0)73885412	www.smc.si	office@smc.si
Spain	☎+34 945184100	www.smc.eu	post@smc.smces.es
Sweden	☎+46 (0)86031200	www.smc.nu	post@smc.nu
Switzerland	☎+41 (0)523963131	www.smc.ch	info@smc.ch
Turkey	☎+90 212 489 0 440	www.smc.pneumatik.com.tr	info@smcpneumatik.com.tr
UK	☎+44 (0)845 121 5122	www.smc.uk	sales@smc.uk