

Compact Slide

Ø 6, Ø 10, Ø 16, Ø 20, Ø 25



Improved linear guide rigidity

3 times better durability

* Based on SMC's test conditions

New MXH2



Existing MXH



The amount of table **displacement reduced by 48 %**

Displacement due to a force acting in the **pitch** direction

48 % reduction
 0.31 mm
 ↓
 0.16 mm

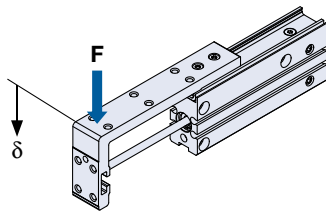

Displacement due to a force acting in the **yaw** direction

63 % reduction
 0.24 mm
 ↓
 0.09 mm

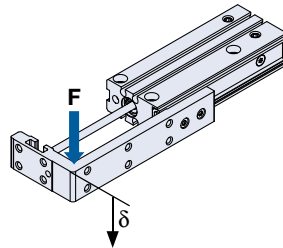

Displacement due to a force acting in the **roll** direction

90 % reduction
 0.06 mm
 ↓
 0.006 mm

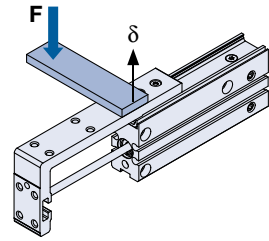

* At Ø 10 and 60 mm stroke, 50 % of the respective allowable load is applied (compared to the existing MXH series) For details, refer to pages 5 to 8.



New Ø 25

- Same width as size Ø 20
- Allowable moment: **Max. 1.4** times greater than that of size Ø 20

Max. standard stroke: 150 mm
 (For Ø 20, Ø 25)



MXH2 Series



CAT.EUS20-276B-UK

High Rigidity Achieved

Increased rigidity by extending the guide length of the linear guide. Significantly reduced table displacement when a moment is applied.

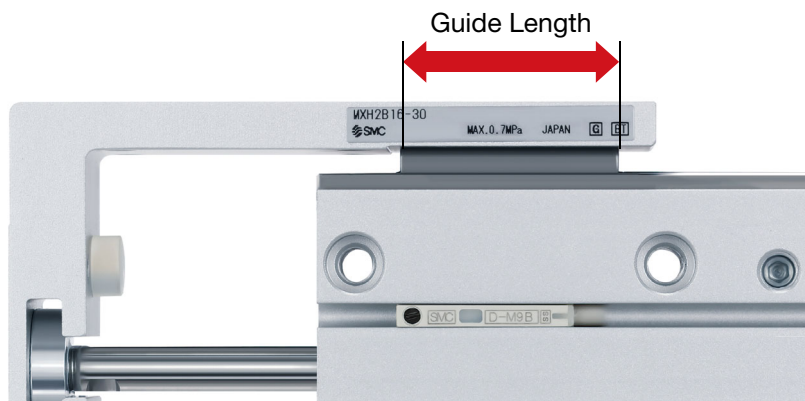

Weight **Max. 6 % reduction**

194 g → **182 g**

(Compared with the existing MXH series Ø 16 and 5 mm stroke)

The allowable moment and traveling parallelism are equivalent to the existing MXH series.

(Ø 6 to Ø 20) **p. 8**

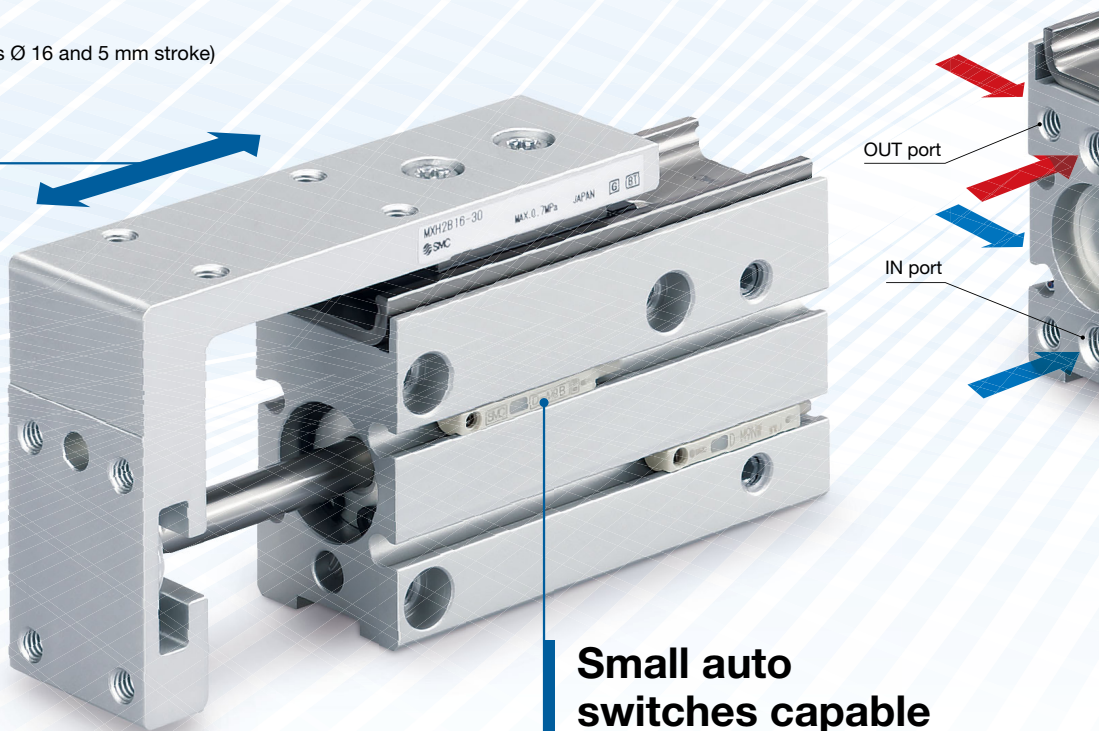

Small auto switches capable
(D-M9□, D-A9□)

Max. standard stroke length has increased. (Max. 150 mm)

(Existing product: Max. 60 mm)

Max. Strokes [mm]

	MXH2	Existing model
Ø 6	60	60
Ø 10	100	
Ø 16	125	
Ø 20	150	
New Ø 25	150	-



Dimensions for mounting and length are equivalent to the existing MXH series.

Dimensions including workpiece mounting dimensions and cylinder mounting dimensions are the same as the existing model.

Piping is possible in 3 directions.

If changing the port location, "Made to Order" model (-XC3□) is available.

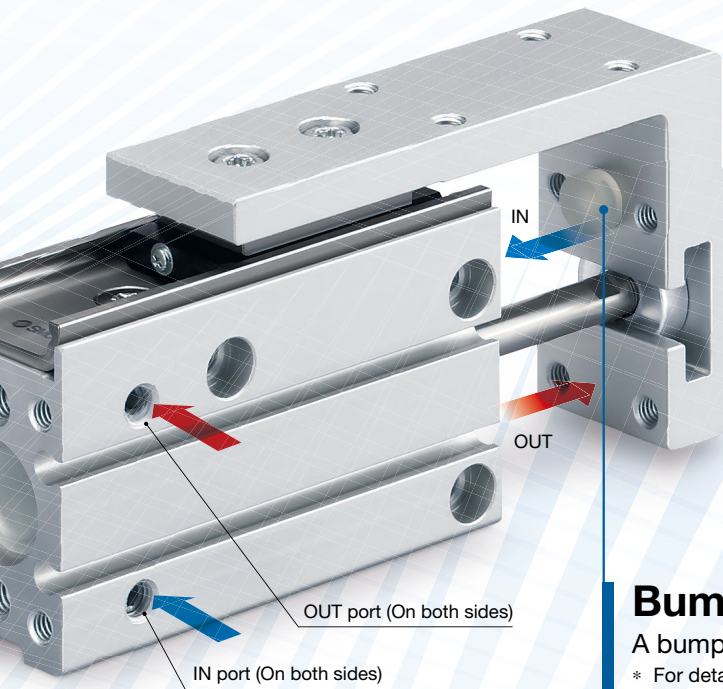

Mounting is possible in 4 directions.

Lateral mounting (Body through-hole)

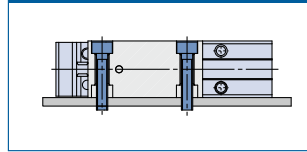

Lateral mounting (Body thread)

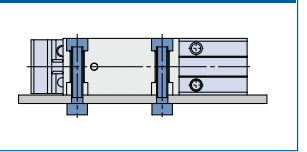

Vertical mounting (Body thread)

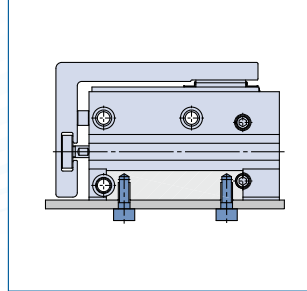

Axial mounting (Body thread)

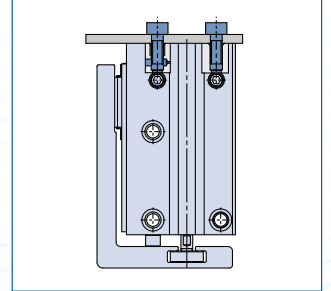

2 mounting options for workpieces are available.

Top mounting

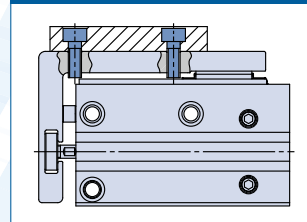

Front mounting

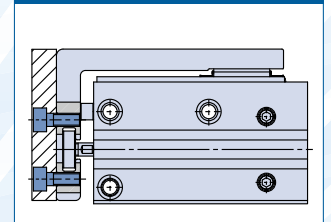

Bumper

A bumper is also installed inside the cylinder.

* For details, refer to page 11, "Construction."

Variations

	Action	Cushion	Bore size [mm]	Stroke [mm]	Made to Order (pp. 23 to 25)
MXH2 	Double acting	Rubber bumper on both ends	6	5 to 60	-XB13 : Low-speed cylinder (5 to 50 mm/s) -XC3□ : Special port location -XC19 : Intermediate stroke (Spacer type) -XC22 : Fluororubber seals -XC79 : Machining tapped hole, drilled hole and pin hole additionally
			10	5 to 100	
			16	5 to 125	
			20	5 to 150	
			New 25	5 to 150	

CONTENTS

Model Selection	p. 3
How to Order	p. 9
Specifications	p.10
Construction	p.11
Dimensions	p. 12
Auto Switch Mounting	p. 21
Simple Specials	p. 23
-XC79 Tapped hole, drilled hole, pinned hole machined additionally	p. 23

Made to Order Common Specifications	p. 24
-XB13 Low-speed cylinder (5 to 50 mm/s)	p. 24
-XC3□ Special port location	p. 24
-XC19 Intermediate stroke (Spacer type)	p. 25
-XC22 Fluororubber seals	p. 25

MXH2 Series Model Selection

⚠ Caution Confirmation of theoretical output is required separately. Refer to “Theoretical Output” on page 10.

Selection Conditions: Follow the tables below in order to determine selection conditions and choose one selection graph.

Mounting orientation	Vertical			Horizontal								
Max. speed [mm/s]	Up to 100	Up to 300	Up to 500	Up to 100			Up to 300			Up to 500		
Load eccentricity L ₁ [mm]	—			50	100	200	50	100	200	50	100	200
Selection graph	1	2	3	4	5	6	7	8	9	10	11	12

* L: Overhang (the distance from the cylinder shaft center to the load center of gravity)
The direction of L can also be a diagonal direction. (Refer to the drawing at right.)

* H: Distance from the cylinder center axis to the mounting surface for the table

H dimension [mm]	5 to 60 mm stroke				75 to 150 mm stroke				
	Ø 6	Ø 10	Ø 16	Ø 20	Ø 25	Ø 10	Ø 16	Ø 20	Ø 25
H dimension [mm]	24.5	30.5	34.5	41.5	48.5	32.5	36.5	45.5	53

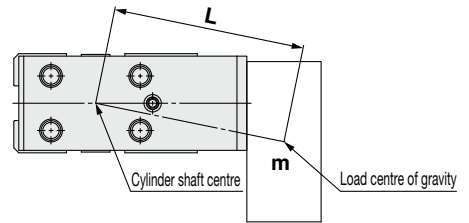

Selection Graph 1 to 3 (Vertical Mounting)

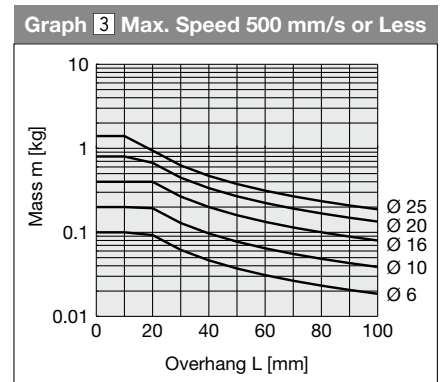
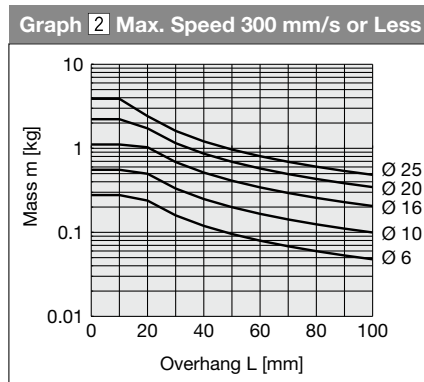
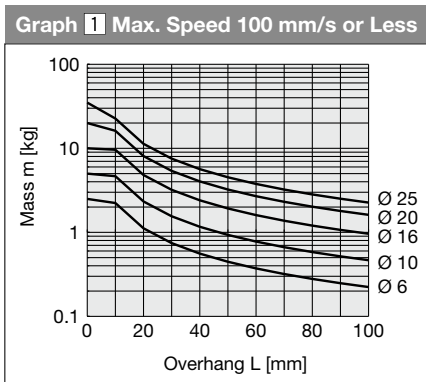

Selection Example (Vertical Mounting)

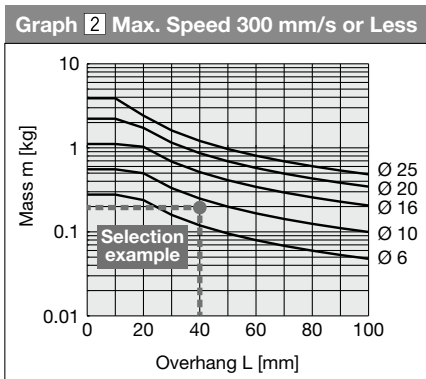

Selection conditions {
 Mounting: Vertical
 Max. speed: 300 mm/s
 Overhang L: 40 mm
 Load mass m: 0.2 kg

* The load mass m should be: mass of workpiece + mass of moving parts (see table below).

Refer to Graph 2 based on vertical mounting and a speed of 300 mm/s.
 From Graph 2, as the intersection of overhang L: 40 mm and load mass m: 0.2 kg is in the area below the Ø 10 line, a Ø 10 is selected.

Mass of Moving Parts

Bore size [mm]	Stroke [mm]												
	5	10	15	20	25	30	40	50	60	75	100	125	150
6	0.02	0.02	0.03	0.03	0.03	0.03	0.03	0.03	0.04	—	—	—	—
10	0.04	0.04	0.05	0.05	0.05	0.05	0.06	0.06	0.06	0.08	0.10	—	—
16	0.08	0.08	0.09	0.09	0.09	0.09	0.10	0.11	0.11	0.14	0.16	0.19	—
20	0.14	0.14	0.15	0.15	0.16	0.16	0.17	0.18	0.19	0.24	0.28	0.31	0.35
25	0.24	0.24	0.26	0.26	0.27	0.27	0.29	0.30	0.32	0.37	0.42	0.47	0.52

Selection Graph 4 to 12 (Horizontal Mounting)

Max. Speed 100 mm/s or Less

Graph 4 Load Eccentricity 50 mm

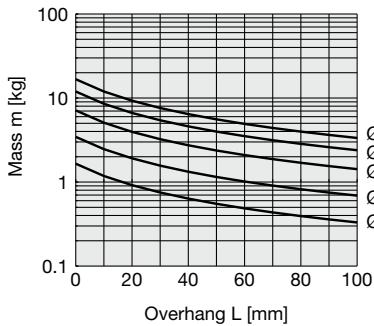

Graph 5 Load Eccentricity 100 mm

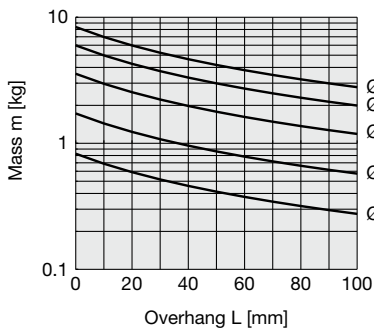

Graph 6 Load Eccentricity 200 mm

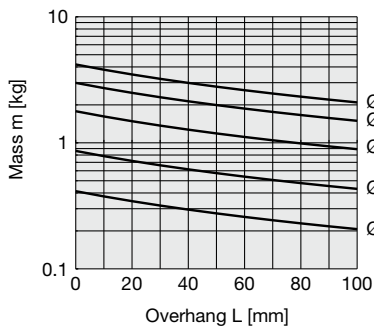

Max. Speed 300 mm/s or Less

Graph 7 Load Eccentricity 50 mm

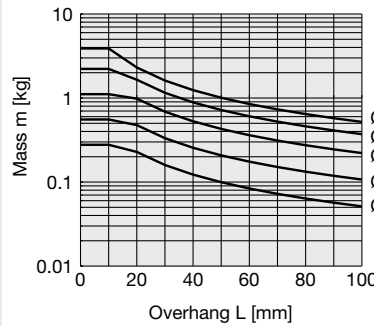

Graph 8 Load Eccentricity 100 mm

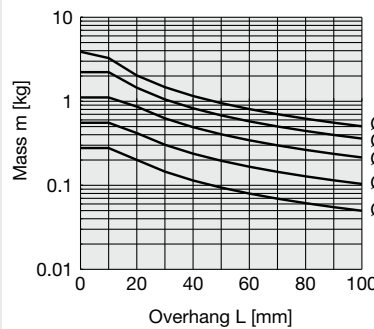

Graph 9 Load Eccentricity 200 mm

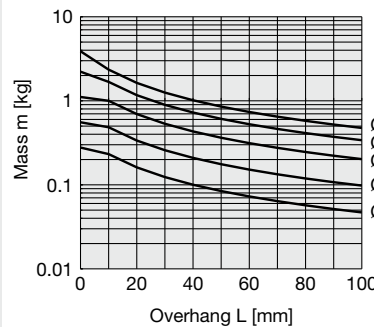

Max. Speed 500 mm/s or Less

Graph 10 Load Eccentricity 50 mm

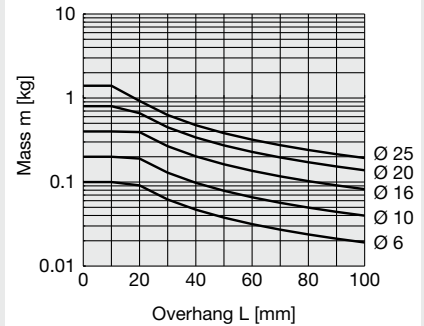

Graph 11 Load Eccentricity 100 mm

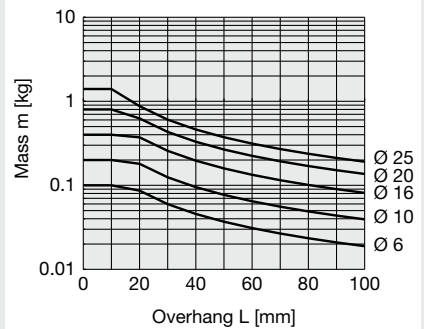

Graph 12 Load Eccentricity 200 mm

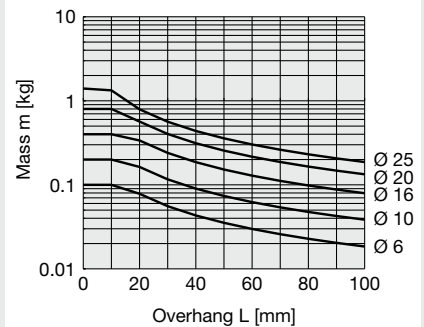

Selection Example (Horizontal Mounting)

Graph 6 Load Eccentricity 200 mm

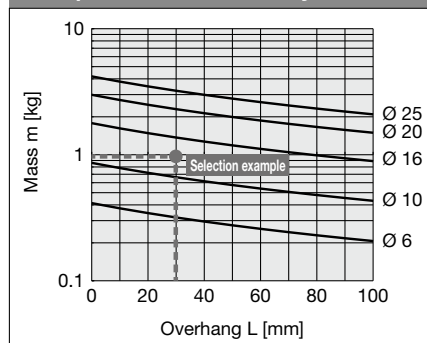

Selection conditions

- Mounting: Horizontal
- Max. speed: 100 mm/s
- Load eccentricity L_1 : 200 mm
- Overhang L : 30 mm
- Load mass m : 1.0 kg

* The load mass m should be: mass of workpiece + mass of moving parts (see table below).

Refer to Graph 6 based on horizontal mounting, a speed of 100 mm/s and load eccentricity L_1 of 200 mm. From Graph 6, as the intersection of overhang L : 30 mm and load mass m : 1.0 kg is in the area below the Ø 16 line, a Ø 16 is selected.

Mass of Moving Parts

Bore size [mm]	Stroke [mm]												
	5	10	15	20	25	30	40	50	60	75	100	125	150
6	0.02	0.02	0.03	0.03	0.03	0.03	0.03	0.03	0.04	—	—	—	—
10	0.04	0.04	0.05	0.05	0.05	0.05	0.06	0.06	0.06	0.08	0.10	—	—
16	0.08	0.08	0.09	0.09	0.09	0.09	0.10	0.11	0.11	0.14	0.16	0.19	—
20	0.14	0.14	0.15	0.15	0.16	0.16	0.17	0.18	0.19	0.24	0.28	0.31	0.35
25	0.24	0.24	0.26	0.26	0.27	0.27	0.29	0.30	0.32	0.37	0.42	0.47	0.52

MXH2 Series

Table Displacement (Reference)

Table displacement due to a force acting in the pitch direction

The amount of Table end displacement when load F is applied directly at the end of stroke in the pitch direction.

Calculate the table end load F using the following formula.
(Refer to the table below for L and α values.)

$$F = \frac{L(1-\alpha)}{L} \times m \times 9.81$$

Table end load [N]
L1: Load eccentricity [mm]
m: Load mass [kg]
L: Refer to the table below.
 α : Refer to the table below.

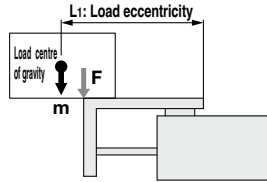

L and α by Bore Size and Stroke

[mm]

Stroke	Ø 6		Ø 10		Ø 16		Ø 20		Ø 25	
	L	α	L	α	L	α	L	α	L	α
5, 10	30		35		39		46		58	
15, 20	40		45		49		56		68	
25, 30	50	14	55	16	59	19	66	19	78	26
40	60		65		69		76		88	
50	70		75		79		86		98	
60	80		85		89		96		108	
75			101	14	107		111		122	
100			126		132	16	136	20	147	27
125					157		161		172	
150							186		197	

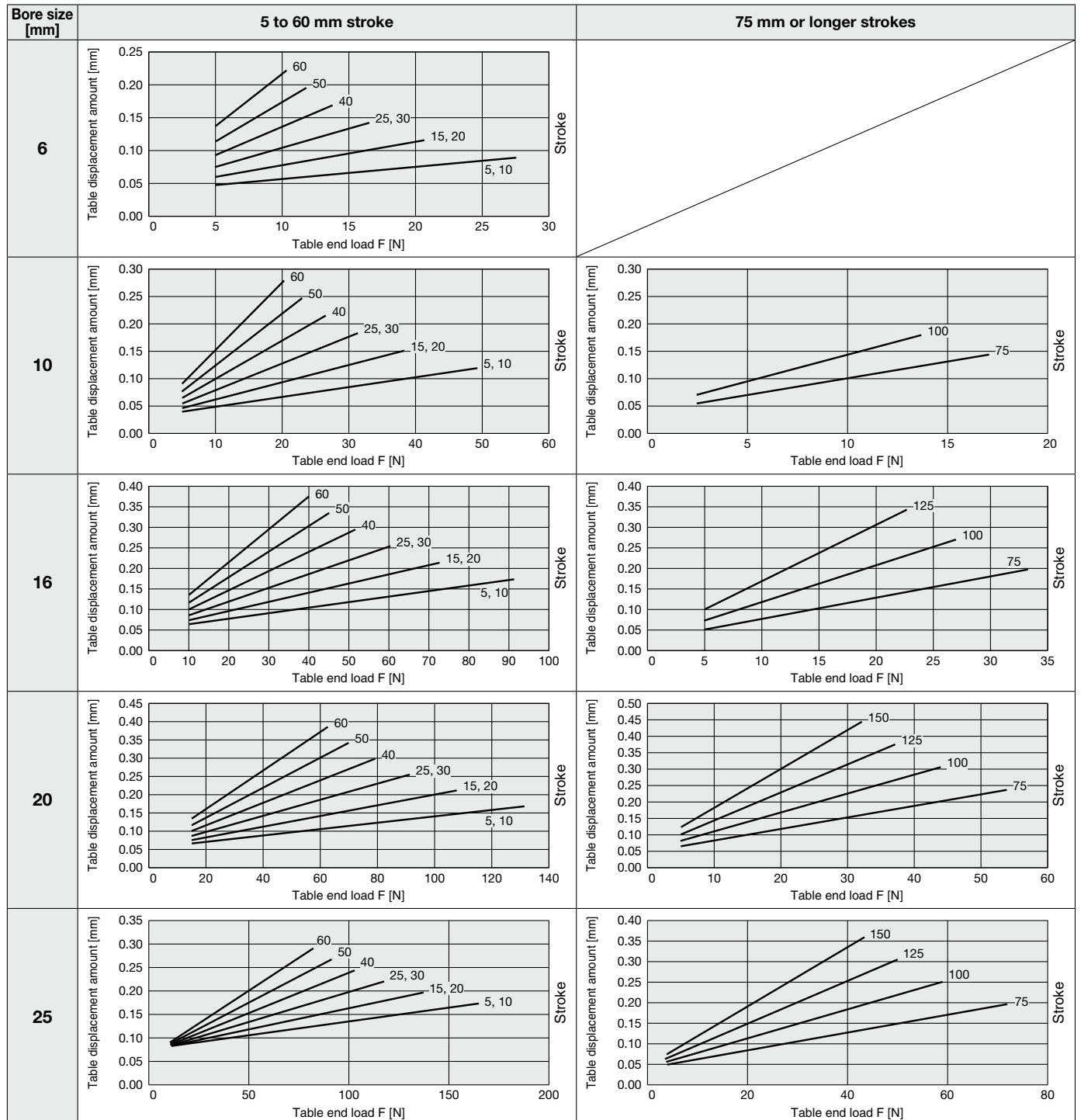

* The displacement values are taken from a downwards pushing force acting directly on the end of the table. This includes any displacement due to the elastic deformation of the guide rolling assembly.

Table displacement due to a force acting in the yaw direction

The amount of Table end displacement when load F is applied directly at the end of stroke in the yaw direction.

Calculate the table end load F using the following formula.
(Refer to the table below for L and α values.)

$$F = \frac{L1 - \alpha}{L} \times m \times 9.81$$

- Table end load [N]
- L1: Load eccentricity [mm]
- m: Load mass [kg]
- L: Refer to the table below.
- α : Refer to the table below.

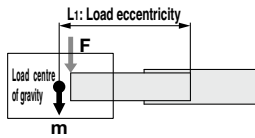

L and α by Bore Size and Stroke

[mm]

Stroke	Ø 6		Ø 10		Ø 16		Ø 20		Ø 25	
	L	α	L	α	L	α	L	α	L	α
5, 10	30		35		39		46		58	
15, 20	40		45		49		56		68	
25, 30	50	14	55	16	59	19	66	19	78	26
40	60		65		69		76		88	
50	70		75		79		86		98	
60	80		85		89		96		108	
75		14	101	16	107	20	111	20	122	27
100			126		132		136		147	
125			157		157		161		172	
150							186		197	

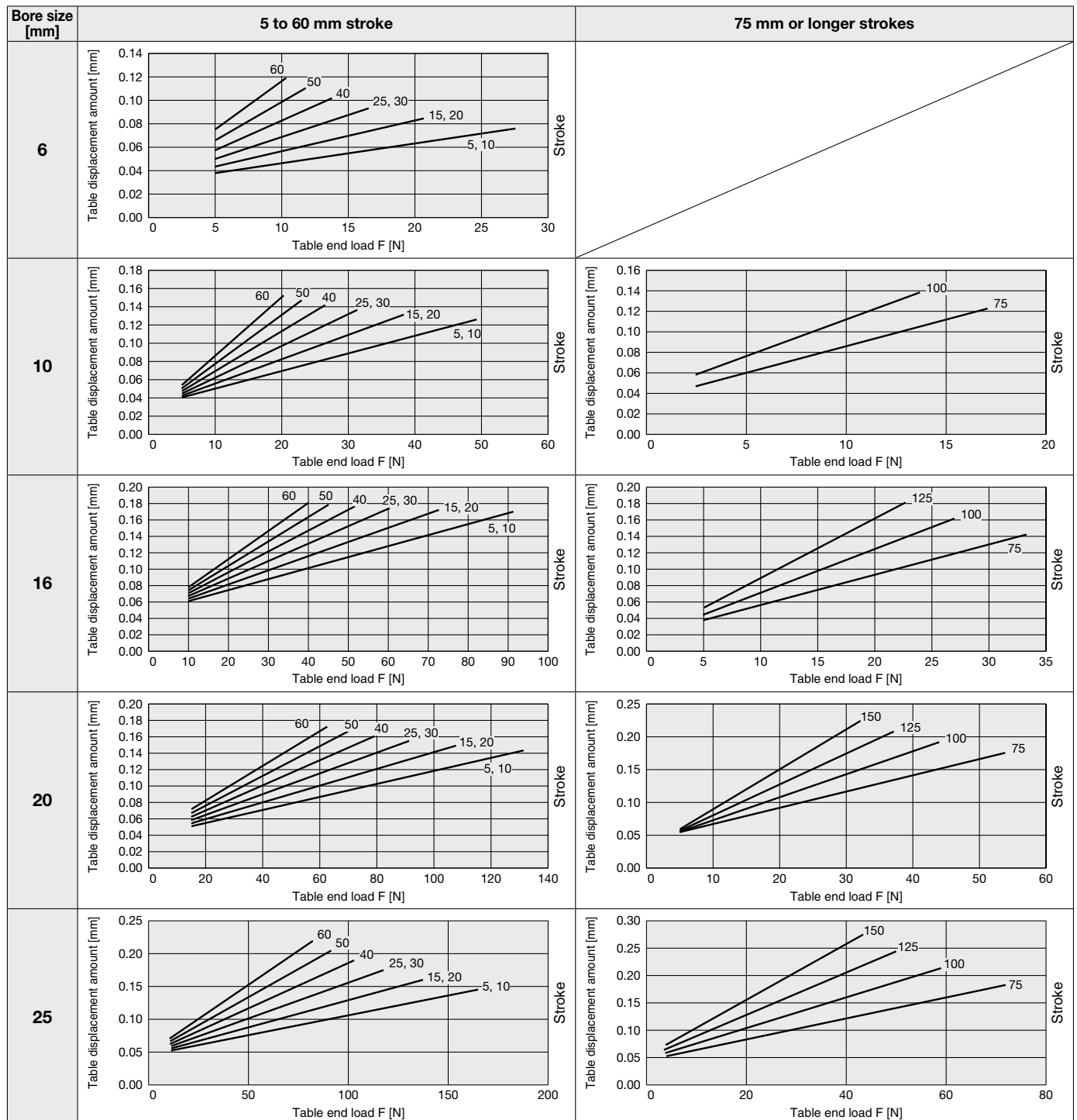
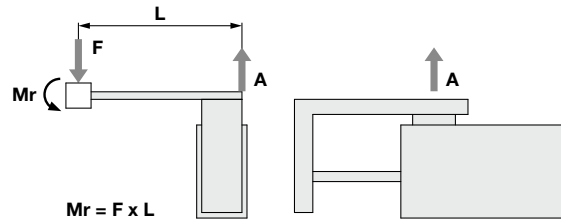

Table Displacement (Reference)

Table Displacement due to a moment force acting in the roll direction

The amount of table displacement (at arrow A) with respect to the roll moment M_r when load F is applied to arrow F at the cylinder's stroke end



Bore size [mm]	5 to 60 mm stroke	75 mm or longer strokes
6		
10		
16		
20		
25		

* The displacement values are taken from a downwards pushing force acting directly on the end of the table. This includes any displacement due to the elastic deformation of the guide rolling assembly.

Traveling Parallelism for a Table

Traveling parallelism	Stroke [mm]					
	5 to 30	40 to 60	75	100	125	150
	0.05 mm or less	0.1 mm or less	0.13 mm or less	0.17 mm or less	0.21 mm or less	0.25 mm or less

* A table deflection caused by load fluctuation, etc. is not included.

Allowable Moment

Bore size [mm]	[N·m]		
	Pitch moment Mp	Yaw moment My	Roll moment Mr
MXH6	0.81	0.81	1.40
MXH10	1.69	1.69	3.19
MXH16	3.49	3.49	6.47
MXH20	5.86	5.86	11.66
MXH25	8.20	8.20	12.72

Design

⚠ Caution

1. Selection of a bore size cannot be made only with above allowable moment. Select a bore size in accordance with "Model Selection" on pages 3 and 4.
2. If the output of the compact slide is applied directly to the table, make sure it is applied along the rod axial line.

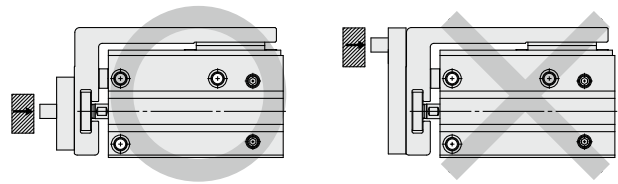

Backlash in the Stroke Direction

⚠ Caution

1. Since the connection between the piston rod and table is a floating mechanism, the table has backlash in the stroke direction.

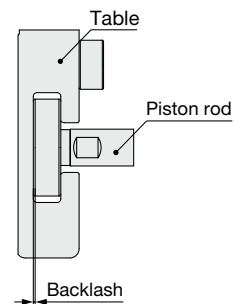

Connecting part of piston rod and table

Compact Slide

MXH2 Series

∅ 6, ∅ 10, ∅ 16, ∅ 20, ∅ 25



How to Order

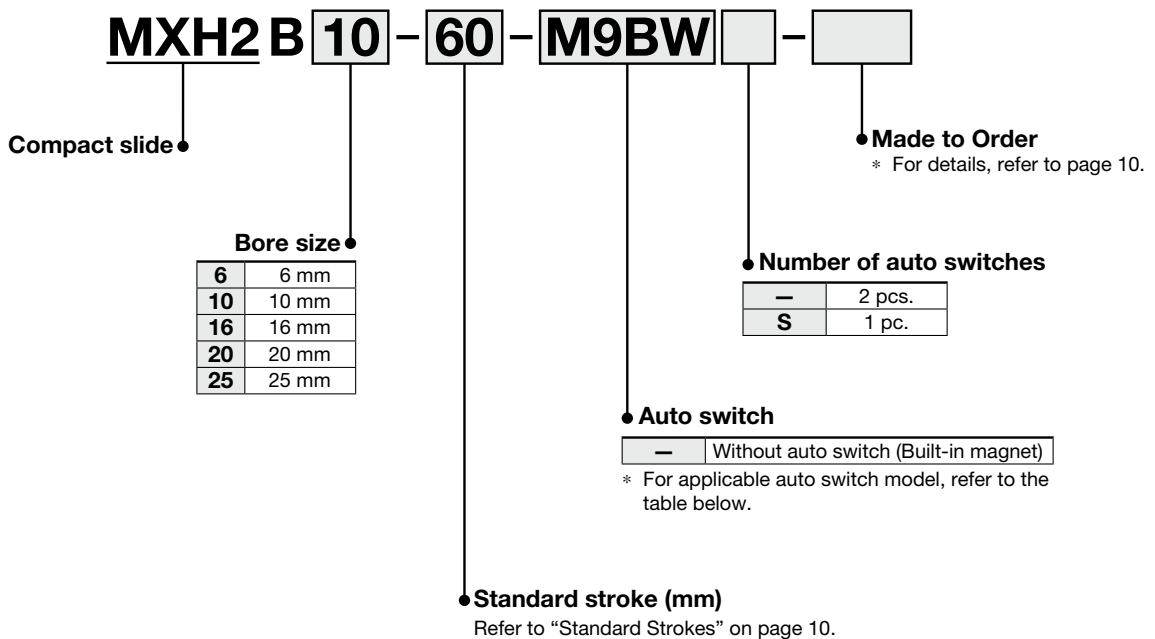

Applicable Auto Switches / Refer to the Web Catalogue for further information on auto switches.

Type	Special function	Electrical entry	Indicator light	Wiring (Output)	Load voltage		Auto switch model		Lead wire length (m)				Pre-wired connector	Applicable load			
					DC	AC	Perpendicular	In-line	0.5 (-)	1 (M)	3 (L)	5 (Z)					
Solid state auto switch	-	Grommet	Yes	3-wire (NPN)	24 V	5 V, 12 V	-	M9NV	M9N	●	●	●	○	○	IC circuit	Relay, PLC	
				3-wire (PNP)				M9PV	M9P	●	●	●	○	○			
				2-wire				M9BV	M9B	●	●	●	○	○			
	Diagnostic indication (2-colour indicator)			3-wire (NPN)	24 V	5 V, 12 V	-	M9NWV	M9NW	●	●	●	○	○	○		IC circuit
				3-wire (PNP)				M9PWV	M9PW	●	●	●	○	○			
				2-wire				M9BWV	M9BW	●	●	●	○	○			
	Water resistant (2-colour indicator)			3-wire (NPN)	24 V	5 V, 12 V	-	M9NAV*1	M9NA*1	○	○	●	○	○	○		IC circuit
				3-wire (PNP)				M9PAV*1	M9PA*1	○	○	●	○	○			
				2-wire				M9BAV*1	M9BA*1	○	○	●	○	○			
Reed auto switch	-	Grommet	Yes	3-wire (NPN equivalent)	-	5 V	-	A96V	A96	●	-	●	-	-	IC circuit	-	
				2-wire	24 V	12 V	100 V	A93V*2	A93	●	●	●	●	-	-	Relay, PLC	
			No			100 V or less		A90V	A90	●	-	●	-	-	IC circuit	PLC	

*1 Water-resistant type auto switches can be mounted on the above models, but SMC cannot guarantee water resistance.

*2 The 1 m lead wire is only applicable to the D-A93.

* Lead wire length symbols: 0.5 m - (Example) M9NW
 1 m M (Example) M9NWM
 3 m L (Example) M9NWL
 5 m Z (Example) M9NWZ

* Solid state auto switches marked with a "○" are produced upon receipt of order.

* Refer to page 22 for applicable auto switches other than listed above.

* For details on auto switches with pre-wired connectors, refer to the Web Catalogue.

* Auto switches are shipped together with the product but do not come assembled.



Symbol

Rubber bumper

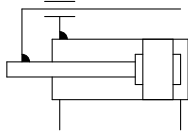

Made to Order

(For details, refer to pages 23 to 25.)

Symbol	Specifications
-XC79	Tapped hole, drilled hole, pinned hole machined additionally
-XB13	Low-speed cylinder (5 to 50 mm/s)
-XC3□	Special port location
-XC19	Intermediate stroke (Spacer type)
-XC22	Fluororubber seals

Specifications

Bore size [mm]		6	10	16	20	25
Fluid		Air				
Action		Double acting				
Piping port size		M5 x 0.8				
Minimum operating pressure		0.2 MPa	0.1 MPa		0.08 MPa	0.06 MPa
Maximum operating pressure		0.7 MPa				
Proof pressure		1.05 MPa				
Ambient and fluid temperature		Without auto switch: -10 to 70 °C (No freezing) With auto switch: -10 to 60 °C (No freezing)				
Piston speed		50 to 500 mm/s				
Allowable kinetic energy [J]		0.0125	0.025	0.05	0.1	0.175
Lubrication	Cylinder unit	Non-lube				
	Guide unit	Lubrication recommended*1				
Cushion		Rubber bumper on both ends				
Stroke length tolerance		+1.0 0				

*1 Depending on the operating conditions and environment, the performance of the linear guide can be significantly prolonged by regularly greasing the linear guide rails.

A grease pack is not included. Order it separately.

Grease pack part no.: GR-S-010 (10 g)

Standard Strokes

Bore size [mm]	Standard stroke [mm]
6	5, 10, 15, 20, 25, 30, 40, 50, 60
10	5, 10, 15, 20, 25, 30, 40, 50, 60, 75, 100
16	5, 10, 15, 20, 25, 30, 40, 50, 60, 75, 100, 125
20	5, 10, 15, 20, 25, 30, 40, 50, 60, 75, 100, 125, 150
25	5, 10, 15, 20, 25, 30, 40, 50, 60, 75, 100, 125, 150

* Intermediate strokes are available with "Made to Order" model (-XC19). (For details, refer to page 25.)

Theoretical Output

Bore size [mm]	Rod size [mm]	Operating direction	Piston area [mm ²]	Operating pressure [MPa]		
				0.3	0.5	0.7
6	3	OUT	28	8	14	19
		IN	21	6	10	14
10	4	OUT	78	23	39	55
		IN	66	19	33	46
16	6	OUT	201	60	101	141
		IN	172	51	86	121
20	8	OUT	314	94	157	220
		IN	264	79	132	185
25	10	OUT	491	147	245	344
		IN	412	124	206	289

Weight

Bore size [mm]	Stroke [mm]												
	5 st	10 st	15 st	20 st	25 st	30 st	40 st	50 st	60 st	75 st	100 st	125 st	150 st
6	61	68	75	82	89	96	110	124	137	—	—	—	—
10	103	113	124	134	144	154	174	195	215	259	312	—	—
16	182	196	210	224	238	251	279	306	333	406	481	554	—
20	347	370	392	415	438	460	505	550	596	706	826	948	1069
25	470	473	521	524	572	575	624	675	726	834	968	1102	1237

Refer to pages 21 and 22 for cylinders with auto switches.

- Minimum Stroke for Auto Switch Mounting
- Auto Switch Proper Mounting Position (Detection at Stroke End) and Mounting Height
- Operating Range
- Auto Switch Mounting

MXH2 Series

Construction

Ø 6 to Ø 16

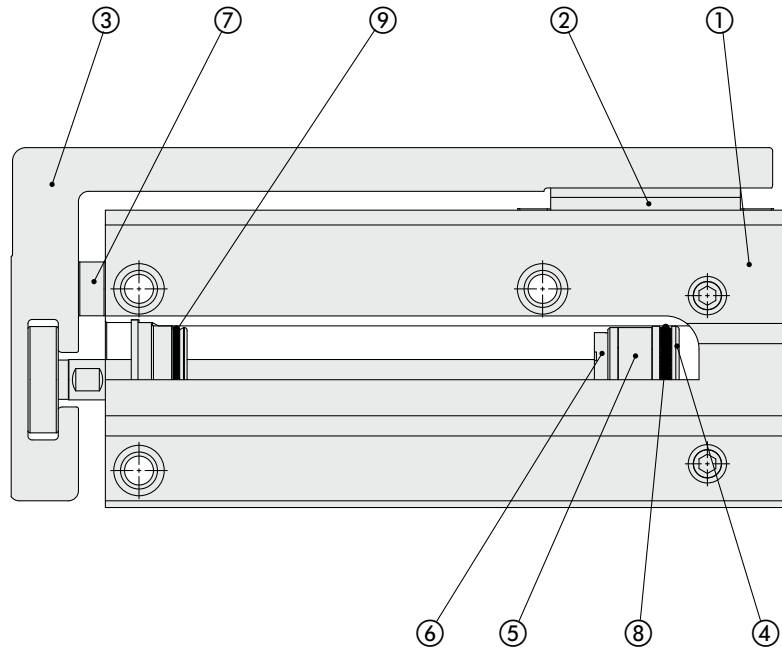

Ø 20, Ø 25

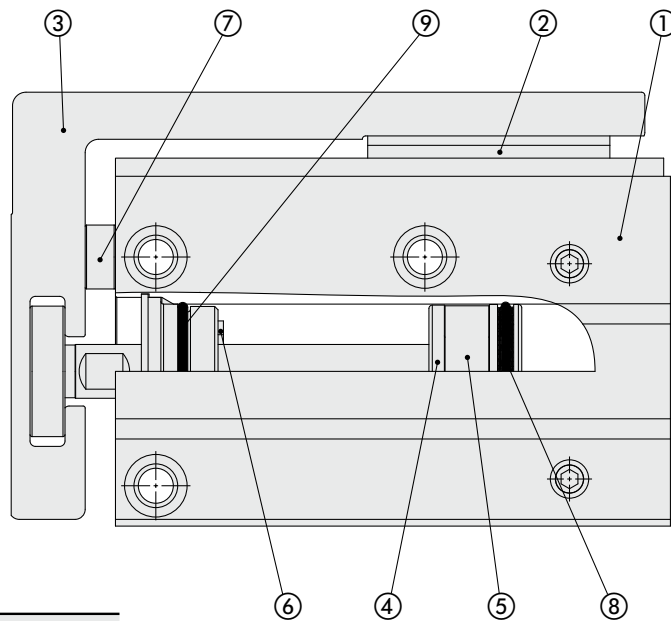

Component Parts

No.	Description
1	Cylinder tube
2	Guide
3	Table
4	Piston
5	Magnet
6	Bumper
7	Bumper
8	Piston seal
9	Gasket

Dimensions: $\varnothing 6$

5 to 60 mm stroke

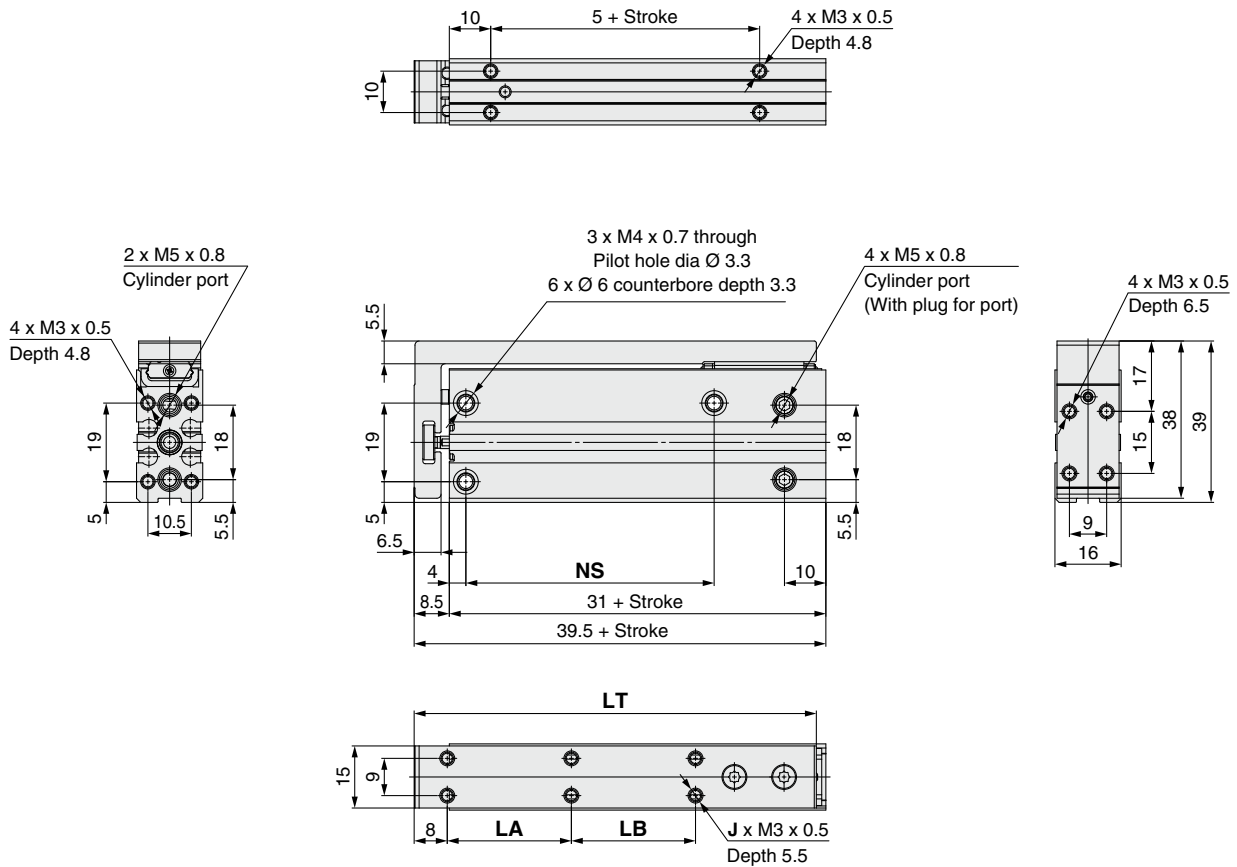

* Refer to the operation manual for compact slide mounting, workpiece mounting, and changing port locations.

Stroke	J	LA	LB	LT	NS
5	4	10	—	42	14
10	4	10	—	47	14
15	4	20	—	52	24
20	4	20	—	57	24
25	4	30	—	62	30
30	4	30	—	67	30
40	6	20	20	77	45
50	6	25	25	87	55
60	6	30	30	97	60

MXH2 Series

Dimensions: $\varnothing 10$

5 to 60 mm stroke

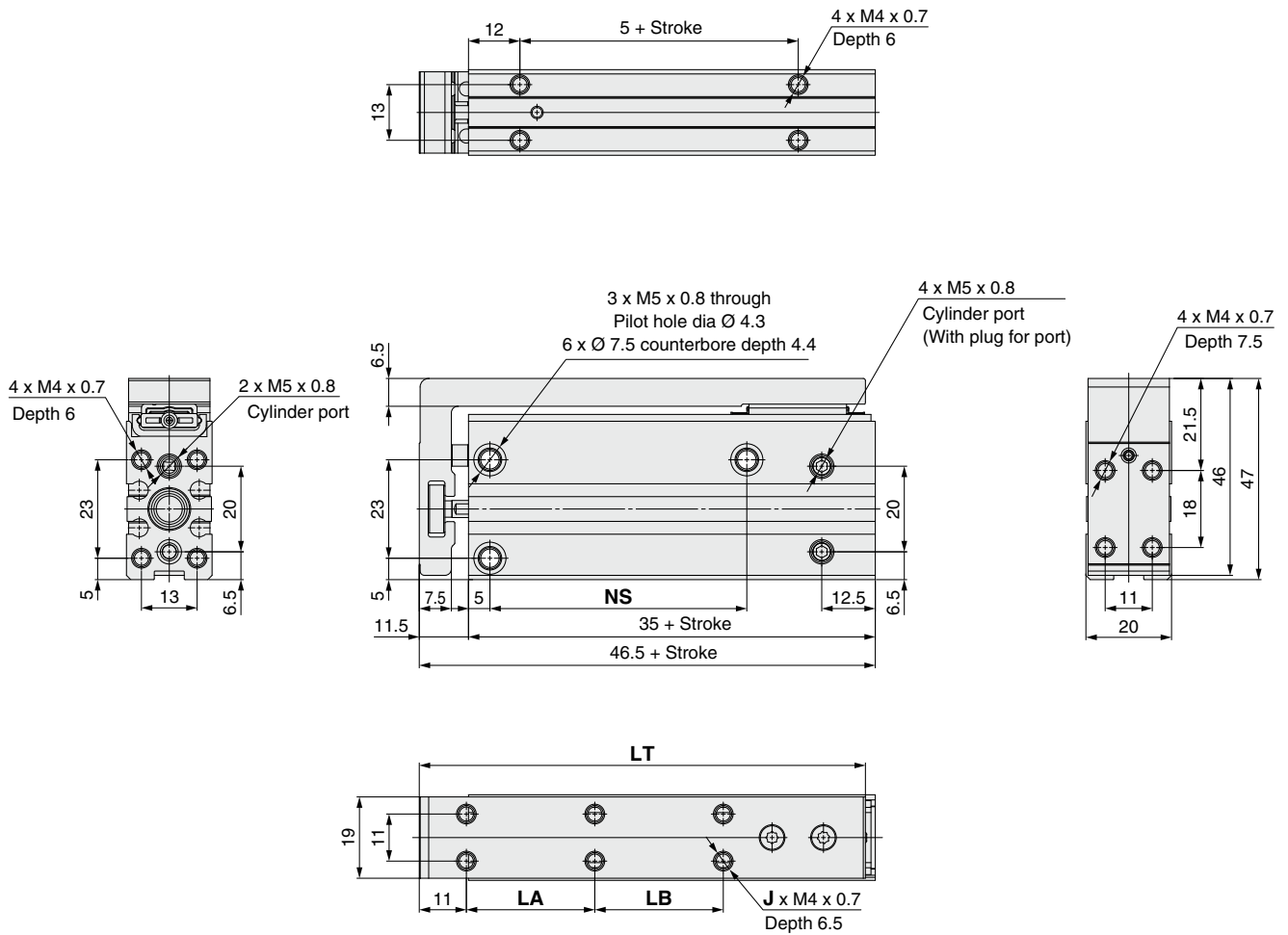

* Refer to the operation manual for compact slide mounting, workpiece mounting, and changing port locations.

Stroke	J	LA	LB	LT	NS
5	4	10	—	49	14
10	4	10	—	54	14
15	4	20	—	59	24
20	4	20	—	64	24
25	4	30	—	69	30
30	4	30	—	74	30
40	6	20	20	84	45
50	6	25	25	94	55
60	6	30	30	104	60

Dimensions: $\varnothing 10$

75 and 100 mm stroke

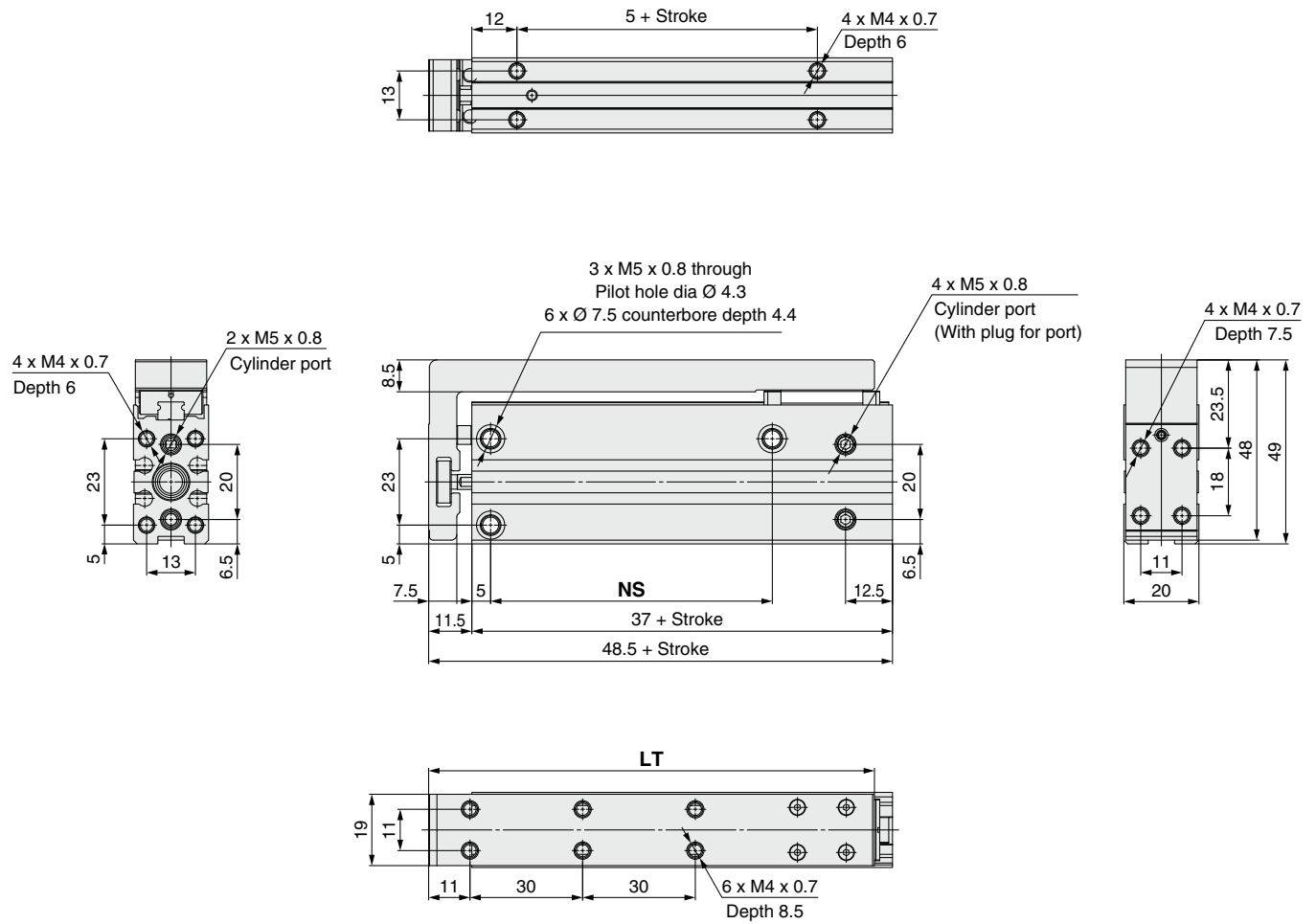

* Refer to the operation manual for compact slide mounting, workpiece mounting, and changing port locations.

	[mm]	
Stroke	LT	NS
75	119	75
100	144	100

MXH2 Series

Dimensions: $\varnothing 16$

5 to 60 mm stroke

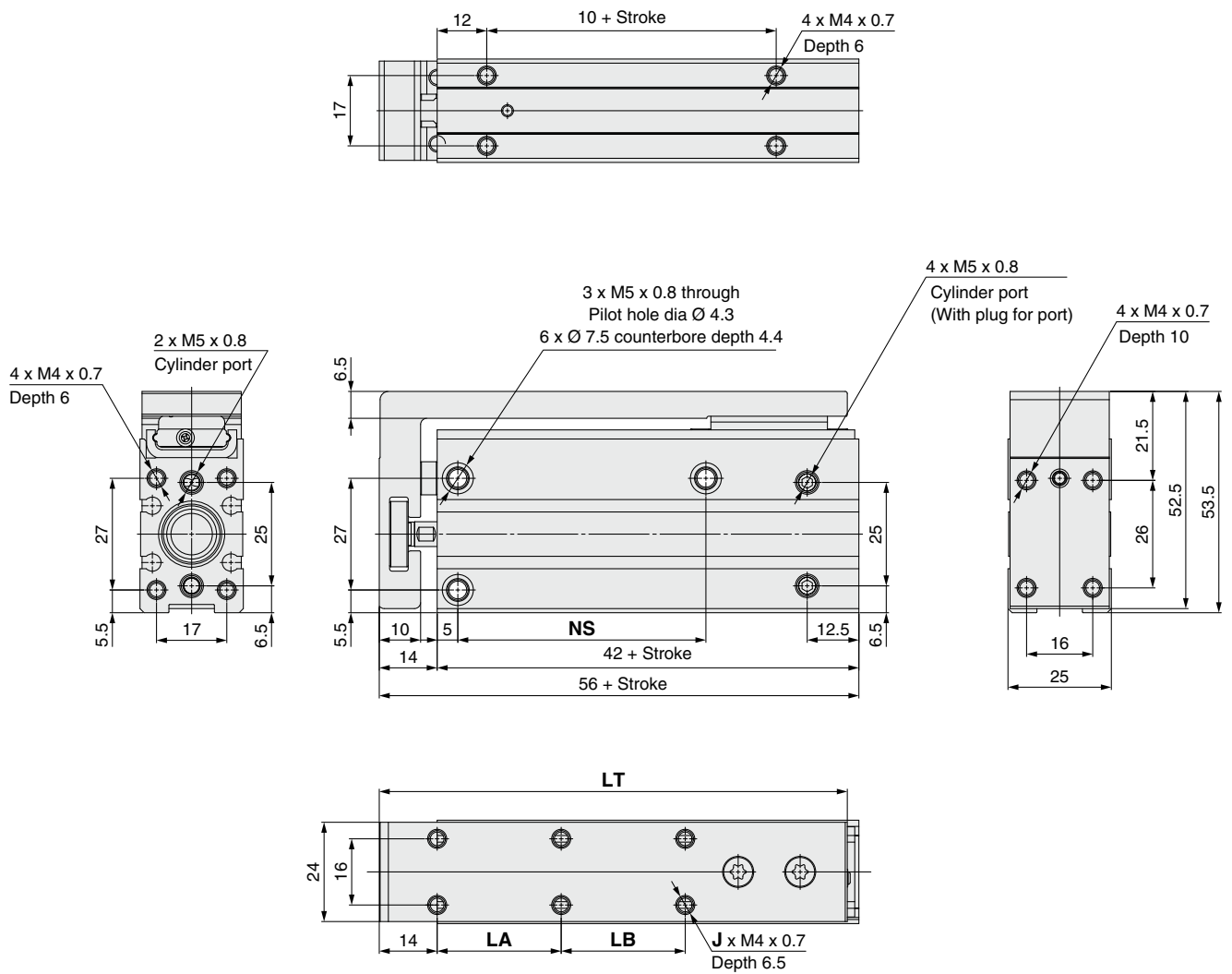

* Refer to the operation manual for compact slide mounting, workpiece mounting, and changing port locations.

Stroke	J	LA	LB	LT	NS
5	4	10	—	58	20
10	4	10	—	63	20
15	4	20	—	68	30
20	4	20	—	73	30
25	4	30	—	78	40
30	4	30	—	83	40
40	6	20	20	93	50
50	6	25	25	103	60
60	6	30	30	113	60

Dimensions: \varnothing 16

75, 100 and 125 mm stroke

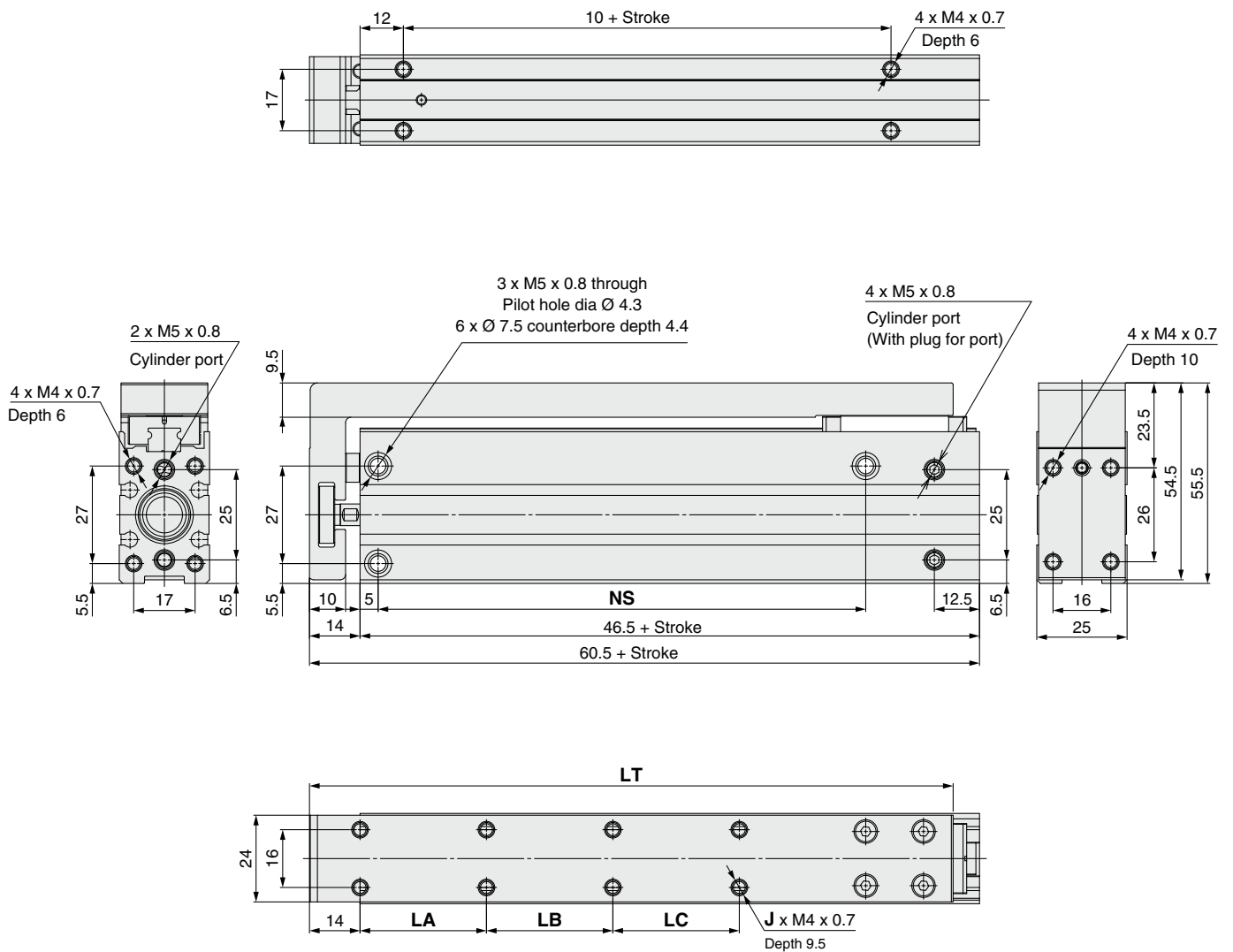

* Refer to the operation manual for compact slide mounting, workpiece mounting, and changing port locations.

Stroke	J	LA	LB	LC	LT	NS
75	6	30	30	—	128.5	75
100	6	30	30	—	153.5	100
125	8	35	35	35	178.5	135

[mm]

MXH2 Series

Dimensions: \varnothing 20

5 to 60 mm stroke

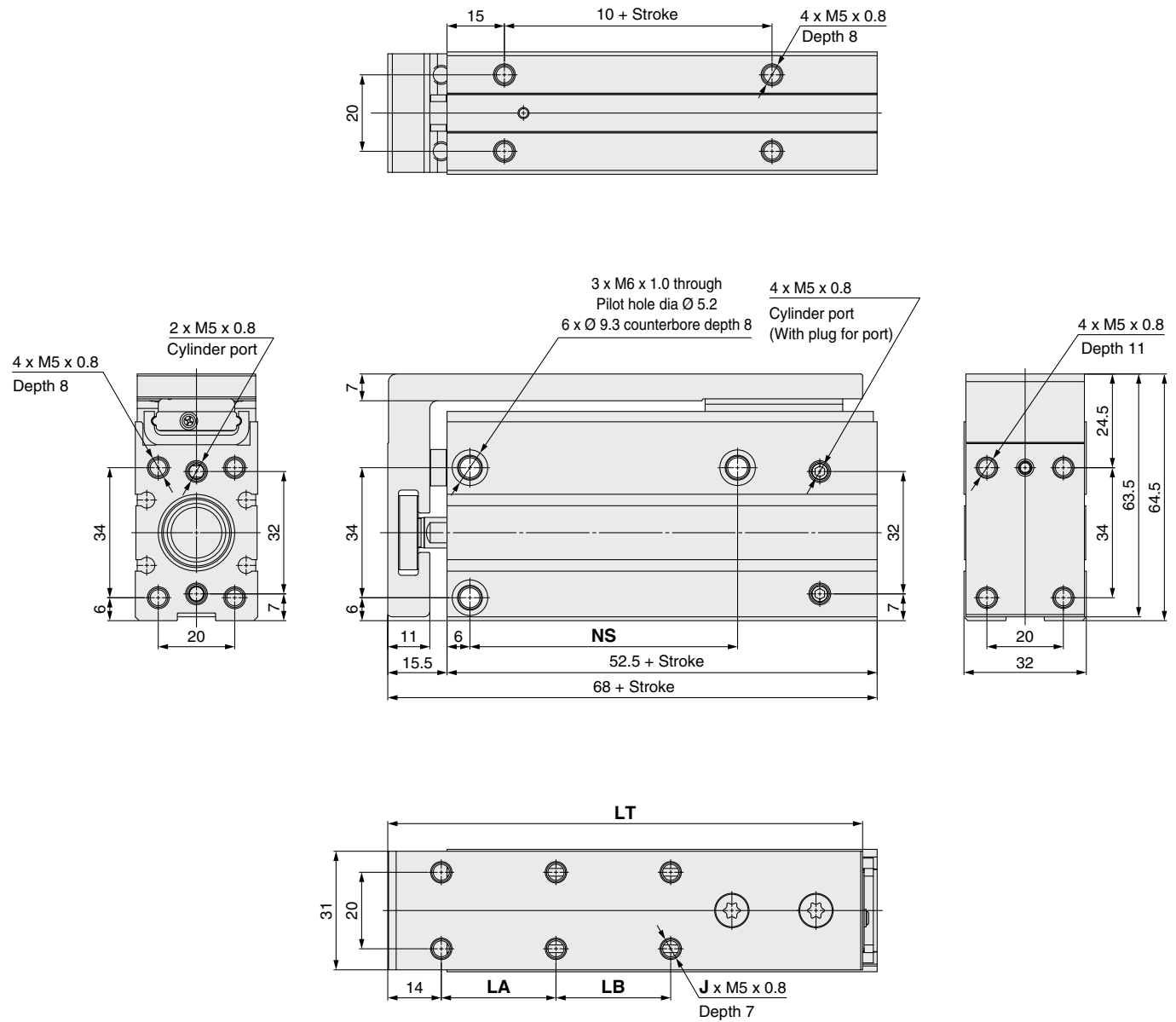

* Refer to the operation manual for compact slide mounting, workpiece mounting, and changing port locations.

Stroke	J	LA	LB	LT	NS
5	4	10	—	69	20
10	4	10	—	74	20
15	4	20	—	79	25
20	4	20	—	84	25
25	4	30	—	89	40
30	4	30	—	94	40
40	6	20	20	104	50
50	6	25	25	114	70
60	6	30	30	124	70

Dimensions: \varnothing 20

75, 100, 125 and 150 mm stroke

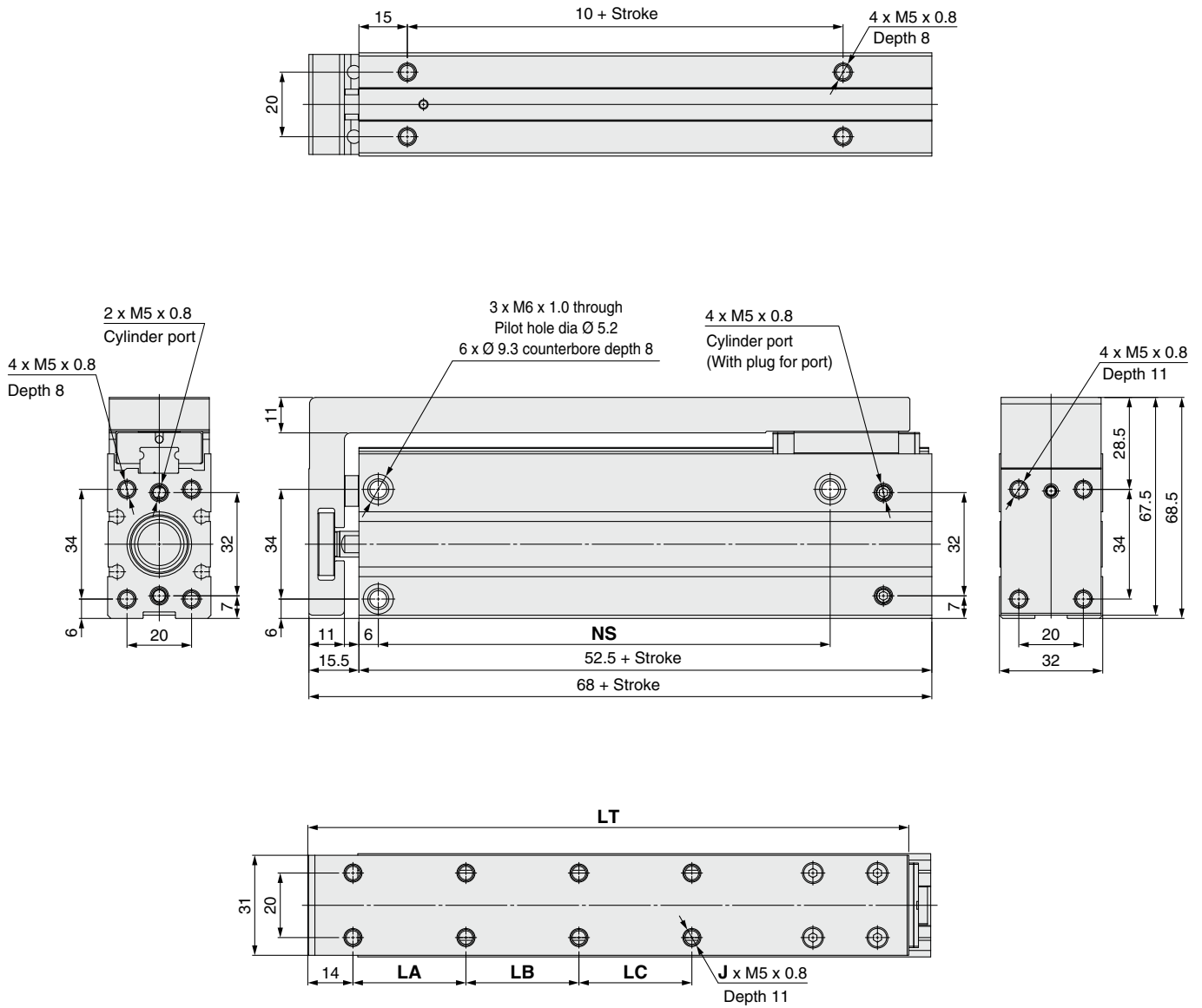

* Refer to the operation manual for compact slide mounting, workpiece mounting, and changing port locations.

Stroke	J	LA	LB	LC	LT	NS
75	6	30	30	—	136.5	90
100	6	30	30	—	161.5	115
125	8	35	35	35	186.5	140
150	8	35	35	35	211.5	165

[mm]

MXH2 Series

Dimensions: $\varnothing 25$

5 to 60 mm stroke

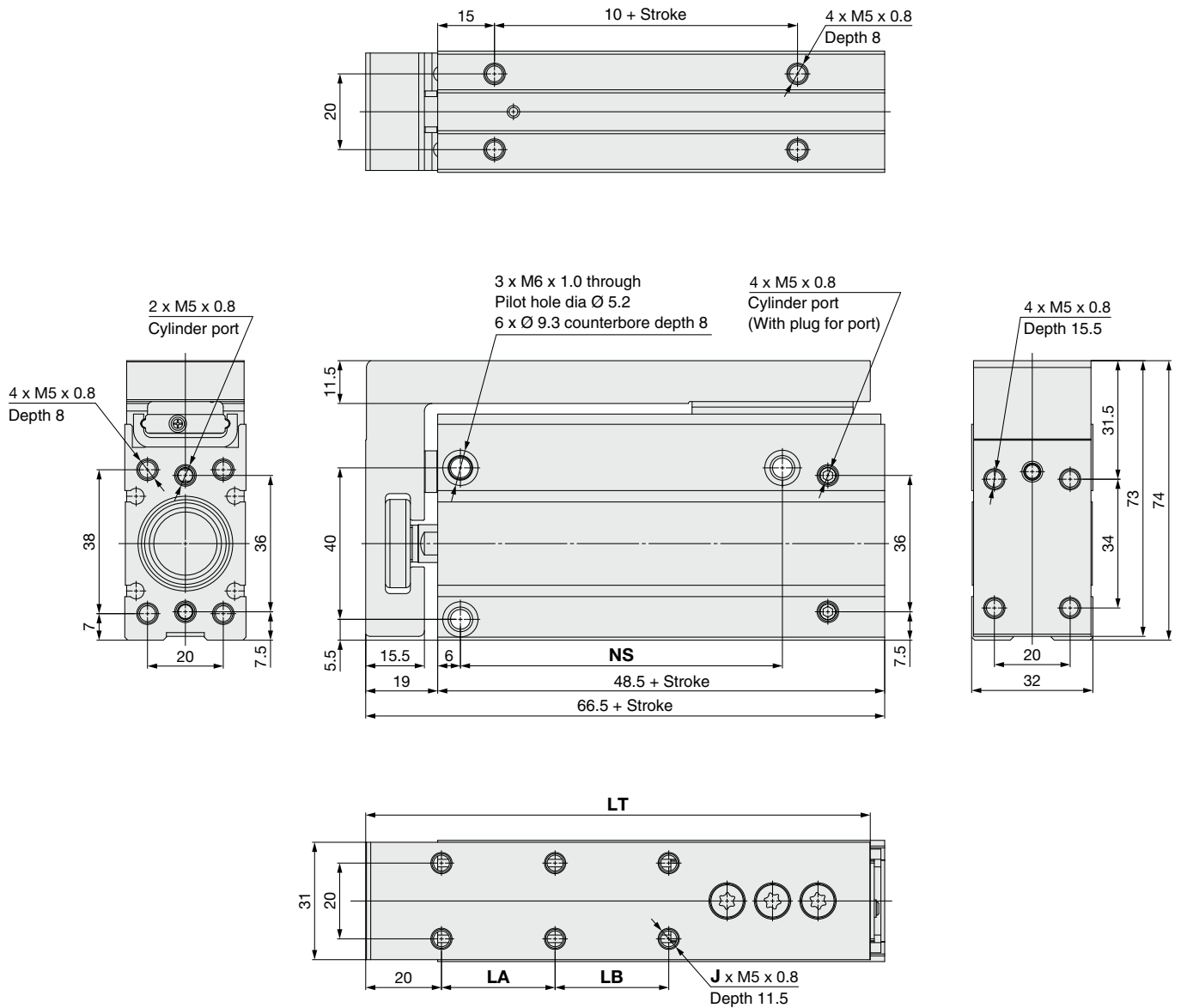

* Refer to the operation manual for compact slide mounting, workpiece mounting, and changing port locations.

Stroke	L1	L2	L3	J	LA	LB	LT	NS
5, 10	87	68	30	4	10	—	83.5	35
15, 20	97	78	40	4	20	—	93.5	45
25, 30	107	88	50	4	30	—	103.5	55
40	117	98	60	6	20	20	113.5	65
50	127	108	70	6	25	25	123.5	75
60	137	118	80	6	30	30	133.5	85

[mm]

Dimensions: $\varnothing 25$

75, 100, 125 and 150 mm stroke

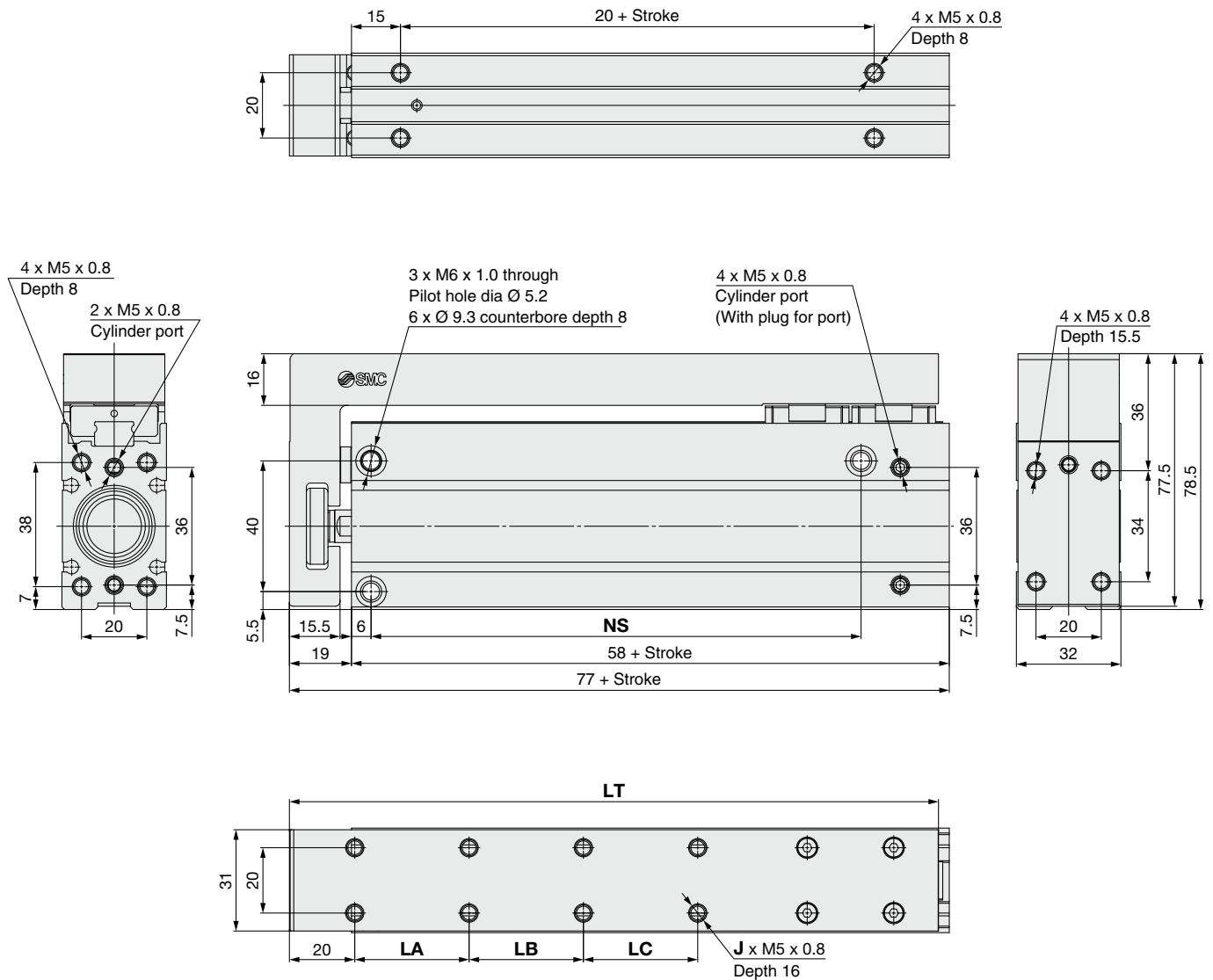

* Refer to the operation manual for compact slide mounting, workpiece mounting, and changing port locations.

Stroke	J	LA	LB	LC	LT	NS
75	6	30	30	—	149	100
100	6	30	30	—	174	125
125	8	35	35	35	199	150
150	8	35	35	35	224	175

[mm]

MXH2 Series

Auto Switch Mounting

Minimum Stroke for Auto Switch Mounting

Number of auto switches mounted	Applicable auto switch model		
	D-M9□, M9□V	D-M9□W, M9□WV D-M9□A, M9□AV	D-A9□, A9□V
1 pc.	5	5	5
2 pcs.	5	10	10

Auto Switch Proper Mounting Position (Detection at Stroke End) and Mounting Height

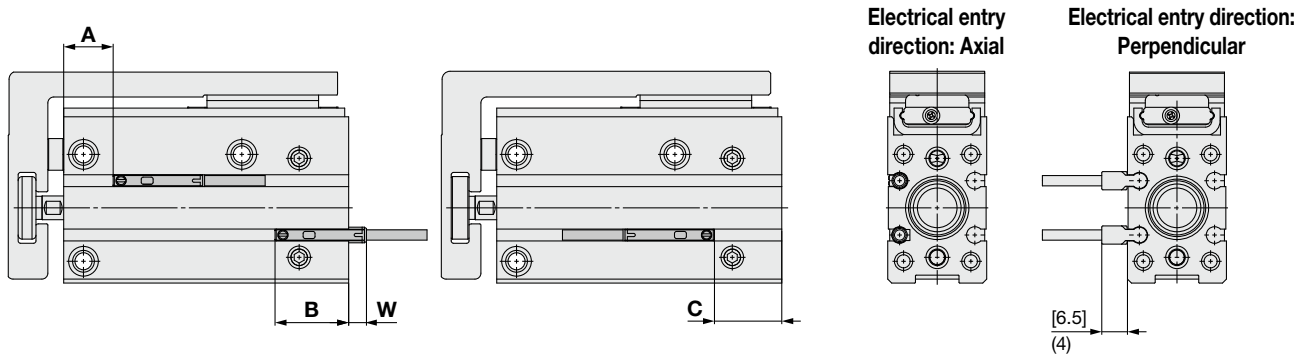

[]: Value of the the D-M9□V, D-M9□WV, and D-M9□AV
(): Value of the D-A9□V

Bore size [mm]	D-M9□ D-M9□W D-M9□V D-M9□WV D-M9□A D-M9□AV				D-A9□ D-A9□V			
	A	B	C	W	A	B	C	W
6	12.0	18.5	6.5	5.5	8.0	22.5	2.5	2.0
10*1	10.0	24.5 (26.5)	12.5 (14.5)	—	6.0	28.5 (30.5)	8.5 (10.5)	—
16*1	12.0	29.0 (33.5)	17.0 (21.5)	—	8.0	33.0 (37.5)	13.0 (17.5)	—
20	17.5	36.0	24.0	—	13.5	40.0	20.0	—
25*2	18.0	39.5 (44.5)	27.5 (32.5)	—	14.0	43.5 (48.5)	23.5 (28.5)	—

*1 Values in brackets () in the tables are dimensions for 75 mm or longer strokes.

*2 The values in brackets for size Ø 25 are the dimensions for 5, 15, and 25 mm strokes.

* The "W" values in the table indicate the max. auto switch protrusion from the cylinder end surface. Adjust the auto switch after confirming the operating conditions in the actual setting.

* In the case of models with 5 and 10 strokes, the auto switch may not turn off due to operating range or two auto switches may turn on simultaneously. Fix auto switches outside 1 to 4 mm further than the values in the table above. (If one auto switch is used, make sure that it turns ON and OFF properly; If two auto switches are used, make sure that both auto switches turn ON.)

Operating Range

Auto switch model	Bore size [mm]				
	6	10	16	20	25
D-M9□, M9□V D-M9□W, M9□WV D-M9□A, M9□AV	3	3.5	5	6	6
D-A9□, A9□V	5	6	9	11	10.5

* Values which include hysteresis are for guideline purposes only, they are not a guarantee (assuming approx. ±30 % dispersion) and may change substantially depending on the ambient environment.

⚠ Auto Switch Mounting

■ When installing in close proximity to each other

When the compact slide with the D-A9□ or D-M9□ auto switch is used, the auto switches could activate unintentionally if the space between the products is less than the dimension shown in Table 1. Therefore, make sure to provide at least this much clearance. Due to unavoidable circumstances, if they must be used with less distance than the dimensions given in the table on the right, the cylinders must be shielded. Therefore, affix a steel plate or a magnetic shielding plate (MU-S025) to the area on the cylinder that corresponds to the adjacent auto switch. The auto switch could activate unintentionally if a shielding plate is not used.

Table 1. [mm]

Bore size [mm]	d	L
6	5	21
10	5	25
16	10	35
20	15	47
25	15	47

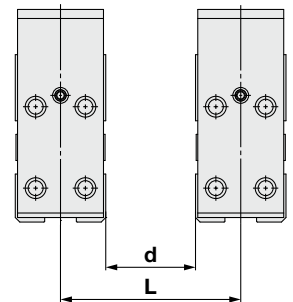

Dimensions of a shielding plate (MU-S025) that is sold separately are indicated as reference.



Material: Ferrite stainless steel,
Thickness: 0.3 mm
Since the back side is treated with adhesive, it is possible to attach to the cylinder.

■ Side ported type

When using the side ported type, it is not possible to mount perpendicular type D-A9□V or M9□V auto switches on the side to which the piping is connected.

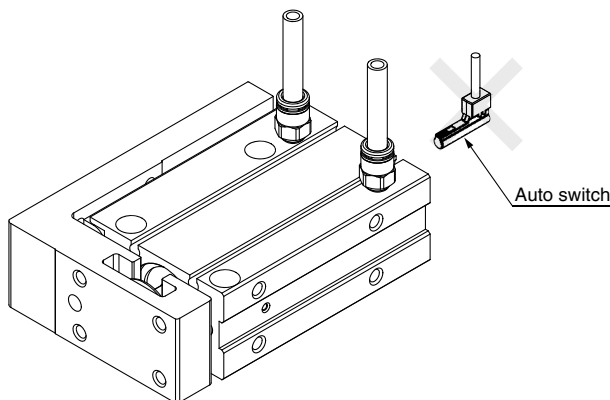

Other than the applicable auto switches listed in "How to Order", the following auto switches can be mounted.

* Normally closed (NC = b contact) solid state auto switches (D-M9□E(V)) are also available. Refer to the **Web Catalogue** for details.

MXH2 Series Simple Specials

The following changes are dealt with through the Simple Specials System.

Please contact your local sales representative for more details.

1 Tapped Hole, Drilled Hole, Pinned Hole Machined Additionally

Symbol
-XC79

This simple special is meant for machining additionally tapped hole, drilled hole, and pinned hole, as requested from customer, on parts designed largely for mounting a workpiece, etc. in the combined air cylinders. But, for each model, since they have the portions which are impossible to machine additionally, refer to the additional machining limitation.

Applicable Series and Component Parts Machined Additionally

Applicable series	Component parts applicable for additional machining
MXH2	Table

⚠ Precautions

- We cannot take any responsibility as for the intensity of holes machined additionally and the effects of decreased intensity for the product itself.
- It will not be plated again for the machined part additionally.
- Be sure to fill in "through" for through-hole, and "effective depth" for blind hole.
- When using by machining through-hole additionally, ensure that the tip of the bolt, etc. for mounting workpiece should not stick into the cylinder side. It may result in an unexpected problem.
- Use caution not to interfere the current mounting hole on the standard products with the hole to be machined additionally. But it is possible to drill additionally the larger size of hole at the same position as the current hole.

Common Complementary Explanation/Holes which can be additionally machined are the following 3 types.

<p>Tapped hole</p> <p>Designated nominal diameter and tapped hole of a pitch are machined additionally. (Maximum nominal thread diameter M20) Blind hole is deep into the bottom of prepared hole which sums up A to C in the figure below in contrast to the effective depth of tapped hole. When there is a condition which does not allow through-hole, etc., leave sufficient thickness in the inner part of hole.</p> <p style="font-size: small;">* P stands for thread pitch.</p>	<p>Drilled hole</p> <p>Drilled hole of a designated internal diameter is machined. (Maximum hole diameter 20 mm) If you wish for blind hole, instruct us with effective depth. (Refer to the figure below.) Besides, dimensional accuracy for internal diameter will be ± 0.2 mm.</p>	<p>Pinned hole</p> <p>Pinned hole of a designated diameter (reamer hole) is machined. (Maximum hole diameter 20 mm) Internal dimension tolerates H7 tolerance to the designated hole diameter. (Refer to the table below.)</p> <table border="1" style="width: 100%; font-size: x-small; border-collapse: collapse;"> <thead> <tr> <th>Hole dia.</th> <th>3 or less</th> <th>Over 3 to 6</th> <th>Over 6 to 10</th> <th>Over 10 to 18</th> <th>Over 18 to 20</th> </tr> </thead> <tbody> <tr> <td>Tolerance</td> <td>+0.01 0</td> <td>+0.012 0</td> <td>+0.015 0</td> <td>+0.018 0</td> <td>+0.021 0</td> </tr> </tbody> </table>	Hole dia.	3 or less	Over 3 to 6	Over 6 to 10	Over 10 to 18	Over 18 to 20	Tolerance	+0.01 0	+0.012 0	+0.015 0	+0.018 0	+0.021 0
Hole dia.	3 or less	Over 3 to 6	Over 6 to 10	Over 10 to 18	Over 18 to 20									
Tolerance	+0.01 0	+0.012 0	+0.015 0	+0.018 0	+0.021 0									

Limitation for Machining Additionally/Since the slanted lines denote the restricted range for machining additionally, design the dimensions, referring to below.

MXH2 series Table material: Aluminum

Dimensional Range Not Possible to Machine Additionally [mm]			
Bore size [mm]	LX	LY	LZ
6	28	11	8
10	31	14	8.5
16	39	19	8.5
20	48	23	10.5
25	54	28.5	10.5

MXH2 Series

Made to Order Common Specifications

Please contact SMC for detailed dimensions, specifications, and delivery times.



1 Low-speed Cylinder (5 to 50 mm/s)

Symbol
-XB13

Stick-slip phenomenon can be prevented, and smooth operation can be achieved even at lower driving speeds between 5 to 50 mm/s.

Description	Model	Action	Note
Compact slide	MXH2	Double acting	

How to Order

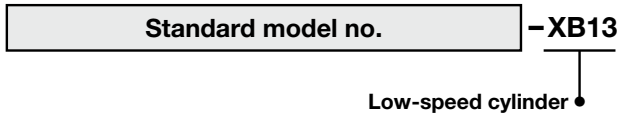

- * Operate without lubrication from a pneumatic system lubricator.
- * For the speed adjustment, use speed controllers for controlling at lower speeds. (AS-FM/AS-M series)

Specifications

Piston speed	5 to 50 mm/s
Dimensions	Same as the standard type
Additional specifications	Same as the standard type

2 Special Port Location

Symbol
-XC3□

Cylinder with a modified port position in comparison to the standard type.

Description	Model	Action	Note
Compact slide	MXH2	Double acting	

How to Order

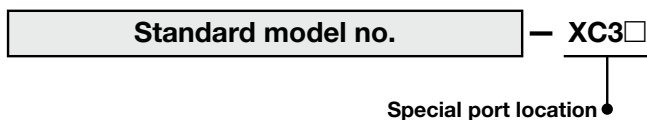

Specifications: Same as the standard type

The port location of a standard product is in the axial direction, and it is shipped as plugged on both sides. However, side ported types can be ordered. A shifting of the plugs is not required by the customer.

Relation between Port Location and Plug Location

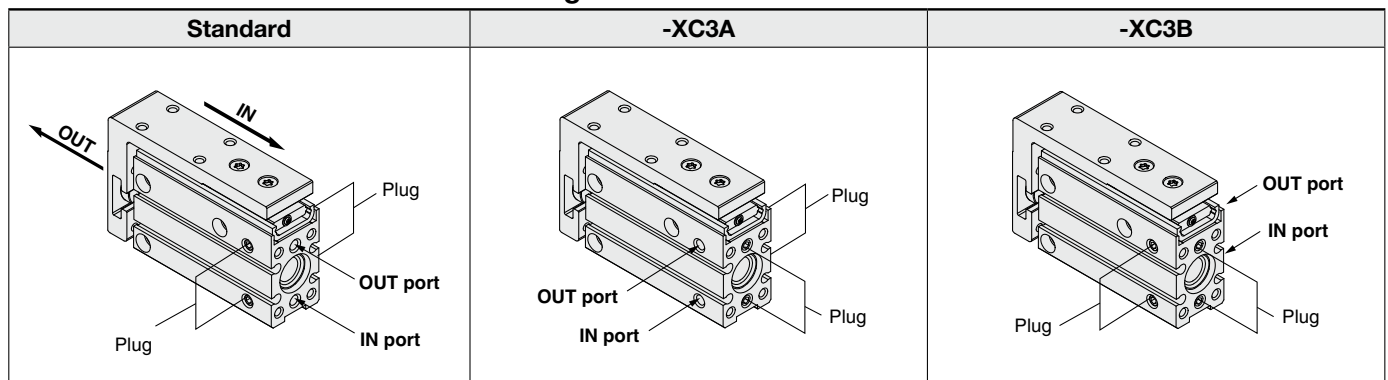

3 Intermediate Stroke (Spacer type) Symbol **-XC19**

Dealing with intermediate strokes by installing a spacer with the standard stroke cylinder.

Description	Model	Action	Note
Compact slide	MXH2	Double acting	Available through the use of 5 or 10 mm spacers

How to Order

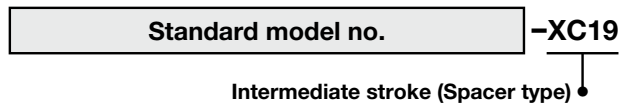

Specifications

Intermediate stroke Product dimensions and mounting dimensions	Refer to Table 1 below.
Specifications other than the above	Same as the standard type

Table 1. Intermediate Stroke (Spacer type)

Intermediate stroke	Stroke																
	35	45	55	65	70	80	85	90	95	105	110	115	120	130	135	140	145
Product dimensions and mounting dimensions	Same as 40 mm stroke	Same as 50 mm stroke	Same as 60 mm stroke	Same as 75 mm stroke		Same as 100 mm stroke				Same as 125 mm stroke				Same as 150 mm stroke			

- Dealing with it by installing a 5 mm or 10 mm width spacer with the standard stroke cylinder
- Intermediate strokes not listed in the table are available as a special order.

4 Fluororubber Seals Symbol **-XC22**

Description	Model	Action	Note
Compact slide	MXH2	Double acting	

How to Order

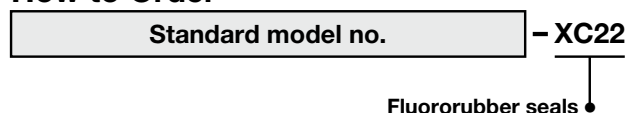

Specifications

Seal material	Fluororubber
Ambient temperature range	*1 With auto switch : -10 °C to 60 °C Without auto switch: -10 °C to 70 °C (No freezing)
Specifications that are not listed above Product dimensions and mounting dimensions	Same as the standard type

- *1 The type of chemical and the operating temperature may not allow the use of this product.

Safety Instructions

These safety instructions are intended to prevent hazardous situations and/or equipment damage. These instructions indicate the level of potential hazard with the labels of “Caution,” “Warning” or “Danger.” They are all important notes for safety and must be followed in addition to International Standards (ISO/IEC) ¹⁾, and other safety regulations.

Danger:

Danger indicates a hazard with a high level of risk which, if not avoided, will result in death or serious injury.

Warning:

Warning indicates a hazard with a medium level of risk which, if not avoided, could result in death or serious injury.

Caution:

Caution indicates a hazard with a low level of risk which, if not avoided, could result in minor or moderate injury.

- 1) ISO 4414: Pneumatic fluid power – General rules and safety requirements for systems and their components.
- ISO 4413: Hydraulic fluid power – General rules and safety requirements for systems and their components.
- IEC 60204-1: Safety of machinery – Electrical equipment of machines. (Part 1: General requirements)
- ISO 10218-1: Robots and robotic devices - Safety requirements for industrial robots - Part 1: Robots.
- etc.

Warning

1. The compatibility of the product is the responsibility of the person who designs the equipment or decides its specifications.

Since the product specified here is used under various operating conditions, its compatibility with specific equipment must be decided by the person who designs the equipment or decides its specifications based on necessary analysis and test results. The expected performance and safety assurance of the equipment will be the responsibility of the person who has determined its compatibility with the product. This person should also continuously review all specifications of the product referring to its latest catalogue information, with a view to giving due consideration to any possibility of equipment failure when configuring the equipment.

2. Only personnel with appropriate training should operate machinery and equipment.

The product specified here may become unsafe if handled incorrectly. The assembly, operation and maintenance of machines or equipment including our products must be performed by an operator who is appropriately trained and experienced.

3. Do not service or attempt to remove product and machinery/equipment until safety is confirmed.

1. The inspection and maintenance of machinery/equipment should only be performed after measures to prevent falling or runaway of the driven objects have been confirmed.
2. When the product is to be removed, confirm that the safety measures as mentioned above are implemented and the power from any appropriate source is cut, and read and understand the specific product precautions of all relevant products carefully.
3. Before machinery/equipment is restarted, take measures to prevent unexpected operation and malfunction.

4. Our products cannot be used beyond their specifications. Our products are not developed, designed, and manufactured to be used under the following conditions or environments.

Use under such conditions or environments is not covered.

1. Conditions and environments outside of the given specifications, or use outdoors or in a place exposed to direct sunlight.
2. Use for nuclear power, railways, aviation, space equipment, ships, vehicles, military application, equipment affecting human life, body, and property, fuel equipment, entertainment equipment, emergency shut-off circuits, press clutches, brake circuits, safety equipment, etc., and use for applications that do not conform to standard specifications such as catalogues and operation manuals.
3. Use for interlock circuits, except for use with double interlock such as installing a mechanical protection function in case of failure. Please periodically inspect the product to confirm that the product is operating properly.

Caution

We develop, design, and manufacture our products to be used for automatic control equipment, and provide them for peaceful use in manufacturing industries.

Use in non-manufacturing industries is not covered.

Products we manufacture and sell cannot be used for the purpose of transactions or certification specified in the Measurement Act.

The new Measurement Act prohibits use of any unit other than SI units in Japan.

Limited warranty and Disclaimer/Compliance Requirements

The product used is subject to the following “Limited warranty and Disclaimer” and “Compliance Requirements”. Read and accept them before using the product.

Limited warranty and Disclaimer

1. The warranty period of the product is 1 year in service or 1.5 years after the product is delivered, whichever is first. ²⁾ Also, the product may have specified durability, running distance or replacement parts. Please consult your nearest sales branch.
2. For any failure or damage reported within the warranty period which is clearly our responsibility, a replacement product or necessary parts will be provided. This limited warranty applies only to our product independently, and not to any other damage incurred due to the failure of the product.
3. Prior to using SMC products, please read and understand the warranty terms and disclaimers noted in the specified catalogue for the particular products.
- 2) Vacuum pads are excluded from this 1 year warranty.
A vacuum pad is a consumable part, so it is warranted for a year after it is delivered. Also, even within the warranty period, the wear of a product due to the use of the vacuum pad or failure due to the deterioration of rubber material are not covered by the limited warranty.

Compliance Requirements

1. The use of SMC products with production equipment for the manufacture of weapons of mass destruction (WMD) or any other weapon is strictly prohibited.
2. The exports of SMC products or technology from one country to another are governed by the relevant security laws and regulations of the countries involved in the transaction. Prior to the shipment of a SMC product to another country, assure that all local rules governing that export are known and followed.

Safety Instructions

Be sure to read “Handling Precautions for SMC Products” (M-E03-3) before using.

Revision History

Edition B - Size Ø 25 has been added.
- 3 times better durability has been added.

SMC Corporation (Europe)

Austria	+43 (0)2262622800	www.smc.at	office@smc.at
Belgium	+32 (0)33551464	www.smc.be	info@smc.be
Bulgaria	+359 (0)2807670	www.smc.bg	office@smc.bg
Croatia	+385 (0)13707288	www.smc.hr	office@smc.hr
Czech Republic	+420 541424611	www.smc.cz	office@smc.cz
Denmark	+45 70252900	www.smc.dk.com	smc@smc.dk.com
Estonia	+372 651 0370	www.smcee.ee	info@smcee.ee
Finland	+358 207513513	www.smc.fi	smc.fi@smc.fi
France	+33 (0)164761000	www.smc-france.fr	supportclient@smc-france.fr
Germany	+49 (0)61034020	www.smc.de	info@smc.de
Greece	+30 210 2717265	www.smchellas.gr	sales@smchellas.gr
Hungary	+36 23513000	www.smc.hu	office@smc.hu
Ireland	+353 (0)14039000	www.smcautomation.ie	sales@smcautomation.ie
Italy	+39 03990691	www.smcitalia.it	mailbox@smcitalia.it
Latvia	+371 67817700	www.smc.lv	info@smc.lv

Lithuania	+370 5 2308118	www.smclt.lt	info@smclt.lt
Netherlands	+31 (0)205318888	www.smc.nl	info@smc.nl
Norway	+47 67129020	www.smc-norge.no	post@smc-norge.no
Poland	+48 222119600	www.smc.pl	sales@smc.pl
Portugal	+351 214724500	www.smc.eu	apoioclientept@smc.smces.es
Romania	+40 213205111	www.smcromania.ro	smcromania@smcromania.ro
Russia	+7 (812)3036600	www.smc.eu	sales@smcru.com
Slovakia	+421 (0)413213212	www.smc.sk	office@smc.sk
Slovenia	+386 (0)73885412	www.smc.si	office@smc.si
Spain	+34 945184100	www.smc.eu	post@smc.smces.es
Sweden	+46 (0)86031240	www.smc.nu	smc@smc.nu
Switzerland	+41 (0)523963131	www.smc.ch	info@smc.ch
Turkey	+90 212 489 0 440	www.smcturkey.com.tr	info@smcturkey.com.tr
UK	+44 (0)845 121 5122	www.smc.uk	sales@smc.uk

South Africa +27 10 900 1233 www.smcza.co.za zasales@smcza.co.za