

# Air Cylinder

Ø 32, Ø 40, Ø 50, Ø 63, Ø 80, Ø 100, Ø 125

New

RoHS

Adopts an air cushion + rubber bumper structure

3 times better durability

\* Based on SMC's test conditions

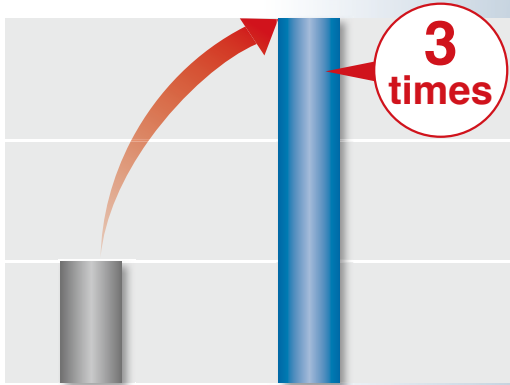

Existing MB

New MB2



## Allowable kinetic energy: Max. 1.5 times

Full stroke time:  
Reduced by 20 %

Piston speed  
increased by 20 %

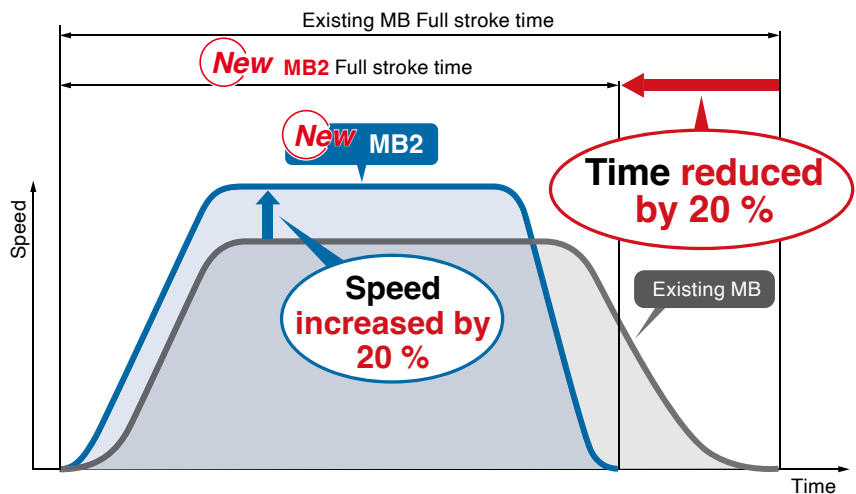

### Downsizing

- It is possible to go down 1 cylinder bore size while maintaining the same allowable kinetic energy.
- Contributes to the downsizing of equipment
- CO<sub>2</sub> emissions (Air consumption) reduced by 38 %

\* The figure shows bore size 80 downsized to bore size 63.

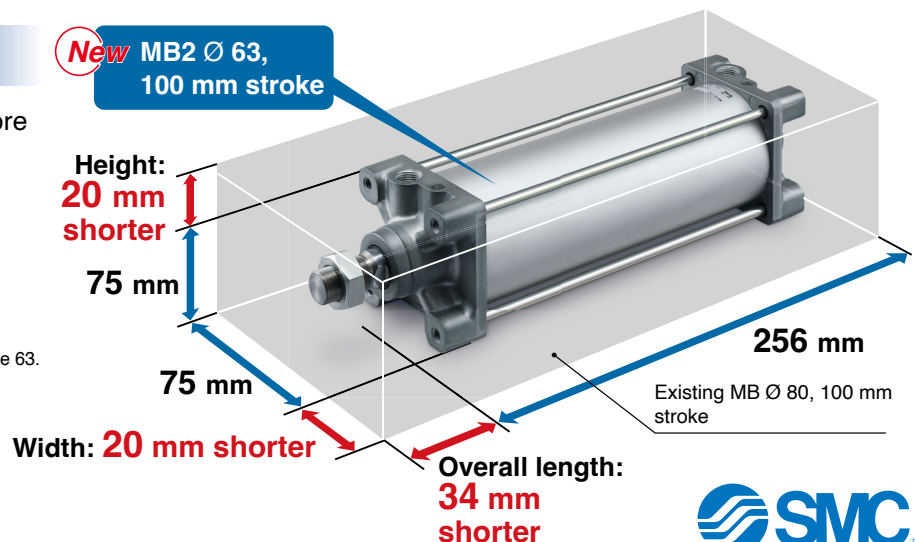

MB2 Series



CAT.EUS20-297A-UK

## Allowable kinetic energy: Max 1.5 times

Has the same kinetic energy as the existing MB series product which is 1 size larger

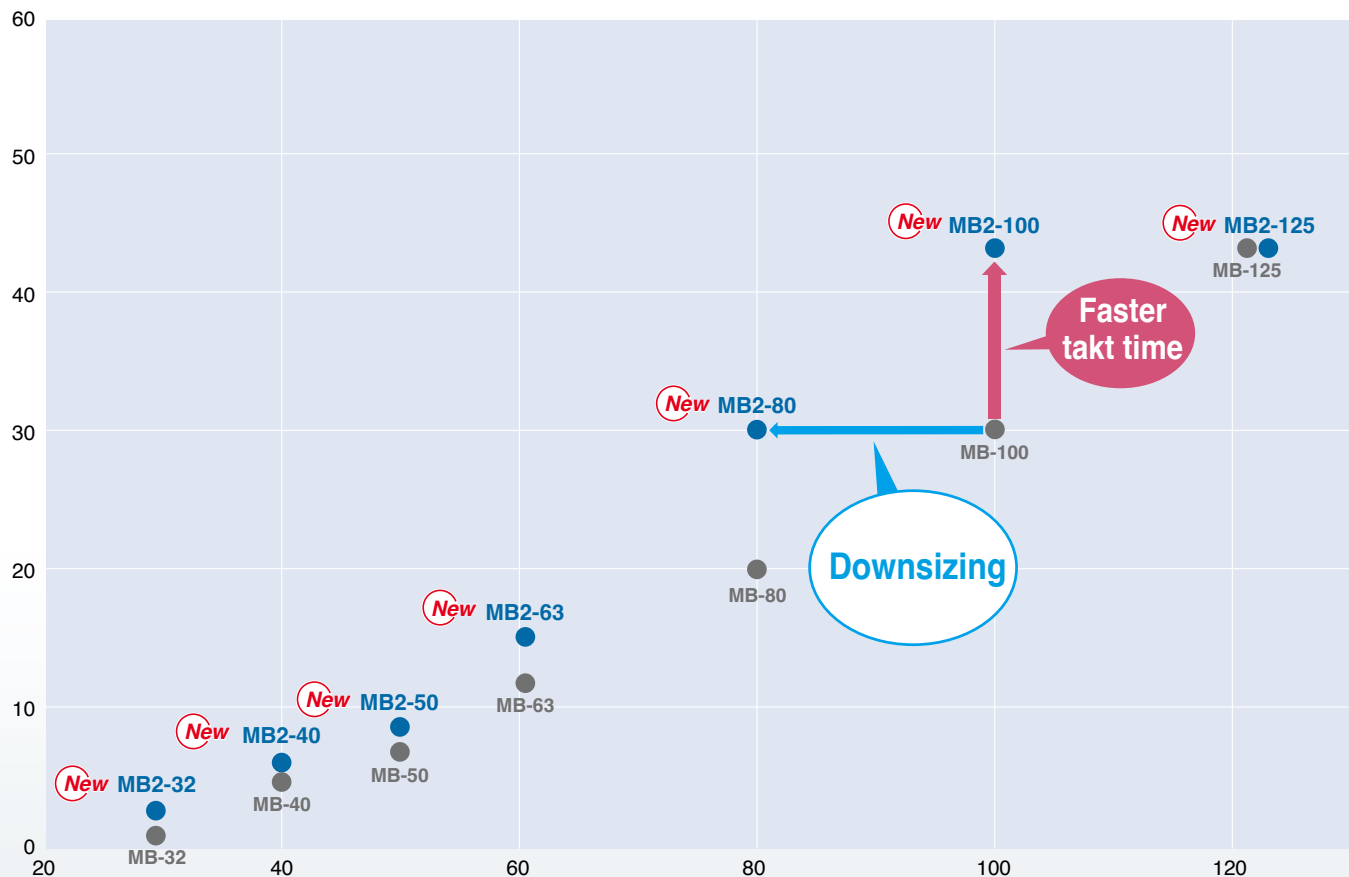

Allowable Kinetic Energy Unit: J

Bore size [mm]	Existing MB	New MB2
32	2.2	3.3
40	3.4	5.1
50	5.9	8.9
63	11.0	16.5
80	20.0	30.0
100	29.0	43.5
125	45.0	45.0

**Example** 75 kg is transferred horizontally with a piston speed of 800 mm/s → kinetic energy = 24 J

**Existing MB**

While the output and load factor are sufficient with bore size Ø 80/supply pressure 0.5 MPa, bore size Ø 100 is selected as the max. allowable kinetic energy is only 20.0 J for bore size Ø 80.

**New MB2**

The allowable kinetic energy is 30.0 J, so bore size Ø 80 can be selected.

→ Increased energy saving is possible due to downsizing.

## CO2 emissions (Air consumption) can be reduced by up to 39 %.

CO2 emissions (Air consumption) can be reduced due to downsizing. (Air consumption for one cycle) [L]

Bore size [mm]	Ø 32	Ø 40	Ø 50	Ø 63	Ø 80	Ø 100	Ø 125
Air consumption [L]	1.3	2.1	3.3	5.3	8.6	13.5	21.4

\* At 0.5 MPa supply pressure and 150 mm stroke



**Reduces cushion stroke time**

The air cushion + rubber bumper combined structure allows for improved cushioning performance.

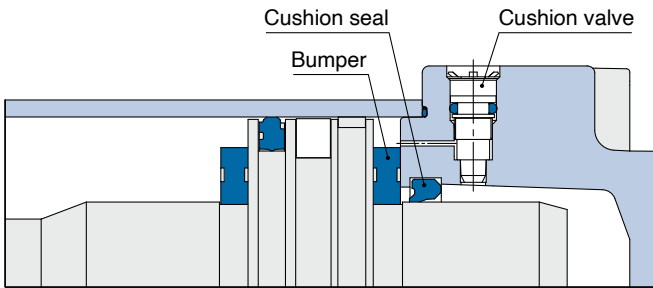

**Reduces the metal noise that occurs when the piston stops**

**Various switches such as small auto switches and magnetic field-resistant auto switches can be mounted.**

Small auto switches

- D-M9□
- D-A9□

Magnetic field-resistant auto switches

- D-P3DWA
- D-P4DW

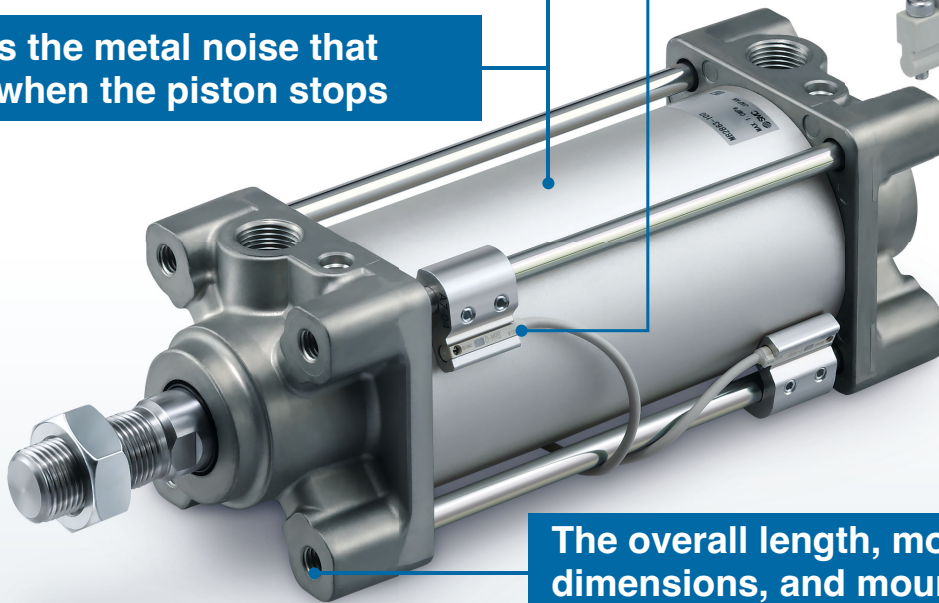
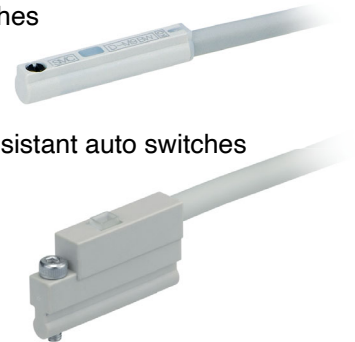

**The overall length, mounting dimensions, and mounting brackets are interchangeable with the existing MB series product.**

**Part numbers for products with a rod end bracket and/or a pivot bracket are available.**

Time saving is possible as the cylinder and brackets do not need to be ordered separately.

\* Rod end brackets and pivot brackets are shipped together with the product but do not come assembled.

Example) **MDB2** **D** 40-100- **N** **V** -M9BW

● Mounting

Pivot bracket	
—	No bracket
<b>N</b>	Pivot bracket included

\* Applicable only to D (Double clevis) and T (Trunnion) mounting types

Rod end bracket	
—	No bracket
<b>V</b>	Single knuckle joint
<b>W</b>	Double knuckle joint
<b>Q</b>	Rod end

Double clevis



Trunnion

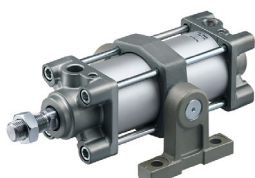

With rod end bracket

**V:** Single knuckle joint



**W:** Double knuckle joint

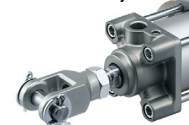

**Q:** Rod end



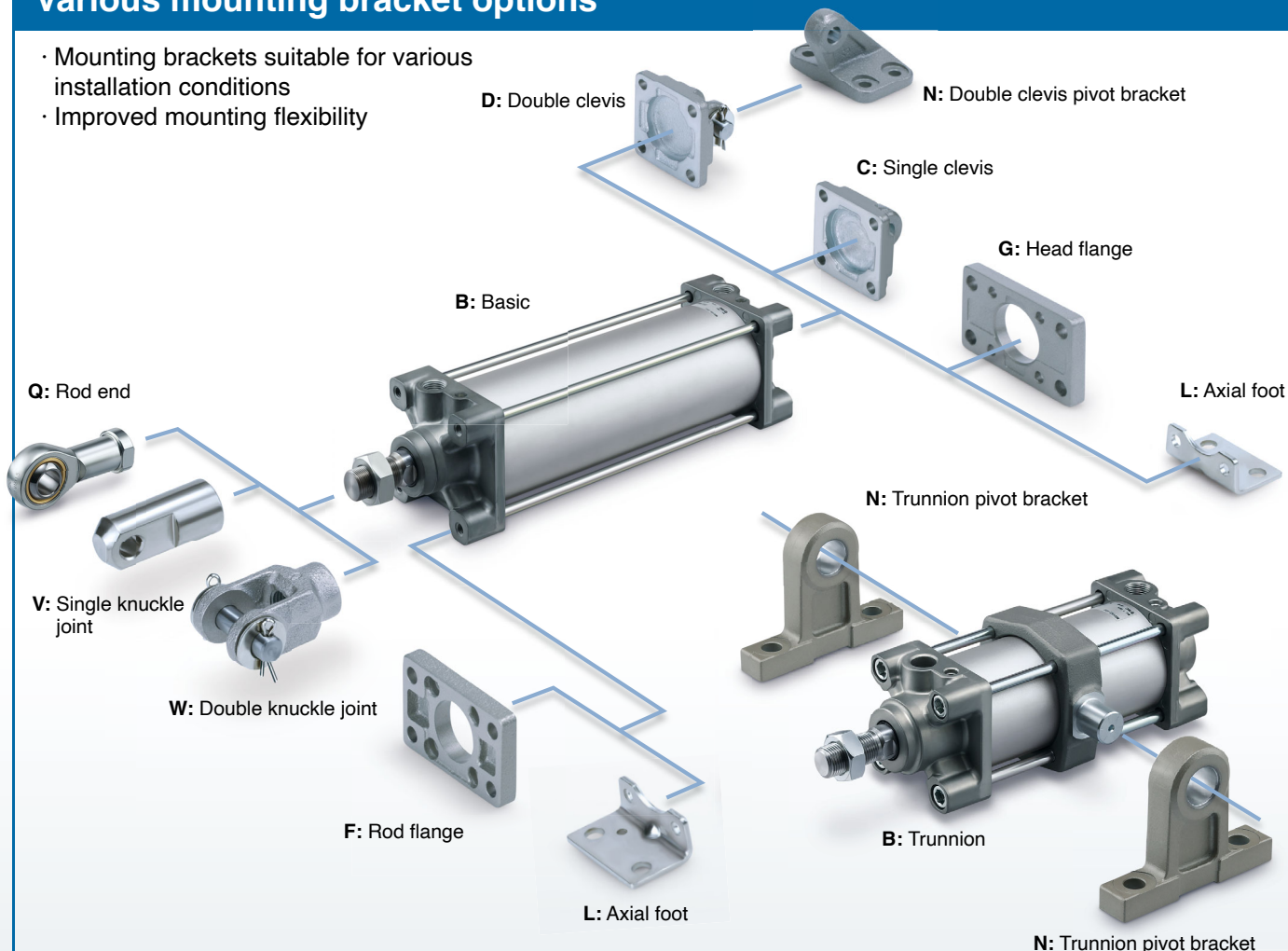

## Various mounting bracket options

- Mounting brackets suitable for various installation conditions
- Improved mounting flexibility



## Series Variations

Series	Type	Cushion	Bore size [mm]							Rod boot	Page
			32	40	50	63	80	100	125		
<b>Standard Single rod MB2 Series</b> 	Double acting, Single rod	Air cushion + Rubber bumper	●	●	●	●	●	●	●	●	4
<b>Standard Double rod MB2W Series</b> 	Double acting, Double rod	Air cushion + Rubber bumper	●	●	●	●	●	●	●	●	

## CONTENTS

### Standard Type: Double Acting, Single Rod **MB2 Series**

How to Order .....	p. 4
Specifications .....	p. 5
Replacement Parts .....	p. 7
Dimensions .....	p. 8
Rod End Bracket Dimensions .....	p. 12

### Standard Type: Double Acting, Double Rod **MB2W Series**

How to Order .....	p. 14
Specifications .....	p. 15
Replacement Parts .....	p. 17
Dimensions .....	p. 18

Auto Switch Mounting .....	p. 20
Safety Instructions .....	Back cover

# Air Cylinder: Standard Type Double Acting, Single Rod

## MB2 Series

RoHS

∅ 32, ∅ 40, ∅ 50, ∅ 63, ∅ 80, ∅ 100, ∅ 125

### How to Order

**With auto switch** **MDB2** **B** **32** **50** **M9BW**

**With auto switch**  
(Built-in magnet)

**Mounting**

<b>B</b>	Basic
<b>L</b>	Axial foot
<b>F</b>	Rod flange
<b>G</b>	Head flange
<b>C</b>	Single clevis
<b>D</b>	Double clevis
<b>T</b>	Trunnion

\* The trunnion type is mounted before shipment.  
\* Other mounting brackets are shipped together with the product.

**Bore size**

<b>32</b>	32 mm
<b>40</b>	40 mm
<b>50</b>	50 mm
<b>63</b>	63 mm
<b>80</b>	80 mm
<b>100</b>	100 mm
<b>125</b>	125 mm

**Port thread type**

—	Rc
<b>TN</b>	NPT
<b>TF</b>	G

**Pivot bracket**

—	No bracket
<b>N</b>	Pivot bracket

\* Only for D and T mounting types  
\* The bracket is shipped together with the product.  
\* For details, refer to page 11.

**Suffix (Rod boot)**

—	None
<b>J</b>	Nylon tarpaulin
<b>K</b>	Heat-resistant tarpaulin

\* For details, refer to page 6.

**Cylinder stroke [mm]**  
Refer to page 5 for standard strokes.

**Auto switch**

—	Without auto switch
---	---------------------

\* For applicable auto switches, refer to the table below.

—	2
<b>S</b>	1
<b>3</b>	3
<b>n</b>	n

**Rod end bracket**

—	No bracket (Rod end nut provided as standard)
<b>V</b>	Single knuckle joint
<b>W</b>	Double knuckle joint
<b>Q</b>	Rod end

\* A knuckle joint pin is not provided with the single knuckle joint.  
\* The bracket is shipped together with the product.  
\* For details, refer to page 12.

**\* For the ordering example of cylinder assembly, refer to page 5.**

### Applicable Auto Switches / Refer to the catalogue on [www.smc.eu](http://www.smc.eu) for further information on auto switches.

Type	Special function	Electrical entry	Indicator light	Wiring (Output)	Load voltage		Auto switch model		Lead wire length [m]					Pre-wired connector	Applicable load	
					DC	AC	Perpendicular	In-line	0.5 (—)	1 (M)	3 (L)	5 (Z)	None (N)			
Solid state auto switch	— — —	Grommet	Yes	3-wire (NPN)	24 V	5 V, 12 V	—	<b>M9NV</b>	<b>M9N</b>	●	●	●	○	—	○	IC circuit
				3-wire (PNP)				<b>M9PV</b>	<b>M9P</b>	●	●	●	○	—	○	
				2-wire				<b>M9BV</b>	<b>M9B</b>	●	●	●	○	—	○	
				3-wire (NPN)				<b>M9NWV</b>	<b>M9NW</b>	●	●	●	○	—	○	
	Diagnostic indication (2-colour indicator)	Grommet	Yes	3-wire (PNP)	24 V	5 V, 12 V	—	<b>M9PWV</b>	<b>M9PW</b>	●	●	●	○	—	○	IC circuit
				2-wire				<b>M9BWV</b>	<b>M9BW</b>	●	●	●	○	—	○	
				3-wire (NPN)				<b>M9NAV</b> *1	<b>M9NA</b> *1	○	○	●	○	—	○	
				3-wire (PNP)				<b>M9PAV</b> *1	<b>M9PA</b> *1	○	○	●	○	—	○	
Water resistant (2-colour indicator)	Grommet	No	2-wire	24 V	12 V	100 V or less	<b>M9BAV</b> *1	<b>M9BA</b> *1	○	○	●	○	—	○	—	
			2-wire				<b>A96V</b>	<b>A96</b>	●	—	●	—	—	—		—
Reed auto switch	— — —	Grommet	Yes	3-wire (NPN equivalent)	24 V	12 V	100 V or less	<b>A93V</b> *2	<b>A93</b>	●	●	●	●	—	—	Relay, PLC
				2-wire				<b>A90V</b>	<b>A90</b>	●	—	●	—	—	—	

\*1 Water-resistant type auto switches can be mounted on the above models, but SMC cannot guarantee water resistance.

A water-resistant type cylinder is recommended for use in an environment which requires water resistance.

\*2 The 1 m lead wire is only applicable to the D-A93.

\* Lead wire length symbols: 0.5 m..... — (Example) M9NW 3 m..... L (Example) M9NWL  
1 m..... M (Example) M9NWM 5 m..... Z (Example) M9NWZ

\* Solid state auto switches marked with a "○" are produced upon receipt of order.

\* Auto switches are shipped together with the product but do not come assembled. (However, the auto switch mounting brackets are assembled before shipment.)

\* There are applicable auto switches other than those listed above. For details, refer to page 22.

# MB2 Series

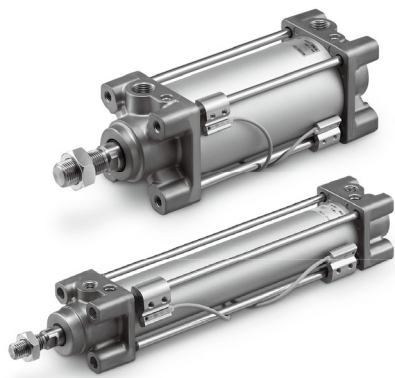

## Symbol

Double acting type

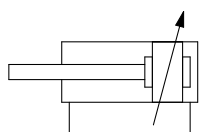

## Specifications

Bore size [mm]	32	40	50	63	80	100	125
<b>Action</b>	Double acting, Single rod						
<b>Fluid</b>	Air						
<b>Proof pressure</b>	1.5 MPa						
<b>Max. operating pressure</b>	1.0 MPa						
<b>Min. operating pressure</b>	0.05 MPa						
<b>Ambient and fluid temperatures</b>	Without auto switch: -10 to 70 °C With auto switch: -10 to 60 °C (No freezing)						
<b>Lubrication</b>	Not required (Non-lube)						
<b>Piston speed</b>	50 to 1000 mm/s						
<b>Stroke length tolerance</b>	Up to 500: $^{+2.0}_0$ , 501 to 1000: $^{+2.4}_0$ , 1001 to 1500: $^{+2.8}_0$ , 1501 to 2000: $^{+3.2}_0$ , 2001 to 2500: $^{+3.6}_0$ , 2501 to 2700: $^{+4.0}_0$						
<b>Cushion</b>	Air cushion + Rubber bumper						
<b>Mounting</b>	Basic, Axial foot, Rod flange, Head flange, Single clevis, Double clevis, Trunnion						

\* Stroke length tolerance does not include the amount of bumper change. There will be 0.1 to 1.0 mm of bumper distortion depending on the supply pressure.

## Strokes

Bore size [mm]	Standard stroke		Max. manufacturable stroke
	Stroke range ①	Stroke range ②	
<b>32</b>	50, 75, 100, 125, 150, 175, 200, 250, 300, 350, 400, 450, 500	Up to 1000	1000
<b>40</b>	50, 75, 100, 125, 150, 175, 200, 250, 300, 350, 400, 450, 500	Up to 1800	2700
<b>50</b>	50, 75, 100, 125, 150, 175, 200, 250, 300, 350, 400, 450, 500, 600		
<b>63</b>	50, 75, 100, 125, 150, 175, 200, 250, 300, 350, 400, 450, 500, 600		
<b>80</b>	50, 75, 100, 125, 150, 175, 200, 250, 300, 350, 400, 450, 500, 600, 700, 800		
<b>100</b>	50, 75, 100, 125, 150, 175, 200, 250, 300, 350, 400, 450, 500, 600, 700, 800		
<b>125</b>	50, 75, 100, 125, 150, 175, 200, 250, 300, 350, 400, 450, 500, 600, 700, 800, 900, 1000	Up to 2000	

\* Applicable strokes should be confirmed according to the usage. For details, refer to the "Air Cylinders Model Selection" in the **catalogue on [www.smc.eu](http://www.smc.eu)**. In addition, products that exceed the stroke range ① might not be able to fulfill the specifications due to deflection, etc.

\* The manufacturing of intermediate strokes is possible. (Spacers are not used.)

\* Strokes exceeding the stroke range ② are available as a special order.

\* When using a rod boot, a stroke range of up to 1000 mm is available. Strokes over 1000 mm are available as a special order.

\* Using a stroke of a length which is smaller than the effective cushion length may result in reduced air cushion performance.

## Ordering Example of Cylinder Assembly

### Cylinder model: MDB2D32-50-NW-M9BW

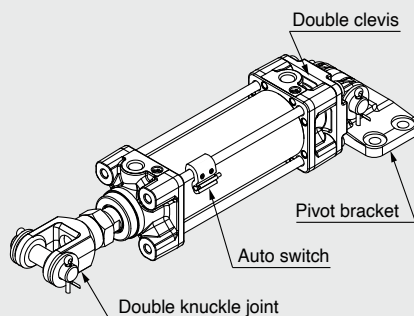

**Mounting D: Double clevis**  
**Pivot bracket N: Yes**  
**Rod end bracket W: Double knuckle joint**  
**Auto switch D-M9BW: 2 pcs.**

\* Mounting brackets (excluding the trunnion), pivot brackets, rod end brackets (excluding the rod end nut), and auto switch are shipped together with the product.

## Air Cushion Stroke

Bore size [mm]	Effective cushion length [mm]
<b>32</b>	17
<b>40</b>	17
<b>50</b>	17
<b>63</b>	17
<b>80</b>	26
<b>100</b>	26
<b>125</b>	26

Refer to pages 20 to 26 for cylinders with auto switches.

- Auto Switch Proper Mounting Position (Detection at stroke end) and Mounting Height
- Minimum Stroke for Auto Switch Mounting
- Auto Switch Mounting Brackets/Part Nos.
- Operating Range

## Mounting Brackets/Order Nos.

Bore size [mm]	32	40	50	63	80	100	125
Axial foot*1	MB-L03	MB-L04	MB-L05	MB-L06	MB-L08	MB-L10	MB-L12
Flange	MB-F03	MB-F04	MB-F05	MB-F06	MB-F08	MB-F10	MB-F12
Single clevis	MB-C03	MB-C04	MB-C05	MB-C06	MB-C08	MB-C10	MB-C12
Double clevis	MB-D03	MB-D04	MB-D05	MB-D06	MB-D08	MB-D10	MB-D12

- \*1 When ordering axial foot brackets, order 2 pieces per cylinder.
- \* It is possible to order the mounting brackets separately. Refer to each bore size in the table above for part numbers.
- \* Parts included with each type of mounting bracket are as follows.  
Axial foot, Flange, Single clevis: Body mounting bolt  
Double clevis: Body mounting bolt, Clevis pin, Flat washer (2 pcs.), Split pin (2 pcs.)  
R Refer to page 12.

## Mounting Brackets, Accessories/Material, Surface Treatment

Segment	Description	Material	Surface treatment (Ø 32 to Ø 100)	Surface treatment (Ø 125)
Mounting brackets	Axial foot	Rolled steel	Zinc chromating	Metallic silver colour painting
	Flange	Cast iron	Metallic silver colour painting	Metallic silver colour painting
	Single clevis	Cast iron	Metallic silver colour painting after zinc plating	Metallic silver colour painting
	Double clevis	Cast iron	Metallic silver colour painting after zinc plating	Metallic silver colour painting
	Trunnion	Cast iron	Metallic silver colour painting after zinc chromating	Metallic silver colour painting
Accessories	Double clevis pivot bracket	Cast iron	Metallic silver colour painting after zinc chromating	Metallic silver colour painting
	Trunnion pivot bracket	Cast iron	Metallic silver colour painting after zinc chromating	Metallic silver colour painting
	Single knuckle joint	Free-cutting steel	Zinc chromating	Electroless nickel plating
	Double knuckle joint	Cast iron	Metallic silver colour painting	Metallic silver colour painting
	Rod end	Carbon steel	Zinc plating	Zinc plating
	Knuckle joint pin	Carbon steel	—	—
	Clevis pin	Carbon steel	—	—
Rod end nut	Rolled steel	Zinc chromating	Zinc chromating	

- \* Refer to pages 11 and 12 for accessory dimensions.

## Theoretical Output

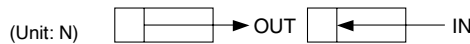

Bore size [mm]	Rod size [mm]	Operating direction	Piston area [mm <sup>2</sup> ]	Operating pressure [MPa]								
				0.2	0.3	0.4	0.5	0.6	0.7	0.8	0.9	1.0
32	12	OUT	804	161	241	322	402	482	563	643	724	804
		IN	691	138	207	276	346	415	484	553	622	691
40	16	OUT	1257	251	377	503	629	754	880	1006	1131	1257
		IN	1056	211	317	422	528	634	739	845	950	1056
50	20	OUT	1963	393	589	785	982	1178	1374	1570	1767	1963
		IN	1649	330	495	660	825	989	1154	1319	1484	1649
63	20	OUT	3117	623	935	1247	1559	1870	2182	2494	2805	3117
		IN	2803	561	841	1121	1402	1682	1962	2242	2523	2803
80	25	OUT	5027	1005	1508	2011	2514	3016	3519	4022	4524	5027
		IN	4536	907	1361	1814	2268	2722	3175	3629	4082	4536
100	30	OUT	7854	1571	2356	3142	3927	4712	5498	6283	7069	7854
		IN	7147	1429	2144	2859	3574	4288	5003	5718	6432	7147
125	32	OUT	12272	2454	3682	4909	6136	7363	8590	9818	11045	12272
		IN	11468	2294	3440	4588	5734	6881	8028	9174	10321	11468

- \* Theoretical output [N] = Pressure [MPa] x Piston area [mm<sup>2</sup>]

## Weight

Bore size [mm]		32	40	50	63	80	100	125
Basic weight	Basic	0.42	0.57	0.97	1.13	2.19	3.11	5.09
	Axial foot	0.54	0.71	1.19	1.41	2.69	3.77	7.17
	Flange	0.71	0.94	1.42	1.92	3.64	4.94	9.25
	Single clevis	0.67	0.80	1.31	1.76	3.30	4.69	7.66
	Double clevis	0.68	0.84	1.40	1.92	3.59	4.96	7.86
	Trunnion	0.71	0.93	1.45	1.93	3.74	4.80	8.07
Additional weight per 50 mm of stroke	All mounting brackets	0.11	0.16	0.26	0.27	0.42	0.56	0.71
Accessories	With auto switch (Built-in magnet)	0.01	0.01	0.01	0.02	0.02	0.03	0.06
	Clevis pivot bracket	0.19	0.19	0.41	0.41	1.13	1.13	2.37
	Trunnion pivot bracket (1 pc.)	0.09	0.21	0.21	0.4	0.4	0.82	1.68
	Single knuckle joint	0.15	0.23	0.26	0.26	0.6	0.83	1.08
	Double knuckle joint (with pin)	0.22	0.37	0.43	0.43	0.87	1.27	1.58
	Rod end	0.07	0.16	0.3	0.3	0.49	0.67	1.12

## Rod Boot Material

Symbol	Material	Max. ambient temp.
J	Nylon tarpaulin	70 °C
K	Heat-resistant tarpaulin	110 °C*1

- \*1 Max. ambient temperature for rod boot itself
- \* The rod boot replacement part numbers are listed in the "Maintenance Parts List." Refer to the catalogue on [www.smc.eu](http://www.smc.eu).

## Allowable Kinetic Energy

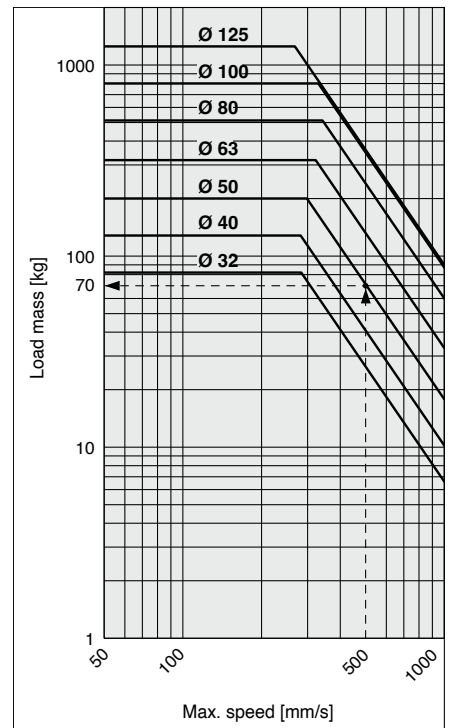

Example) Load limit at the rod end when an air cylinder with a bore size of Ø 50 is actuated at 500 mm/s  
Extend upward from 500 mm/s on the horizontal axis of the graph to the intersection point with the line for a 50 mm bore size, and then extend leftward from this point to find the load of 70 kg.

[J]

Bore size [mm]	32	40	50	63	80	100	125
Allowable kinetic energy	3.3	5.1	8.9	16.5	30.0	43.5	45.0

Calculation example)

- MB2B32-100** (Basic, Ø 32, 100 mm stroke)
- Basic weight ..... 0.42 (Basic, Ø 32)
  - Additional weight ..... 0.11/50 mm stroke
  - Cylinder stroke ..... 100 mm stroke

$$0.42 + 0.11 \times 100/50 = 0.64 \text{ kg}$$

# MB2 Series

## Replacement Parts

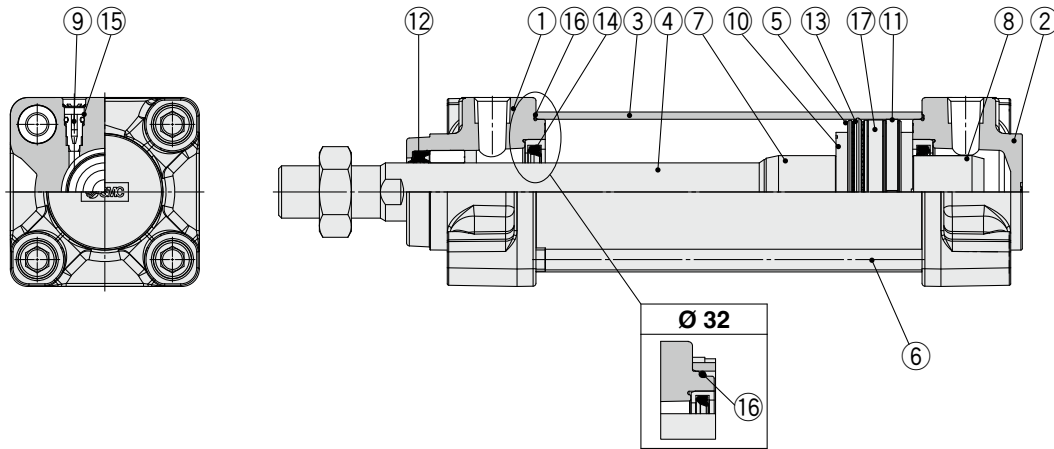

### Component Parts

No.	Description
1	Rod cover
2	Head cover
3	Cylinder tube
4	Piston rod
5	Piston
6	Tie-rod
7	Cushion ring A
8	Cushion ring B
9	Cushion valve
10	Bumper
11	Wear ring
12	Rod seal
13	Piston seal
14	Cushion seal
15	Cushion valve seal
16	Cylinder tube gasket
17	Magnet

### Replacement Parts/Seal Kit

Bore size [mm]	Kit no.	Contents
32	MB2-32-PS	Set of the nos. ⑩ (2 pcs.), ⑪ (1 pc.), ⑫ (1 pc.), ⑬ (1 pc.), ⑭ (2 pcs.), ⑯ (2 pcs.)
40	MB2-40-PS	
50	MB2-50-PS	
63	MB2-63-PS	
80	MB2-80-PS	
100	MB2-100-PS	
125	MB2-125-PS	

- \* Seal kits can be ordered using the seal kit part number corresponding to each bore size.
- \* Trunnion type should not be disassembled.
- \* The seal kit includes a grease pack (10 g for Ø 32 to Ø 50, 20 g for Ø 80, 30 g for Ø 100 and Ø 125).  
Order with the following part number when only the grease pack is needed.  
**Grease pack part number: GR-S-010 (10 g), GR-S-020 (20 g)**
- \* Refer to the operation manual for seal replacement instructions.



**Standard**

**Basic: (M□D□B2B)**

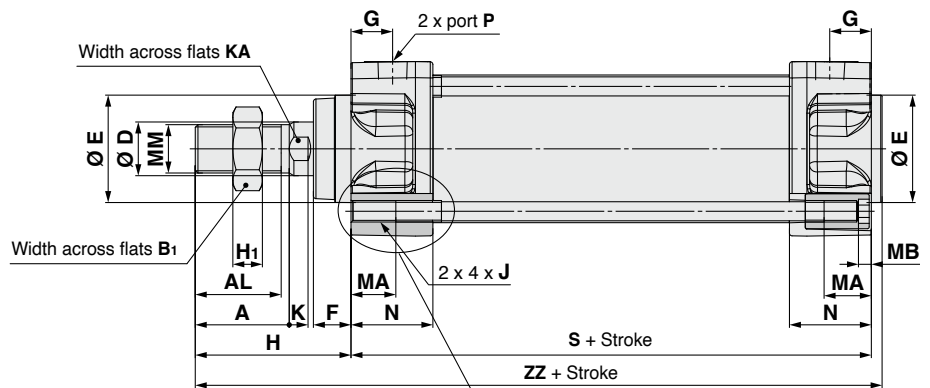
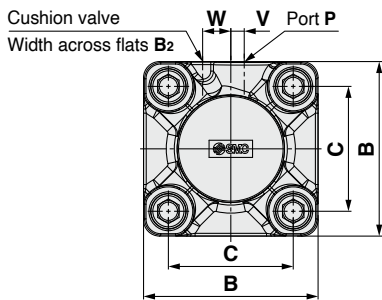

**With rod boot**

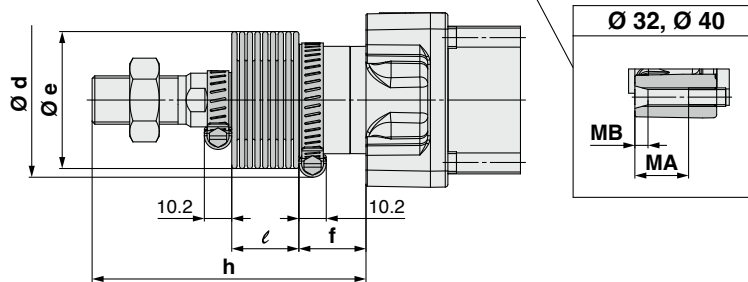

[mm]

Bore size [mm]	A	AL	B	B <sub>1</sub>	B <sub>2</sub>	C	D	E	F	G	H	H <sub>1</sub>	J	K	KA	MA	MB	MM	N	P	S	V	W	ZZ
32	22	19.5	46	17	2	32.5	12	30	13	13	47	6	M6 x 1	6	10	16	4	M10 x 1.25	27	1/8	84	4	7	135
40	30	27	52	22	2	38	16	35	13	14	51	8	M6 x 1	6	14	16	4	M14 x 1.5	27	1/4	84	4	10	139
50	35	32	65	27	2	46.5	20	40	14	15.5	58	11	M8 x 1.25	7	18	16	5	M18 x 1.5	31.5	1/4	94	5	10.5	156
63	35	32	75	27	2	56.5	20	45	14	16.5	58	11	M8 x 1.25	7	18	16	5	M18 x 1.5	31.5	3/8	94	9	12	156
80	40	37	95	32	3	72	25	45	20	19	72	13	M10 x 1.5	10	22	16	5	M22 x 1.5	38	3/8	114	11.5	12	190
100	40	37	114	41	3	89	30	55	20	19	72	16	M10 x 1.5	10	26	16	5	M26 x 1.5	38	1/2	114	17	13	190
125	54	50	136	41	4	110	32	60	27	19	97	16	M12 x 1.75	13	27	20	6	M27 x 2	38	1/2	120	17	15	223

**With Rod Boot**

[mm]

Bore size [mm]	d	e	f	l											
				1 to 50	51 to 100	101 to 150	151 to 200	201 to 300	301 to 400	401 to 500	501 to 600	601 to 700	701 to 800	801 to 900	901 to 1000
32	54	36	23	12.5	25	37.5	50	75	100	125	150	175	200	225	250
40	56	41	23	12.5	25	37.5	50	75	100	125	150	175	200	225	250
50	64	51	25	12.5	25	37.5	50	75	100	125	150	175	200	225	250
63	64	51	25	12.5	25	37.5	50	75	100	125	150	175	200	225	250
80	68	56	29	12.5	25	37.5	50	75	100	125	150	175	200	225	250
100	76	61	29	12.5	25	37.5	50	75	100	125	150	175	200	225	250
125	82	75	27	10	20	30	40	60	80	100	120	140	160	180	200

[mm]

Bore size [mm]	h											
	1 to 50	51 to 100	101 to 150	151 to 200	201 to 300	301 to 400	401 to 500	501 to 600	601 to 700	701 to 800	801 to 900	901 to 1000
32	73	86	98	111	136	161	186	211	236	261	286	311
40	81	94	106	119	144	169	194	219	244	269	294	319
50	89	102	114	127	152	177	202	227	252	277	302	327
63	89	102	114	127	152	177	202	227	252	277	302	327
80	101	114	126	139	164	189	214	239	264	289	314	339
100	101	114	126	139	164	189	214	239	264	289	314	339
125	120	130	140	150	170	190	210	230	250	270	290	310

# MB2 Series

## Standard/With Mounting Bracket

\* Refer to Basic (page 8) for other dimensions.

### Axial foot: (MDB2L)

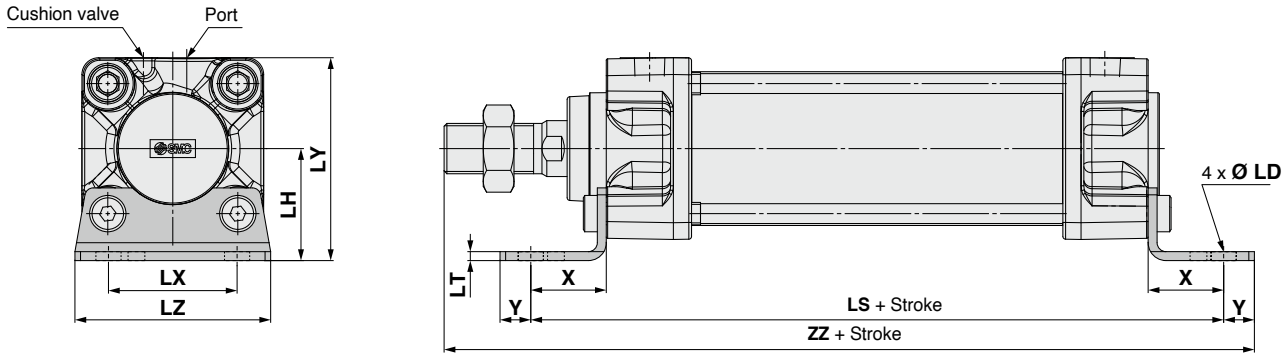

Bore size [mm]	LD	LH	LS	LT	LX	LY	LZ	X	Y	ZZ
32	7	30	128	3.2	32	53	50	22	9	162
40	9	33	132	3.2	38	59	55	24	11	170
50	9	40	148	3.2	46	72.5	70	27	11	190
63	12	45	148	3.6	56	82.5	80	27	14	193

Bore size [mm]	LD	LH	LS	LT	LX	LY	LZ	X	Y	ZZ
80	12	55	174	4.5	72	102.5	100	30	14	230
100	14	65	178	4.5	89	122	120	32	16	234
125	14	81	210	8	90	149	136	45	20	282

### Rod flange: (MDB2F)

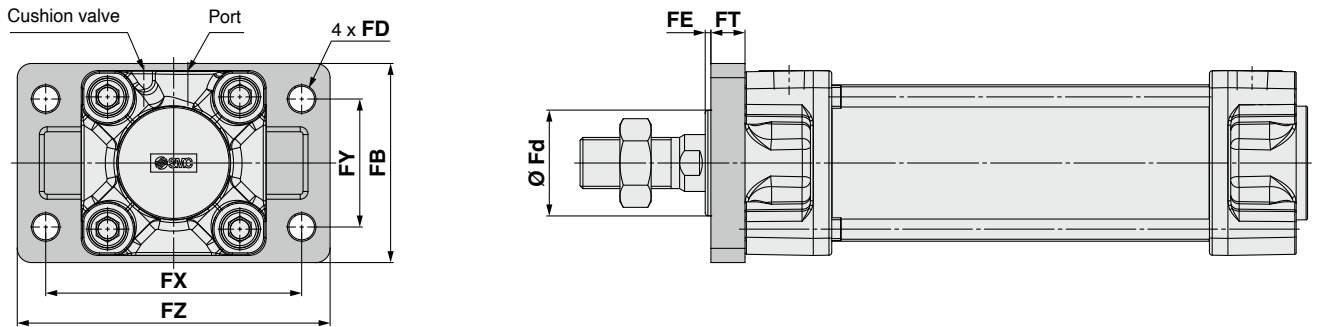

Bore size [mm]	Fd	FB	FD	FE	FT	FX	FY	FZ
32	28	50	7	3	10	64	32	79
40	32	55	9	3	10	72	36	90
50	38	70	9	2	12	90	45	110
63	39	80	9	2	12	100	50	120

Bore size [mm]	Fd	FB	FD	FE	FT	FX	FY	FZ
80	44	100	12	4	16	126	63	153
100	52	120	14	4	16	150	75	178
125	57	138	14	7	20	180	102	216

### Head flange: (MDB2G)

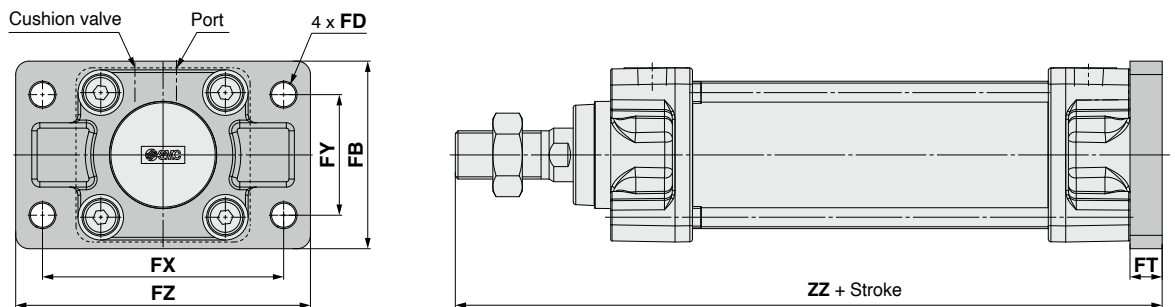

Bore size [mm]	FB	FD	FT	FX	FY	FZ	ZZ
32	50	7	10	64	32	79	141
40	55	9	10	72	36	90	145
50	70	9	12	90	45	110	164
63	80	9	12	100	50	120	164

Bore size [mm]	FB	FD	FT	FX	FY	FZ	ZZ
80	100	12	16	126	63	153	202
100	120	14	16	150	75	178	202
125	138	14	20	180	102	216	237

**Standard/With Mounting Bracket**

\* Refer to Basic (page 8) for other dimensions.

**Single clevis: (M□B2C)**

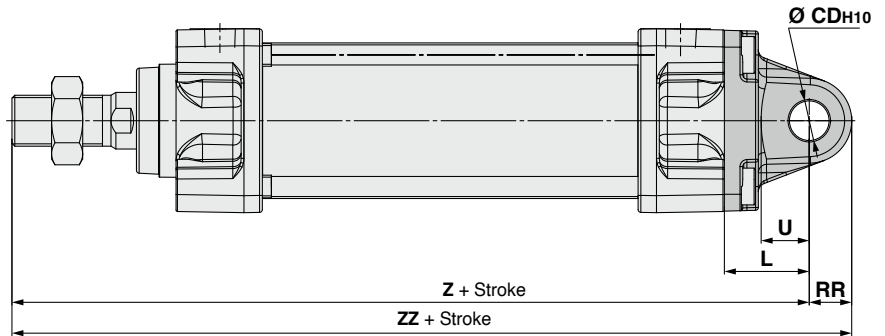
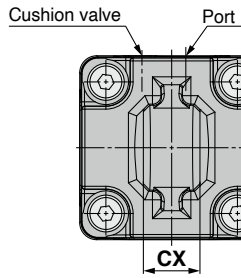

Bore size [mm]	CD <sub>H10</sub>	CX	L	RR	U	Z	ZZ
32	10 <sup>+0.058</sup> <sub>0</sub>	14 <sup>-0.1</sup> <sub>-0.3</sub>	23	10.5	13	154	164.5
40	10 <sup>+0.058</sup> <sub>0</sub>	14 <sup>-0.1</sup> <sub>-0.3</sub>	23	11	13	158	169
50	14 <sup>+0.070</sup> <sub>0</sub>	20 <sup>-0.1</sup> <sub>-0.3</sub>	30	15	17	182	197
63	14 <sup>+0.070</sup> <sub>0</sub>	20 <sup>-0.1</sup> <sub>-0.3</sub>	30	15	17	182	197

Bore size [mm]	CD <sub>H10</sub>	CX	L	RR	U	Z	ZZ
80	22 <sup>+0.084</sup> <sub>0</sub>	30 <sup>-0.1</sup> <sub>-0.3</sub>	42	23	26	228	251
100	22 <sup>+0.084</sup> <sub>0</sub>	30 <sup>-0.1</sup> <sub>-0.3</sub>	42	23	26	228	251
125	25 <sup>+0.084</sup> <sub>0</sub>	32 <sup>-0.1</sup> <sub>-0.3</sub>	50	28	30	267	295

**Double clevis: (M□B2D)**

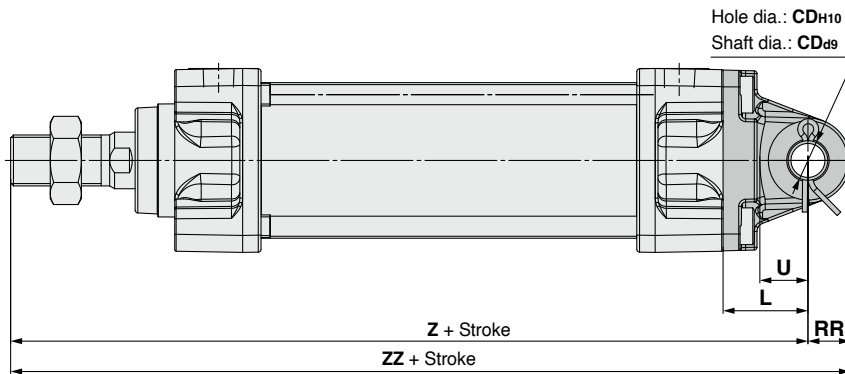
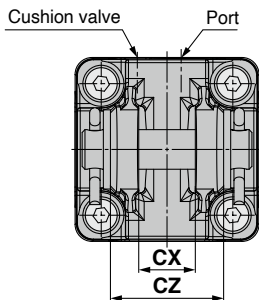

Bore size [mm]	CD <sub>H10</sub>	CD <sub>a9</sub>	CX	CZ	L	RR	U	Z	ZZ
32	10 <sup>+0.058</sup> <sub>0</sub>	10 <sup>-0.040</sup> <sub>-0.076</sub>	14 <sup>+0.3</sup> <sub>+0.1</sub>	28	23	10.5	13	154	164.5
40	10 <sup>+0.058</sup> <sub>0</sub>	10 <sup>-0.040</sup> <sub>-0.076</sub>	14 <sup>+0.3</sup> <sub>+0.1</sub>	28	23	11	13	158	169
50	14 <sup>+0.070</sup> <sub>0</sub>	14 <sup>-0.050</sup> <sub>-0.093</sub>	20 <sup>+0.3</sup> <sub>+0.1</sub>	40	30	15	17	182	197
63	14 <sup>+0.070</sup> <sub>0</sub>	14 <sup>-0.050</sup> <sub>-0.093</sub>	20 <sup>+0.3</sup> <sub>+0.1</sub>	40	30	15	17	182	197

Bore size [mm]	CD <sub>H10</sub>	CD <sub>a9</sub>	CX	CZ	L	RR	U	Z	ZZ
80	22 <sup>+0.084</sup> <sub>0</sub>	22 <sup>-0.065</sup> <sub>-0.117</sub>	30 <sup>+0.3</sup> <sub>+0.1</sub>	60	42	23	26	228	251
100	22 <sup>+0.084</sup> <sub>0</sub>	22 <sup>-0.065</sup> <sub>-0.117</sub>	30 <sup>+0.3</sup> <sub>+0.1</sub>	60	42	23	26	228	251
125	25 <sup>+0.084</sup> <sub>0</sub>	25 <sup>-0.065</sup> <sub>-0.117</sub>	32 <sup>+0.3</sup> <sub>+0.1</sub>	64	50	28	30	267	295

**Trunnion: (M□B2T)**

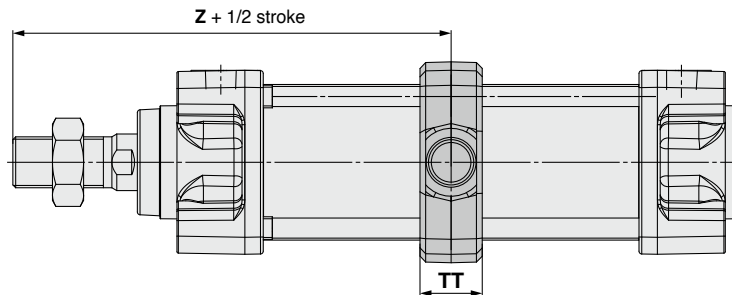
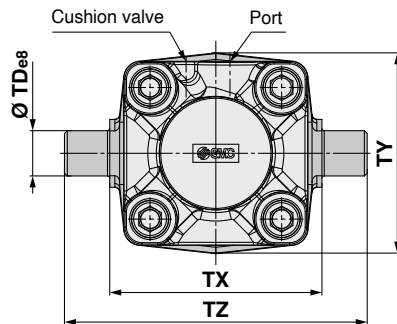

Bore size [mm]	TD <sub>a8</sub>	TT	TX	TY	TZ	Z
32	12 <sup>-0.032</sup> <sub>-0.059</sub>	17	50	49	74	89
40	16 <sup>-0.032</sup> <sub>-0.059</sub>	22	63	58	95	93
50	16 <sup>-0.032</sup> <sub>-0.059</sub>	22	75	71	107	105
63	20 <sup>-0.040</sup> <sub>-0.073</sub>	28	90	87	130	105

Bore size [mm]	TD <sub>a8</sub>	TT	TX	TY	TZ	Z
80	20 <sup>-0.040</sup> <sub>-0.073</sub>	34	110	110	150	129
100	25 <sup>-0.040</sup> <sub>-0.073</sub>	40	132	136	182	129
125	25 <sup>-0.040</sup> <sub>-0.073</sub>	50	160	160	210	157

# MB2 Series

## Pivot Bracket/Trunnion and Double Clevis Pivot Bracket

### Trunnion pivot bracket for the M □ B2T

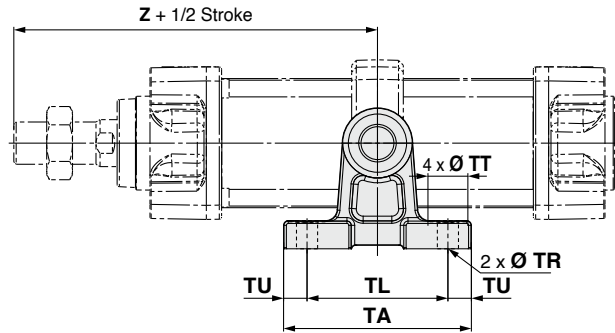
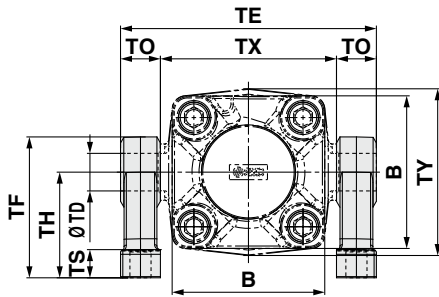

[mm]

Bore size [mm]	Part no.	B	TA	TL	TU	TC	TX	TE	TO	TR	TT	TS	TH	TF	Z	TD <sub>H10</sub>
32	MB-S03	46	62	45	8.5	62	50	74	12	7	13	10	35	47	89	12 <sup>+0.070</sup> <sub>0</sub>
40	MB-S04	52	80	60	10	80	63	97	17	9	17	12	45	60	93	16 <sup>+0.070</sup> <sub>0</sub>
50		65	80	60	10	92	75	109	17	9	17	12	45	60	105	16 <sup>+0.070</sup> <sub>0</sub>
63	MB-S06	75	100	70	15	110	90	130	20	11	22	14	60	80	105	20 <sup>+0.084</sup> <sub>0</sub>
80		95	100	70	15	130	110	150	20	11	22	14	60	80	129	20 <sup>+0.084</sup> <sub>0</sub>
100	MB-S10	114	120	90	15	158	132	184	26	13.5	24	17	75	100	129	25 <sup>+0.084</sup> <sub>0</sub>
125	MB-S12	136	142	105	18.5	186	160	212	26	13.5	24	25	85	115	157	25 <sup>+0.084</sup> <sub>0</sub>

### Double clevis pivot bracket for the M □ B2D

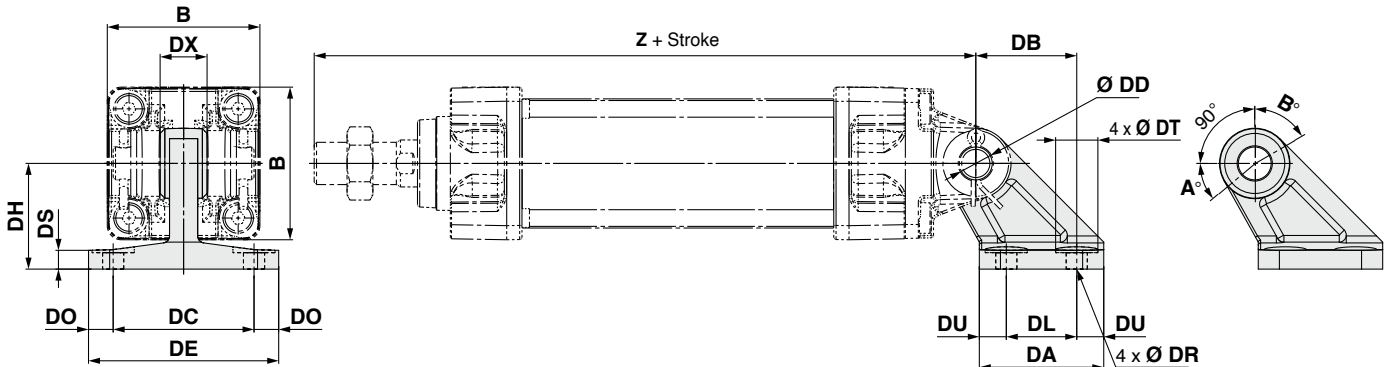

[mm]

Bore size [mm]	Part no.	B	DA	DB	DL	DU	DC	DX	DE	DO	DR	DT	DS	DH	Z	DD <sub>H10</sub>
32	MB-B03	46	42	32	22	10	44	14	62	9	6.6	15	7	33	154	10 <sup>+0.058</sup> <sub>0</sub>
40		52	42	32	22	10	44	14	62	9	6.6	15	7	33	158	10 <sup>+0.058</sup> <sub>0</sub>
50	MB-B05	65	53	43	30	11.5	60	20	81	10.5	9	18	8	45	182	14 <sup>+0.070</sup> <sub>0</sub>
63		75	53	43	30	11.5	60	20	81	10.5	9	18	8	45	182	14 <sup>+0.070</sup> <sub>0</sub>
80	MB-B08	95	73	64	45	14	86	30	111	12.5	11	22	10	65	228	22 <sup>+0.084</sup> <sub>0</sub>
100		114	73	64	45	14	86	30	111	12.5	11	22	10	65	228	22 <sup>+0.084</sup> <sub>0</sub>
125	MB-B12	136	90	78	60	15	110	32	136	13	13.5	24	14	75	267	25 <sup>+0.084</sup> <sub>0</sub>

### Rotating Angle

Bore size [mm]	A°	B°	A° + B° + 90°
32, 40	25°	45°	160°
50, 63	40°	60°	190°
80, 100	30°	55°	175°
125	30°	50°	170°

# MB2 Series Rod End Bracket Dimensions

## Single Knuckle Joint

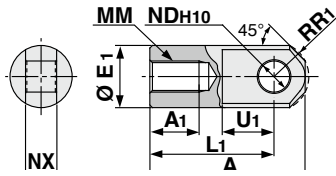

Bore size [mm]	Part no.	A	A <sub>1</sub>	E <sub>1</sub>	L <sub>1</sub>	MM	R <sub>1</sub>	U <sub>1</sub>	ND <sub>H10</sub>	NX
32	I-03M	40	14	20	30	M10 x 1.25	12	16	10 <sup>+0.058</sup> <sub>0</sub>	14 <sup>-0.10</sup> <sub>-0.30</sub>
40	I-04M	50	19	22	40	M14 x 1.5	12.5	19	10 <sup>+0.058</sup> <sub>0</sub>	14 <sup>-0.10</sup> <sub>-0.30</sub>
50, 63	I-05M	64	24	28	50	M18 x 1.5	16.5	24	14 <sup>+0.070</sup> <sub>0</sub>	20 <sup>-0.10</sup> <sub>-0.30</sub>
80	I-08M	80	26	40	60	M22 x 1.5	23.5	34	22 <sup>+0.084</sup> <sub>0</sub>	30 <sup>-0.10</sup> <sub>-0.30</sub>
100	I-10M	80	26	40	60	M26 x 1.5	23.5	34	22 <sup>+0.084</sup> <sub>0</sub>	30 <sup>-0.10</sup> <sub>-0.30</sub>
125	I-12M	119	36	46	92	M27 x 2	28.5	34	25 <sup>+0.084</sup> <sub>0</sub>	32 <sup>-0.10</sup> <sub>-0.30</sub>

## Double Knuckle Joint

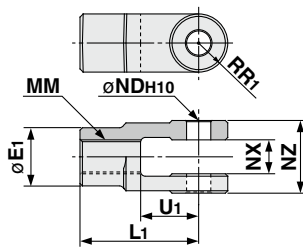

Bore size [mm]	Part no.	E <sub>1</sub>	L <sub>1</sub>	MM	R <sub>1</sub>	U <sub>1</sub>	ND <sub>H10</sub>	NX	NZ
32	Y-03M*1	20	30	M10 x 1.25	10	16	10 <sup>+0.058</sup> <sub>0</sub>	14 <sup>+0.30</sup> <sub>+0.10</sub>	28 <sup>-0.10</sup> <sub>-0.30</sub>
40	Y-04M*1	22	40	M14 x 1.5	11	19	10 <sup>+0.058</sup> <sub>0</sub>	14 <sup>+0.30</sup> <sub>+0.10</sub>	28 <sup>-0.10</sup> <sub>-0.30</sub>
50, 63	Y-05M*1	28	50	M18 x 1.5	14	24	14 <sup>+0.070</sup> <sub>0</sub>	20 <sup>+0.30</sup> <sub>+0.10</sub>	40 <sup>-0.10</sup> <sub>-0.30</sub>
80	Y-08M*1	40	65	M22 x 1.5	20	34	22 <sup>+0.084</sup> <sub>0</sub>	30 <sup>+0.30</sup> <sub>+0.10</sub>	60 <sup>-0.10</sup> <sub>-0.30</sub>
100	Y-10M*1	40	65	M26 x 1.5	20	34	22 <sup>+0.084</sup> <sub>0</sub>	30 <sup>+0.30</sup> <sub>+0.10</sub>	60 <sup>-0.10</sup> <sub>-0.30</sub>
125	Y-12M*2	46	100	M27 x 2	27	42	25 <sup>+0.084</sup> <sub>0</sub>	32 <sup>+0.30</sup> <sub>+0.10</sub>	64 <sup>-0.10</sup> <sub>-0.30</sub>

\*1 A knuckle joint pin, 2 split pins, and 2 flat washers are included.  
\*2 A knuckle joint pin and 2 split pins are included.

## Knuckle Joint Pin/Clevis Pin

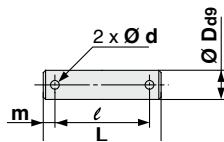

Bore size [mm]	Part no.	D <sub>ø9</sub>	L	ℓ	m	d (Drill through)	Split pin
32, 40	CD-M03*1	10 <sup>-0.040</sup> <sub>-0.076</sub>	44	36	4	3	Ø 3 x 18 ℓ
50, 63	CD-M05*1	14 <sup>-0.050</sup> <sub>-0.095</sub>	60	51	4.5	4	Ø 4 x 25 ℓ
80, 100	CD-M08*1	22 <sup>-0.065</sup> <sub>-0.117</sub>	82	72	5	4	Ø 4 x 35 ℓ
125	IY-12*2	25 <sup>-0.065</sup> <sub>-0.117</sub>	79.5	69.5	5	4	Ø 4 x 40 ℓ

\*1 2 split pins and 2 flat washers are included.  
\*2 2 split pins are included.

## Rod End

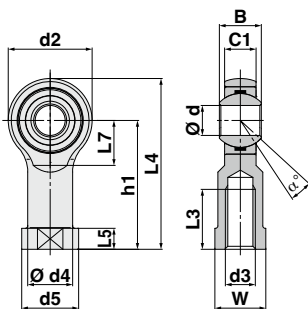

Applicable bore size	Model	d <sub>H7</sub>	d <sub>3</sub>	B <sup>0-0.12</sup>	C1	d2	d4	d5	h1	L <sub>3min</sub>	L4	L5	L7	W	α°	Allowable radial static load [kN]
32	KJ10D	10	M10 x 1.25	14	10.5	28	15	19	43	20	57	6.5	15	17	13	14
40	KJ14D	14	M14 x 1.5	19	13.5	36	20	25	57	25	75	8	19	22	15	36
50, 63	KJ18D	18	M18 x 1.5	23	16.5	46	25	31	71	32	94	10	25	27	15	51
80	KJ22D	22	M22 x 1.5	28	20	54	30	37	84	37	111	12	29	32	15	75
100	KJ26D	25	M26 x 1.5	31	22	60	33.5	42	94	48	124	12	32	36	15	85
125	KJ27D	30	M27 x 2.0	37	25	70	40	50	110	51	145	15	36	41	17	108

· The KJ27D is produced upon receipt of order.  
· The allowable radial static load shows the allowable value of a single rod end. When the rod end is used for connecting to a cylinder, the allowable radial static load conforms to the cylinder specifications.  
\* Refer to the [catalogue on www.smc.eu](http://www.smc.eu) for specifications and precautions.

## Rod End Nut (Standard)

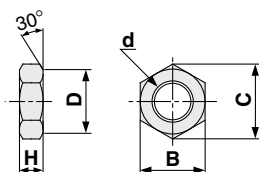

Bore size [mm]	Part no.	d	H	B	C	D
32	NT-03	M10 x 1.25	6	17	19.6	16.5
40	NT-04	M14 x 1.5	8	22	25.4	21
50, 63	NT-05	M18 x 1.5	11	27	31.2	26
80	NT-08	M22 x 1.5	13	32	37.0	31
100	NT-10	M26 x 1.5	16	41	47.3	39
125	NT-12M	M27 x 2	16	41	47.3	39

# MB2 Series

## Bracket Combinations

Bracket combination available ..... ▶ Refer to the figure below.

Bracket for cylinder	Bracket for workpiece	Single clevis	Double clevis	Single knuckle joint	Double knuckle joint	Double clevis pivot bracket
Single clevis			①	—	②	—
Double clevis		③		④	—	⑨
Single knuckle joint		—	⑤		⑥	—
Double knuckle joint		⑦	—	⑧		⑩

No.	Appearance	No.	Appearance
①	<p>Labels: Double clevis, Single clevis</p>	⑥	<p>Labels: Double knuckle joint, Single knuckle joint</p>
②	<p>Labels: Double knuckle joint, Single clevis</p>	⑦	<p>Labels: Single clevis, Double knuckle joint</p>
③	<p>Labels: Single clevis, Double clevis</p>	⑧	<p>Labels: Single knuckle joint, Double knuckle joint</p>
④	<p>Labels: Single knuckle joint, Double clevis</p>	⑨	<p>Labels: Double clevis pivot bracket, Double clevis</p>
⑤	<p>Labels: Double clevis, Single knuckle joint</p>	⑩	<p>Labels: Double clevis pivot bracket, Double knuckle joint</p>

# Air Cylinder: Standard Type Double Acting, Double Rod **MB2W Series**

RoHS

∅ 32, ∅ 40, ∅ 50, ∅ 63, ∅ 80, ∅ 100, ∅ 125

## How to Order

**MB2W L 32 [ ] - 150 [ ]**

**With auto switch** **MDB2W L 32 [ ] - 150 [ ] - M9BW [ ]**

**With auto switch**  
(Built-in magnet)

**Mounting**

<b>B</b>	Basic
<b>L</b>	Axial foot
<b>F</b>	Flange
<b>T</b>	Trunnion

\* The trunnion type is mounted before shipment.  
\* Other mounting brackets are shipped together with the product.

**Bore size**

<b>32</b>	32 mm
<b>40</b>	40 mm
<b>50</b>	50 mm
<b>63</b>	63 mm
<b>80</b>	80 mm
<b>100</b>	100 mm
<b>125</b>	125 mm

**Port thread type**

<b>-</b>	Rc
<b>TN</b>	NPT
<b>TF</b>	G

**Cylinder stroke [mm]**  
Refer to page 15 for standard strokes.

**Number of auto switches**

<b>-</b>	2
<b>S</b>	1
<b>3</b>	3
<b>n</b>	n

**Auto switch**

<b>-</b>	Without auto switch
----------	---------------------

\* For applicable auto switches, refer to the table below.

**Suffix (Rod boot)**

<b>-</b>	None
<b>J</b>	Nylon tarpaulin (One end)
<b>JJ</b>	Nylon tarpaulin (Both ends)
<b>K</b>	Heat-resistant tarpaulin (One end)
<b>KK</b>	Heat-resistant tarpaulin (Both ends)

\* For details, refer to page 15.

## Applicable Auto Switches / Refer to the catalogue on [www.smc.eu](http://www.smc.eu) for further information on auto switches.

Type	Special function	Electrical entry	Indicator light	Wiring (Output)	Load voltage		Auto switch model		Lead wire length [m]					Pre-wired connector	Applicable load			
					DC	AC	Perpendicular	In-line	0.5 (-)	1 (M)	3 (L)	5 (Z)	None (N)		IC circuit	Relay, PLC		
Solid state auto switch	----	Grommet	Yes	3-wire (NPN)	24 V	5 V, 12 V	-	<b>M9NV</b>	<b>M9N</b>	●	●	●	○	-	○	IC circuit	Relay, PLC	
				3-wire (PNP)				<b>M9PV</b>	<b>M9P</b>	●	●	●	○	-	○			
				2-wire				<b>M9BV</b>	<b>M9B</b>	●	●	●	○	-	○			
				3-wire (NPN)				<b>M9NVV</b>	<b>M9NW</b>	●	●	●	○	-	○			
	Diagnostic indication (2-colour indicator)	Grommet	Yes	3-wire (PNP)	24 V	5 V, 12 V	-	<b>M9PWV</b>	<b>M9PW</b>	●	●	●	○	-	○	IC circuit	Relay, PLC	
				2-wire				<b>M9BWV</b>	<b>M9BW</b>	●	●	●	○	-	○			
				3-wire (NPN)				<b>M9NAV</b> *1	<b>M9NA</b> *1	○	○	●	○	-	○			
				3-wire (PNP)				<b>M9PAV</b> *1	<b>M9PA</b> *1	○	○	●	○	-	○			
Water resistant (2-colour indicator)	Grommet	Yes	2-wire	24 V	12 V	-	<b>M9BAV</b> *1	<b>M9BA</b> *1	○	○	○	○	-	○	-	-		
Reed auto switch	----	Grommet	Yes	3-wire (NPN equivalent)	24 V	12 V	100 V or less	<b>A96V</b>	<b>A96</b>	●	-	●	-	-	-	IC circuit	-	
				2-wire				<b>A93V</b> *2	<b>A93</b>	●	●	●	●	-	-			-
								<b>A90V</b>	<b>A90</b>	●	-	●	-	-	-			-

\*1 Water-resistant type auto switches can be mounted on the above models, but SMC cannot guarantee water resistance. A water-resistant type cylinder is recommended for use in an environment which requires water resistance.

\*2 The 1 m lead wire is only applicable to the D-A93.

\* Lead wire length symbols: 0.5 m..... - (Example) M9NW 3 m..... L (Example) M9NWL  
1 m..... M (Example) M9NWM 5 m..... Z (Example) M9NWZ

\* Solid state auto switches marked with a "○" are produced upon receipt of order.

\* Auto switches are shipped together with the product but do not come assembled. (However, the auto switch mounting brackets are assembled before shipment.)

\* There are applicable auto switches other than those listed above. For details, refer to page 22.

# MB2W Series

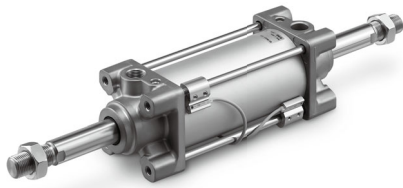

## Symbol

Double acting type, Air cushion

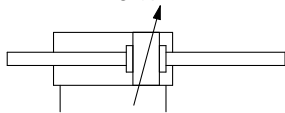

Refer to pages 20 to 26 for cylinders with auto switches.

- Auto Switch Proper Mounting Position (Detection at stroke end) and Mounting Height
- Minimum Stroke for Auto Switch Mounting
- Auto Switch Mounting Brackets/Part Nos.
- Operating Range

## Specifications

Bore size [mm]	32	40	50	63	80	100	125
<b>Action</b>	Double acting, Double rod						
<b>Fluid</b>	Air						
<b>Proof pressure</b>	1.5 MPa						
<b>Max. operating pressure</b>	1.0 MPa						
<b>Min. operating pressure</b>	0.05 MPa						
<b>Ambient and fluid temperatures</b>	Without auto switch: -10 to 70 °C (No freezing) With auto switch: -10 to 60 °C						
<b>Lubrication</b>	Not required (Non-lube)						
<b>Piston speed</b>	50 to 1000 mm/s						
<b>Stroke length tolerance</b>	Up to 500: $^{+2.0}_0$ , 501 to 1000: $^{+2.4}_0$ , 1001 to 1500: $^{+2.8}_0$ , 1501 to 2000: $^{+3.2}_0$						
<b>Cushion*1</b>	Air cushion + Rubber bumper						
<b>Mounting</b>	Basic, Axial foot, Flange, Trunnion						

\*1 Kinetic energy is identical to that of the double acting, single rod type.

\* Stroke length tolerance does not include the amount of bumper change. There will be 0.1 to 1.0 mm of bumper distortion depending on the supply pressure.

## Strokes

Bore size [mm]	Standard stroke		Max. manufacturable stroke
	Stroke range ①	Stroke range ②	
<b>32</b>	50, 75, 100, 125, 150, 175, 200, 250, 300, 350, 400, 450, 500	Up to 1000	1000
<b>40</b>	50, 75, 100, 125, 150, 175, 200, 250, 300, 350, 400, 450, 500		
<b>50</b>	50, 75, 100, 125, 150, 175, 200, 250, 300, 350, 400, 450, 500, 600	Up to 1200	1800
<b>63</b>	50, 75, 100, 125, 150, 175, 200, 250, 300, 350, 400, 450, 500, 600		
<b>80</b>	50, 75, 100, 125, 150, 175, 200, 250, 300, 350, 400, 450, 500, 600, 700, 800	Up to 1500	2000
<b>100</b>	50, 75, 100, 125, 150, 175, 200, 250, 300, 350, 400, 450, 500, 600, 700, 800		
<b>125</b>	50, 75, 100, 125, 150, 175, 200, 250, 300, 350, 400, 450, 500, 600, 700, 800, 900, 1000		

\* Applicable strokes should be confirmed according to the usage. For details, refer to the "Air Cylinders Model Selection" in the **catalogue on [www.smc.eu](http://www.smc.eu)**. In addition, products that exceed the stroke range ① might not be able to fulfill the specifications due to deflection, etc.

\* The manufacturing of intermediate strokes is possible. (Spacers are not used.)

\* Strokes exceeding the stroke range ② are available as a special order.

\* When using a rod boot, a stroke range of up to 1000 mm is available. Strokes over 1000 mm are available as a special order.

\* Using a stroke of a length which is smaller than the effective cushion length may result in reduced air cushion performance.

## Rod Boot Material

Symbol	Material	Max. ambient temp.
<b>J</b>	Nylon tarpaulin	70 °C
<b>K</b>	Heat-resistant tarpaulin	110 °C*1

\*1 Max. ambient temperature for rod boot itself

\* The rod boot replacement part numbers are listed in the "Maintenance Parts List." Refer to the **catalogue on [www.smc.eu](http://www.smc.eu)**.

## Mounting Brackets/Order Nos.

Bore size [mm]	32	40	50	63	80	100	125
Axial foot	MB-L03	MB-L04	MB-L05	MB-L06	MB-L08	MB-L10	MB-L12
Flange	MB-F03	MB-F04	MB-F05	MB-F06	MB-F08	MB-F10	MB-F12

\* It is possible to order the mounting brackets separately. Refer to each bore size in the table above for part numbers.

\* When ordering axial foot brackets, order 2 pieces per cylinder.

## Mounting Brackets, Accessories/Material, Surface Treatment

### Air Cushion Stroke

Bore size [mm]	Effective cushion length [mm]
<b>32</b>	17
<b>40</b>	17
<b>50</b>	17
<b>63</b>	17
<b>80</b>	26
<b>100</b>	26
<b>125</b>	26

Segment	Description	Material	Surface treatment (Ø 32 to Ø 100)	Surface treatment (Ø 125)
Mounting brackets	Axial foot	Rolled steel	Zinc chromating	Metallic silver colour painting
	Flange	Cast iron	Metallic silver colour painting	Metallic silver colour painting
	Trunnion	Cast iron	Metallic silver colour painting after zinc chromating	Metallic silver colour painting
Accessories	Single knuckle joint	Free-cutting steel	Zinc chromating	Electroless nickel plating
	Double knuckle joint	Cast iron	Metallic silver colour painting	Metallic silver colour painting
	Rod end	Carbon steel	Zinc plating	Zinc plating
	Knuckle joint pin	Carbon steel	—	—
	Clevis pin	Carbon steel	—	—
	Rod end nut	Rolled steel	Zinc chromating	Zinc chromating

\* Refer to pages 11 and 12 for accessory dimensions.



## Theoretical Output

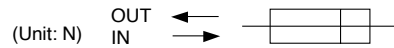

Bore size [mm]	Rod size [mm]	Operating direction	Piston area [mm <sup>2</sup> ]	Operating pressure [MPa]								
				0.2	0.3	0.4	0.5	0.6	0.7	0.8	0.9	1.0
<b>32</b>	12	IN/OUT	691	138	207	276	346	415	484	553	622	691
<b>40</b>	16	IN/OUT	1056	211	317	422	528	634	739	845	950	1056
<b>50</b>	20	IN/OUT	1649	330	495	660	825	989	1154	1319	1484	1649
<b>63</b>	20	IN/OUT	2803	561	841	1121	1402	1682	1962	2242	2523	2803
<b>80</b>	25	IN/OUT	4536	907	1361	1814	2268	2722	3175	3629	4082	4536
<b>100</b>	30	IN/OUT	7147	1429	2144	2859	3574	4288	5003	5718	6432	7147
<b>125</b>	32	IN/OUT	11468	2294	3440	4588	5734	6881	8028	9174	10321	11468

\* Theoretical output [N] = Pressure [MPa] x Piston area [mm<sup>2</sup>]

## Weight

Bore size [mm]		32	40	50	63	80	100	125
Basic weight	Basic	0.54	0.75	1.33	1.54	2.88	4.10	5.86
	Axial foot	0.66	0.89	1.55	1.82	3.38	4.76	7.94
	Flange	0.83	1.12	1.78	2.33	4.33	5.93	10.02
	Trunnion	0.83	1.11	1.81	2.34	4.43	5.79	8.84
Additional weight per 50 mm of stroke	All mounting brackets	0.15	0.24	0.37	0.38	0.61	0.82	1.02
Additional weight for magnet	With auto switch (Built-in magnet)	0.01	0.01	0.01	0.02	0.02	0.03	0.06
Accessories	Trunnion pivot bracket (1 pc.)	0.09	0.21	0.21	0.4	0.4	0.82	1.68
	Single knuckle joint	0.15	0.23	0.26	0.26	0.60	0.83	1.08
	Double knuckle joint (with pin)	0.22	0.37	0.43	0.43	0.87	1.27	1.58
	Rod end	0.07	0.16	0.3	0.3	0.49	0.67	1.12

Calculation example)

**MB2WB32-100** (Basic, Ø 32, 100 mm stroke)

- Basic weight ..... 0.54 (Basic, Ø 32)
- Additional weight ..... 0.15/50 mm stroke
- Cylinder stroke ..... 100 mm stroke

$$0.54 + 0.15 \times 100/50 = \mathbf{0.84 \text{ kg}}$$

# MB2W Series

## Replacement Parts

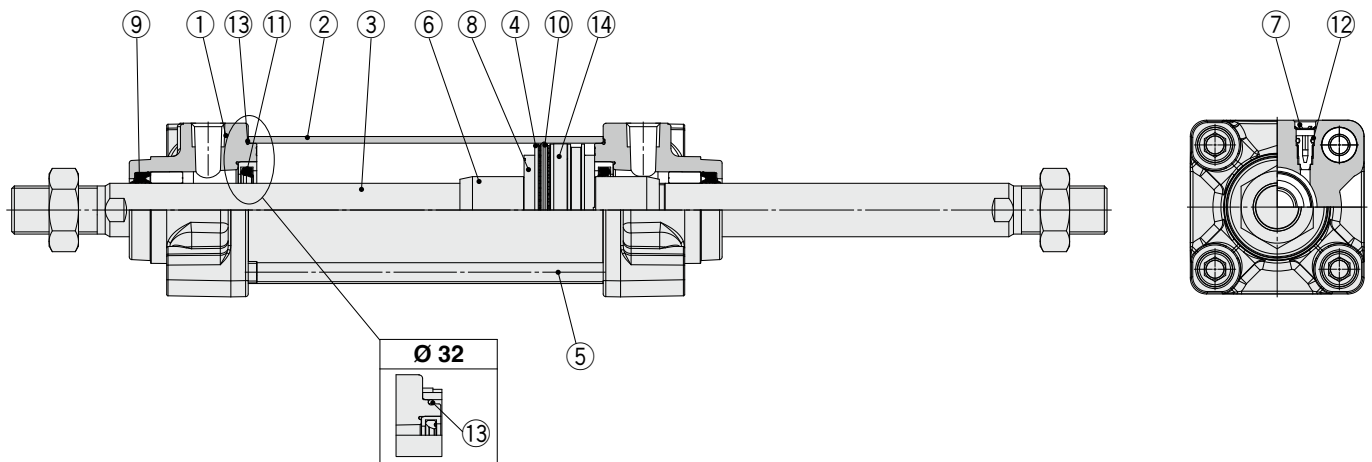

### Component Parts

No.	Description
1	Rod cover
2	Cylinder tube
3	Piston rod
4	Piston
5	Tie-rod
6	Cushion ring
7	Cushion valve
8	Bumper
9	Rod seal
10	Piston seal
11	Cushion seal
12	Cushion valve seal
13	Cylinder tube gasket
14	Magnet

### Replacement Parts/Seal Kit

Bore size [mm]	Kit no.	Contents
32	MB2W32-PS	Set of the nos. ⑧ (2 pcs.), ⑨ (2 pcs.), ⑩ (1 pc.), ⑪ (2 pcs.), ⑬ (2 pcs.)
40	MB2W40-PS	
50	MB2W50-PS	
63	MB2W63-PS	
80	MB2W80-PS	
100	MB2W100-PS	
125	MB2W125-PS	

- \* Seal kits can be ordered using the seal kit part number corresponding to each bore size.
- \* Trunnion type should not be disassembled.
- \* The seal kit includes a grease pack (10 g for Ø 32 to Ø 50, 20 g for Ø 63 and Ø 80, 30 g for Ø 100 and Ø 125).  
Order with the following part number when only the grease pack is needed.

**Grease pack part number: GR-S-010 (10 g), GR-S-020 (20 g)**

**Standard**

**Basic: (M□B2WB)**

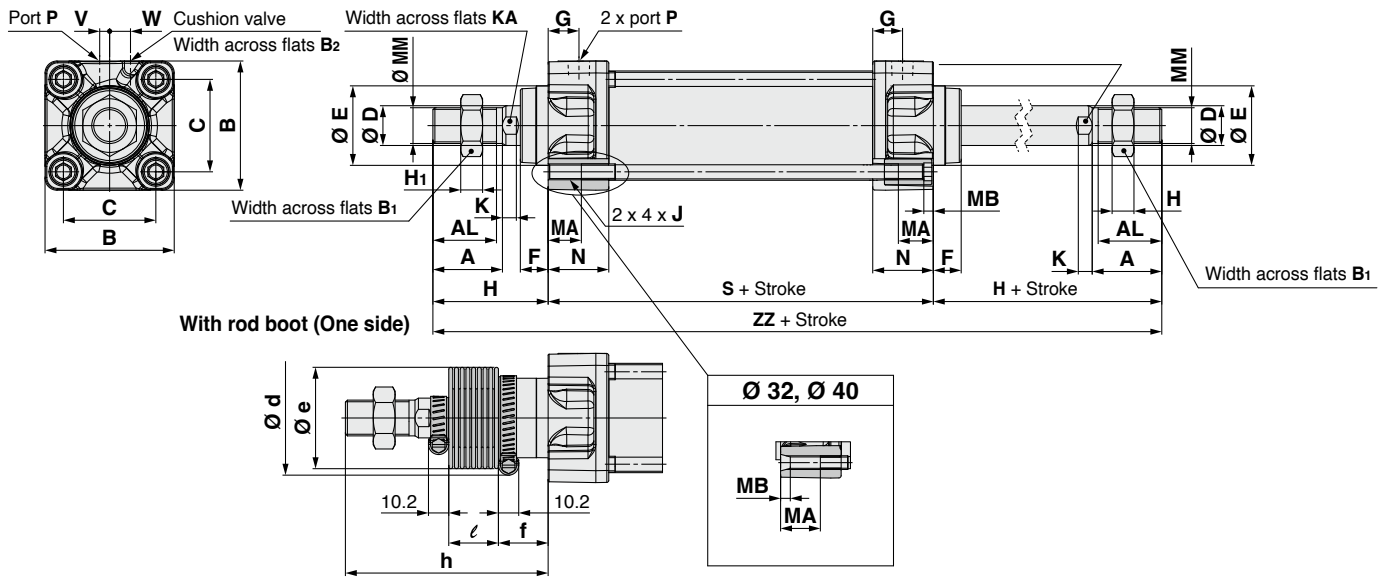

**With rod boot (Both sides)**

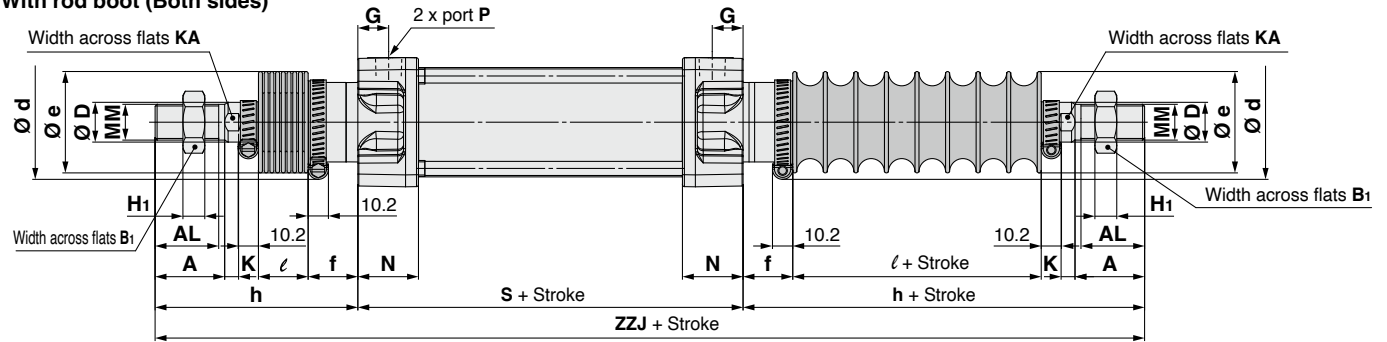

Bore size [mm]	A	AL	B	B <sub>1</sub>	B <sub>2</sub>	C	D	E	F	G	H	H <sub>1</sub>	J	K	KA	MA	MB	MM	N	P	S	V	W	ZZ
32	22	19.5	46	17	2	32.5	12	30	13	13	47	6	M6 x 1	6	10	16	4	M10 x 1.25	27	1/8	84	4	7	178
40	30	27	52	22	2	38	16	35	13	14	51	8	M6 x 1	6	14	16	4	M14 x 1.5	27	1/4	84	4	10	186
50	35	32	65	27	2	46.5	20	40	14	15.5	58	11	M8 x 1.25	7	18	16	5	M18 x 1.5	31.5	1/4	94	5	10.5	210
63	35	32	75	27	2	56.5	20	45	14	16.5	58	11	M8 x 1.25	7	18	16	5	M18 x 1.5	31.5	3/8	94	9	12	210
80	40	37	95	32	3	72	25	45	20	19	72	13	M10 x 1.5	10	22	16	5	M22 x 1.5	38	3/8	114	11.5	12	258
100	40	37	114	41	3	89	30	55	20	19	72	16	M10 x 1.5	10	26	16	5	M26 x 1.5	38	1/2	114	17	13	258
125	54	50	136	41	4	110	32	60	27	19	97	16	M12 x 1.75	13	27	20	6	M27 x 2.0	38	1/2	120	17	15	314

**With Rod Boot**

Bore size [mm]	d	e	f	ℓ																h															
				1 to 50	51 to 100	101 to 150	151 to 200	201 to 300	301 to 400	401 to 500	501 to 600	601 to 700	701 to 800	801 to 900	901 to 1000	1 to 50	51 to 100	101 to 150	151 to 200	201 to 300	301 to 400	401 to 500	501 to 600	601 to 700	701 to 800	801 to 900	901 to 1000								
32	54	36	23	12.5	25	37.5	50	75	100	125	150	175	200	225	250	73	86	98	111	136	161	186	211	236	261	286	311								
40	56	41	23	12.5	25	37.5	50	75	100	125	150	175	200	225	250	81	94	106	119	144	169	194	219	244	269	294	319								
50	64	51	25	12.5	25	37.5	50	75	100	125	150	175	200	225	250	89	102	114	127	152	177	202	227	252	277	302	327								
63	64	51	25	12.5	25	37.5	50	75	100	125	150	175	200	225	250	89	102	114	127	152	177	202	227	252	277	302	327								
80	68	56	29	12.5	25	37.5	50	75	100	125	150	175	200	225	250	101	114	126	139	164	189	214	239	264	289	314	339								
100	76	61	29	12.5	25	37.5	50	75	100	125	150	175	200	225	250	101	114	126	139	164	189	214	239	264	289	314	339								
125	82	75	27	10	20	30	40	60	80	100	120	140	160	180	200	120	130	140	150	170	190	210	230	250	270	290	310								

Bore size [mm]	ZZJ											
	1 to 50	51 to 100	101 to 150	151 to 200	201 to 300	301 to 400	401 to 500	501 to 600	601 to 700	701 to 800	801 to 900	901 to 1000
32	230	256	280	306	356	406	456	506	556	606	656	706
40	246	272	296	322	372	422	472	522	572	622	672	722
50	272	298	322	348	398	448	498	548	598	648	698	748
63	272	298	322	348	398	448	498	548	598	648	698	748
80	316	342	366	392	442	492	542	592	642	692	742	792
100	316	342	366	392	442	492	542	592	642	692	742	792
125	360	380	400	420	460	500	540	580	620	660	700	740

# MB2W Series

## Standard/With Mounting Bracket

\* Refer to Basic (page 18) for other dimensions.

### Axial foot: (M□B2WL)

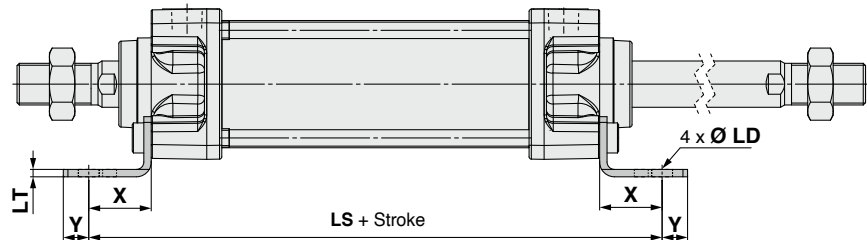
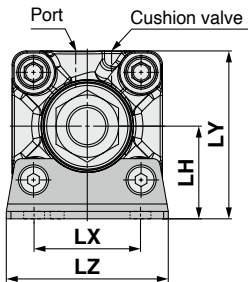

Bore size [mm]	X	Y	LD	LH	LS	LT	LX	LY	LZ
32	22	9	7	30	128	3.2	32	53	50
40	24	11	9	33	132	3.2	38	59	55
50	27	11	9	40	148	3.2	46	72.5	70
63	27	14	12	45	148	3.6	56	82.5	80
80	30	14	12	55	174	4.5	72	102.5	100
100	32	16	14	65	178	4.5	89	122	120
125	45	20	14	81	210	8	90	149	136

### Rod flange: (M□B2WF)

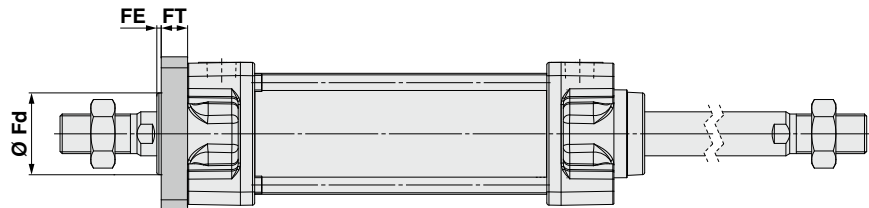
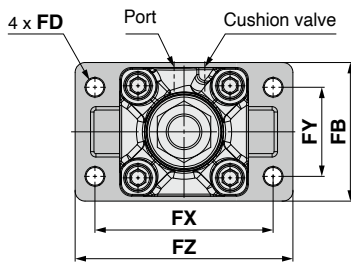

Bore size [mm]	Fd	FB	FD	FT	FX	FY	FZ
32	24.5	50	7	10	64	32	79
40	29.5	55	9	10	72	36	90
50	35.5	70	9	12	90	45	110
63	38.5	80	9	12	100	50	120
80	41	100	12	16	126	63	153
100	46	120	14	16	150	75	178
125	57	138	14	20	180	102	216

### Trunnion: (M□B2WT)

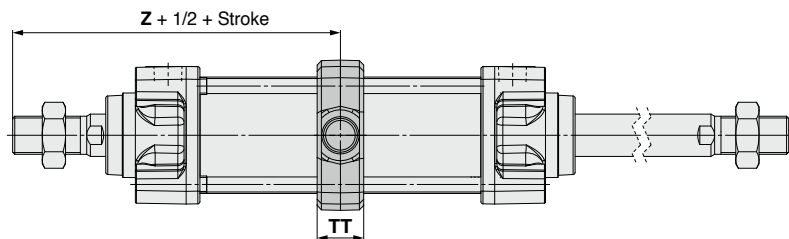
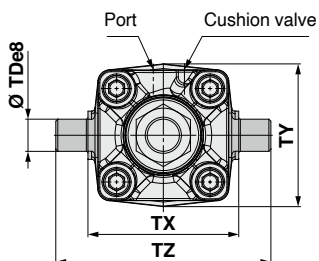

Bore size [mm]	TDe8	TT	TX	TY	TZ	Z
32	12	17	50	49	74	89
40	16	22	63	58	95	93
50	16	22	75	71	107	105
63	20	28	90	87	130	105
80	20	34	110	110	150	129
100	25	40	132	136	182	129
125	25	50	160	160	210	157

# MB2 Series

D-M9 D-A9

# Auto Switch Mounting



## Auto Switch Proper Mounting Position (Detection at stroke end) and Mounting Height

<Tie-rod mounting>

- D-M9□/M9□V
- D-M9□E/M9□EV
- D-M9□W/M9□WV
- D-M9□A/M9□AV
- D-A9□/A9□V

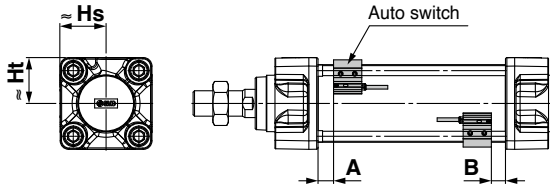

### Auto Switch Proper Mounting Position (Standard, Double rod)

[mm]

Auto switch model	D-M9□ D-M9□V D-M9□E D-M9□EV D-M9□W D-M9□WV D-M9□A D-M9□AV				D-A9□ D-A9□V	
	A	B	A	B	A	B
32	10	9.5	6	5.5		
40	9.5	9	5.5	5		
50	11	10	7	6		
63	11	10	7	6		
80	14.5	12.5	10.5	8.5		
100	14.5	12.5	10.5	8.5		
125	16	16	12	12		

### Auto Switch Mounting Height (Standard, Double rod)

[mm]

Auto switch model	D-M9□ D-M9□E D-M9□W D-M9□A D-A9□		D-A9□V		D-M9□V D-M9□EV D-M9□WV D-M9□AV	
	Hs	Ht	Hs	Ht	Hs	Ht
32	24.5	23	27.5	23	30.5	23
40	28.5	25.5	31.5	25.5	34	25.5
50	33.5	31	36	31	38.5	31
63	38.5	36	40.5	36	43	36
80	46.5	45	49	45	52	45
100	54	53.5	57	53.5	59.5	53.5
125	65.5	64.5	68.5	64.5	71	64.5

## Minimum Stroke for Auto Switch Mounting

### Mounting Brackets Except Trunnion

n: Number of auto switches [mm]

Auto switch model	Number of auto switches	∅ 32	∅ 40	∅ 50	∅ 63	∅ 80	∅ 100	∅ 125
D-M9□ D-M9□E D-M9□W D-M9□A	2 (Different surfaces, Same surface)	15						
	1	15						
D-M9□V D-M9□EV D-M9□WV D-M9□AV	2 (Different surfaces, Same surface)	10						
	1	10						
D-A9□	2 (Different surfaces, Same surface)	15						
	1	15						
D-A9□V	2 (Different surfaces, Same surface)	10						
	1	10						

\*1 When "n" is an odd number, an even number that is one larger than the odd number is to be used for the calculation.

# MB2 Series

## Minimum Stroke for Auto Switch Mounting

### Trunnion

n: Number of auto switches [mm]

Auto switch model	Number of auto switches	Ø 32	Ø 40	Ø 50	Ø 63	Ø 80	Ø 100	Ø 125
D-M9□ D-M9□E D-M9□W	2 (Different surfaces, Same surface) 1	75	80	85	90	95	105	
	n	$75 + 40 \frac{(n-4)}{2}$ (n = 4, 8, 12, 16...)*1	$80 + 40 \frac{(n-4)}{2}$ (n = 4, 8, 12, 16...)*1	$85 + 40 \frac{(n-4)}{2}$ (n = 4, 8, 12, 16...)*1	$90 + 40 \frac{(n-4)}{2}$ (n = 4, 8, 12, 16...)*1	$95 + 40 \frac{(n-4)}{2}$ (n = 4, 8, 12, 16...)*1	$105 + 40 \frac{(n-4)}{2}$ (n = 4, 8, 12, 16...)*1	
D-M9□V D-M9□EV D-M9□WV	2 (Different surfaces, Same surface) 1	50	55	60	65	70	80	
	n	$50 + 30 \frac{(n-4)}{2}$ (n = 4, 8, 12, 16...)*1	$55 + 30 \frac{(n-4)}{2}$ (n = 4, 8, 12, 16...)*1	$60 + 30 \frac{(n-4)}{2}$ (n = 4, 8, 12, 16...)*1	$65 + 30 \frac{(n-4)}{2}$ (n = 4, 8, 12, 16...)*1	$70 + 30 \frac{(n-4)}{2}$ (n = 4, 8, 12, 16...)*1	$80 + 30 \frac{(n-4)}{2}$ (n = 4, 8, 12, 16...)*1	
D-M9□A	2 (Different surfaces, Same surface) 1	80	85	90	95	100	110	
	n	$80 + 40 \frac{(n-4)}{2}$ (n = 4, 8, 12, 16...)*1	$85 + 40 \frac{(n-4)}{2}$ (n = 4, 8, 12, 16...)*1	$90 + 40 \frac{(n-4)}{2}$ (n = 4, 8, 12, 16...)*1	$95 + 40 \frac{(n-4)}{2}$ (n = 4, 8, 12, 16...)*1	$100 + 40 \frac{(n-4)}{2}$ (n = 4, 8, 12, 16...)*1	$110 + 40 \frac{(n-4)}{2}$ (n = 4, 8, 12, 16...)*1	
D-M9□AV	2 (Different surfaces, Same surface) 1	55	60	65	70	75	85	
	n	$55 + 30 \frac{(n-4)}{2}$ (n = 4, 8, 12, 16...)*1	$60 + 30 \frac{(n-4)}{2}$ (n = 4, 8, 12, 16...)*1	$65 + 30 \frac{(n-4)}{2}$ (n = 4, 8, 12, 16...)*1	$70 + 30 \frac{(n-4)}{2}$ (n = 4, 8, 12, 16...)*1	$75 + 30 \frac{(n-4)}{2}$ (n = 4, 8, 12, 16...)*1	$85 + 30 \frac{(n-4)}{2}$ (n = 4, 8, 12, 16...)*1	
D-A9□	2 (Different surfaces, Same surface) 1	70	75	80	85	95	100	
	n	$70 + 40 \frac{(n-4)}{2}$ (n = 4, 8, 12, 16...)*1	$75 + 40 \frac{(n-4)}{2}$ (n = 4, 8, 12, 16...)*1	$80 + 40 \frac{(n-4)}{2}$ (n = 4, 8, 12, 16...)*1	$85 + 40 \frac{(n-4)}{2}$ (n = 4, 8, 12, 16...)*1	$95 + 40 \frac{(n-4)}{2}$ (n = 4, 8, 12, 16...)*1	$100 + 40 \frac{(n-4)}{2}$ (n = 4, 8, 12, 16...)*1	
D-A9□V	2 (Different surfaces, Same surface) 1	45	50	55	60	70	75	
	n	$45 + 30 \frac{(n-4)}{2}$ (n = 4, 8, 12, 16...)*1	$50 + 30 \frac{(n-4)}{2}$ (n = 4, 8, 12, 16...)*1	$55 + 30 \frac{(n-4)}{2}$ (n = 4, 8, 12, 16...)*1	$60 + 30 \frac{(n-4)}{2}$ (n = 4, 8, 12, 16...)*1	$70 + 30 \frac{(n-4)}{2}$ (n = 4, 8, 12, 16...)*1	$75 + 30 \frac{(n-4)}{2}$ (n = 4, 8, 12, 16...)*1	

\*1 When "n" is an odd number, a multiple of 4 that is larger than the odd number is to be used for the calculation.

## Auto Switch Mounting Brackets/Part Nos.

Auto switch model	Bore size [mm]						
	Ø 32	Ø 40	Ø 50	Ø 63	Ø 80	Ø 100	Ø 125
D-M9□/M9□V D-M9□E/M9□EV D-M9□W/M9□WV D-M9□A/M9□AV D-A9□/A9□V	BMB5-032	BMB5-032	BA7-040	BA7-040	BA7-063	BA7-063	BA7-080

### [Stainless Steel Mounting Screw]

The following stainless steel mounting screw kit (including set screws) is available. Use it in accordance with the operating environment. (Since the auto switch mounting bracket is not included, order it separately.)

BBA1: For D-M9/A9 types

- \* For details on the BBA1, refer to the "How to Mount and Move the Auto Switch" section in the [catalogue on www.smc.eu](http://www.smc.eu).
- \* When using the D-M9□A(V), do not use the steel set screws which are included with the auto switch mounting brackets above (BMB5-032, BA7-□□□). Order a stainless steel screw kit (BBA1) separately before use.

## Operating Range

Auto switch model	Bore size [mm]						
	32	40	50	63	80	100	125
D-M9□/M9□V D-M9□E/M9□EV D-M9□W/M9□WV D-M9□A/M9□AV	4	4.5	4.5	4.5	5	6	7
D-A9□/A9□V	7	7.5	8.5	9.5	9.5	10.5	12

\* Values which include hysteresis are for reference purposes only. They are not a guarantee (assuming approx. ±30% dispersion) and may change substantially depending on the ambient environment.

### <Mounting example for Ø 32, D-M9B>

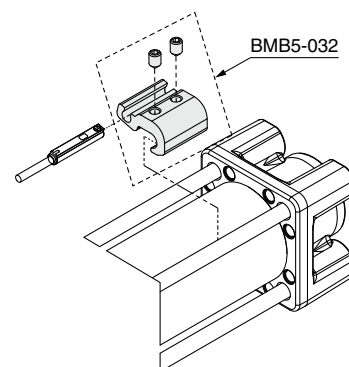

# MB2 Series

D-Y5/Y6/Y7/F5/J5/G39/K39/P3DWA/P4DW

D-A3/A44/A5/A6/Z7/Z80

# Auto Switch Mounting



Other than the applicable auto switches listed in “How to Order,” the following auto switches are also mountable. Refer to the catalogue on [www.smc.eu](http://www.smc.eu) for detailed specifications.

Type	Model	Electrical entry	Features
Solid state	D-Y69A, Y69B, Y7PV	Grommet (Perpendicular)	—
	D-Y7NWW, Y7PWW, Y7BWW		Diagnostic indication (2-colour indicator)
	D-F59, F5P, J59	Grommet (In-line)	—
	D-Y59A, Y59B, Y7P		—
	D-F59W, F5PW, J59W		Diagnostic indication (2-colour indicator)
	D-Y7NW, Y7PW, Y7BW		Water resistant (2-colour indicator)
	D-F5BA, Y7BA		With timer
	D-F5NT		With diagnostic output (2-colour indicator)
	D-F59F		—
	D-P3DWA		Magnetic field resistant (2-colour indicator)
	D-P4DW	—	
	D-G39, K39	Terminal conduit	—
	Reed	D-A53, A54, A56, Z73, Z76	Grommet (In-line)
D-A64, A67, Z80		Without indicator light	
D-A59W		Diagnostic indication (2-colour indicator)	
D-A33, A34		Terminal conduit	—
D-A44		DIN terminal	—

\* Normally closed (NC = b contact) solid state auto switches (D-M9□E(V)/Y7G/Y7H) are also available. For details, refer to the catalogue on [www.smc.eu](http://www.smc.eu).

## Auto Switch Proper Mounting Position (Detection at stroke end) and Mounting Height

### <Tie-rod mounting>

D-Y59□/Y69□/Y7P/Y7PV  
D-Y7G/H  
D-Y7□W/Y7□WV/Y7BA  
D-Z7□/Z80

D-F5□/J59  
D-F5□W/J59W/F5BA  
D-F59F/F5NT

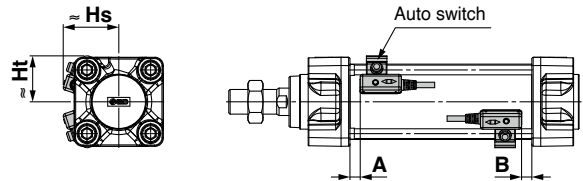
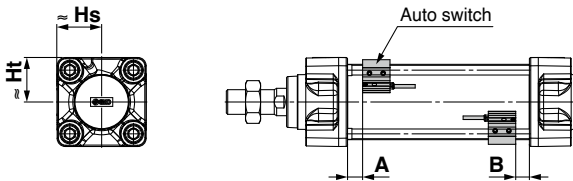

D-P3DWA

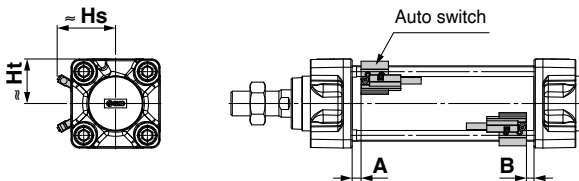

D-P4DW

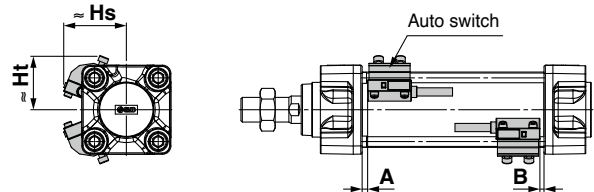

D-A5□/A6□  
D-A59W

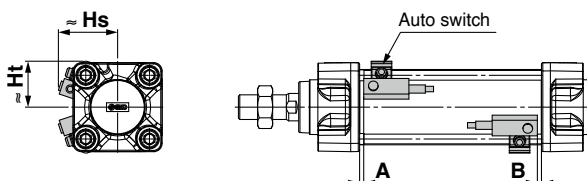

# MB2 Series

## Auto Switch Proper Mounting Position (Detection at stroke end) and Mounting Height

<Band mounting>

D-G39/K39/A3□

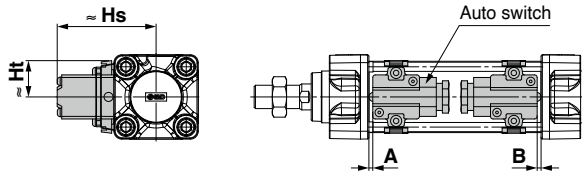

D-A44

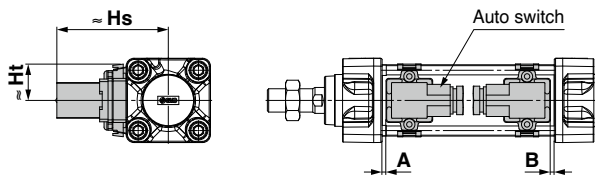

## Auto Switch Proper Mounting Position (Standard, Double rod)

[mm]

Auto switch model	D-F5□ D-F5□W D-J59 D-J59W D-F5BA D-F59F		D-F5NT		D-A5□ D-A6□		D-A59W		D-G39 D-K39 D-A3□ D-A44		D-Y59□ D-Y69□ D-Y7P D-Y7PV D-Y7G/H D-Y7□W D-Y7□WV D-Y7BA D-Z7□ D-Z80		D-P3DWA		D-P4DW	
	A	B	A	B	A	B	A	B	A	B	A	B	A	B	A	B
32	6.5	6	11.5	11	0	0	4	3.5	0	0	3.5	3	5.5	5	3	2.5
40	6	5.5	11	10.5	0	0	3.5	3	0	0	3	2.5	5	4.5	2.5	2
50	7.5	6.5	12.5	11.5	1	0	5	4	1	0	4.5	3.5	6.5	5.5	4	3
63	7.5	6.5	12.5	11.5	1	0	5	4	1	0	4.5	3.5	6.5	5.5	4	3
80	11	9	16	14	4.5	2.5	8.5	6.5	4.5	2.5	8	6	10	8	7.5	5.5
100	11	9	16	14	4.5	2.5	8.5	6.5	4.5	2.5	8	6	10	8	7.5	5.5
125	12.5	12.5	17.5	17.5	6	6	10	10	6	6	9.5	9.5	11.5	11.5	9	9

## Auto Switch Mounting Height (Standard, Double rod)

[mm]

Auto switch model	D-F5□ D-J59 D-F59F D-F5□W D-J59W D-F5BA D-F5NT		D-A5□ D-A6□ D-A59W		D-G39 D-K39 D-A3□		D-A44		D-Y59□ D-Y7P D-Y7G/H D-Y7□W D-Y7BA D-Z7□ D-Z80		D-Y69□ D-Y7PV D-Y7□WV		D-P3DWA		D-P4DW	
	Hs	Ht	Hs	Ht	Hs	Ht	Hs	Ht	Hs	Ht	Hs	Ht	Hs	Ht	Hs	Ht
32	32.5	25	35	24.5	67	27.5	77	27.5	25.5	23	26.5	23	38	31	38	31
40	36.5	27.5	38.5	27.5	71.5	27.5	81.5	27.5	29.5	26	30	26	39	25.5	42	33
50	41	34	43.5	34.5	77	—	87	—	33.5	31	34.5	31	43	31	46.5	39
63	46	39	48.5	39.5	83.5	—	93.5	—	39	36	40	36	48	36	51.5	44
80	52.5	46.5	55	46.5	92.5	—	103	—	47.5	45	48.5	45	56.5	45	58	51.5
100	59.5	55	62	55	103	—	113.5	—	55.5	53.5	56.5	53.5	64.5	53.5	65.5	60.5
125	70.5	66.5	71.5	66.5	115	—	125	—	67.5	65	68.5	65	76	64.5	76.5	72



## Minimum Stroke for Auto Switch Mounting

### Mounting Brackets Except Trunnion

n: Number of auto switches [mm]

Auto switch model	Number of auto switches	Ø 32	Ø 40	Ø 50	Ø 63	Ø 80	Ø 100	Ø 125
D-F5□ D-J59 D-F5□W D-J59W D-F59F D-F5BA	2 (Different surfaces, Same surface) 1	20						
	n	$20 + 55 \frac{(n-2)}{2}$ (n = 2, 4, 6, 8···)*1						
D-F5NT	2 (Different surfaces, Same surface) 1	25						
	n	$25 + 55 \frac{(n-2)}{2}$ (n = 2, 4, 6, 8···)*1						
D-A5□ D-A6□ D-A59W	2 (Different surfaces, Same surface) 1	20						
	n	$20 + 55 \frac{(n-2)}{2}$ (n = 2, 4, 6, 8···)*1						
D-G39 D-K39 D-A3□	2 (Different surfaces)	35						
	2 (Same surface)	100						
	n (Different surfaces)	$35 + 30 (n - 2)$ (n = 2, 3, 4···)						
	n (Same surface)	$100 + 100 (n - 2)$ (n = 2, 3, 4···)						
	1	10						
D-A44	2 (Different surfaces)	35						
	2 (Same surface)	55						
	n (Different surfaces)	$35 + 30 (n - 2)$ (n = 2, 3, 4···)						
	n (Same surface)	$55 + 50 (n - 2)$ (n = 2, 3, 4···)						
	1	10						
D-Y59□ D-Y7P D-Y7G/H D-Y7□W D-Z7□ D-Z80	2 (Different surfaces, Same surface) 1	15						
	n	$15 + 40 \frac{(n-2)}{2}$ (n = 2, 4, 6, 8···)*1						
D-Y69□ D-Y7PV D-Y7□WV	2 (Different surfaces, Same surface) 1	10						
	n	$10 + 30 \frac{(n-2)}{2}$ (n = 2, 4, 6, 8···)*1						
D-Y7BA	2 (Different surfaces, Same surface) 1	20						
	n	$20 + 45 \frac{(n-2)}{2}$ (n = 2, 4, 6, 8···)*1						
D-P3DWA	2 (Different surfaces, Same surface) 1	20			15			
	n	$20 + 50 \frac{(n-2)}{2}$ (n = 2, 4, 6, 8···)*1			$15 + 50 \frac{(n-2)}{2}$ (n = 2, 4, 6, 8···)*1			
D-P4DW	2 (Different surfaces, Same surface) 1	30			25			
	n	$30 + 65 \frac{(n-2)}{2}$ (n = 2, 4, 6, 8···)*1			$25 + 65 \frac{(n-2)}{2}$ (n = 2, 4, 6, 8···)*1			

\*1 When "n" is an odd number, an even number that is one larger than the odd number is to be used for the calculation.

# MB2 Series

## Minimum Stroke for Auto Switch Mounting

### Trunnion

n: Number of auto switches [mm]

Auto switch model	Number of auto switches	Ø 32	Ø 40	Ø 50	Ø 63	Ø 80	Ø 100	Ø 125	
D-F5□ D-J59 D-F5□W D-J59W D-F59F D-F5BA	2 (Different surfaces, Same surface) 1	90	95		110	115	120	130	
	n	$90 + 55 \frac{(n-4)}{2}$ (n = 4, 8, 12, 16...)*2	$95 + 55 \frac{(n-4)}{2}$ (n = 4, 8, 12, 16...)*2		$110 + 55 \frac{(n-4)}{2}$ (n = 4, 8, 12, 16...)*2	$115 + 55 \frac{(n-4)}{2}$ (n = 4, 8, 12, 16...)*2	$120 + 55 \frac{(n-4)}{2}$ (n = 4, 8, 12, 16...)*2	$130 + 55 \frac{(n-4)}{2}$ (n = 4, 8, 12, 16...)*2	
D-F5NT	2 (Different surfaces, Same surface) 1	100	105		120	125	130	140	
	n	$100 + 55 \frac{(n-4)}{2}$ (n = 4, 8, 12, 16...)*2	$105 + 55 \frac{(n-4)}{2}$ (n = 4, 8, 12, 16...)*2		$120 + 55 \frac{(n-4)}{2}$ (n = 4, 8, 12, 16...)*2	$125 + 55 \frac{(n-4)}{2}$ (n = 4, 8, 12, 16...)*2	$130 + 55 \frac{(n-4)}{2}$ (n = 4, 8, 12, 16...)*2	$140 + 55 \frac{(n-4)}{2}$ (n = 4, 8, 12, 16...)*2	
D-A5□ D-A6□	2 (Different surfaces, Same surface) 1	60		85	105	110	115		
	n	$60 + 55 \frac{(n-4)}{2}$ (n = 4, 8, 12, 16...)*2		$85 + 55 \frac{(n-4)}{2}$ (n = 4, 8, 12, 16...)*2	$105 + 55 \frac{(n-4)}{2}$ (n = 4, 8, 12, 16...)*2	$110 + 55 \frac{(n-4)}{2}$ (n = 4, 8, 12, 16...)*2	$115 + 55 \frac{(n-4)}{2}$ (n = 4, 8, 12, 16...)*2		
D-A59W	2 (Different surfaces, Same surface) 1	70		90	110	115	120	125	
	n	$70 + 55 \frac{(n-4)}{2}$ (n = 4, 8, 12, 16...)*2		$90 + 55 \frac{(n-4)}{2}$ (n = 4, 8, 12, 16...)*2	$110 + 55 \frac{(n-4)}{2}$ (n = 4, 8, 12, 16...)*2	$115 + 55 \frac{(n-4)}{2}$ (n = 4, 8, 12, 16...)*2	$120 + 55 \frac{(n-4)}{2}$ (n = 4, 8, 12, 16...)*2	$125 + 55 \frac{(n-4)}{2}$ (n = 4, 8, 12, 16...)*2	
D-G39 D-K39 D-A3□	2 (Different surfaces)	60	65		75	80	85	90	
	2 (Same surface)	100							
	n (Different surfaces)	$60 + 30(n-2)$ (n = 2, 4, 6, 8...)*1	$60 + 30(n-2)$ (n = 2, 4, 6, 8...)*1		$75 + 30(n-2)$ (n = 2, 4, 6, 8...)*1	$80 + 30(n-2)$ (n = 2, 4, 6, 8...)*1	$85 + 30(n-2)$ (n = 2, 4, 6, 8...)*1	$90 + 30(n-2)$ (n = 2, 4, 6, 8...)*1	
	n (Same surface)	$100 + 100(n-2)$ (n = 2, 4, 6, 8...)*1							
	1	60	65		75	80	85	90	
D-A44	2 (Different surfaces)	70	75		80		85	90	
	2 (Same surface)	100							
	n (Different surfaces)	$70 + 30(n-2)$ (n = 2, 4, 6, 8...)*1	$75 + 30(n-2)$ (n = 2, 4, 6, 8...)*1		$80 + 30(n-2)$ (n = 2, 4, 6, 8...)*1		$85 + 30(n-2)$ (n = 2, 4, 6, 8...)*1	$90 + 30(n-2)$ (n = 2, 4, 6, 8...)*1	
	n (Same surface)	$70 + 50(n-2)$ (n = 2, 4, 6, 8...)*1	$75 + 50(n-2)$ (n = 2, 4, 6, 8...)*1		$80 + 50(n-2)$ (n = 2, 4, 6, 8...)*1		$85 + 50(n-2)$ (n = 2, 4, 6, 8...)*1	$90 + 50(n-2)$ (n = 2, 4, 6, 8...)*1	
	1	70	75		80		85	90	
D-Y59□ D-Y7P D-Y7G/H D-Y7□W D-Z7□ D-Z80	2 (Different surfaces, Same surface) 1	80	85	90		95	100	105	
	n	$80 + 40 \frac{(n-4)}{2}$ (n = 4, 8, 12, 16...)*2	$85 + 40 \frac{(n-4)}{2}$ (n = 4, 8, 12, 16...)*2	$90 + 40 \frac{(n-4)}{2}$ (n = 4, 8, 12, 16...)*2		$95 + 40 \frac{(n-4)}{2}$ (n = 4, 8, 12, 16...)*2	$100 + 40 \frac{(n-4)}{2}$ (n = 4, 8, 12, 16...)*2	$105 + 40 \frac{(n-4)}{2}$ (n = 4, 8, 12, 16...)*2	
D-Y69□ D-Y7PV D-Y7□WV	2 (Different surfaces, Same surface) 1	60	65		70	75	85		
	n	$60 + 30 \frac{(n-4)}{2}$ (n = 4, 8, 12, 16...)*2	$65 + 30 \frac{(n-4)}{2}$ (n = 4, 8, 12, 16...)*2		$70 + 30 \frac{(n-4)}{2}$ (n = 4, 8, 12, 16...)*2	$75 + 30 \frac{(n-4)}{2}$ (n = 4, 8, 12, 16...)*2	$85 + 30 \frac{(n-4)}{2}$ (n = 4, 8, 12, 16...)*2		
D-Y7BA	2 (Different surfaces, Same surface) 1	85	90		100	105	110	115	
	n	$85 + 45 \frac{(n-4)}{2}$ (n = 4, 8, 12, 16...)*2	$90 + 45 \frac{(n-4)}{2}$ (n = 4, 8, 12, 16...)*2		$100 + 45 \frac{(n-4)}{2}$ (n = 4, 8, 12, 16...)*2	$105 + 45 \frac{(n-4)}{2}$ (n = 4, 8, 12, 16...)*2	$110 + 45 \frac{(n-4)}{2}$ (n = 4, 8, 12, 16...)*2	$115 + 45 \frac{(n-4)}{2}$ (n = 4, 8, 12, 16...)*2	
D-P3DWA	2 (Different surfaces, Same surface) 1	85	90		100	105	110	120	
	n	$85 + 50 \frac{(n-4)}{2}$ (n = 4, 8, 12, 16...)*2	$90 + 50 \frac{(n-4)}{2}$ (n = 4, 8, 12, 16...)*2		$100 + 50 \frac{(n-4)}{2}$ (n = 4, 8, 12, 16...)*2	$105 + 50 \frac{(n-4)}{2}$ (n = 4, 8, 12, 16...)*2	$110 + 50 \frac{(n-4)}{2}$ (n = 4, 8, 12, 16...)*2	$120 + 50 \frac{(n-4)}{2}$ (n = 4, 8, 12, 16...)*2	
D-P4DW	2 (Different surfaces, Same surface) 1	120		130		140		150	
	n	$120 + 65 \frac{(n-4)}{2}$ (n = 4, 8, 12, 16...)*2		$130 + 65 \frac{(n-4)}{2}$ (n = 4, 8, 12, 16...)*2		$140 + 65 \frac{(n-4)}{2}$ (n = 4, 8, 12, 16...)*2		$150 + 65 \frac{(n-4)}{2}$ (n = 4, 8, 12, 16...)*2	

\*1 When "n" is an odd number, an even number that is one larger than the odd number is to be used for the calculation.

\*2 When "n" is an odd number, a multiple of 4 that is larger than the odd number is to be used for the calculation.

## Auto Switch Mounting Brackets/Part Nos.

Auto switch model	Bore size [mm]						
	Ø 32	Ø 40	Ø 50	Ø 63	Ø 80	Ø 100	Ø 125
D-A3□/A44 D-G39/K39	BMB2-032	BMB2-040	BMB1-050	BMB1-063	BMB1-080	BMB1-100	BS1-125
D-F5□/J59 D-F5□W/J59W D-F59F/F5BA D-F5NT D-A5□/A6□/A59W	BT-03	BT-03	BT-05	BT-05	BT-06	BT-06	BT-08
D-P3DWA	BA10-032S	BA10-040S	BA10-050S	BA10-050S	BA10-063S	BA10-063S	BA10-080S
D-P4DW	BMB3T-040	BMB3T-040	BMB3T-050	BMB3T-050	BMB3T-080	BMB3T-080	BAP2T-080
D-Y59□/Y69□ D-Y7P/Y7PV D-Y7G/H D-Y7□W/Y7□WV D-Y7BA D-Z7□/Z80	BMB4-032	BMB4-032	BMB4-050	BMB4-050	BA4-063	BA4-063	BA4-080

### [Stainless Steel Mounting Screw]

The following stainless steel mounting screw kit (including set screws) is available. Use it in accordance with the operating environment. (Since the auto switch mounting bracket is not included, order it separately.)

BBA1: For D-A5/A6/F5/J5 types

- \* For details on the BBA1, refer to the "How to Mount and Move the Auto Switch" section in the **catalogue on [www.smc.eu](http://www.smc.eu)**.  
The above stainless steel screws are used when a cylinder is shipped with the D-F 5 BA auto switch. When only one auto switch is shipped independently, the BBA1 is attached.
- \* When using the D-Y 7 BA, do not use the steel set screws which are included with the auto switch mounting brackets above (BMB 4 - □□□, BA4-□□□). Order a stainless steel screw kit (BBA1) separately before use.

## Operating Range

Auto switch model	Bore size [mm]						
	32	40	50	63	80	100	125
D-Y59□/Y69□ D-Y7P/Y7□V D-Y7G/H D-Y7□W/Y7□WV D-Y7BA	5.5	5.5	7	7.5	6.5	5.5	7
D-F5□/J59 D-F5□W/J59W D-F5BA/F5NT D-F59F	3.5	4	4	4.5	4.5	4.5	5
D-G39/K39	9	9	9	10	10	11	11
D-P3DWA	3	4.5	4.5	5	5	5.5	6.5
D-P4DW	4	4	4	4.5	4	4.5	4.5
D-Z7□/Z80	7.5	8.5	7.5	9.5	9.5	10.5	13
D-A5□/A6□	9	9	10	11	11	11	10
D-A59W	13	13	13	14	14	15	17
D-A3□/A44	9	9	10	11	11	11	10

- \* Values which include hysteresis are for reference purposes only. They are not a guarantee (assuming approx. ±30 % dispersion) and may change substantially depending on the ambient environment.

### <Mounting example for Ø 32, D-P3DWA>

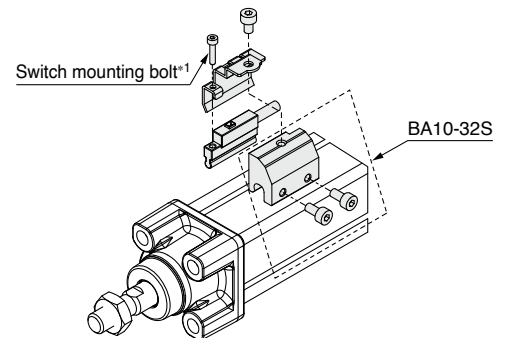

- \*1 The switch mounting bolt is supplied with the auto switch.

## Safety Instructions

These safety instructions are intended to prevent hazardous situations and/or equipment damage. These instructions indicate the level of potential hazard with the labels of “Caution,” “Warning” or “Danger.” They are all important notes for safety and must be followed in addition to International Standards (ISO/IEC)<sup>1)</sup>, and other safety regulations.

### Danger:

**Danger** indicates a hazard with a high level of risk which, if not avoided, will result in death or serious injury.

### Warning:

**Warning** indicates a hazard with a medium level of risk which, if not avoided, could result in death or serious injury.

### Caution:

**Caution** indicates a hazard with a low level of risk which, if not avoided, could result in minor or moderate injury.

- 1) ISO 4414: Pneumatic fluid power – General rules and safety requirements for systems and their components.
- ISO 4413: Hydraulic fluid power – General rules and safety requirements for systems and their components.
- IEC 60204-1: Safety of machinery – Electrical equipment of machines. (Part 1: General requirements)
- ISO 10218-1: Robots and robotic devices - Safety requirements for industrial robots - Part 1: Robots.
- etc.

## Warning

### 1. The compatibility of the product is the responsibility of the person who designs the equipment or decides its specifications.

Since the product specified here is used under various operating conditions, its compatibility with specific equipment must be decided by the person who designs the equipment or decides its specifications based on necessary analysis and test results. The expected performance and safety assurance of the equipment will be the responsibility of the person who has determined its compatibility with the product. This person should also continuously review all specifications of the product referring to its latest catalogue information, with a view to giving due consideration to any possibility of equipment failure when configuring the equipment.

### 2. Only personnel with appropriate training should operate machinery and equipment.

The product specified here may become unsafe if handled incorrectly. The assembly, operation and maintenance of machines or equipment including our products must be performed by an operator who is appropriately trained and experienced.

### 3. Do not service or attempt to remove product and machinery/equipment until safety is confirmed.

1. The inspection and maintenance of machinery/equipment should only be performed after measures to prevent falling or runaway of the driven objects have been confirmed.
2. When the product is to be removed, confirm that the safety measures as mentioned above are implemented and the power from any appropriate source is cut, and read and understand the specific product precautions of all relevant products carefully.
3. Before machinery/equipment is restarted, take measures to prevent unexpected operation and malfunction.

### 4. Our products cannot be used beyond their specifications. Our products are not developed, designed, and manufactured to be used under the following conditions or environments. Use under such conditions or environments is not covered.

1. Conditions and environments outside of the given specifications, or use outdoors or in a place exposed to direct sunlight.
2. Use for nuclear power, railways, aviation, space equipment, ships, vehicles, military application, equipment affecting human life, body, and property, fuel equipment, entertainment equipment, emergency shut-off circuits, press clutches, brake circuits, safety equipment, etc., and use for applications that do not conform to standard specifications such as catalogues and operation manuals.
3. Use for interlock circuits, except for use with double interlock such as installing a mechanical protection function in case of failure. Please periodically inspect the product to confirm that the product is operating properly.

## Caution

**We develop, design, and manufacture our products to be used for automatic control equipment, and provide them for peaceful use in manufacturing industries.**

**Use in non-manufacturing industries is not covered.**

Products we manufacture and sell cannot be used for the purpose of transactions or certification specified in the Measurement Act.

The new Measurement Act prohibits use of any unit other than SI units in Japan.

## Limited warranty and Disclaimer/Compliance Requirements

The product used is subject to the following “Limited warranty and Disclaimer” and “Compliance Requirements”. Read and accept them before using the product.

### Limited warranty and Disclaimer

1. The warranty period of the product is 1 year in service or 1.5 years after the product is delivered, whichever is first.<sup>2)</sup> Also, the product may have specified durability, running distance or replacement parts. Please consult your nearest sales branch.
2. For any failure or damage reported within the warranty period which is clearly our responsibility, a replacement product or necessary parts will be provided. This limited warranty applies only to our product independently, and not to any other damage incurred due to the failure of the product.
3. Prior to using SMC products, please read and understand the warranty terms and disclaimers noted in the specified catalogue for the particular products.
- 2) Vacuum pads are excluded from this 1 year warranty. A vacuum pad is a consumable part, so it is warranted for a year after it is delivered. Also, even within the warranty period, the wear of a product due to the use of the vacuum pad or failure due to the deterioration of rubber material are not covered by the limited warranty.

### Compliance Requirements

1. The use of SMC products with production equipment for the manufacture of weapons of mass destruction (WMD) or any other weapon is strictly prohibited.
2. The exports of SMC products or technology from one country to another are governed by the relevant security laws and regulations of the countries involved in the transaction. Prior to the shipment of a SMC product to another country, assure that all local rules governing that export are known and followed.

## Safety Instructions

Be sure to read “Handling Precautions for SMC Products” (M-E03-3) before using.

## SMC Corporation (Europe)

<b>Austria</b>	+43 (0)2262622800	www.smc.at	office@smc.at
<b>Belgium</b>	+32 (0)33551464	www.smc.be	info@smc.be
<b>Bulgaria</b>	+359 (0)2807670	www.smc.bg	office@smc.bg
<b>Croatia</b>	+385 (0)13707288	www.smc.hr	office@smc.hr
<b>Czech Republic</b>	+420 541424611	www.smc.cz	office@smc.cz
<b>Denmark</b>	+45 70252900	www.smc.dk.com	smc@smcdk.com
<b>Estonia</b>	+372 651 0370	www.smcee.ee	info@smcee.ee
<b>Finland</b>	+358 207513513	www.smc.fi	smc.fi@smc.fi
<b>France</b>	+33 (0)164761000	www.smc-france.fr	supportclient@smc-france.fr
<b>Germany</b>	+49 (0)61034020	www.smc.de	info@smc.de
<b>Greece</b>	+30 210 2717265	www.smchellas.gr	sales@smchellas.gr
<b>Hungary</b>	+36 23513000	www.smc.hu	office@smc.hu
<b>Ireland</b>	+353 (0)14039000	www.smcautomation.ie	sales@smcautomation.ie
<b>Italy</b>	+39 03990691	www.smcitalia.it	mailbox@smcitalia.it
<b>Latvia</b>	+371 67817700	www.smc.lv	info@smc.lv

<b>Lithuania</b>	+370 5 2308118	www.smclt.lt	info@smclt.lt
<b>Netherlands</b>	+31 (0)205318888	www.smc.nl	info@smc.nl
<b>Norway</b>	+47 67129020	www.smc-norge.no	post@smc-norge.no
<b>Poland</b>	+48 222119600	www.smc.pl	sales@smc.pl
<b>Portugal</b>	+351 214724500	www.smc.eu	apoioclientept@smc.smces.es
<b>Romania</b>	+40 213205111	www.smcromania.ro	smcromania@smcromania.ro
<b>Russia</b>	+7 (812)3036600	www.smc.eu	sales@smcru.com
<b>Slovakia</b>	+421 (0)413213212	www.smc.sk	office@smc.sk
<b>Slovenia</b>	+386 (0)73885412	www.smc.si	office@smc.si
<b>Spain</b>	+34 945184100	www.smc.eu	post@smc.smces.es
<b>Sweden</b>	+46 (0)86031240	www.smc.nu	smc@smc.nu
<b>Switzerland</b>	+41 (0)523963131	www.smc.ch	info@smc.ch
<b>Turkey</b>	+90 212 489 0 440	www.smcturkey.com.tr	info@smcturkey.com.tr
<b>UK</b>	+44 (0)845 121 5122	www.smc.uk	sales@smc.uk

**South Africa** +27 10 900 1233    www.smzca.co.za    zasales@smzca.co.za