

Dust-tight/Water-jet-proof (IP65 Equivalent)

# Electric Actuator/ Slider Type

Battery-less Absolute (Step Motor 24 VDC)

New



For details, refer to page 25.

RoHS

## Improved Dust and Water-jet Resistance



With internal battery-less absolute encoder

- After power supply is restored, it is possible to restart from the last stop position.
- Reduced maintenance (No need to manage or replace batteries)

Step Motor Controller JXC□ Series



Battery-less Absolute Type (Step Motor 24 VDC)

■ Direct input type

<Supported networks>



■ Step Data Input Type



# LEFSW Series



CAT.EUS100-163A-UK

# A dust-tight and water-jet-resistant (IP65 equivalent\*<sup>1</sup>) slider type product

\*1 IP65 Equivalence

The dust-tight and water-jet-resistant performance of this product's motor part is equivalent to IP65. However, since the actuator part has an opening, an IP65 rating for the actuator body cannot be guaranteed.

A special wear-resistant seal band is mounted on the bottom to prevent dust and water from entering the inside of the product.

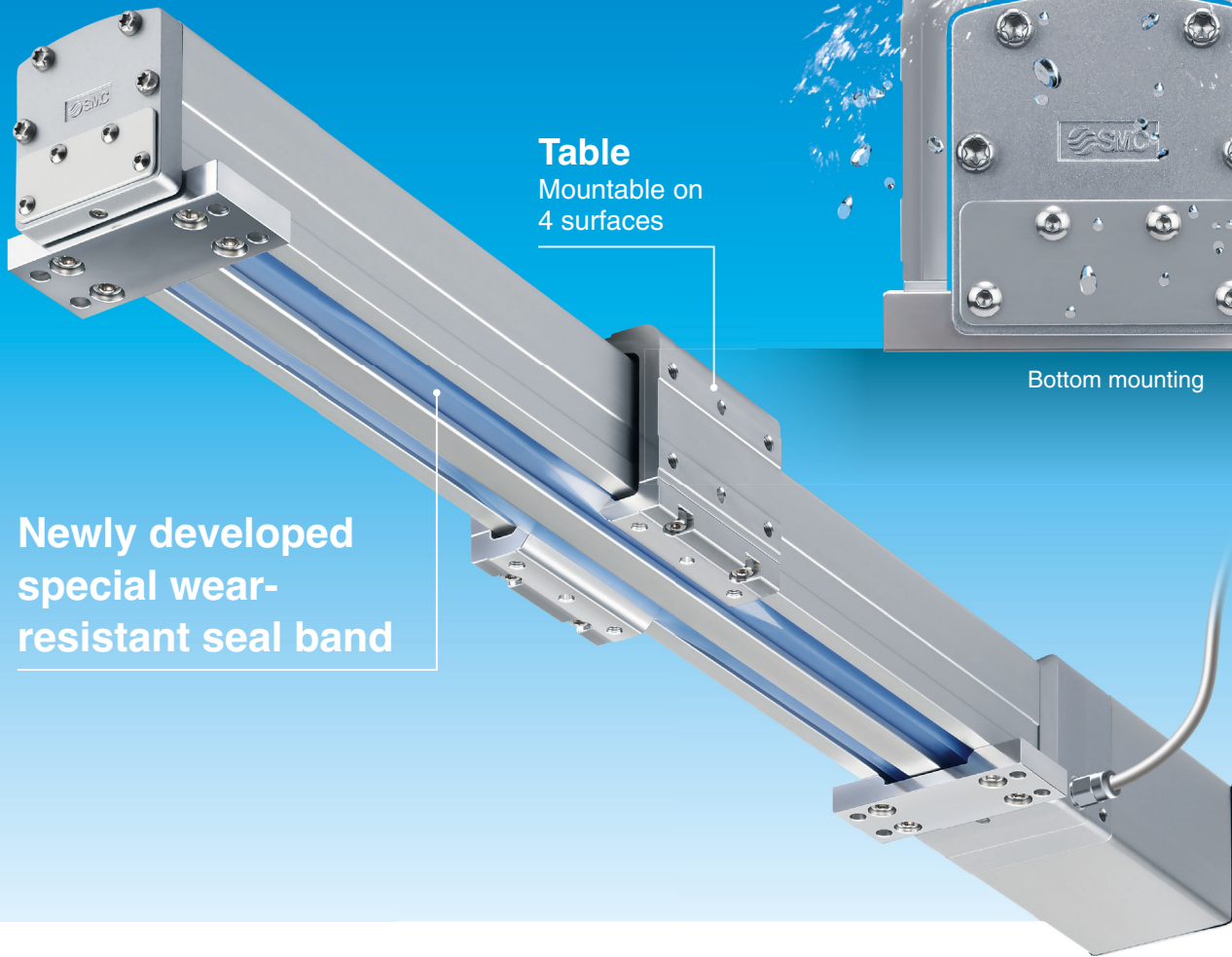

Newly developed special wear-resistant seal band

Table  
Mountable on 4 surfaces

Bottom mounting



Aluminium cover  
Protects the motor

Metal connectors  
IP65 compliant, prevents ingress of dust and water  
Higher resistance  
Removable and replaceable

Work load

Max. **65 kg**<sup>\*2</sup>



Stroke

Max. **1200 mm**<sup>\*3</sup>

\*2 Size 40, Lead B \*3 Size 40

## Related Products

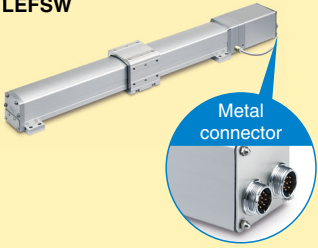
**Dust-tight/Water-jet-proof (IP65 Equivalent/IP67 Equivalent), Dust-tight/Water-jet-proof (IP65 Equivalent) Variations**

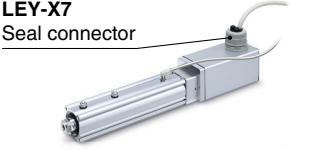
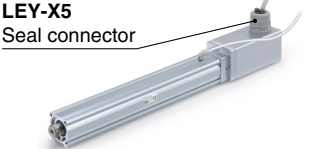
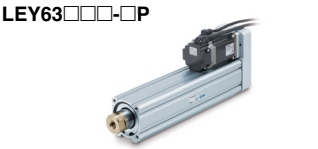
Series	Dust-tight/Water-jet-proof		Size	Battery-less Absolute (Step Motor 24 VDC)	Incremental (Step Motor 24 VDC)	Incremental (Servo Motor 24 VDC)	AC Servo Motor	Page
	IP65 Equivalent/ IP67 Equivalent	IP65 Equivalent						
<b>LEFSW</b> 	Series		16 25 32 40	●				p. 7
<b>LEY□E-X8</b> 	●		25 32 40	●				
<b>LEY-X7</b> Seal connector 	●		25 32 40		●	●		
<b>LEY-X5</b> Seal connector 		●	25 32		●	●	●	
<b>LEY63□□□-□P</b> 		●	63				●	

System Construction/General Purpose I/O

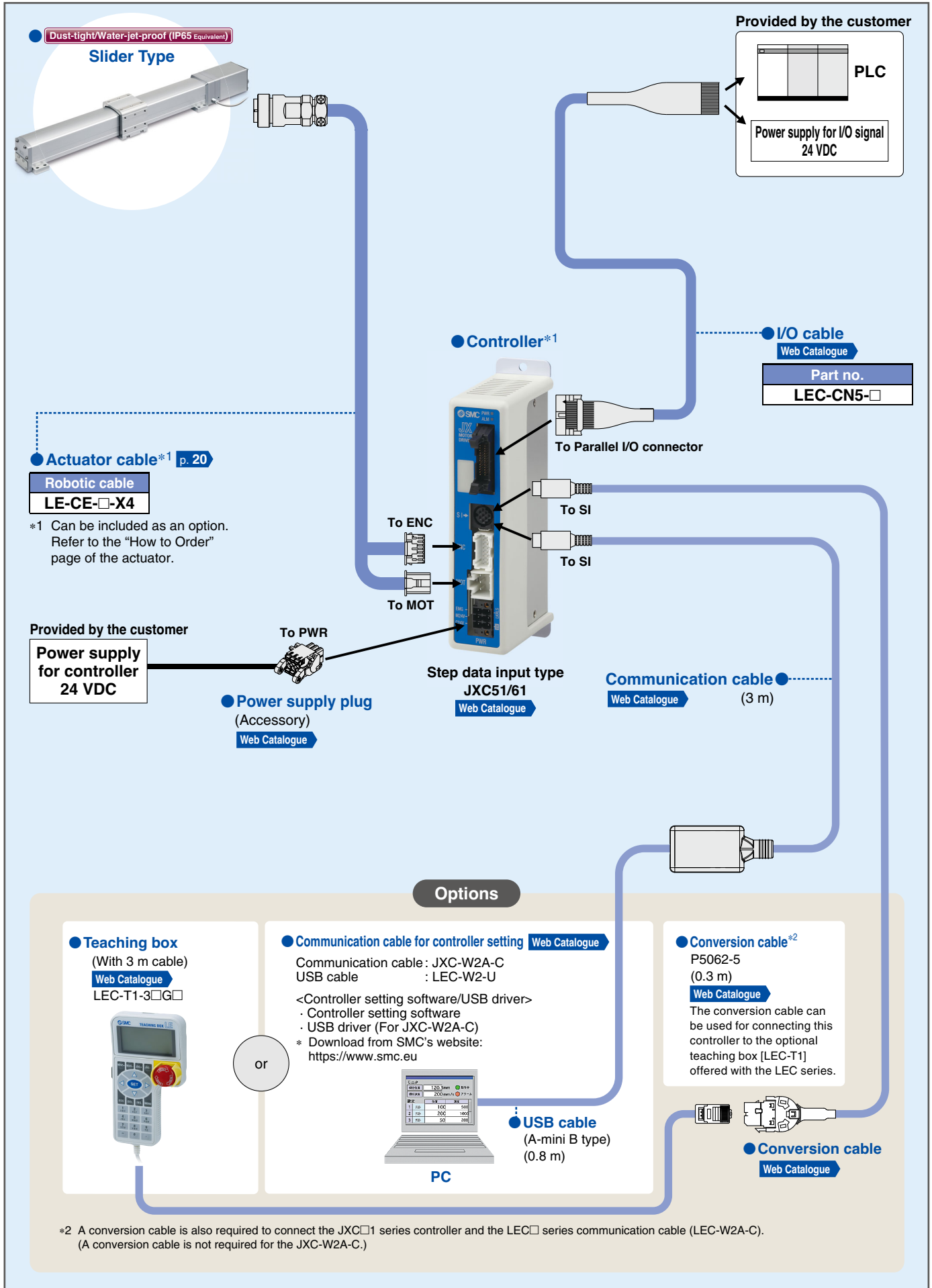

# System Construction/Fieldbus Network

(EtherCAT/EtherNet/IP™/PROFINET/DeviceNet®/IO-Link/CC-Link Direct Input Type)

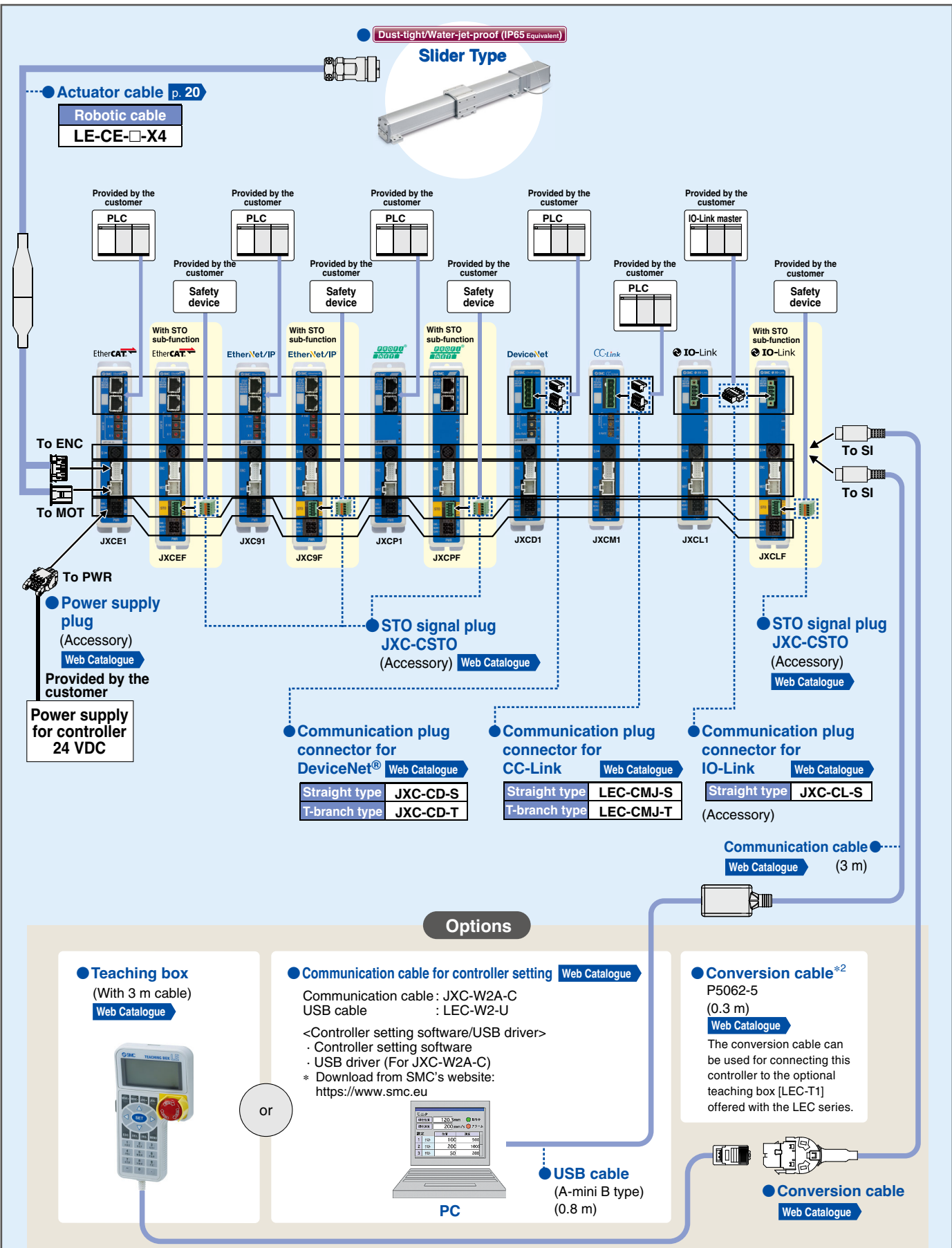

\*1 A conversion cable is also required to connect the JXC□□ series controller and the LEC□ series communication cable (LEC-W2A-C). (A conversion cable is not required for the JXC-W2A-C.)



# Electric Actuator

Dust-tight/Water-jet-proof (IP65 Equivalent) **Slider Type**

Dust-tight/Water-jet-proof (IP65 Equivalent) **Slider Type LEFSW Series**

Battery-less Absolute (Step Motor 24 VDC)

p. 11



## CONTENTS

Model Selection .....	p. 7
How to Order .....	p. 11
Specifications .....	p. 13
Weight .....	p. 13
Construction .....	p. 14
Dimensions .....	p. 15
Option .....	p. 20
<b>JXC51/61/E□/9□/P□/D1/L□/M1 Series</b> Precautions Relating to Differences in Controller Versions .....	p. 21
Specific Product Precautions .....	p. 23
<b>CE/UKCA/UL-compliance List</b> .....	p. 25

# Model Selection



## Selection Procedure



## Selection Example

### Operating conditions

- Workpiece mass: 5 [kg]
- Speed: 300 [mm/s]
- Acceleration/Deceleration: 3000 [mm/s<sup>2</sup>]
- Stroke: 200 [mm]
- Mounting orientation: Horizontal upward

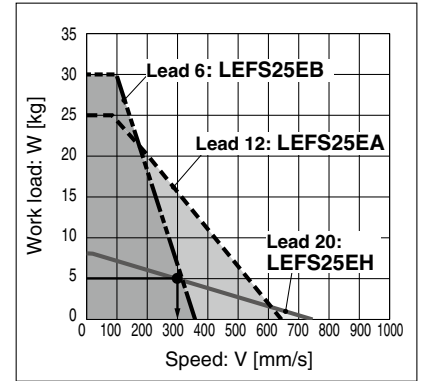
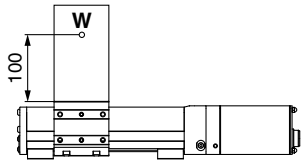

<Speed-Work load graph>  
(LEFSW25/Battery-less absolute)

### Step 1 Check the work load-speed. <Speed-Work load graph> (page 8)

Select a model based on the workpiece mass and speed while referencing the speed-work load graph.  
Selection example) The LEFSW25EA-200 can be temporarily selected as a possible candidate based on the graph shown on the right side.

### Step 2 Check the cycle time.

Calculate the cycle time using the following calculation method.

#### Cycle time:

T can be found from the following equation.

$$T = T1 + T2 + T3 + T4 \text{ [s]}$$

- T1: Acceleration time and T3: Deceleration time can be found by the following equation.

$$T1 = V/a1 \text{ [s]} \quad T3 = V/a2 \text{ [s]}$$

- T2: Constant speed time can be found from the following equation.

$$T2 = \frac{L - 0.5 \cdot V \cdot (T1 + T3)}{V} \text{ [s]}$$

- T4: Settling time varies depending on the conditions such as motor types, load and in position of the step data. Therefore, calculate the settling time while referencing the following value.

$$T4 = 0.2 \text{ [s]}$$

Calculation example)

T1 to T4 can be calculated as follows.

$$T1 = V/a1 = 300/3000 = 0.1 \text{ [s]}$$

$$T3 = V/a2 = 300/3000 = 0.1 \text{ [s]}$$

$$T2 = \frac{L - 0.5 \cdot V \cdot (T1 + T3)}{V} = \frac{200 - 0.5 \cdot 300 \cdot (0.1 + 0.1)}{300} = 0.57 \text{ [s]}$$

$$T4 = 0.2 \text{ [s]}$$

The cycle time can be found as follows.

$$T = T1 + T2 + T3 + T4 = 0.1 + 0.57 + 0.1 + 0.2 = 0.97 \text{ [s]}$$

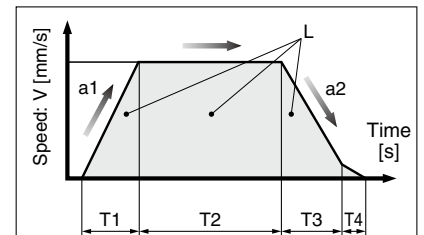

L : Stroke [mm] ... (Operating condition)  
V : Speed [mm/s] ... (Operating condition)  
a1 : Acceleration [mm/s<sup>2</sup>] ... (Operating condition)  
a2 : Deceleration [mm/s<sup>2</sup>] ... (Operating condition)

- T1: Acceleration time [s]  
Time until reaching the set speed
- T2: Constant speed time [s]  
Time while the actuator is operating at a constant speed
- T3: Deceleration time [s]  
Time from the beginning of the constant speed operation to stop
- T4: Settling time [s]  
Time until positioning is completed

### Step 3 Check the allowable moment. <Static allowable moment> (page 13)

#### <Dynamic allowable moment> (page 9)

Confirm the moment that applies to the actuator is within the allowable range for both static and dynamic conditions.

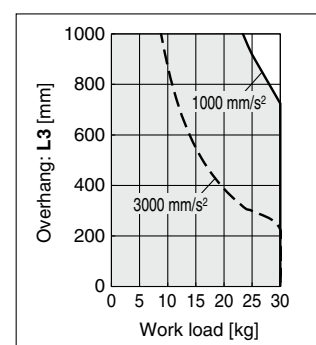
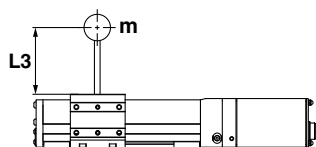

Based on the above calculation result, the LEFSW25EA-200 should be selected.



## Speed-Work Load Graph (Guide)

\* The following graphs show the values when the moving force is 100 %.

### LEFSW16: Ball Screw Drive

Horizontal

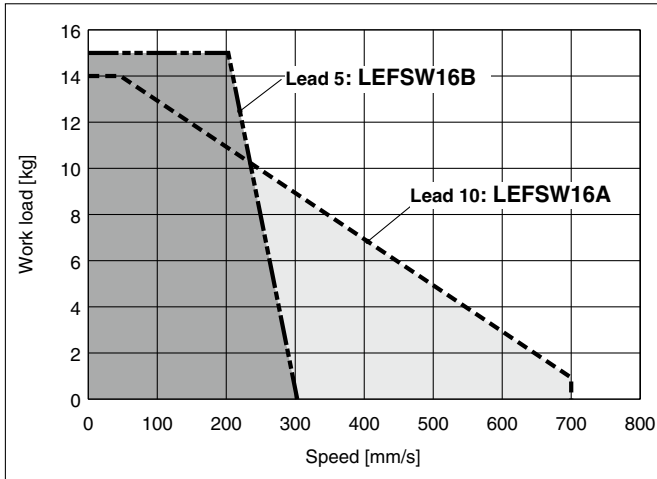

### LEFSW25: Ball Screw Drive

Horizontal

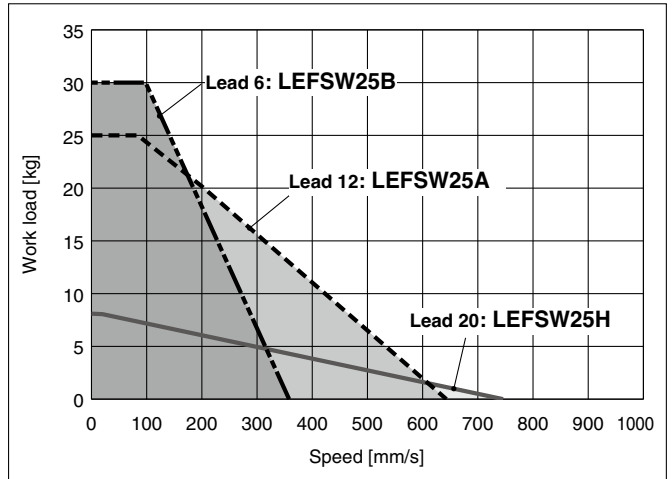

### LEFSW32: Ball Screw Drive

Horizontal

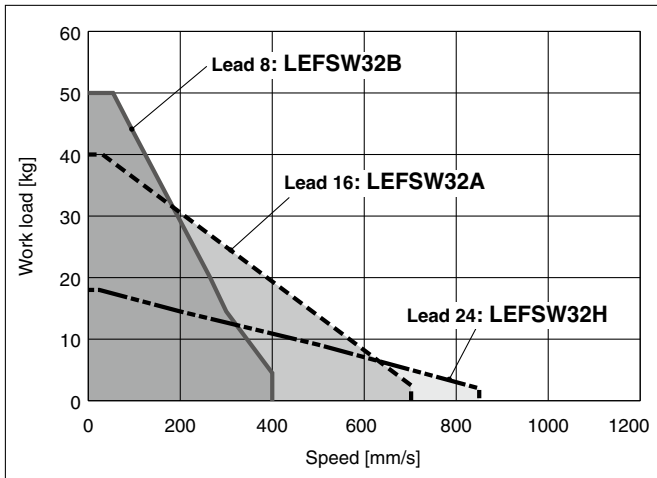

### LEFSW40: Ball Screw Drive

Horizontal

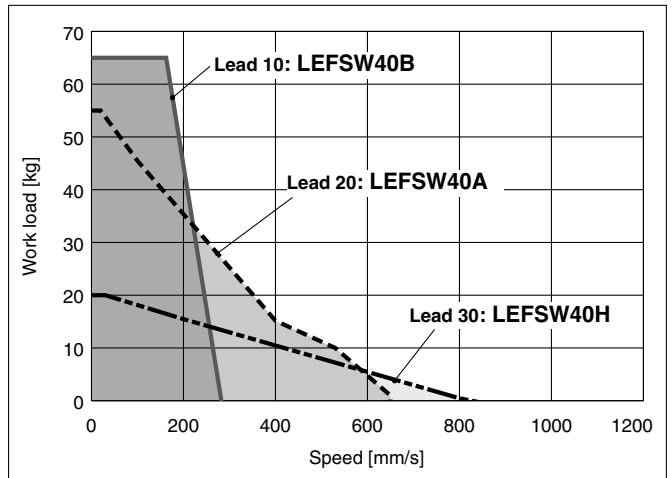

# LEFSW Series

Battery-less Absolute (Step Motor 24 VDC)

Dust-tight/Water-jet-proof (IP65 Equivalent)

\* These graphs show the amount of allowable overhang (guide unit) when the centre of gravity of the workpiece overhangs in one direction. When selecting the overhang, refer to the "Calculation of Guide Load Factor" or the Electric Actuator Model Selection Software for confirmation: <https://www.smc.eu>

## Dynamic Allowable Moment

Acceleration/Deceleration ——— 1000 mm/s<sup>2</sup> - - - -3000 mm/s<sup>2</sup>

Orientation	Load overhanging direction m: Work load [kg] Me: Allowable moment [N·m] L: Overhang to the work load centre of gravity [mm]	Model			
		LEFSW16	LEFSW25	LEFSW32	LEFSW40
Horizontal/Bottom	X L1 [mm]				
	Y L2 [mm]				
	Z L3 [mm]				
Wall	X L4 [mm]				
	Y L5 [mm]				
	Z L6 [mm]				

## Calculation of Guide Load Factor

1. Decide operating conditions.

Model: LEFSW

Size: 16/25/32/40

Mounting orientation: Horizontal/Bottom/Wall

2. Select the target graph while referencing the model, size, and mounting orientation.

3. Based on the acceleration and work load, find the overhang [mm]:  $L_x/L_y/L_z$  from the graph.

4. Calculate the load factor for each direction.

$$\alpha_x = X_c/L_x, \alpha_y = Y_c/L_y, \alpha_z = Z_c/L_z$$

5. Confirm the total of  $\alpha_x$ ,  $\alpha_y$ , and  $\alpha_z$  is 1 or less.

$$\alpha_x + \alpha_y + \alpha_z \leq 1$$

When 1 is exceeded, please consider a reduction of acceleration and work load, or a change of the work load centre position and series.

Acceleration [mm/s<sup>2</sup>]:  $a$

Work load [kg]:  $m$

Work load centre position [mm]:  $X_c/Y_c/Z_c$

### Mounting orientation

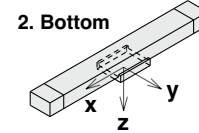
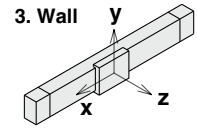
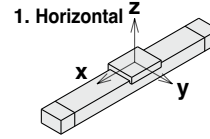

## Table Displacement (Reference Value)

- Load position: Centre of table

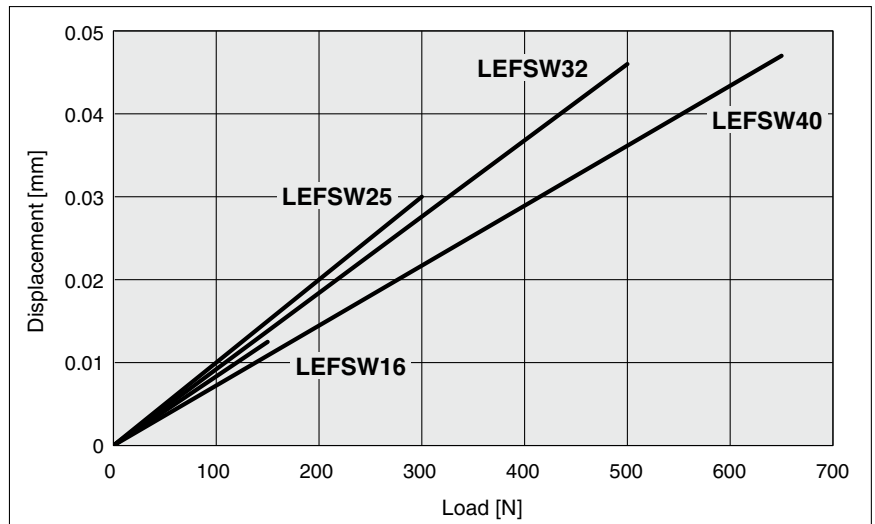
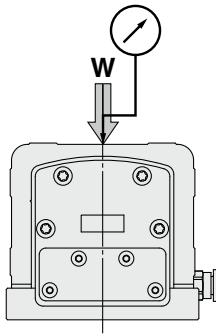

\* Measured value at a 300 mm stroke

- Load position: Offset (L)

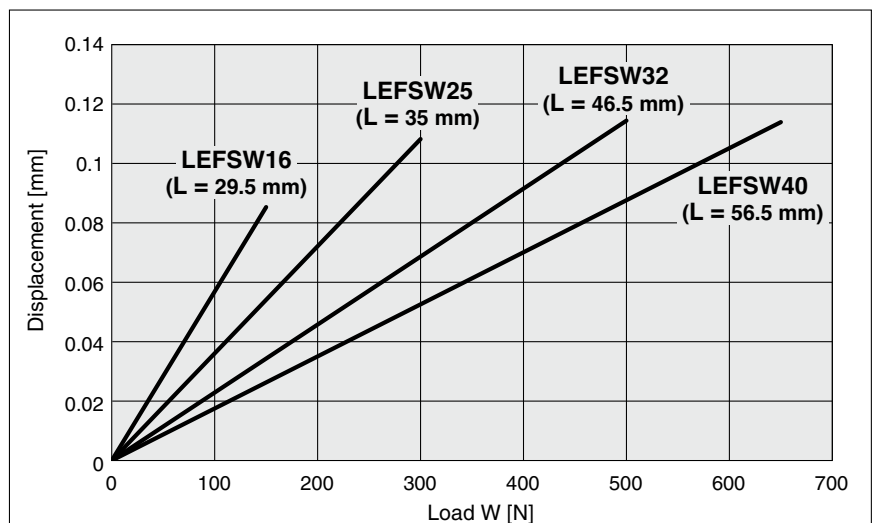
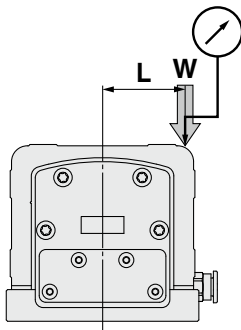

\* Measured value at a 300 mm stroke

Battery-less Absolute (Step Motor 24 VDC)

**Slider Type** Dust-tight/Water-jet-proof (IP65 Equivalent)



**LEFSW Series** LEFSW16/25/32/40



**How to Order**

**LEFSW** **32** **E** **A** - **200** - - **CD17T**

①
②
③
④
⑤
⑥
⑦

**① Size**

16
25
32
40

**② Motor type**

<b>E</b>	Battery-less Absolute (Step Motor 24 VDC)
----------	---

**③ Lead [mm]**

Symbol	LEFSW16	LEFSW25	LEFSW32	LEFSW40
<b>H</b>	—	20	24	30
<b>A</b>	10	12	16	20
<b>B</b>	5	6	8	10

**④ Stroke\*1 [mm]**

<b>50</b>	50
<b>to</b>	to
<b>1200</b>	1200

\*1 For details, refer to the applicable stroke table below.

**⑤ Mounting**

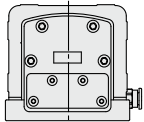
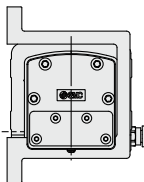
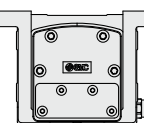
—	Floor	
<b>G</b>	Wall	
<b>J</b>	Ceiling	

**⑥ Actuator cable type/length**

Robotic cable [m]			
—	None	<b>R8</b>	8
<b>R1</b>	1.5	<b>RA</b>	10
<b>R3</b>	3	<b>RB</b>	15
<b>R5</b>	5	<b>RC</b>	20

**Applicable Stroke Table**

Size	Stroke																					
	50	100	150	200	250	300	350	400	450	500	550	600	650	700	750	800	850	900	950	1000	1100	1200
16	●	●	●	●	●	●	●	●	●	●	—	—	—	—	—	—	—	—	—	—	—	—
25	●	●	●	●	●	●	●	●	●	●	●	●	●	●	●	●	—	—	—	—	—	—
32	●	●	●	●	●	●	●	●	●	●	●	●	●	●	●	●	●	●	●	●	—	—
40	—	—	●	●	●	●	●	●	●	●	●	●	●	●	●	●	●	●	●	●	●	●

## 7 Controller

—	Without controller
C□□□□	With controller

**C P 1 7 3**

### Interface (Communication protocol/Input/Output)

Symbol	Type	Number of axes, Special specification	
		Standard	With STO sub-function
5	Parallel input (NPN)	●	
6	Parallel input (PNP)	●	
E	EtherCAT	●	●
9	EtherNet/IP™	●	●
P	PROFINET	●	●
D	DeviceNet®	●	
L	IO-Link	●	●
M	CC-Link	●	

### Mounting

7	Screw mounting
8*3	DIN rail

### Number of axes, Special specification

Symbol	Number of axes	Specification
1	Single axis	Standard
F	Single axis	With STO sub-function

### Communication plug connector, I/O cable\*4

Symbol	Type	Applicable interface
—	Without accessory	—
S	Straight type communication plug connector	DeviceNet® CC-Link Ver. 1.10
T	T-branch type communication plug connector	
1	I/O cable (1.5 m)	Parallel input (NPN) Parallel input (PNP)
3	I/O cable (3 m)	
5	I/O cable (5 m)	

- \*1 Please contact SMC for non-standard strokes as they are produced as special orders.
- \*2 Produced upon receipt of order
- \*3 The DIN rail is not included. It must be ordered separately.

- \*4 Select “—” for anything other than DeviceNet®, CC-Link, or parallel input. Select “S,” “T,” or “—” for DeviceNet® or CC-Link. Select “—,” “1,” “3,” or “5” for parallel input.

## ⚠ Caution

### [CE/UKCA-compliant products]

EMC compliance was tested by combining the electric actuator LEFSW series and the controller JXC series.

The EMC depends on the configuration of the customer's control panel and the relationship with other electrical equipment and wiring. Therefore, compliance with the EMC directive cannot be certified for SMC components incorporated into the customer's equipment under actual operating conditions. As a result, it is necessary for the customer to verify compliance with the EMC directive for the machinery and equipment as a whole.

### [Precautions relating to differences in controller versions]

When the JXC series is to be used in combination with the battery-less absolute encoder, use a controller that is version V3.4 or S3.4 or higher. For details, refer to page 21.

### [UL-certified products]

The JXC series controllers used in combination with electric actuators are UL certified.

## The actuator and controller are sold as a package.

Confirm that the combination of the controller and actuator is correct.

### <Check the following before use.>

- ① Check the actuator label for the model number. This number should match that of the controller.
- ② Parallel input (NPN or PNP)

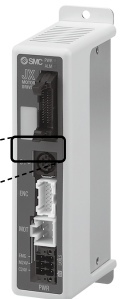
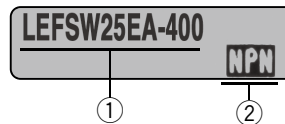

- \* Refer to the Operation Manual for using the products. Please download it via our website: <https://www.smc.eu>

## ■ Trademark

EtherNet/IP® is a registered trademark of ODVA, Inc.

DeviceNet® is a registered trademark of ODVA, Inc.

EtherCAT® is registered trademark and patented technology, licensed by Beckhoff Automation GmbH, Germany.

Type	Step data input type	EtherCAT direct input type	EtherCAT direct input type with STO sub-function	EtherNet/IP™ direct input type	EtherNet/IP™ direct input type with STO sub-function	PROFINET direct input type	PROFINET direct input type with STO sub-function	DeviceNet® direct input type	IO-Link direct input type	IO-Link direct input type with STO sub-function	CC-Link direct input type
Series	JXC51 JXC61	JXCE1	JXCEF	JXC91	JXC9F	JXCP1	JXC PF	JXCD1	JXCL1	JXCLF	JXCM1
Features	Parallel I/O	EtherCAT direct input	EtherCAT direct input with STO sub-function	EtherNet/IP™ direct input	EtherNet/IP™ direct input with STO sub-function	PROFINET direct input	PROFINET direct input with STO sub-function	DeviceNet® direct input	IO-Link direct input	IO-Link direct input with STO sub-function	CC-Link direct input
Compatible motor	Battery-less absolute (Step motor 24 VDC)										
Max. number of step data	64 points										
Power supply voltage	24 VDC										

# LEFSW Series

Battery-less Absolute (Step Motor 24 VDC)

Dust-tight/Water-jet-proof (IP65 Equivalent)

## Specifications

### Battery-less Absolute (Step Motor 24 VDC)

Model				LEFSW16E		LEFSW25E			LEFSW32E			LEFSW40E		
Stroke [mm] <sup>*1</sup>				50 to 500		50 to 800			50 to 1000			150 to 1200		
Work load [kg] <sup>*2</sup>		Horizontal		14	15	8	25	30	18	40	50	20	55	65
Vertical <sup>*2</sup> [mm/s]	In-line	Stroke range	Up to 450	10 to 700	5 to 300	20 to 750	12 to 640	6 to 350	24 to 850	16 to 700	8 to 400	30 to 800	20 to 650	10 to 280
			451 to 500	10 to 600	5 to 300	20 to 750	12 to 640	6 to 350	24 to 850	16 to 700	8 to 400	30 to 800	20 to 650	10 to 280
			501 to 600	—	—	20 to 750	12 to 540	6 to 270	24 to 850	16 to 700	8 to 400	30 to 800	20 to 650	10 to 280
			601 to 700	—	—	20 to 630	12 to 420	6 to 230	24 to 850	16 to 620	8 to 310	30 to 800	20 to 650	10 to 280
			701 to 800	—	—	20 to 550	12 to 330	6 to 180	24 to 750	16 to 500	8 to 250	30 to 800	20 to 650	10 to 280
			801 to 900	—	—	—	—	—	24 to 610	16 to 410	8 to 200	30 to 800	20 to 620	10 to 280
			901 to 1000	—	—	—	—	—	24 to 500	16 to 340	8 to 170	30 to 780	20 to 520	10 to 250
			1001 to 1100	—	—	—	—	—	—	—	—	30 to 660	20 to 440	10 to 220
1101 to 1200	—	—	—	—	—	—	—	—	30 to 570	20 to 380	10 to 190			
Max. acceleration/deceleration [mm/s <sup>2</sup> ]				3000										
Positioning repeatability [mm]				±0.02										
Lost motion [mm] <sup>*3</sup>				0.1 or less										
Lead [mm]				10	5	20	12	6	24	16	8	30	20	10
Impact/Vibration resistance [m/s <sup>2</sup> ] <sup>*4</sup>				50/20										
Actuation type				Ball screw (LEFS□)										
Guide type				Linear guide										
Enclosure				IP65 equivalent										
Purge air flow rate [L/min(ANR)] <sup>*7</sup>				20										
Static allowable moment <sup>*5</sup> [N·m]	Mep (Pitching)			10		27			46			110		
	Mey (Yawing)			10		27			46			110		
	Mer (Rolling)			20		52			101			207		
Operating temperature range [°C]				5 to 40										
Operating humidity range [%RH]				90 or less (No condensation)										
Motor size				□28		□42			□56.4					
Motor type				Battery-less absolute (Step motor 24 VDC)										
Encoder				Battery-less absolute										
Power supply voltage [V]				24 VDC ±10 %										
Power [W] <sup>*6</sup>				Max. power 49		Max. power 45			Max. power 99			Max. power 97		

- \*1 Please contact SMC for non-standard strokes as they are produced as special orders.
- \*2 Speed changes according to the work load. Check the "Speed-Work Load Graph (Guide)" on page 8. This product can only be mounted horizontally. Furthermore, if the cable length exceeds 5 m, then it will decrease by up to 10 % for each 5 m.
- \*3 A reference value for correcting errors in reciprocal operation
- \*4 Impact resistance: No malfunction occurred when the actuator was tested with a drop tester in both an axial direction and a perpendicular direction to the lead screw. (The test was performed with the actuator in the initial state.)  
Vibration resistance: No malfunction occurred in a test ranging between 45 to 2000 Hz. The test was performed in both an axial direction and a perpendicular direction to the lead screw. (The test was performed with the actuator in the initial state.)
- \*5 The static allowable moment is the amount of static moment which can be applied to the actuator when it is stopped.  
If the product is exposed to impact or repeated load, be sure to take adequate safety measures when using the product.
- \*6 Indicates the max. power during operation (including the controller)  
This value can be used for the selection of the power supply.
- \*7 When purging, please flow air from the purge air port. When not in use, close the port with a plug (KQ2P-06).

## Weight

Series	LEFSW16									
Stroke [mm]	50	100	150	200	250	300	350	400	450	500
Product weight [kg]	1.5	1.6	1.7	1.9	2.0	2.1	2.3	2.4	2.5	2.6

Series	LEFSW25															
Stroke [mm]	50	100	150	200	250	300	350	400	450	500	550	600	650	700	750	800
Product weight [kg]	2.3	2.4	2.6	2.8	2.9	3.1	3.3	3.5	3.6	3.8	4.0	4.1	4.3	4.5	4.7	4.8

Series	LEFSW32																			
Stroke [mm]	50	100	150	200	250	300	350	400	450	500	550	600	650	700	750	800	850	900	950	1000
Product weight [kg]	4.3	4.5	4.8	5.1	5.4	5.6	5.9	6.2	6.5	6.8	7.0	7.3	7.6	7.9	8.2	8.4	8.7	9.0	9.3	9.6

Series	LEFSW40																			
Stroke [mm]	150	200	250	300	350	400	450	500	550	600	650	700	750	800	850	900	950	1000	1100	1200
Product weight [kg]	6.9	7.2	7.6	7.9	8.3	8.6	9.0	9.3	9.7	10.0	10.4	10.7	11.1	11.4	11.7	12.1	12.4	12.8	13.5	14.2

## Construction: In-line Motor

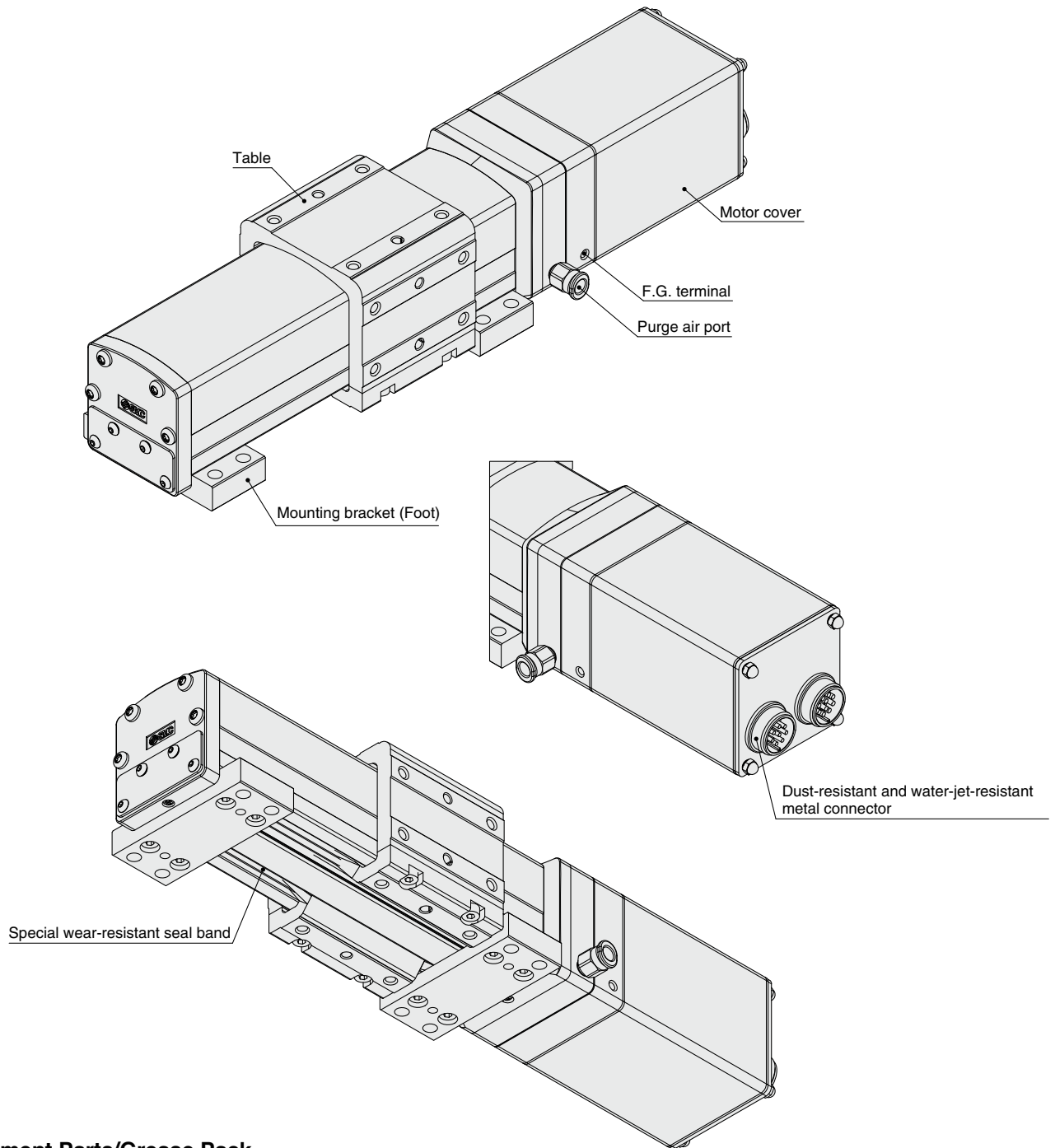

### Replacement Parts/Grease Pack

Applied portion	Order no.
Seal band	GR-S-010 (10 g)
	GR-S-020 (20 g)
	GR-S-050 (50 g)

# LEFSW Series

Battery-less Absolute (Step Motor 24 VDC)

Dust-tight/Water-jet-proof (IP65 Equivalent)

## Dimensions: In-line Motor

LEFSW16E□-□

/Floor mounting type

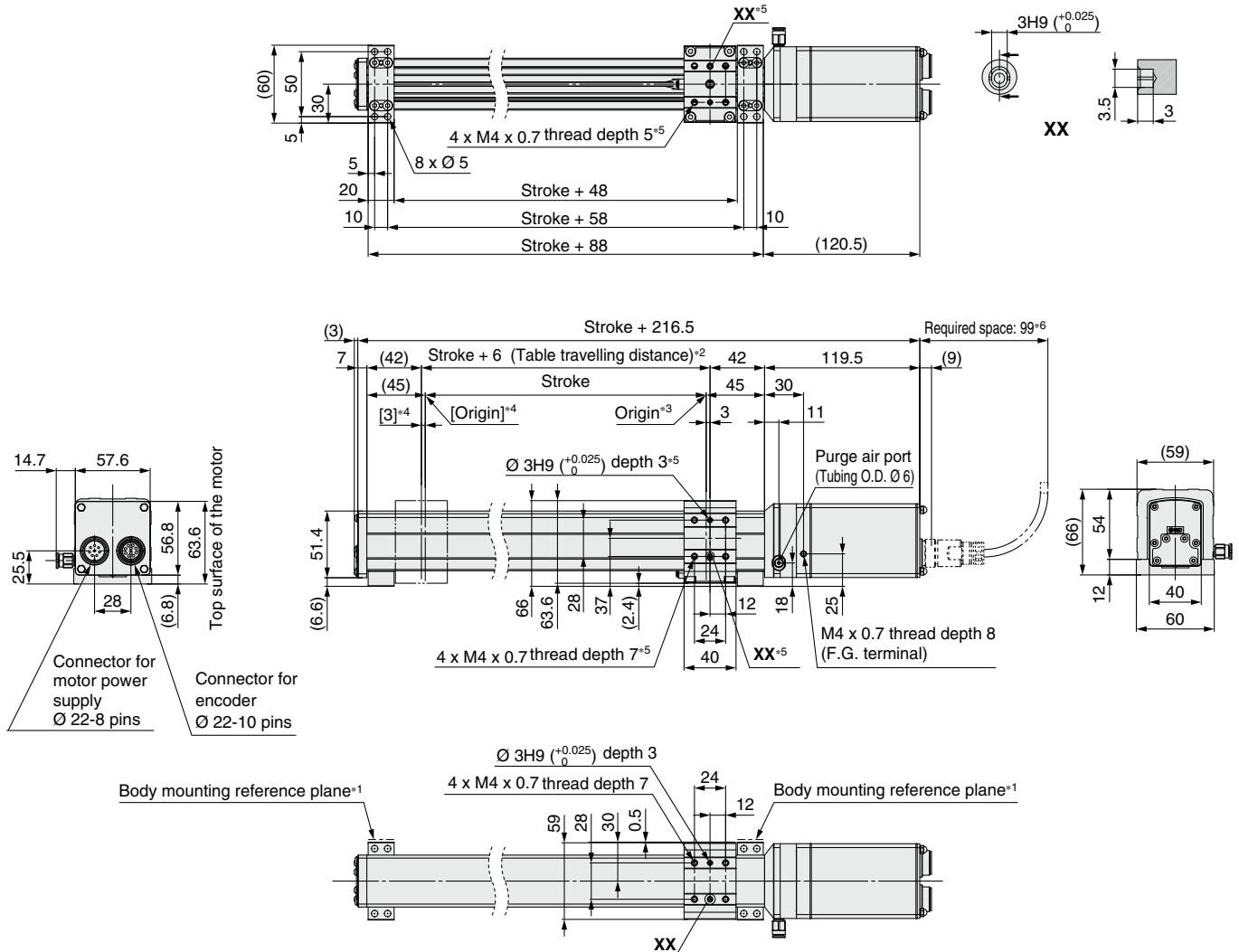

- \*1 When mounting the actuator using the body mounting reference plane, set the height of the opposite surface or pin to be 2 mm or more. (Recommended height: 5 mm)
- \*2 This is the distance within which the table can move when it returns to origin. Make sure that workpieces mounted on the table do not interfere with other workpieces or the facilities around the table.
- \*3 Position after returning to origin
- \*4 [ ] for when the origin position has changed
- \*5 The workpiece mounting method is the same for the opposite surface.
- \*6 The amount of space required to connect the various cables and mount the product  
Provide this amount of space for cable routing.
- \* These drawings are for the floor mounting type. For other types, refer to the operation manual.



## Dimensions: In-line Motor

LEFSW25E□-□

/Floor mounting type

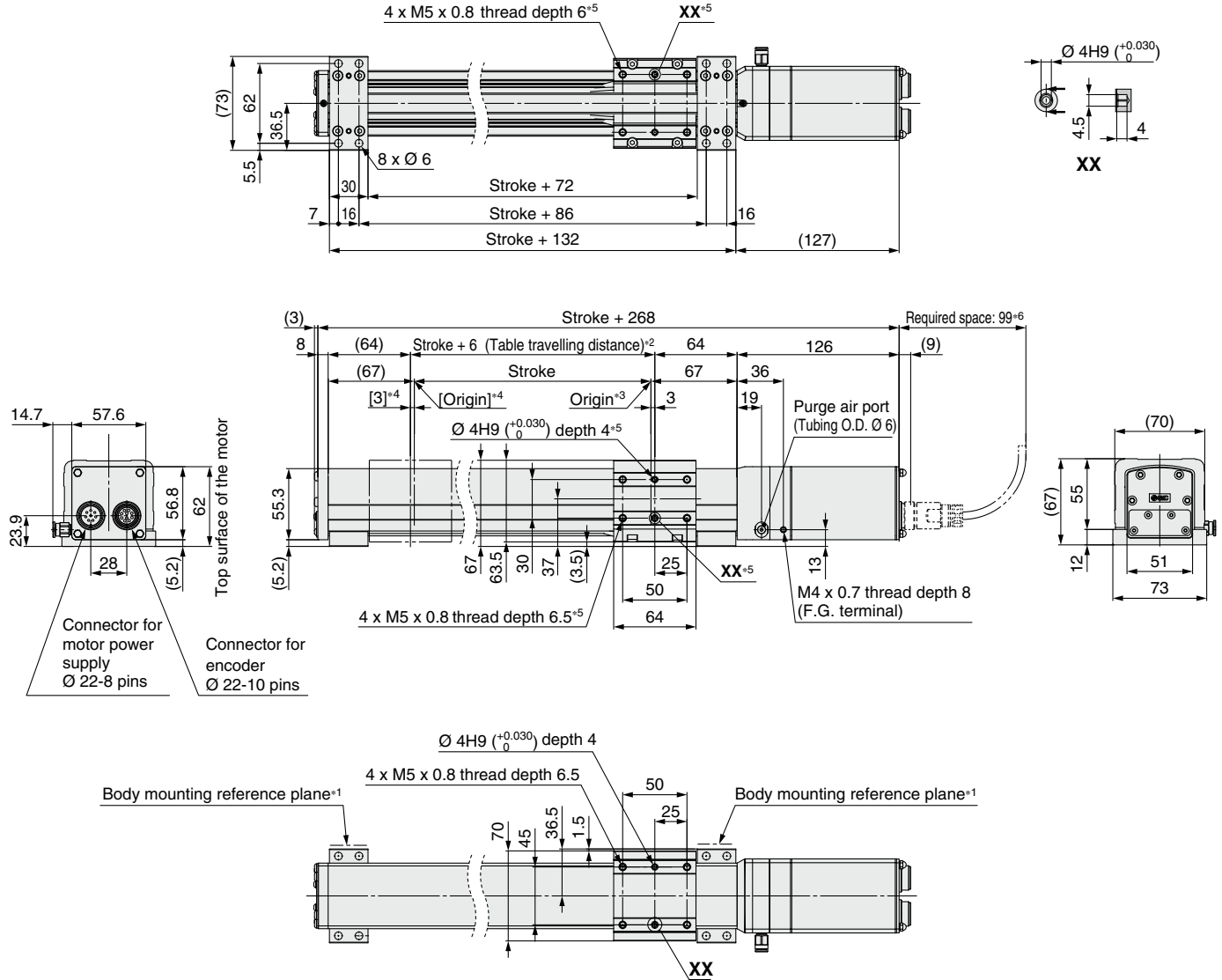

- \*1 When mounting the actuator using the body mounting reference plane, set the height of the opposite surface or pin to be 2 mm or more. (Recommended height: 5 mm)
- \*2 This is the distance within which the table can move when it returns to origin. Make sure that workpieces mounted on the table do not interfere with other workpieces or the facilities around the table.
- \*3 Position after returning to origin
- \*4 [ ] for when the origin position has changed
- \*5 The workpiece mounting method is the same for the opposite surface.
- \*6 The amount of space required to connect the various cables and mount the product  
Provide this amount of space for cable routing.
- \* These drawings are for the floor mounting type. For other types, refer to the operation manual.

# LEFSW Series

Battery-less Absolute (Step Motor 24 VDC)

Dust-tight/Water-jet-proof (IP65 Equivalent)

## Dimensions: In-line Motor

LEFSW32E□-□

/Floor mounting type

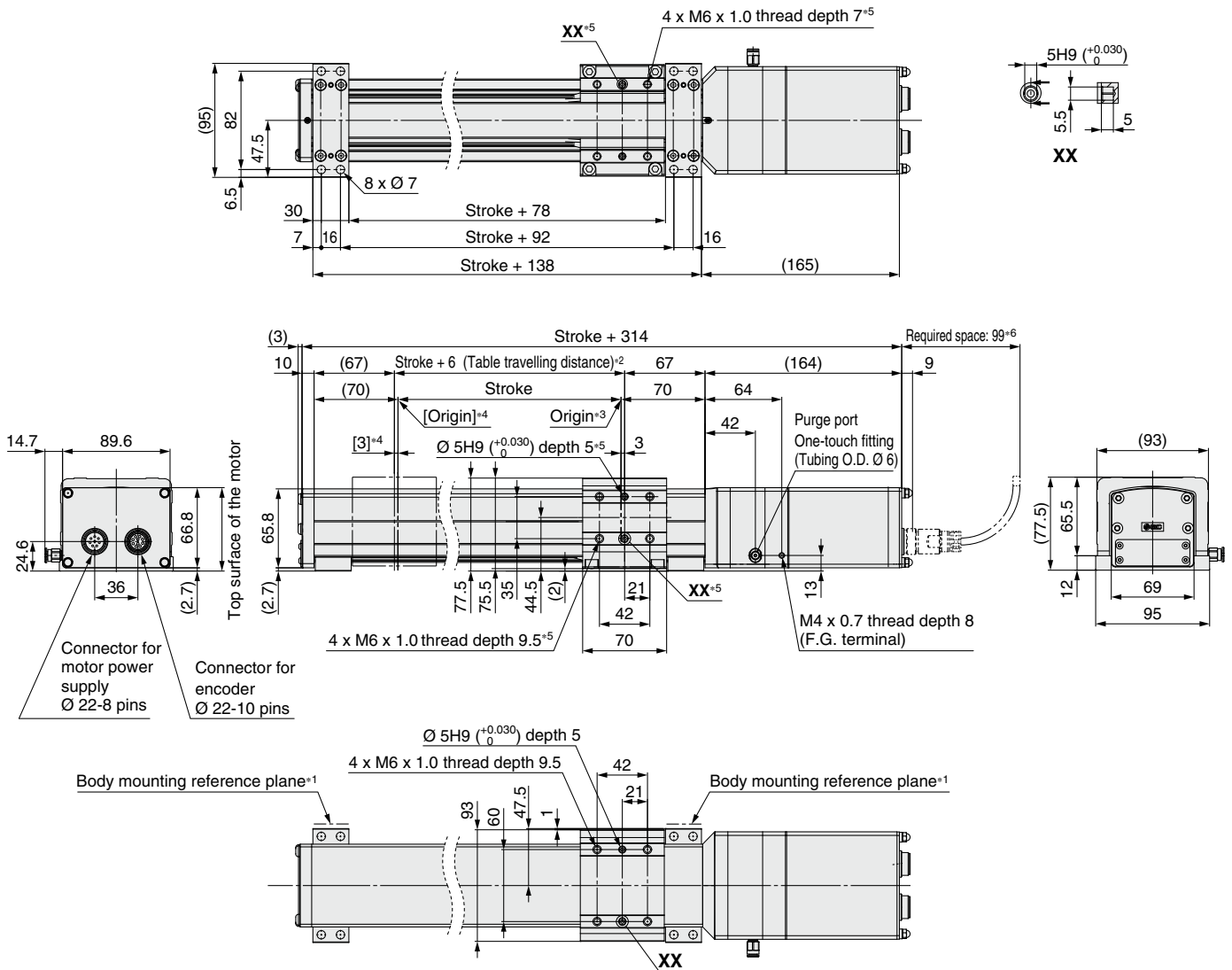

- \*1 When mounting the actuator using the body mounting reference plane, set the height of the opposite surface or pin to be 2 mm or more. (Recommended height: 5 mm)
- \*2 This is the distance within which the table can move when it returns to origin. Make sure that workpieces mounted on the table do not interfere with other workpieces or the facilities around the table.
- \*3 Position after returning to origin
- \*4 [ ] for when the origin position has changed
- \*5 The workpiece mounting method is the same for the opposite surface.
- \*6 The amount of space required to connect the various cables and mount the product  
Provide this amount of space for cable routing.
- \* These drawings are for the floor mounting type. For other types, refer to the operation manual.

## Dimensions: In-line Motor

LEFSW40E□-□

/Floor mounting type

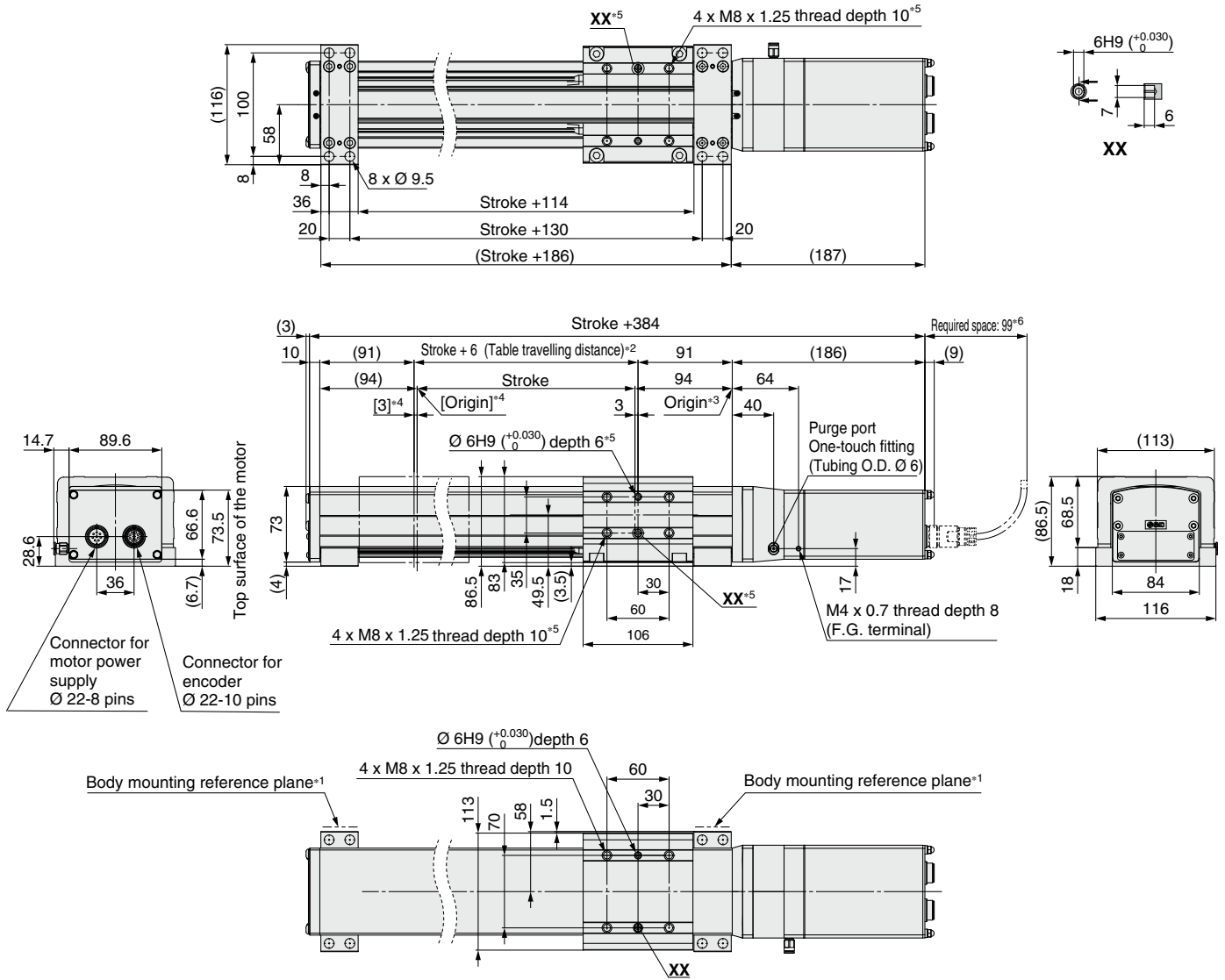

- \*1 When mounting the actuator using the body mounting reference plane, set the height of the opposite surface or pin to be 2 mm or more. (Recommended height: 5 mm)
- \*2 This is the distance within which the table can move when it returns to origin. Make sure that workpieces mounted on the table do not interfere with other workpieces or the facilities around the table.
- \*3 Position after returning to origin
- \*4 [ ] for when the origin position has changed
- \*5 The workpiece mounting method is the same for the opposite surface.
- \*6 The amount of space required to connect the various cables and mount the product  
Provide this amount of space for cable routing.
- \* These drawings are for the floor mounting type. For other types, refer to the operation manual.

# LEFSW Series

Battery-less Absolute (Step Motor 24 VDC)

Dust-tight/Water-jet-proof (IP65 Equivalent)

## Dimensions

### Wall mounting type: LEFSW□E□-□G

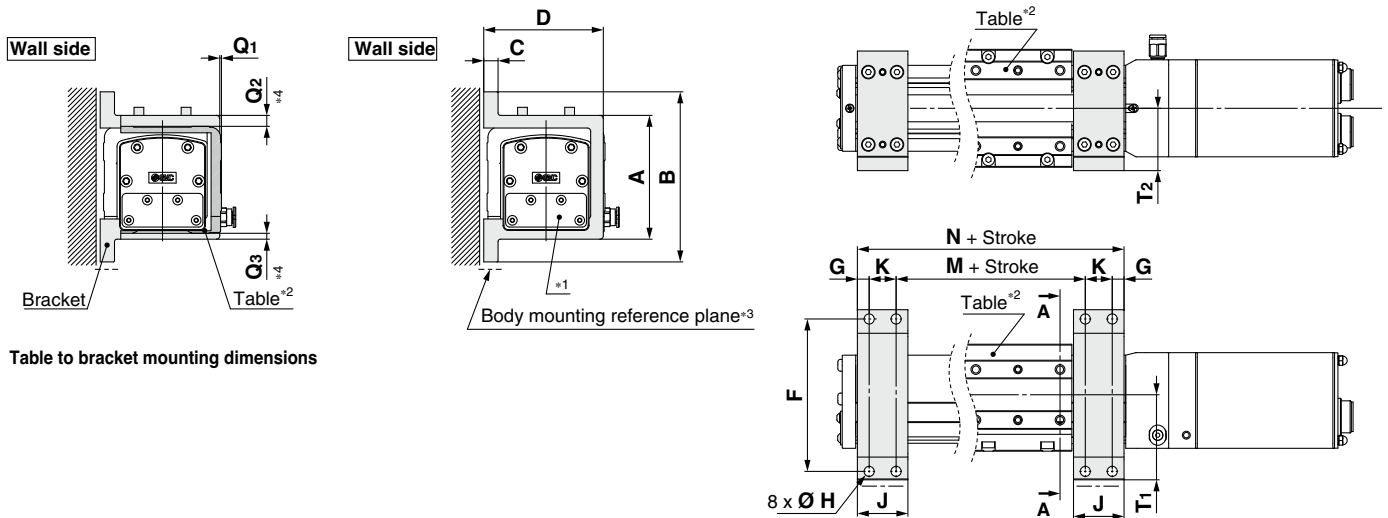

Table to bracket mounting dimensions

### Wall Mounting

Size	A	B	C	D	F	G	Ø H	J	K	M	N	Q <sub>1</sub>	Q <sub>2</sub>	Q <sub>3</sub>	T <sub>1</sub>	T <sub>2</sub>
16	70	94.5	8	60.5	85	5	5	20	10	58	88	0.5	3	3.4	50	31.5
25	73.5	101	8.5	71	90.5	7	6	30	16	86	132	1	6.5	3.5	50.5	37
32	86.5	120	9	94	107.5	7	7	30	16	92	138	1	7	4	63	48.5
40	101.5	143	12	114	125.5	8	9.5	36	20	130	186	1	12.5	6	72.5	58.5

### Ceiling mounting type: LEFSW□E□-□J

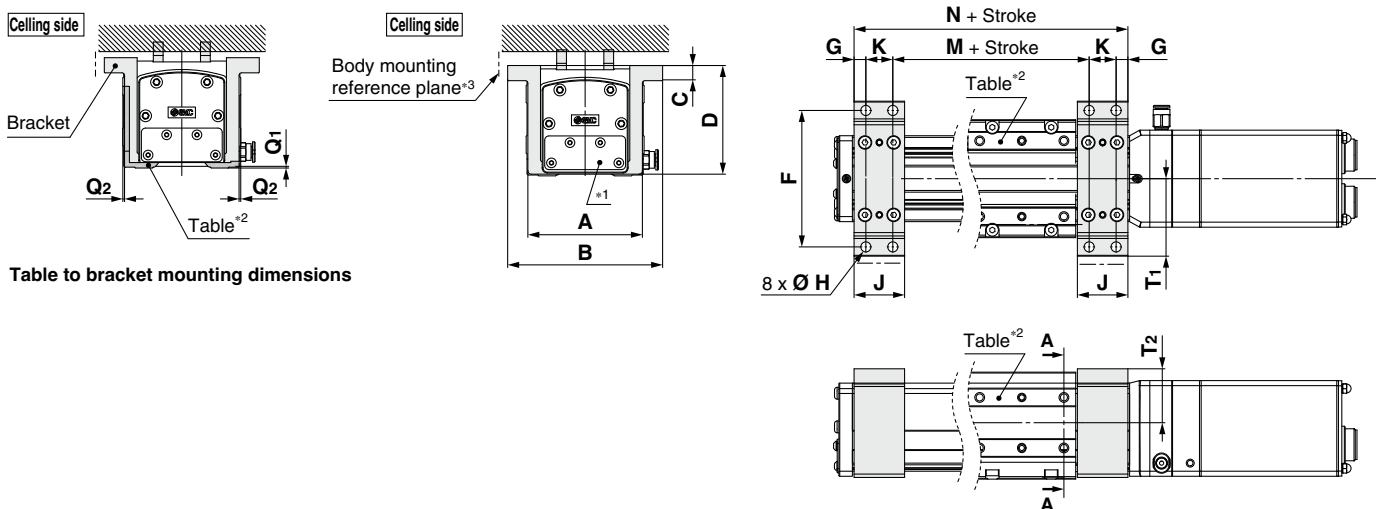

Table to bracket mounting dimensions

### Ceiling Mounting

Size	A	B	C	D	F	G	Ø H	J	K	M	N	Q <sub>1</sub>	Q <sub>2</sub>	T <sub>1</sub>	T <sub>2</sub>
16	57	80	7.4	64	70	5	5	20	10	58	88	1	1	40	30.4
25	68	92	9	64.5	81	7	6	30	16	86	132	1	1	46	32
32	90	119	9	76.5	106	7	7	30	16	92	138	1	1.5	59.5	35
40	107	142	12	83.5	126	8	9.5	36	20	130	186	1.5	3	71	39

\*1 The direction of the actuator body will not change.

\*2 For mounting the table, refer to the operation manual.

\*3 Mount the body mounting reference plane so that the two mounting brackets are in contact with each pin or mating surface.

\*4 For wall mounting, the table for the Q<sub>2</sub> and Q<sub>3</sub> dimensions is located behind the bracket. When mounting the workpiece, be sure to avoid interference.

# LEFSW Series Option

## Actuator Cable (Metal Connector)

### LE-CE-**1**-X4

Cable length (L) [m]

1	1.5
3	3
5	5
8	8*1
A	10*1
B	15*1
C	20*1

\*1 Produced upon receipt of order

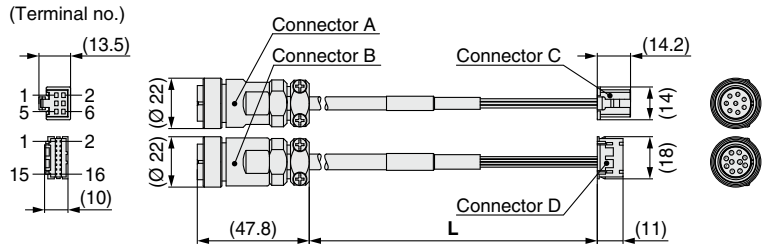

### Weight

Product no.	Weight [g]	Note
LE-CE-1-X4	270	Robotic cable
LE-CE-3-X4	440	
LE-CE-5-X4	650	
LE-CE-8-X4	980	
LE-CE-A-X4	1200	
LE-CE-B-X4	1760	
LE-CE-C-X4	2290	

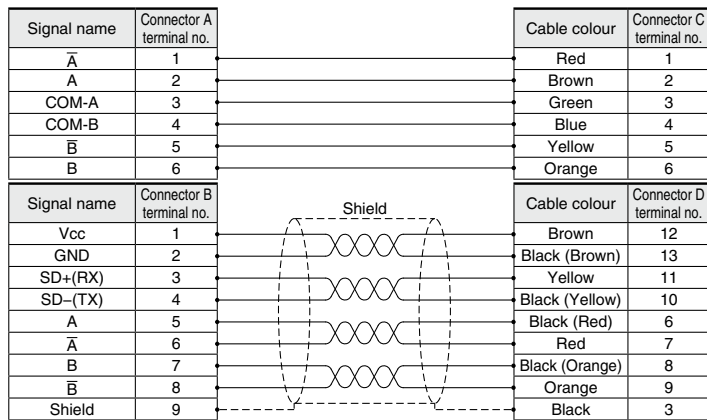



# JXC51/61/E□/9□/P□/D1/L□/M1 Series Precautions Relating to Differences in Controller Versions

As the controller version of the JXC series differs, the internal parameters are not compatible.

- If using the JXC□□-BC, please use the latest version of the JXC-BCW (parameter writing tool).
- There are currently 3 versions available: version 1 products (V1.□ or S1.□), version 2 products (V2.□ or S2.□), and version 3 products (V3.□ or S3.□). Keep in mind that in order to write a backup file (.bcp) to another controller with the JXC-BCW, it needs to be the same version as the controller that created the file. (For example, a backup file created by a version 1 product can only be written to another version 1 product, and so on.)

## Identifying Version Symbols

### JXC□□ Series Version V3.□ or S3.□ Products

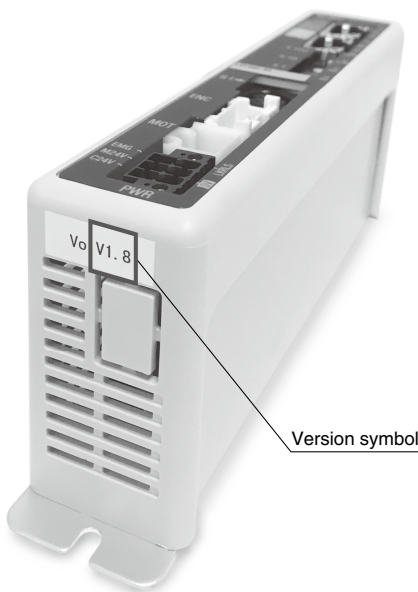

XR V3.0

#### Applicable models

JXC9□□ Series

XR S3.0 T1.0

#### Applicable models

JXC51□ Series  
JXC61□ Series  
JXCE□□ Series  
JXCP□□ Series  
JXCD1□ Series  
JXCL□□ Series  
JXCM1□ Series

### JXC□□ Series Version V2.□ or S2.□ Products

WP V2.1

#### Applicable models

JXC9□□ Series

WP S2.2 T1.1

#### Applicable models

JXCE□□ Series  
JXCP□□ Series  
JXCD1□ Series  
JXCL□□ Series

### JXC□□ Series Version V1.□ or S1.□ Products

XR V1.0

#### Applicable models

JXC9□□ Series

XR S1.0 T1.0

#### Applicable models

JXCE□□ Series  
JXCP□□ Series  
JXCD1□ Series  
JXCL□□ Series

# Precautions Relating to Differences in Controller Versions **JXC51/61/E□/9□/P□/D1/L□/M1 Series**

## Blank Controller Versions and Applicable Actuator Sizes

■ The applicable electric actuator size range differs depending on the controller version.

Be sure to confirm the controller version before using a blank controller.

## Blank Controller Versions/Applicable Electric Actuator Sizes

Blank controller		Applicable electric actuator size											
Series	Controller version	LEFS□E	LEFB□E	LEKFS□E	LEFSW□E	LEY□E	LEY□E-X8	LEYG□E	LES□E	LESH□E	LESYH□E	LER□E	LEHF□E
<b>JXC91□ series</b> <b>JXCD1□ series</b> <b>JXCE1□ series</b> <b>JXCP1□ series</b> <b>JXCL1□ series</b>	Version 3.4 (V3.4, S3.4) Version 3.5 (V3.5, S3.5)	25, 32, 40	25, 32, 40	25, 32, 40	25, 32, 40	25, 32, 40	25, 32, 40	25, 32, 40	25	25	16, 25	50	32, 40
	Version 3.6 (V3.6, S3.6) or higher	16, 25, 32, 40	16, 25, 32, 40	16, 25, 32, 40	16, 25, 32, 40	16, 25, 32, 40		16, 25, 32, 40			16, 25, 32, 40		
<b>JXCM1□ series</b> <b>JXC51/61 series</b>	Version 3.4 (V3.4, S3.4)	25, 32, 40	25, 32, 40	25, 32, 40	25, 32, 40	25, 32, 40		25, 32, 40			25, 32, 40		
	Version 3.5 (V3.5, S3.5) or higher	16, 25, 32, 40	16, 25, 32, 40	16, 25, 32, 40	16, 25, 32, 40	16, 25, 32, 40	16, 25, 32, 40		16, 25, 32, 40	8, 16, 25			
<b>JXC□F series</b>	All versions												



# LEFSW Series Specific Product Precautions 1

Be sure to read this before handling the products. Refer to the back cover for safety instructions. For electric actuator precautions, refer to the “Handling Precautions for SMC Products” and the “Operation Manual” on the SMC website: <https://www.smc.eu>

## Handling

### ⚠ Caution

#### 1. Absolute encoder ID mismatch error at the first connection

In the following cases, an “ID mismatch error” alarm occurs after the power is turned ON. Perform a return to origin operation after resetting the alarm before use.

- When an electric actuator is connected and the power is turned ON for the first time after purchase\*1
- When the actuator or motor is replaced
- When the controller is replaced

\*1 If you have purchased an electric actuator and controller with the set part number, the pairing may have already been completed and the alarm may not be generated.

#### “ID mismatch error”

Operation is enabled by matching the encoder ID on the electric actuator side with the ID registered in the controller. This alarm occurs when the encoder ID is different from the registered contents of the controller. By resetting this alarm, the encoder ID is registered (paired) to the controller again.

When a controller is changed after pairing is completed				
	Encoder ID no. (* Numbers below are examples.)			
Actuator	17623	17623	17623	17623
Controller	17623	17699	17699	17623
ID mismatch error occurred?	No	Yes	Error reset ⇒ No	

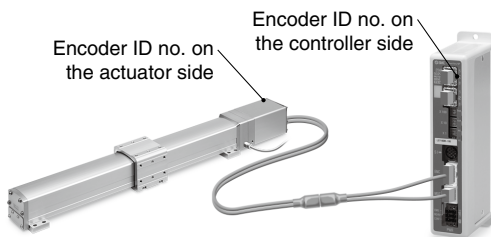

The ID number is automatically checked when the control power supply is turned ON. An error is output if the ID number does not match.

#### 2. In environments where strong magnetic fields are present, use may be limited.

A magnetic sensor is used in the encoder. Therefore, if the actuator motor is used in an environment where strong magnetic fields are present, malfunction or failure may occur. Do not expose the actuator motor to magnetic fields with a magnetic flux density of 1 mT or more.

When installing an electric actuator and an air cylinder with an auto switch (ex. CDQ2 series) or multiple electric actuators side by side, maintain a space of 40 mm or more around the motor. Refer to the construction drawing of the actuator motor.

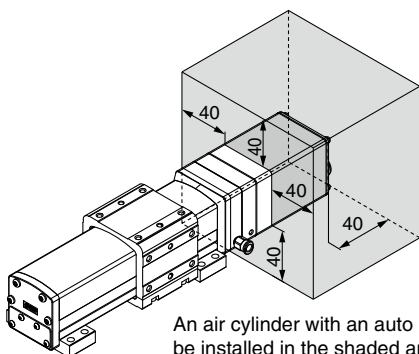

An air cylinder with an auto switch cannot be installed in the shaded area.

#### ● When lining up actuators

SMC actuators can be used with their motors adjacent to each other. However, maintain a space of 40 mm or more between the motors and the position where the magnet passes. The magnet is in the middle of the table.

○ Can be used with their motors adjacent to each other

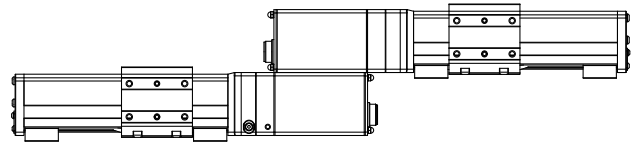

✗ Do not allow the motors to be in close proximity to the position where the magnet passes.

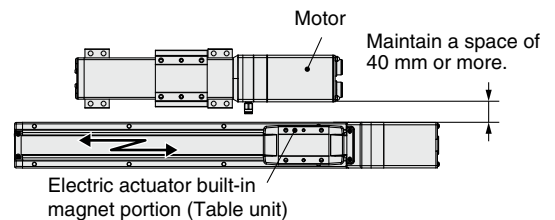
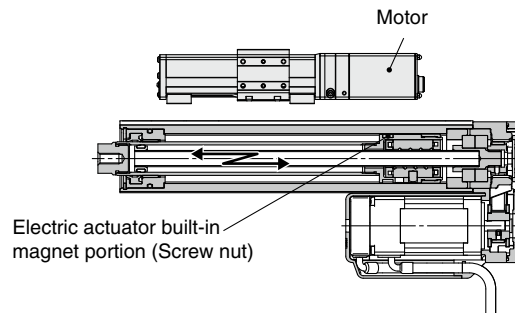





## LEFSW Series

# Specific Product Precautions 2

Be sure to read this before handling the products. Refer to the back cover for safety instructions. For electric actuator precautions, refer to the “Handling Precautions for SMC Products” and the “Operation Manual” on the SMC website: <https://www.smc.eu>

### Handling

#### ⚠ Caution

3. Do not mount the product vertically.

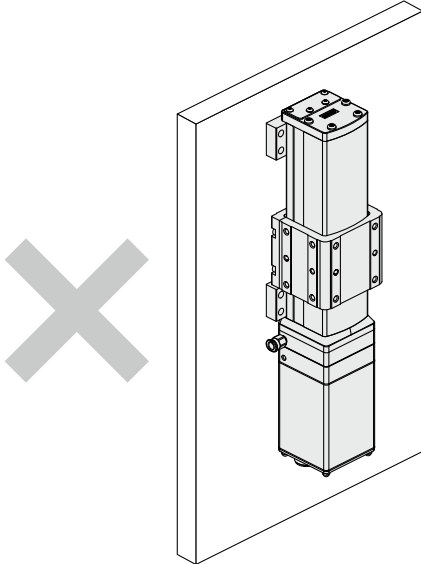

4. For wall or ceiling mounting, select an appropriate mounting bracket.

Do not change the orientation when mounting the floor mounting type.

Lateral-rotation mounting

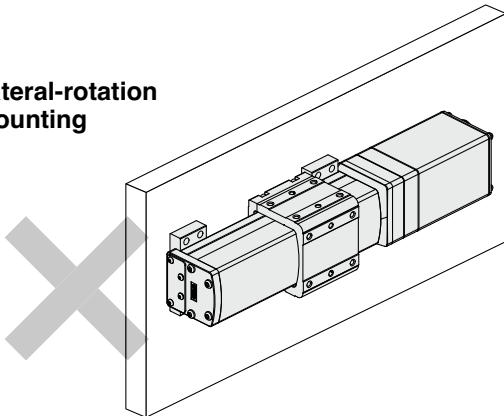

Reverse mounting

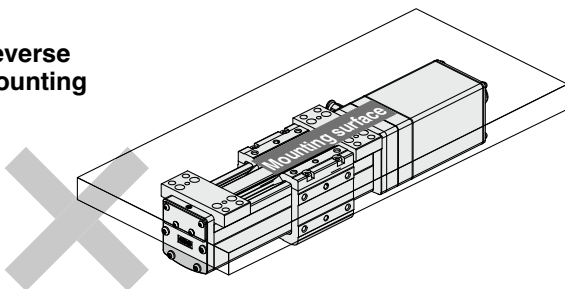

5. When purging, please flow air from the purge air port, flow rate: 20 L/min (ANR). When not in use, close the port with a plug (KQ2P-06).
6. When the product is used where it is exposed to the liquid other than water, protective measure needs to be prepared. In particular, the product cannot be used in environments where oils, such as cutting oil or cutting fluid, are present.
7. In an environment where steam is generated, there is a possibility of abnormal wear due to grease leaking from the seal or rusting of metal parts due to unexpected intrusion into the product interior.
8. Connect all actuator cables to the electric actuator before use. If the actuator cables are not connected, the actuator will not provide a protective structure.
9. The controller and the connectors on the controller side are not covered by IP protection. Take measures to protect them from water and dust.

# CE/UKCA/UL-compliance List

For CE, UKCA, and UL-compliant products, refer to the tables below.

As of April 2023

## ■ Controllers [○]: Compliant [×]: Not compliant

Compatible motor	Series	CE UK CA	cUL <sup>us</sup>	
			Compliance	Certification No. (File No.)
Battery-less absolute (Step motor 24 VDC)	JXC51/61	○	○	E480340
	JXCE1/EF	○	○	
	JXC91/9F	○	○	
	JXCP1/PF	○	○	
	JXCD1	○	○	
	JXCL1/LF	○	○	
	JXCM1	○	○	

## ■ Actuators [○]: Compliant

Compatible motor	Series	CE UK CA	cUL <sup>us</sup>	
			Compliance	Certification No. (File No.)
Battery-less absolute (Step motor 24 VDC)	LEFSW	○	N/A	—

\* If the actuator is ordered separately, it does not comply with UL standards.

## Safety Instructions

These safety instructions are intended to prevent hazardous situations and/or equipment damage. These instructions indicate the level of potential hazard with the labels of “Caution,” “Warning” or “Danger.” They are all important notes for safety and must be followed in addition to International Standards (ISO/IEC) <sup>1)</sup>, and other safety regulations.

### Danger:

**Danger** indicates a hazard with a high level of risk which, if not avoided, will result in death or serious injury.

### Warning:

**Warning** indicates a hazard with a medium level of risk which, if not avoided, could result in death or serious injury.

### Caution:

**Caution** indicates a hazard with a low level of risk which, if not avoided, could result in minor or moderate injury.

- 1) ISO 4414: Pneumatic fluid power – General rules and safety requirements for systems and their components.
- ISO 4413: Hydraulic fluid power – General rules and safety requirements for systems and their components.
- IEC 60204-1: Safety of machinery – Electrical equipment of machines. (Part 1: General requirements)
- ISO 10218-1: Robots and robotic devices - Safety requirements for industrial robots - Part 1: Robots.
- etc.

## Warning

### 1. The compatibility of the product is the responsibility of the person who designs the equipment or decides its specifications.

Since the product specified here is used under various operating conditions, its compatibility with specific equipment must be decided by the person who designs the equipment or decides its specifications based on necessary analysis and test results. The expected performance and safety assurance of the equipment will be the responsibility of the person who has determined its compatibility with the product. This person should also continuously review all specifications of the product referring to its latest catalogue information, with a view to giving due consideration to any possibility of equipment failure when configuring the equipment.

### 2. Only personnel with appropriate training should operate machinery and equipment.

The product specified here may become unsafe if handled incorrectly. The assembly, operation and maintenance of machines or equipment including our products must be performed by an operator who is appropriately trained and experienced.

### 3. Do not service or attempt to remove product and machinery/equipment until safety is confirmed.

1. The inspection and maintenance of machinery/equipment should only be performed after measures to prevent falling or runaway of the driven objects have been confirmed.
2. When the product is to be removed, confirm that the safety measures as mentioned above are implemented and the power from any appropriate source is cut, and read and understand the specific product precautions of all relevant products carefully.
3. Before machinery/equipment is restarted, take measures to prevent unexpected operation and malfunction.

### 4. Our products cannot be used beyond their specifications. Our products are not developed, designed, and manufactured to be used under the following conditions or environments.

**Use under such conditions or environments is not covered.**

1. Conditions and environments outside of the given specifications, or use outdoors or in a place exposed to direct sunlight.
2. Use for nuclear power, railways, aviation, space equipment, ships, vehicles, military application, equipment affecting human life, body, and property, fuel equipment, entertainment equipment, emergency shut-off circuits, press clutches, brake circuits, safety equipment, etc., and use for applications that do not conform to standard specifications such as catalogues and operation manuals.
3. Use for interlock circuits, except for use with double interlock such as installing a mechanical protection function in case of failure. Please periodically inspect the product to confirm that the product is operating properly.

## Caution

**We develop, design, and manufacture our products to be used for automatic control equipment, and provide them for peaceful use in manufacturing industries.**

**Use in non-manufacturing industries is not covered.**

Products we manufacture and sell cannot be used for the purpose of transactions or certification specified in the Measurement Act.

The new Measurement Act prohibits use of any unit other than SI units in Japan.

## Limited warranty and Disclaimer/Compliance Requirements

The product used is subject to the following “Limited warranty and Disclaimer” and “Compliance Requirements”. Read and accept them before using the product.

### Limited warranty and Disclaimer

1. The warranty period of the product is 1 year in service or 1.5 years after the product is delivered, whichever is first. <sup>2)</sup> Also, the product may have specified durability, running distance or replacement parts. Please consult your nearest sales branch.
2. For any failure or damage reported within the warranty period which is clearly our responsibility, a replacement product or necessary parts will be provided. This limited warranty applies only to our product independently, and not to any other damage incurred due to the failure of the product.
3. Prior to using SMC products, please read and understand the warranty terms and disclaimers noted in the specified catalogue for the particular products.
- 2) Vacuum pads are excluded from this 1 year warranty.  
A vacuum pad is a consumable part, so it is warranted for a year after it is delivered. Also, even within the warranty period, the wear of a product due to the use of the vacuum pad or failure due to the deterioration of rubber material are not covered by the limited warranty.

### Compliance Requirements

1. The use of SMC products with production equipment for the manufacture of weapons of mass destruction (WMD) or any other weapon is strictly prohibited.
2. The exports of SMC products or technology from one country to another are governed by the relevant security laws and regulations of the countries involved in the transaction. Prior to the shipment of a SMC product to another country, assure that all local rules governing that export are known and followed.

## Safety Instructions

Be sure to read “Handling Precautions for SMC Products” (M-E03-3) before using.

## SMC Corporation (Europe)

<b>Austria</b>	+43 (0)2262622800	www.smc.at	office@smc.at
<b>Belgium</b>	+32 (0)33551464	www.smc.be	info@smc.be
<b>Bulgaria</b>	+359 (0)2807670	www.smc.bg	office@smc.bg
<b>Croatia</b>	+385 (0)13707288	www.smc.hr	office@smc.hr
<b>Czech Republic</b>	+420 541424611	www.smc.cz	office@smc.cz
<b>Denmark</b>	+45 70252900	www.smc.dk.com	smc@smcdk.com
<b>Estonia</b>	+372 651 0370	www.smcee.ee	info@smcee.ee
<b>Finland</b>	+358 207513513	www.smc.fi	smc.fi@smc.fi
<b>France</b>	+33 (0)164761000	www.smc-france.fr	supportclient@smc-france.fr
<b>Germany</b>	+49 (0)61034020	www.smc.de	info@smc.de
<b>Greece</b>	+30 210 2717265	www.smchellas.gr	sales@smchellas.gr
<b>Hungary</b>	+36 23513000	www.smc.hu	office@smc.hu
<b>Ireland</b>	+353 (0)14039000	www.smcautomation.ie	sales@smcautomation.ie
<b>Italy</b>	+39 03990691	www.smcitalia.it	mailbox@smcitalia.it
<b>Latvia</b>	+371 67817700	www.smc.lv	info@smc.lv

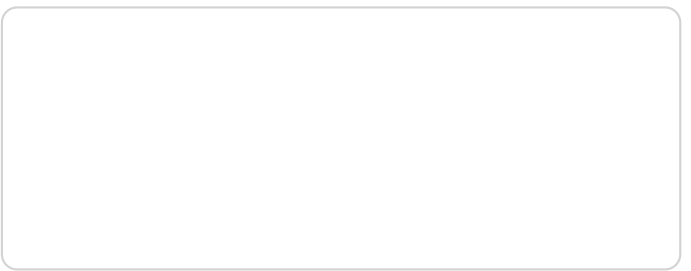

<b>Lithuania</b>	+370 5 2308118	www.smclt.lt	info@smclt.lt
<b>Netherlands</b>	+31 (0)205318888	www.smc.nl	info@smc.nl
<b>Norway</b>	+47 67129020	www.smc-norge.no	post@smc-norge.no
<b>Poland</b>	+48 222119600	www.smc.pl	sales@smc.pl
<b>Portugal</b>	+351 214724500	www.smc.eu	apoioclientept@smc.smces.es
<b>Romania</b>	+40 213205111	www.smcromania.ro	smcromania@smcromania.ro
<b>Russia</b>	+7 (812)3036600	www.smc.eu	sales@smcru.com
<b>Slovakia</b>	+421 (0)413213212	www.smc.sk	office@smc.sk
<b>Slovenia</b>	+386 (0)73885412	www.smc.si	office@smc.si
<b>Spain</b>	+34 945184100	www.smc.eu	post@smc.smces.es
<b>Sweden</b>	+46 (0)86031240	www.smc.nu	smc@smc.nu
<b>Switzerland</b>	+41 (0)523963131	www.smc.ch	info@smc.ch
<b>Turkey</b>	+90 212 489 0 440	www.smcturkey.com.tr	info@smcturkey.com.tr
<b>UK</b>	+44 (0)845 121 5122	www.smc.uk	sales@smc.uk
<b>South Africa</b>	+27 10 900 1233	www.smcza.co.za	zasales@smcza.co.za