

Electric Actuator

High Performance Slider Type

New



— For details, refer to page 57 and onward. —

Battery-less Absolute (Step Motor 24 VDC)



Reduces cycle time

Cycle time

Reduced by **39 %** (0.93 s → 0.57 s)
compared with the existing model*¹

*¹ When LEFS25GH-400 is operated from 0 to 400 mm

Acceleration/
Deceleration

10000 mm/s²
(334 % increase compared with the existing model)

Max. speed

1500 mm/s
(Improved by 25 % compared with the existing model)

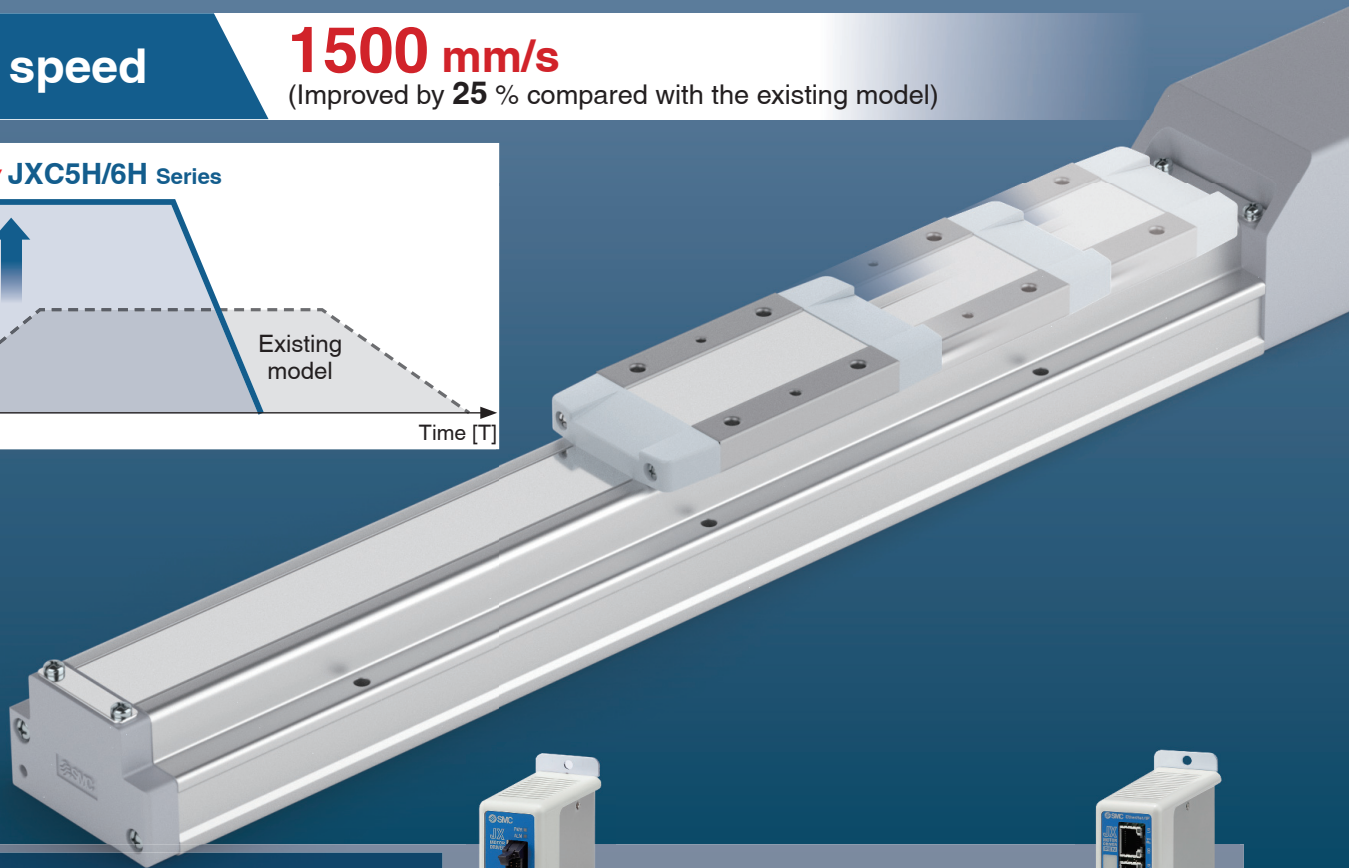
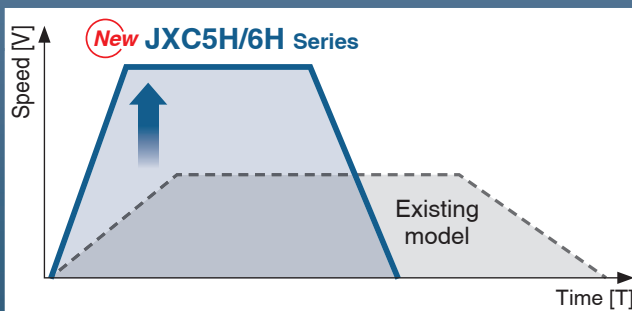

High Performance
Step Motor Controller

Higher acceleration and maximum speed can be set with the special controller (for LEFS□G Series).

Parallel I/O

JXC5H/6H Series p. 43



EtherCAT/EtherNet/IP™/
PROFINET

JXCEH/9H/PH Series p. 50



LEFS□G Series



CAT.EUS100-148A-UK

Battery-less absolute encoder compatible

Easy operation restart after recovery of the power supply

The battery-less absolute encoder mounted on the motor retains position information at all times, regardless of whether the control power supply is ON or OFF. A return to origin operation is not necessary when the power supply is recovered.

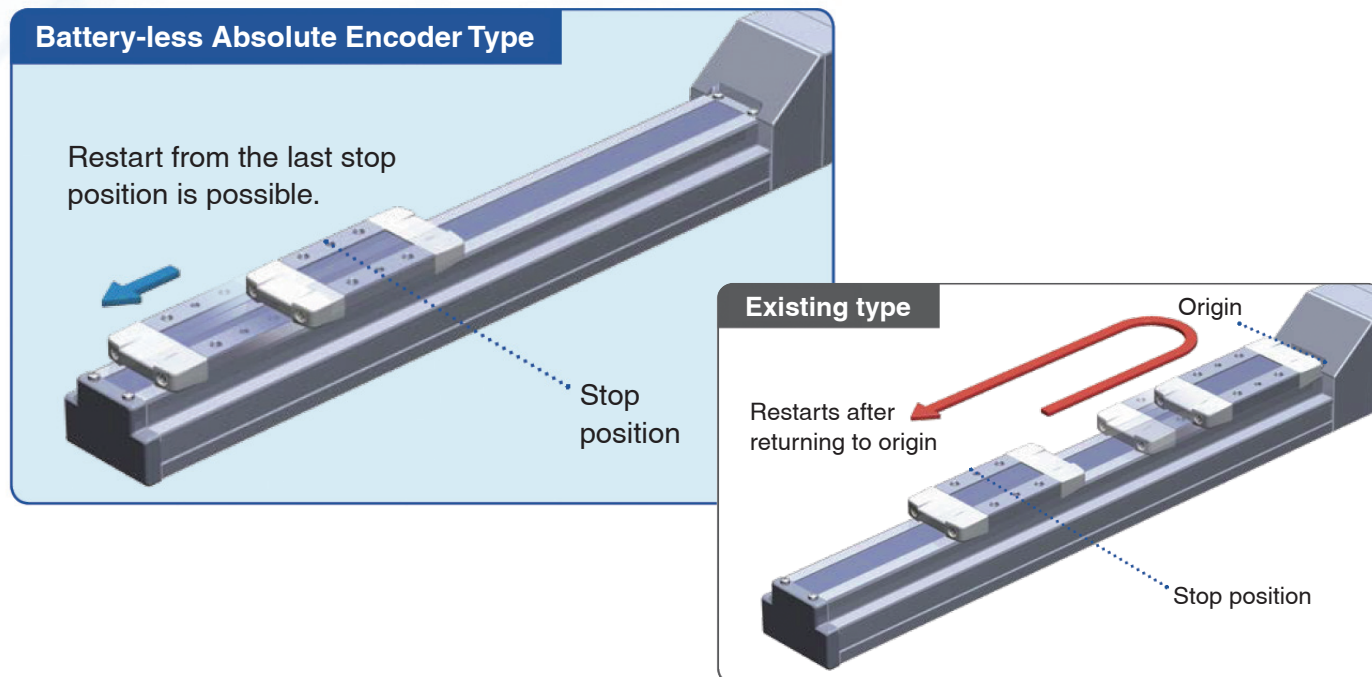

Maintenance labour can be reduced as the product does not require the use of batteries.

Batteries are not required to store the position information. Therefore, there is no need to store spare batteries or to recycle and replace dead batteries.



Step Data Input Type **JXC5H/6H Series** p. 43



Simple setting allows for immediate use!

“Easy Mode” for simple setting

For immediate use, select “Easy Mode.”

Step motor
(Servo/24 VDC)

JXC5H/6H

<When a PC is used> Controller setting software

- Step data setting, test drive, jogging, and move for the constant rate can be set and operated on one screen.

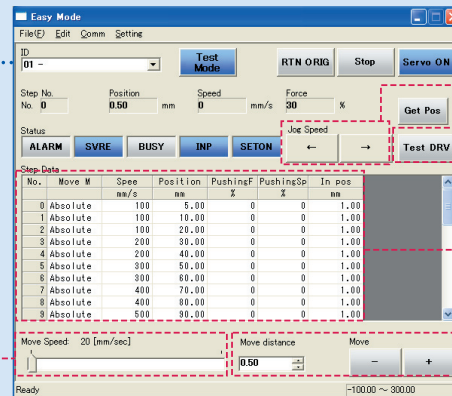
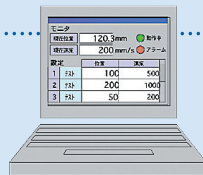

Annotations for the software screenshot:

- Jogging
- Start testing
- Step data setting
- Move for the constant rate
- Setting of jog and speed of the constant rate

<When a TB (teaching box) is used>

- The simple screen without scrolling promotes ease of setting and operation.
- Choose an icon from the first screen to select a function.
- Set the step data and check the monitor on the second screen.



Example of setting the step data

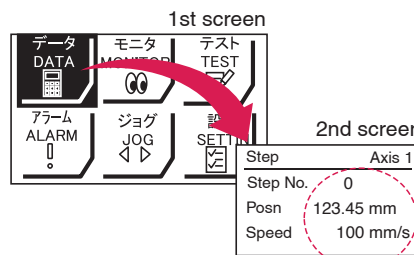

After entering the values, they can be registered by pressing “SET.”

Example of checking the operation status

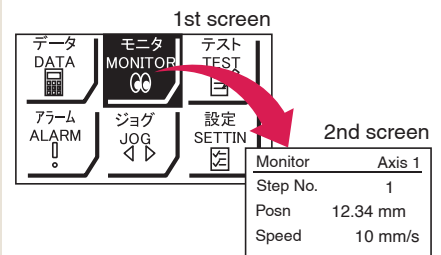

The operation status can be checked.

Teaching box screen

- Data can be set by inputting only the position and speed. (Other conditions are preset.)

| Step | Axis 1 |
|----------|----------|
| Step No. | 0 |
| Posn | 50.00 mm |
| Speed | 200 mm/s |



| Step | Axis 1 |
|----------|----------|
| Step No. | 1 |
| Posn | 80.00 mm |
| Speed | 100 mm/s |

Step Data Input Type **JXC5H/6H** Series

⊙ “Normal Mode” for detailed setting

Select “Normal Mode” when detailed setting is required.

- Step data can be set in detail.
- Parameters can be set.
- Signals and terminal status can be monitored.
- JOG and constant rate movement, return to origin, test drive, and testing of forced output can be performed.

<When a PC is used>
Controller setting software

- Step data setting, parameter setting, monitoring, teaching, etc., are displayed in different windows.

The screenshot shows four windows from the controller setting software:

- Step data setting window:** A table with columns: No., Move M, Speed, Position, Accel, Decel, Pushing. It lists 10 absolute move steps with various speeds and positions.
- Parameter setting window:** A table with columns: Item, Value. It lists parameters like Controller ID, IO pattern, and Max speed.
- Monitoring window:** A control panel with buttons for IN 1-5, DRIVE, RESET, SYON, OUT 1-5, BUSY, AREA, and a status display.
- Teaching window:** A panel for JOG control, including buttons for JOG, DIRECT, and a speed input field.

<When a TB (teaching box) is used>

- Multiple step data can be stored in the teaching box and transferred to the controller.
- Continuous test drive by up to 5 step data

Teaching box screen

- Each function (step data setting, test drive, monitoring, etc.) can be selected from the main menu.

The diagram shows the navigation flow on the teaching box screen:

- Main menu screen:** Options for Step data, Parameter, and Test.
- Step data setting screen:** Fields for Step No. (0), Movement MOD, and Posn (123.45 mm).
- Test screen:** Options for Test DRV and Stop.
- Monitoring screen:** Status for Out mon (BUSY, SVRE, SETON) and Axis 1.

The actuator and controller are provided as a set. (They can be ordered separately as well.)

Confirm that the combination of the controller and actuator is correct.
<Check the following before use.>

- ① Check the actuator label for the model number. This number should match that of the controller.
- ② Check that the Parallel I/O configuration matches (NPN or PNP).

The images show the physical components with their labels:

- Actuator:** A long metal rail with a label **LEFS25GB-400** and **SMC JAPAN**.
- Controller:** A vertical blue and white unit with a label **LEFS25GB-400** and **NPN**.

Function

| Item | Step data input type JXC5H/6H |
|---------------------------------|---|
| Step data and parameter setting | <ul style="list-style-type: none"> Input from controller setting software (PC) Input from teaching box |
| Step data “position” setting | <ul style="list-style-type: none"> Numerical value input from controller setting software (PC) or teaching box Input numerical value Direct teaching JOG teaching |
| Number of step data | 64 points |
| Operation command (I/O signal) | Step No. [IN [*]] input ⇒ [DRIVE] input |
| Completion signal | [INP] output |

Setting Items

TB: Teaching box PC: Controller setting software

| Item | | Contents | Easy Mode | | Normal Mode | Step data input type JXC5H/6H |
|--------------------------------|---------------------------|---|-----------|----|-----------------------------|--|
| | | | TB | PC | TB/PC | |
| Step data setting (Excerpt) | Movement MOD | Selection of “absolute position” and “relative position” | △ | ● | ● | Set at ABS/INC |
| | Speed | Transfer speed | ● | ● | ● | Set in units of 1 mm/s |
| | Position | [Position]: Target position [Pushing]: Pushing start position | ● | ● | ● | Set in units of 0.01 mm |
| | Acceleration/Deceleration | Acceleration/deceleration during movement | ● | ● | ● | Set in units of 1 mm/s ² |
| | Pushing force | Rate of force during pushing operation | ● | ● | ● | Set in units of 1 % |
| | Trigger LV | Target force during pushing operation | △ | ● | ● | Set in units of 1 % |
| | Pushing speed | Speed during pushing operation | △ | ● | ● | Set in units of 1 mm/s |
| | Moving force | Force during positioning operation | △ | ● | ● | Set to 100 % |
| | Area output | Conditions for area output signal to turn ON | △ | ● | ● | Set in units of 0.01 mm |
| | In position | [Position]: Width to the target position [Pushing]: How much it moves during pushing | △ | ● | ● | Set to 0.5 mm or more (Units: 0.01 mm) |
| Parameter setting (Excerpt) | Stroke (+) | + side position limit | X | X | ● | Set in units of 0.01 mm |
| | Stroke (-) | - side position limit | X | X | ● | Set in units of 0.01 mm |
| | ORIG direction | Direction of the return to origin can be set. | X | X | ● | Compatible |
| | ORIG speed | Speed during return to origin | X | X | ● | Set in units of 1 mm/s |
| | ORIG ACC | Acceleration during return to origin | X | X | ● | Set in units of 1 mm/s ² |
| Test | JOG | | ● | ● | ● | Continuous operation at the set speed can be tested while the switch is being pressed. |
| | MOVE | | X | ● | ● | Operation at the set distance and speed from the current position can be tested. |
| | Return to ORIG | | ● | ● | ● | Compatible |
| | Test drive | Operation of the specified step data | ● | ● | ● (Continuous operation) | Compatible |
| | Forced output | ON/OFF of the output terminal can be tested. | X | X | ● | Compatible |
| Monitor | DRV mon | Current position, speed, force, and the specified step data can be monitored. | ● | ● | ● | Compatible |
| | In/Out mon | Current ON/OFF status of the input and output terminal can be monitored. | X | X | ● | Compatible |
| ALM | Status | Alarm currently being generated can be confirmed. | ● | ● | ● | Compatible |
| | ALM Log record | Alarms generated in the past can be confirmed. | X | X | ● | Compatible |
| File | Save/Load | Step data and parameters can be saved, forwarded, and deleted. | X | X | ● | Compatible |
| Other | Language | Can be changed to Japanese or English | ● | ● | ● | Compatible |

△: Can be set from TB Ver. 2.** (The version information is displayed on the initial screen.)

Fieldbus Network

EtherCAT/EtherNet/IP™/PROFINET

Direct Input Type

Step Motor Controller/JXC□ Series p. 50



⊙ **Two types of operation command**

Step no. defined operation: Operate using the preset step data in the controller.

Numerical data defined operation: The actuator operates using values such as position and speed from the PLC.

⊙ **Numerical monitoring available**

Numerical information, such as the current speed, current position, and alarm codes, can be monitored on the PLC.

⊙ **Transition wiring of communication cables**

Two communication ports are provided.

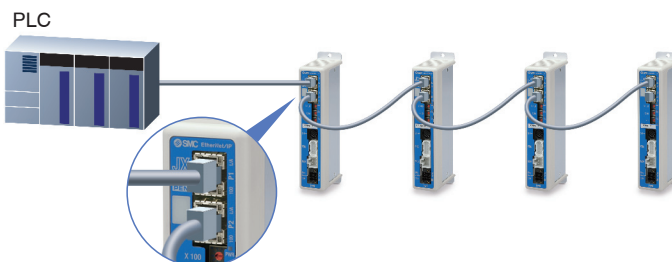

Application

Communication protocols



Both air and electric systems can be established under the same protocol.

Electric Actuators

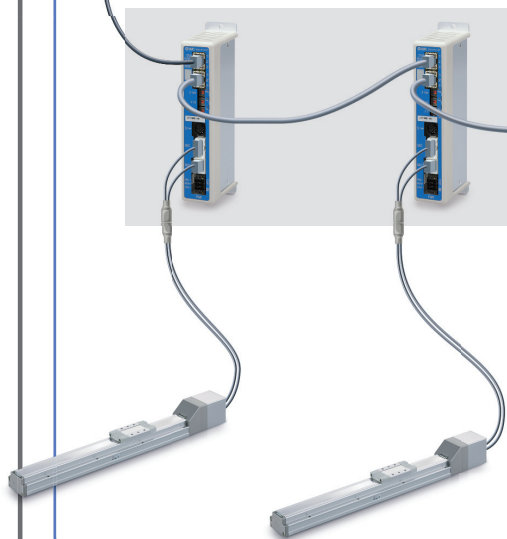

Air Cylinders

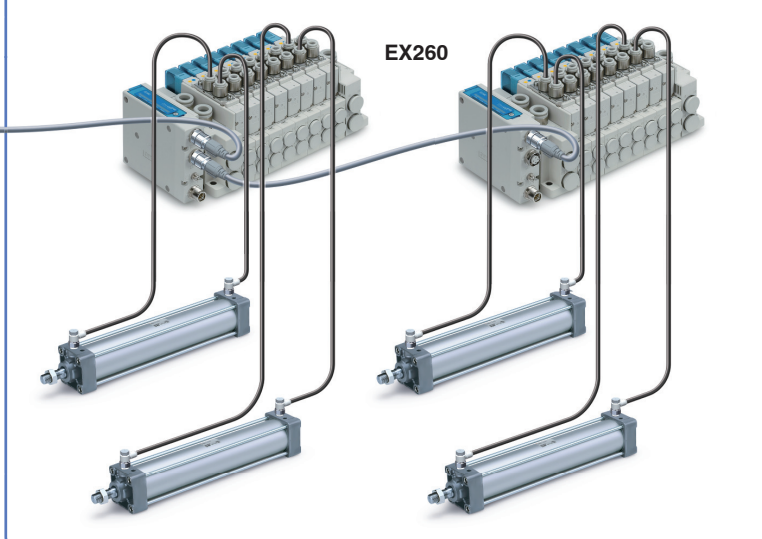

System Construction/General Purpose I/O

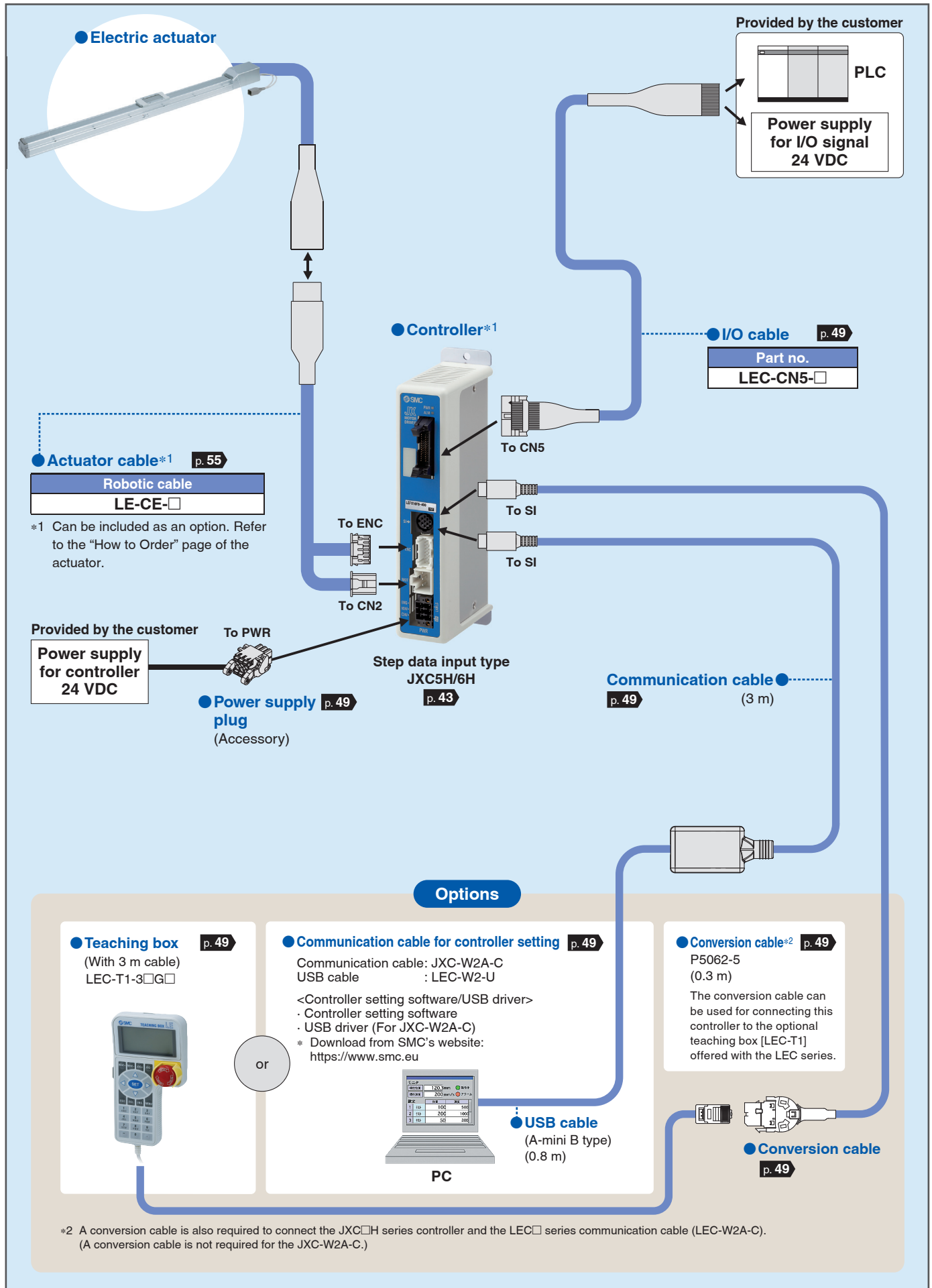

System Construction/Fieldbus Network (EtherCAT/EtherNet/IP™/PROFINET Direct Input Type)

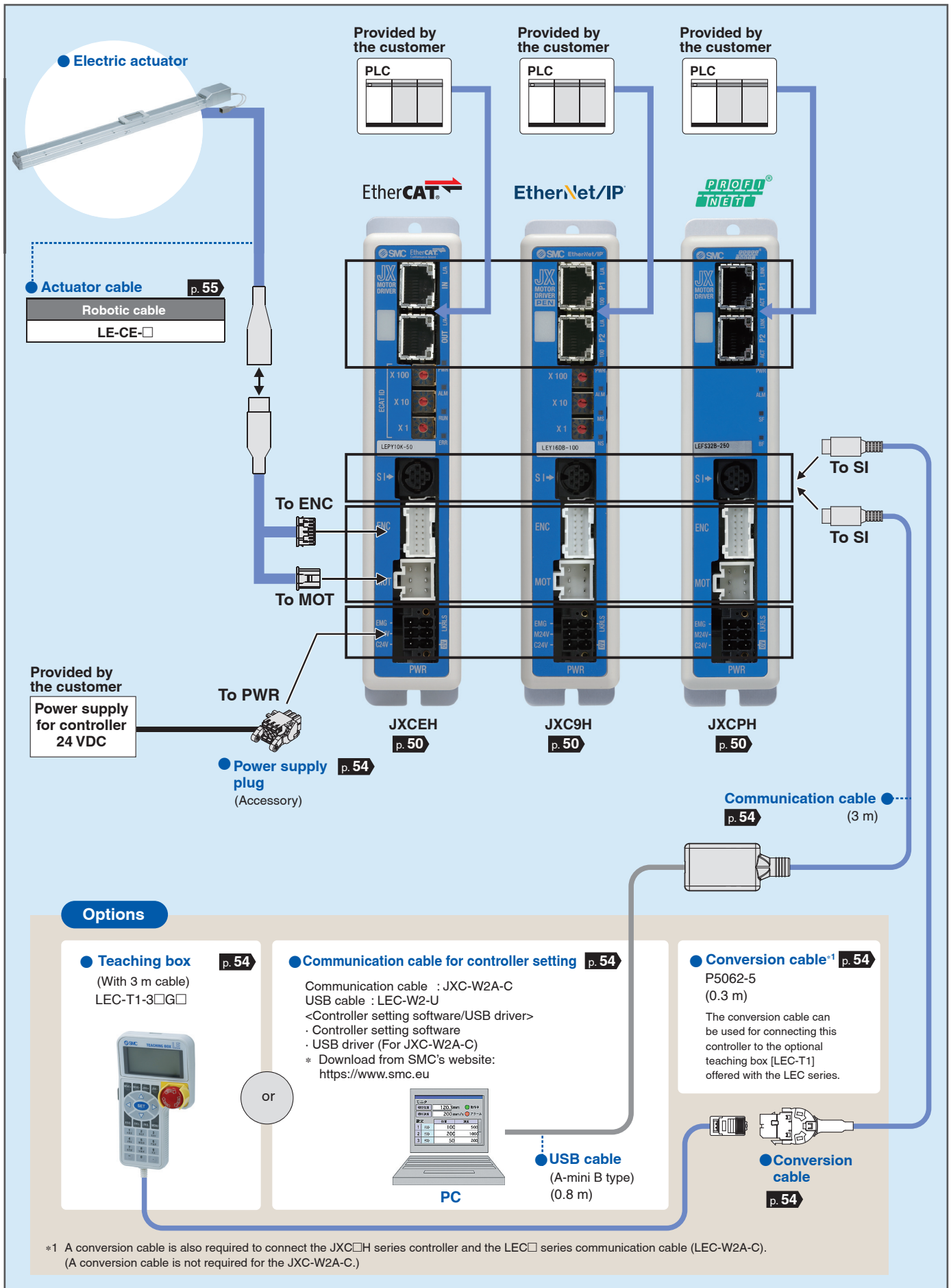

Electric Actuator

High Performance Slider Type

Slider Type/Ball Screw Drive LEFS□G Series

Battery-less Absolute (Step Motor 24 VDC)

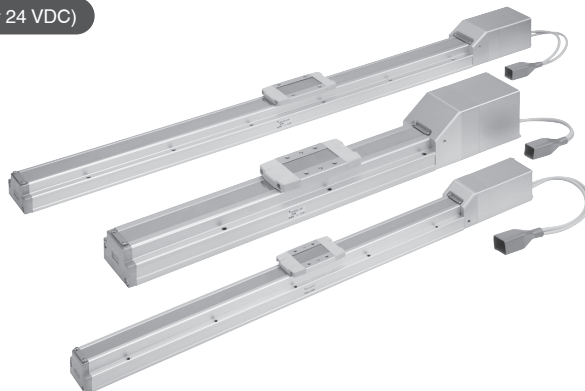

CONTENTS

High Performance Slider Type/Ball Screw Drive LEFS□G Series p. 8

Battery-less Absolute (Step Motor 24 VDC)

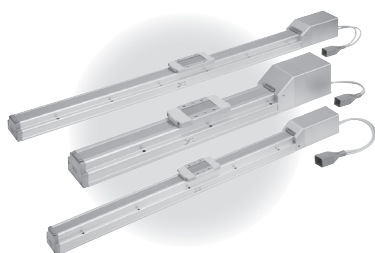

| | |
|----------------------------|-------|
| Model Selection | p. 9 |
| How to Order | p. 17 |
| Specifications | p. 19 |
| Dimensions | p. 21 |
| Auto Switch Mounting | p. 37 |

Controllers JXC□H Series p. 42

High Performance Controller (Step Data Input Type) JXC5H/6H Series Battery-less Absolute (Step Motor 24 VDC)



| | |
|----------------------|-------|
| How to Order | p. 43 |
| Specifications | p. 43 |
| Dimensions | p. 45 |
| Options | p. 49 |
| Actuator Cable | p. 55 |

High Performance Step Motor Controller JXCEH/9H/PH Series Battery-less Absolute (Step Motor 24 VDC)



| | |
|----------------------|-------|
| How to Order | p. 50 |
| Specifications | p. 51 |
| Dimensions | p. 52 |
| Options | p. 54 |
| Actuator Cable | p. 55 |

Battery-less Absolute Encoder Type Specific Product Precautions

p. 56

CE/UKCA/UL-compliance List

p. 57

Model Selection

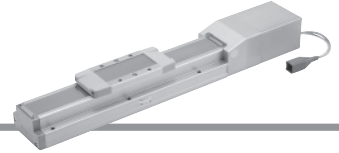

Selection Procedure

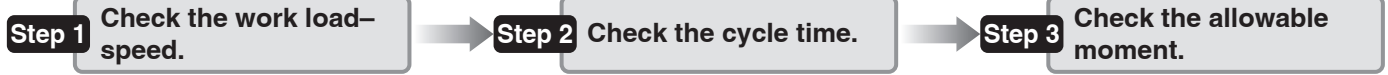

Selection Example

Operating conditions

- Workpiece mass: 10 [kg]
- Speed: 300 [mm/s]
- Acceleration/Deceleration: 10000 [mm/s²]
- Stroke: 200 [mm]
- Mounting orientation: Horizontal upward
- Workpiece mounting condition:

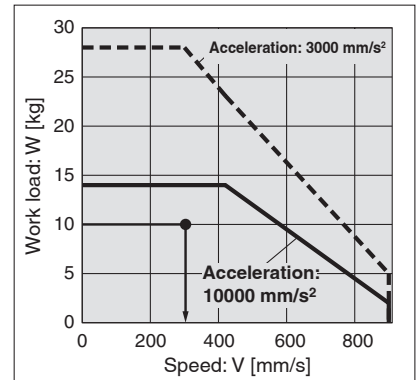
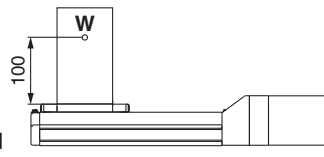

<Speed-Work load graph>
(LEFS25GA/Battery-less absolute)

Step 1 Check the work load-speed. <Speed-Work load graph> (pages 10 to 13)
Select a model based on the workpiece mass and speed while referencing the speed-work load graph.

Selection example) The **LEFS25GA-200** can be temporarily selected as a possible candidate based on the graph shown on the right side.

Step 2 Check the cycle time.

Calculate the **cycle time** using the following calculation method.

Cycle time:

T can be found from the following equation.

$$T = T1 + T2 + T3 + T4 \text{ [s]}$$

- T1: Acceleration time and T3: Deceleration time can be found by the following equation.

$$T1 = V/a1 \text{ [s]} \quad T3 = V/a2 \text{ [s]}$$

- T2: Constant speed time can be found from the following equation.

$$T2 = \frac{L - 0.5 \cdot V \cdot (T1 + T3)}{V} \text{ [s]}$$

- T4: Settling time varies depending on the conditions such as actuator types, load, and in position of the step data. Reference value for settling time: 0.15 s or less. The following value is used for this calculation.

$$T4 = 0.15 \text{ [s]}$$

Calculation example)

T1 to T4 can be calculated as follows.

$$T1 = V/a1 = 300/10000 = 0.03 \text{ [s]}$$

$$T3 = V/a2 = 300/10000 = 0.03 \text{ [s]}$$

$$T2 = \frac{L - 0.5 \cdot V \cdot (T1 + T3)}{V} = \frac{200 - 0.5 \cdot 300 \cdot (0.03 + 0.03)}{300} = 0.64 \text{ [s]}$$

$$T4 = 0.15 \text{ [s]}$$

The **cycle time** can be found as follows.

$$T = T1 + T2 + T3 + T4 = 0.03 + 0.64 + 0.03 + 0.15 = 0.85 \text{ [s]}$$

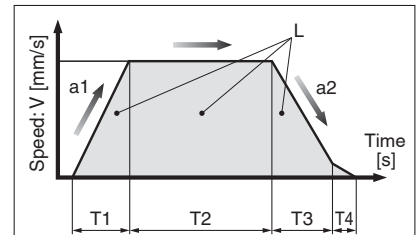

- L : Stroke [mm] ... (Operating condition)
- V : Speed [mm/s] ... (Operating condition)
- a1 : Acceleration [mm/s²] ... (Operating condition)
- a2 : Deceleration [mm/s²] ... (Operating condition)

- T1: Acceleration time [s]
Time until reaching the set speed
- T2: Constant speed time [s]
Time while the actuator is operating at a constant speed
- T3: Deceleration time [s]
Time from the beginning of the constant speed operation to stop
- T4: Settling time [s]
Time until positioning is completed

Step 3 Check the allowable moment.

<Static allowable moment> (page 13)
<Dynamic allowable moment> (pages 14, 15)

Confirm the moment that applies to the actuator is within the allowable range for both static and dynamic conditions.

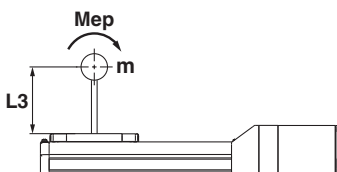

Based on the above calculation result, the **LEFS25GA-200** should be selected.

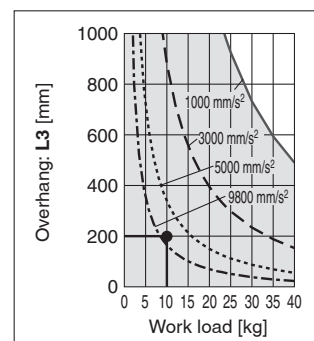

Speed-Work Load Graph (Guide)

* The following graphs show the values when the moving force is 100 %.

LEFS16GA/Ball Screw Drive

Horizontal/Lead 10

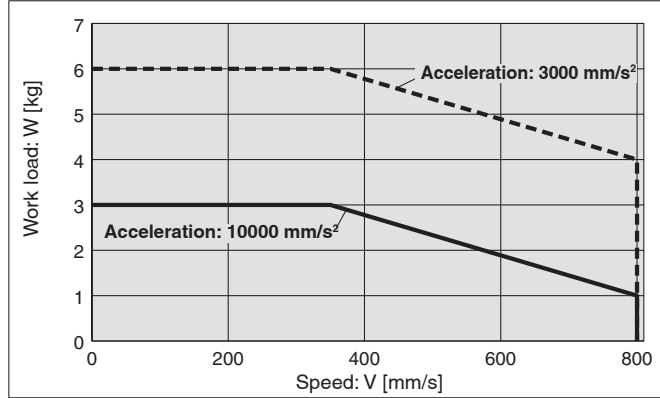

Vertical/Lead 10

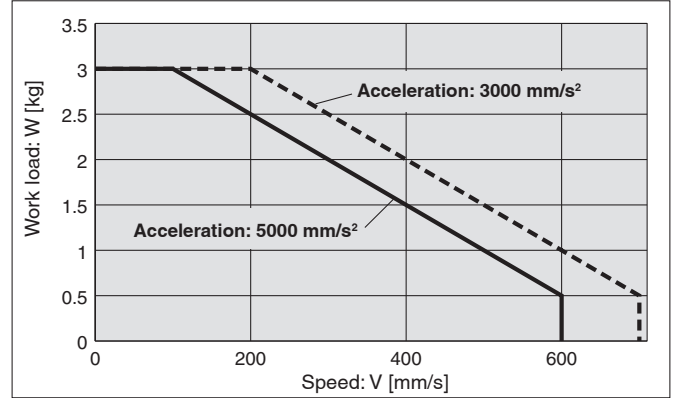

LEFS16GB/Ball Screw Drive

Horizontal/Lead 5

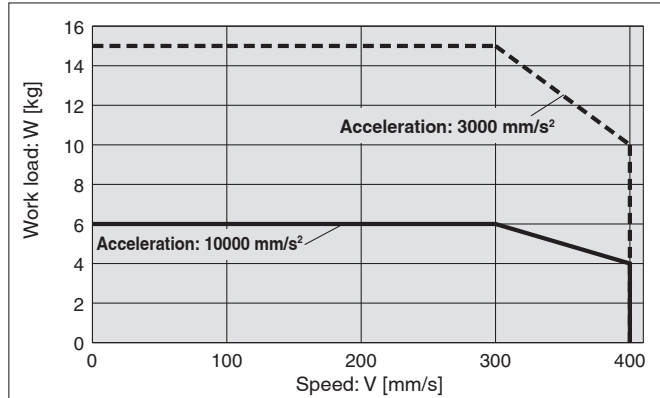

Vertical/Lead 5

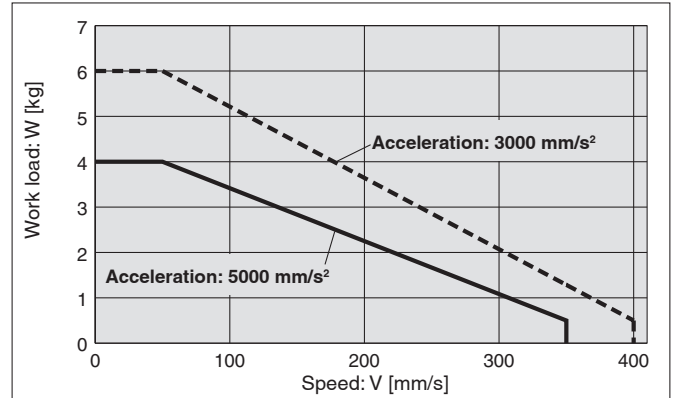

Operating temperature: Use products with a duty ratio of 100 % or less when the temperature is below 30 °C and with a duty ratio of 35 % or less when the temperature exceeds 30 °C.

Speed-Work Load Graph (Guide)

* The following graphs show the values when the moving force is 100 %.

LEFS25GH/Ball Screw Drive

Horizontal/Lead 20

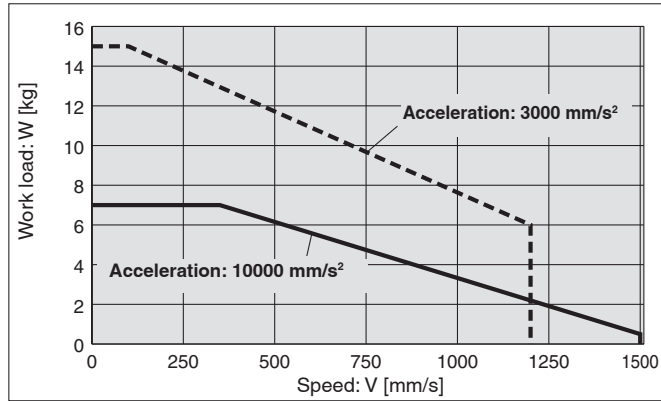

Vertical/Lead 20

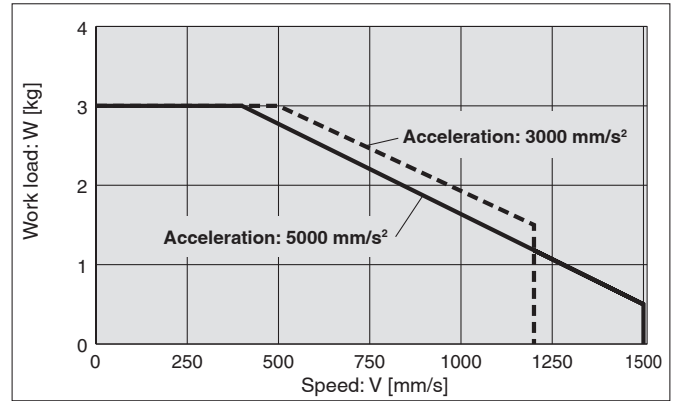

LEFS25GA/Ball Screw Drive

Horizontal/Lead 12

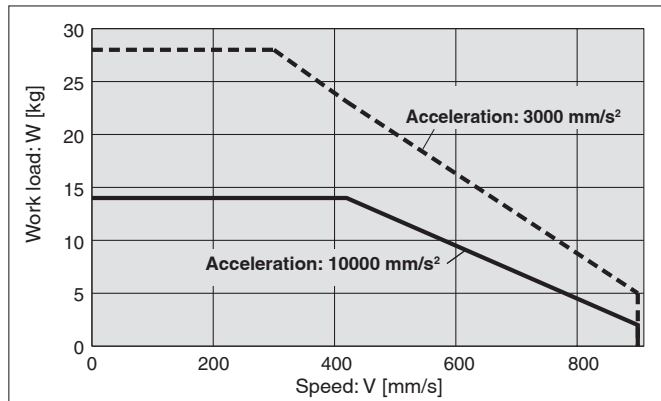

Vertical/Lead 12

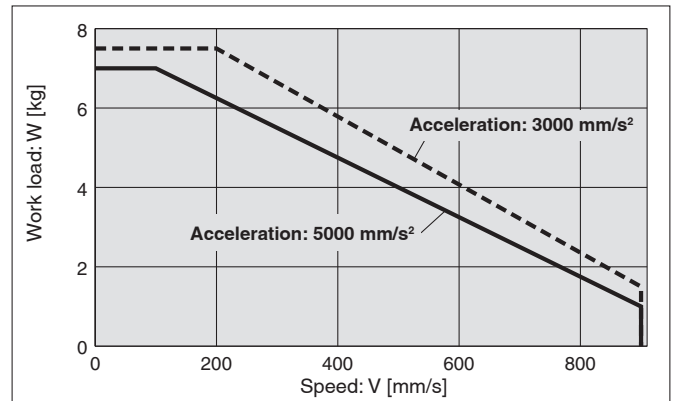

LEFS25GB/Ball Screw Drive

Horizontal/Lead 6

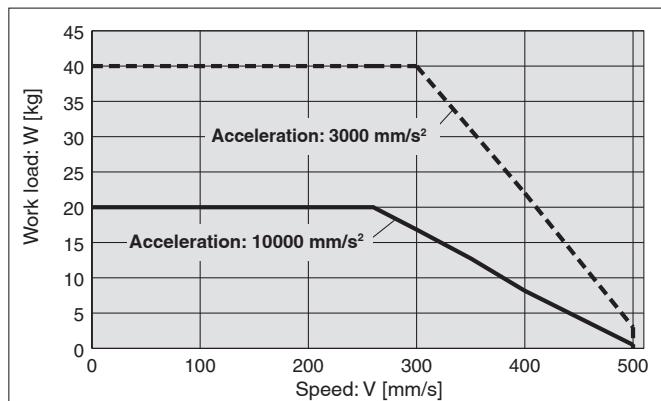

Vertical/Lead 6

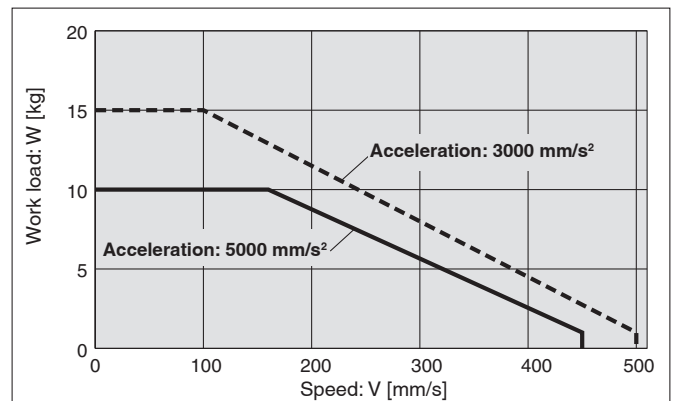

Operating temperature: Use products with a duty ratio of 100 % or less when the temperature is below 30 °C and with a duty ratio of 35 % or less when the temperature exceeds 30 °C.

Speed-Work Load Graph (Guide)

* The following graphs show the values when the moving force is 100 %.

LEFS32GH/Ball Screw Drive

Horizontal/Lead 24

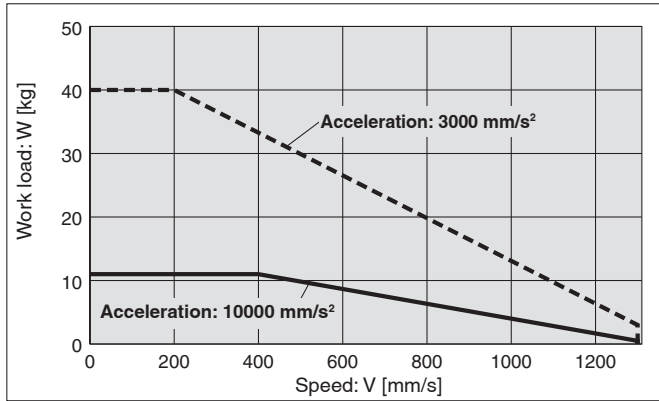

Vertical/Lead 24

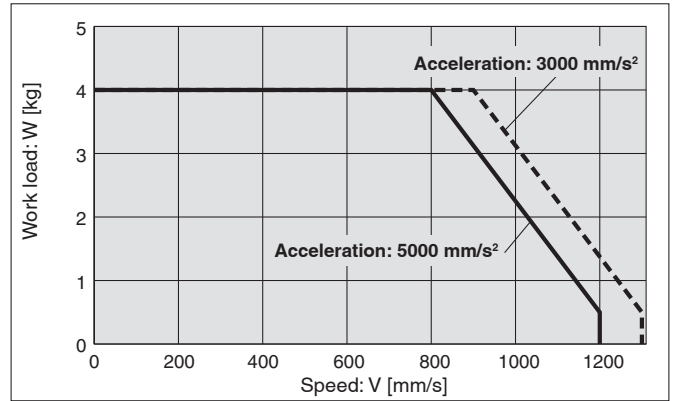

LEFS32GA/Ball Screw Drive

Horizontal/Lead 16

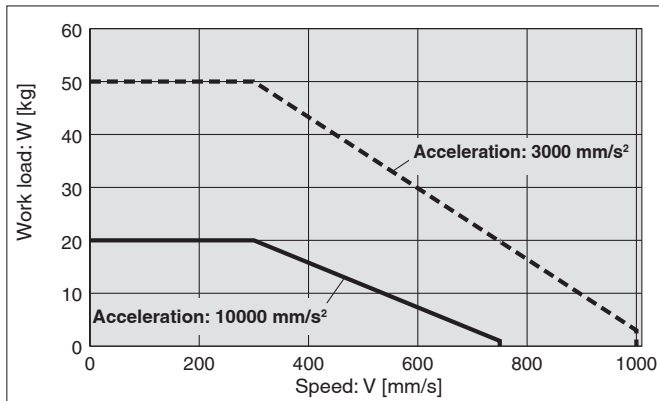

Vertical/Lead 16

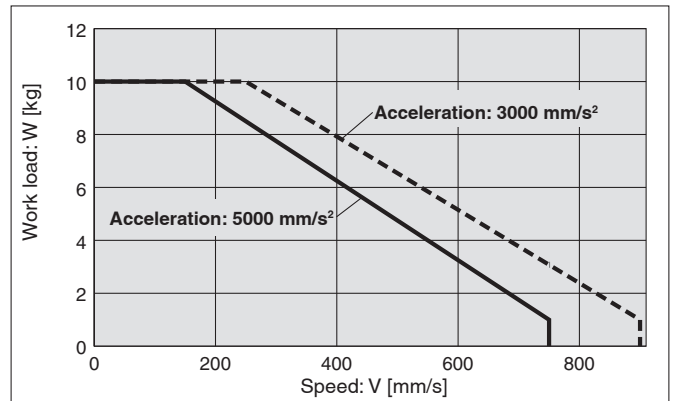

LEFS32GB/Ball Screw Drive

Horizontal/Lead 8

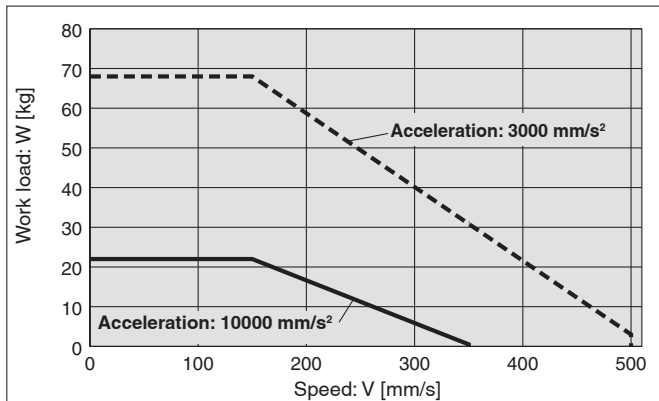

Vertical/Lead 8

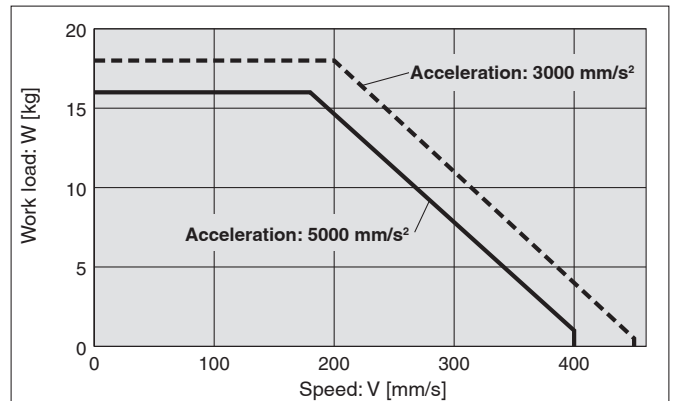

Operating temperature: Use products with a duty ratio of 100 % or less when the temperature is below 30 °C and with a duty ratio of 35 % or less when the temperature exceeds 30 °C.

Speed-Work Load Graph (Guide)

* The following graphs show the values when the moving force is 100 %.

LEFS40GH/Ball Screw Drive

Horizontal/Lead 30

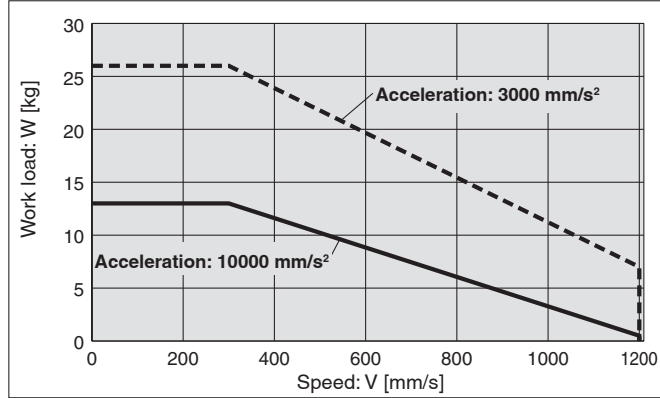

Vertical/Lead 30

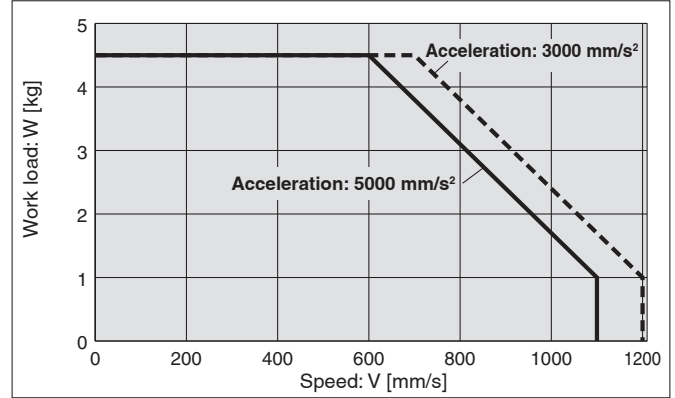

LEFS40GA/Ball Screw Drive

Horizontal/Lead 20

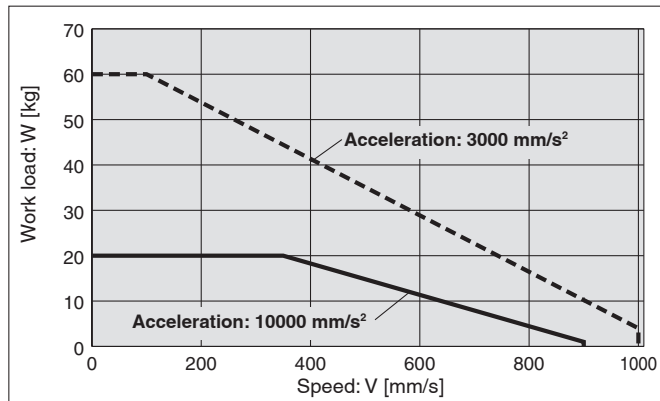

Vertical/Lead 20

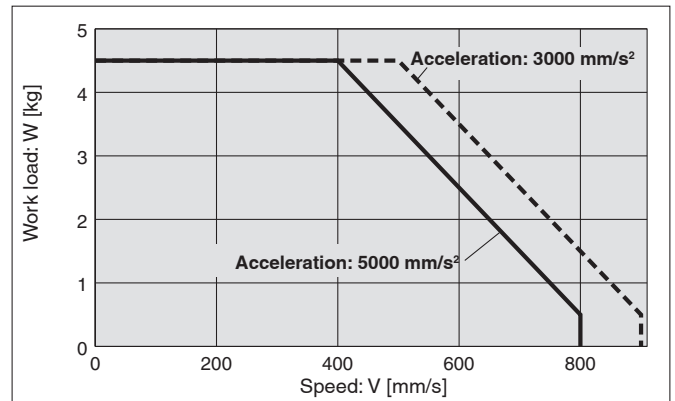

LEFS40GB/Ball Screw Drive

Horizontal/Lead 10

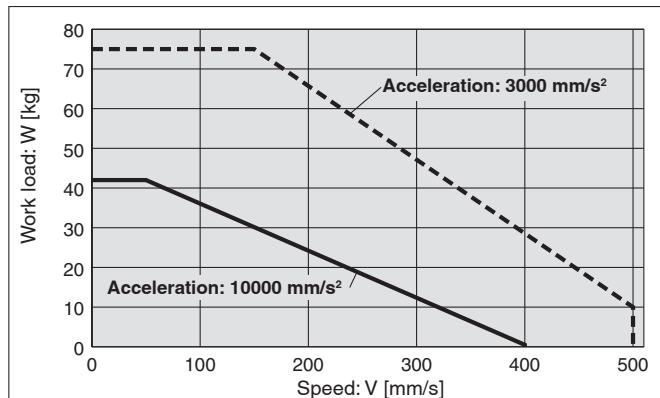

Vertical/Lead 10

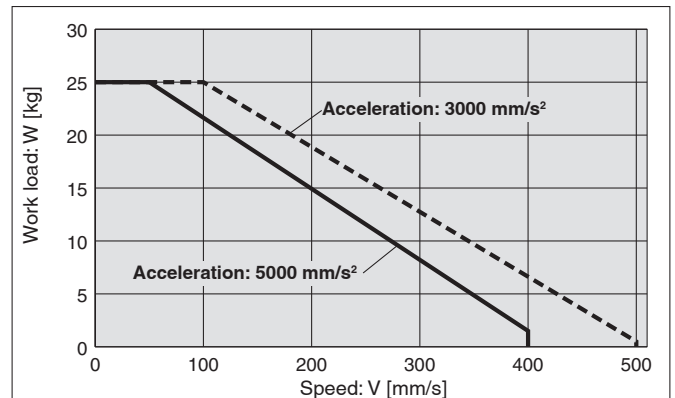

Operating temperature: Use products with a duty ratio of 100 % or less when the temperature is below 30 °C and with a duty ratio of 35 % or less when the temperature exceeds 30 °C.

Static Allowable Moment^{*1}

| Model | Size | Pitching | Yawing | Rolling |
|--------|------|----------|--------|---------|
| LEFS□G | 16 | 10.0 | 10.0 | 20.0 |
| | 25 | 27.0 | 27.0 | 52.0 |
| | 32 | 46.0 | 46.0 | 101.0 |
| | 40 | 110.0 | 110.0 | 207.0 |

*1 The static allowable moment is the amount of static moment which can be applied to the actuator when it is stopped. If the product is exposed to impact or repeated load, be sure to take adequate safety measures when using the product.

Dynamic Allowable Moment

* These graphs show the amount of allowable overhang (guide unit) when the centre of gravity of the workpiece overhangs in one direction.

Acceleration ——— 1000 mm/s² - - - 3000 mm/s² 5000 mm/s² - - - - 10000 mm/s²

| Orientation | Load overhanging direction m : Work load [kg] Me: Allowable moment [N·m] L : Overhang to the work load centre of gravity [mm] | Model | | | |
|-------------------|--|---------|---------|---------|---------|
| | | LEFS16G | LEFS25G | LEFS32G | LEFS40G |
| Horizontal/Bottom | X L1 [mm] | | | | |
| | Y L2 [mm] | | | | |
| | Z L3 [mm] | | | | |
| Wall | X L4 [mm] | | | | |
| | Y L5 [mm] | | | | |
| | Z L6 [mm] | | | | |

Dynamic Allowable Moment

* These graphs show the amount of allowable overhang (guide unit) when the centre of gravity of the workpiece overhangs in one direction.

Acceleration ——— 1000 mm/s² - - - 3000 mm/s² 5000 mm/s²

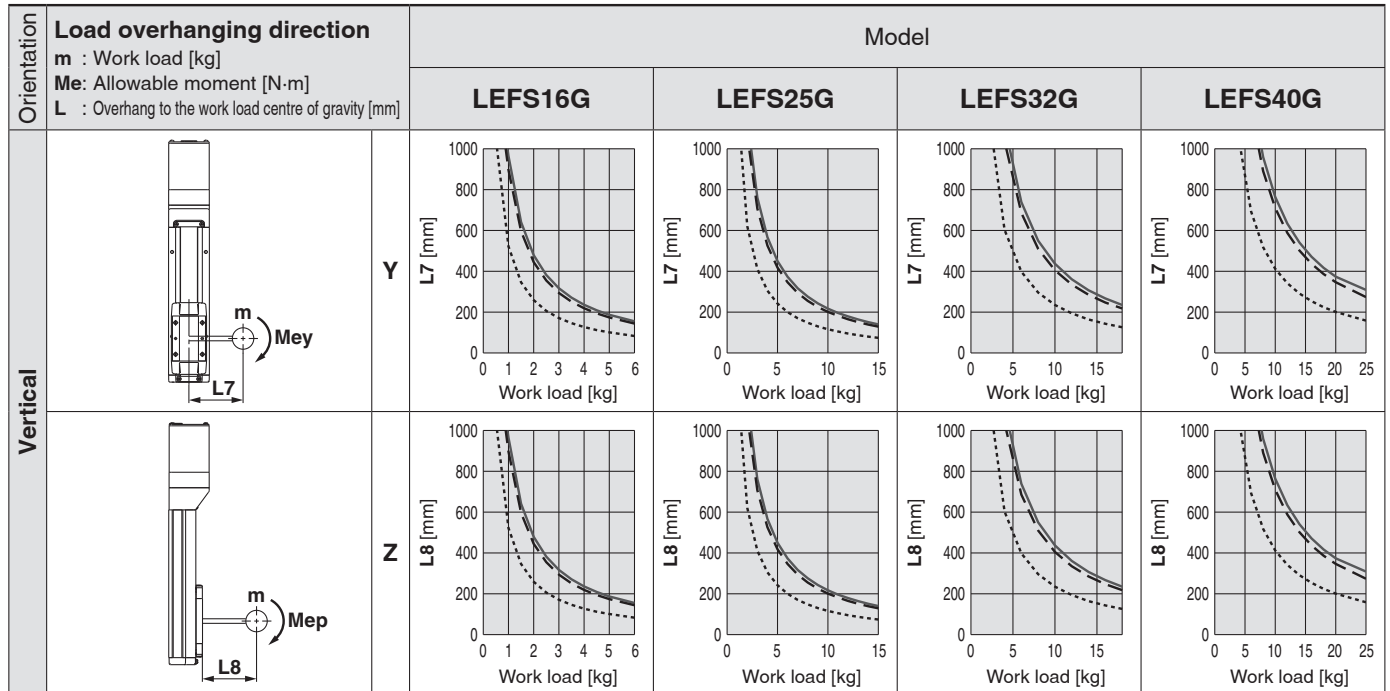

Calculation of Guide Load Factor

- Decide operating conditions.

Model: LEFS□G

Size: 25/32/40

Mounting orientation: Horizontal/Bottom/Wall/Vertical

Acceleration [mm/s²]: a

Work load [kg]: m

Work load centre position [mm]: Xc/Yc/Zc

- Select the target graph while referencing the model, size, and mounting orientation.

- Based on the acceleration and work load, find the overhang [mm]: Lx/Ly/Lz from the graph.

- Calculate the load factor for each direction.

$$\alpha_x = X_c/L_x, \alpha_y = Y_c/L_y, \alpha_z = Z_c/L_z$$

- Confirm the total of α_x , α_y , and α_z is 1 or less.

$$\alpha_x + \alpha_y + \alpha_z \leq 1$$

When 1 is exceeded, please consider a reduction of acceleration and work load, or a change of the work load centre position and series.

Example

- Operating conditions

Model: LEFS40G

Size: 40

Mounting orientation: Horizontal

Acceleration [mm/s²]: 3000

Work load [kg]: 20

Work load centre position [mm]: Xc = 0, Yc = 50, Zc = 200

- Select the graphs for horizontal of the LEFS40G on page 14.

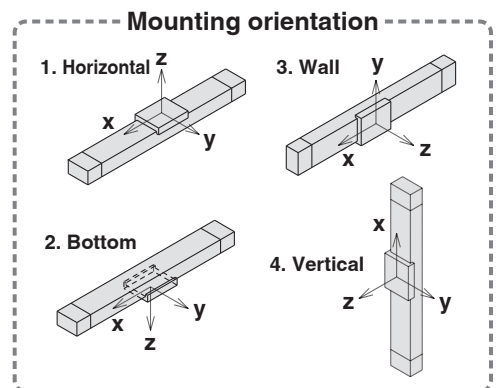

- Lx = 350 mm, Ly = 250 mm, Lz = 1000 mm

- The load factor for each direction can be found as follows.

$$\alpha_x = 0/350 = 0$$

$$\alpha_y = 50/250 = 0.2$$

$$\alpha_z = 200/1000 = 0.2$$

- $\alpha_x + \alpha_y + \alpha_z = 0.4 \leq 1$

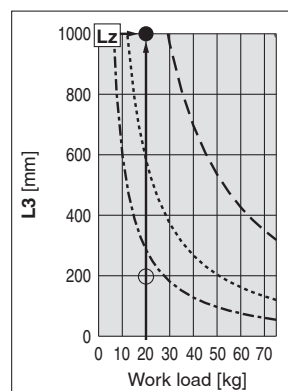
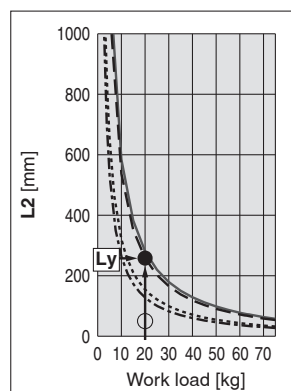
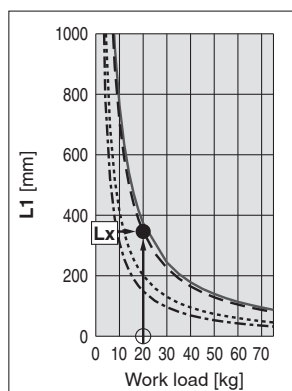
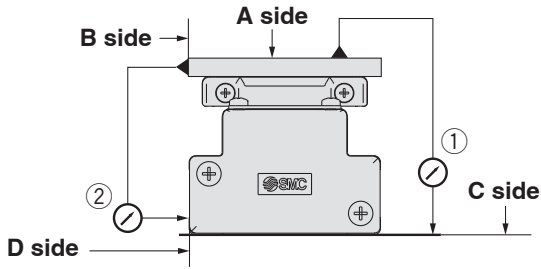

Table Accuracy (Reference Value)



| Model | Travelling parallelism [mm] (Every 300 mm) | |
|----------------|--|---|
| | ① C side travelling parallelism to A side | ② D side travelling parallelism to B side |
| LEFS16G | 0.05 | 0.03 |
| LEFS25G | 0.05 | 0.03 |
| LEFS32G | 0.05 | 0.03 |
| LEFS40G | 0.05 | 0.03 |

* Travelling parallelism does not include the mounting surface accuracy. (Excludes when the stroke exceeds 2000 mm)

Table Displacement (Reference Value)

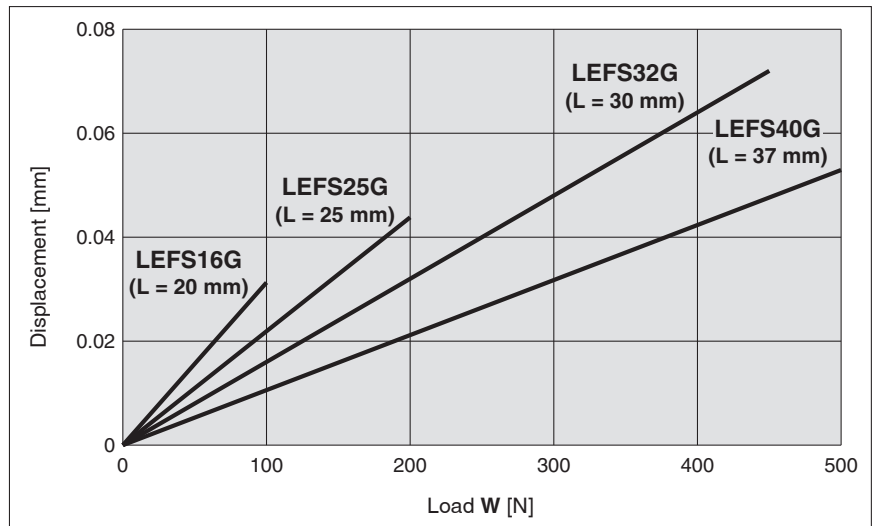
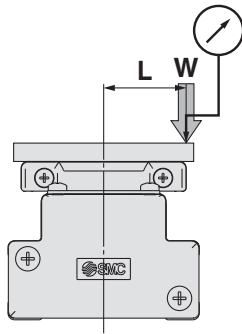

* This displacement is measured when a 15 mm aluminium plate is mounted and fixed on the table.
 * Check the clearance and play of the guide separately.

Overhang Displacement Due to Table Clearance (Initial Reference Value)

Basic type

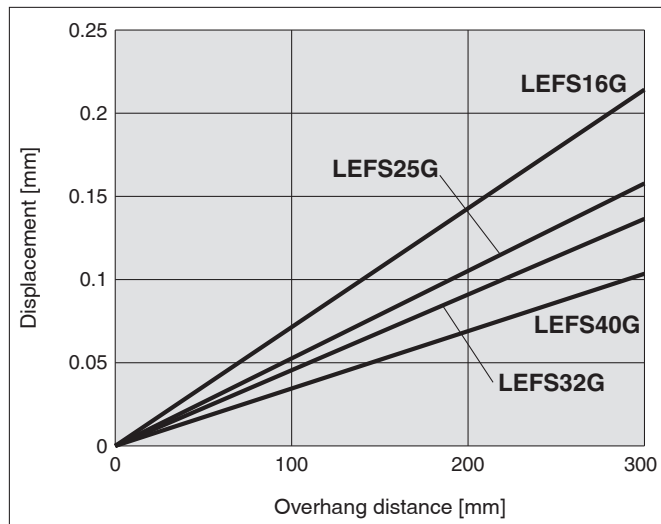

High-precision type

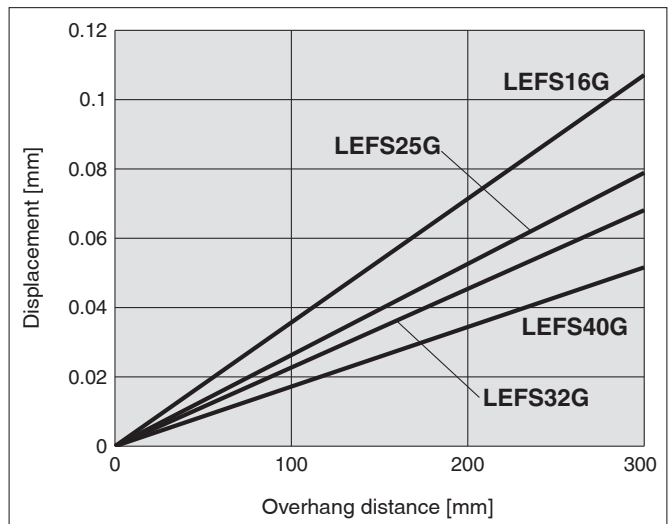

Battery-less Absolute (Step Motor 24 VDC)

High Performance Slider Type Ball Screw Drive LEFS□G Series LEFS16, 25, 32, 40



RoHS

How to Order



LEFS **H** **25** **G** **B** - **200** **C** **N** **K** - **R1** **C5H73**

1 2 3 4 5 6 7 8 9 10 11 12

For details on controllers, refer to the next page.

1 Accuracy

| | |
|---|---------------------|
| — | Basic type |
| H | High-precision type |

2 Size

| |
|----|
| 16 |
| 25 |
| 32 |
| 40 |

3 Motor mounting position

| | |
|---|---------------------|
| — | In-line |
| R | Right side parallel |
| L | Left side parallel |

5 Lead [mm]

| Symbol | LEFS16 | LEFS25 | LEFS32 | LEFS40 |
|--------|--------|--------|--------|--------|
| H | — | 20 | 24 | 30 |
| A | 10 | 12 | 16 | 20 |
| B | 5 | 6 | 8 | 10 |

8 Auto switch compatibility (In-line only)*2 *3 *4 *5 *6

| | |
|---|------------------------------------|
| — | None |
| C | With (Includes 1 mounting bracket) |

9 Grease application (Seal band part)

| | |
|---|--------------------------------|
| — | With |
| N | Without (Roller specification) |

10 Positioning pin hole

| | | |
|---|-------------------------|--|
| — | Housing B bottom*6 | |
| K | Body bottom 2 locations | |

4 Motor type

| Symbol | Type | Applicable size | | | | Compatible controllers |
|--------|--|-----------------|--------|--------|--------|---|
| | | LEFS16 | LEFS25 | LEFS32 | LEFS40 | |
| G | High performance (Battery-less absolute) | ● | ● | ● | ● | JXC5H JXC6H JXCEH JXC9H JXCPH |

6 Stroke*1 [mm]

| Stroke | Note | |
|-------------|------|---|
| | Size | Applicable stroke |
| 50 to 500 | 16 | 50, 100, 150, 200, 250, 300, 350, 400, 450, 500 |
| 50 to 800 | 25 | 50, 100, 150, 200, 250, 300, 350, 400, 450, 500, 550, 600, 650, 700, 750, 800 |
| 50 to 1000 | 32 | 50, 100, 150, 200, 250, 300, 350, 400, 450, 500, 550, 600, 650, 700, 750, 800, 850, 900, 950, 1000 |
| 150 to 1200 | 40 | 150, 200, 250, 300, 350, 400, 450, 500, 550, 600, 650, 700, 750, 800, 850, 900, 950, 1000, 1100, 1200 |

7 Motor option

| | |
|---|----------------|
| — | Without option |
| B | With lock |

11 Actuator cable type/length

| Robotic cable [m] | | | |
|-------------------|-----|----|------|
| R1 | 1.5 | RA | 10*7 |
| R3 | 3 | RB | 15*7 |
| R5 | 5 | RC | 20*7 |
| R8 | 8*7 | | |

For auto switches, refer to pages 37 to 40.

12 Controller

| | |
|-------|--------------------|
| — | Without controller |
| C□H□□ | With controller |

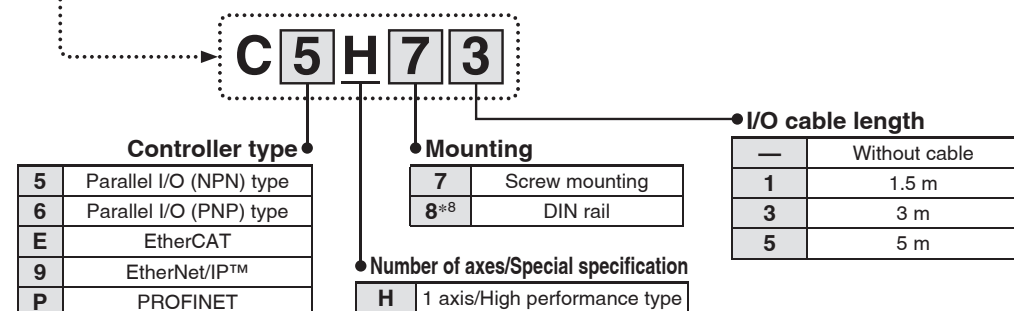

- *1 Please contact SMC for non-standard strokes as they are produced as special orders.
- *2 Excluding the LEFS16
- *3 If 2 or more are required, please order them separately. (Part no.: LEF-D-2-1 For details, refer to the **Web Catalogue**.)
- *4 The auto switches must be ordered separately. (For details, refer to the **Web Catalogue**.)

- *5 When “—” is selected, the product will not come with a built-in magnet for an auto switch, and so a mounting bracket cannot be secured. Be sure to select an appropriate model initially as the product cannot be changed to have auto switch compatibility after purchase.
- *6 For details on the mounting method, refer to the **Web Catalogue**.
- *7 Produced upon receipt of order
- *8 The DIN rail is not included. It must be ordered separately.

⚠ Caution

[CE/UKCA-compliant products]

EMC compliance was tested by combining the electric actuator LEF series and the controller JXC series.

The EMC depends on the configuration of the customer's control panel and the relationship with other electrical equipment and wiring. Therefore, compliance with the EMC directive cannot be certified for SMC components incorporated into the customer's equipment under actual operating conditions. As a result, it is necessary for the customer to verify compliance with the EMC directive for the machinery and equipment as a whole.

■ Trademark

EtherNet/IP® is a registered trademark of ODVA, Inc.
 EtherCAT® is registered trademark and patented technology, licensed by Beckhoff Automation GmbH, Germany.

The actuator and controller are sold as a package.

Confirm that the combination of the controller and actuator is correct.

<Check the following before use.>

- *1 Check the actuator label for the model number. This number should match that of the controller.

LEFS25GA-400

*1



- * Refer to the Operation Manual for using the products. Please download it via our website: <https://www.smc.eu>

| Type | Step data input type | EtherCAT direct input type | EtherNet/IP™ direct input type | PROFINET direct input type |
|---------------------------------|------------------------|----------------------------|--------------------------------|----------------------------|
| | | | | |
| Series | JXC5H JXC6H | JXCEH | JXC9H | JXC9H |
| Features | Parallel I/O | EtherCAT direct input | EtherNet/IP™ direct input | PROFINET direct input |
| Compatible motor | Step motor 24 VDC | | | |
| Max. number of step data | 64 points | | | |
| Power supply voltage | 24 VDC | | | |
| Reference page | 43 | 50 | | |

Specifications

| Model | | LEFS16G | | LEFS25G | | | LEFS32G | | | LEFS40G | | | | |
|---|---|---|------------------------|----------------|----------|------------|----------------|----------|------------|----------------|-----------|------------|------------|-----------|
| Actuator specifications | Stroke [mm]*1 | 50 to 500 | | 50 to 800 | | | 50 to 1000 | | | 150 to 1200 | | | | |
| | Work load [kg]*2 | Horizontal | | 6 | 15 | 15 | 28 | 40 | 40 | 50 | 68 | 26 | 60 | 75 |
| | | Vertical | | 3 | 6 | 3 | 7.5 | 15 | 4 | 10 | 18 | 4.5 | 4.5 | 25 |
| | Speed [mm/s] | Stroke range | Up to 400 | 10 to 800 | 5 to 400 | 20 to 1500 | 12 to 900 | 6 to 500 | 24 to 1300 | 16 to 1000 | 8 to 500 | 30 to 1200 | 20 to 1000 | 10 to 500 |
| | | | 401 to 450 | 10 to 700 | 5 to 360 | 20 to 1100 | 12 to 750 | 6 to 400 | 24 to 1300 | 16 to 950 | 8 to 500 | 30 to 1200 | 20 to 1000 | 10 to 500 |
| | | | 451 to 500 | 10 to 600 | 5 to 300 | 20 to 1100 | 12 to 750 | 6 to 400 | 24 to 1300 | 16 to 950 | 8 to 500 | 30 to 1200 | 20 to 1000 | 10 to 500 |
| | | | 501 to 600 | — | — | 20 to 900 | 12 to 540 | 6 to 270 | 24 to 1200 | 16 to 800 | 8 to 400 | 30 to 1200 | 20 to 1000 | 10 to 500 |
| | | | 601 to 700 | — | — | 20 to 630 | 12 to 420 | 6 to 230 | 24 to 930 | 16 to 620 | 8 to 310 | 30 to 1200 | 20 to 900 | 10 to 440 |
| | | | 701 to 800 | — | — | 20 to 550 | 12 to 330 | 6 to 180 | 24 to 750 | 16 to 500 | 8 to 250 | 30 to 1140 | 20 to 760 | 10 to 350 |
| | | | 801 to 900 | — | — | — | — | — | 24 to 610 | 16 to 410 | 8 to 200 | 30 to 930 | 20 to 620 | 10 to 280 |
| | | | 901 to 1000 | — | — | — | — | — | 24 to 500 | 16 to 340 | 8 to 170 | 30 to 780 | 20 to 520 | 10 to 250 |
| | | | 1001 to 1100 | — | — | — | — | — | — | — | — | 30 to 660 | 20 to 440 | 10 to 220 |
| | 1101 to 1200 | — | — | — | — | — | — | — | — | 30 to 570 | 20 to 380 | 10 to 190 | | |
| | Max. acceleration/deceleration [mm/s ²] | Horizontal | 10000 | | | | | | | | | | | |
| | | Vertical | 5000 | | | | | | | | | | | |
| | Positioning repeatability [mm] | Basic type | ±0.02 | | | | | | | | | | | |
| | | High-precision type | ±0.015 (Lead H: ±0.02) | | | | | | | | | | | |
| | Lost motion [mm]*3 | Basic type | 0.1 or less | | | | | | | | | | | |
| | | High-precision type | 0.05 or less | | | | | | | | | | | |
| Lead [mm] | | 10 | 5 | 20 | 12 | 6 | 24 | 16 | 8 | 30 | 20 | 10 | | |
| Impact/Vibration resistance [m/s ²]*4 | | 50/20 | | | | | | | | | | | | |
| Actuation type | | Ball screw (LEFS□), Ball screw + Belt (LEFS□ ^R) | | | | | | | | | | | | |
| Guide type | | Linear guide | | | | | | | | | | | | |
| Static allowable moment*5 [N·m] | Mep (Pitching) | 10 | | 27 | | | 46 | | | 110 | | | | |
| | Mey (Yawing) | 10 | | 27 | | | 46 | | | 110 | | | | |
| | Mer (Rolling) | 20 | | 52 | | | 101 | | | 207 | | | | |
| Operating temperature range [°C] | | 5 to 40 | | | | | | | | | | | | |
| Operating humidity range [%RH] | | 90 or less (No condensation) | | | | | | | | | | | | |
| Electric specifications | Motor size | □28 | | □42 | | | □56.4 | | | □56.4 | | | | |
| | Motor type | Battery-less absolute (Step motor 24 VDC) | | | | | | | | | | | | |
| | Encoder | Battery-less absolute encoder | | | | | | | | | | | | |
| | Power supply voltage [V] | 24 VDC ±10 % | | | | | | | | | | | | |
| | Power [W]*6 *8 | Max. power 116 | | Max. power 126 | | | Max. power 222 | | | Max. power 222 | | | | |
| Lock unit specifications | Type*7 | Non-magnetising lock | | | | | | | | | | | | |
| | Holding force [N] | 29 | 59 | 47 | 78 | 157 | 72 | 108 | 216 | 75 | 113 | 245 | | |
| | Power [W]*8 | 2.9 | | 5 | | | 5 | | | 5 | | | | |
| | Rated voltage [V] | 24 VDC ±10 % | | | | | | | | | | | | |

*1 Please contact SMC for non-standard strokes as they are produced as special orders.

*2 The max. work load at 3000 mm/s² acceleration and deceleration speed. For the speed, acceleration, and duty ratio according to the work load, check the "Speed-Work Load Graph" on pages 10 to 13.

Furthermore, if the cable length exceeds 5 m, the speed and work load specified in the "Speed-Work Load Graph" may decrease by up to 10 % for each 5 m increase.

*3 A reference value for correcting errors in reciprocal operation

*4 Impact resistance: No malfunction occurred when the actuator was tested with a drop tester in both an axial direction and a perpendicular direction to the lead screw. (The test was performed with the actuator in the initial state.)

Vibration resistance: No malfunction occurred in a test ranging between 45 to 2000 Hz. The test was performed in both an axial direction and a perpendicular direction to the lead screw. (The test was performed with the actuator in the initial state.)

*5 The static allowable moment is the amount of static moment which can be applied to the actuator when it is stopped.

If the product is exposed to impact or repeated load, be sure to take adequate safety measures when using the product.

*6 Indicates the max. power during operation (including the controller)

This value can be used for the selection of the power supply.

*7 With lock only

*8 For an actuator with lock, add the power for the lock.

Weight

| Series | LEFS16G | | | | | | | | | |
|----------------------------------|---------|------|------|------|------|------|------|------|------|------|
| Stroke [mm] | 50 | 100 | 150 | 200 | 250 | 300 | 350 | 400 | 450 | 500 |
| Product weight [kg] | 0.85 | 0.92 | 1.00 | 1.07 | 1.15 | 1.22 | 1.30 | 1.37 | 1.45 | 1.52 |
| Additional weight with lock [kg] | 0.12 | | | | | | | | | |

| Series | LEFS25G | | | | | | | | | | | | | | | |
|----------------------------------|---------|------|------|------|------|------|------|------|------|------|------|------|------|------|------|------|
| Stroke [mm] | 50 | 100 | 150 | 200 | 250 | 300 | 350 | 400 | 450 | 500 | 550 | 600 | 650 | 700 | 750 | 800 |
| Product weight [kg] | 1.70 | 1.84 | 1.98 | 2.12 | 2.26 | 2.40 | 2.54 | 2.68 | 2.82 | 2.96 | 3.10 | 3.24 | 3.38 | 3.52 | 3.66 | 3.80 |
| Additional weight with lock [kg] | 0.26 | | | | | | | | | | | | | | | |

| Series | LEFS32G | | | | | | | | | | | | | | | | | | | |
|----------------------------------|---------|------|------|------|------|------|------|------|------|------|------|------|------|------|------|------|------|------|------|------|
| Stroke [mm] | 50 | 100 | 150 | 200 | 250 | 300 | 350 | 400 | 450 | 500 | 550 | 600 | 650 | 700 | 750 | 800 | 850 | 900 | 950 | 1000 |
| Product weight [kg] | 3.55 | 3.75 | 3.95 | 4.15 | 4.35 | 4.55 | 4.75 | 4.95 | 5.15 | 5.35 | 5.55 | 5.75 | 5.95 | 6.15 | 6.35 | 6.55 | 6.75 | 6.95 | 7.15 | 7.35 |
| Additional weight with lock [kg] | 0.53 | | | | | | | | | | | | | | | | | | | |

| Series | LEFS40G | | | | | | | | | | | | | | | | | | | |
|----------------------------------|---------|------|------|------|------|------|------|------|------|------|------|------|------|------|------|------|------|-------|-------|-------|
| Stroke [mm] | 150 | 200 | 250 | 300 | 350 | 400 | 450 | 500 | 550 | 600 | 650 | 700 | 750 | 800 | 850 | 900 | 950 | 1000 | 1100 | 1200 |
| Product weight [kg] | 5.37 | 5.65 | 5.93 | 6.21 | 6.49 | 6.77 | 7.15 | 7.33 | 7.61 | 7.89 | 8.17 | 8.45 | 8.73 | 9.01 | 9.29 | 9.57 | 9.85 | 10.13 | 10.69 | 11.25 |
| Additional weight with lock [kg] | 0.53 | | | | | | | | | | | | | | | | | | | |

Dimensions: In-line Motor

LEFS16G

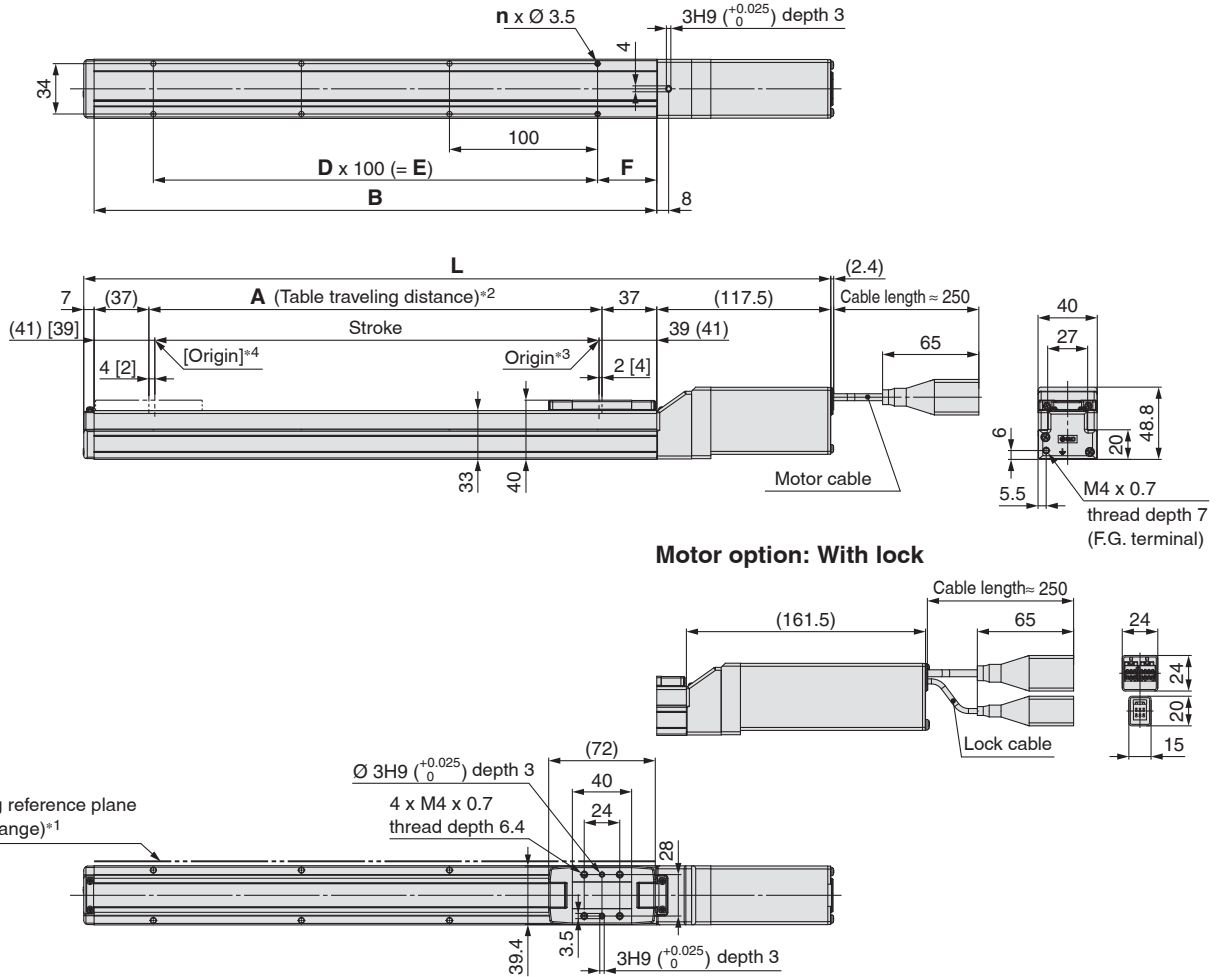

- *1 When mounting the actuator using the body mounting reference plane, set the height of the opposite surface or pin to be 2 mm or more because of round chamfering. (Recommended height: 5 mm)
In addition, be aware that surfaces other than the body mounting reference plane (B dimension range) may slightly protrude from the body mounting reference plane. Be sure to provide a clearance of 1 mm or more to avoid interference with workpieces, facilities, etc.
- *2 This is the distance within which the table can move when it returns to origin.
Make sure that workpieces mounted on the table do not interfere with other workpieces or the facilities around the table.
- *3 Position after returning to origin
- *4 [] for when the direction of return to origin has changed

Dimensions

[mm]

| Model | L | | A | B | n | D | E | F |
|--|--------------|-----------|-----|-----|----|---|-----|----|
| | Without lock | With lock | | | | | | |
| LEFS16G -50 | 254.5 | 298.5 | 56 | 130 | 4 | — | — | 15 |
| LEFS16G -100 | 304.5 | 348.5 | 106 | 180 | | | | |
| LEFS16G -150 | 354.5 | 398.5 | 156 | 230 | | | | |
| LEFS16G -200 | 404.5 | 448.5 | 206 | 280 | 6 | 2 | 200 | 40 |
| LEFS16G -250 | 454.5 | 498.5 | 256 | 330 | | | | |
| LEFS16G -300 | 504.5 | 548.5 | 306 | 380 | 8 | 3 | 300 | |
| LEFS16G -350 | 554.5 | 598.5 | 356 | 430 | | | | |
| LEFS16G -400 | 604.5 | 648.5 | 406 | 480 | 10 | 4 | 400 | |
| LEFS16G -450 | 654.5 | 698.5 | 456 | 530 | | | | |
| LEFS16G -500 | 704.5 | 748.5 | 506 | 580 | 12 | 5 | 500 | |

Dimensions: In-line Motor

LEFS16G

Positioning pin hole*1 (Option): Body bottom

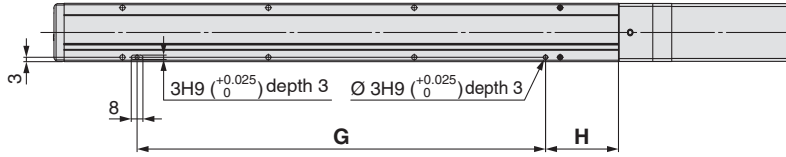

*1 When using the body bottom positioning pin holes, do not simultaneously use the housing B bottom pin hole.

Dimensions [mm]

| Model | Positioning pin hole: K | |
|---------------|-------------------------|----|
| | G | H |
| LEFS16G□-50□ | 80 | 25 |
| LEFS16G□-100□ | | 50 |
| LEFS16G□-150□ | | |
| LEFS16G□-200□ | | |
| LEFS16G□-250□ | | |
| LEFS16G□-300□ | | |
| LEFS16G□-350□ | 280 | |
| LEFS16G□-400□ | 380 | |
| LEFS16G□-450□ | 480 | |
| LEFS16G□-500□ | | |

Dimensions: In-line Motor

LEFS25G

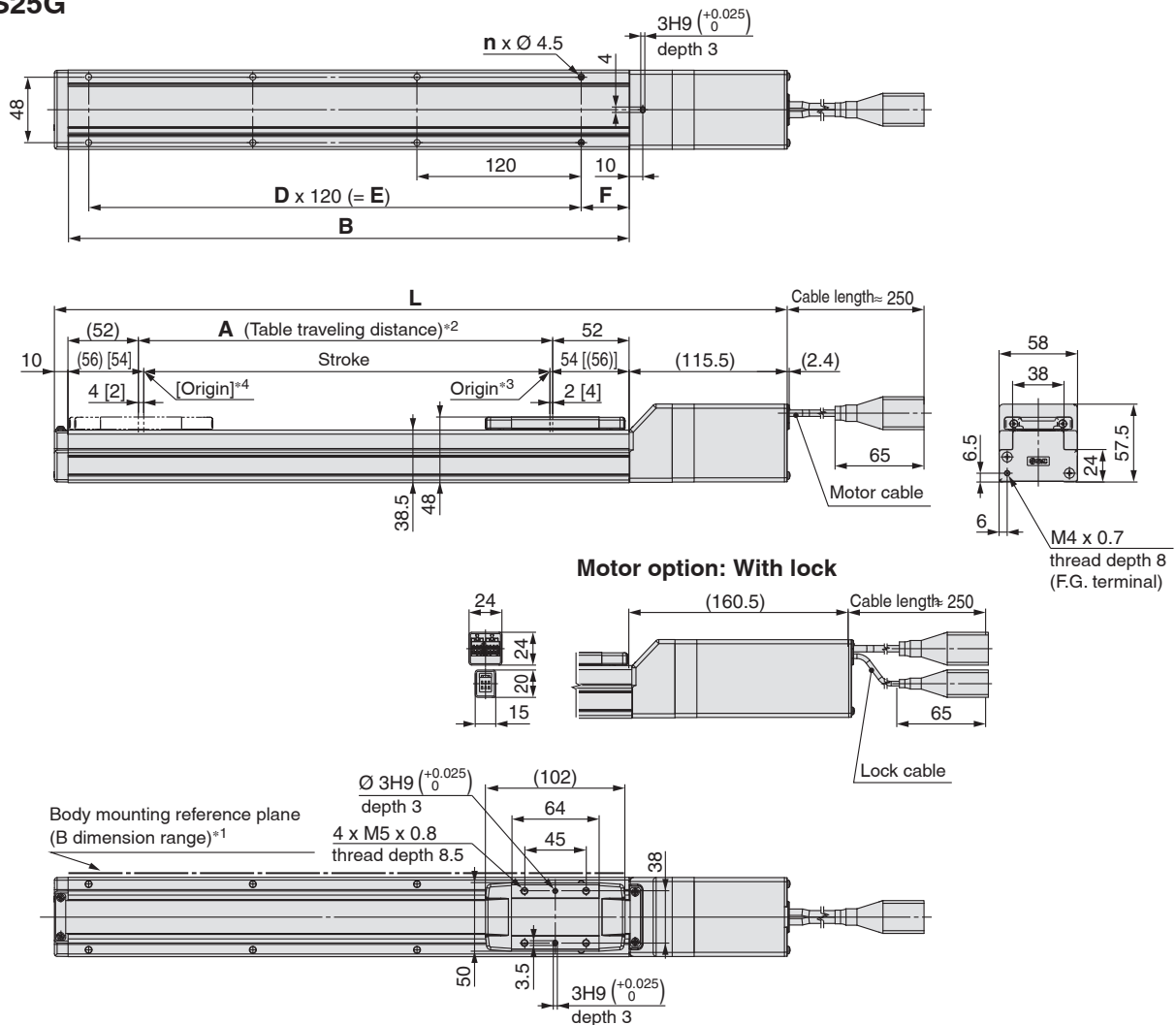

- *1 When mounting the actuator using the body mounting reference plane, set the height of the opposite surface or pin to be 3 mm or more because of round chamfering. (Recommended height: 5 mm)
In addition, be aware that surfaces other than the body mounting reference plane (B dimension range) may slightly protrude from the body mounting reference plane. Be sure to provide a clearance of 1 mm or more to avoid interference with workpieces, facilities, etc.
- *2 This is the distance within which the table can move when it returns to origin.
Make sure that workpieces mounted on the table do not interfere with other workpieces or the facilities around the table.
- *3 Position after returning to origin
- *4 [] for when the direction of return to origin has changed

Dimensions

| Model | L | | A | B | n | D | E | F |
|---------------|--------------|-----------|-----|-----|----|---|-----|----|
| | Without lock | With lock | | | | | | |
| LEFS25G□-50□ | 285.5 | 330.5 | 56 | 160 | 4 | — | — | 35 |
| LEFS25G□-100□ | 335.5 | 380.5 | 106 | 210 | | | | |
| LEFS25G□-150□ | 385.5 | 430.5 | 156 | 260 | | | | |
| LEFS25G□-200□ | 435.5 | 480.5 | 206 | 310 | 6 | 2 | 240 | |
| LEFS25G□-250□ | 485.5 | 530.5 | 256 | 360 | | | | |
| LEFS25G□-300□ | 535.5 | 580.5 | 306 | 410 | 8 | 3 | 360 | |
| LEFS25G□-350□ | 585.5 | 630.5 | 356 | 460 | | | | |
| LEFS25G□-400□ | 635.5 | 680.5 | 406 | 510 | 10 | 4 | 480 | |
| LEFS25G□-450□ | 685.5 | 730.5 | 456 | 560 | | | | |
| LEFS25G□-500□ | 735.5 | 780.5 | 506 | 610 | 12 | 5 | 600 | |
| LEFS25G□-550□ | 785.5 | 830.5 | 556 | 660 | | | | |
| LEFS25G□-600□ | 835.5 | 880.5 | 606 | 710 | 14 | 6 | 720 | |
| LEFS25G□-650□ | 885.5 | 930.5 | 656 | 760 | | | | |
| LEFS25G□-700□ | 935.5 | 980.5 | 706 | 810 | 16 | 7 | 840 | |
| LEFS25G□-750□ | 985.5 | 1030.5 | 756 | 860 | | | | |
| LEFS25G□-800□ | 1035.5 | 1080.5 | 806 | 910 | | | | |

Dimensions: In-line Motor

LEFS25G

Positioning pin hole*1 (Option): Body bottom

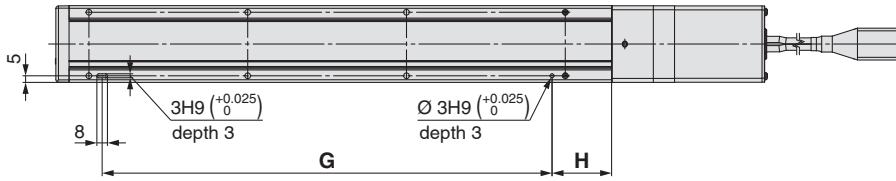

*1 When using the body bottom positioning pin holes, do not simultaneously use the housing B bottom pin hole.

With auto switch compatibility (Option)

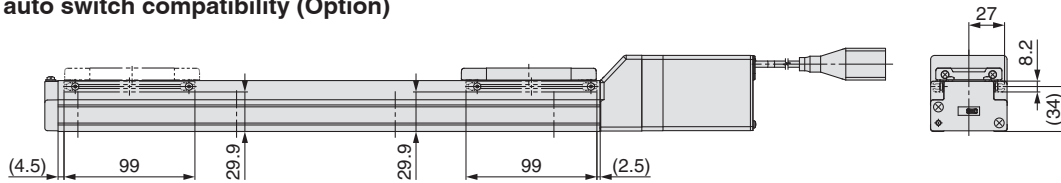

* For strokes of 99 mm or less, only 2 auto switch mounting brackets can be installed on the motor side.

| Dimensions | | [mm] |
|---------------|-----|------|
| Model | G | H |
| LEFS25G□-50□ | 100 | 30 |
| LEFS25G□-100□ | | |
| LEFS25G□-150□ | | |
| LEFS25G□-200□ | 220 | 45 |
| LEFS25G□-250□ | | |
| LEFS25G□-300□ | 340 | |
| LEFS25G□-350□ | | |
| LEFS25G□-400□ | 460 | |
| LEFS25G□-450□ | | |
| LEFS25G□-500□ | 580 | |
| LEFS25G□-550□ | | |
| LEFS25G□-600□ | 700 | |
| LEFS25G□-650□ | | |
| LEFS25G□-700□ | 820 | |
| LEFS25G□-750□ | | |
| LEFS25G□-800□ | | |

Dimensions: In-line Motor

LEFS32G

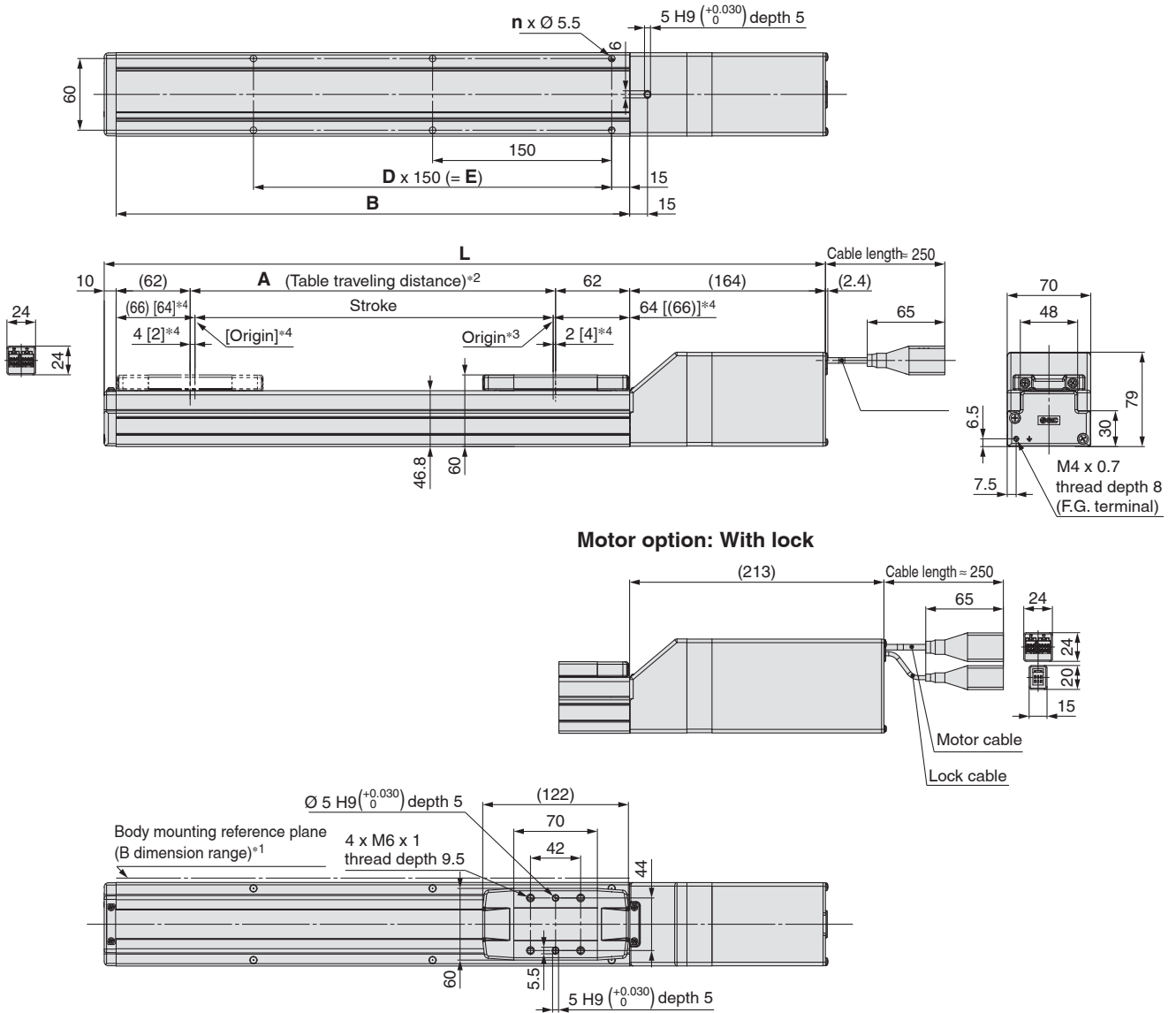

- *1 When mounting the actuator using the body mounting reference plane, set the height of the opposite surface or pin to be 3 mm or more. (Recommended height: 5 mm)
In addition, be aware that surfaces other than the body mounting reference plane (B dimension range) may slightly protrude from the body mounting reference plane. Be sure to provide a clearance of 1 mm or more to avoid interference with workpieces, facilities, etc.
- *2 This is the distance within which the table can move when it returns to origin.
Make sure that workpieces mounted on the table do not interfere with other workpieces or the facilities around the table.
- *3 Position after returning to origin
- *4 [] for when the direction of return to origin has changed

Dimensions

| Model | L | | A | B | n | D | E |
|----------------|--------------|-----------|------|------|----|---|------|
| | Without lock | With lock | | | | | |
| LEFS32G□-50□ | 354 | 403 | 56 | 180 | 4 | — | — |
| LEFS32G□-100□ | 404 | 453 | 106 | 230 | | | |
| LEFS32G□-150□ | 454 | 503 | 156 | 280 | | | |
| LEFS32G□-200□ | 504 | 553 | 206 | 330 | 6 | 2 | 300 |
| LEFS32G□-250□ | 554 | 603 | 256 | 380 | | | |
| LEFS32G□-300□ | 604 | 653 | 306 | 430 | | | |
| LEFS32G□-350□ | 654 | 703 | 356 | 480 | 8 | 3 | 450 |
| LEFS32G□-400□ | 704 | 753 | 406 | 530 | | | |
| LEFS32G□-450□ | 754 | 803 | 456 | 580 | | | |
| LEFS32G□-500□ | 804 | 853 | 506 | 630 | 10 | 4 | 600 |
| LEFS32G□-550□ | 854 | 903 | 556 | 680 | | | |
| LEFS32G□-600□ | 904 | 953 | 606 | 730 | | | |
| LEFS32G□-650□ | 954 | 1003 | 656 | 780 | 12 | 5 | 750 |
| LEFS32G□-700□ | 1004 | 1053 | 706 | 830 | | | |
| LEFS32G□-750□ | 1054 | 1103 | 756 | 880 | | | |
| LEFS32G□-800□ | 1104 | 1153 | 806 | 930 | 14 | 6 | 900 |
| LEFS32G□-850□ | 1154 | 1203 | 856 | 980 | | | |
| LEFS32G□-900□ | 1204 | 1253 | 906 | 1030 | | | |
| LEFS32G□-950□ | 1254 | 1303 | 956 | 1080 | 16 | 7 | 1050 |
| LEFS32G□-1000□ | 1304 | 1353 | 1006 | 1130 | | | |

Dimensions: In-line Motor

LEFS32G

Positioning pin hole*1 (Option): Body bottom

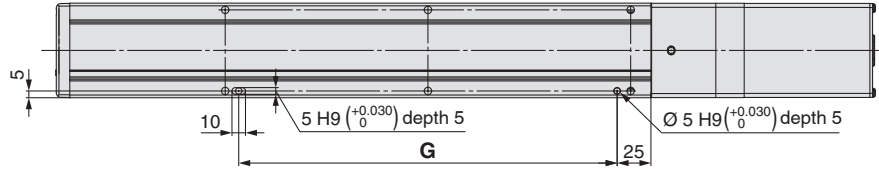

*1 When using the body bottom positioning pin holes, do not simultaneously use the housing B bottom pin hole.

With auto switch compatibility (Option)

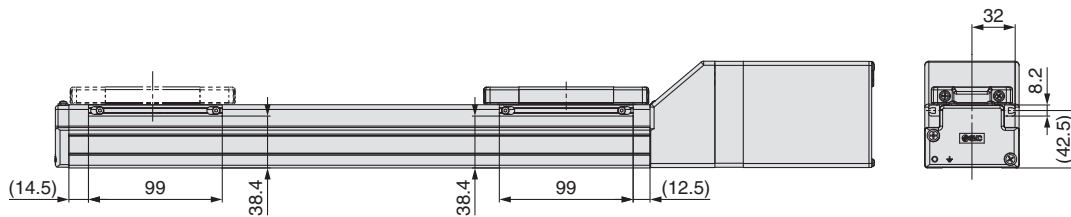

* For strokes of 99 mm or less, only 2 auto switch mounting brackets can be installed on the motor side.

| Dimensions [mm] | |
|-----------------|------|
| Model | G |
| LEFS32G□-50□ | 130 |
| LEFS32G□-100□ | |
| LEFS32G□-150□ | |
| LEFS32G□-200□ | 280 |
| LEFS32G□-250□ | |
| LEFS32G□-300□ | |
| LEFS32G□-350□ | 430 |
| LEFS32G□-400□ | |
| LEFS32G□-450□ | |
| LEFS32G□-500□ | 580 |
| LEFS32G□-550□ | |
| LEFS32G□-600□ | |
| LEFS32G□-650□ | 730 |
| LEFS32G□-700□ | |
| LEFS32G□-750□ | |
| LEFS32G□-800□ | 880 |
| LEFS32G□-850□ | |
| LEFS32G□-900□ | |
| LEFS32G□-950□ | 1030 |
| LEFS32G□-1000□ | |

Dimensions: In-line Motor

LEFS40G

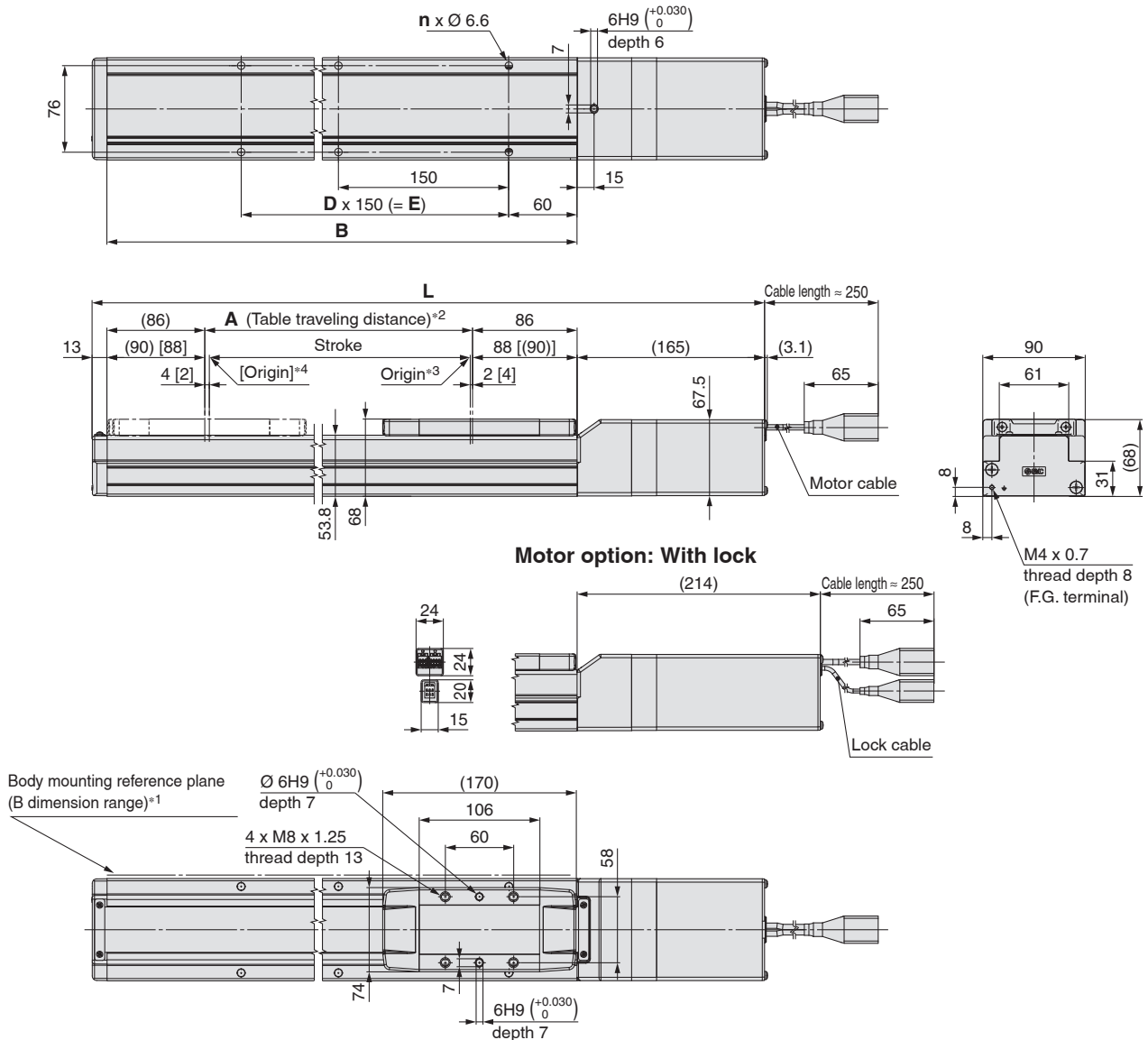

- *1 When mounting the actuator using the body mounting reference plane, set the height of the opposite surface or pin to be 3 mm or more because of round chamfering. (Recommended height: 5 mm)
In addition, be aware that surfaces other than the body mounting reference plane (B dimension range) may slightly protrude from the body mounting reference plane. Be sure to provide a clearance of 1 mm or more to avoid interference with workpieces, facilities, etc.
- *2 This is the distance within which the table can move when it returns to origin.
Make sure that workpieces mounted on the table do not interfere with other workpieces or the facilities around the table.
- *3 Position after returning to origin
- *4 [] for when the direction of return to origin has changed

Dimensions

| Model | L | | A | B | n | D | E |
|----------------|--------------|-----------|------|------|----|---|------|
| | Without lock | With lock | | | | | |
| LEFS40G□-150□ | 506 | 555 | 156 | 328 | 4 | — | 150 |
| LEFS40G□-200□ | 556 | 605 | 206 | 378 | 6 | 2 | 300 |
| LEFS40G□-250□ | 606 | 655 | 256 | 428 | | | |
| LEFS40G□-300□ | 656 | 705 | 306 | 478 | 8 | 3 | 450 |
| LEFS40G□-350□ | 706 | 755 | 356 | 528 | | | |
| LEFS40G□-400□ | 756 | 805 | 406 | 578 | 10 | 4 | 600 |
| LEFS40G□-450□ | 806 | 855 | 456 | 628 | | | |
| LEFS40G□-500□ | 856 | 905 | 506 | 678 | 12 | 5 | 750 |
| LEFS40G□-550□ | 906 | 955 | 556 | 728 | | | |
| LEFS40G□-600□ | 956 | 1005 | 606 | 778 | 14 | 6 | 900 |
| LEFS40G□-650□ | 1006 | 1055 | 656 | 828 | | | |
| LEFS40G□-700□ | 1056 | 1105 | 706 | 878 | 16 | 7 | 1050 |
| LEFS40G□-750□ | 1106 | 1155 | 756 | 928 | | | |
| LEFS40G□-800□ | 1156 | 1205 | 806 | 978 | 18 | 8 | 1200 |
| LEFS40G□-850□ | 1206 | 1255 | 856 | 1028 | | | |
| LEFS40G□-900□ | 1256 | 1305 | 906 | 1078 | | | |
| LEFS40G□-950□ | 1306 | 1355 | 956 | 1128 | | | |
| LEFS40G□-1000□ | 1356 | 1405 | 1006 | 1178 | | | |
| LEFS40G□-1100□ | 1456 | 1505 | 1106 | 1278 | | | |
| LEFS40G□-1200□ | 1556 | 1605 | 1206 | 1378 | | | |

Dimensions: In-line Motor

LEFS40G

Positioning pin hole*1 (Option): Body bottom

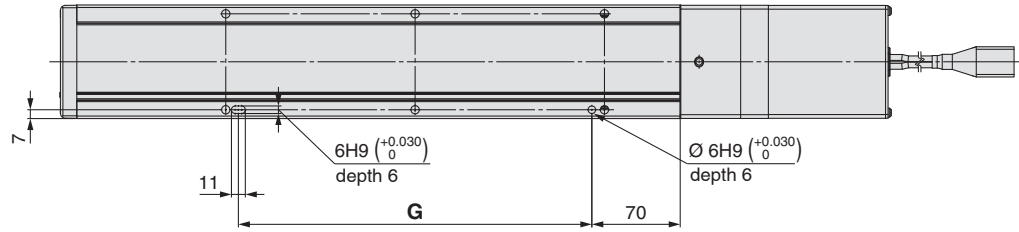

*1 When using the body bottom positioning pin holes, do not simultaneously use the housing B bottom pin hole.

With auto switch compatibility (Option)

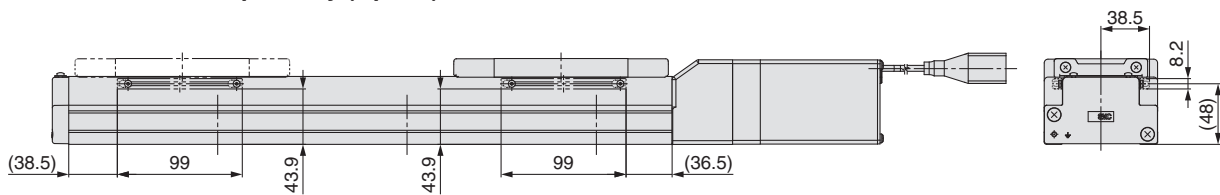

Dimensions [mm]

| Model | G |
|----------------|------|
| LEFS40G□-150□ | 130 |
| LEFS40G□-200□ | |
| LEFS40G□-250□ | 280 |
| LEFS40G□-300□ | |
| LEFS40G□-350□ | |
| LEFS40G□-400□ | 430 |
| LEFS40G□-450□ | |
| LEFS40G□-500□ | |
| LEFS40G□-550□ | 580 |
| LEFS40G□-600□ | |
| LEFS40G□-650□ | |
| LEFS40G□-700□ | 730 |
| LEFS40G□-750□ | |
| LEFS40G□-800□ | |
| LEFS40G□-850□ | 880 |
| LEFS40G□-900□ | |
| LEFS40G□-950□ | |
| LEFS40G□-1000□ | 1030 |
| LEFS40G□-1100□ | |
| LEFS40G□-1200□ | 1180 |

Dimensions: Motor Parallel

LEFS16RG

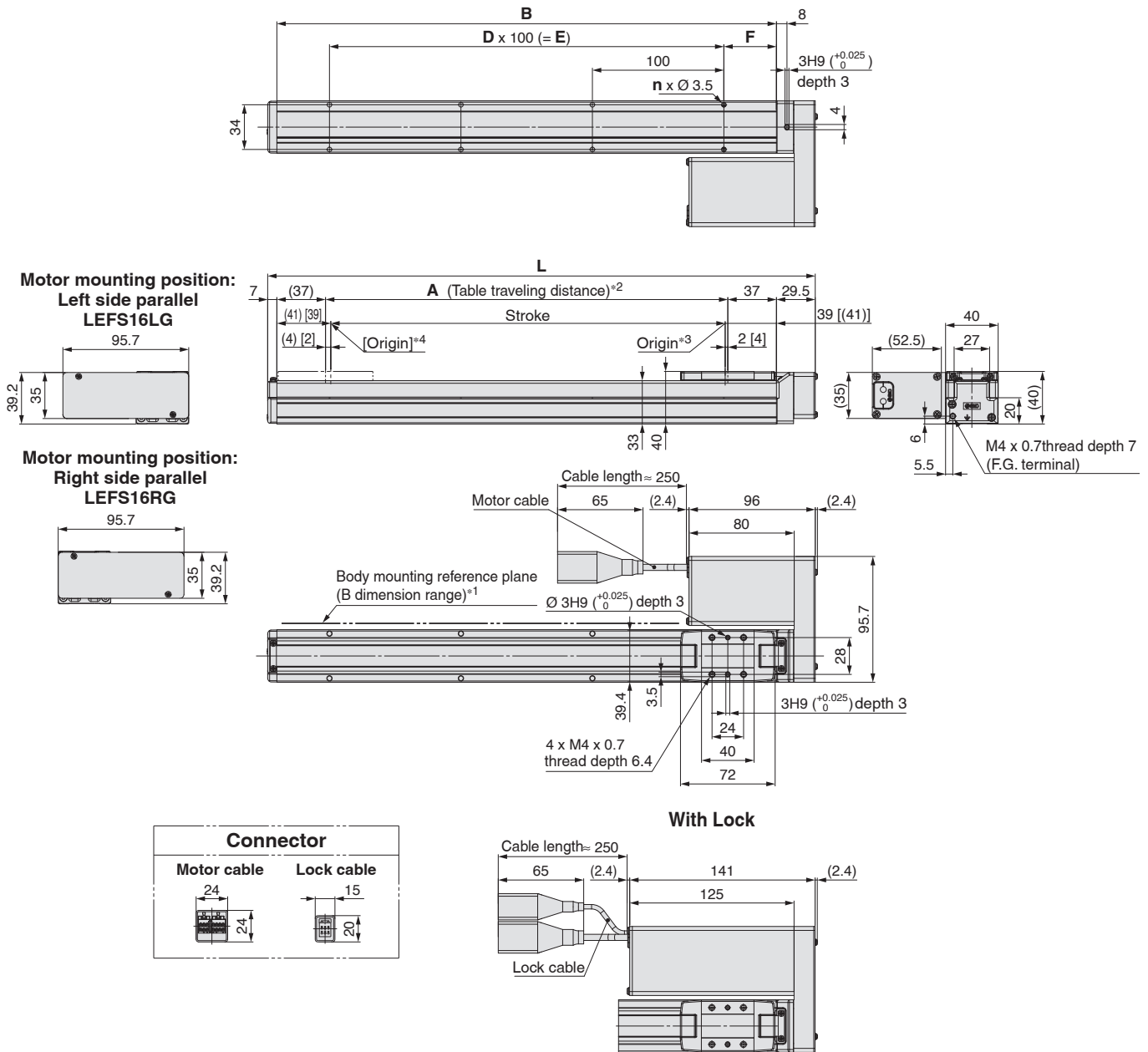

*1 When mounting the actuator using the body mounting reference plane, set the height of the opposite surface or pin to be 2 mm or more because of round chamfering. (Recommended height: 5 mm)
In addition, be aware that surfaces other than the body mounting reference plane (B dimension range) may slightly protrude from the body mounting reference plane. Be sure to provide a clearance of 1 mm or more to avoid interference with workpieces, facilities, etc.

*2 This is the distance within which the table can move when it returns to origin.
Make sure that workpieces mounted on the table do not interfere with other workpieces or the facilities around the table.

*3 Position after returning to origin

*4 [] for when the direction of return to origin has changed

Dimensions

| Model | L | A | B | n | D | E | F |
|----------------|-------|-----|-----|----|---|-----|----|
| LEFS16□G□-50□ | 166.5 | 56 | 130 | 4 | — | — | 15 |
| LEFS16□G□-100□ | 216.5 | 106 | 180 | | | | |
| LEFS16□G□-150□ | 266.5 | 156 | 230 | | | | |
| LEFS16□G□-200□ | 316.5 | 206 | 280 | 6 | 2 | 200 | 40 |
| LEFS16□G□-250□ | 366.5 | 256 | 330 | | | | |
| LEFS16□G□-300□ | 416.5 | 306 | 380 | 8 | 3 | 300 | |
| LEFS16□G□-350□ | 466.5 | 356 | 430 | | | | |
| LEFS16□G□-400□ | 516.5 | 406 | 480 | | | | |
| LEFS16□G□-450□ | 566.5 | 456 | 530 | 10 | 4 | 400 | |
| LEFS16□G□-500□ | 616.5 | 506 | 580 | | | | |

Dimensions: Motor Parallel

LEFS16RG

Positioning pin hole*1 (Option): Body bottom

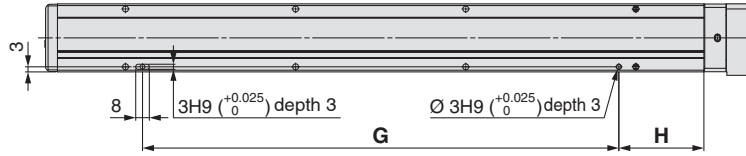

*1 When using the body bottom positioning pin holes, do not simultaneously use the housing B bottom pin hole.

Dimensions

| Model | Positioning pin hole: K | |
|----------------|--------------------------------|----------|
| | G | H |
| LEFS16□G□-50□ | 80 | 25 |
| LEFS16□G□-100□ | | 50 |
| LEFS16□G□-150□ | | |
| LEFS16□G□-200□ | | |
| LEFS16□G□-250□ | | |
| LEFS16□G□-300□ | | |
| LEFS16□G□-350□ | | |
| LEFS16□G□-400□ | | |
| LEFS16□G□-450□ | | |
| LEFS16□G□-500□ | 480 | |

Dimensions: Motor Parallel

LEFS25RG

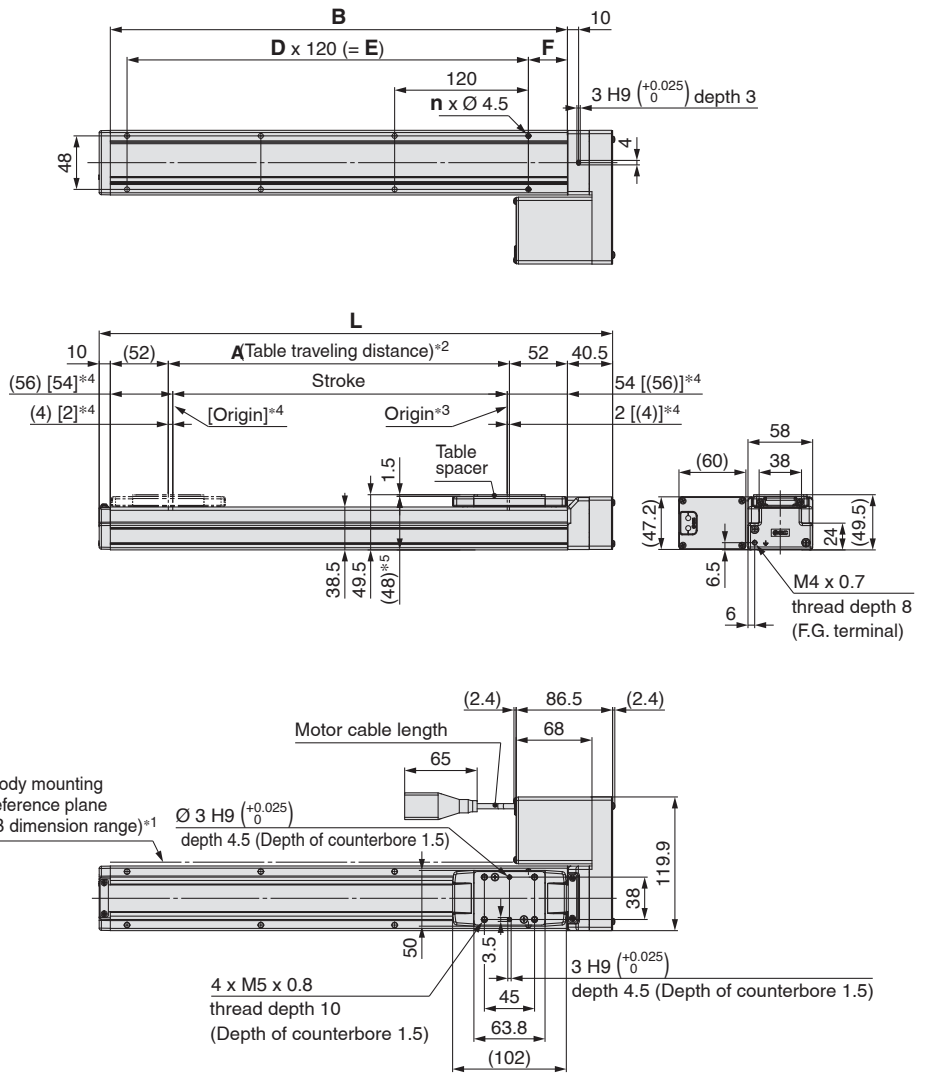
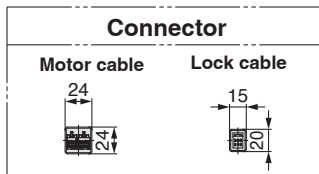
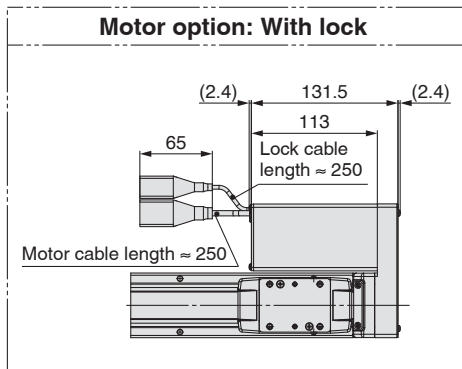
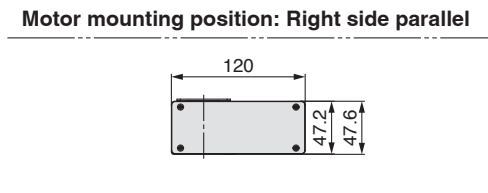
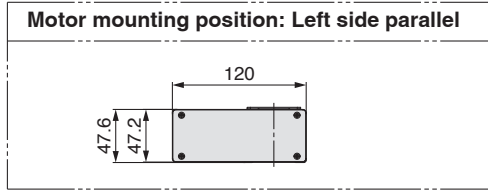

- *1 When mounting the actuator using the body mounting reference plane, set the height of the opposite surface or pin to be 3 mm or more. (Recommended height: 5 mm)
In addition, be aware that surfaces other than the body mounting reference plane (B dimension range) may slightly protrude from the body mounting reference plane. Be sure to provide a clearance of 1 mm or more to avoid interference with workpieces, facilities, etc.
- *2 This is the distance within which the table can move when it returns to origin.
Make sure that workpieces mounted on the table do not interfere with other workpieces or the facilities around the table.
- *3 Position after returning to origin
- *4 [] for when the direction of return to origin has changed
- *5 When the table spacer is removed

| Dimensions | [mm] | | | | | | | |
|----------------|-------|-----|-----|---|---|-----|----|----|
| Model | L | A | B | n | D | E | F | |
| LEFS25□G□-50□ | 210.5 | 56 | 160 | 4 | — | — | 20 | 35 |
| LEFS25□G□-100□ | 260.5 | 106 | 210 | | | | | |
| LEFS25□G□-150□ | 310.5 | 156 | 260 | | | | | |
| LEFS25□G□-200□ | 360.5 | 206 | 310 | 6 | 2 | 240 | | |
| LEFS25□G□-250□ | 410.5 | 256 | 360 | | | | | |
| LEFS25□G□-300□ | 460.5 | 306 | 410 | | | | | |
| LEFS25□G□-350□ | 510.5 | 356 | 460 | 8 | 3 | 360 | | |
| LEFS25□G□-400□ | 560.5 | 406 | 510 | | | | | |

| Dimensions | [mm] | | | | | | | |
|----------------|-------|-----|-----|----|---|-----|----|--|
| Model | L | A | B | n | D | E | F | |
| LEFS25□G□-450□ | 610.5 | 456 | 560 | 10 | 4 | 480 | 35 | |
| LEFS25□G□-500□ | 660.5 | 506 | 610 | | | | | |
| LEFS25□G□-550□ | 710.5 | 556 | 660 | | | | | |
| LEFS25□G□-600□ | 760.5 | 606 | 710 | 12 | 5 | 600 | | |
| LEFS25□G□-650□ | 810.5 | 656 | 760 | | | | | |
| LEFS25□G□-700□ | 860.5 | 706 | 810 | | | | | |
| LEFS25□G□-750□ | 910.5 | 756 | 860 | 14 | 6 | 720 | | |
| LEFS25□G□-800□ | 960.5 | 806 | 910 | | | | | |

Dimensions: Motor Parallel

LEFS25RG

Positioning pin hole*1 (Option): Body bottom

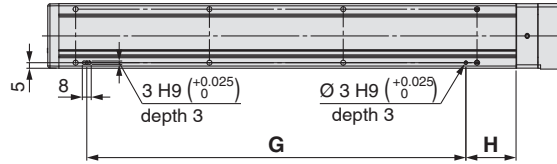

*1 When using the body bottom positioning pin holes, do not simultaneously use the housing B bottom pin hole.

| Model | [mm] | |
|----------------|------|----|
| | G | H |
| LEFS25□G□-50□ | 100 | 30 |
| LEFS25□G□-100□ | | 45 |
| LEFS25□G□-150□ | | |
| LEFS25□G□-200□ | | |
| LEFS25□G□-250□ | | |
| LEFS25□G□-300□ | | |
| LEFS25□G□-350□ | | |
| LEFS25□G□-400□ | | |
| LEFS25□G□-450□ | | |
| LEFS25□G□-500□ | | |
| LEFS25□G□-550□ | 700 | |
| LEFS25□G□-600□ | | |
| LEFS25□G□-650□ | | |
| LEFS25□G□-700□ | | |
| LEFS25□G□-750□ | 820 | |
| LEFS25□G□-800□ | | |

Dimensions: Motor Parallel

LEFS32RG

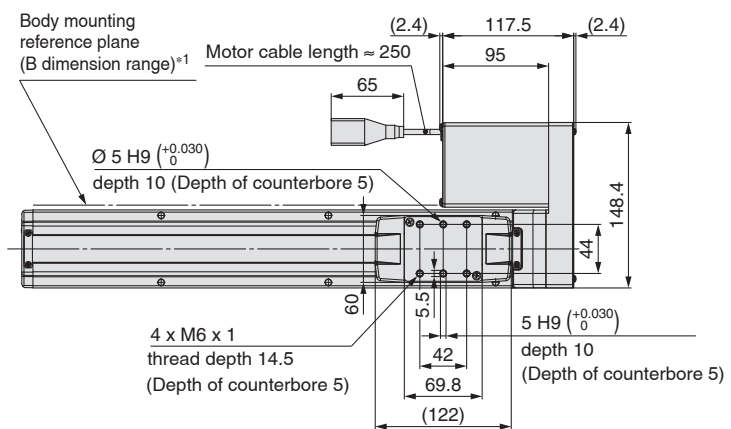
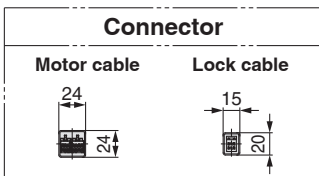
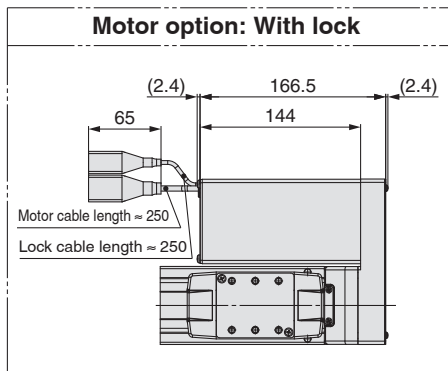
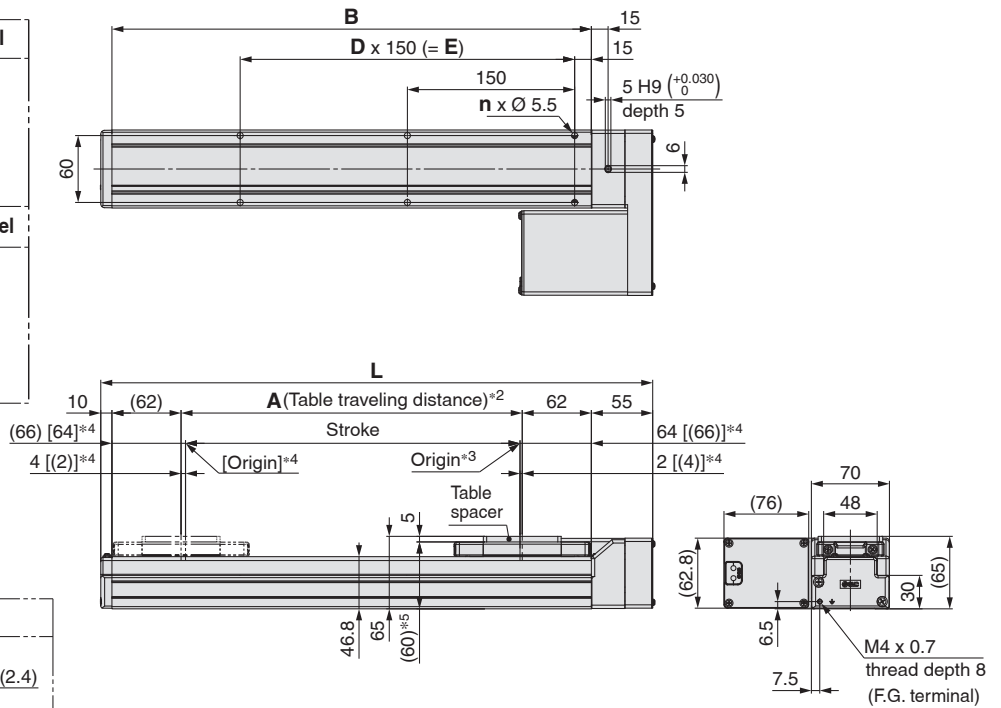
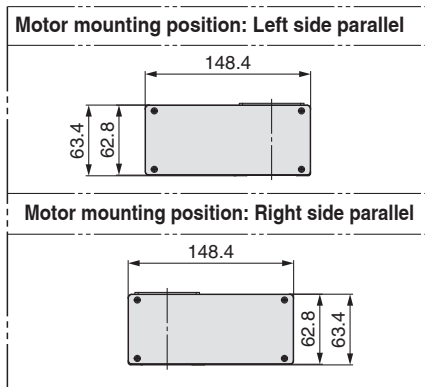

- *1 When mounting the actuator using the body mounting reference plane, set the height of the opposite surface or pin to be 3 mm or more. (Recommended height: 5 mm)
In addition, be aware that surfaces other than the body mounting reference plane (B dimension range) may slightly protrude from the body mounting reference plane. Be sure to provide a clearance of 1 mm or more to avoid interference with workpieces, facilities, etc.
- *2 This is the distance within which the table can move when it returns to origin.
Make sure that workpieces mounted on the table do not interfere with other workpieces or the facilities around the table.
- *3 Position after returning to origin
- *4 [] for when the direction of return to origin has changed
- *5 When the table spacer is removed

| Dimensions | [mm] | | | | | | |
|----------------|------|-----|-----|----|---|-----|---|
| Model | L | A | B | n | D | E | |
| LEFS32□G□-50□ | 245 | 56 | 180 | 4 | — | — | — |
| LEFS32□G□-100□ | 295 | 106 | 230 | | | | |
| LEFS32□G□-150□ | 345 | 156 | 280 | | | | |
| LEFS32□G□-200□ | 395 | 206 | 330 | 6 | 2 | 300 | — |
| LEFS32□G□-250□ | 445 | 256 | 380 | | | | |
| LEFS32□G□-300□ | 495 | 306 | 430 | | | | |
| LEFS32□G□-350□ | 545 | 356 | 480 | 8 | 3 | 450 | — |
| LEFS32□G□-400□ | 595 | 406 | 530 | | | | |
| LEFS32□G□-450□ | 645 | 456 | 580 | | | | |
| LEFS32□G□-500□ | 695 | 506 | 630 | 10 | 4 | 600 | — |

| Dimensions | [mm] | | | | | | |
|-----------------|------|------|------|----|---|------|---|
| Model | L | A | B | n | D | E | |
| LEFS32□G□-550□ | 745 | 556 | 680 | 10 | 4 | 600 | — |
| LEFS32□G□-600□ | 795 | 606 | 730 | | | | |
| LEFS32□G□-650□ | 845 | 656 | 780 | | | | |
| LEFS32□G□-700□ | 895 | 706 | 830 | 12 | 5 | 750 | — |
| LEFS32□G□-750□ | 945 | 756 | 880 | | | | |
| LEFS32□G□-800□ | 995 | 806 | 930 | | | | |
| LEFS32□G□-850□ | 1045 | 856 | 980 | 14 | 6 | 900 | — |
| LEFS32□G□-900□ | 1095 | 906 | 1030 | | | | |
| LEFS32□G□-950□ | 1145 | 956 | 1080 | | | | |
| LEFS32□G□-1000□ | 1195 | 1006 | 1130 | 16 | 7 | 1050 | — |

Dimensions: Motor Parallel

LEFS32RG

Positioning pin hole*1 (Option): Body bottom

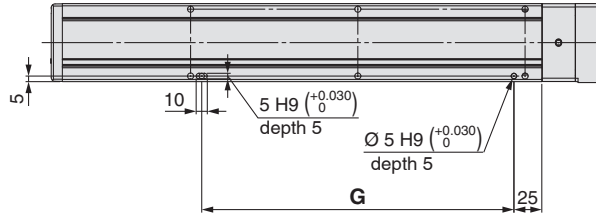

*1 When using the body bottom positioning pin holes, do not simultaneously use the housing B bottom pin hole.

| Dimensions | | [mm] |
|-----------------|------|------|
| Model | G | |
| LEFS32□G□-50□ | 130 | |
| LEFS32□G□-100□ | 130 | |
| LEFS32□G□-150□ | 130 | |
| LEFS32□G□-200□ | 280 | |
| LEFS32□G□-250□ | 280 | |
| LEFS32□G□-300□ | 280 | |
| LEFS32□G□-350□ | 430 | |
| LEFS32□G□-400□ | 430 | |
| LEFS32□G□-450□ | 430 | |
| LEFS32□G□-500□ | 580 | |
| LEFS32□G□-550□ | 580 | |
| LEFS32□G□-600□ | 580 | |
| LEFS32□G□-650□ | 730 | |
| LEFS32□G□-700□ | 730 | |
| LEFS32□G□-750□ | 730 | |
| LEFS32□G□-800□ | 880 | |
| LEFS32□G□-850□ | 880 | |
| LEFS32□G□-900□ | 880 | |
| LEFS32□G□-950□ | 1030 | |
| LEFS32□G□-1000□ | 1030 | |

Dimensions: Motor Parallel

LEFS40RG

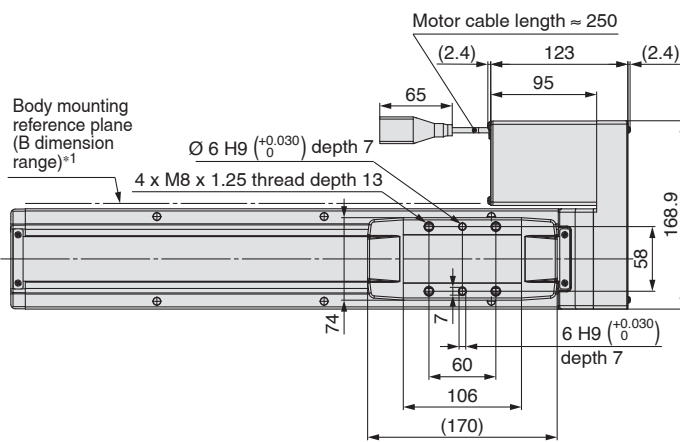
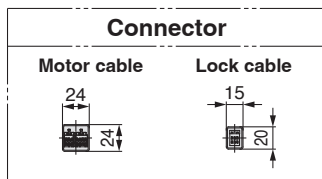
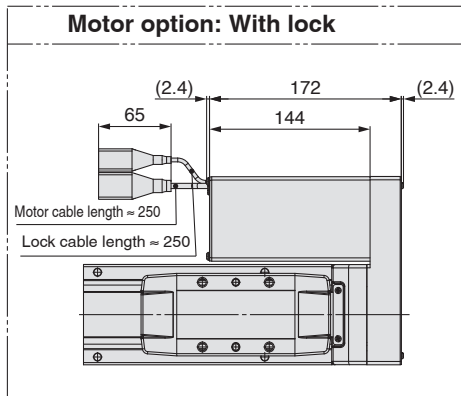
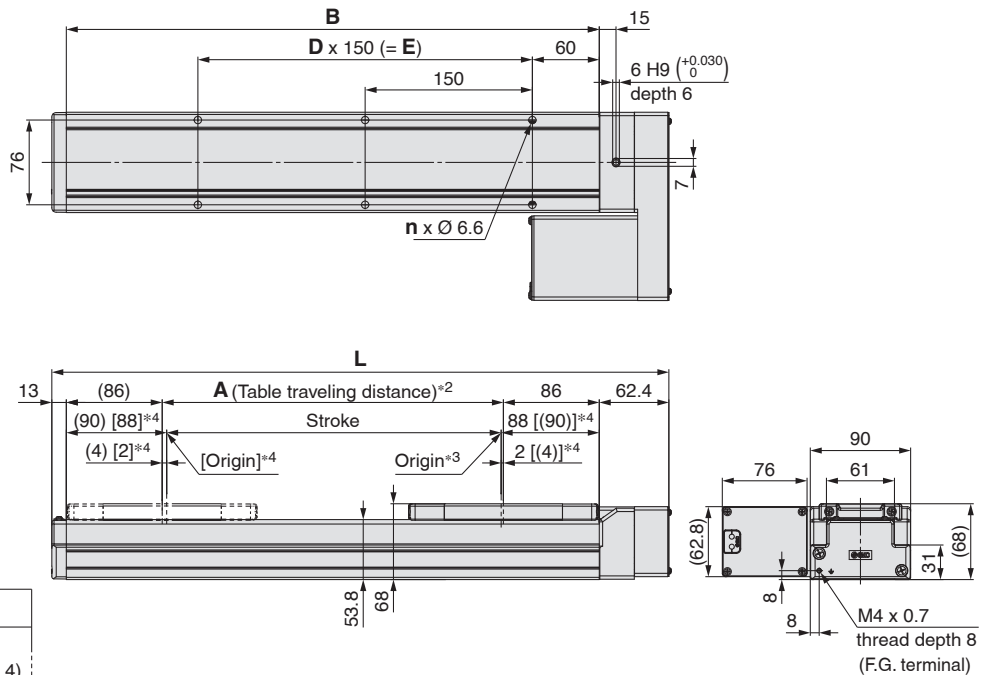
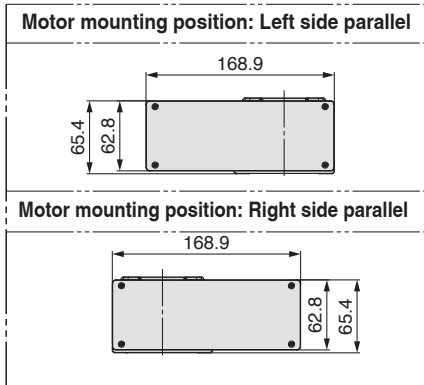

- *1 When mounting the actuator using the body mounting reference plane, set the height of the opposite surface or pin to be 3 mm or more. (Recommended height: 5 mm)
In addition, be aware that surfaces other than the body mounting reference plane (B dimension range) may slightly protrude from the body mounting reference plane. Be sure to provide a clearance of 1 mm or more to avoid interference with workpieces, facilities, etc.
- *2 This is the distance within which the table can move when it returns to origin.
Make sure that workpieces mounted on the table do not interfere with other workpieces or the facilities around the table.
- *3 Position after returning to origin
- *4 [] for when the direction of return to origin has changed

| Model | L | A | B | n | D | E |
|----------------|-------|-----|-----|----|---|-----|
| LEFS40□G□-150□ | 403.4 | 156 | 328 | 4 | — | — |
| LEFS40□G□-200□ | 453.4 | 206 | 378 | 6 | 2 | 300 |
| LEFS40□G□-250□ | 503.4 | 256 | 428 | | | |
| LEFS40□G□-300□ | 553.4 | 306 | 478 | 8 | 3 | 450 |
| LEFS40□G□-350□ | 603.4 | 356 | 528 | | | |
| LEFS40□G□-400□ | 653.4 | 406 | 578 | 10 | 4 | 600 |
| LEFS40□G□-450□ | 703.4 | 456 | 628 | | | |
| LEFS40□G□-500□ | 753.4 | 506 | 678 | 10 | 4 | 600 |
| LEFS40□G□-550□ | 803.4 | 556 | 728 | | | |
| LEFS40□G□-600□ | 853.4 | 606 | 778 | | | |

| Model | L | A | B | n | D | E |
|-----------------|--------|------|------|----|---|------|
| LEFS40□G□-650□ | 903.4 | 656 | 828 | 12 | 5 | 750 |
| LEFS40□G□-700□ | 953.4 | 706 | 878 | | | |
| LEFS40□G□-750□ | 1003.4 | 756 | 928 | 14 | 6 | 900 |
| LEFS40□G□-800□ | 1053.4 | 806 | 978 | | | |
| LEFS40□G□-850□ | 1103.4 | 856 | 1028 | 16 | 7 | 1050 |
| LEFS40□G□-900□ | 1153.4 | 906 | 1078 | | | |
| LEFS40□G□-950□ | 1203.4 | 956 | 1128 | 18 | 8 | 1200 |
| LEFS40□G□-1000□ | 1253.4 | 1006 | 1178 | | | |
| LEFS40□G□-1100□ | 1353.4 | 1106 | 1278 | | | |
| LEFS40□G□-1200□ | 1453.4 | 1206 | 1378 | | | |

Dimensions: Motor Parallel

LEFS40RG

Positioning pin hole*1 (Option): Body bottom

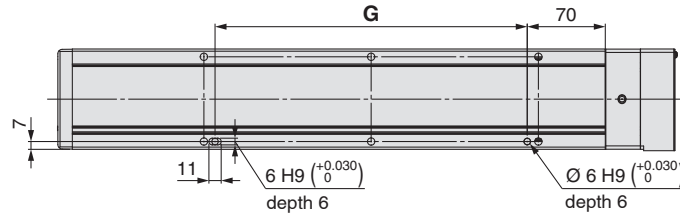

*1 When using the body bottom positioning pin holes, do not simultaneously use the housing B bottom pin hole.

| Dimensions | | [mm] |
|-----------------|------|------|
| Model | G | |
| LEFS40□G□-150□ | 130 | |
| LEFS40□G□-200□ | | |
| LEFS40□G□-250□ | 280 | |
| LEFS40□G□-300□ | | |
| LEFS40□G□-350□ | | |
| LEFS40□G□-400□ | 430 | |
| LEFS40□G□-450□ | | |
| LEFS40□G□-500□ | | |
| LEFS40□G□-550□ | 580 | |
| LEFS40□G□-600□ | | |
| LEFS40□G□-650□ | | |
| LEFS40□G□-700□ | 730 | |
| LEFS40□G□-750□ | | |
| LEFS40□G□-800□ | | |
| LEFS40□G□-850□ | 880 | |
| LEFS40□G□-900□ | | |
| LEFS40□G□-950□ | | |
| LEFS40□G□-1000□ | 1030 | |
| LEFS40□G□-1100□ | | |
| LEFS40□G□-1200□ | 1180 | |

LEFS□G Series Auto Switch Mounting

Auto Switch Mounting Position

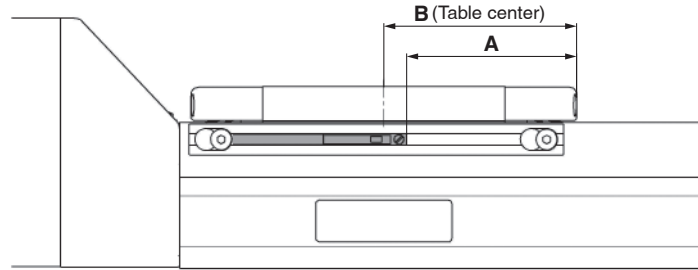

| [mm] | | | | |
|--------|------|----|----|-----------------|
| Model | Size | A | B | Operating range |
| LEFS□G | 25 | 45 | 51 | 4.9 |
| | 32 | 55 | 61 | 3.9 |
| | 40 | 79 | 85 | 5.3 |

- * The applicable auto switch is D-M9 (N/P/B) (W) (M/L/Z).
- * The operating range is a guideline including hysteresis, not meant to be guaranteed. There may be large variations depending on the ambient environment.
- * Adjust the auto switch after confirming the operating conditions in the actual setting.

Auto Switch Mounting

Rotate the bolts for the auto switch mounting bracket three to four times to loosen them (Removing them is not required), and slide and remove the auto switch mounting bracket. Then, insert a switch into the groove on the mounting bracket.

As the mounting bolts for installing the product body interfere with the auto switch mounting bracket, mount the auto switch mounting bracket after installing the product body. After setting in the mounting position, use a flat head watchmaker's screwdriver to tighten the auto switch mounting screw that is included.

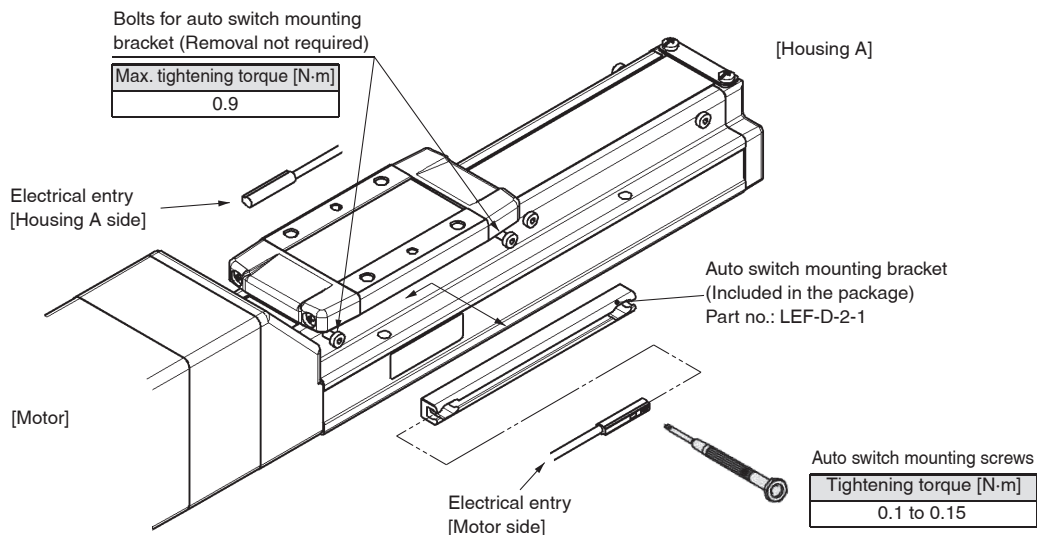

- * The applicable auto switch is D-M9 (N/P/B) (W) (M/L/Z).
- * The direction of the lead wire entry is specified. If it is mounted in the opposite direction, the auto switch may malfunction.
- * When tightening the auto switch mounting screw (included with the auto switch), use a watchmaker's screwdriver with a handle diameter of about 5 to 6 mm.
- * If more than two auto switch mounting brackets are required, please order them separately. All eight bolts for attaching the auto switch mounting bracket at the stroke end are tightened into the body when the product is shipped.
For 50-mm stroke type, only four bolts are tightened on the motor side.

Solid State Auto Switch Direct Mounting Type D-M9N/D-M9P/D-M9B



Refer to the SMC website for details on products that are compliant with international standards.

Grommet

- 2-wire load current is reduced (2.5 to 40 mA).
- Using flexible cable as standard spec.



Caution

Precautions

Fix the auto switch with the existing screw installed on the auto switch body. The auto switch may be damaged if a screw other than the one supplied is used.

Auto Switch Specifications

PLC: Programmable Logic Controller

| D-M9□, D-M9□V (With indicator light) | | | |
|--------------------------------------|---|-------|-----------------------|
| Auto switch model | D-M9N | D-M9P | D-M9B |
| Electrical entry direction | In-line | | |
| Wiring type | 3-wire | | 2-wire |
| Output type | NPN | PNP | — |
| Applicable load | IC circuit, Relay, PLC | | 24 VDC relay, PLC |
| Power supply voltage | 5, 12, 24 VDC (4.5 to 28 V) | | — |
| Current consumption | 10 mA or less | | — |
| Load voltage | 28 VDC or less | — | 24 VDC (10 to 28 VDC) |
| Load current | 40 mA or less | | 2.5 to 40 mA |
| Internal voltage drop | 0.8 V or less at 10 mA (2 V or less at 40 mA) | | 4 V or less |
| Leakage current | 100 μA or less at 24 VDC | | 0.8 mA or less |
| Indicator light | Red LED illuminates when turned ON. | | |
| Standard | CE marking, RoHS | | |

Oilproof Flexible Heavy-duty Lead Wire Specifications

| Auto switch model | | D-M9N | D-M9P | D-M9B |
|--|-----------------------------------|----------------------------|-------|----------------------|
| Sheath | Outside diameter [mm] | 2.6 | | |
| Insulator | Number of cores | 3 cores (Brown/Blue/Black) | | 2 cores (Brown/Blue) |
| | Outside diameter [mm] | 0.88 | | |
| Conductor | Effective area [mm ²] | 0.15 | | |
| | Strand diameter [mm] | 0.05 | | |
| Minimum bending radius [mm] (Reference values) | | 17 | | |

- * Refer to the **Web Catalogue** for solid state auto switch common specifications.
- * Refer to the **Web Catalogue** for lead wire lengths.

Weight

[g]

| Auto switch model | | D-M9N | D-M9P | D-M9B |
|-------------------|-----------|-------|-------|-------|
| Lead wire length | 0.5 m (—) | 8 | — | 7 |
| | 1 m (M) | 14 | — | 13 |
| | 3 m (L) | 41 | — | 38 |
| | 5 m (Z) | 68 | — | 63 |

Dimensions

[mm]

D-M9□

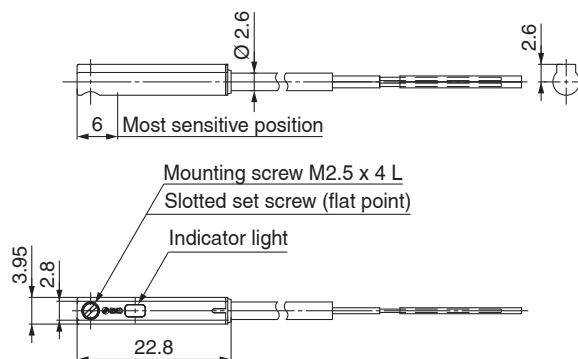

Normally Closed Solid State Auto Switch Direct Mounting Type

D-M9NE(V)/D-M9PE(V)/D-M9BE(V)

Refer to the SMC website for details on products that are compliant with international standards.

Auto Switch Specifications

PLC: Programmable Logic Controller

| D-M9□E, D-M9□EV (With indicator light) | | | | | | |
|--|---|---------------|---------|---------------|-----------------------|---------------|
| Auto switch model | D-M9NE | D-M9NEV | D-M9PE | D-M9PEV | D-M9BE | D-M9BEV |
| Electrical entry direction | In-line | Perpendicular | In-line | Perpendicular | In-line | Perpendicular |
| Wiring type | 3-wire | | | | 2-wire | |
| Output type | NPN | | PNP | | — | |
| Applicable load | IC circuit, Relay, PLC | | | | 24 VDC relay, PLC | |
| Power supply voltage | 5, 12, 24 VDC (4.5 to 28 V) | | | | — | |
| Current consumption | 10 mA or less | | | | — | |
| Load voltage | 28 VDC or less | | — | | 24 VDC (10 to 28 VDC) | |
| Load current | 40 mA or less | | | | 2.5 to 40 mA | |
| Internal voltage drop | 0.8 V or less at 10 mA (2 V or less at 40 mA) | | | | 4 V or less | |
| Leakage current | 100 μA or less at 24 VDC | | | | 0.8 mA or less | |
| Indicator light | Red LED illuminates when turned ON. | | | | | |
| Standard | CE marking, RoHS | | | | | |

Grommet

- Output signal turns on when no magnetic force is detected.
- Can be used for the actuator adopted by the solid state auto switch D-M9 series (excluding special order products)



Oilproof Flexible Heavy-duty Lead Wire Specifications

| Auto switch model | D-M9NE(V) | D-M9PE(V) | D-M9BE(V) |
|--|-----------------------------------|-----------|----------------------|
| Sheath | Outside diameter [mm] | | |
| | 2.6 | | |
| Insulator | Number of cores | | 2 cores (Brown/Blue) |
| | Outside diameter [mm] | | 0.88 |
| Conductor | Effective area [mm ²] | | 0.15 |
| | Strand diameter [mm] | | 0.05 |
| Minimum bending radius [mm] (Reference values) | | | |
| 17 | | | |

- * Refer to the **Web Catalogue** for solid state auto switch common specifications.
- * Refer to the **Web Catalogue** for lead wire lengths.

Caution

Precautions

Fix the auto switch with the existing screw installed on the auto switch body. The auto switch may be damaged if a screw other than the one supplied is used.

Weight

[g]

| Auto switch model | D-M9NE(V) | D-M9PE(V) | D-M9BE(V) |
|-------------------|-----------|-----------|-----------|
| Lead wire length | 0.5 m (—) | 8 | 7 |
| | 1 m (M)*1 | 14 | 13 |
| | 3 m (L) | 41 | 38 |
| | 5 m (Z)*1 | 68 | 63 |

*1 The 1 m and 5 m options are produced upon receipt of order.

Dimensions

[mm]

D-M9□E

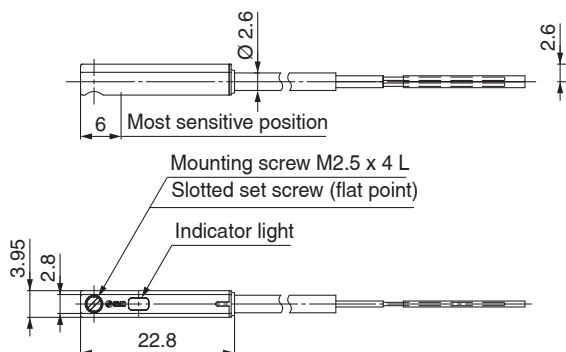

D-M9□EV

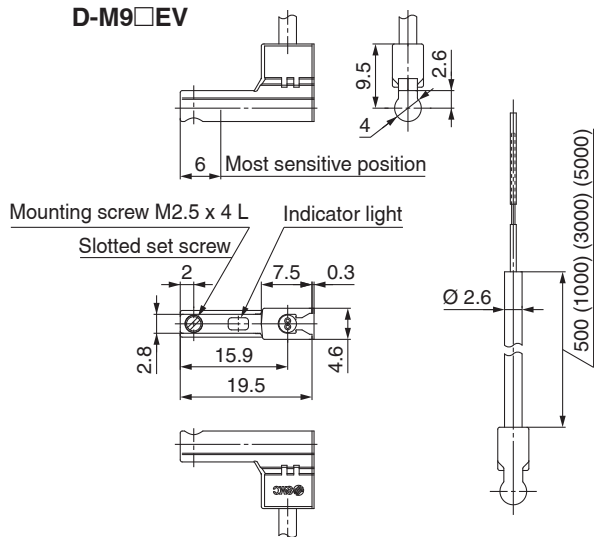

2-Colour Indicator Solid State Auto Switch Direct Mounting Type

D-M9NW/D-M9PW/D-M9BW



Refer to the SMC website for details on products that are compliant with international standards.

Grommet

- 2-wire load current is reduced (2.5 to 40 mA).
- Using flexible cable as standard spec.
- The proper operating range can be determined by the colour of the light. (Red → Green ← Red)



Caution

Precautions

Fix the auto switch with the existing screw installed on the auto switch body. The auto switch may be damaged if a screw other than the one supplied is used.

Auto Switch Specifications

PLC: Programmable Logic Controller

| D-M9□W, D-M9□WV (With indicator light) | | | |
|--|---|--------|-----------------------|
| Auto switch model | D-M9NW | D-M9PW | D-M9BW |
| Electrical entry direction | In-line | | |
| Wiring type | 3-wire | | 2-wire |
| Output type | NPN | PNP | — |
| Applicable load | IC circuit, Relay, PLC | | 24 VDC relay, PLC |
| Power supply voltage | 5, 12, 24 VDC (4.5 to 28 V) | | — |
| Current consumption | 10 mA or less | | |
| Load voltage | 28 VDC or less | — | 24 VDC (10 to 28 VDC) |
| Load current | 40 mA or less | | 2.5 to 40 mA |
| Internal voltage drop | 0.8 V or less at 10 mA (2 V or less at 40 mA) | | 4 V or less |
| Leakage current | 100 μA or less at 24 VDC | | 0.8 mA or less |
| Indicator light | Operating range Red LED illuminates. Proper operating range Green LED illuminates. | | |
| Standard | CE marking, RoHS | | |

Oilproof Flexible Heavy-duty Lead Wire Specifications

| Auto switch model | | D-M9NW | D-M9PW | D-M9BW |
|--|-----------------------------------|----------------------------|--------|----------------------|
| Sheath | Outside diameter [mm] | 2.6 | | |
| Insulator | Number of cores | 3 cores (Brown/Blue/Black) | | 2 cores (Brown/Blue) |
| | Outside diameter [mm] | 0.88 | | |
| Conductor | Effective area [mm ²] | 0.15 | | |
| | Strand diameter [mm] | 0.05 | | |
| Minimum bending radius [mm] (Reference values) | | 17 | | |

- * Refer to the **Web Catalogue** for solid state auto switch common specifications.
- * Refer to the **Web Catalogue** for lead wire lengths.

Weight

[g]

| Auto switch model | | D-M9NW | D-M9PW | D-M9BW |
|-------------------|-----------|--------|--------|--------|
| Lead wire length | 0.5 m (—) | 8 | 7 | 7 |
| | 1 m (M) | 14 | 13 | 13 |
| | 3 m (L) | 41 | 38 | 38 |
| | 5 m (Z) | 68 | 63 | 63 |

Dimensions

[mm]

D-M9□W

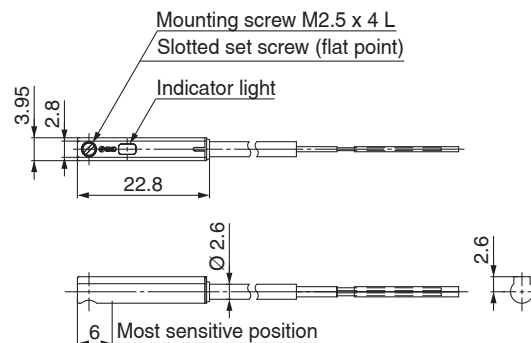

Controllers

JXC□ Series

Step Data Input Type p. 43

High Performance

Battery-less Absolute (Step Motor 24 VDC)

JXC5H/6H Series



EtherCAT/EtherNet/IP™/PROFINET p. 50

High Performance

Battery-less Absolute (Step Motor 24 VDC)

JXCEH/9H/PH Series

EtherCAT®

EtherNet/IP™

PROFINET®



- Actuator Cable **p. 55**

High Performance Controller (Step Data Input Type)

JXC5H/6H Series



How to Order

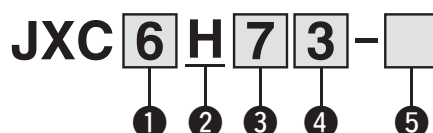

1 Controller type

| | |
|---|-------------------------|
| 5 | Parallel I/O (NPN) type |
| 6 | Parallel I/O (PNP) type |

2 Specification

| | |
|---|-----------------------|
| H | High performance type |
|---|-----------------------|

3 Mounting

| | |
|---|----------------|
| 7 | Screw mounting |
| 8 | DIN rail |

4 I/O cable length

| | |
|---|-------|
| — | None |
| 1 | 1.5 m |
| 3 | 3 m |
| 5 | 5 m |

5 Actuator part number

Without cable specifications and actuator options
Example: Enter "LEFS25GA-100" for the
LEFS25GA-100B-R1□.

| | |
|----|--------------------|
| BC | Blank controller*1 |
|----|--------------------|

*1 Requires dedicated software (JXC-BCW)

The controller is sold as single unit after the compatible actuator is set.

Connect to an actuator (LEFS□G) designated for a high performance controller. Confirm that the combination of the controller and actuator is correct.

<Check the following before use.>

- ① Check the actuator label for the model number. This number should match that of the controller.
- ② Check that the Parallel I/O configuration matches (NPN or PNP).

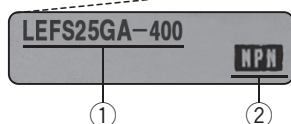

⚠ Caution

[CE/UKCA-compliant products]

EMC compliance was tested by combining the electric actuator LE series and the JXC5H/6H series.

The EMC depends on the configuration of the customer's control panel and the relationship with other electrical equipment and wiring.

Therefore, compliance with the EMC directive cannot be certified for SMC components incorporated into the customer's equipment under actual operating conditions. As a result, it is necessary for the customer to verify compliance with the EMC directive for the machinery and equipment as a whole.

* Refer to the operation manual for using the products. Please download it via our website:
<https://www.smc.eu>

Specifications

| Model | JXC5H JXC6H |
|-----------------------------------|---|
| Compatible motor | Step motor (Servo/24 VDC) |
| Power supply | Power supply voltage: 24 VDC ±10 % |
| Current consumption (Controller) | 100 mA or less |
| Compatible encoder | Battery-less absolute encoder |
| Parallel input | 11 inputs (Photo-coupler isolation) |
| Parallel output | 13 outputs (Photo-coupler isolation) |
| Serial communication | RS485 (Only for the LEC-T1 and JXC-W2) |
| Memory | EEPROM |
| LED indicator | PWR, ALM |
| Cable length [m] | Actuator cable: 20 or less |
| Cooling system | Natural air cooling |
| Operating temperature range [°C] | 0 to 40 |
| Operating humidity range [%RH] | 90 or less (No condensation) |
| Insulation resistance [MΩ] | Between all external terminals and the case: 50 (500 VDC) |
| Weight [g] | 150 (Screw mounting), 170 (DIN rail mounting) |

How to Mount

a) Screw mounting (JXC□H7□) (Installation with two M4 screws)

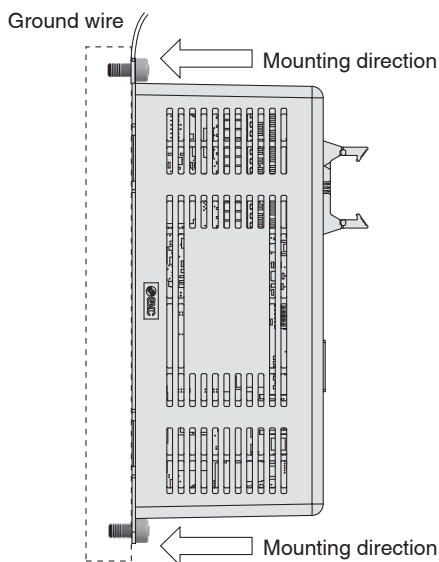

b) DIN rail mounting (JXC□H8□) (Installation with the DIN rail)

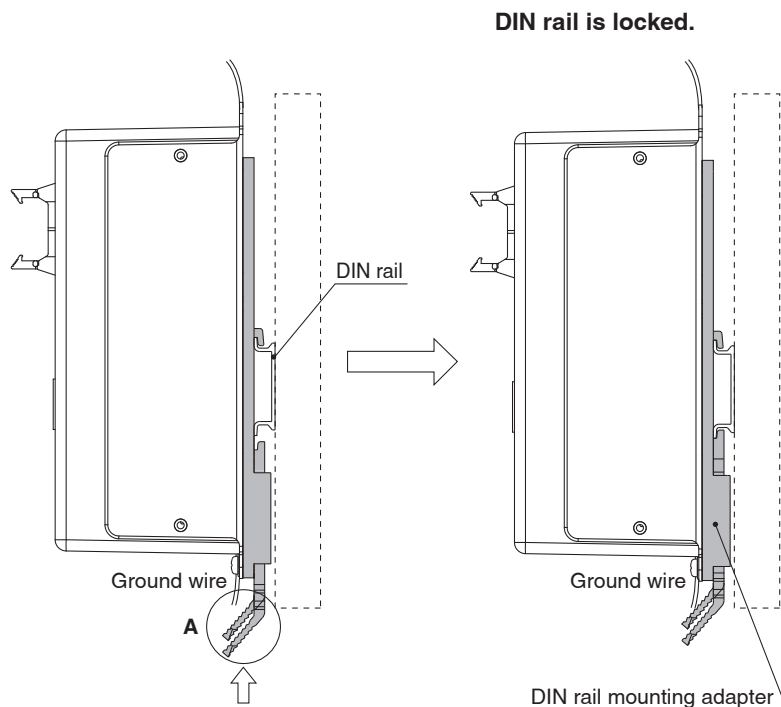

Hook the controller on the DIN rail and press the lever of section **A** in the arrow direction to lock it.

* When size 25 or more of the LE series are used, the space between the controllers should be 10 mm or more.

DIN rail AXT100-DR-□

* For □, enter a number from the No. line in the table below.
Refer to the dimension drawings on page 45 for the mounting dimensions.

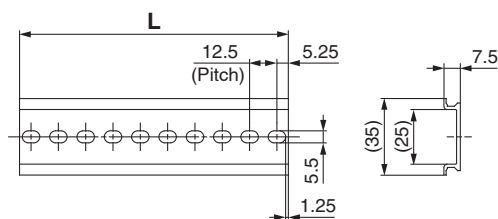

L Dimensions [mm]

| | | | | | | | | | | | | | | | | | | | | |
|----------|-----|-------|-----|-------|-----|-------|-----|-------|-----|-------|-----|-------|-----|-------|-----|-------|-----|-------|-----|-------|
| No. | 1 | 2 | 3 | 4 | 5 | 6 | 7 | 8 | 9 | 10 | 11 | 12 | 13 | 14 | 15 | 16 | 17 | 18 | 19 | 20 |
| L | 23 | 35.5 | 48 | 60.5 | 73 | 85.5 | 98 | 110.5 | 123 | 135.5 | 148 | 160.5 | 173 | 185.5 | 198 | 210.5 | 223 | 235.5 | 248 | 260.5 |
| No. | 21 | 22 | 23 | 24 | 25 | 26 | 27 | 28 | 29 | 30 | 31 | 32 | 33 | 34 | 35 | 36 | 37 | 38 | 39 | 40 |
| L | 273 | 285.5 | 298 | 310.5 | 323 | 335.5 | 348 | 360.5 | 373 | 385.5 | 398 | 410.5 | 423 | 435.5 | 448 | 460.5 | 473 | 485.5 | 498 | 510.5 |

DIN rail mounting adapter LEC-3-D0 (with 2 mounting screws)

This should be used when the DIN rail mounting adapter is mounted onto a screw mounting type controller afterward.

JXC5H/6H Series

Dimensions

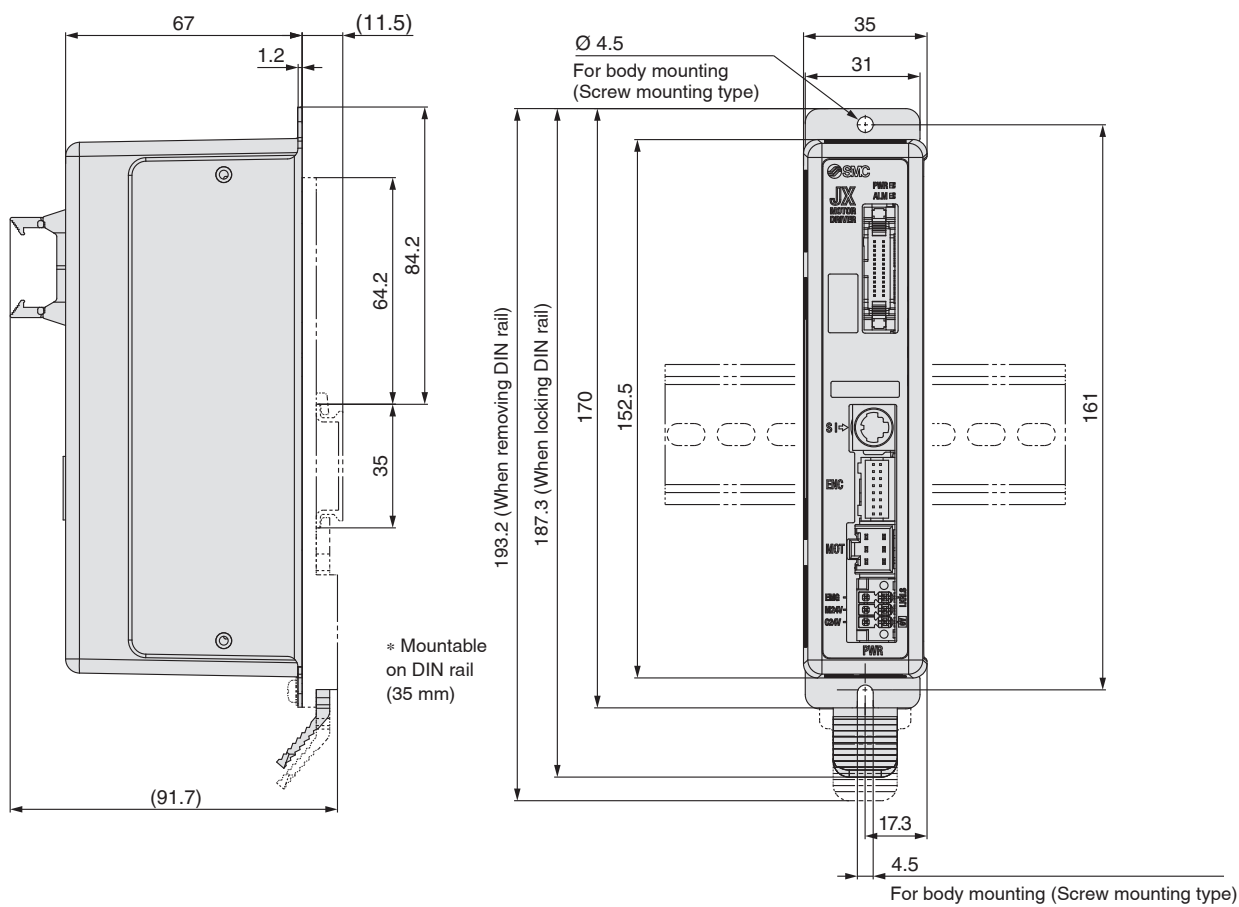

Wiring Example 1

Parallel I/O Connector

- * When you connect a PLC to the parallel I/O connector, use the I/O cable (LEC-CN5-□).
- * The wiring changes depending on the type of parallel I/O (NPN or PNP).

Wiring diagram JXC5H□□ (NPN)

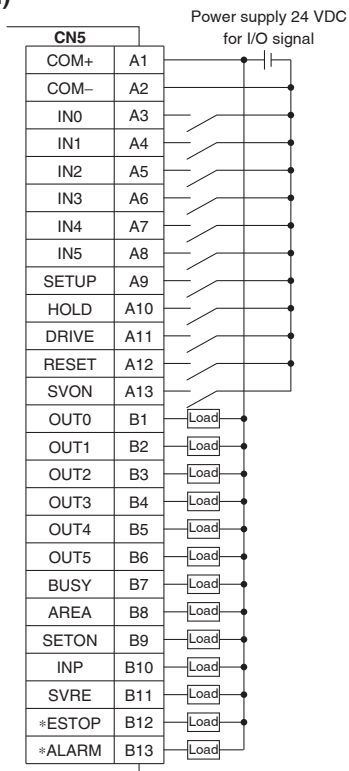

Input Signal

| Name | Details |
|------------|---|
| COM+ | Connects the power supply 24 V for input/output signal |
| COM- | Connects the power supply 0 V for input/output signal |
| IN0 to IN5 | Step data specified bit no. (Input is instructed by combining IN0 to 5.) |
| SETUP | Instruction to return to origin |
| HOLD | Temporarily stops operation |
| DRIVE | Instruction to drive |
| RESET | Resets alarm and interrupts operation |
| SVON | Servo ON instruction |

JXC6H□□ (PNP)

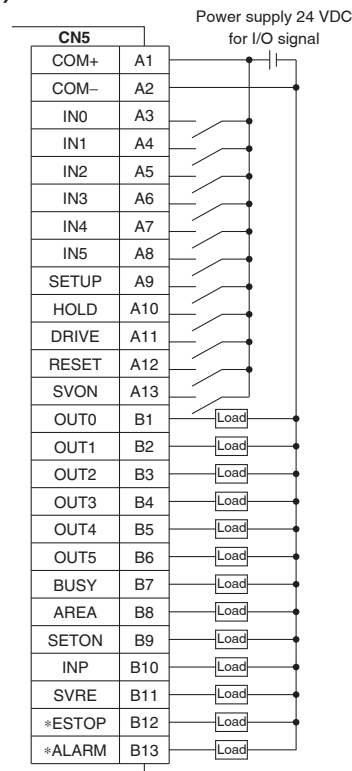

Output Signal

| Name | Details |
|----------------------|---|
| OUT0 to OUT5 | Outputs the step data no. during operation |
| BUSY | Outputs when the actuator is moving |
| AREA | Outputs within the step data area output setting range |
| SETON | Outputs when returning to origin |
| INP | Outputs when target position or target force is reached (Turns on when the positioning or pushing is completed.) |
| SVRE | Outputs when servo is on |
| *ESTOP* ¹ | OFF when EMG stop is instructed |
| *ALARM* ¹ | OFF when alarm is generated |

*¹ Signal of negative-logic circuit (N.C.)

Step Data Setting

1. Step data setting for positioning

In this setting, the actuator moves toward and stops at the target position.

The following diagram shows the setting items and operation.

The setting items and set values for this operation are stated below.

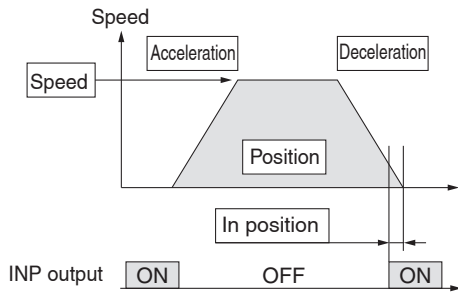

- ◎ : Need to be set.
- : Need to be adjusted as required.
- : Setting is not required.

Step Data (Positioning)

| Necessity | Item | Details |
|-----------|----------------|--|
| ◎ | Movement MOD | When the absolute position is required, set Absolute. When the relative position is required, set Relative. |
| ◎ | Speed | Transfer speed to the target position |
| ◎ | Position | Target position |
| ○ | Acceleration | Parameter which defines how rapidly the actuator reaches the speed set. The higher the set value, the faster it reaches the speed set. |
| ○ | Deceleration | Parameter which defines how rapidly the actuator comes to stop. The higher the set value, the quicker it stops. |
| ◎ | Pushing force | Set 0. (If values 1 to 100 are set, the operation will be changed to the pushing operation.) |
| — | Trigger LV | Setting is not required. |
| — | Pushing speed | Setting is not required. |
| ○ | Moving force | Max. torque during the positioning operation (No specific change is required.) |
| ○ | Area 1, Area 2 | Condition that turns on the AREA output signal. |
| ○ | In position | Condition that turns on the INP output signal. When the actuator enters the range of [in position], the INP output signal turns on. (It is unnecessary to change this from the initial value.) When it is necessary to output the arrival signal before the operation is completed, make the value larger. |

2. Step data setting for pushing

The actuator moves toward the pushing start position, and when it reaches that position, it starts pushing with the set force or less.

The following diagram shows the setting items and operation. The setting items and set values for this operation are stated below.

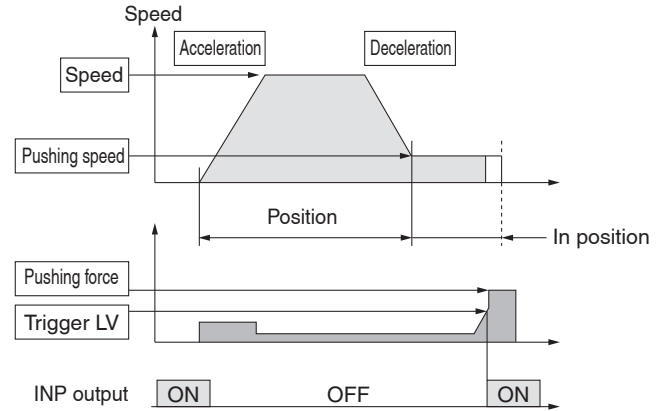

- ◎ : Need to be set.
- : Need to be adjusted as required.

Step Data (Pushing)

| Necessity | Item | Details |
|-----------|----------------|--|
| ◎ | Movement MOD | When the absolute position is required, set Absolute. When the relative position is required, set Relative. |
| ◎ | Speed | Transfer speed to the pushing start position |
| ◎ | Position | Pushing start position |
| ○ | Acceleration | Parameter which defines how rapidly the actuator reaches the speed set. The higher the set value, the faster it reaches the speed set. |
| ○ | Deceleration | Parameter which defines how rapidly the actuator comes to stop. The higher the set value, the quicker it stops. |
| ◎ | Pushing force | Pushing force ratio is defined. The setting range differs depending on the electric actuator type. Refer to the operation manual for the electric actuator. |
| ◎ | Trigger LV | Condition that turns on the INP output signal. The INP output signal turns on when the generated force exceeds the value. Trigger level should be the pushing force or less. |
| ○ | Pushing speed | Pushing speed during pushing. When the speed is set fast, the electric actuator and workpieces might be damaged due to the impact when they hit the end, so this set value should be smaller. Refer to the operation manual for the electric actuator. |
| ○ | Moving force | Max. torque during the positioning operation (No specific change is required.) |
| ○ | Area 1, Area 2 | Condition that turns on the AREA output signal. |
| ◎ | In position | Transfer distance during pushing. If the transferred distance exceeds the setting, it stops even if it is not pushing. If the transfer distance is exceeded, the INP output signal will not turn on. |

Signal Timing

Return to Origin

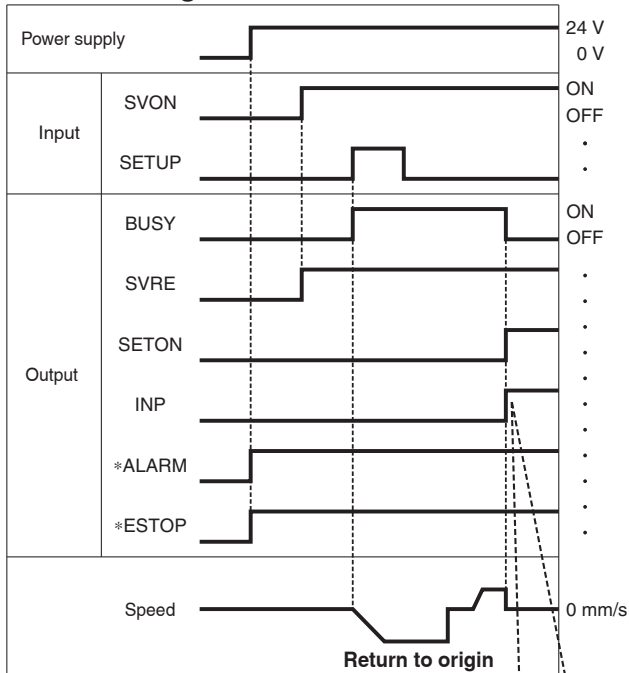

* *ALARM and *ESTOP are expressed as negative-logic circuits.

Positioning Operation

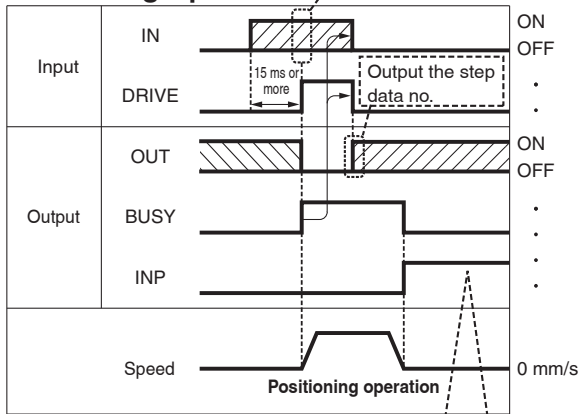

* "OUT" is output when "DRIVE" is changed from ON to OFF. Refer to the operation manual for details on the controller for the LEM series. (When power supply is applied, "DRIVE" or "RESET" is turned ON or *ESTOP is turned OFF, all of the "OUT" outputs are OFF.)

Pushing Operation

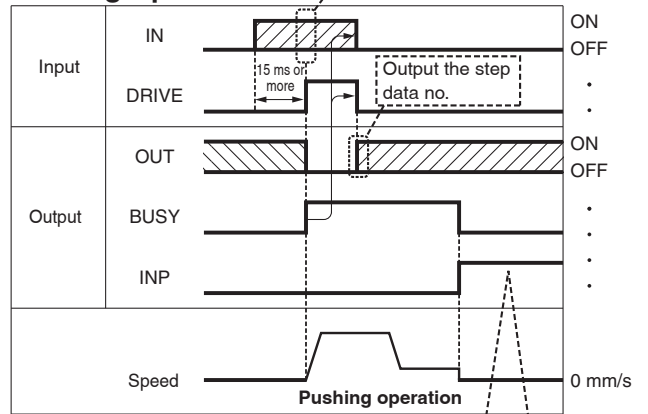

Reset

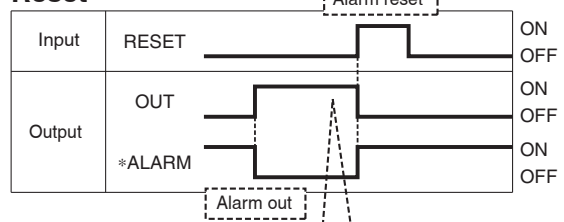

* *ALARM is expressed as a negative-logic circuit.

HOLD

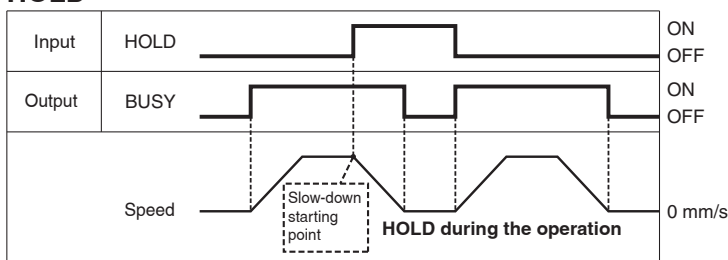

* When the actuator is within the "In position" range in the pushing operation, it does not stop even if HOLD signal is input.

JXC5H/6H Series

Options

■ Communication cable for controller setting

① Communication cable JXC-W2A-C

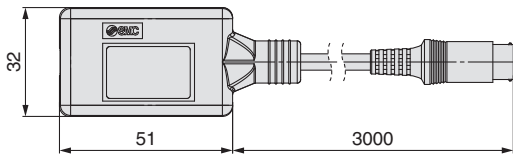

* It can be connected to the controller directly.

② USB cable LEC-W2-U

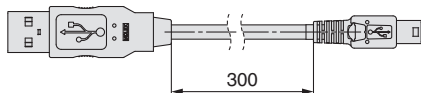

③ Controller setting kit JXC-W2A

A set which includes a communication cable (JXC-W2A-C) and a USB cable (LEC-W2-U)

<Controller setting software/USB driver>

- Controller setting software
 - USB driver (For JXC-W2A-C)
- Download from SMC's website:
<https://www.smc.eu>

Hardware Requirements

| | |
|-------------------------|------------------------------------|
| OS | Windows®7, Windows®8.1, Windows®10 |
| Communication interface | USB 1.1 or USB 2.0 ports |
| Display | 1024 x 768 or more |

* Windows®7, Windows®8.1, and Windows®10 are registered trademarks of Microsoft Corporation in the United States.

■ Conversion cable P5062-5 (Cable length: 300 mm)

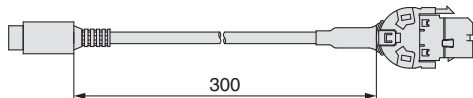

* To connect the teaching box (LEC-T 1 - 3 □□□) or controller setting kit (LEC-W2□) to the controller, a conversion cable is required.

■ I/O cable

LEC-CN5-1

Cable length (L) [m]

| | |
|---|-----|
| 1 | 1.5 |
| 3 | 3 |
| 5 | 5 |

* Conductor size: AWG28

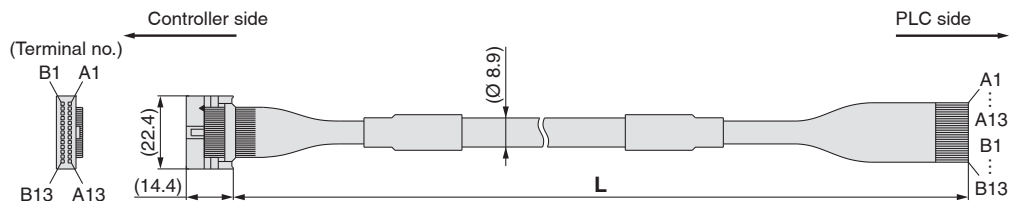

| Connector pin no. | Insulation colour | Dot mark | Dot colour |
|-------------------|-------------------|----------|------------|
| A1 | Light brown | ■ | Black |
| A2 | Light brown | ■ | Red |
| A3 | Yellow | ■ | Black |
| A4 | Yellow | ■ | Red |
| A5 | Light green | ■ | Black |
| A6 | Light green | ■ | Red |
| A7 | Grey | ■ | Black |
| A8 | Grey | ■ | Red |
| A9 | White | ■ | Black |
| A10 | White | ■ | Red |
| A11 | Light brown | ■ ■ | Black |
| A12 | Light brown | ■ ■ | Red |
| A13 | Yellow | ■ ■ | Black |

| Connector pin no. | Insulation colour | Dot mark | Dot colour |
|-------------------|-------------------|----------|------------|
| B1 | Yellow | ■ ■ | Red |
| B2 | Light green | ■ ■ | Black |
| B3 | Light green | ■ ■ | Red |
| B4 | Grey | ■ ■ | Black |
| B5 | Grey | ■ ■ | Red |
| B6 | White | ■ ■ | Black |
| B7 | White | ■ ■ | Red |
| B8 | Light brown | ■ ■ ■ | Black |
| B9 | Light brown | ■ ■ ■ | Red |
| B10 | Yellow | ■ ■ ■ | Black |
| B11 | Yellow | ■ ■ ■ | Red |
| B12 | Light green | ■ ■ ■ | Black |
| B13 | Light green | ■ ■ ■ | Red |
| — | | | Shield |

Weight

| Product no. | Weight [g] |
|-------------|------------|
| LEC-CN5-1 | 170 |
| LEC-CN5-3 | 320 |
| LEC-CN5-5 | 520 |

■ Power supply plug JXC-CPW

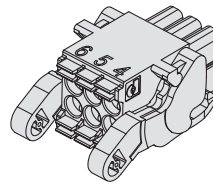

* The power supply plug is an accessory.
 <Applicable cable size> AWG20 (0.5 mm²), cover diameter 2.0 mm or less



- ① C24V
- ② M24V
- ③ EMG
- ④ 0V
- ⑤ N.C.
- ⑥ LK RLS

Power supply plug

| Terminal name | Function | Details |
|---------------|--------------------------|---|
| 0V | Common supply (-) | The M24V terminal, C24V terminal, EMG terminal, and LK RLS terminal are common (-). |
| M24V | Motor power supply (+) | Motor power supply (+) of the controller |
| C24V | Control power supply (+) | Control power supply (+) of the controller |
| EMG | Stop (+) | Connection terminal of the external stop circuit |
| LK RLS | Lock release (+) | Connection terminal of the lock release switch |

■ Teaching box

LEC-T1-3EG□

Teaching box

Cable length [m]
 3 3

Initial language

| | |
|---|----------|
| J | Japanese |
| E | English |

Enable switch (Option)



Enable switch

| | |
|---|-----------------------------|
| — | None |
| S | Equipped with enable switch |

* Interlock switch for jog and test function

Stop switch

| | |
|---|---------------------------|
| G | Equipped with stop switch |
|---|---------------------------|

Specifications

| Item | Description |
|----------------------------------|-------------------------------------|
| Switch | Stop switch, Enable switch (Option) |
| Cable length [m] | 3 |
| Enclosure | IP64 (Except connector) |
| Operating temperature range [°C] | 5 to 50 |
| Operating humidity range [%RH] | 90 or less (No condensation) |
| Weight [g] | 350 (Except cable) |

High Performance Step Motor Controller

JXCEH/9H/PH Series



How to Order

⚠ Caution

[CE/UKCA-compliant products]

- ① EMC compliance was tested by combining the electric actuator LE series and the JXCEH/PH series.
The EMC depends on the configuration of the customer's control panel and the relationship with other electrical equipment and wiring. Therefore, compliance with the EMC directive cannot be certified for SMC components incorporated into the customer's equipment under actual operating conditions. As a result, it is necessary for the customer to verify compliance with the EMC directive for the machinery and equipment as a whole.
- ② For the JXCEH/PH series (step motor controller), EMC compliance was tested by installing a noise filter set (LEC-NFA). Refer to page 54 for the noise filter set. Refer to the JXCEH/PH Operation Manual for installation.

JXC **P** **H** **7** - []

Communication protocol

| | |
|----------|--------------|
| E | EtherCAT |
| 9 | EtherNet/IP™ |
| P | PROFINET |

High performance

Mounting

| | |
|-------------|----------------|
| 7 | Screw mounting |
| 8 *1 | DIN rail |

*1 The DIN rail is not included. It must be ordered separately. (Refer to page 54.)

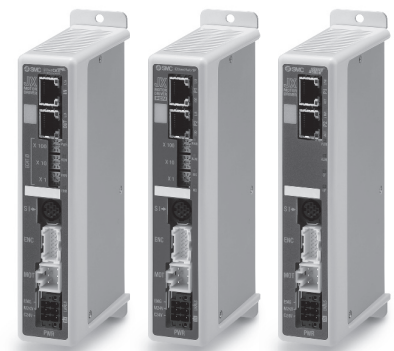

EtherCAT EtherNet/IP PROFINET

Actuator part number

Without cable specifications and actuator options
Example: Enter "LEFS16GB-100"
for the LEFS16GB-100B-S1□□.

BC Blank controller*1

*1 Requires dedicated software (JXC-BCW)

The controller is sold as single unit after the compatible actuator is set.

Confirm that the combination of the controller and actuator is correct.

- ① Check the actuator label for the model number. This number should match that of the controller.

LEFS16GB-400

①

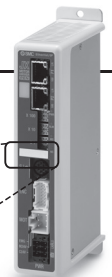

* Refer to the operation manual for using the products. Please download it via our website: <https://www.smc.eu>

Precautions for blank controllers (JXC□H□-BC)

A blank controller is a controller to which the customer can write the data of the actuator it is to be combined and used with. Use the dedicated software (JXC-BCW) for data writing.

- Please download the dedicated software (JXC-BCW) via our website.
- Order the communication cable for controller setting (JXC-W2A-C) and USB cable (LEC-W2-U) separately to use this software.

SMC website: <https://www.smc.eu>

JXCEH/9H/PH Series

Specifications

| Model | | JXCEH | JXC9H | JXCPH | |
|----------------------------------|----------------------|---|---|--|----------------------------|
| Network | | EtherCAT | EtherNet/IP™ | PROFINET | |
| Compatible motor | | Step motor (Servo/24 VDC) | | | |
| Power supply | | Power voltage: 24 VDC ±10 % | | | |
| Current consumption (Controller) | | 200 mA or less | 200 mA or less | 200 mA or less | |
| Compatible encoder | | Battery-less absolute encoder | | | |
| Communication specifications | Applicable system | Protocol | EtherCAT*2 | EtherNet/IP™*2 | PROFINET*2 |
| | | Version*1 | Conformance Test Record V.1.2.6 | Volume 1 (Edition 3.14) Volume 2 (Edition 1.15) | Specification Version 2.32 |
| | Communication speed | 100 Mbps*2 | 10/100 Mbps*2 (Automatic negotiation) | 100 Mbps*2 | |
| | Configuration file*3 | ESI file | EDS file | GSDML file | |
| | I/O occupation area | Input 20 bytes Output 36 bytes | Input 36 bytes Output 36 bytes | Input 36 bytes Output 36 bytes | |
| | Terminating resistor | Not included | | | |
| Memory | | EEPROM | | | |
| LED indicator | | PWR, RUN, ALM, ERR | PWR, ALM, MS, NS | PWR, ALM, SF, BF | |
| Cable length [m] | | Actuator cable: 20 or less | | | |
| Cooling system | | Natural air cooling | | | |
| Operating temperature range [°C] | | 0 to 40 (No freezing)*4 | | | |
| Operating humidity range [%RH] | | 90 or less (No condensation) | | | |
| Insulation resistance [MΩ] | | Between all external terminals and the case: 50 (500 VDC) | | | |
| Weight [g] | | 260 (Screw mounting) 280 (DIN rail mounting) | 250 (Screw mounting) 270 (DIN rail mounting) | 260 (Screw mounting) 280 (DIN rail mounting) | |

*1 Please note that versions are subject to change.

*2 Use a shielded communication cable with CAT5 or higher for the PROFINET, EtherNet/IP™, and EtherCAT.

*3 The files can be downloaded from the SMC website.

*4 The operating temperature range for both controller version 1 products and controller version 2 products is 0 to 40 °C. Refer to the **Web Catalogue** for details on identifying controller version symbols

■ Trademark

EtherNet/IP® is a registered trademark of ODVA, Inc.

EtherCAT® is registered trademark and patented technology, licensed by Beckhoff Automation GmbH, Germany.

Example of Operation Command

In addition to the step data input of 64 points maximum in each communication protocol, the changing of each parameter can be performed in real time via numerical data defined operation.

* Numerical values other than "Moving force," "Area 1," and "Area 2" can be used to perform operation under numerical instructions from JXCL1.

<Application example> Movement between 2 points

| No. | Movement mode | Speed | Position | Acceleration | Deceleration | Pushing force | Trigger LV | Pushing speed | Moving force | Area 1 | Area 2 | In position |
|-----|---------------|-------|----------|--------------|--------------|---------------|------------|---------------|--------------|--------|--------|-------------|
| 0 | 1: Absolute | 100 | 10 | 3000 | 3000 | 0 | 0 | 0 | 100 | 0 | 0 | 0.50 |
| 1 | 1: Absolute | 100 | 100 | 3000 | 3000 | 0 | 0 | 0 | 100 | 0 | 0 | 0.50 |

<Step no. defined operation>

Sequence 1: Servo ON instruction

Sequence 2: Instruction to return to origin

Sequence 3: Specify step data No. 0 to input the DRIVE signal.

Sequence 4: Specify step data No. 1 after the DRIVE signal has been temporarily turned OFF to input the DRIVE signal.

<Numerical data defined operation>

Sequence 1: Servo ON instruction

Sequence 2: Instruction to return to origin

Sequence 3: Specify step data No. 0 and turn ON the input instruction flag (position). Input 10 in the target position. Subsequently the start flag turns ON.

Sequence 4: Turn ON step data No. 0 and the input instruction flag (position) to change the target position to 100 while the start flag is ON.

The same operation can be performed with any operation command.

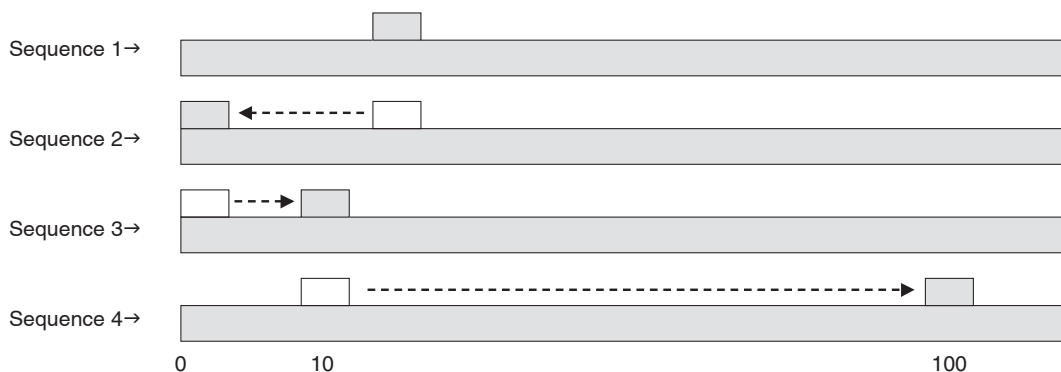

Dimensions

JXCEH

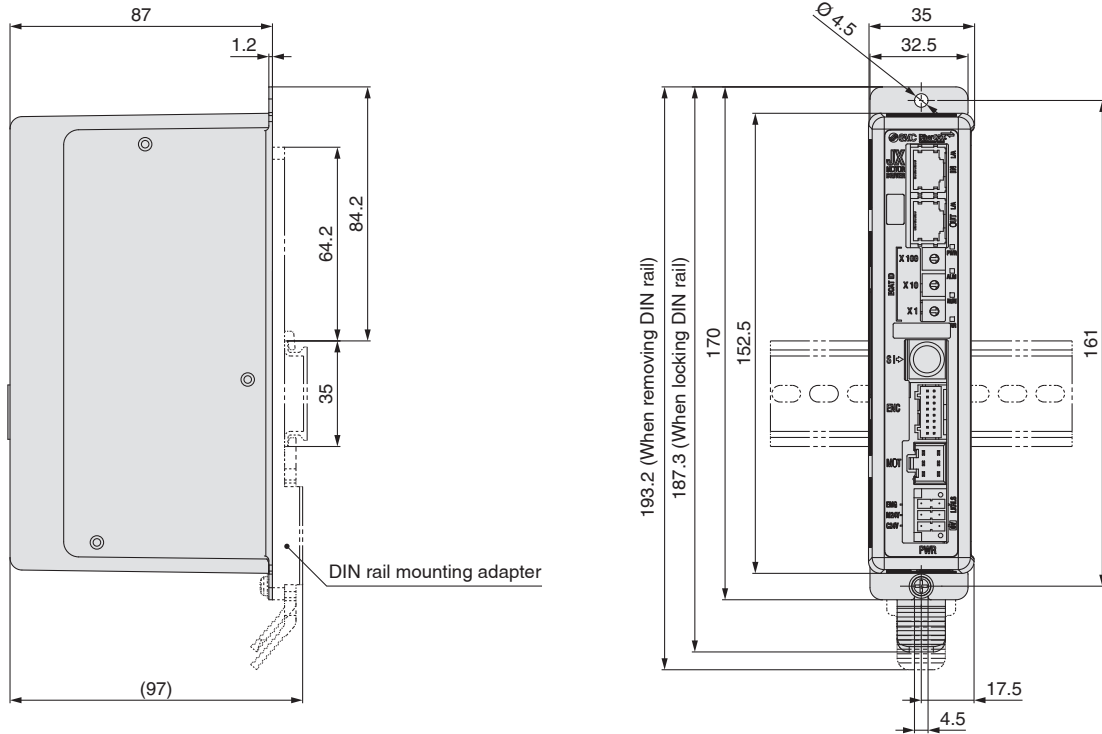

JXC9H

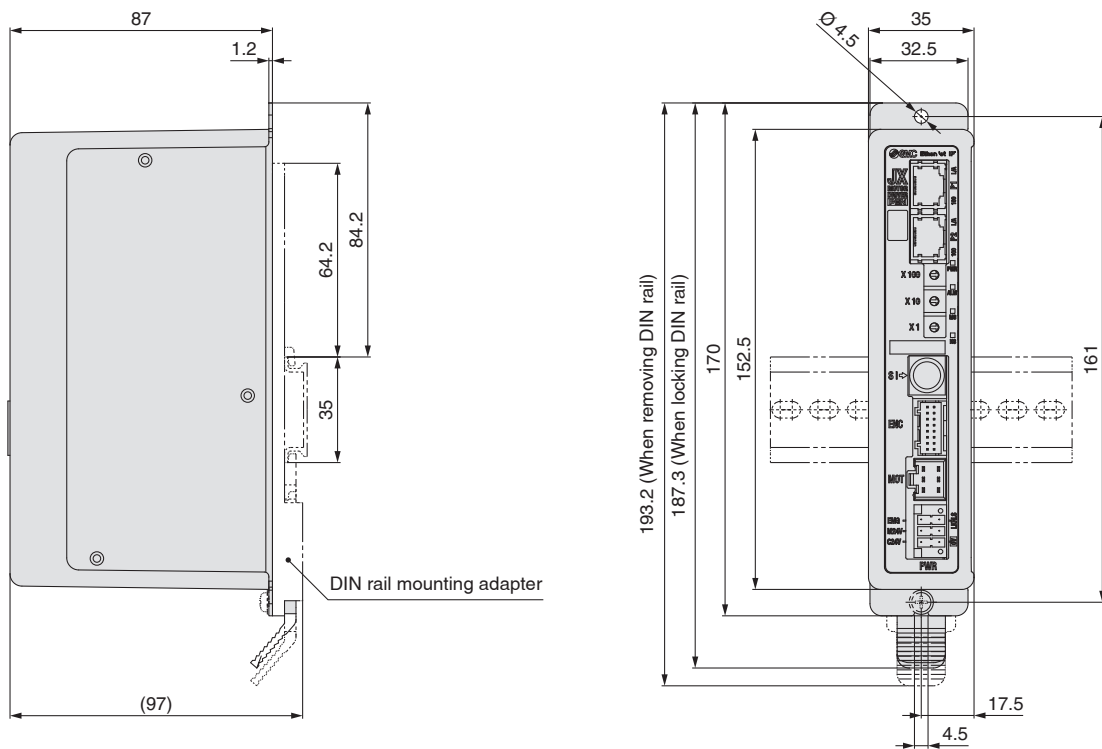

JXCEH/9H/PH Series

Dimensions

JXCPH

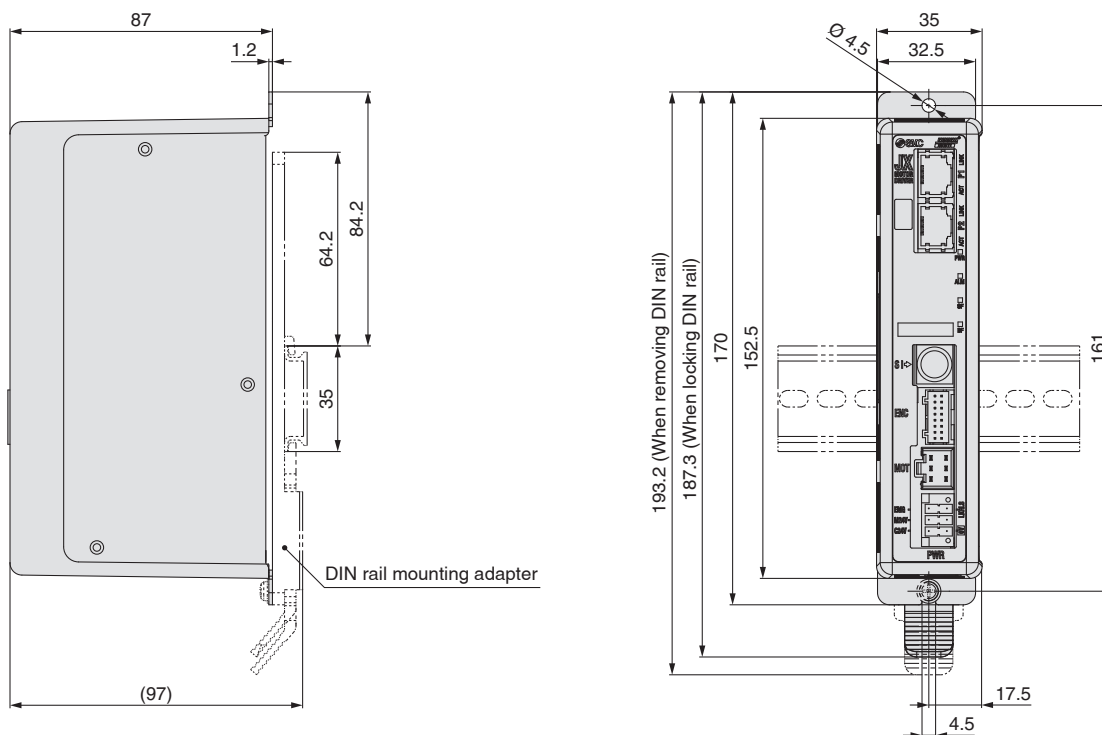

DIN rail

AXT100-DR-□

* For □, enter a number from the No. line in the table below.
Refer to the dimension drawings on pages 52 and 53 for the mounting dimensions.

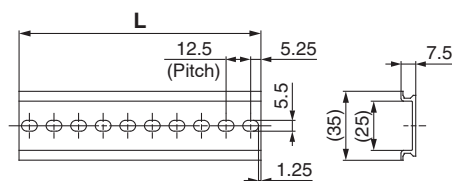

L Dimensions [mm]

| | | | | | | | | | | | | | | | | | | | | |
|-----|-----|-------|-----|-------|-----|-------|-----|-------|-----|-------|-----|-------|-----|-------|-----|-------|-----|-------|-----|-------|
| No. | 1 | 2 | 3 | 4 | 5 | 6 | 7 | 8 | 9 | 10 | 11 | 12 | 13 | 14 | 15 | 16 | 17 | 18 | 19 | 20 |
| L | 23 | 35.5 | 48 | 60.5 | 73 | 85.5 | 98 | 110.5 | 123 | 135.5 | 148 | 160.5 | 173 | 185.5 | 198 | 210.5 | 223 | 235.5 | 248 | 260.5 |
| No. | 21 | 22 | 23 | 24 | 25 | 26 | 27 | 28 | 29 | 30 | 31 | 32 | 33 | 34 | 35 | 36 | 37 | 38 | 39 | 40 |
| L | 273 | 285.5 | 298 | 310.5 | 323 | 335.5 | 348 | 360.5 | 373 | 385.5 | 398 | 410.5 | 423 | 435.5 | 448 | 460.5 | 473 | 485.5 | 498 | 510.5 |

DIN rail mounting adapter

LEC-3-D0 (with 2 mounting screws)

This should be used when the DIN rail mounting adapter is mounted onto a screw mounting type controller afterward.

Options

■ Communication cable for controller setting

① Communication cable JXC-W2A-C

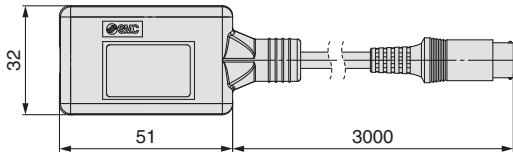

* It can be connected to the controller directly.

② USB cable LEC-W2-U

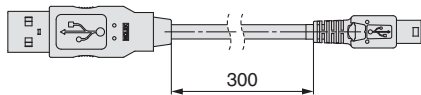

③ Controller setting kit JXC-W2A

A set which includes a communication cable (JXC-W2A-C) and a USB cable (LEC-W2-U)

<Controller setting software/USB driver>

- Controller setting software
- USB driver (For JXC-W2A-C)

Download from SMC's website: <https://www.smc.eu>

Hardware Requirements

| | |
|-------------------------|------------------------------------|
| OS | Windows®7, Windows®8.1, Windows®10 |
| Communication interface | USB 1.1 or USB 2.0 ports |
| Display | 1024 x 768 or more |

* Windows®7, Windows®8.1 and Windows®10 are registered trademarks of Microsoft Corporation in the United States.

■ DIN rail mounting adapter LEC-3-D0

* With 2 mounting screws

This should be used when the DIN rail mounting adapter is mounted onto a screw mounting type controller afterward.

■ DIN rail AXT100-DR-□

* For □, enter a number from the No. line in the table on pages 44 and 53. Refer to the dimension drawings on pages 45, 52, and 53 for the mounting dimensions.

■ Teaching box

LEC-T1-3EG

Teaching box

| | |
|------------------|---|
| Cable length [m] | 3 |
|------------------|---|

Initial language

| | |
|---|----------|
| J | Japanese |
| E | English |

Enable switch (Option)

● Enable switch

| | |
|---|-----------------------------|
| — | None |
| S | Equipped with enable switch |

* Interlock switch for jog and test function

● Stop switch

| | |
|---|---------------------------|
| G | Equipped with stop switch |
|---|---------------------------|

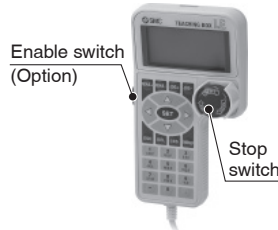

Specifications

| Item | Description |
|----------------------------------|-------------------------------------|
| Switch | Stop switch, Enable switch (Option) |
| Cable length [m] | 3 |
| Enclosure | IP64 (Except connector) |
| Operating temperature range [°C] | 5 to 50 |
| Operating humidity range [%RH] | 90 or less (No condensation) |
| Weight [g] | 350 (Except cable) |

■ Power supply plug JXC-CPW

* The power supply plug is an accessory.

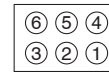
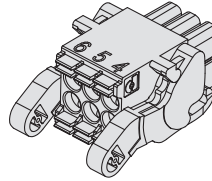

- | | |
|--------|----------|
| ① C24V | ④ 0V |
| ② M24V | ⑤ N.C. |
| ③ EMG | ⑥ LK RLS |

Power supply plug

| Terminal name | Function | Details |
|---------------|--------------------------|---|
| 0V | Common supply (-) | The M24V terminal, C24V terminal, EMG terminal, and LK RLS terminal are common (-). |
| M24V | Motor power supply (+) | Motor power supply (+) of the controller |
| C24V | Control power supply (+) | Control power supply (+) of the controller |
| EMG | Stop (+) | Connection terminal of the external stop circuit |
| LK RLS | Lock release (+) | Connection terminal of the lock release switch |

■ Conversion cable P5062-5 (Cable length: 300 mm)

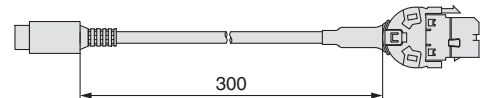

* To connect the teaching box (LEC-T1-3□G□) or controller setting kit (LEC-W2) to the controller, a conversion cable is required.

■ Noise filter set

LEC-NFA

Contents of the set: 2 noise filters

(Manufactured by WURTH ELEKTRONIK: 74271222)

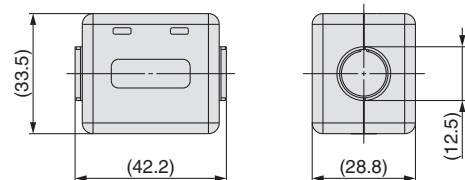

* Refer to the JXCEH/PH series Operation Manual for installation.

JXC5H/6H Series JXCEH/9H/PH Series Actuator Cable (Option)

[Robotic cable for battery-less absolute (Step motor 24 VDC)]

LE-CE-1

Cable length (L) [m]

| | |
|---|------|
| 1 | 1.5 |
| 3 | 3 |
| 5 | 5 |
| 8 | 8*1 |
| A | 10*1 |
| B | 15*1 |
| C | 20*1 |

*1 Produced upon receipt of order

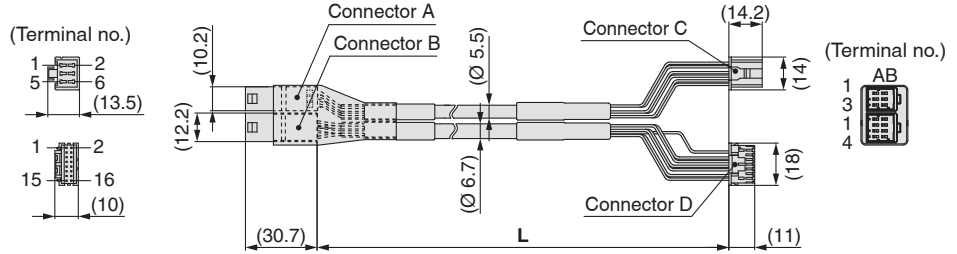

Weight

| Product no. | Weight [g] | Note |
|-------------|------------|---------------|
| LE-CE-1 | 190 | Robotic cable |
| LE-CE-3 | 360 | |
| LE-CE-5 | 570 | |
| LE-CE-8 | 900 | |
| LE-CE-A | 1120 | |
| LE-CE-B | 1680 | |
| LE-CE-C | 2210 | |

| Signal | Connector A terminal no. | Cable colour | Connector C terminal no. |
|-----------|--------------------------|--------------|--------------------------|
| A | B-1 | Brown | 2 |
| \bar{A} | A-1 | Red | 1 |
| B | B-2 | Orange | 6 |
| \bar{B} | A-2 | Yellow | 5 |
| COM-A/COM | B-3 | Green | 3 |
| COM-B/— | A-3 | Blue | 4 |

| Signal | Connector B terminal no. | Cable colour | Connector D terminal no. |
|-----------|--------------------------|--------------|--------------------------|
| Vcc | B-1 | Brown | 12 |
| GND | A-1 | Black | 13 |
| \bar{A} | B-2 | Red | 7 |
| A | A-2 | Black | 6 |
| \bar{B} | B-3 | Orange | 9 |
| B | A-3 | Black | 8 |
| SD+ (RX) | B-4 | Yellow | 11 |
| SD- (TX) | A-4 | Black | 10 |
| | | Black | 3 |

[Robotic cable with lock for battery-less absolute (Step motor 24 VDC)]

LE-CE-1-B

Cable length (L) [m]

| | |
|---|------|
| 1 | 1.5 |
| 3 | 3 |
| 5 | 5 |
| 8 | 8*1 |
| A | 10*1 |
| B | 15*1 |
| C | 20*1 |

*1 Produced upon receipt of order

With lock and sensor

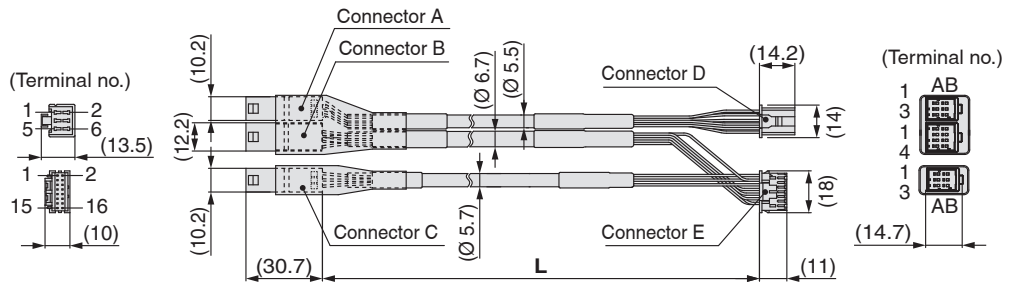

Weight

| Product no. | Weight [g] | Note |
|-------------|------------|---------------|
| LE-CE-1-B | 240 | Robotic cable |
| LE-CE-3-B | 460 | |
| LE-CE-5-B | 740 | |
| LE-CE-8-B | 1170 | |
| LE-CE-A-B | 1460 | |
| LE-CE-B-B | 2120 | |
| LE-CE-C-B | 2890 | |

| Signal | Connector A terminal no. | Cable colour | Connector D terminal no. |
|-----------|--------------------------|--------------|--------------------------|
| A | B-1 | Brown | 2 |
| \bar{A} | A-1 | Red | 1 |
| B | B-2 | Orange | 6 |
| \bar{B} | A-2 | Yellow | 5 |
| COM-A/COM | B-3 | Green | 3 |
| COM-B/— | A-3 | Blue | 4 |

| Signal | Connector B terminal no. | Cable colour | Connector E terminal no. |
|-----------|--------------------------|--------------|--------------------------|
| Vcc | B-1 | Brown | 12 |
| GND | A-1 | Black | 13 |
| \bar{A} | B-2 | Red | 7 |
| A | A-2 | Black | 6 |
| \bar{B} | B-3 | Orange | 9 |
| B | A-3 | Black | 8 |
| SD+ (RX) | B-4 | Yellow | 11 |
| SD- (TX) | A-4 | Black | 10 |
| | | Black | 3 |

| Signal | Connector C terminal no. | Cable colour | Terminal no. |
|------------|--------------------------|--------------|--------------|
| Lock (+) | B-1 | Red | 4 |
| Lock (-) | A-1 | Black | 5 |
| Sensor (+) | B-3 | Brown | 1 |
| Sensor (-) | A-3 | Blue | 2 |



JXC□1/JXC□F/JXC□H Series Precautions Relating to Differences in Controller Versions

As the controller version of the JXC series differs, the internal parameters are not compatible.

- If using the JXC□1□-BC, please use the latest version of the JXC-BCW (parameter writing tool).
- There are currently 3 versions available: version 1 products (V1.□ or S1.□), version 2 products (V2.□ or S2.□), and version 3 products (V3.□ or S3.□). Keep in mind that in order to write a backup file (.bcp) to another controller with the JXC-BCW, it needs to be the same version as the controller that created the file. (For example, a backup file created by a version 1 product can only be written to another version 1 product, and so on.)

Identifying Version Symbols



JXC□□ Series Version V3.□ or S3.□ Products

XR V3.0

Applicable models
JXC91 Series

XR S3.0 T1.0

Applicable models
JXC51 Series
JXC61 Series
JXCE□ Series
JXCP1 Series
JXCD1 Series
JXCL□ Series
JXCM1 Series

JXC□□ Series Version V2.□ or S2.□ Products

WP V2.1

Applicable models
JXC91 Series

WP S2.2 T1.1

Applicable models
JXCE□ Series
JXCP1 Series
JXCD1 Series
JXCL□ Series

JXC□□ Series Version V1.□ or S1.□ Products

XR V1.0

Applicable models
JXC91 Series

XR S1.0 T1.0

Applicable models
JXCE□ Series
JXCP□ Series
JXCD1 Series
JXCL□ Series
JXC5H Series
JXC6H Series

Blank Controller Versions and Applicable Battery-less Absolute Type Electric Actuator Sizes

- The applicable battery-less absolute type electric actuator size range differs depending on the controller version.
Be sure to confirm the controller version before using a blank controller.

Blank Controller Versions/Applicable Electric Actuator Sizes (JXC□H Series)

| Blank controller | | Applicable electric actuator size | | | | |
|--|-----------------------|-----------------------------------|------------|------------|------------|-----------|
| Series | Controller version | LEFS□G | LEKF□G | LEY□G | LEG | LESYH□G |
| JXC9H series JXCEH series JXCPH series | All versions | 16, 25, 32, 40 | 25, 32, 40 | 16, 25, 40 | 25, 32, 40 | 8, 16, 25 |
| | Version 1.0 | 25, 32, 40 | | 25, 40 | | 16, 25 |
| JXC5H/6H series | Version 1.1 or higher | 16, 25, 32, 40 | | 16, 25, 40 | | 8, 16, 25 |



Battery-less Absolute Encoder Type Specific Product Precautions

Be sure to read this before handling the products. Refer to the back cover for safety instructions. For electric actuator precautions, refer to the “Handling Precautions for SMC Products” and the “Operation Manual” on the SMC website: <https://www.smc.eu>

Handling

⚠ Caution

1. Absolute encoder ID mismatch error at the first connection

In the following cases, an “ID mismatch error” alarm occurs after the power is turned ON. Perform a return to origin operation after resetting the alarm before use.

- When an electric actuator is connected and the power is turned ON for the first time after purchase*1
- When the actuator or motor is replaced
- When the controller is replaced

*1 If you have purchased an electric actuator and controller with the set part number, the pairing may have already been completed and the alarm may not be generated.

“ID mismatch error”

Operation is enabled by matching the encoder ID on the electric actuator side with the ID registered in the controller. This alarm occurs when the encoder ID is different from the registered contents of the controller. By resetting this alarm, the encoder ID is registered (paired) to the controller again.

| When a controller is changed after pairing is completed | | | | |
|---|--|-------|------------------|-------|
| | Encoder ID no. (* Numbers below are examples.) | | | |
| Actuator | 17623 | 17623 | 17623 | 17623 |
| Controller | 17623 | 17699 | 17699 | 17623 |
| ID mismatch error occurred? | No | Yes | Error reset ⇒ No | |

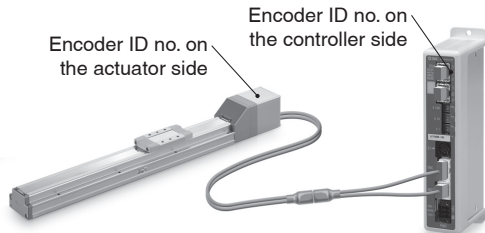

The ID number is automatically checked when the control power supply is turned ON. An error is output if the ID number does not match.

2. In environments where strong magnetic fields are present, use may be limited.

A magnetic sensor is used in the encoder. Therefore, if the actuator motor is used in an environment where strong magnetic fields are present, malfunction or failure may occur. Do not expose the actuator motor to magnetic fields with a magnetic flux density of 1 mT or more. When installing an electric actuator and an air cylinder with an auto switch (ex. CDQ2 series) or multiple electric actuators side by side, maintain a space of 40 mm or more around the motor. Refer to the construction drawing of the actuator motor.

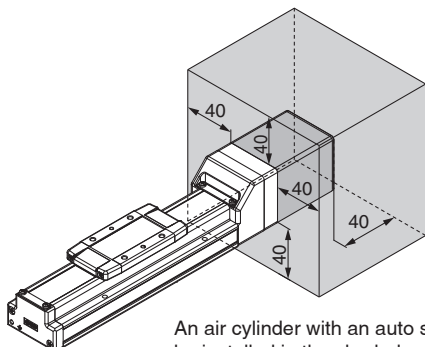

An air cylinder with an auto switch cannot be installed in the shaded area.

● When lining up actuators

SMC actuators can be used with their motors adjacent to each other. However, for actuators with a built-in auto switch magnet (the LEY and LEF series), maintain a space of 40 mm or more between the motors and the position where the magnet passes. For the LEF series, the magnet is in the middle of the table, and for the LEY series, the magnet is in the piston portion. (Refer to the construction drawings in the catalogue for details.)

○ Can be used with their motors adjacent to each other

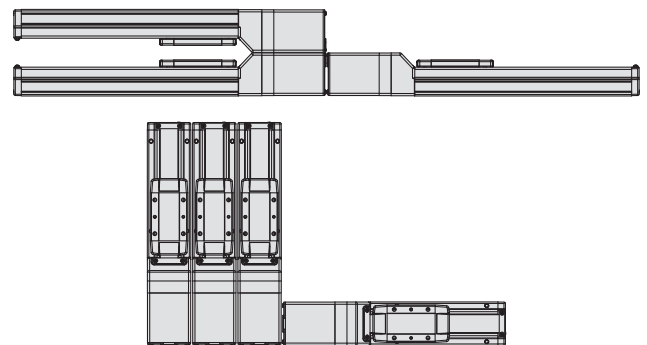

✗ Do not allow the motors to be in close proximity to the position where the magnet passes.

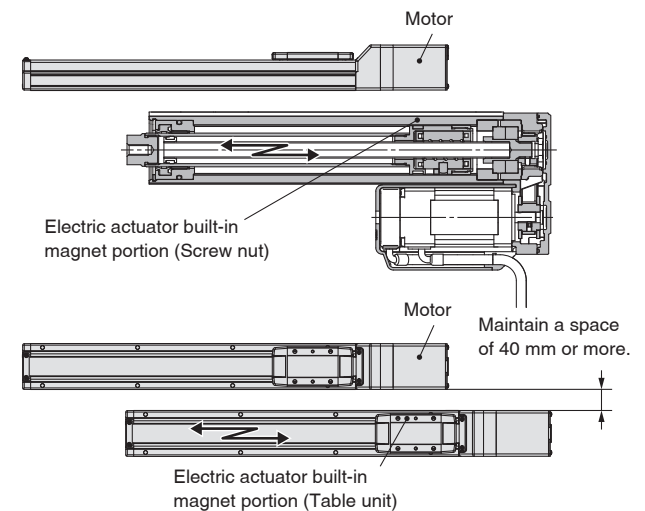

3. The connector size of the motor cable is different from that of the electric actuator with an incremental encoder.

The motor cable connector of an electric actuator with a battery-less absolute encoder is different from that of an electric actuator with an incremental encoder. As the connector cover dimensions are different, take the dimensions below into consideration during the design process.

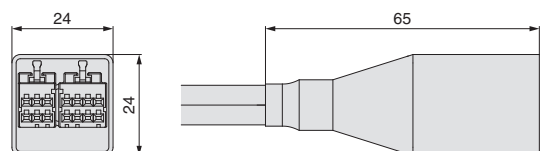

Battery-less absolute encoder connector cover dimensions

CE/UKCA/UL-compliance List

* For CE, UKCA, and UL-compliant products, refer to the tables below and the following pages.

■ Controllers “○”: Compliant “x”: Not compliant

As of November 2021

| Compatible motor | Series | CE UKCA | | cULus | | Compatible motor | Series | CE UKCA | | cULus LISTED | |
|--------------------------------------|----------|------------|------------------------------|------------|------------------------------|--|---------|------------|------------------------------|--------------|------------------------------|
| | | Compliance | Certification No. (File No.) | Compliance | Certification No. (File No.) | | | Compliance | Certification No. (File No.) | Compliance | Certification No. (File No.) |
| Step motor (Incremental) | JXCE1 | ○ | ○ | ○ | E480340 | AC servo motor | LECSA | ○ | ○ | ○ | E466261 |
| | JXC91 | ○ | ○ | ○ | E480340 | | LECSB | ○ | x | — | — |
| | JXCP1 | ○ | ○ | ○ | E480340 | | LECSA | ○ | x | — | — |
| | JXCD1 | ○ | ○ | ○ | E480340 | | LECSB | ○ | x | — | — |
| | JXCL1 | ○ | ○ | ○ | E480340 | | LECSB-T | ○ | ○ | ○ | E466261 |
| | JXCLF | ○ | ○ | ○ | E480340 | | LECSA-T | ○ | ○ | ○ | E466261 |
| | LECP1 | ○ | ○ | ○ | E339743 | | LECSN-T | ○ | ○*1 | ○ | E466261 |
| | LECP2 | ○ | ○ | ○ | E339743 | | LECSS-T | ○ | ○ | ○ | E466261 |
| | LECPA | ○ | ○ | ○ | E339743 | | LECYM | ○ | x | — | — |
| JXC51/61 | ○ | ○ | ○ | E480340 | LECYU | | ○ | x | — | — | |
| Step motor (Battery-less absolute) | JXCE1 | ○ | ○ | ○ | E480340 | *1 Only the “Without network card” option is UL compliant. | | | | | |
| | JXC91 | ○ | ○ | ○ | E480340 | | | | | | |
| | JXCP1 | ○ | ○ | ○ | E480340 | | | | | | |
| | JXCD1 | ○ | ○ | ○ | E480340 | | | | | | |
| | JXCL1 | ○ | ○ | ○ | E480340 | | | | | | |
| | JXCLF | ○ | ○ | ○ | E480340 | | | | | | |
| High performance step motor (24 VDC) | JXCM1 | ○ | ○ | ○ | E480340 | | | | | | |
| | JXC5H/6H | ○ | ○ | ○ | E480340 | | | | | | |
| | JXCEH | ○ | ○ | ○ | E480340 | | | | | | |
| | JXC9H | ○ | ○ | ○ | E480340 | | | | | | |
| Servo motor (24 VDC) | JXCPH | ○ | ○ | ○ | E480340 | | | | | | |
| | LECA6 | ○ | ○ | ○ | E339743 | | | | | | |
| Multi-axis step motor controller | JXC73 | ○ | x | — | — | | | | | | |
| | JXC83 | ○ | x | — | — | | | | | | |
| | JXC93 | ○ | x | — | — | | | | | | |
| | JXC92 | ○ | x | — | — | | | | | | |

■ Actuators “○”: Compliant “x”: Not compliant

As of November 2021

| Compatible motor | Series | CE UKCA | | cULus | | Compatible motor | Series | CE UKCA | | cULus | |
|------------------------------------|-----------|------------|------------------------------|------------|------------------------------|--------------------------------------|----------------------|------------|------------------------------|------------|------------------------------|
| | | Compliance | Certification No. (File No.) | Compliance | Certification No. (File No.) | | | Compliance | Certification No. (File No.) | Compliance | Certification No. (File No.) |
| Step motor (Incremental) | LEFS | ○ | x | — | — | High performance step motor (24 VDC) | LEFS | ○ | x | — | — |
| | 11-LEFS | ○ | x | — | — | | Servo motor (24 VDC) | LEFS | ○ | x | — |
| | 25A-LEFS | ○ | x | — | — | 11-LEFS | | ○ | x | — | — |
| | LEFB | ○ | x | — | — | 25A-LEFS | | ○ | x | — | — |
| | LEL | ○ | x | — | — | LEFB | | ○ | x | — | — |
| | LEM | ○ | x | — | — | LEY | | ○ | x | — | — |
| | LEY | ○ | x | — | — | 25A-LEY | | ○ | x | — | — |
| | 25A-LEY | ○ | x | — | — | LEY-X5/X7 | | ○ | x | — | — |
| | LEY-X5/X7 | ○ | x | — | — | LEYG | | ○ | x | — | — |
| | LEYG | ○ | x | — | — | LES | | ○ | x | — | — |
| | LES | ○ | x | — | — | LESH | | ○ | x | — | — |
| | LESH | ○ | x | — | — | LEPY | ○ | x | — | — | |
| | LEPY | ○ | x | — | — | LEPS | ○ | x | — | — | |
| | LEPS | ○ | x | — | — | LER | ○ | x | — | — | |
| | LER | ○ | x | — | — | LEHZ | ○ | x | — | — | |
| | LEHZ | ○ | x | — | — | LEHZJ | ○ | x | — | — | |
| | LEHZJ | ○ | x | — | — | LEHF | ○ | x | — | — | |
| | LEHF | ○ | x | — | — | LEHS | ○ | x | — | — | |
| | LEHS | ○ | x | — | — | AC servo motor | LEFS | ○ | x | — | — |
| Step motor (Battery-less absolute) | LEFS | ○ | x | — | — | | 11-LEFS | ○ | x | — | — |
| | LEFB | ○ | x | — | — | | 25A-LEFS | ○ | x | — | — |
| | LEKFS | ○ | x | — | — | | LEFB | ○ | x | — | — |
| | LEY | ○ | x | — | — | | LEJS | ○ | x | — | — |
| | LEY-X8 | ○ | x | — | — | | 11-LEJS | ○ | x | — | — |
| | LEYG | ○ | x | — | — | | 25A-LEJS | ○ | x | — | — |
| | LES | ○ | x | — | — | | LEJB | ○ | x | — | — |
| | LESH | ○ | x | — | — | | LEY25/32/63 | ○ | x | — | — |
| | LESYH | ○ | x | — | — | | LEY100 | ○ | x | — | — |
| | LER | ○ | x | — | — | | LEYG | ○ | x | — | — |
| | LEHF | ○ | x | — | — | | LESYH | ○ | x | — | — |

* Actuators ordered as single units are not UL compliant.

■ Actuators (When ordered with a controller) “○”: Compliant “x”: Not compliant “—”: Not applicable As of November 2021

| Compatible motor | Series | JXC51/61 | | | JXCE1 | | | JXC91 | | | JXCP1 | | | JXCD1 | | |
|-----------------------------|-----------|----------------|-------------------|------------------------------|----------------|-------------------|------------------------------|----------------|-------------------|------------------------------|----------------|-------------------|------------------------------|----------------|-------------------|------------------------------|
| | | CE UK CA | cRU ^{us} | | CE UK CA | cRU ^{us} | | CE UK CA | cRU ^{us} | | CE UK CA | cRU ^{us} | | CE UK CA | cRU ^{us} | |
| | | | Compliance | Certification No. (File No.) | | Compliance | Certification No. (File No.) | | Compliance | Certification No. (File No.) | | Compliance | Certification No. (File No.) | | Compliance | Certification No. (File No.) |
| Step motor (Incremental) | LEFS | ○ | ○ | E339743 | ○ | ○ | E339743 | ○ | ○ | E339743 | ○ | ○ | E339743 | ○ | ○ | E339743 |
| | 11-LEFS | ○ | ○ | E339743 | ○ | ○ | E339743 | ○ | ○ | E339743 | ○ | ○ | E339743 | ○ | ○ | E339743 |
| | 25A-LEFS | ○ | ○ | E339743 | ○ | ○ | E339743 | ○ | ○ | E339743 | ○ | ○ | E339743 | ○ | ○ | E339743 |
| | LEFB | ○ | ○ | E339743 | ○ | ○ | E339743 | ○ | ○ | E339743 | ○ | ○ | E339743 | ○ | ○ | E339743 |
| | LEL | ○ | ○ | E339743 | ○ | ○ | E339743 | ○ | ○ | E339743 | ○ | ○ | E339743 | ○ | ○ | E339743 |
| | LEM | ○ | ○ | E339743 | ○ | ○ | E339743 | ○ | ○ | E339743 | ○ | ○ | E339743 | ○ | ○ | E339743 |
| | LEY | ○ | ○ | E339743 | ○ | ○ | E339743 | ○ | ○ | E339743 | ○ | ○ | E339743 | ○ | ○ | E339743 |
| | 25A-LEY | ○ | ○ | E339743 | ○ | ○ | E339743 | ○ | ○ | E339743 | ○ | ○ | E339743 | ○ | ○ | E339743 |
| | LEY-X5/X7 | ○ | x | — | ○ | x | — | ○ | x | — | ○ | x | — | ○ | x | — |
| | LEYG | ○ | ○ | E339743 | ○ | ○ | E339743 | ○ | ○ | E339743 | ○ | ○ | E339743 | ○ | ○ | E339743 |
| | LES | ○ | ○ | E339743 | ○ | ○ | E339743 | ○ | ○ | E339743 | ○ | ○ | E339743 | ○ | ○ | E339743 |
| | LESH | ○ | ○ | E339743 | ○ | ○ | E339743 | ○ | ○ | E339743 | ○ | ○ | E339743 | ○ | ○ | E339743 |
| | LEPY | ○ | ○ | E339743 | ○ | ○ | E339743 | ○ | ○ | E339743 | ○ | ○ | E339743 | ○ | ○ | E339743 |
| | LEPS | ○ | ○ | E339743 | ○ | ○ | E339743 | ○ | ○ | E339743 | ○ | ○ | E339743 | ○ | ○ | E339743 |
| | LER | ○ | ○ | E339743 | ○ | ○ | E339743 | ○ | ○ | E339743 | ○ | ○ | E339743 | ○ | ○ | E339743 |
| | LEHZ | ○ | ○ | E339743 | ○ | ○ | E339743 | ○ | ○ | E339743 | ○ | ○ | E339743 | ○ | ○ | E339743 |
| | LEHZJ | ○ | ○ | E339743 | ○ | ○ | E339743 | ○ | ○ | E339743 | ○ | ○ | E339743 | ○ | ○ | E339743 |
| LEHF | ○ | ○ | E339743 | ○ | ○ | E339743 | ○ | ○ | E339743 | ○ | ○ | E339743 | ○ | ○ | E339743 | |
| LEHS | ○ | ○ | E339743 | ○ | ○ | E339743 | ○ | ○ | E339743 | ○ | ○ | E339743 | ○ | ○ | E339743 | |

| Compatible motor | Series | JXCL1 | | | JXCLF | | | JXCM1 | | | LECP1 | | | LECP2 | | |
|-----------------------------|-----------|----------------|-------------------|------------------------------|----------------|-------------------|------------------------------|----------------|-------------------|------------------------------|----------------|-------------------|------------------------------|----------------|-------------------|------------------------------|
| | | CE UK CA | cRU ^{us} | | CE UK CA | cRU ^{us} | | CE UK CA | cRU ^{us} | | CE UK CA | cRU ^{us} | | CE UK CA | cRU ^{us} | |
| | | | Compliance | Certification No. (File No.) | | Compliance | Certification No. (File No.) | | Compliance | Certification No. (File No.) | | Compliance | Certification No. (File No.) | | Compliance | Certification No. (File No.) |
| Step motor (Incremental) | LEFS | ○ | ○ | E339743 | ○ | ○ | E339743 | ○ | ○ | E339743 | ○ | ○ | E339743 | x | x | — |
| | 11-LEFS | ○ | ○ | E339743 | ○ | ○ | E339743 | ○ | ○ | E339743 | ○ | ○ | E339743 | x | x | — |
| | 25A-LEFS | ○ | ○ | E339743 | ○ | ○ | E339743 | ○ | ○ | E339743 | ○ | ○ | E339743 | x | x | — |
| | LEFB | ○ | ○ | E339743 | ○ | ○ | E339743 | ○ | ○ | E339743 | ○ | ○ | E339743 | x | x | — |
| | LEL | ○ | ○ | E339743 | ○ | ○ | E339743 | ○ | ○ | E339743 | ○ | ○ | E339743 | x | x | — |
| | LEM | ○ | ○ | E339743 | ○ | ○ | E339743 | ○ | ○ | E339743 | ○ | ○ | E339743 | ○ | ○ | E339743 |
| | LEY | ○ | ○ | E339743 | ○ | ○ | E339743 | ○ | ○ | E339743 | ○ | ○ | E339743 | x | x | — |
| | 25A-LEY | ○ | ○ | E339743 | ○ | ○ | E339743 | ○ | ○ | E339743 | ○ | ○ | E339743 | x | x | — |
| | LEY-X5/X7 | ○ | x | — | ○ | ○ | E339743 | ○ | x | — | ○ | x | — | x | x | — |
| | LEYG | ○ | ○ | E339743 | ○ | ○ | E339743 | ○ | ○ | E339743 | ○ | ○ | E339743 | x | x | — |
| | LES | ○ | ○ | E339743 | ○ | ○ | E339743 | ○ | ○ | E339743 | ○ | ○ | E339743 | x | x | — |
| | LESH | ○ | ○ | E339743 | ○ | ○ | E339743 | ○ | ○ | E339743 | ○ | ○ | E339743 | x | x | — |
| | LEPY | ○ | ○ | E339743 | ○ | ○ | E339743 | ○ | ○ | E339743 | ○ | ○ | E339743 | x | x | — |
| | LEPS | ○ | ○ | E339743 | ○ | ○ | E339743 | ○ | ○ | E339743 | ○ | ○ | E339743 | x | x | — |
| | LER | ○ | ○ | E339743 | ○ | ○ | E339743 | ○ | ○ | E339743 | ○ | ○ | E339743 | x | x | — |
| | LEHZ | ○ | ○ | E339743 | ○ | ○ | E339743 | ○ | ○ | E339743 | ○ | ○ | E339743 | x | x | — |
| | LEHZJ | ○ | ○ | E339743 | ○ | ○ | E339743 | ○ | ○ | E339743 | ○ | ○ | E339743 | x | x | — |
| LEHF | ○ | ○ | E339743 | ○ | ○ | E339743 | ○ | ○ | E339743 | ○ | ○ | E339743 | x | x | — | |
| LEHS | ○ | ○ | E339743 | ○ | ○ | E339743 | ○ | ○ | E339743 | ○ | ○ | E339743 | x | x | — | |

| Compatible motor | Series | LECPA | | |
|-----------------------------|-----------|----------------|-------------------|------------------------------|
| | | CE UK CA | cRU ^{us} | |
| | | | Compliance | Certification No. (File No.) |
| Step motor (Incremental) | LEFS | ○ | ○ | E339743 |
| | 11-LEFS | ○ | ○ | E339743 |
| | 25A-LEFS | ○ | ○ | E339743 |
| | LEFB | ○ | ○ | E339743 |
| | LEL | ○ | ○ | E339743 |
| | LEM | ○ | ○ | E339743 |
| | LEY | ○ | ○ | E339743 |
| | 25A-LEY | ○ | ○ | E339743 |
| | LEY-X5/X7 | ○ | x | — |
| | LEYG | ○ | ○ | E339743 |
| | LES | ○ | ○ | E339743 |
| | LESH | ○ | ○ | E339743 |
| | LEPY | ○ | ○ | E339743 |
| | LEPS | ○ | ○ | E339743 |
| | LER | ○ | ○ | E339743 |
| | LEHZ | ○ | ○ | E339743 |
| | LEHZJ | ○ | ○ | E339743 |
| LEHF | ○ | ○ | E339743 | |
| LEHS | ○ | ○ | E339743 | |

CE/UKCA/UL-compliance List

■ Actuators (When ordered with a controller) “○”: Compliant “x”: Not compliant “—”: Not applicable As of November 2021

| Compatible motor | Series | JXC51/61 | | | JXCE1 | | | JXC91 | | | JXCP1 | | | JXCD1 | | |
|--|--------|----------------|-------------------|------------------------------|----------------|-------------------|------------------------------|----------------|-------------------|------------------------------|----------------|-------------------|------------------------------|----------------|-------------------|------------------------------|
| | | CE UK CA | cRU ^{us} | | CE UK CA | cRU ^{us} | | CE UK CA | cRU ^{us} | | CE UK CA | cRU ^{us} | | CE UK CA | cRU ^{us} | |
| | | | Compliance | Certification No. (File No.) | | Compliance | Certification No. (File No.) | | Compliance | Certification No. (File No.) | | Compliance | Certification No. (File No.) | | Compliance | Certification No. (File No.) |
| Step motor (Battery-less absolute) | LEFS | ○ | x | — | ○ | x | — | ○ | x | — | ○ | x | — | ○ | x | — |
| | LEFB | ○ | x | — | ○ | x | — | ○ | x | — | ○ | x | — | ○ | x | — |
| | LEKFS | ○ | x | — | ○ | x | — | ○ | x | — | ○ | x | — | ○ | x | — |
| | LEY | ○ | x | — | ○ | x | — | ○ | x | — | ○ | x | — | ○ | x | — |
| | LEY-X8 | ○ | x | — | ○ | x | — | ○ | x | — | ○ | x | — | ○ | x | — |
| | LEYG | ○ | x | — | ○ | x | — | ○ | x | — | ○ | x | — | ○ | x | — |
| | LES | ○ | x | — | ○ | x | — | ○ | x | — | ○ | x | — | ○ | x | — |
| | LESH | ○ | x | — | ○ | x | — | ○ | x | — | ○ | x | — | ○ | x | — |
| | LESYH | ○ | x | — | ○ | x | — | ○ | x | — | ○ | x | — | ○ | x | — |
| | LER | ○ | x | — | ○ | x | — | ○ | x | — | ○ | x | — | ○ | x | — |
| LEHF | ○ | x | — | ○ | x | — | ○ | x | — | ○ | x | — | ○ | x | — | |

| Compatible motor | Series | JXCL1 | | JXCLF | | JXCM1 | | | | |
|--|--------|----------------|-------------------|----------------|------------------------------|----------------|-------------------|------------------------------|------------|------------------------------|
| | | CE UK CA | cRU ^{us} | CE UK CA | cRU ^{us} | CE UK CA | cRU ^{us} | | | |
| | | | Compliance | | Certification No. (File No.) | | Compliance | Certification No. (File No.) | Compliance | Certification No. (File No.) |
| Step motor (Battery-less absolute) | LEFS | ○ | x | — | ○ | x | — | ○ | x | — |
| | LEFB | ○ | x | — | ○ | x | — | ○ | x | — |
| | LEKFS | ○ | x | — | ○ | x | — | ○ | x | — |
| | LEY | ○ | x | — | ○ | x | — | ○ | x | — |
| | LEY-X8 | ○ | x | — | ○ | x | — | ○ | x | — |
| | LEYG | ○ | x | — | ○ | x | — | ○ | x | — |
| | LES | ○ | x | — | ○ | x | — | ○ | x | — |
| | LESH | ○ | x | — | ○ | x | — | ○ | x | — |
| | LESYH | ○ | x | — | ○ | x | — | ○ | x | — |
| | LER | ○ | x | — | ○ | x | — | ○ | x | — |
| LEHF | ○ | x | — | ○ | x | — | ○ | x | — | |

CE/UKCA/UL-compliance List

■ Actuators (When ordered with a controller) "O": Compliant "x": Not compliant "—": Not applicable As of November 2021

| Compatible motor | Series | JXC5H/6H | | | JXCEH | | | JXC9H | | | JXCPH | | |
|--------------------------------------|--------|----------------|-------------------|------------------------------|----------------|-------------------|------------------------------|----------------|-------------------|------------------------------|----------------|-------------------|------------------------------|
| | | CE UK CA | cRU ^{us} | | CE UK CA | cRU ^{us} | | CE UK CA | cRU ^{us} | | CE UK CA | cRU ^{us} | |
| | | | Compliance | Certification No. (File No.) | | Compliance | Certification No. (File No.) | | Compliance | Certification No. (File No.) | | Compliance | Certification No. (File No.) |
| High performance step motor (24 VDC) | LEF | O | O | E339743 | O | O | E339743 | O | O | E339743 | O | O | E339743 |

| Compatible motor | Series | JXC5H/6H | | | JXCEH | | | JXC9H | | | JXCPH | | |
|--|--------|----------------|-------------------|------------------------------|----------------|-------------------|------------------------------|----------------|-------------------|------------------------------|----------------|-------------------|------------------------------|
| | | CE UK CA | cRU ^{us} | | CE UK CA | cRU ^{us} | | CE UK CA | cRU ^{us} | | CE UK CA | cRU ^{us} | |
| | | | Compliance | Certification No. (File No.) | | Compliance | Certification No. (File No.) | | Compliance | Certification No. (File No.) | | Compliance | Certification No. (File No.) |
| High performance (Battery-less absolute) | LEF | O | x | — | O | x | — | O | x | — | O | x | — |

| Compatible motor | Series | LECA6 | | |
|----------------------|----------|----------------|-------------------|------------------------------|
| | | CE UK CA | cRU ^{us} | |
| | | | Compliance | Certification No. (File No.) |
| Servo motor (24 VDC) | LEFS | O | O | E339743 |
| | 11-LEFS | O | O | E339743 |
| | 25A-LEFS | O | O | E339743 |
| | LEFB | O | O | E339743 |
| | LEY | O | O | E339743 |
| | LEY-X7 | O | x | — |
| | LEYG | O | O | E339743 |
| | LES | O | O | E339743 |
| | LESH | O | O | E339743 |



| Compatible motor | Series | LECSA*1 | | | LECSB | | | LECSC | | | LECSS | | | LECSB-T*1 | | |
|------------------|-------------|----------------|-------------------|------------------------------|----------------|-------------------|------------------------------|----------------|-------------------|------------------------------|----------------|-------------------|------------------------------|----------------|-------------------|------------------------------|
| | | CE UK CA | cRU ^{us} | | CE UK CA | cRU ^{us} | | CE UK CA | cRU ^{us} | | CE UK CA | cRU ^{us} | | CE UK CA | cRU ^{us} | |
| | | | Compliance | Certification No. (File No.) | | Compliance | Certification No. (File No.) | | Compliance | Certification No. (File No.) | | Compliance | Certification No. (File No.) | | Compliance | Certification No. (File No.) |
| AC servo motor | LEFS | O | O | E339743 | O | x | — | O | x | — | O | x | — | O | x | — |
| | 11-LEFS | O | O | E339743 | O | x | — | O | x | — | O | x | — | O | x | — |
| | 25A-LEFS | O | O | E339743 | O | x | — | O | x | — | O | x | — | O | x | — |
| | LEFB | O | O | E339743 | O | x | — | O | x | — | O | x | — | O | x | — |
| | LEJS | O | O | E339743 | O | x | — | O | x | — | O | x | — | O | x | — |
| | 11-LEJS | O | O | E339743 | O | x | — | O | x | — | O | x | — | O | x | — |
| | 25A-LEJS | O | O | E339743 | O | x | — | O | x | — | O | x | — | O | x | — |
| | LEJB | O | O | E339743 | O | x | — | O | x | — | O | x | — | O | x | — |
| | LEY25/32/63 | O | O | E339743 | O | x | — | O | x | — | O | x | — | O | x | — |
| | LEY100 | — | — | — | — | — | — | — | — | — | — | — | — | — | — | — |
| | LEYG | O | O | E339743 | O | x | — | O | x | — | O | x | — | O | x | — |
| | LESYH | O | x | — | — | — | — | — | — | — | — | — | — | O | x | — |

| Compatible motor | Series | LECSC-T*1 | | | LECSN-T*1 | | | LECSS-T*1 | | |
|------------------|-------------|----------------|-------------------|------------------------------|----------------|-------------------|------------------------------|----------------|-------------------|------------------------------|
| | | CE UK CA | cRU ^{us} | | CE UK CA | cRU ^{us} | | CE UK CA | cRU ^{us} | |
| | | | Compliance | Certification No. (File No.) | | Compliance | Certification No. (File No.) | | Compliance | Certification No. (File No.) |
| AC servo motor | LEFS | O | x | — | O | x | — | O | O | E339743 |
| | 11-LEFS | O | x | — | O | x | — | O | O | E339743 |
| | 25A-LEFS | O | x | — | O | x | — | O | O | E339743 |
| | LEFB | O | x | — | O | x | — | O | O | E339743 |
| | LEJS | O | x | — | O | x | — | O | O | E339743 |
| | 11-LEJS | O | x | — | O | x | — | O | O | E339743 |
| | 25A-LEJS | O | x | — | O | x | — | O | O | E339743 |
| | LEJB | O | x | — | O | x | — | O | O | E339743 |
| | LEY25/32/63 | O | x | — | O | x | — | O | O | E339743 |
| | LEY100 | O | x | — | O | x | — | O | x | — |
| | LEYG | O | x | — | O | x | — | O | O | E339743 |
| | LESYH | O | x | — | O | x | — | O | x | — |

*1 There is a "UL Listed" mark on the AC servo motor driver body.

Safety Instructions

These safety instructions are intended to prevent hazardous situations and/or equipment damage. These instructions indicate the level of potential hazard with the labels of “Caution,” “Warning” or “Danger.” They are all important notes for safety and must be followed in addition to International Standards (ISO/IEC)¹⁾, and other safety regulations.

-  **Caution:** **Caution** indicates a hazard with a low level of risk which, if not avoided, could result in minor or moderate injury.
-  **Warning:** **Warning** indicates a hazard with a medium level of risk which, if not avoided, could result in death or serious injury.
-  **Danger:** **Danger** indicates a hazard with a high level of risk which, if not avoided, will result in death or serious injury.

- 1) ISO 4414: Pneumatic fluid power – General rules relating to systems.
ISO 4413: Hydraulic fluid power – General rules relating to systems.
IEC 60204-1: Safety of machinery – Electrical equipment of machines.
(Part 1: General requirements)
- ISO 10218-1: Manipulating industrial robots - Safety.
etc.

Warning

1. The compatibility of the product is the responsibility of the person who designs the equipment or decides its specifications.

Since the product specified here is used under various operating conditions, its compatibility with specific equipment must be decided by the person who designs the equipment or decides its specifications based on necessary analysis and test results. The expected performance and safety assurance of the equipment will be the responsibility of the person who has determined its compatibility with the product. This person should also continuously review all specifications of the product referring to its latest catalogue information, with a view to giving due consideration to any possibility of equipment failure when configuring the equipment.

2. Only personnel with appropriate training should operate machinery and equipment.

The product specified here may become unsafe if handled incorrectly. The assembly, operation and maintenance of machines or equipment including our products must be performed by an operator who is appropriately trained and experienced.

3. Do not service or attempt to remove product and machinery/equipment until safety is confirmed.

1. The inspection and maintenance of machinery/equipment should only be performed after measures to prevent falling or runaway of the driven objects have been confirmed.
2. When the product is to be removed, confirm that the safety measures as mentioned above are implemented and the power from any appropriate source is cut, and read and understand the specific product precautions of all relevant products carefully.
3. Before machinery/equipment is restarted, take measures to prevent unexpected operation and malfunction.

4. Contact SMC beforehand and take special consideration of safety measures if the product is to be used in any of the following conditions.

1. Conditions and environments outside of the given specifications, or use outdoors or in a place exposed to direct sunlight.
2. Installation on equipment in conjunction with atomic energy, railways, air navigation, space, shipping, vehicles, military, medical treatment, combustion and recreation, or equipment in contact with food and beverages, emergency stop circuits, clutch and brake circuits in press applications, safety equipment or other applications unsuitable for the standard specifications described in the product catalogue.
3. An application which could have negative effects on people, property, or animals requiring special safety analysis.
4. Use in an interlock circuit, which requires the provision of double interlock for possible failure by using a mechanical protective function, and periodical checks to confirm proper operation.

Caution

1. The product is provided for use in manufacturing industries.

The product herein described is basically provided for peaceful use in manufacturing industries.

If considering using the product in other industries, consult SMC beforehand and exchange specifications or a contract if necessary. If anything is unclear, contact your nearest sales branch.

Limited warranty and Disclaimer/Compliance Requirements

The product used is subject to the following “Limited warranty and Disclaimer” and “Compliance Requirements”. Read and accept them before using the product.

Limited warranty and Disclaimer

1. The warranty period of the product is 1 year in service or 1.5 years after the product is delivered, whichever is first.²⁾ Also, the product may have specified durability, running distance or replacement parts. Please consult your nearest sales branch.
 2. For any failure or damage reported within the warranty period which is clearly our responsibility, a replacement product or necessary parts will be provided. This limited warranty applies only to our product independently, and not to any other damage incurred due to the failure of the product.
 3. Prior to using SMC products, please read and understand the warranty terms and disclaimers noted in the specified catalogue for the particular products.
- 2) Vacuum pads are excluded from this 1 year warranty.
A vacuum pad is a consumable part, so it is warranted for a year after it is delivered. Also, even within the warranty period, the wear of a product due to the use of the vacuum pad or failure due to the deterioration of rubber material are not covered by the limited warranty.

Compliance Requirements

1. The use of SMC products with production equipment for the manufacture of weapons of mass destruction (WMD) or any other weapon is strictly prohibited.
2. The exports of SMC products or technology from one country to another are governed by the relevant security laws and regulations of the countries involved in the transaction. Prior to the shipment of a SMC product to another country, assure that all local rules governing that export are known and followed.

Caution

SMC products are not intended for use as instruments for legal metrology.

Measurement instruments that SMC manufactures or sells have not been qualified by type approval tests relevant to the metrology (measurement) laws of each country. Therefore, SMC products cannot be used for business or certification ordained by the metrology (measurement) laws of each country.

Safety Instructions

Be sure to read “Handling Precautions for SMC Products” (M-E03-3) before using.

SMC Corporation (Europe)

| | | | |
|-----------------------|-------------------|----------------------|-----------------------------|
| Austria | +43 (0)2262622800 | www.smc.at | office@smc.at |
| Belgium | +32 (0)33551464 | www.smc.be | info@smc.be |
| Bulgaria | +359 (0)2807670 | www.smc.bg | office@smc.bg |
| Croatia | +385 (0)13707288 | www.smc.hr | office@smc.hr |
| Czech Republic | +420 541424611 | www.smc.cz | office@smc.cz |
| Denmark | +45 70252900 | www.smc.dk.com | smc@smcdk.com |
| Estonia | +372 651 0370 | www.smcee.ee | info@smcee.ee |
| Finland | +358 207513513 | www.smc.fi | smc.fi@smc.fi |
| France | +33 (0)164761000 | www.smc-france.fr | supportclient@smc-france.fr |
| Germany | +49 (0)61034020 | www.smc.de | info@smc.de |
| Greece | +30 210 2717265 | www.smchellas.gr | sales@smchellas.gr |
| Hungary | +36 23513000 | www.smc.hu | office@smc.hu |
| Ireland | +353 (0)14039000 | www.smcautomation.ie | sales@smcautomation.ie |
| Italy | +39 03990691 | www.smcitalia.it | mailbox@smcitalia.it |
| Latvia | +371 67817700 | www.smc.lv | info@smc.lv |

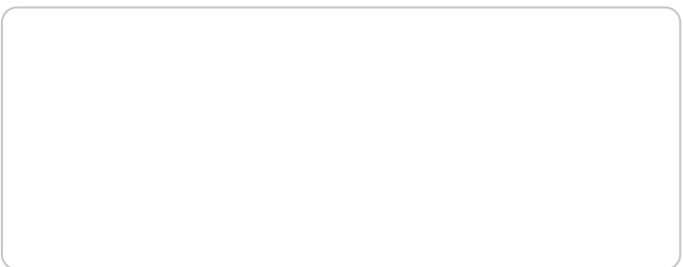

| | | | |
|---------------------|---------------------|----------------------|-----------------------------|
| Lithuania | +370 5 2308118 | www.smclt.lt | info@smclt.lt |
| Netherlands | +31 (0)205318888 | www.smc.nl | info@smc.nl |
| Norway | +47 67129020 | www.smc-norge.no | post@smc-norge.no |
| Poland | +48 222119600 | www.smc.pl | office@smc.pl |
| Portugal | +351 214724500 | www.smc.eu | apoioclientept@smc.smces.es |
| Romania | +40 213205111 | www.smcromania.ro | smcromania@smcromania.ro |
| Russia | +7 (812)3036600 | www.smc.eu | sales@smcru.com |
| Slovakia | +421 (0)413213212 | www.smc.sk | office@smc.sk |
| Slovenia | +386 (0)73885412 | www.smc.si | office@smc.si |
| Spain | +34 945184100 | www.smc.eu | post@smc.smces.es |
| Sweden | +46 (0)86031240 | www.smc.nu | smc@smc.nu |
| Switzerland | +41 (0)523963131 | www.smc.ch | info@smc.ch |
| Turkey | +90 212 489 0 440 | www.smcturkey.com.tr | satis@smcturkey.com.tr |
| UK | +44 (0)845 121 5122 | www.smc.uk | sales@smc.uk |
| South Africa | +27 10 900 1233 | www.smcza.co.za | zasales@smcza.co.za |