

# With Input Signals to Perform Jog Operations

## Step Motor Controller



### Jog operation can be performed using parallel input signals.

Jog operations that could previously only be performed using the button on the front face can now be performed using the ON/OFF status of the input signal.

\* Input signals "JOG+" and "JOG-" are used as motion instructions.

### Application Examples

Optimal for adjusting the feed value using a button operation while checking the motion of the actuator

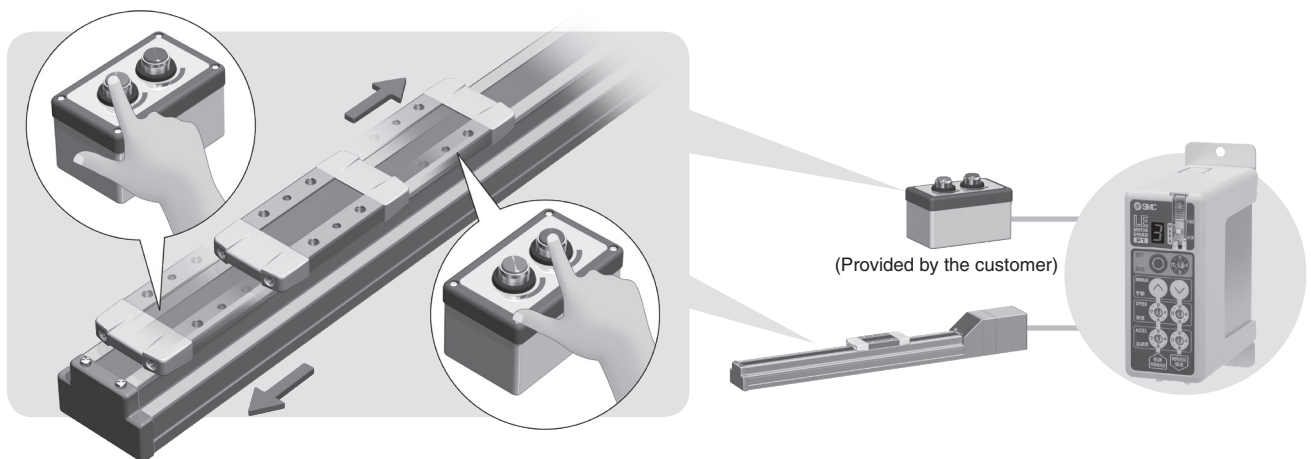

Specifications not listed are the same as those of the standard product. For details, refer to the [Web Catalogue](#).

### Specifications

Model	<b>LECP1□-□-XB182</b>	
Compatible motor	Step motor (Servo/24 VDC)	
Power supply	Power voltage: 24 VDC ±10 %*1 [Including motor drive power, control power, stop, lock release]	
Parallel input	6 inputs (Photo-coupler isolation)	
Parallel output	6 outputs (Photo-coupler isolation)	
Function	Number of positioning points	2 points
	Jog input	Yes
Operating temperature range [°C]	0 to 40 (No freezing)	
Operating humidity range [%RH]	90 or less (No condensation)	
Storage temperature range [°C]	-10 to 60 (No freezing)	
Storage humidity range [%RH]	90 or less (No condensation)	
Weight [g]	130 (Screw mounting),	
	150 (DIN rail mounting)	

\*1 The power consumption changes depending on the actuator model. Refer to the actuator specifications for more details.

### Control Timing Chart

#### Jog

#### – Procedure –

- ① When an alarm is not being generated (ALARM output ON), and the STOP input is OFF, set the JOG- input or the JOG+ input to ON.
- ② The OUTJ- output or the OUTJ+ output goes ON, and motion starts. The BUSY output goes ON.
- ③ Set the JOG- input or the JOG+ input to OFF.
- ④ The OUTJ- output or the OUTJ+ output goes OFF, and speed reduction starts.
- ⑤ Motion stops, and the BUSY output goes OFF.

\* A JOG- input and a JOG+ input cannot be turned ON simultaneously.

#### – Timing Chart –

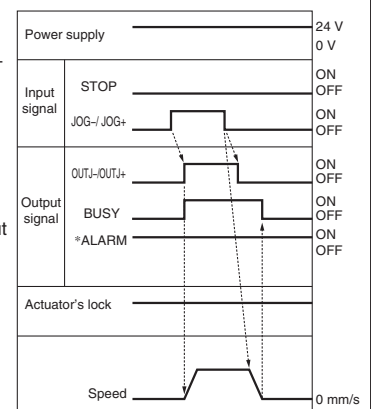

\* \*\*ALARM\*\* is expressed as a negative-logic circuit.

# LECP1-XB182



19-EU710-UK

# LECP1-XB182

## How to Order

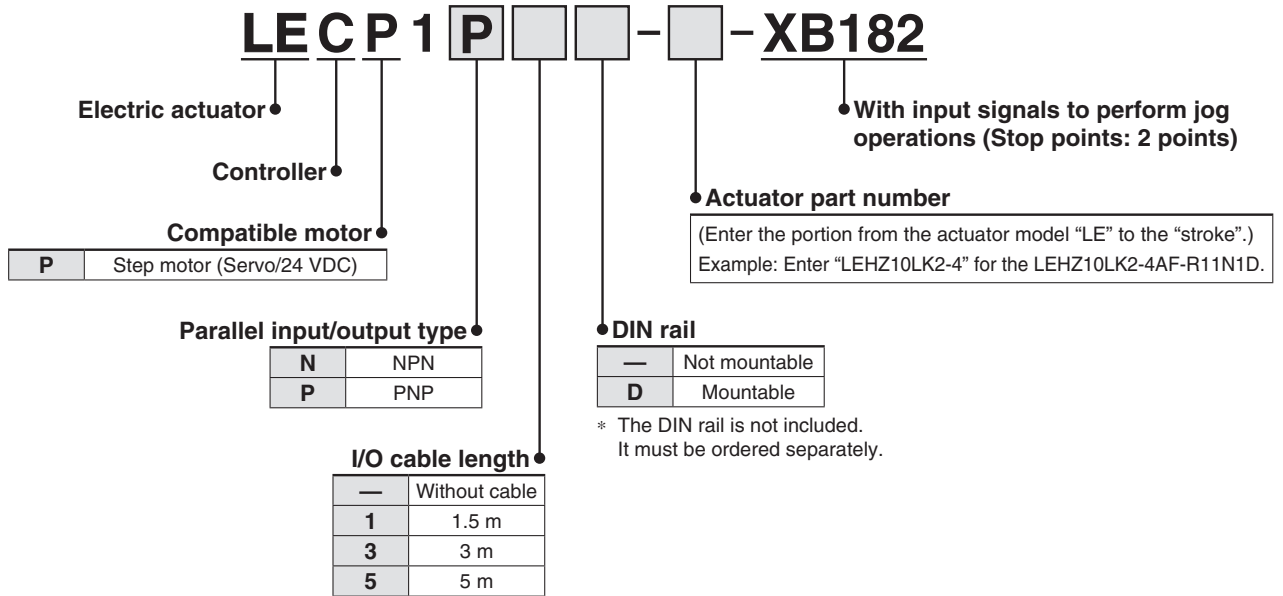

## Wiring Diagram

**Parallel I/O connector: CN4** \* When you connect a PLC to the CN4 parallel I/O connector, use the I/O cable (LEC-CK4-□).  
 \* The wiring changes depending on the type of parallel I/O (NPN or PNP).

### ■ NPN

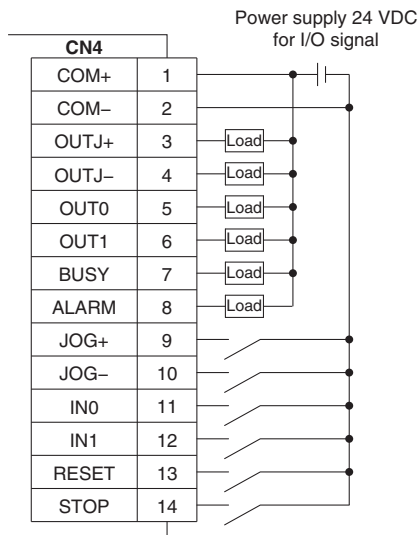

### ■ PNP

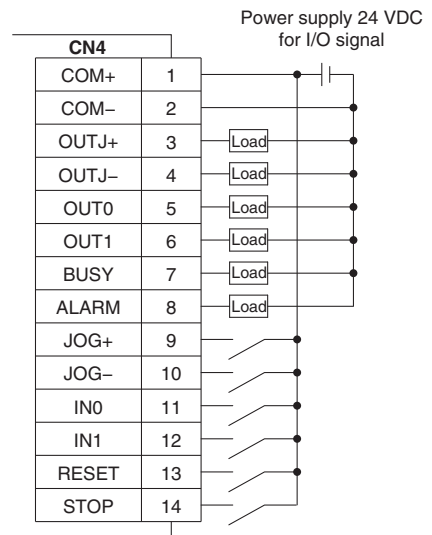

## Dimensions

### Screw mounting (LECP1□□-□□-XB182)

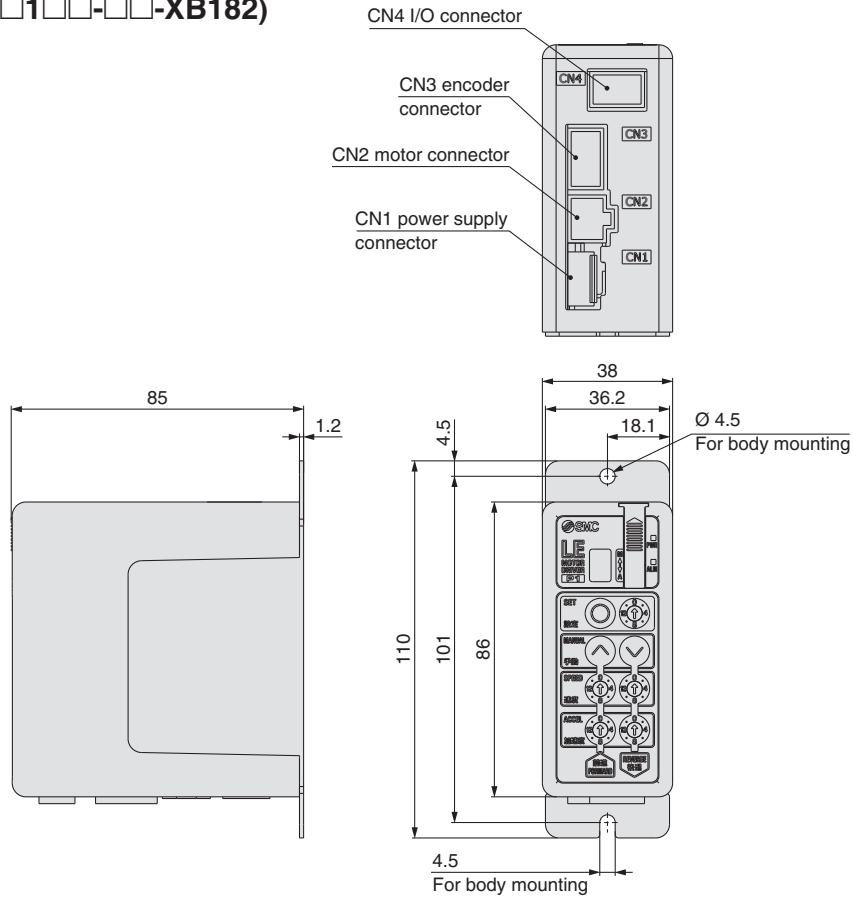

### DIN rail mounting (LECP1□□D-□□-XB182)

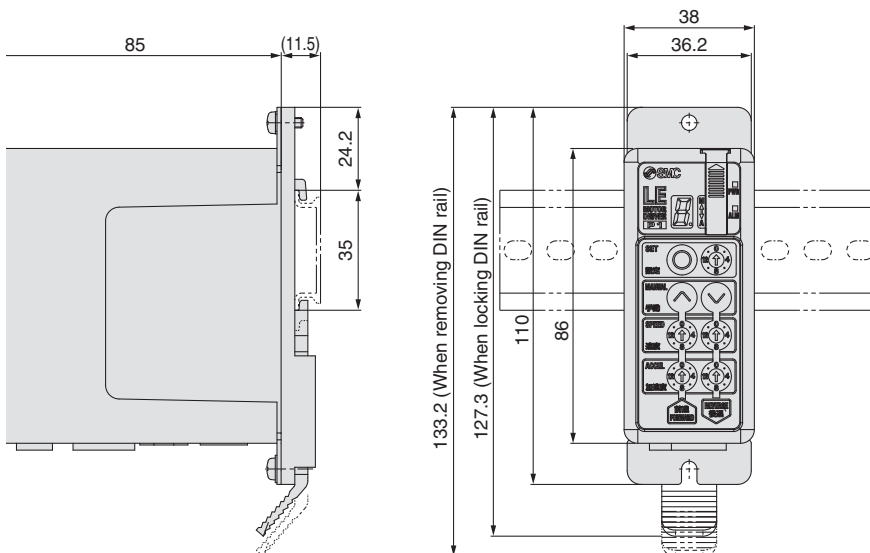

## ⚠ Caution

- ① **Jog operation is a function that is provided mainly for checking the operation of the machine when adjusting, inspecting, or performing maintenance on it.**  
While a jog operation is taking place, the alarm related to operation will not be detected. For this reason, it is not recommended to use this function during automatic operation of the machine.
- ② **If the moving part of the electric actuator is caused to collide with an object during a jog operation, the electric actuator is likely to break down.**  
Before using the actuator, carefully check that it will not collide with any objects.

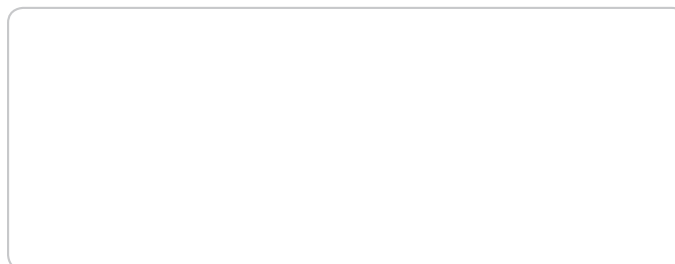

## SMC Corporation (Europe)

<b>Austria</b>	+43 (0)2262622800	www.smc.at	office@smc.at
<b>Belgium</b>	+32 (0)33551464	www.smc.be	info@smc.be
<b>Bulgaria</b>	+359 (0)2807670	www.smc.bg	office@smc.bg
<b>Croatia</b>	+385 (0)13707288	www.smc.hr	office@smc.hr
<b>Czech Republic</b>	+420 541424611	www.smc.cz	office@smc.cz
<b>Denmark</b>	+45 70252900	www.smc.dk.com	smc@smcdk.com
<b>Estonia</b>	+372 6510370	www.smc.pneumatics.ee	info@smcee.ee
<b>Finland</b>	+358 207513513	www.smc.fi	smc.fi@smc.fi
<b>France</b>	+33 (0)164761000	www.smc-france.fr	info@smc-france.fr
<b>Germany</b>	+49 (0)61034020	www.smc.de	info@smc.de
<b>Greece</b>	+30 210 2717265	www.smchellas.gr	sales@smchellas.gr
<b>Hungary</b>	+36 23513000	www.smc.hu	office@smc.hu
<b>Ireland</b>	+353 (0)14039000	www.smc.automation.ie	sales@smc.automation.ie
<b>Italy</b>	+39 03990691	www.smc.italy.it	mailbox@smc.italy.it
<b>Latvia</b>	+371 67817700	www.smc.lv	info@smc.lv

<b>Lithuania</b>	+370 5 2308118	www.smclt.lt	info@smclt.lt
<b>Netherlands</b>	+31 (0)205318888	www.smc.nl	info@smc.nl
<b>Norway</b>	+47 67129020	www.smc-norge.no	post@smc-norge.no
<b>Poland</b>	+48 222119600	www.smc.pl	office@smc.pl
<b>Portugal</b>	+351 214724500	www.smc.eu	apoioclientept@smc.smces.es
<b>Romania</b>	+40 213205111	www.smcromania.ro	smcromania@smcromania.ro
<b>Russia</b>	+7 8123036600	www.smc.eu	sales@smcru.com
<b>Slovakia</b>	+421 (0)413213212	www.smc.sk	office@smc.sk
<b>Slovenia</b>	+386 (0)73885412	www.smc.si	office@smc.si
<b>Spain</b>	+34 945184100	www.smc.eu	post@smc.smces.es
<b>Sweden</b>	+46 (0)86031200	www.smc.nu	smc@smc.nu
<b>Switzerland</b>	+41 (0)523963131	www.smc.ch	info@smc.ch
<b>Turkey</b>	+90 212 489 0 440	www.smc.pneumatik.com.tr	info@smc.pneumatik.com.tr
<b>UK</b>	+44 (0)845 121 5122	www.smc.uk	sales@smc.uk

SMC Corporation Akihabara UDX 15F, 4-14-1, Sotokanda, Chiyoda-ku, Tokyo 101-0021, JAPAN Phone: 03-5207-8249, Fax: 03-5298-5362