

Pilot Operated 2-Port Solenoid Valve



Max. operating pressure differential

4.0 MPa

Fluid Compressed air, Nitrogen, Argon, Oxygen*1

*1 When using oxygen, please refer to "Fluid Supply" on page 4.

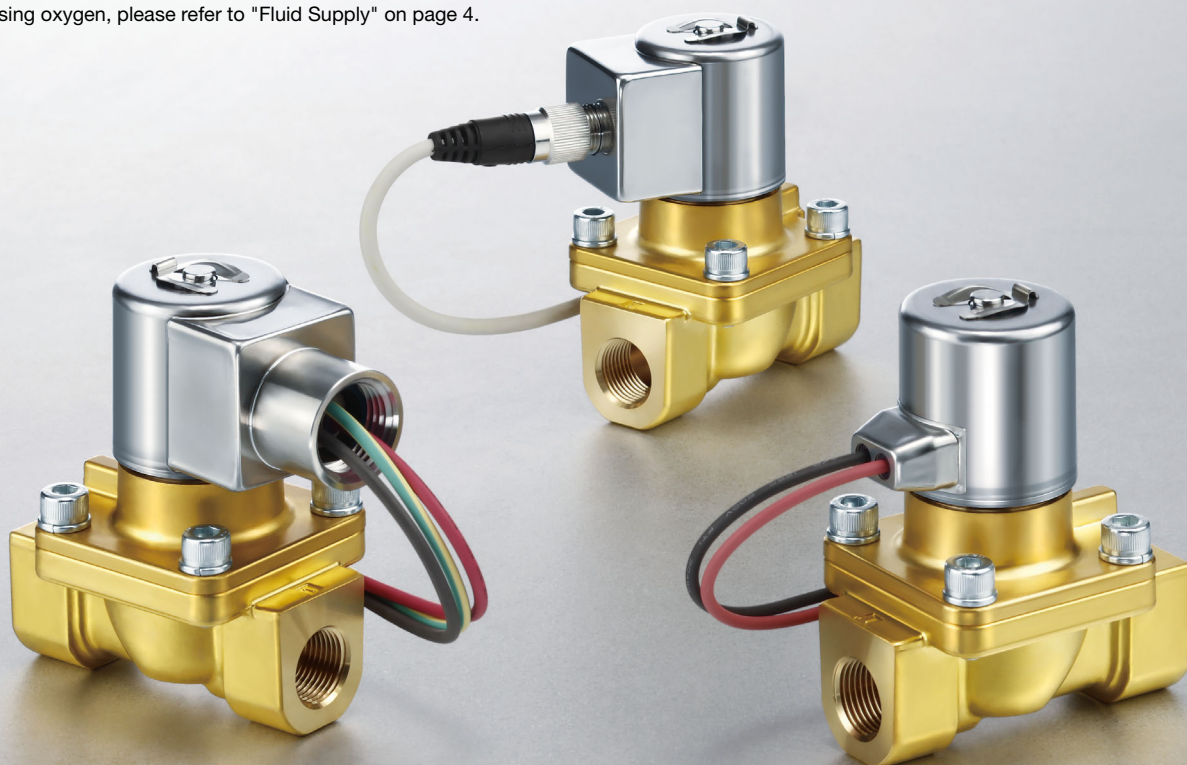

Low particle generation

Oil-free

IP67*2

*2 The DIN terminal is IP65.

Application Examples

Blow molding

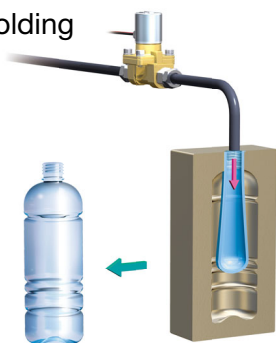

Laser processing machines

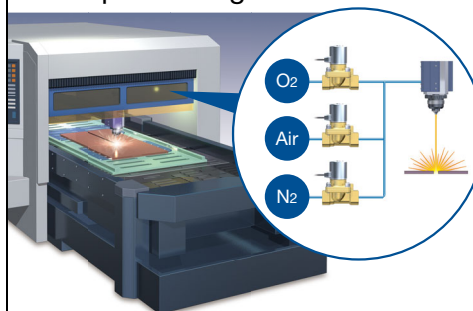

Nitrogen filling unit

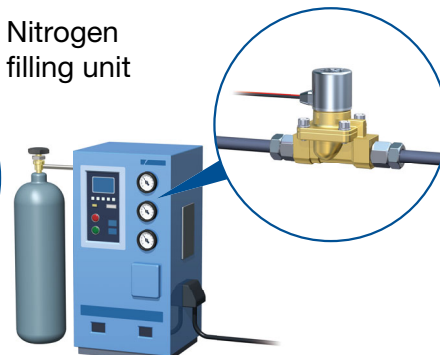

JSXH-X1



CAT.EUS70-65A-UK

Pilot Operated 2-Port Solenoid Valve JSXH-X1

Low particle generation

- No armature assembly collision
- Improved abrasion resistance
 - Increased rubber hardness (HNBR)
 - Poppet made from PUR
- No collision between metals due to bumpers

Power saving

Power consumption: 6 W

Stopper construction

- Metal noise reduced by the resin stopper
- Longer service life

Oil-free

Oil-free diaphragm construction

High flow rate and low pressure drop due to the optimised flow path through the body.

Easy maintenance

The coil can be replaced by simply removing the clip.

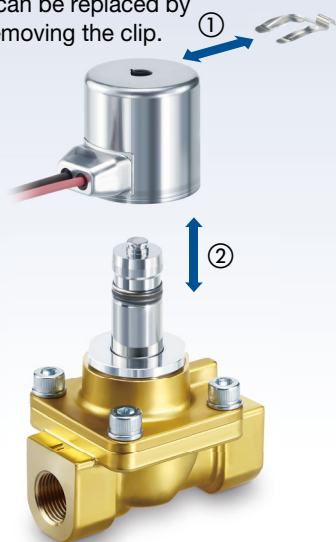

Improved environmental resistance

- Dustproof/waterproof IP67 structure
- With a stainless steel coil cover

Passed 1000 hours	Accelerated weathering test ISO 4892-3 (JIS K 7350-3) compliant
Passed 1000 hours	Ozone-proof exposure test ISO 1431 (JIS K 6259) compliant
Passed 960 hours	Combined cycle test ISO 14993 (JIS H 8502: 1999) compliant



* Please contact your local sales representative for more details.

Electrical Entry Variations

Grommet



Grommet with PCB

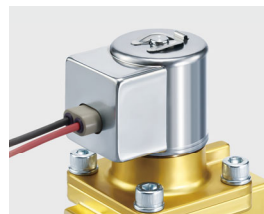

Conduit





DIN terminal



M12 connector



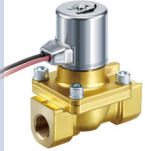



Specifications

Model	Port size	C [dm ³ /(s · bar)]	Orifice diameter [mmØ]	Fluid	Body material	Valve type	Seal material	Electrical entry	Standards
JSXH20 Series 	3/8	15	16	Compressed air Nitrogen Argon Oxygen*1	Brass	N.C.	PUR (Main valve) HNBR (Pilot valve)	Grommet DIN terminal Conduit M12 connector	 
	1/2	17.7							

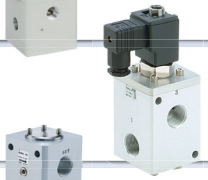
*1 When using oxygen, please refer to "Fluid Supply" on page 4.

Related Equipment

	Description	Max. operating pressure [MPa]	Series	Port size							
				1/4	1/2	3/8	3/4	1	1 1/4	1 1/2	
	High pressure electro-pneumatic regulator	5.0	ITVX			•					
		3.0	ITVH	•		•					
	Pilot operated 3-port solenoid valve	5.0	VCH410		•		•	•			
	Direct operated regulator (Relieving type)	Inlet pressure 6.0 Set pressure 0.5 to 5.0	VCHR30				•	•			
			VCHR40					•		•	
	Silencer	5.0 (Relief valve release pressure: 1.8 MPa)	VCHN3				•	•			
			VCHN4					•	•	•	
	Check valve	5.0	VCHC40				•	•			
	Pressure switch	5.0 (ISE76G) 10.0 (ISE77G) 16.0 (ISE78G) 50.0 (ISE79S)	ISE70□G/79S	•							

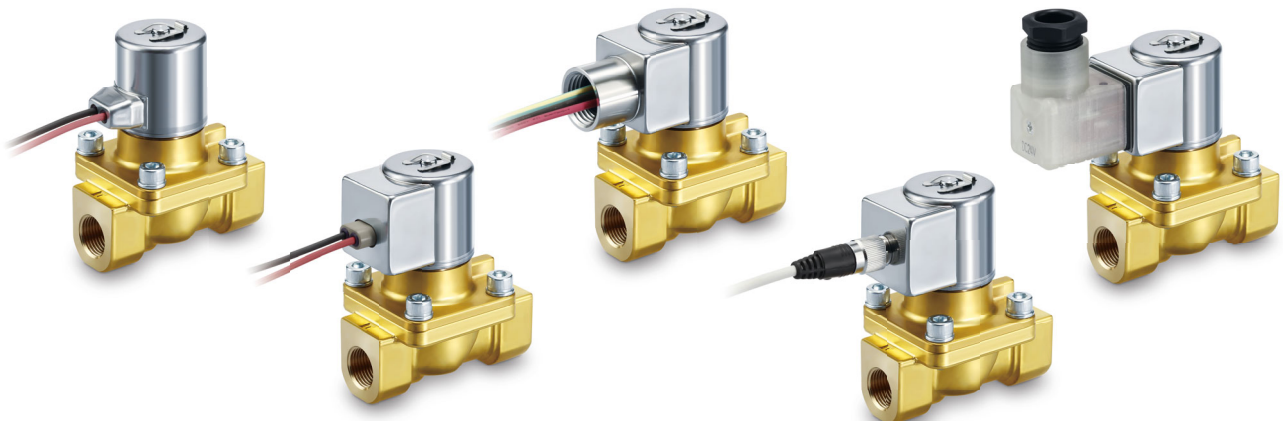

Pilot Operated 2-Port Solenoid Valve JSXH-X1



Differs depending on the voltage and electrical entry. For details, refer to table 10 below.



How to Order

JSXH21D-CH04F-5G-D-X1

1
2
3
4
5
6
7
8
9
10
11
12

1 Series

Symbol	Series
H	High-pressure/ Pilot operated

2 Size

Symbol	Size
2	20

3 Valve type

Symbol	Valve type
1	N.C. 2 (OUT) 1 (IN)

4 Main valve construction

Symbol	Main valve construction
D	Diaphragm

5 Body material

Symbol	Body material
C	Brass

6 Seal material

Symbol	Seal material	
	Main valve	Pilot valve
H	PUR	HNBR

7 Port size and orifice diameter

Symbol	Port size	Orifice diameter [mmØ]
03	3/8	16
04	1/2	

8 Thread type

Symbol	Thread type
R	Rc
N	NPT
F	G

9 Rated voltage

AC				DC	
Symbol	Rated voltage	Symbol	Rated voltage	Symbol	Rated voltage
1	100 VAC	7	240 VAC	5	24 VDC
2	200 VAC	8	48 VAC	6	12 VDC
3	120 (110) VAC	B	24 VAC		
4	220 VAC	J	230 VAC		

11 Option

Symbol	Option
-	None
D	Oil-free

12 Pressure type

Symbol	Specifications
X1	Operating pressure: 0.15 to 4.0 MPa Fluid: Air, Nitrogen, Oxygen, Argon

10 Electrical entry

Symbol	Electrical entry	CE/UKCA-compliant
G	Grommet*1	24 VDC
		12 VDC
GS	Grommet with PCB (With surge voltage suppressor)	100 VAC
		24 VDC
		12 VDC
		48 VAC
CS	Conduit (With surge voltage suppressor)	24 VAC
		All voltages
DS	DIN terminal (With surge voltage suppressor)	All voltages
		All voltages
DZ	DIN terminal with light (With surge voltage suppressor)	All voltages
		All voltages
DN	Without DIN connector (With surge voltage suppressor)	All voltages
		All voltages
WN	M12 connector/Without connector cable (With surge voltage suppressor)*2	All voltages
		All voltages

*1 DC voltage only

*2 A cable for the M 1 2 connector is not included with the product.

Specifications

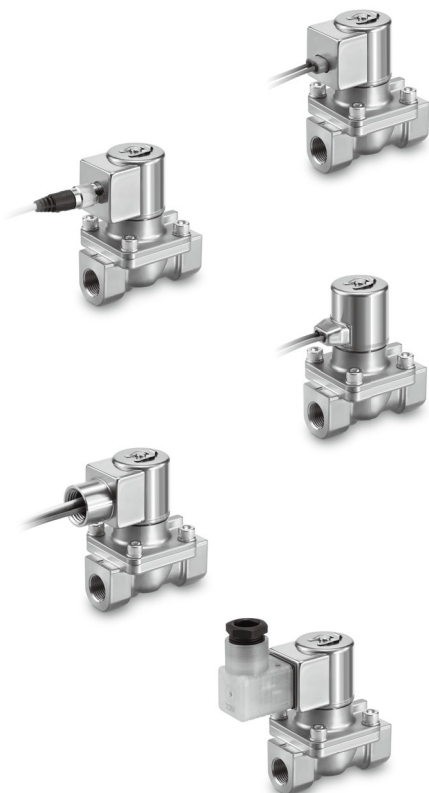

Size		20	
Valve construction		Pilot operated diaphragm	
Valve type		Normally closed (N.C.)	
Fluid		Compressed air, Nitrogen, Argon, Oxygen	
Orifice diameter		16 mmØ	
Port size		3/8"	1/2"
Flow rate characteristics*1	C [dm³/(s·bar)]	15	17.7
	b	0.36	0.22
	Cv	3.9	4.3
Max. operating pressure differential		4.0 MPa	
Min. operating pressure differential		0.15 MPa	
Fluid temperature		-10 to 50 °C	
Ambient temperature		-10 to 50 °C	
Leakage*1	Internal leakage	1 cm³/min or less	
	External leakage		
Thread type		G, Rc, NPT	
Max. system pressure		4.0 MPa	
Proof pressure		6.0 MPa	
Body material		Brass	
Degrees of protection		IP67 (IP65 for the DIN terminal)	
Seal material	Main valve	PUR	
	Pilot valve	HNBR	
Impact/Vibration resistance*2		150/30 m/s²	
Mounting orientation		Unrestricted	
Weight*6	Grommet	3/8"	1/2"
		713 g	671 g
Rated voltage	AC	24 V, 48 V, 100 V, 110 V, 120 V 200 V, 220 V, 230 V, 240 V	
	DC	12 V, 24 V	
Allowable voltage fluctuation		±10 % of the rated voltage	
Allowable leakage voltage	AC	5 % or less of the rated voltage	
	DC	2 % or less of the rated voltage	
Apparent power*3, *4	AC	8 VA	
Power consumption*3	DC	6 W	
Temperature rise*5	AC	70 °C	
	DC	65 °C	
Electrical entry		Grommet type, Conduit terminal DIN terminal, M12 connector	

*1 The value for air at a differential pressure of 0.15 MPa or higher and an ambient temperature of 20 °C

*2 Impact resistance: No malfunction occurred when tested with a drop tester in the axial direction and at a right angle to the main valve and armature in both an energised and a de-energised state, once in each condition. (Value in the initial state)
Vibration resistance: No malfunction occurred in a one-sweep test between 5 and 2000 Hz. The test was performed at both energised and de-energised states in the axial direction and at the right angles to the main valve and armature. (Value in the initial state)

*3 Power consumption/Apparent power: The value at an ambient temperature of 20 °C and when the rated voltage is applied (Variation: ±10 %)

*4 There is no difference in the frequency and the inrush and energised apparent power, since a rectifying circuit is used in the AC.

*5 Temperature rise: The value at an ambient temperature of 20 °C and when the rated voltage is applied.

Use this value as a reference as the actual value varies depending on the ambient environment

*6 The values are for the grommet type. Add 20 g for the grommet type with PCB, 70 g for the conduit type, 50 g for the DIN terminal type, and 15 g for the type without a DIN connector and the M12 connector type.

Fluid supply

⚠ Warning

- Compressed air, nitrogen, argon or oxygen can be used as a fluid.
- Do not use compressed air which includes chemicals, synthetic oils containing organic solvents, salt, or corrosive gases, etc., as this can cause damage or malfunction.
- If oxygen is used as the fluid, it can lead to serious and unforeseen risks. However, it is possible to manage and control the risk of hazards and economic loss. In order to use the product safely, it should only be handled by personnel with appropriate knowledge, with support from a suitably qualified specialist.
- Oxygen gas increases the susceptibility of substances to burning; Oxygen gas can be ignited by frictional heat and static electricity. If oxygen is ignited, the metal and seal materials burn. Therefore, flush the piping thoroughly and mount a suitable filter to prevent foreign matter such as metal powder and dust from entering the product.
- Take safety measures by installing safety devices (e.g. a circuit that stops the supply of oxygen gas) to prevent re and explosion in the event of failure, taking flameproof safety standards into consideration.

JSXH-X1

Dimensions

G: Grommet

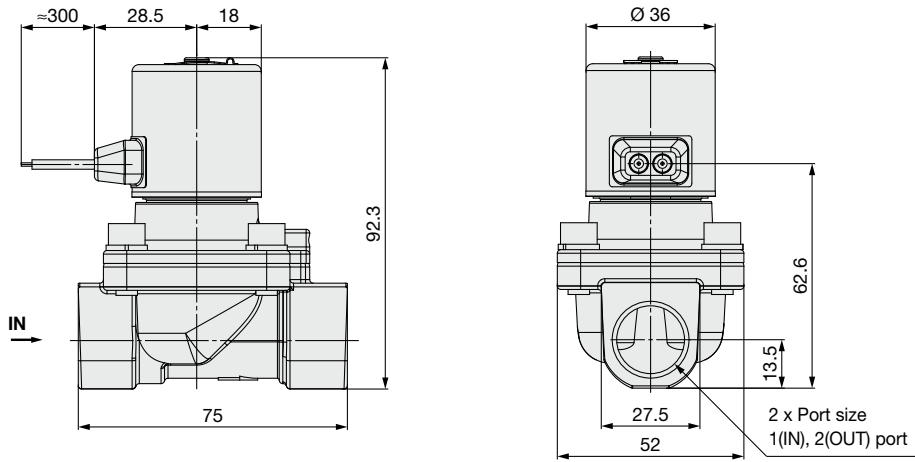

GS: Grommet with PCB

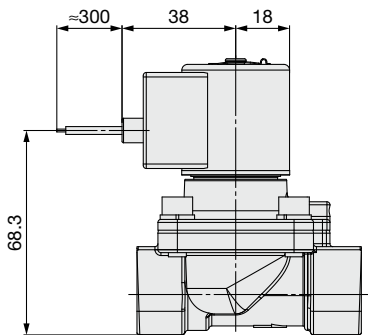

CS: Conduit

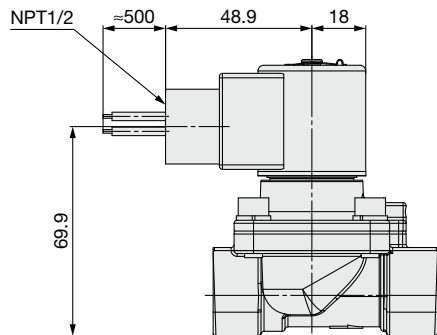

DS: DIN terminal

DZ: DIN terminal with light

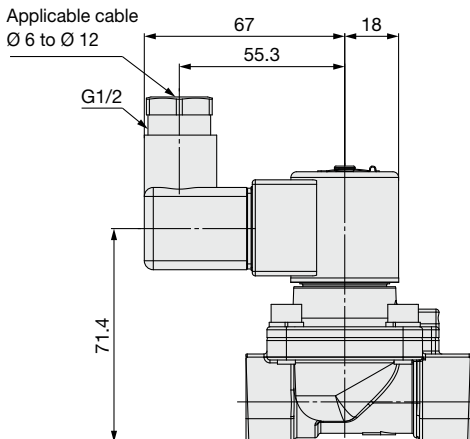

DN: Without DIN connector

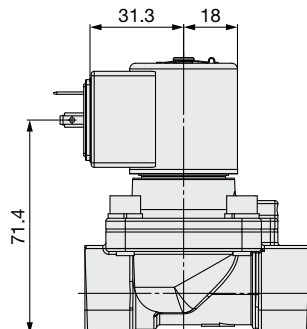

WN: M12 connector/

Without connector cable

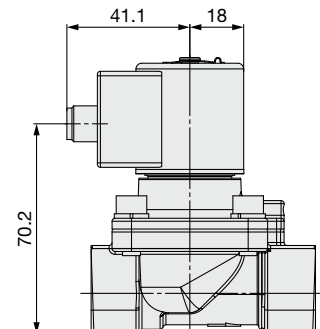

Safety Instructions

These safety instructions are intended to prevent hazardous situations and/or equipment damage. These instructions indicate the level of potential hazard with the labels of “Caution,” “Warning” or “Danger.” They are all important notes for safety and must be followed in addition to International Standards (ISO/IEC)¹⁾, and other safety regulations.

Danger:

Danger indicates a hazard with a high level of risk which, if not avoided, will result in death or serious injury.

Warning:

Warning indicates a hazard with a medium level of risk which, if not avoided, could result in death or serious injury.

Caution:

Caution indicates a hazard with a low level of risk which, if not avoided, could result in minor or moderate injury.

- 1) ISO 4414: Pneumatic fluid power – General rules and safety requirements for systems and their components.
ISO 4413: Hydraulic fluid power – General rules and safety requirements for systems and their components.
IEC 60204-1: Safety of machinery – Electrical equipment of machines. (Part 1: General requirements)
ISO 10218-1: Robots and robotic devices - Safety requirements for industrial robots - Part 1: Robots.
etc.

Warning

1. The compatibility of the product is the responsibility of the person who designs the equipment or decides its specifications.

Since the product specified here is used under various operating conditions, its compatibility with specific equipment must be decided by the person who designs the equipment or decides its specifications based on necessary analysis and test results. The expected performance and safety assurance of the equipment will be the responsibility of the person who has determined its compatibility with the product. This person should also continuously review all specifications of the product referring to its latest catalogue information, with a view to giving due consideration to any possibility of equipment failure when configuring the equipment.

2. Only personnel with appropriate training should operate machinery and equipment.

The product specified here may become unsafe if handled incorrectly. The assembly, operation and maintenance of machines or equipment including our products must be performed by an operator who is appropriately trained and experienced.

3. Do not service or attempt to remove product and machinery/equipment until safety is confirmed.

1. The inspection and maintenance of machinery/equipment should only be performed after measures to prevent falling or runaway of the driven objects have been confirmed.
2. When the product is to be removed, confirm that the safety measures as mentioned above are implemented and the power from any appropriate source is cut, and read and understand the specific product precautions of all relevant products carefully.
3. Before machinery/equipment is restarted, take measures to prevent unexpected operation and malfunction.

4. Our products cannot be used beyond their specifications. Our products are not developed, designed, and manufactured to be used under the following conditions or environments. Use under such conditions or environments is not covered.

1. Conditions and environments outside of the given specifications, or use outdoors or in a place exposed to direct sunlight.
2. Use for nuclear power, railways, aviation, space equipment, ships, vehicles, military application, equipment affecting human life, body, and property, fuel equipment, entertainment equipment, emergency shut-off circuits, press clutches, brake circuits, safety equipment, etc., and use for applications that do not conform to standard specifications such as catalogues and operation manuals.
3. Use for interlock circuits, except for use with double interlock such as installing a mechanical protection function in case of failure. Please periodically inspect the product to confirm that the product is operating properly.

Caution

We develop, design, and manufacture our products to be used for automatic control equipment, and provide them for peaceful use in manufacturing industries. Use in non-manufacturing industries is not covered.

Products we manufacture and sell cannot be used for the purpose of transactions or certification specified in the Measurement Act.

The new Measurement Act prohibits use of any unit other than SI units in Japan.

Limited warranty and Disclaimer/Compliance Requirements

The product used is subject to the following “Limited warranty and Disclaimer” and “Compliance Requirements”. Read and accept them before using the product.

Limited warranty and Disclaimer

1. The warranty period of the product is 1 year in service or 1.5 years after the product is delivered, whichever is first.²⁾ Also, the product may have specified durability, running distance or replacement parts. Please consult your nearest sales branch.
2. For any failure or damage reported within the warranty period which is clearly our responsibility, a replacement product or necessary parts will be provided. This limited warranty applies only to our product independently, and not to any other damage incurred due to the failure of the product.
3. Prior to using SMC products, please read and understand the warranty terms and disclaimers noted in the specified catalogue for the particular products.
- 2) Vacuum pads are excluded from this 1 year warranty.
A vacuum pad is a consumable part, so it is warranted for a year after it is delivered. Also, even within the warranty period, the wear of a product due to the use of the vacuum pad or failure due to the deterioration of rubber material are not covered by the limited warranty.

Compliance Requirements

1. The use of SMC products with production equipment for the manufacture of weapons of mass destruction (WMD) or any other weapon is strictly prohibited.
2. The exports of SMC products or technology from one country to another are governed by the relevant security laws and regulations of the countries involved in the transaction. Prior to the shipment of a SMC product to another country, assure that all local rules governing that export are known and followed.

Safety Instructions

Be sure to read “Handling Precautions for SMC Products” (M-E03-3) before using.

SMC Corporation (Europe)

Austria	+43 (0)2262622800	www.smc.at	office@smc.at
Belgium	+32 (0)33551464	www.smc.be	info@smc.be
Bulgaria	+359 (0)2807670	www.smc.bg	office@smc.bg
Croatia	+385 (0)13707288	www.smc.hr	office@smc.hr
Czech Republic	+420 541424611	www.smc.cz	office@smc.cz
Denmark	+45 70252900	www.smc.dk.com	smc@smcdk.com
Estonia	+372 651 0370	www.smcee.ee	info@smcee.ee
Finland	+358 207513513	www.smc.fi	smc.fi@smc.fi
France	+33 (0)164761000	www.smc-france.fr	supportclient@smc-france.fr
Germany	+49 (0)61034020	www.smc.de	info@smc.de
Greece	+30 210 2717265	www.smchellas.gr	sales@smchellas.gr
Hungary	+36 23513000	www.smc.hu	office@smc.hu
Ireland	+353 (0)14039000	www.smcautomation.ie	sales@smcautomation.ie
Italy	+39 03990691	www.smcitalia.it	mailbox@smcitalia.it
Latvia	+371 67817700	www.smc.lv	info@smc.lv

Lithuania	+370 5 2308118	www.smclt.lt	info@smclt.lt
Netherlands	+31 (0)205318888	www.smc.nl	info@smc.nl
Norway	+47 67129020	www.smc-norge.no	post@smc-norge.no
Poland	+48 222119600	www.smc.pl	sales@smc.pl
Portugal	+351 214724500	www.smc.eu	apoioclientept@smc.smces.es
Romania	+40 213205111	www.smcromania.ro	smcromania@smcromania.ro
Russia	+7 (812)3036600	www.smc.eu	sales@smcru.com
Slovakia	+421 (0)413213212	www.smc.sk	office@smc.sk
Slovenia	+386 (0)73885412	www.smc.si	office@smc.si
Spain	+34 945184100	www.smc.eu	post@smc.smces.es
Sweden	+46 (0)86031240	www.smc.nu	smc@smc.nu
Switzerland	+41 (0)523963131	www.smc.ch	info@smc.ch
Turkey	+90 212 489 0 440	www.smcturkey.com.tr	info@smcturkey.com.tr
UK	+44 (0)845 121 5122	www.smc.uk	sales@smc.uk

South Africa +27 10 900 1233 www.smcza.co.za zasales@smcza.co.za