

Compact Type

Speed Controller with Indicator

New

RoHS

1 to 50 mm/s **JAS-SML Series**

50 to 150 mm/s **JAS-SCL Series**

Height: Max. **20.8 mm** shorter

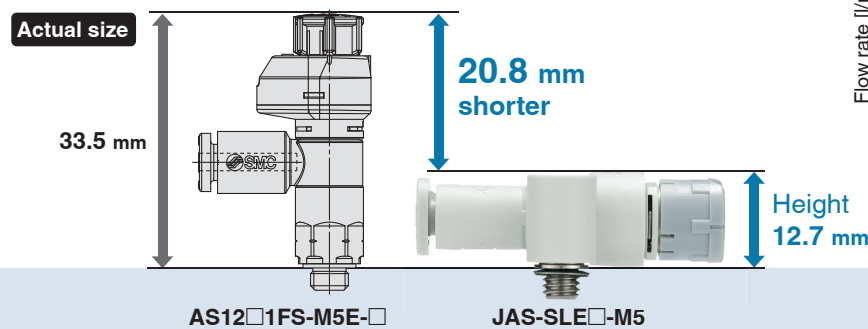

Improvement of resolution has made it possible to make fine adjustment.

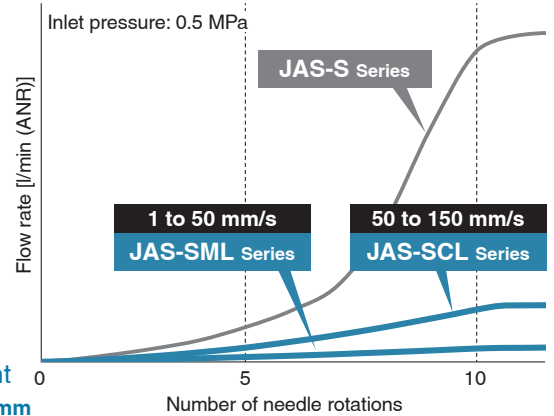

A vernier scale equipped at the upper part of the knob allows you to make a fine setting in units of quarter.

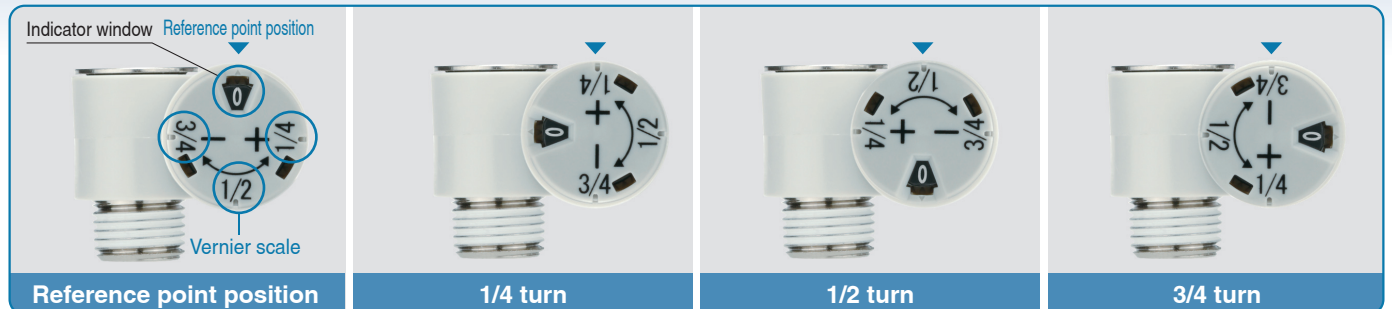

* For the JAS-SL□□-01S (The reference point position differs depending on the connection thread size. For details, refer to page 9.)

Flow rate can be controlled numerically with the indicator window.

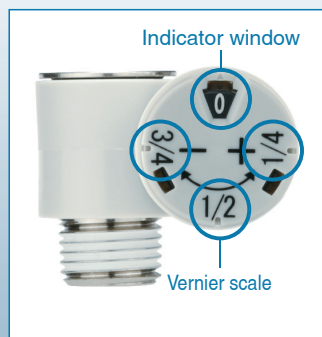

| Indicator window | Vernier scale |
|------------------|---------------|
| 0 | 1/4 |
| | 1/2 |
| | 3/4 |
| ⋮ | ⋮ |
| ⋮ | ⋮ |
| 10*1 | 1/4 |
| | 1/2 |
| | 3/4 |

*1 8 rotations for connection thread sizes M3, M5, and 10-32UNF

■ Due to the vernier indication, it is possible to configure fine settings in 1/4 increments.

- 32 divisions (Connection thread size: M3, M5, 10-32UNF)
- 40 divisions (Connection thread size: 1/8)

■ Reduces work-hours and setting mistakes



JAS-SML/SCL Series



CAT.EUS20-296A-UK

Compact Type Speed Controller with Indicator

Push-lock Type Elbow Type

1 to 50 mm/s

50 to 150 mm/s

RoHS

JAS-SML/SCL Series

1 to 50 mm/s

50 to 150 mm/s

Improvement of resolution has made it possible to make fine adjustment.

1 to 50 mm/s

JAS-SML Series

50 to 150 mm/s

JAS-SCL Series

How to Identify

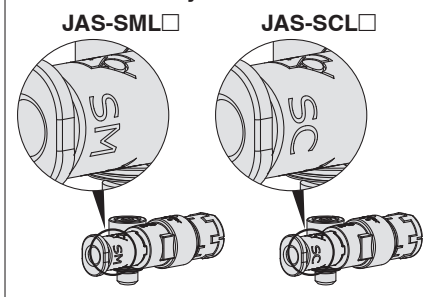

| Control type | Meter-out | Meter-in |
|--------------|-------------------------------------|-------------------------------------|
| Appearance | | |
| Symbol | Cylinder side Valve side | Cylinder side Valve side |

Caution

Be sure to read this before handling the products. Refer to the back cover for safety instructions. For flow control equipment precautions, refer to the "Handling Precautions for SMC Products" and the "Operation Manual" on the SMC website: <https://www.smc.eu>

Model

| Model | Port size | Seal method | Applicable tubing O.D. | | | | | |
|----------------|-----------|-------------|------------------------|---|---|-----------|-------|------|
| | | | Metric size | | | Inch size | | |
| | | | 3.2 | 4 | 6 | 1/8" | 5/32" | 1/4" |
| JAS-S□L□□□-M3 | M3 x 0.5 | Gasket seal | ● | ● | — | — | — | — |
| JAS-S□L□□□-M5 | M5 x 0.8 | | ● | ● | ● | — | — | — |
| JAS-S□L□□□-U10 | 10-32UNF | | — | — | — | ● | ● | — |
| JAS-S□L□□□-01 | R*1 | 1/8 | — | ● | ● | — | — | — |
| JAS-S□L□□□-N01 | NPT*1 | | | | | | | |
| JAS-S□L□□□-G01 | G | Face seal | — | ● | ● | — | — | — |

*1 "Without sealant" type can be selected as a standard option.

Specifications

| | |
|--------------------------------|---|
| Fluid | Air |
| Proof pressure | 1.05 MPa |
| Max. operating pressure | 0.7 MPa |
| Min. operating pressure | 0.05 MPa |
| Ambient and fluid temperatures | -5 to 60 °C (No freezing) |
| Applicable tubing material | Nylon, Soft nylon, Polyurethane, FEP, PFA |

* Use caution at the max. operating pressure when using soft nylon or polyurethane tubing. (Refer to the catalogue on <https://www.smc.eu> for details.)

Flow Rate and Sonic Conductance

JAS-SML Series

| Model | | JAS-SML□-M3 | JAS-SML□-M5 | JAS-SML□-01□ | |
|---|-----------------|--------------|---------------------|--------------|--------|
| Tubing O.D. | Metric size | ○ 3.2 ○ 4 | ○ 3.2 ○ 4 ○ 6 | ○ 4 | ○ 6 |
| | Inch size | — | ○ 1/8" ○ 5/32" | ○ 5/32" | ○ 1/4" |
| C values: Sonic conductance dm ³ /(s·bar) | Free flow | 0.2 | 0.3 | 0.7 | 0.9 |
| | Controlled flow | 0.01 | 0.01 | 0.03 | |
| b values: Critical pressure ratio | Free flow | 0.5 | 0.3 | 0.3 | |
| | Controlled flow | 0.4 | 0.4 | 0.4 | |
| Q [l/min(ANR)]*1 | Free flow | 59 | 75 | 178 | 229 |
| | Controlled flow | 3 | 3 | 8 | |

*1 These values have been calculated according to ISO 6358 and indicate the flow rate under standard conditions with an inlet pressure of 0.6 MPa (relative pressure) and a pressure drop of 0.1 MPa

JAS-SCL Series

| Model | | JAS-SCL□-M3 | JAS-SCL□-M5 | JAS-SCL□-01□ | |
|---|-----------------|--------------|---------------------|--------------|--------|
| Tubing O.D. | Metric size | ○ 3.2 ○ 4 | ○ 3.2 ○ 4 ○ 6 | ○ 4 | ○ 6 |
| | Inch size | — | ○ 1/8" ○ 5/32" | ○ 5/32" | ○ 1/4" |
| C values: Sonic conductance dm ³ /(s·bar) | Free flow | 0.2 | 0.3 | 0.7 | 0.9 |
| | Controlled flow | 0.05 | 0.05 | 0.1 | |
| b values: Critical pressure ratio | Free flow | 0.5 | 0.3 | 0.3 | |
| | Controlled flow | 0.4 | 0.4 | 0.4 | |
| Q [l/min(ANR)]*1 | Free flow | 59 | 76 | 178 | 229 |
| | Controlled flow | 14 | 14 | 27 | |

* 10-32UNF has the same specification as M5.

* C and b values are for controlled flow with the needle fully open and free flow with the needle fully closed.

*1 These values have been calculated according to ISO 6358 and indicate the flow rate under standard conditions with an inlet pressure of 0.6 MPa (relative pressure) and a pressure drop of 0.1 MPa

How to Order



JAS-S M L E A 04 - M5
JAS-S M L E A 04 - 01 S

With indicator

Control range

| | |
|----------|----------------|
| M | 1 to 50 mm/s |
| C | 50 to 150 mm/s |

Type

| | |
|----------|-------|
| L | Elbow |
|----------|-------|

Control type*1

| | |
|----------|-----------|
| E | Meter-out |
| S | Meter-in |

*1 Meter-out and meter-in types can be visually identified by the colour of the knob.
 Meter-out: Grey
 Meter-in: Light blue

Stud position

| | |
|----------|------------|
| A | Right side |
| B | Left side |

* Stud position left/right is defined with hexagonal socket visible and knob facing upward.

Stud position detail

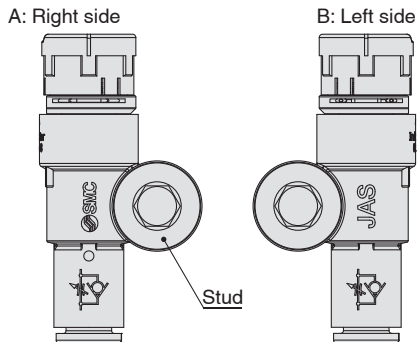

Connection thread size

| | |
|------------|----------|
| M3 | M3 x 0.5 |
| M5 | M5 x 0.8 |
| U10 | 10-32UNF |

Seal method

| | |
|----------|-----------------|
| - | Without sealant |
| S | With sealant |

* Face seal type is used for the G thread type.
 Select “-/Without sealant.”
 Example) JAS-SLEA04-G01

Connection thread size

| | |
|-----------|-----|
| 01 | 1/8 |
|-----------|-----|

Thread type

| | |
|----------|-----|
| - | R |
| N | NPT |
| G | G |

Applicable tubing O.D.*1

| Metric size | | Inch size | |
|-------------|---------|-----------|---------|
| 23 | ∅ 3.2*2 | 01 | ∅ 1/8" |
| 04 | ∅ 4 | 03 | ∅ 5/32" |
| 06 | ∅ 6 | 07 | ∅ 1/4" |

*1 For selecting applicable tubing O.D., refer to the “Model” on page 1.

*2 Use ∅ 1/8" tubing.

Flow Rate Characteristics

JAS-SML□-M3, M5

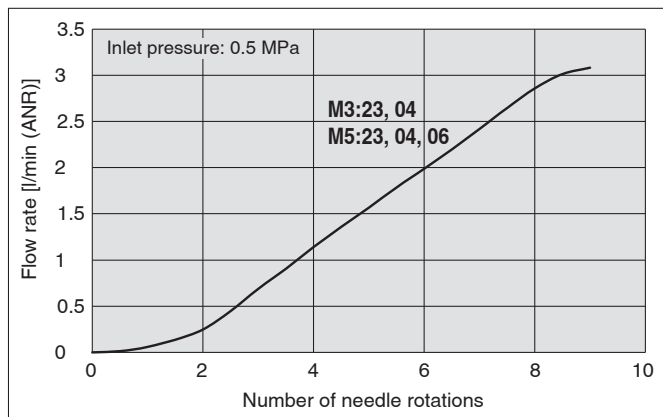

JAS-SML□-01□

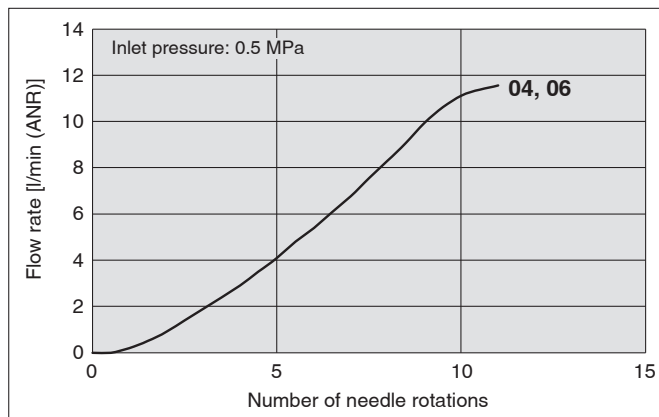

JAS-SCL□-M3, M5

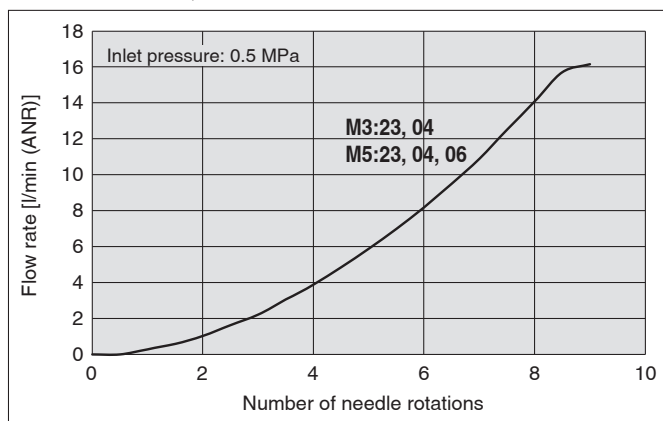

JAS-SCL□-01□

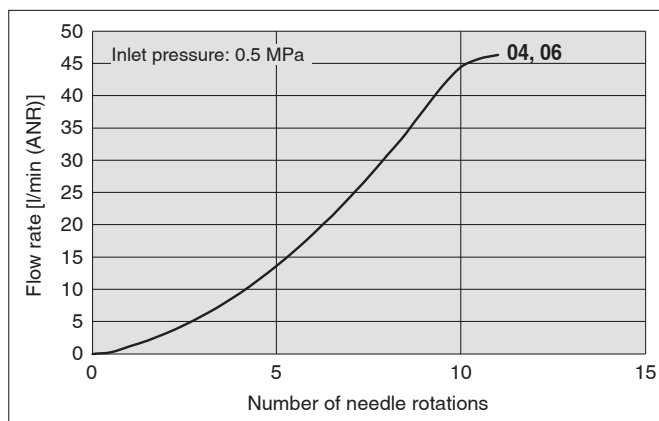

* The numbers above the flow rate characteristic curves in the charts show the applicable tubing outside diameter as defined by the product number.

Construction

Seal method: Gasket seal
For M3, M5, 10-32UNF

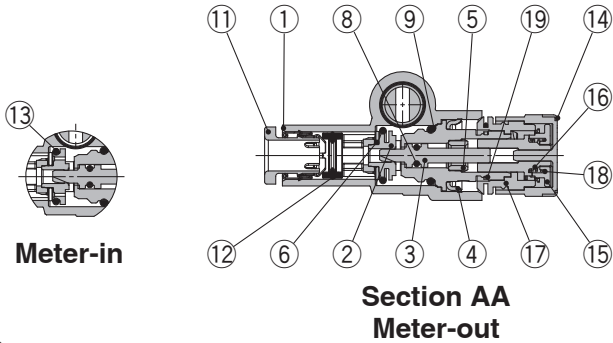

Seal method: Sealant
For R, NPT thread

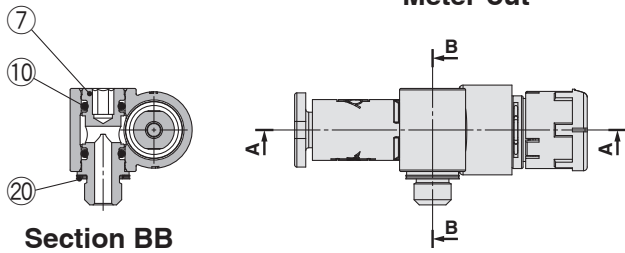
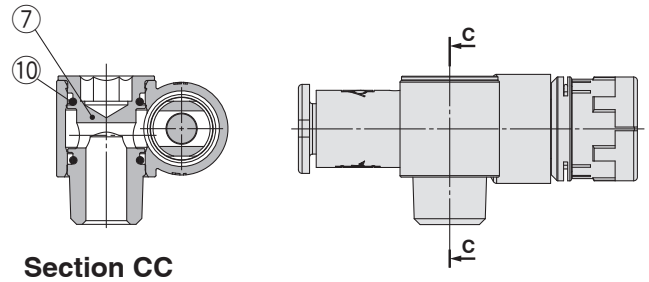

Seal method: Face seal
For G thread

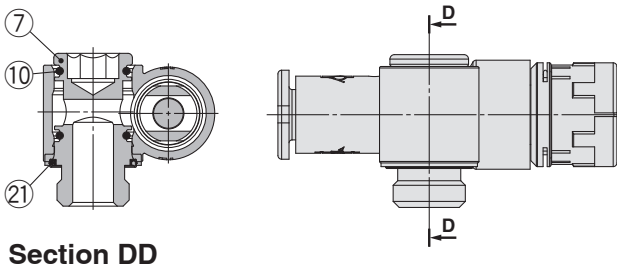

Component Parts

| No. | Description | Material | Note |
|-----|----------------|---------------------|----------------------------|
| 1 | Body A | PBT | |
| 2 | Body B | PBT | |
| 3 | Needle | PBT | |
| 4 | Stopper | Stainless steel | |
| 5 | Needle guide | Brass | Electroless nickel plating |
| 6 | Disk seal | HNBR | |
| 7 | Stud | Brass | Electroless nickel plating |
| 8 | O-ring | NBR | |
| 9 | O-ring | NBR | |
| 10 | O-ring | NBR | |
| 11 | Cassette | — | |
| 12 | Seal | NBR | |
| 13 | O-ring | NBR | |
| 14 | Knob | POM | |
| 15 | Indicator gear | POM | |
| 16 | Shaft | POM | |
| 17 | Spacer | PBT | |
| 18 | Spring | Stainless steel | |
| 19 | Clip | Stainless steel | |
| 20 | Gasket | NBR/Stainless steel | |
| 21 | Seal | NBR | |

1 to 50 mm/s 50 to 150 mm/s
JAS-SML/SCL Series

Dimensions

Seal method: Gasket seal
 For M3, M5, 10-32UNF

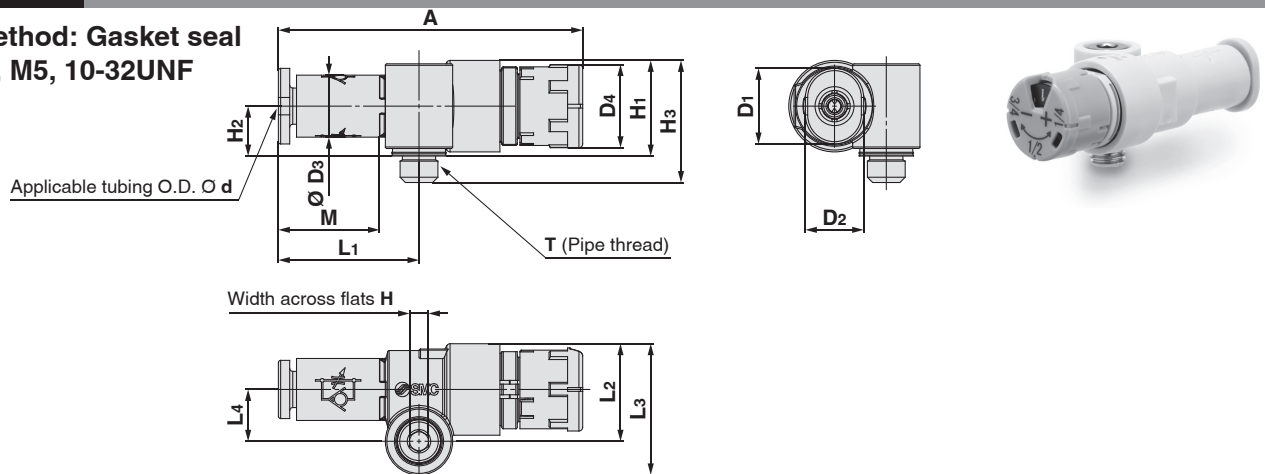

Metric Size

| Model | d | T | H | Release button | | D3 | D4 | A | | L1 | L2 | L3 | L4 | H1 | H2 | H3 | M | Weight [g] |
|----------------|-----|----------|-----|----------------|-----|------|------|----------|--------|------|------|------|-----|------|-----|------|------|------------|
| | | | | D1 | D2 | | | Unlocked | Locked | | | | | | | | | |
| JAS-S□L□□23-M3 | 3.2 | M3 x 0.5 | 2.5 | 9.5 | 6.7 | 7.2 | 11.0 | 40.6 | 39.5 | 18.6 | 12.9 | 17.4 | 6.9 | 12.7 | 6.6 | 16.2 | 13.3 | 4 |
| JAS-S□L□□04-M3 | 4 | | | 10 | 7.7 | 8.2 | | | | | | | | | | | | 4 |
| JAS-S□L□□06-M3 | 6 | | | 12 | 9.7 | 10.4 | | | | | | | | | | | | 5 |
| JAS-S□L□□23-M5 | 3.2 | M5 x 0.8 | 2.5 | 9.5 | 6.7 | 7.2 | 11.0 | 40.6 | 39.5 | 18.6 | 12.9 | 17.4 | 6.9 | 12.7 | 6.6 | 16.2 | 13.3 | 5 |
| JAS-S□L□□04-M5 | 4 | | | 10 | 7.7 | 8.2 | | | | | | | | | | | | 5 |
| JAS-S□L□□06-M5 | 6 | | | 12 | 9.7 | 10.4 | | | | | | | | | | | | 5 |

Inch Size

| Model | d | T | H | Release button | | D3 | D4 | A | | L1 | L2 | L3 | L4 | H1 | H2 | H3 | M | Weight [g] |
|-----------------|------|----------|-----|----------------|-----|-----|----|----------|--------|------|------|------|-----|------|-----|------|------|------------|
| | | | | D1 | D2 | | | Unlocked | Locked | | | | | | | | | |
| JAS-S□L□□01-U10 | 1/8 | 10/32UNF | 2.5 | 9.7 | 6.5 | 7.2 | 11 | 40.6 | 39.5 | 18.6 | 12.9 | 17.4 | 6.9 | 12.7 | 6.6 | 16.2 | 13.3 | 5 |
| JAS-S□L□□03-U10 | 5/32 | | | 10.0 | 7.7 | 8.2 | | | | | | | | | | | | 5 |

Seal method: Sealant
 For R, NPT thread

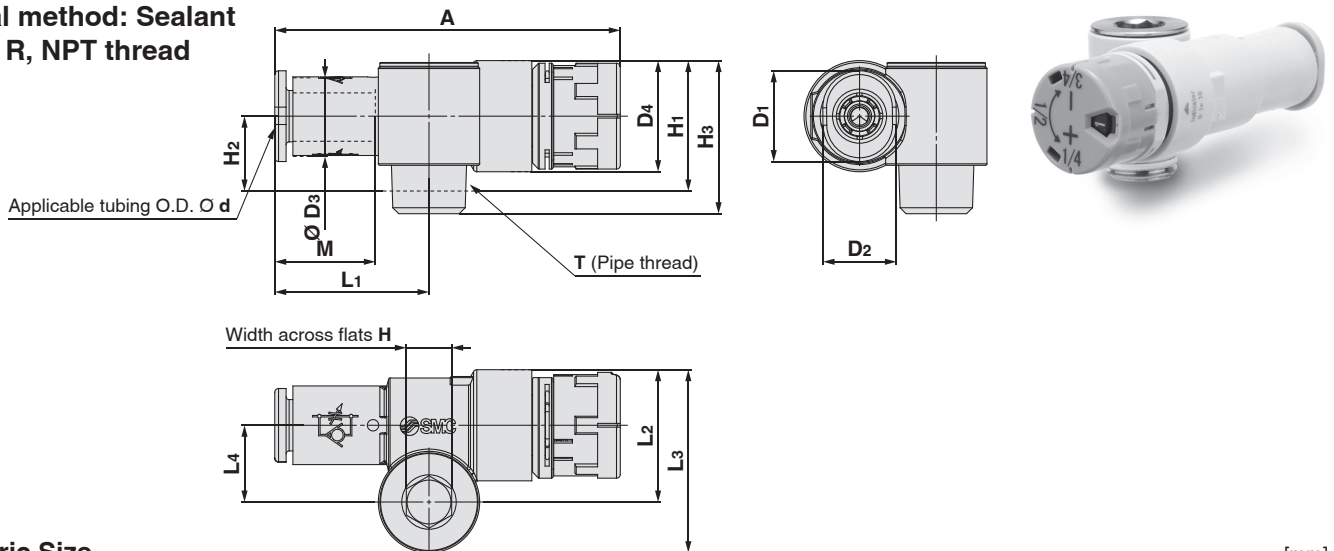

Metric Size

| Model | d | T (R, NPT) | H | Release button | | D3 | D4 | A | | L1 | L2 | L3 | L4 | H1 | H2 | H3 | M | Weight [g] |
|-------------------|---|------------|---|----------------|-----|------|----|----------|--------|------|------|------|------|------|-----|------|------|------------|
| | | | | D1 | D2 | | | Unlocked | Locked | | | | | | | | | |
| JAS-S□L□□04-01(S) | 4 | 1/8 | 6 | 10 | 7.7 | 8.2 | 14 | 47.4 | 45.9 | 20.4 | 17.5 | 24.2 | 10.2 | 17.1 | 9.7 | 20.3 | 13.3 | 11 |
| JAS-S□L□□06-01(S) | 6 | | | 12 | 9.7 | 10.4 | | | | | | | | | | | | 12 |

Inch Size

| Model | d | T (R, NPT) | H | Release button | | D3 | D4 | A | | L1 | L2 | L3 | L4 | H1 | H2 | H3 | M | Weight [g] |
|--------------------|------|------------|------|----------------|-----|------|----|----------|--------|------|------|------|------|------|-----|------|------|------------|
| | | | | D1 | D2 | | | Unlocked | Locked | | | | | | | | | |
| JAS-S□L□□03-N01(S) | 5/32 | 1/8 | 5.56 | 10 | 7.7 | 8.2 | 14 | 47.4 | 45.9 | 20.4 | 17.5 | 24.2 | 10.2 | 17.1 | 9.7 | 20.3 | 13.3 | 12 |
| JAS-S□L□□07-N01(S) | 1/4 | | | 10.9 | — | 11.2 | | | | | | | | | | | | 12 |

Dimensions

Seal method: Face seal
For G thread

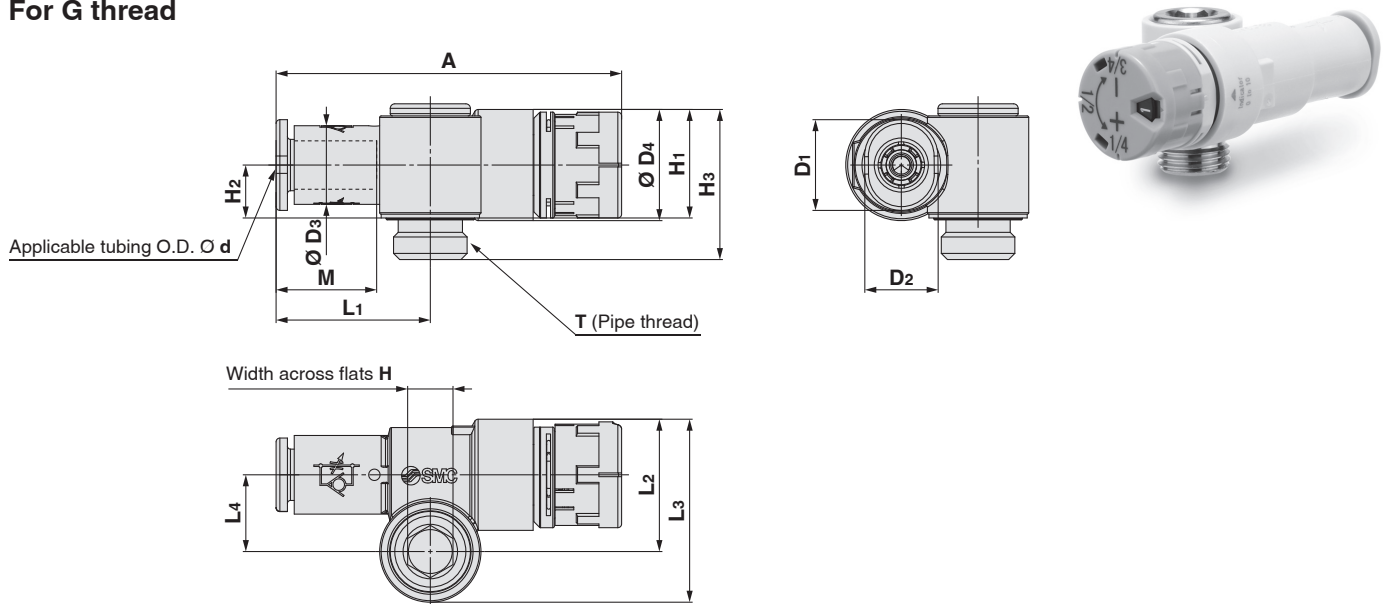

Metric Size

| Model | d | T | H | Release button | | D ₃ | D ₄ | A | | L ₁ | L ₂ | L ₃ | L ₄ | H ₁ | H ₂ | H ₃ | M | Weight [g] |
|-----------------|---|----|-----|-----------------|----------------|----------------|----------------|----------|--------|----------------|----------------|----------------|----------------|----------------|----------------|----------------|---|------------|
| | | | | D ₁ | D ₂ | | | Unlocked | Locked | | | | | | | | | |
| | | | | JAS-S□L□□04-G01 | 4 | | | 1/8 | 6 | | | | | | | | | |
| JAS-S□L□□06-G01 | 6 | 12 | 9.7 | 10.4 | | | | | | | | | | | | | | |

JAS-SML/SCL Series

Specific Product Precautions 1



Be sure to read this before handling the products. Refer to the back cover for safety instructions. For flow control equipment precautions, refer to the “Handling Precautions for SMC Products” and the “Operation Manual” on the SMC website: <https://www.smc.eu>

Design

Warning

1. Confirm the specifications.

Do not operate at pressures, temperatures, etc., beyond the range of specifications, as this can cause damage or malfunction. (Refer to the specifications.)

Please contact SMC when using a fluid other than compressed air (including vacuum).

We do not guarantee against any damage if the product is used outside of the specification range.

2. Products mentioned in this catalogue are not designed for use as stop valves with zero air leakage.

A certain amount of leakage is allowed in the products' specifications.

Tightening the needle forcibly to achieve zero leakage may result in damage of contact face stopper.

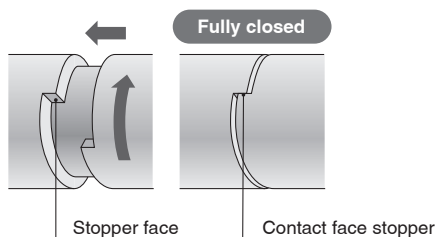

3. Do not disassemble the product or make any modifications, including additional machining.

Doing so may cause human injury and/or an accident.

4. The flow rate characteristics for each product are representative values.

The flow rate characteristics are characteristics of each individual product. Actual values may differ depending on the piping, circuitry, pressure conditions, etc.

There will be no flow rate from the fully closed position until 1 to 1.5 turns due to the product characteristic, but this is not the problem.

5. Sonic conductance (C) and critical pressure ratio (b) values for products are representative values.

For controlled flow direction values the needle is fully open. For free flow direction values the needle is fully closed.

6. Check if PTFE can be used in the application.

PTFE powder (Polytetrafluoroethylene resin) is included in the seal material of the male thread type piping taper thread. Confirm that the use of it will not cause any adverse effects on the system.

Please contact SMC if the Material Safety Data Sheet (MSDS) is required.

7. Speed controllers are designed to control the speed of the actuator.

Mounting

Warning

1. Operation manual

Install the product and operate it only after reading the operation manual carefully and understanding its contents. Also, keep the manual where it can be referred to as necessary.

2. Ensure sufficient space for maintenance activities.

When installing the products, allow access for maintenance and inspection.

3. Tighten threads with the proper tightening torque.

When installing the products, follow the listed torque specifications.

4. Screw the R screw into the Rc thread, the NPT screw into the NPT thread and the G screw into the G thread.

5. After pushing the knob down to lock, confirm that it is locked.

Confirm that the knob is locked by pushing the knob in after adjusting the cylinder speed. When the speed controller is unlocked, the set flow may change.

If the knob is pulled with force while the speed controller is unlocked, it may result in breakage. When it is unlocked, do not pull the knob out with force.

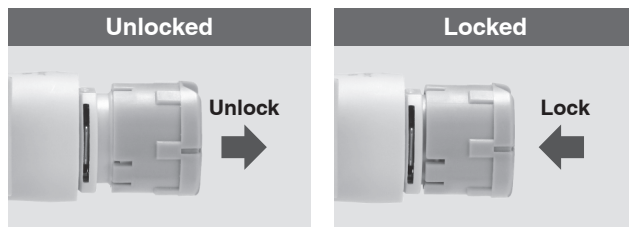

6. Check the degree of rotation of the needle valve.

As the needle valve has a stopper mechanism for max. open, it is not possible to rotate beyond the given limit. Forceful rotation of the needle beyond this point will cause damage, so check the table below for the number of rotations.

| Connection thread size | Number of needle rotations (reference) |
|------------------------|--|
| M3, M5, 10-32UNF | 8 |
| 1/8 | 10 |

7. Do not use tools, such as pliers, to rotate the knob.

This can cause the idle rotation of the knob or damage.

8. Confirm the air flow direction.

Mounting backward is dangerous because the speed adjustment needle will not work, and the actuator may lurch suddenly.

JAS-SML/SCL Series

Specific Product Precautions 2



Be sure to read this before handling the products. Refer to the back cover for safety instructions. For flow control equipment precautions, refer to the “Handling Precautions for SMC Products” and the “Operation Manual” on the SMC website: <https://www.smc.eu>

Mounting

Warning

9. Adjust the needle by opening the needle slowly after having closed it completely.

Loose needle valves may cause unexpected sudden actuator extension. When a needle valve is turned clockwise, it is closed and cylinder speed decreases. When a needle valve is turned counterclockwise, it is open and cylinder speed increases.

10. Do not turn the knob forcibly to prevent the scale from going outside the scale display range.

The scale may indicate a wrong value, possibly leading to a wrong setting. Wrong use example: While the scale indication range is 0 to 8, forcefully turning the knob in the opening direction from graduation 8 caused the scale to indicate 0.

| Connection thread size | Scale indication range |
|------------------------|------------------------|
| M5 | 0 to 8 graduations |
| 1/8 | 0 to 10 graduations |

The scale indication range is also printed on the product.

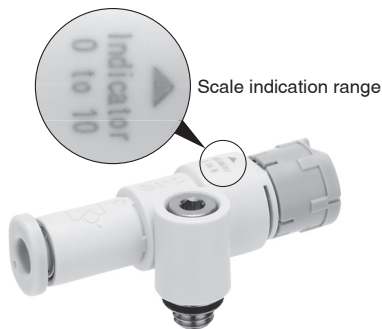

11. Slowly turn the knob in the opening direction or closing direction.

If quick reciprocal operations between two graduations like 0 → 1 → 0, which is not conducted in usual flow rate setting, are conducted, a scale malfunctioning may occur. (Guide for rotation speed: 1 [rev/sec] or below)

12. Do not apply excessive force or shock to the body or fittings with an impact tool.

This can cause damage or air leakage.

13. Refer to the Fittings and Tubing Precautions for handling One-touch fittings.

14. Insert the hexagon wrench into the end of the hexagonal hole of the stud when removing and mounting the speed controller.

Do not apply torque at other points, as the product may be damaged. Rotate body A manually for positioning after installation. Refer to the applicable dimension of the hexagon wrench.

| Connection thread size | Hexagon wrench (Nominal width across flats) | |
|------------------------|---|-----------|
| | Metric size | Inch size |
| M3, M5 | 2.5 | — |
| 10-32UNF | — | 3/32" |
| R1/8, G1/8 | 6 | — |
| NPT1/8 | — | 7/32" |

Warning

15. Do not use this product in the operating condition where moment loads will be constantly applied to body A.

Body A and the fitting section may be damaged.



16. This product has a stopper for the fully close needle position.

Excess torque may break the stopper. Table below shows the maximum allowable torque of the knob.

| Connection thread size | Max. allowable torque [N·m] |
|------------------------|-----------------------------|
| M3, M5, 10-32UNF | 0.04 |
| 01 | 0.07 |

Caution

1. M3, M5 and 10-32UNF

1) Tightening method

M3

First, tighten it by hand, then give it an additional 1 / 6 turn to 1/4 turn with a hexagon wrench.

Refer to the table below for reference.

| Connection thread size | Proper tightening torque [N·m] |
|------------------------|--------------------------------|
| M3 | 0.4 to 0.5 |

M5 and 10-32UNF

First, tighten it by hand, then give it an additional 1 / 6 turn to 1/4 turn with a hexagon wrench.

Refer to the table below for reference.

| Connection thread size | Proper tightening torque [N·m] |
|------------------------|--------------------------------|
| M5, 10-32UNF | 1 to 1.5 |

* Excessive tightening may damage the thread portion or deform the gasket and cause air leakage. If the screw is too shallowly screwed in, it may come loose or air may leak.

2) Female thread chamfer size

In compliance with ISO 1 6 0 3 0 Standards (air pressure fluid dynamics – connection – ports and stud ends), the chamfered thread sizes shown below are recommended.

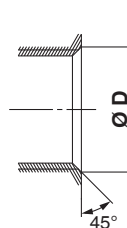

| Connection thread size | Chamfer dimension Ø D (Recommended value) |
|------------------------|---|
| M3 | 3.1 to 3.4 |
| M5 | 5.1 to 5.4 |
| 10-32UNF | 5.0 to 5.3 |

JAS-SML/SCL Series

Specific Product Precautions 3



Be sure to read this before handling the products. Refer to the back cover for safety instructions. For flow control equipment precautions, refer to the "Handling Precautions for SMC Products" and the "Operation Manual" on the SMC website: <https://www.smc.eu>

Mounting

Caution

2. R, NPT and G Thread

1) Tightening method

When tightening the stud, insert an appropriate hexagon wrench to the hexagonal hole after tightening it by hand. Refer to the table below for reference.

| Connection thread size | Proper tightening torque [N·m] |
|------------------------|--------------------------------|
| 1/8 | 3 to 5 |

2) Female thread chamfer size

By chamfering as shown in the following table, machining of threads is easier and effective for burr prevention.

| Connection thread size | Chamfer dimension ϕD (Recommended value) | | |
|------------------------|--|--------------|-------------|
| | Rc | NPT | G Face seal |
| 1/8 | 10.2 to 10.4 | 10.5 to 10.7 | 9.8 to 10.2 |

* G thread (face seal) complies with ISO 16030-2001.

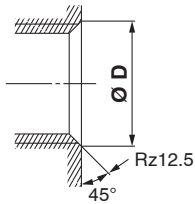

3) Do not turn the product by holding the indicator part.

When a torque is applied to the handle or spacer with the handle lock engaged, an erroneous operation or breakage of the scale may occur. Perform mounting by hooking a wrench to the hexagonal part.

Reference Point

The reference point (scale zero point) of this product differs depending on the product number.

Refer to the following for details.

Connection thread size: M3, M5, 10-32UNF

Reference point position

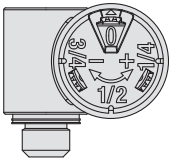

A: Right side

Reference point position

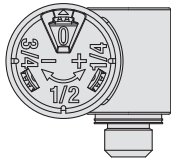

B: Left side

Connection thread size: 1/8

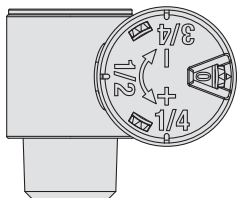

A: Right side

Reference point position

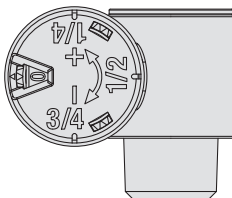

B: Left side

Piping Threads with Sealant

Caution

- If the fitting is tightened with excessive torque, a large amount of sealant will seep out. Remove the excess sealant.
- Insufficient tightening may loosen the threads or cause air leakage.
- For reuse
 - Normally, fittings with a sealant can be reused up to 2 to 3 times.
 - To prevent air leakage through the sealant, remove any loose sealant stuck to the fitting by blowing air over the threaded portion.
 - If the sealant no longer provides effective sealing, wind sealant tape over the sealant before reusing. Do not use any form other than the tape type of sealant.
- Once the fitting has been tightened, backing it out to its original position often causes the sealant to become defective. Air leakage will occur.

Piping

Caution

1. Refer to the Fittings and Tubing Precautions for handling One-touch fittings.

2. Preparation before piping

Before piping is connected, it should be thoroughly blown out with air (flushing) or washed to remove chips, cutting oil, and other debris from inside the pipe.

Piping Threads with Sealant

1. Winding of sealant tape

When screwing piping or fittings into ports, ensure that chips from the pipe threads or sealing material do not enter the piping. Also, if sealant tape is used, leave 1 thread ridge exposed at the end of the threads.

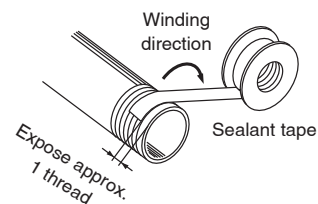

Safety Instructions

These safety instructions are intended to prevent hazardous situations and/or equipment damage. These instructions indicate the level of potential hazard with the labels of “Caution,” “Warning” or “Danger.” They are all important notes for safety and must be followed in addition to International Standards (ISO/IEC)¹⁾, and other safety regulations.

Caution:

Caution indicates a hazard with a low level of risk which, if not avoided, could result in minor or moderate injury.

Warning:

Warning indicates a hazard with a medium level of risk which, if not avoided, could result in death or serious injury.

Danger:

Danger indicates a hazard with a high level of risk which, if not avoided, will result in death or serious injury.

- 1) ISO 4414: Pneumatic fluid power – General rules relating to systems.
ISO 4413: Hydraulic fluid power – General rules relating to systems.
IEC 60204-1: Safety of machinery – Electrical equipment of machines.
(Part 1: General requirements)
ISO 10218-1: Manipulating industrial robots - Safety.
etc.

Warning

1. The compatibility of the product is the responsibility of the person who designs the equipment or decides its specifications.

Since the product specified here is used under various operating conditions, its compatibility with specific equipment must be decided by the person who designs the equipment or decides its specifications based on necessary analysis and test results. The expected performance and safety assurance of the equipment will be the responsibility of the person who has determined its compatibility with the product. This person should also continuously review all specifications of the product referring to its latest catalogue information, with a view to giving due consideration to any possibility of equipment failure when configuring the equipment.

2. Only personnel with appropriate training should operate machinery and equipment.

The product specified here may become unsafe if handled incorrectly. The assembly, operation and maintenance of machines or equipment including our products must be performed by an operator who is appropriately trained and experienced.

3. Do not service or attempt to remove product and machinery/equipment until safety is confirmed.

1. The inspection and maintenance of machinery/equipment should only be performed after measures to prevent falling or runaway of the driven objects have been confirmed.
2. When the product is to be removed, confirm that the safety measures as mentioned above are implemented and the power from any appropriate source is cut, and read and understand the specific product precautions of all relevant products carefully.
3. Before machinery/equipment is restarted, take measures to prevent unexpected operation and malfunction.

4. Contact SMC beforehand and take special consideration of safety measures if the product is to be used in any of the following conditions.

1. Conditions and environments outside of the given specifications, or use outdoors or in a place exposed to direct sunlight.
2. Installation on equipment in conjunction with atomic energy, railways, air navigation, space, shipping, vehicles, military, medical treatment, combustion and recreation, or equipment in contact with food and beverages, emergency stop circuits, clutch and brake circuits in press applications, safety equipment or other applications unsuitable for the standard specifications described in the product catalogue.
3. An application which could have negative effects on people, property, or animals requiring special safety analysis.
4. Use in an interlock circuit, which requires the provision of double interlock for possible failure by using a mechanical protective function, and periodical checks to confirm proper operation.

Caution

1. The product is provided for use in manufacturing industries.

The product herein described is basically provided for peaceful use in manufacturing industries.

If considering using the product in other industries, consult SMC beforehand and exchange specifications or a contract if necessary. If anything is unclear, contact your nearest sales branch.

Limited warranty and Disclaimer/Compliance Requirements

The product used is subject to the following “Limited warranty and Disclaimer” and “Compliance Requirements”. Read and accept them before using the product.

Limited warranty and Disclaimer

1. The warranty period of the product is 1 year in service or 1.5 years after the product is delivered, whichever is first.²⁾ Also, the product may have specified durability, running distance or replacement parts. Please consult your nearest sales branch.
 2. For any failure or damage reported within the warranty period which is clearly our responsibility, a replacement product or necessary parts will be provided. This limited warranty applies only to our product independently, and not to any other damage incurred due to the failure of the product.
 3. Prior to using SMC products, please read and understand the warranty terms and disclaimers noted in the specified catalogue for the particular products.
- 2) Vacuum pads are excluded from this 1 year warranty.
A vacuum pad is a consumable part, so it is warranted for a year after it is delivered. Also, even within the warranty period, the wear of a product due to the use of the vacuum pad or failure due to the deterioration of rubber material are not covered by the limited warranty.

Compliance Requirements

1. The use of SMC products with production equipment for the manufacture of weapons of mass destruction (WMD) or any other weapon is strictly prohibited.
2. The exports of SMC products or technology from one country to another are governed by the relevant security laws and regulations of the countries involved in the transaction. Prior to the shipment of a SMC product to another country, assure that all local rules governing that export are known and followed.

Caution

SMC products are not intended for use as instruments for legal metrology.

Measurement instruments that SMC manufactures or sells have not been qualified by type approval tests relevant to the metrology (measurement) laws of each country. Therefore, SMC products cannot be used for business or certification ordained by the metrology (measurement) laws of each country.

Safety Instructions

Be sure to read “Handling Precautions for SMC Products” (M-E03-3) before using.

SMC Corporation (Europe)

| | | | |
|-----------------------|-------------------|----------------------|-----------------------------|
| Austria | +43 (0)2262622800 | www.smc.at | office@smc.at |
| Belgium | +32 (0)33551464 | www.smc.be | info@smc.be |
| Bulgaria | +359 (0)2807670 | www.smc.bg | office@smc.bg |
| Croatia | +385 (0)13707288 | www.smc.hr | office@smc.hr |
| Czech Republic | +420 541424611 | www.smc.cz | office@smc.cz |
| Denmark | +45 70252900 | www.smc.dk.com | smc@smcdk.com |
| Estonia | +372 651 0370 | www.smcee.ee | info@smcee.ee |
| Finland | +358 207513513 | www.smc.fi | smcfi@smc.fi |
| France | +33 (0)164761000 | www.smc-france.fr | supportclient@smc-france.fr |
| Germany | +49 (0)61034020 | www.smc.de | info@smc.de |
| Greece | +30 210 2717265 | www.smchellas.gr | sales@smchellas.gr |
| Hungary | +36 23513000 | www.smc.hu | office@smc.hu |
| Ireland | +353 (0)14039000 | www.smcautomation.ie | sales@smcautomation.ie |
| Italy | +39 03990691 | www.smcitalia.it | mailbox@smcitalia.it |
| Latvia | +371 67817700 | www.smc.lv | info@smc.lv |

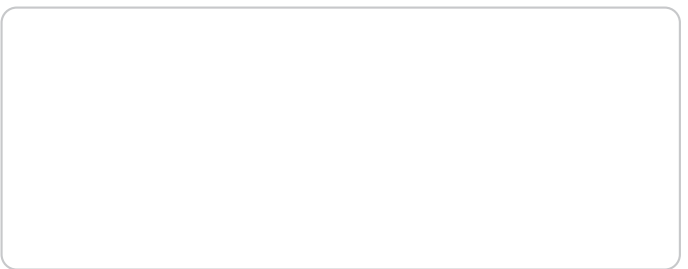

| | | | |
|---------------------|---------------------|----------------------|-----------------------------|
| Lithuania | +370 5 2308118 | www.smclt.lt | info@smclt.lt |
| Netherlands | +31 (0)205318888 | www.smc.nl | info@smc.nl |
| Norway | +47 67129020 | www.smc-norge.no | post@smc-norge.no |
| Poland | +48 222119600 | www.smc.pl | office@smc.pl |
| Portugal | +351 214724500 | www.smc.eu | apoioclientept@smc.smces.es |
| Romania | +40 213205111 | www.smcromania.ro | smcromania@smcromania.ro |
| Russia | +7 (812)3036600 | www.smc.eu | sales@smcru.com |
| Slovakia | +421 (0)413213212 | www.smc.sk | office@smc.sk |
| Slovenia | +386 (0)73885412 | www.smc.si | office@smc.si |
| Spain | +34 945184100 | www.smc.eu | post@smc.smces.es |
| Sweden | +46 (0)86031240 | www.smc.nu | smc@smc.nu |
| Switzerland | +41 (0)523963131 | www.smc.ch | info@smc.ch |
| Turkey | +90 212 489 0 440 | www.smcturkey.com.tr | satis@smcturkey.com.tr |
| UK | +44 (0)845 121 5122 | www.smc.uk | sales@smc.uk |
| South Africa | +27 10 900 1233 | www.smcza.co.za | zasales@smcza.co.za |