

Refrigerated Air Dryer

CE

For Use in Europe, Asia and Oceania

Applicable for the high-temperature environments

Ambient temperature: Max. 45 °C

Inlet air temperature: Max. 65 °C

Air flow capacity

* IDFA90-23, Dew point of 3 °C

810 m³/h

(23 % increase compared to the existing model)

Power supply voltage

Single-phase 230 VAC (50 Hz)



New

An option with cool compressed air output has been added. An option with Chinese labels and a Chinese operation manual has been added. A bypass piping set has been added as an optional accessory.

IDFA Series

SMC

CAT.EUS30-20Bb-UK

Applicable for the high-temperature environments

	IDFA Series	Existing model IDFA Series
Ambient temperature	Max. 45 °C	Max. 40 °C
Inlet air temperature	Max. 65 °C	Max. 50 °C

Increased air flow capacity

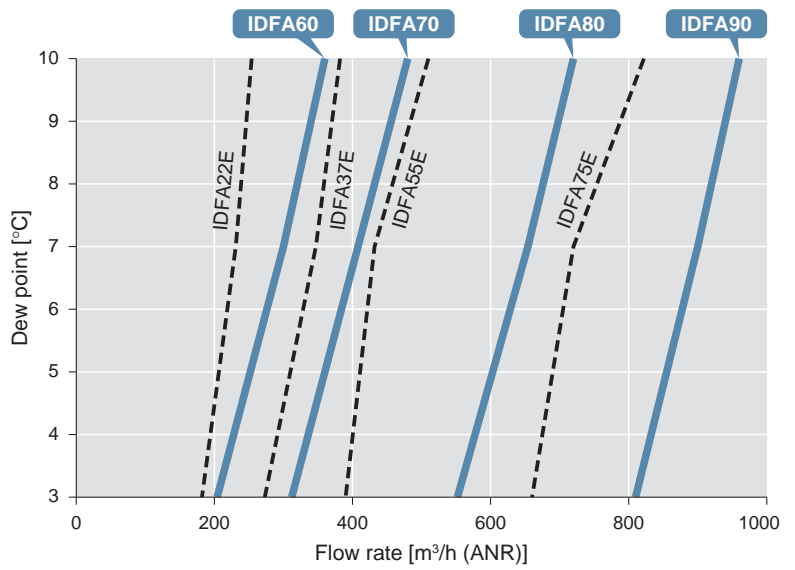

New stainless steel heat exchanger helps reduce the load of the compressor

Easier maintenance

- The temperature range for normal operating conditions is indicated by the green zone.

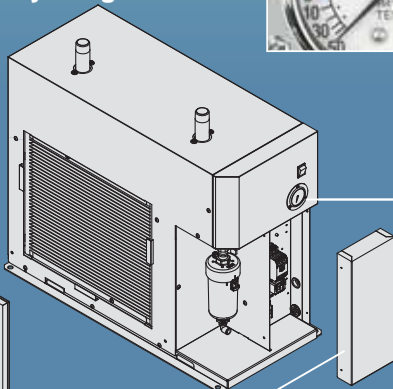
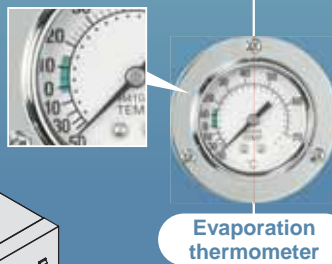

- Dustproof filter provided as a standard accessory

Prevents clogging of the condenser
Can be installed without tools

- All electrical components are located in the front of the product.

The electrical components can be checked by removing the front panel.



Series Variations

Model	Rated inlet condition	Rated ambient temperature	Air flow capacity [m³/h]			Port size
			Dew point 3 °C	Dew point 7 °C	Dew point 10 °C	
IDFA60	35 °C 0.7 MPa	25 °C	204	300	360	R1
IDFA70			312	408	480	R1 1/2
IDFA80			552	654	720	R2
IDFA90			810	900	960	

Options

p. 9

- New** Cool compressed air output
- Anti-corrosive treatment for copper tube
- New** With Chinese labels and a Chinese operation manual
- With a heavy-duty auto drain
- With an earth leakage breaker
- With a terminal block for operating, error, and remote operation signals
- With a timer controlled solenoid valve type auto drain

Optional accessories

p. 8

- Foundation bolt set
- Piping adapter
- New** Bypass piping set



Auto Drain Valve Longer life, Higher resistance to foreign matter

Non-sliding part reduces the catching of foreign matter
Diaphragm type
Poppet type

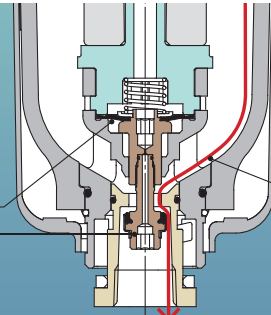

Shape prevents condensate accumulation
Condensate and foreign matter are discharged completely.

Easier maintenance

- One-touch mounting and removal of the bowl is possible without using any tools.

Release the lock by sliding the lock button down while holding the body. Then, rotate the bowl guard and pull down for removal.



Transparent bowl guard

- Allows you to visually check the condensate condition in the bowl
- Improved environmental durability due to 2-layer construction



Drain tube holder (Accessory)

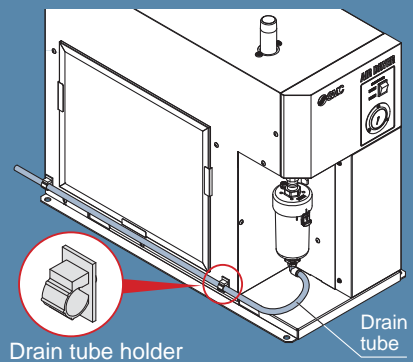

Protect Pneumatic Equipment from Moisture!

An air dryer removes the vapour from the moist compressed air delivered by the compressor and prevents it from causing the pneumatic equipment to fail.

Effects of moisture on equipment

- Malfunctioning of valves and actuators caused by dripping grease
- Generation of water droplets
- Decomposition of auto drain caused by rusting inside pipes

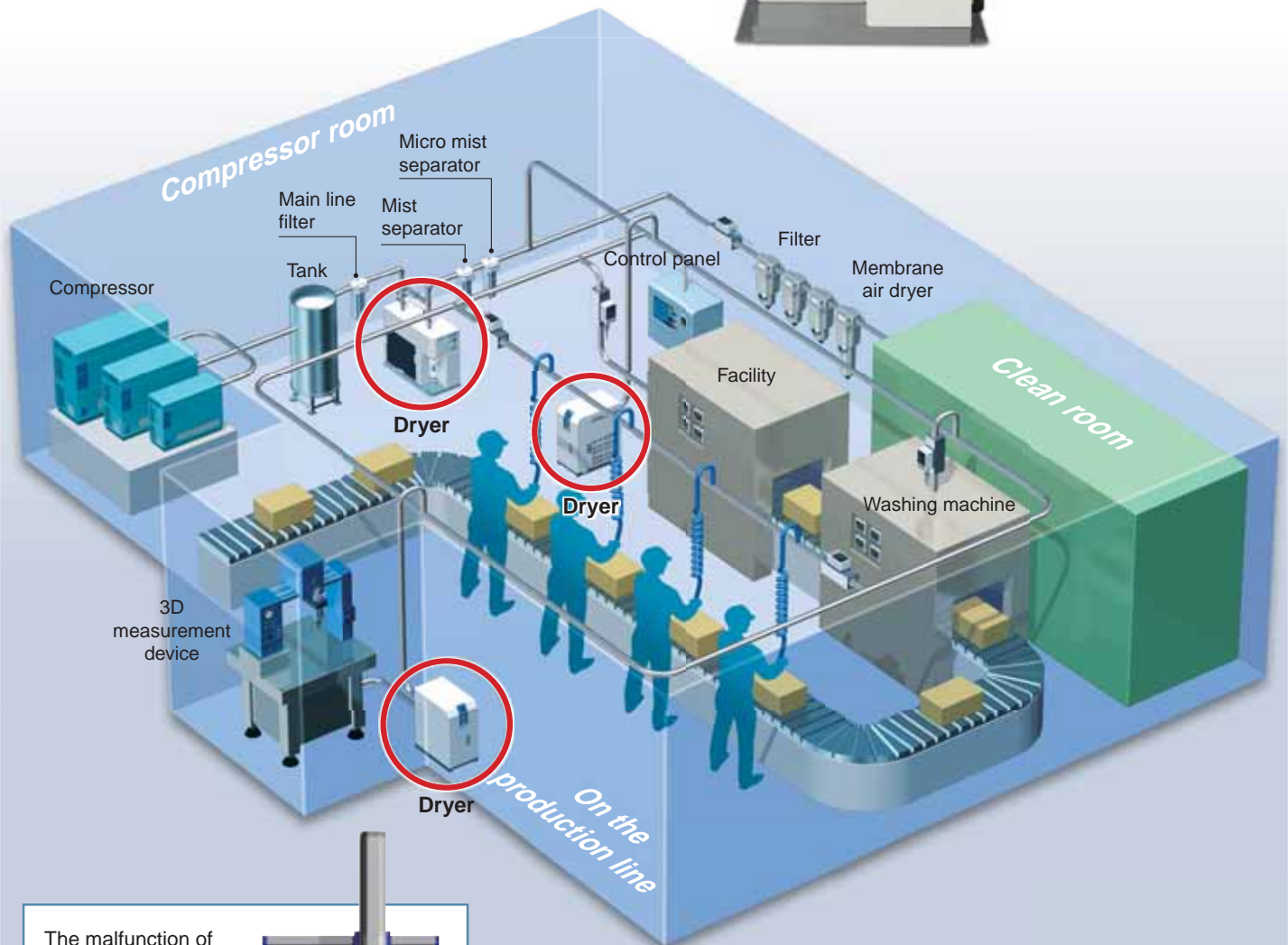

The malfunction of air bearings of 3D measurement device, etc.



IDFA Series Model Selection

Air dryers should be selected based on the corrected air flow capacity while taking operating environment and facility into account. Select the air dryer model in accordance with the following procedure.

1 Read the correction factors.

Read the correction factors **A** to **C** suitable to the operating conditions.

2 Calculate the corrected air flow capacity.

Obtain the corrected air flow capacity from the following formula.

$$\text{Corrected air flow capacity} = \text{Air flow rate} \div (\text{Correction factor } \mathbf{A} \times \mathbf{B} \times \mathbf{C})$$

3 Select the model.

Select the model with air flow capacity exceeding the calculated corrected air flow from data **D** of the table below.

IDFA Selection Example

Condition	Data symbol	Correction factor*1
Inlet air temperature	40 °C	A 0.71
Ambient temperature	30 °C	B 0.85
Inlet air pressure	0.6 MPa	C 0.89
Air flow rate	250 m ³ /h (ANR)	—
Outlet air pressure dew point	3 °C	—

*1 Values obtained from the table below

Corrected air flow capacity

$$= 250 \text{ m}^3/\text{h (ANR)} \div (0.71 \times 0.85 \times 0.89)$$

$$= 465 \text{ m}^3/\text{h (ANR)}$$

The model which exceeds the correct air flow capacity of 465 m³/h (ANR) is IDFA80.

Data **A**: Inlet Air Temperature

°C	5 to 25	30	35	40	45	50	55	60	65
Correction factor	1.42	1.15	1.00	0.71	0.62	0.50	0.40	0.33	0.21

Data **B**: Ambient Temperature

°C	2 to 25	30	35	40	45
Correction factor	1.00	0.85	0.80	0.73	0.62

Data **C**: Inlet Air Pressure

MPa	0.3	0.4	0.5	0.6	0.7 to 1.6
Correction factor	0.71	0.75	0.82	0.89	1.00

Data **D**: Air Flow Capacity

Model		Air flow capacity m ³ /h (ANR)			
		IDFA60	IDFA70	IDFA80	IDFA90
Outlet air pressure dew point	3°C	204	312	552	810
	7°C	300	408	654	900
	10°C	360	480	720	960

* Refer to page 9 for options.

* Refer to page 8 for optional accessories.

Refrigerated Air Dryer

IDFA60/70/80/90 Series

(Max. inlet air temperature: 65 °C, Max. ambient temperature: 45 °C)

How to Order

IDFA **60** - **23** -

Size

60
70
80
90

Voltage

Symbol	Voltage
23	Single-phase 230 VAC (50 Hz)

Options

Symbol	Description
—	None
A	Cool compressed air output
C	Anti-corrosive treatment for copper tube
G	With Chinese labels and a Chinese operation manual
L	With a heavy-duty auto drain (The maximum operating pressure is 1.6 MPa.)
R	With an earth leakage breaker
T	With a terminal block for operating, error, and remote operation signals
V	With a timer controlled solenoid valve type auto drain (The maximum operating pressure is 1.6 MPa.)

* When multiple options are combined, indicate symbols in alphabetical order.

* The combination of L and V is not available.

Replacement Parts

Auto drain

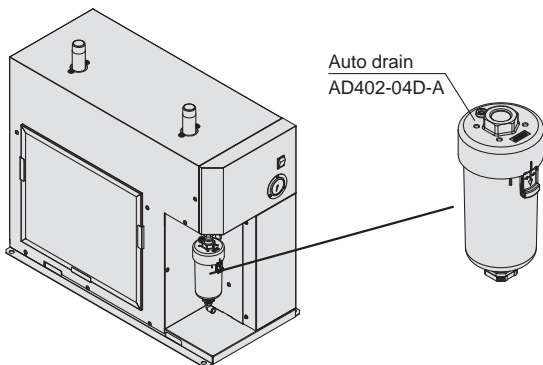

Auto Drain Replacement Part Nos.

Description	Part no.	Qty.
Element	AD402P-040S	1
Bowl O-ring	KA00463	1
Bowl assembly*1	AD52-A	1

*1 A bowl O-ring is included.
A One-touch fitting for connecting the drain tube is not included.

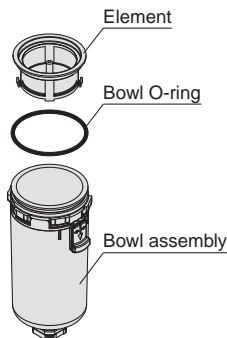

Dustproof filter

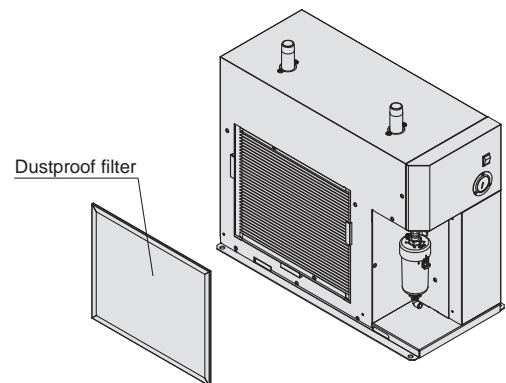

Dustproof Filter Replacement Part Nos.

Part no.	Qty.	Dimension [mm]	Applicable model
IDF-S0530	1	H370 x W440	For IDFA60
IDF-S0531	1	H614 x W440	For IDFA70
IDF-S0535	1	H614 x W556	For IDFA80, IDFA90

Standard Specifications



Specifications		Model	IDFA60	IDFA70	IDFA80	IDFA90	
Operating range*1	Fluid	Compressed air					
	Inlet air temperature [°C]	5 to 65					
	Inlet air pressure [MPa]	0.15 to 1.0*9					
	Ambient temperature (Humidity) [°C]	2 to 45 (Relative humidity: 85% or less)					
Rated conditions*4	Air flow capacity [m³/h]	Standard condition (ANR)*2	Outlet air pressure dew point 3 °C	204	312	552	810
			Outlet air pressure dew point 7 °C	300	408	654	900
			Outlet air pressure dew point 10 °C	360	480	720	960
		Compressor intake condition*3	Outlet air pressure dew point 3 °C	216	331	585	859
			Outlet air pressure dew point 7 °C	318	432	693	954
			Outlet air pressure dew point 10 °C	382	509	763	1018
	Inlet air pressure [MPa]		0.7				
	Inlet air temperature [°C]		35				
	Ambient temperature [°C]		25				
	Power supply voltage (Frequency)		Single-phase 230 VAC (50 Hz) Allowable voltage range ±10 %*5				
Maximum air flow capacity		Air flow capacity calculated with the correction factors					
Electric spec.	Power consumption *6 [W]	820	1300	1950	2220		
	Current consumption *6 [A]	4.9	7.2	12.0	13.0		
	Applicable earth leakage breaker capacity *7 [A]	10	15	20	30		
Cooling method		Air-cooled refrigeration					
Refrigerant		R410A (HFC) GWP: 2088*8					
Refrigerant charge [g]		390 ±10	530 ±10	630 ±10	780 ±10		
Auto drain		Float type (Normally open, Min. operating pressure: 0.1 MPa)					
Port size		R1	R1 1/2	R2			
Weight [kg]		49	68	95	110		
Accessories		Drain tube (ø12: 3.5 m), Drain tube holder, Operation manual					

Symbol

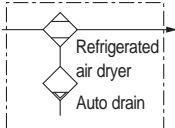

- *1 The operating range does not guarantee use with normal air flow capacity.
- *2 Air flow capacity under the standard condition (ANR) [atmospheric pressure 20 °C, relative humidity 65 %]
- *3 Air flow capacity converted by the compressor intake condition [32 °C, Atmospheric pressure, and 75 % relative humidity]
- *4 When the operating conditions are different from the rated values, select a model in accordance with Model Selection (page 4) or calculate the air flow capacity suitable to the operating conditions based on the Correction of Air Flow Capacity.
- *5 Do not use this product with continuous voltage fluctuations.
- *6 These values are reference values under rated conditions and are not guaranteed. Do not use these values for the thermal relay set values, etc.
- *7 Products other than Option R are not equipped with an earth leakage breaker. Purchase an appropriate earth leakage breaker separately. Use an earth leakage breaker with a leak current sensitivity of 30 mA.
- *8 This is the value specified by IPCC4 AR4. The value specified by the Revised Fluorocarbons Recovery and Destruction Law (Japanese law) is R410A GWP: 2090.
- *9 The maximum operating pressure is 1.0 MPa as standard, but it is possible to achieve 1.6 MPa when selecting Option L or Option V.

Correction of Air Flow Capacity

Inlet air temperature [°C]

°C	5 to 25	30	35	40	45	50	55	60	65
Correction factors	1.42	1.15	1.00	0.71	0.62	0.50	0.40	0.33	0.21

Ambient temperature [°C]

°C	2 to 25	30	35	40	45
Correction factors	1.00	0.85	0.80	0.73	0.62

Inlet air pressure [MPa]

MPa	0.3	0.4	0.5	0.6	0.7 to 1.6
Correction factors	0.71	0.75	0.82	0.89	1.00

Calculation example: The air flow capacity when the dew point of the IDFA60 is set to 10 °C under the following conditions is calculated. [Operating conditions: Inlet air temperature: 35 °C, Ambient temperature: 35 °C, Inlet air pressure: 0.6 MPa] 360 m³/h (ANR) x 1.00 x 0.80 x 0.89 = 256 m³/h (ANR)

IDFA Series

Construction (Air/Refrigerant Circuit)

Humid, hot air coming into the air dryer will be cooled down by a cooler re-heater (heat exchanger). Water condensed at this time will be removed from the air by an auto drain and drained out automatically. Air separated from the water will be heated by a cooler re-heater (heat exchanger) to obtain the dried air, which goes through to the outlet side.

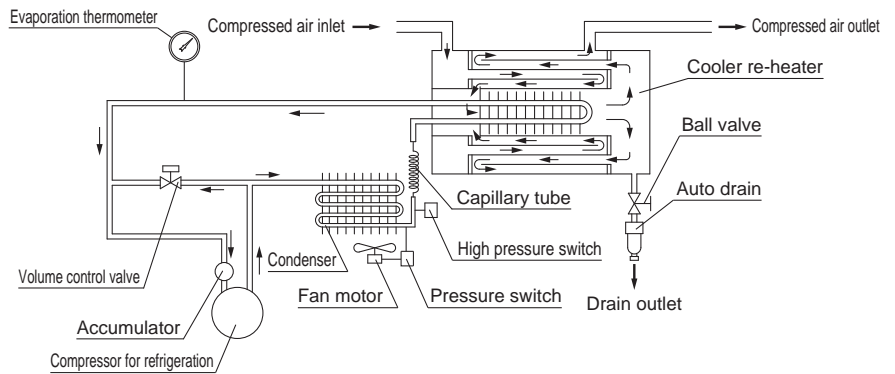

Dimensions

IDFA60, 70, 80, 90

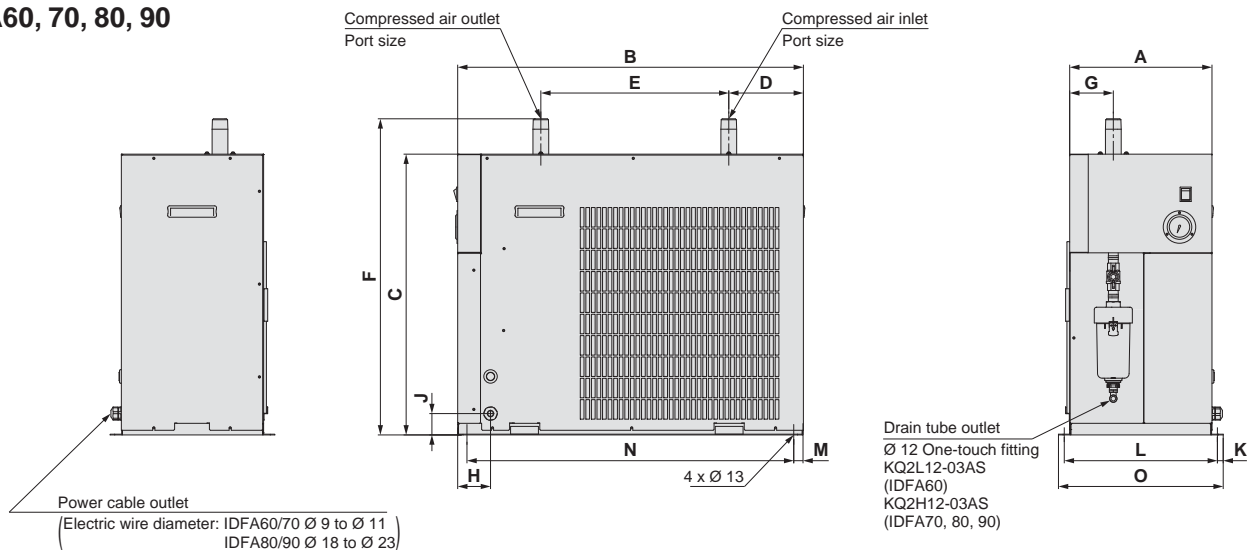

															[mm]
Model	Port size	A	B	C	D	E	F	G	H	J	K	L	M	N	O
IDFA60	R1	307	745	605	161	405	681	94	71	46	12.5	330	20	704	355
IDFA70	R1 1/2	342	890	825	176	905	905		68			365		849	390
IDFA80	R2	438	957	863	169	480	958	219	78	100	11	463		916	485
IDFA90															

IDFA Series Optional Accessories

Foundation Bolt Set

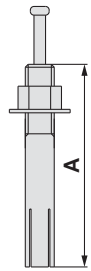

For fixing the air dryer to the foundations.
Easy to secure by striking the axle.

Mounting hole dia.: $\varnothing 10.5$

Part no.	Nominal thread size	Material	Number of 1 set	A
IDF-AB500	M10	Stainless steel	4	50

Piping Adapter

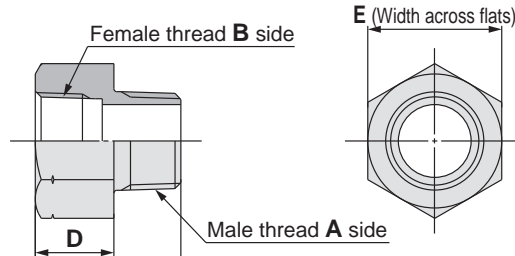

For converting the thread type of an IN/OUT fitting for air dryers.

Part no.	Thread type and port size		C	D	E	Material	Number of 1 set
	Male thread A side	Female thread B side					
IDF-AP604	NPT1	Rc1	50	27	46	Brass	2
IDF-AP606	NPT1 1/2	Rc1 1/2	55	31	54		
IDF-AP607	NPT2	Rc2	65	30	70		

Bypass Piping Set

IDF – BP 339

Applicable air dryer

Symbol	Applicable dryer
339	IDFA60
340	IDFA70
341	IDFA80
	IDFA90

Max. operating pressure: 1.0 MPa

* Not applicable to the moderate pressure specification
Prepare a bypass piping set suitable for the specification.

For IDFA60: IDF-BP339

Weight: 5 kg

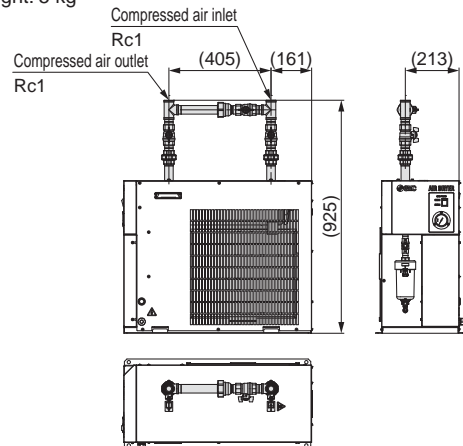

For IDFA70: IDF-BP340

Weight: 10 kg

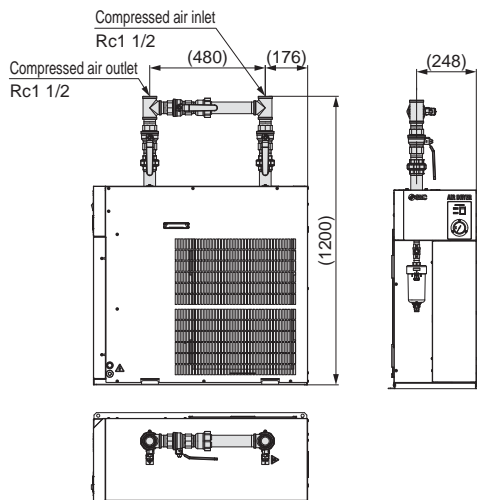

For IDFA80, IDFA90: IDF-BP341

Weight: 14 kg

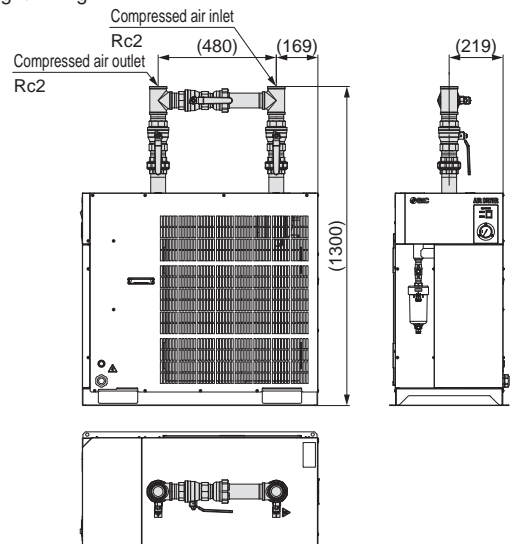

IDFA Series Options

A Option symbol

Cool compressed air output

Cool outlet air (10 °C) can be supplied.
The air flow with this option is smaller than that of the standard air dryer.
(Refer to the table below.)
If the air dryer is used out of the scope of the rated specifications or conditions, select a model according to page 4 and apply the air flow capacity shown in the table below to the data ②.

* Perform thermal insulation treatment for pipings and equipment installed after the dryer to prevent the formation of condensation.

Air Flow Capacity

Model		Air flow capacity m ³ /h (ANR)			
		IDFA60-23-A	IDFA70-23-A	IDFA80-23-A	IDFA90-23-A
Outlet air pressure dew point	10 °C	186	300	462	576

Rated conditions: Inlet air pressure: 0.7 MPa, Inlet air temperature: 35 °C, Outlet air temperature: 10 °C

C Option symbol

Anti-corrosive treatment for copper tube

This minimises the corrosion of the copper and copper alloy parts when the air dryer is used in an atmosphere containing hydrogen sulfide or sulfuric acid gas. (Corrosion cannot be completely prevented.)
Special epoxy coating: Copper tube and copper alloy parts. The coating is not applied on the heat exchanger or around electrical parts, where operation may be affected by the coating.

* Failure due to corrosion is not covered under warranty.

G Option symbol

With Chinese labels and a Chinese operation manual

In addition, Chinese labels are put on the external panels.
A Chinese operation manual is also included.

L Option symbol

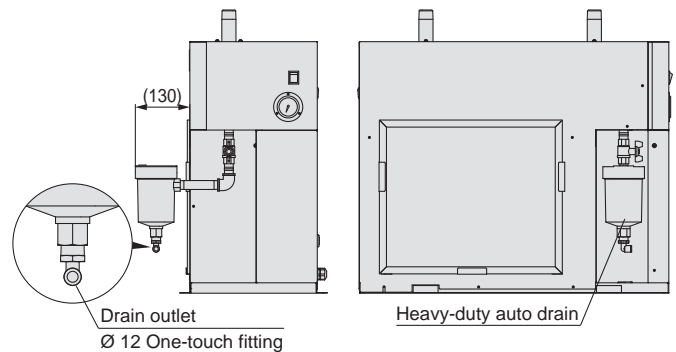

With a heavy-duty auto drain (applicable to moderate pressure)

The float type auto drain used in the standard air dryer is replaced with a heavy-duty auto drain (ADH4000-04) which enables the condensate to discharge more efficiently. The product can be used for moderate pressure with this option.
Max. operating pressure: 1.6 MPa



* The heavy-duty auto drain and piping materials (nipple, elbow) are shipped together with the main body of the air dryer. Customers are required to mount the parts to the air dryer.

Replacement Parts: Heavy-Duty Auto Drain

Replacement part no. (Description)	Configuration
ADH4000-04 (Heavy-duty auto drain)	 Heavy-duty auto drain
ADH-E400 (Replacement kit for exhaust mechanism)	 Replacement kit for exhaust mechanism
	 Housing (Use existing equipment.)

R Option symbol

With an earth leakage breaker

The air dryer is equipped with an earth leakage breaker, reducing the electrical wiring required during installation.

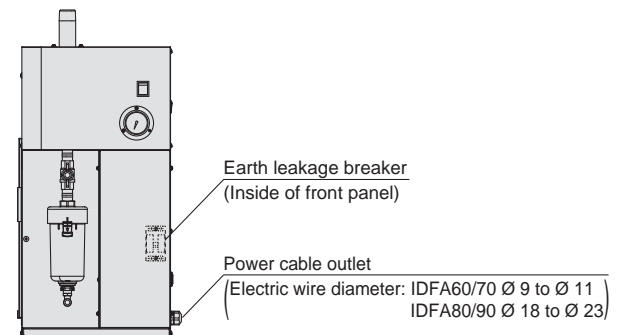

T Option symbol**With a terminal block for operating, error, and remote operation signals**

In addition to power supply connection, terminal blocks for operating, error, and remote operation signals are available.

- The operating and error signals are no-voltage contact style.
 - Operating signal...During operation: contact "close", During stop: contact "open"
 - Error signal...During error: contact "close", During stop: contact "open"
- Contact capacity...Rated load voltage: 240 VAC or less/24 VDC or less
 - Max. load current: 5 A (Resistance load)/2 A (Induction load)
 - Min. applicable load: 20 VDC, 3 mA
- Power supply voltage is applied to the remote operation contact. The external switch is to be prepared by customers. Position holding switch (alternate type switch) or automatic return switch (momentary switch) can be used.

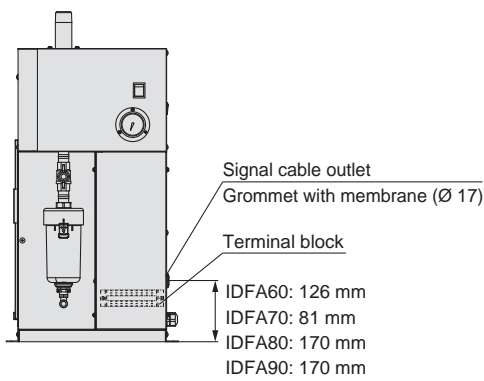
**V** Option symbol**With a timer controlled solenoid valve type auto drain (applicable to moderate pressure)**

Drainage is discharged by controlling a solenoid valve with a timer. A strainer for solenoid valve protection and a stop valve are also included.

Max. operating pressure: 1.6 MPa

Replacement Parts

Part no.	Note
IDF-S0534	200 to 230 VAC

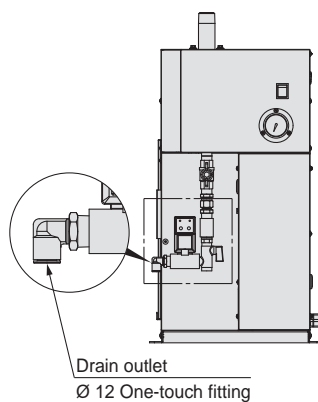



IDFA Series

Specific Product Precautions 1

Be sure to read this before handling the products. Refer to the back cover for safety instructions. For air preparation equipment precautions, refer to the "Handling Precautions for SMC Products" and the "Operation Manual" on the SMC website: <https://www.smc.eu>

Installation

⚠ Caution

- Avoid locations where the air dryer will be in direct contact with wind or rain. (Avoid locations where relative humidity is 85 % or more.)
- Avoid locations where water, water vapour, salt water, or oil may splash on the product.
- Avoid locations where dust or other particles are present.
- Avoid locations where flammable or explosive gases are present.
- Avoid locations where corrosive gases, solvents, or combustible gases are present.
- Avoid locations which receive direct sunlight or radiated heat.
- Avoid locations where the ambient temperature exceeds the limits as mentioned below.
During operation: 2 to 45 °C
During storage: 0 to 50 °C (when there is no drain water inside of the piping)
- Avoid locations where temperature substantially changes.
- Avoid locations where strong magnetic noise occurs. (Avoid locations where strong electric fields, strong magnetic fields, or surge voltages occur.)
- Avoid locations where static electricity occurs or conditions which make the product discharge static electricity.
- Avoid locations where high frequencies occur.
- Avoid locations where damage is likely to occur due to lightning.
- Avoid installation on machines used for transporting, such as vehicles, ships, etc.
- Avoid locations at altitudes of 2000 meters or higher.
- Avoid locations where strong impacts or vibrations occur.
- Avoid conditions where a massive force strong enough to deform the product is applied or the weight from a heavy object is applied.
- Avoid locations with insufficient space for maintenance.
- Avoid locations where the ventilation grille is obstructed.
- Avoid locations where the air dryer will draw in high-temperature air discharged from an air compressor or other dryer.

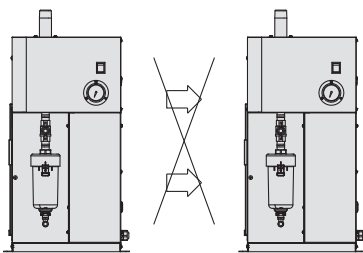

Confirm that the exhaust air does not flow into the neighbouring equipment.

- Avoid pneumatic circuits where rapid pressure fluctuations or flow speed changes are generated.

Drain Tube

⚠ Caution

- A tube with an outside diameter of 12 mm is attached as a drain tube. Use this tube to discharge condensate to a drain tank, etc.
- Do not use the drain tube in an upward direction. Do not bend or crush the drain tube. If it is unavoidable that the tube goes upward, make sure it only goes as far as the position of the auto drain outlet. The drain tube to be prepared should have an O.D. of 12 mm, an I.D. of 8 mm or more, and be 5 m or less in length. Otherwise, the auto drain will not operate correctly, which may cause air to be blown constantly or moisture not to be exhausted.

Power Supply

⚠ Caution

- Connect the power supply to the terminal block.
 - Install an earth leakage breaker*1 suitable to each model for the power supply.
 - Maintain a voltage range within $\pm 10\%$ of the rated voltage. (Do not use this product with continuous voltage fluctuations.)
- *1 Select an earth leakage breaker with a leak current sensitivity of 30 mA.
Regarding the rated current, refer to the Applicable Earth Leakage Breaker Capacity.
- When a short-term interruption of the power supply (including momentary interruptions) occurs in this equipment, the restarting of normal operations may require some time or may be impossible due to the operation of protective devices even after the supply of power returns.

Air Piping

⚠ Caution

- Be careful to avoid any errors in connecting the air piping at the compressed air inlet (IN) and outlet (OUT).
- Flush the piping sufficiently in order to avoid any foreign matter such as dust, sealant tape, liquid gasket, etc., before connecting piping. Foreign matter in the piping can cause cooling failure or drainage failure.
- Inlet and outlet compressed air connections should be made removable by using a union, etc.
- Provide bypass piping to make it possible to do maintenance without stopping the air compressor.
- When tightening the inlet/outlet air piping, firmly hold the port on the air dryer with a pipe wrench, etc.
- Use pipes and fittings that can endure the operating pressure and temperature. Connect them firmly to prevent air leakage.
- Do not allow the load of the piping to lie directly on the air dryer. When mounting any part, such as an air filter, on the fitting at the compressed air inlet or outlet port, support the part to prevent excessive force from being applied to the product.
- Be careful not to let the vibrations of the air compressor transmit.
- If a metallic flexible tubing is used for the inlet/outlet air piping, abnormal noise might be generated in the piping. In such cases, please use steel tubing instead.
- If the temperature of the compressed air on the inlet side is over 65 °C, place an aftercooler after the air compressor. Or, lower the temperature of the place where the air compressor is installed to below 65 °C.
- If the air supply generates high pressure fluctuations (pulsations), take appropriate countermeasures, such as installing an air tank.
- If rapid pressure fluctuations or flow changes occur, install a filter on the dryer outlet to prevent condensate from splashing.
- Variations in operating conditions may cause condensation to form on the surface of the outlet piping. Apply thermal insulation around the piping to prevent condensation from forming.

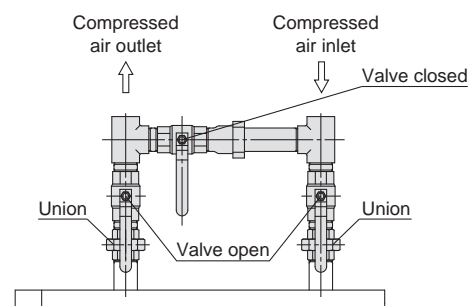



IDFA Series

Specific Product Precautions 2

Be sure to read this before handling the products. Refer to the back cover for safety instructions. For air preparation equipment precautions, refer to the “Handling Precautions for SMC Products” and the “Operation Manual” on the SMC website: <https://www.smc.eu>

Protection Circuit

Caution

When the air dryer is operated in the following cases, the protection circuit will activate, the light will turn off and the air dryer will come to stop.

- The compressed air temperature is too high.
- The compressed air flow rate is too high.
- The ambient temperature is too high. (45 °C or higher)
- The fluctuation of the power supply voltage is beyond $\pm 10\%$ of the rated voltage.
- The air dryer is drawing in high temperature air exhausted from an air compressor or other dryer.
- The ventilation grille is obstructed by a wall or clogged with dust.

Transportation and Installation

Warning

Be sure to follow the instructions below for transporting the product.

- The product is filled with refrigerant. Transport it (by land, sea or air) in accordance with laws and regulations specified.
- When carrying the product, be careful not to let it drop or fall over, and use a forklift.
- Do not lift the product by holding the panel, fittings or piping.
- Never lay the product down for transportation. This may lead to damage to the product.

- The product is heavy and has potential dangers in transportation. Be sure to follow the instructions above.
- Be sure to use a forklift for transporting the product. Weight of each model with packaging: IDFA60: 57 kg, IDFA70: 78 kg, IDFA80: 106 kg, IDFA90: 122 kg

Compressor Air Delivery

Caution

Since the auto drain is designed in such a way that the valve remains open unless the air pressure rises to 0.1 MPa or higher, air will blow out from the drain outlet at the time of air compressor start up until the pressure increases. Therefore, if an air compressor has a small air delivery, the pressure may not be sufficient.

Auto Drain

Caution

The auto drain may not function properly, depending on the quality of the compressed air. Check the operation once a day.

Cleaning of Ventilation Area

Caution

If the dustproof filter becomes clogged with dust or debris, a decline in cooling performance can result.

In order to avoid deforming or damaging the dustproof filter, clean it with a long-haired brush or air gun once a month.

Time Delay for Restarting

Caution

Allow at least three minutes before restarting the air dryer. Otherwise, the protection circuit will activate, the light will turn off and the air dryer will not start up.

Modifying the Standard Specifications

Caution

Do not modify the standard product using any of the optional specifications once the product has been supplied to a customer. Check the specifications carefully before selecting an air dryer.

■ Refrigerant with GWP Reference



Refrigerant	Global Warming Potential (GWP)	
	Regulation (EU) No 517/2014 (Based on the IPCC AR4)	Revised Fluorocarbons Recovery and Destruction Law (Japanese law)
R134a	1430	1430
R404A	3922	3920
R407C	1774	1770
R410A	2088	2090

* This product is hermetically sealed and contains fluorinated greenhouse gases (HFC). When this product is sold on the market in the EU after January 1, 2017, it needs to be compliant with the quota system of the F-Gas Regulation in the EU.

* See specification table for refrigerant used in the product.

Safety Instructions

These safety instructions are intended to prevent hazardous situations and/or equipment damage. These instructions indicate the level of potential hazard with the labels of “Caution,” “Warning” or “Danger.” They are all important notes for safety and must be followed in addition to International Standards (ISO/IEC)¹⁾, and other safety regulations.

-  **Caution:** **Caution** indicates a hazard with a low level of risk which, if not avoided, could result in minor or moderate injury.
-  **Warning:** **Warning** indicates a hazard with a medium level of risk which, if not avoided, could result in death or serious injury.
-  **Danger:** **Danger** indicates a hazard with a high level of risk which, if not avoided, will result in death or serious injury.

- 1) ISO 4414: Pneumatic fluid power – General rules relating to systems.
ISO 4413: Hydraulic fluid power – General rules relating to systems.
IEC 60204-1: Safety of machinery – Electrical equipment of machines.
(Part 1: General requirements)
ISO 10218-1: Manipulating industrial robots - Safety.
etc.

Warning

1. The compatibility of the product is the responsibility of the person who designs the equipment or decides its specifications.

Since the product specified here is used under various operating conditions, its compatibility with specific equipment must be decided by the person who designs the equipment or decides its specifications based on necessary analysis and test results. The expected performance and safety assurance of the equipment will be the responsibility of the person who has determined its compatibility with the product. This person should also continuously review all specifications of the product referring to its latest catalogue information, with a view to giving due consideration to any possibility of equipment failure when configuring the equipment.

2. Only personnel with appropriate training should operate machinery and equipment.

The product specified here may become unsafe if handled incorrectly. The assembly, operation and maintenance of machines or equipment including our products must be performed by an operator who is appropriately trained and experienced.

3. Do not service or attempt to remove product and machinery/equipment until safety is confirmed.

1. The inspection and maintenance of machinery/equipment should only be performed after measures to prevent falling or runaway of the driven objects have been confirmed.
2. When the product is to be removed, confirm that the safety measures as mentioned above are implemented and the power from any appropriate source is cut, and read and understand the specific product precautions of all relevant products carefully.
3. Before machinery/equipment is restarted, take measures to prevent unexpected operation and malfunction.

4. Contact SMC beforehand and take special consideration of safety measures if the product is to be used in any of the following conditions.

1. Conditions and environments outside of the given specifications, or use outdoors or in a place exposed to direct sunlight.
2. Installation on equipment in conjunction with atomic energy, railways, air navigation, space, shipping, vehicles, military, medical treatment, combustion and recreation, or equipment in contact with food and beverages, emergency stop circuits, clutch and brake circuits in press applications, safety equipment or other applications unsuitable for the standard specifications described in the product catalogue.
3. An application which could have negative effects on people, property, or animals requiring special safety analysis.
4. Use in an interlock circuit, which requires the provision of double interlock for possible failure by using a mechanical protective function, and periodical checks to confirm proper operation.

Caution

1. The product is provided for use in manufacturing industries.

The product herein described is basically provided for peaceful use in manufacturing industries.
If considering using the product in other industries, consult SMC beforehand and exchange specifications or a contract if necessary.
If anything is unclear, contact your nearest sales branch.

Limited warranty and Disclaimer/Compliance Requirements

The product used is subject to the following “Limited warranty and Disclaimer” and “Compliance Requirements”. Read and accept them before using the product.

Limited warranty and Disclaimer

1. The warranty period of the product is 1 year in service or 1.5 years after the product is delivered, whichever is first.²⁾ Also, the product may have specified durability, running distance or replacement parts. Please consult your nearest sales branch.
 2. For any failure or damage reported within the warranty period which is clearly our responsibility, a replacement product or necessary parts will be provided. This limited warranty applies only to our product independently, and not to any other damage incurred due to the failure of the product.
 3. Prior to using SMC products, please read and understand the warranty terms and disclaimers noted in the specified catalogue for the particular products.
- 2) Vacuum pads are excluded from this 1 year warranty.
A vacuum pad is a consumable part, so it is warranted for a year after it is delivered. Also, even within the warranty period, the wear of a product due to the use of the vacuum pad or failure due to the deterioration of rubber material are not covered by the limited warranty.

Compliance Requirements

1. The use of SMC products with production equipment for the manufacture of weapons of mass destruction (WMD) or any other weapon is strictly prohibited.
2. The exports of SMC products or technology from one country to another are governed by the relevant security laws and regulations of the countries involved in the transaction. Prior to the shipment of a SMC product to another country, assure that all local rules governing that export are known and followed.

Caution

SMC products are not intended for use as instruments for legal metrology.

Measurement instruments that SMC manufactures or sells have not been qualified by type approval tests relevant to the metrology (measurement) laws of each country. Therefore, SMC products cannot be used for business or certification ordained by the metrology (measurement) laws of each country.

Safety Instructions

Be sure to read “Handling Precautions for SMC Products” (M-E03-3) before using.

Revision History		
Edition B	- The option (with a timer controlled solenoid valve type auto drain) has been added.	XO
Edition Bb	- An option with cool compressed air output has been added. An option with Chinese labels and a Chinese operation manual has been added. - A bypass piping set has been added as an optional accessory. - Number of pages has been increased from 12 to 16.	XW

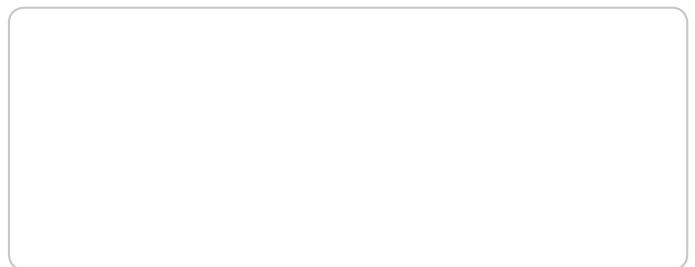

SMC Corporation (Europe)

Austria	+43 (0)2262622800	www.smc.at	office@smc.at
Belgium	+32 (0)33551464	www.smc.be	info@smc.be
Bulgaria	+359 (0)2807670	www.smc.bg	office@smc.bg
Croatia	+385 (0)13707288	www.smc.hr	office@smc.hr
Czech Republic	+420 541424611	www.smc.cz	office@smc.cz
Denmark	+45 70252900	www.smc.dk.com	smc@smcdk.com
Estonia	+372 6510370	www.smc.pneumatics.ee	info@smcee.ee
Finland	+358 207513513	www.smc.fi	smc.fi@smc.fi
France	+33 (0)164761000	www.smc-france.fr	info@smc-france.fr
Germany	+49 (0)61034020	www.smc.de	info@smc.de
Greece	+30 210 2717265	www.smchellas.gr	sales@smchellas.gr
Hungary	+36 23513000	www.smc.hu	office@smc.hu
Ireland	+353 (0)14039000	www.smcautomation.ie	sales@smcautomation.ie
Italy	+39 0292711	www.smcitalia.it	mailbox@smcitalia.it
Latvia	+371 67817700	www.smc.lv	info@smc.lv

Lithuania	+370 5 2308118	www.smclt.lt	info@smclt.lt
Netherlands	+31 (0)205318888	www.smc.nl	info@smc.nl
Norway	+47 67129020	www.smc-norge.no	post@smc-norge.no
Poland	+48 222119600	www.smc.pl	office@smc.pl
Portugal	+351 214724500	www.smc.eu	apoioclientept@smc.smces.es
Romania	+40 213205111	www.smcromania.ro	smcromania@smcromania.ro
Russia	+7 8123036600	www.smc.eu	sales@smcru.com
Slovakia	+421 (0)413213212	www.smc.sk	office@smc.sk
Slovenia	+386 (0)73885412	www.smc.si	office@smc.si
Spain	+34 945184100	www.smc.eu	post@smc.smces.es
Sweden	+46 (0)86031200	www.smc.nu	smc@smc.nu
Switzerland	+41 (0)523963131	www.smc.ch	info@smc.ch
Turkey	+90 212 489 0 440	www.smc.pnomatik.com.tr	info@smcpnomatik.com.tr
UK	+44 (0)845 121 5122	www.smc.uk	sales@smc.uk