

Non F-Gas
(CO₂ Refrigerant)

Circulating Fluid Temperature Controller
Refrigerated Thermo-chiller **New**

GWP = 1

Non F-Gas
CO₂ Refrigerant



SEMI Standard
S2, S8, F47



HRZC Series



CAT.EUS40-82A-UK

Air transport possible

Uses a CO₂ refrigerant

Greatly reduced GWP

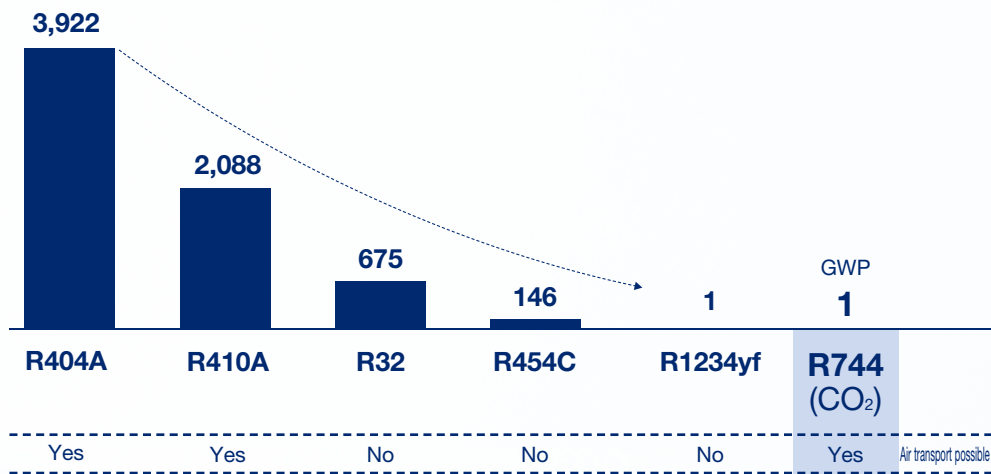

GWP = 1 Compliant with each country's refrigerant regulations As of the end of September 2024

EU refrigerant regulations : GWP150 or more

US refrigerant regulations : GWP700 or more

California, US refrigerant regulations: GWP750 or more

* "GWP" indicates the global warming potential. The values are based on the IPCC AR4.

Air transport possible

Classified as A1 according to ASHRAE standard 34 (non-toxic and non-flammable)

Eliminates the need to pay for F-Gas recovery & disposal

Eliminates the need for periodic inspections based on the Fluorocarbon Emissions Control Act (Japan)



Temperature Stability

High temperature stability even when the heat load fluctuates

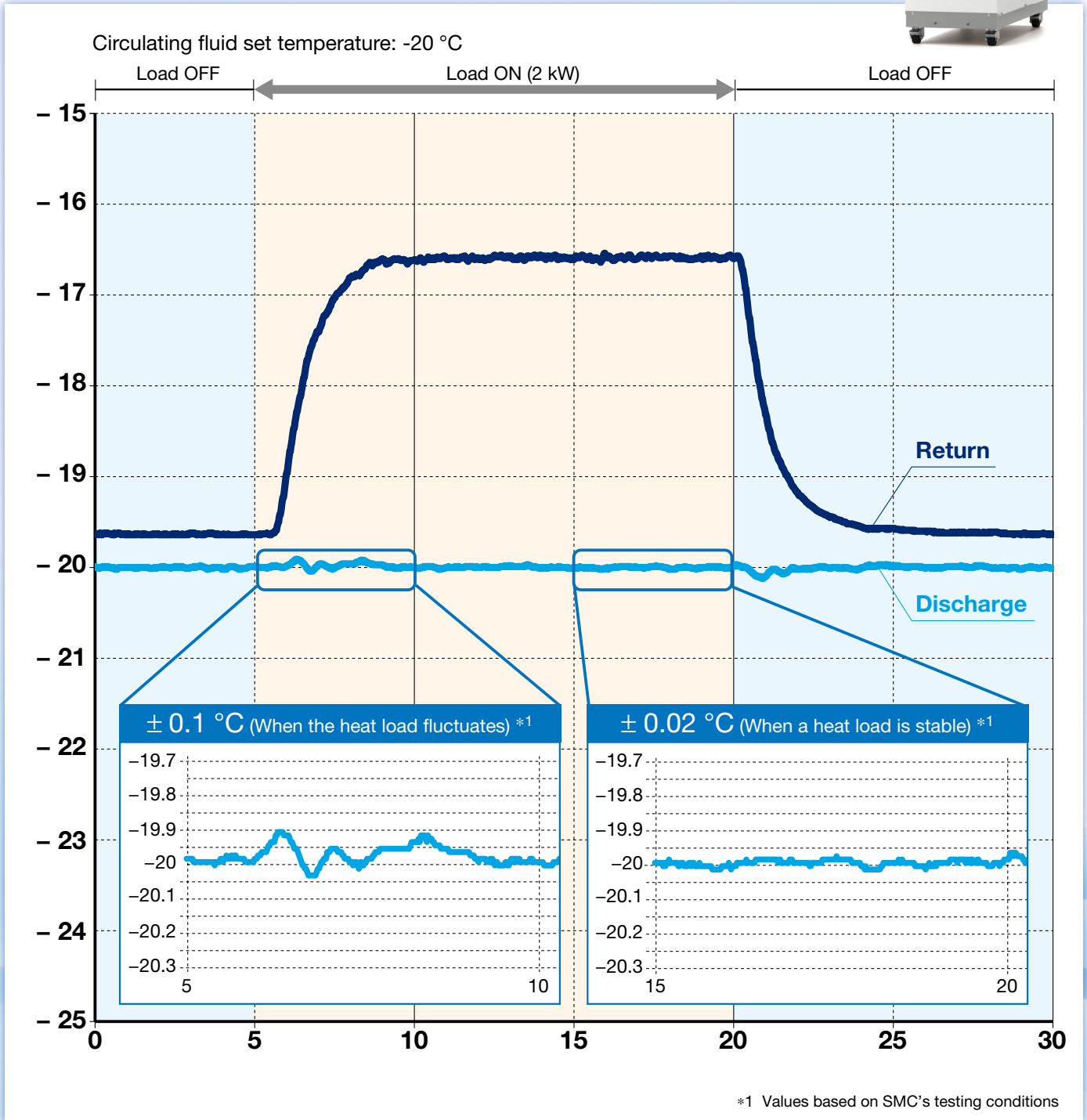

Energy Saving – High energy savings possible due to full use of double inverters –

Reduced power consumption due to DC inverter compressor

Optimal control of compressor rotations according to load

Power consumption comparison with the non F-Gas (CO₂ refrigerant) type

Operating conditions -20 °C, 0 kW with 50 % load, 2 kW with 50 % load, facility water 15 °C

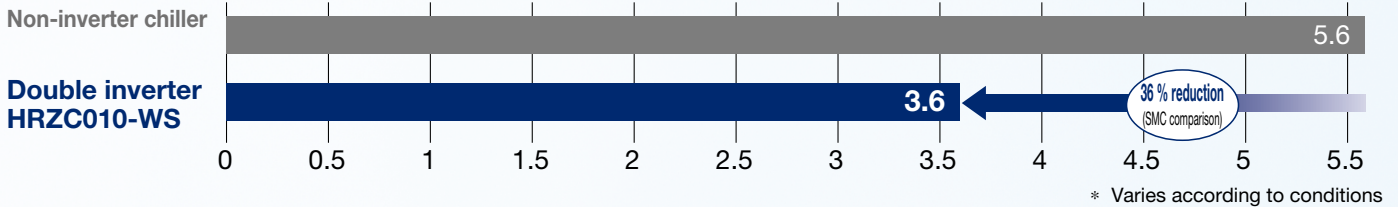

Reduced power consumption due to pump inverter

Changeable set flow rate (Set flow range: 10 to 40 l/min)

Operating conditions 20 °C, 0 kW load, facility water 25 °C, circulating fluid flow rate 20→15→10→15→20 l/min

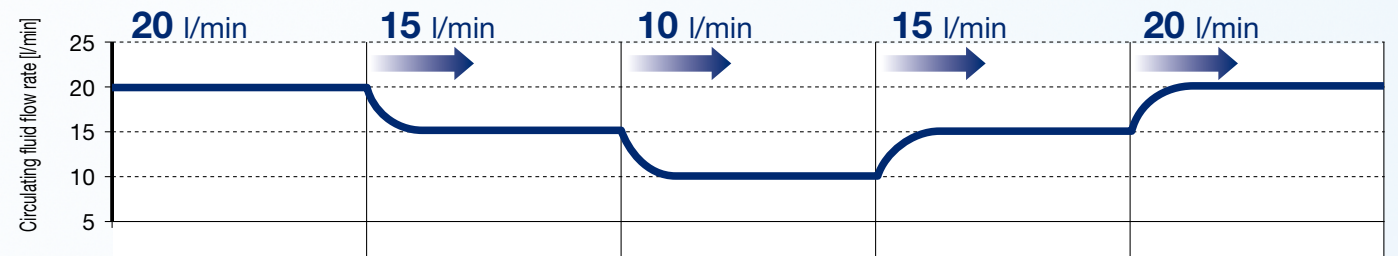

Further improved energy saving possible by changing the set flow rate

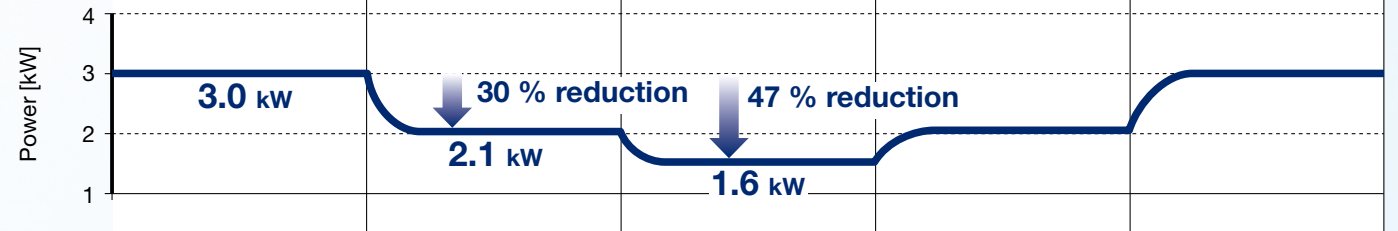

Minimal temperature fluctuations from changes in flow rate, High temperature stability even at 10 l/min

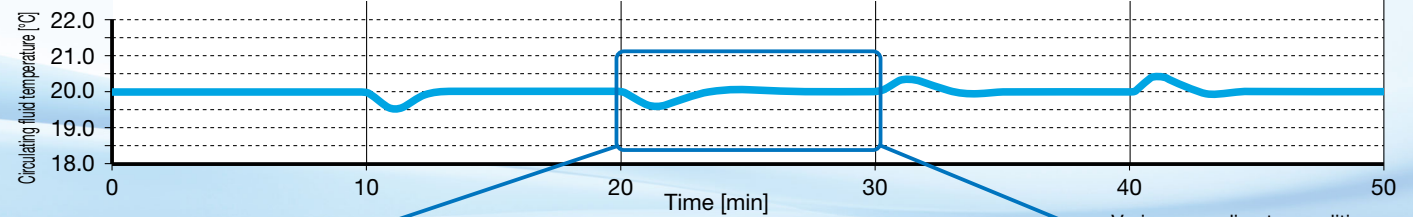

* If the flow rate falls below the rated flow rate, specifications such as the cooling capacity and temperature stability may not be satisfied.

Pump motor efficiency equivalent to IE4 * The motor built into this product is not subject to the high-efficiency motor regulations of each country.

Ensured interchangeability with existing models

- Same external dimensions
- Same wiring, port size, and layout
- Same cooling, heating, and pumping capacity

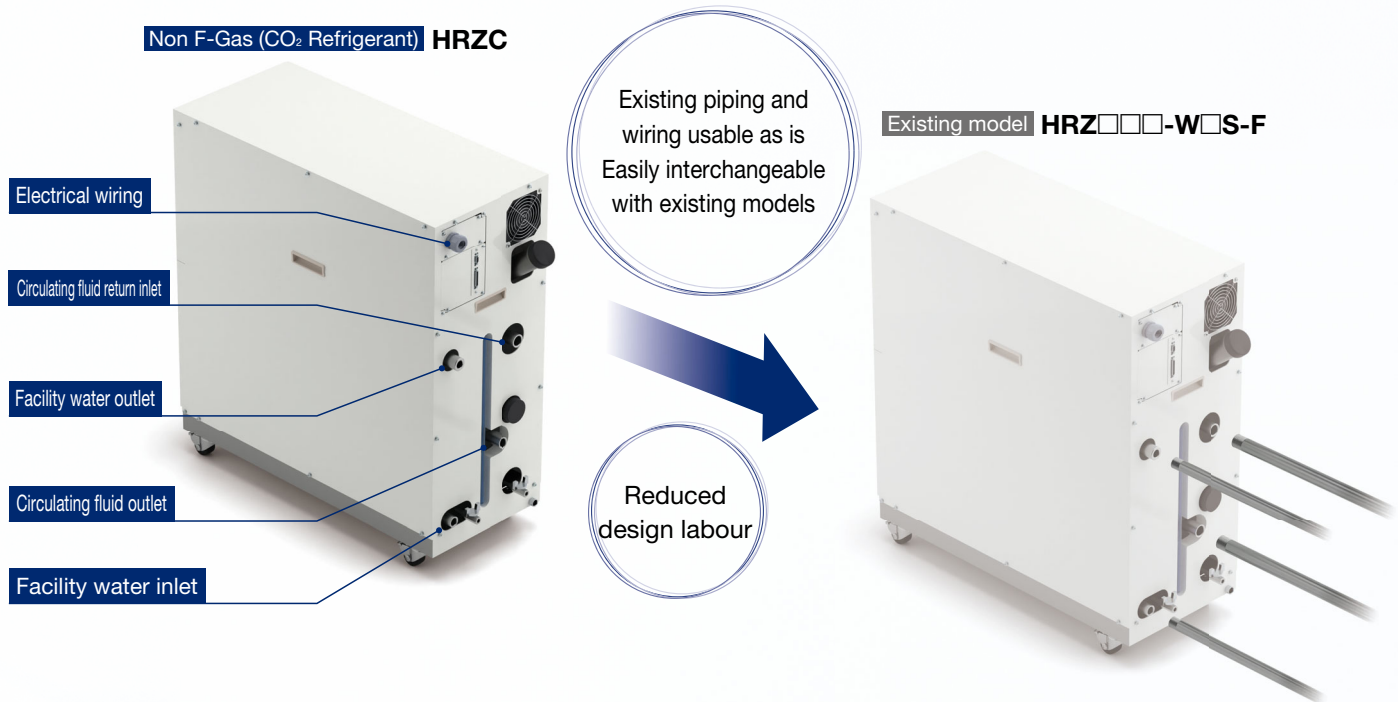

Tuningless

- Easy setting
 - After installation, just set the temperature and flow rate and optimal energy-saving operation is possible via compressor and pump inverter control.
 - Control parameter setting according to the installation conditions not required

Communications

- Contact input/output signal
- Serial RS-485 communication
- Analogue communication (Option **p. 20**)
- DeviceNet communication (Option **p. 20**)

DeviceNet

Trademark
DeviceNet® is a registered trademark of ODVA, Inc.

Leakless

- All-in-one tank
 - Housing the pump or heat exchanger inside the tank has eliminated any external leakage of the circulating fluid

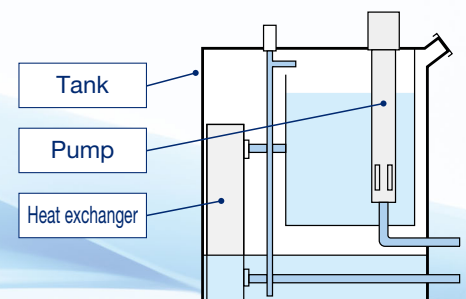

- Fluid contact parts adopt the materials compatible for various circulating fluids.
(Stainless steel, EPDM, etc.)
- Fluorinated fluids: Fluorinert™ FC-3283, FC-40, GALDEN® HT135, HT200
- 60 % ethylene glycol aqueous solution
- Deionised water/Tap water

Regarding the fluid other than the above, please contact SMC.

Fluorinert™ is a trademark of 3M. GALDEN® is a registered trademark, belonging to the Solvay Group or its corresponding owner.

Easy maintenance

■ Circulating fluid automatic recovery function (Option **p. 21**)

Circulating fluid inside a thermo-chiller tank can be recovered automatically.
(Recovery volume: 16 L)

- Reduced maintenance time
- Faster operation
- Reduced circulating liquid loss by evaporation or spill

All you have to do is to push the communication button for recovery and reset!

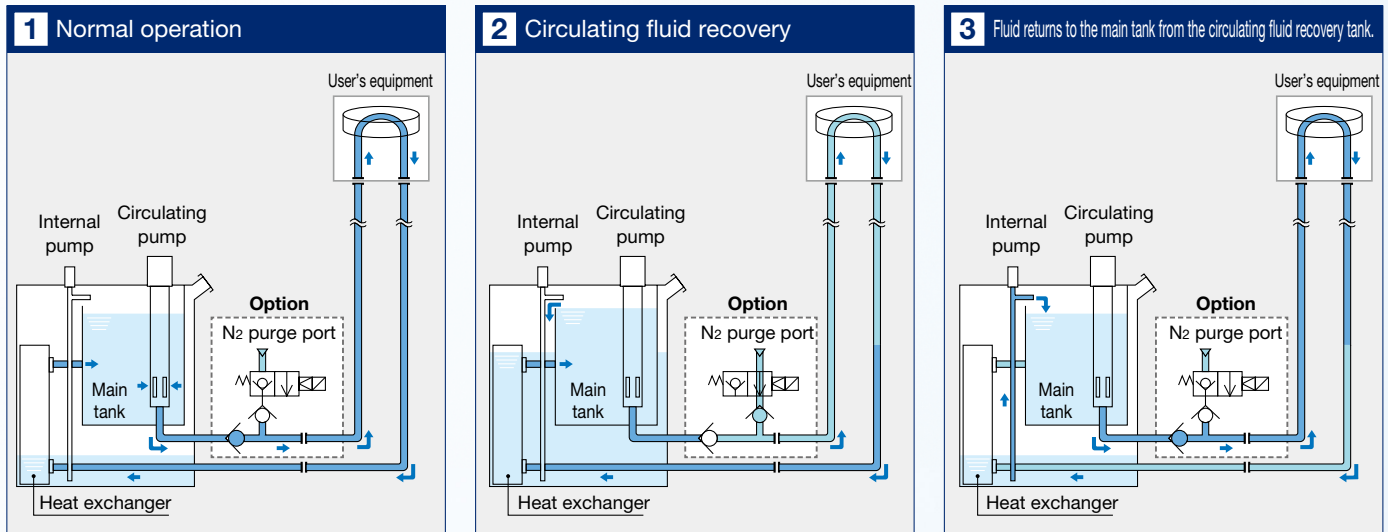
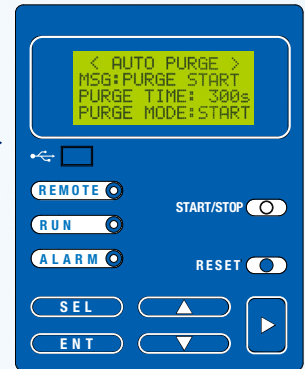

■ Circulating fluid electric resistance ratio control function (Option **p. 20**)

(DI control kit)

Variations

Model	Cooling method	Refrigerant	Circulating fluid	Temperature range setting	Temperature stability	Cooling capacity	Power supply	Option p. 20	Optional accessories p. 22	International standards
HRZC010	Water-cooled refrigeration	R744 (CO ₂)	Fluorinated fluids	- 20 to 90 °C	± 0.1°C	10 kW	3-phase 200 AC/ 200 to 208 V (50/60 Hz)	<ul style="list-style-type: none"> • Analogue communication • DeviceNet communication • NPT fitting • DI control kit*1 • Circulating fluid automatic recovery 	<ul style="list-style-type: none"> • Bypass piping set • Anti-quake bracket • 4-port manifold • DI filter • Insulating material for DI filter • 60 % ethylene glycol aqueous solution • Concentration meter 	<p>SEMI Standard S2, S8, F47</p>
			60 % ethylene glycol aqueous solution							

*1 Not equipped to the fluorinated fluid type

Circulating Fluid/Facility Water Line Related Equipment



SMC's Global Maintenance Network

Products that you can count on available worldwide

Thanks to a solid inventory of maintenance parts and an experienced chiller support team capable of conducting repairs and replacements, SMC is able to respond to customers' issues quickly and precisely.

As SMC's high-quality services are available to customers all over the world, you can rest assured that you'll have our continued support long after purchase.

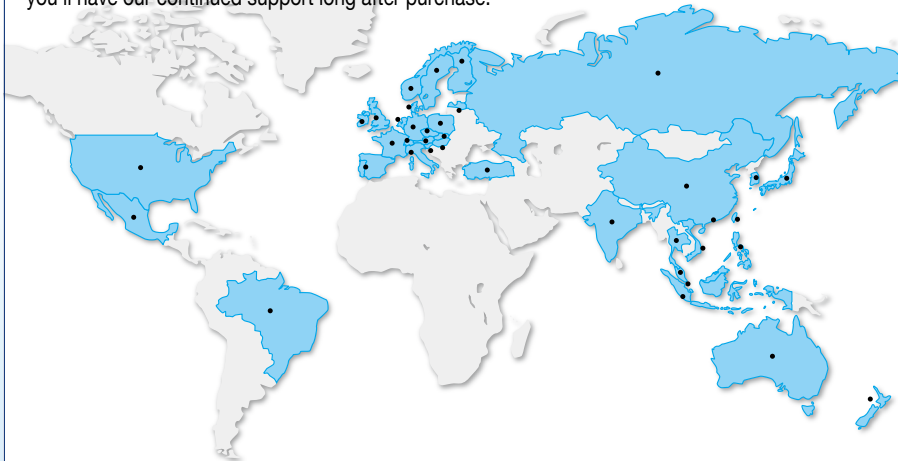

Americas

- Brazil
- Mexico
- U.S.A.

Europe

- Austria
- Czech Republic
- Denmark
- Finland
- France
- Germany
- Hungary
- Ireland
- Italy
- Latvia
- Netherlands
- Norway
- Poland
- Russia
- Slovakia
- Slovenia
- Spain/Portugal
- Sweden
- Switzerland
- Turkey
- U.K.

Asia and Oceania

- Australia
- China
- Hong Kong
- India
- Indonesia
- Japan
- Korea
- Malaysia
- New Zealand
- Philippines
- Singapore
- Taiwan
- Thailand
- Vietnam

* The names of countries and regions listed in each area are alphabetically indexed

Thermo-chiller Business Continuity Plan

Introduction of our BCP initiatives for production factories, engineering, and support systems
We are dedicated to providing a sustainable product supply customers can rely on.

“Uninterrupted Operation and Resilient Supply”



CONTENTS

HRZC Series



Circulating Fluid Temperature Controller

Non F-Gas (CO₂ Refrigerant) Refrigerated Thermo-chiller HRZC Series

● Model Selection

Guide to Model Selection	p. 9
Required Cooling Capacity Calculation	p. 10
Precautions on Model Selection	p. 11
Circulating Fluid Typical Physical Property Values	p. 12

● Thermo-chiller

Pump Inverter and Compressor Inverter Type

How to Order	p. 13
Specifications	p. 13
Cooling Capacity	p. 15
Heating Capacity	p. 15
Pump Capacity (Thermo-chiller Outlet)	p. 15
Dimensions	p. 16
Communication Functions	p. 17
Operation Display Panel	p. 19
Alarm	p. 19

● Options

Analogue Communication	p. 20
DeviceNet Communication	p. 20
NPT Fitting	p. 20
DI Control Kit	p. 20
Circulating Fluid Automatic Recovery	p. 21

● Optional Accessories

① Bypass Piping Set	p. 22
② Anti-quake Bracket	p. 22
③ 4-Port Manifold	p. 23
④ DI Filter	p. 23
⑤ Insulating Material for DI Filter	p. 23
⑥ 60 % Ethylene Glycol Aqueous Solution	p. 24
⑦ Concentration Meter	p. 24

Specific Product Precautions	p. 25
------------------------------	-------

HRZC Series Model Selection

Guide to Model Selection

1. How much is the temperature in degrees centigrade for the circulating fluid?

Temperature range which can be set with the thermo-chiller

-20 °C to 90 °C

Example) User requirement: 20 °C

2. What kind of the circulating fluids will be used?

Relationship between circulating fluid (which can be used with the thermo-chiller) and temperature

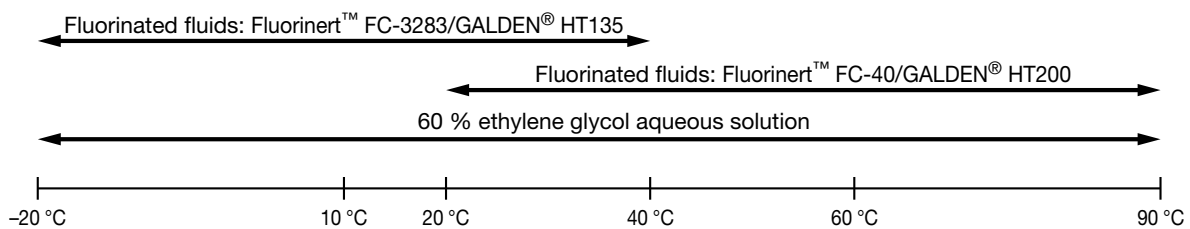

Example) User requirement: Fluorinated fluids

Based on the results in 1 and 2 above,
refer to the cooling capacity charts (page 15) in "Fluorinated fluid."

3. What is the kW for the required cooling capacity?

* To calculate the cooling capacity, referring to page 10.

Example) User requirement: 9 kW →

Plot the point of intersection between the operating temperature (20 °C) and the cooling capacity (9 kW) in the cooling capacity graph.

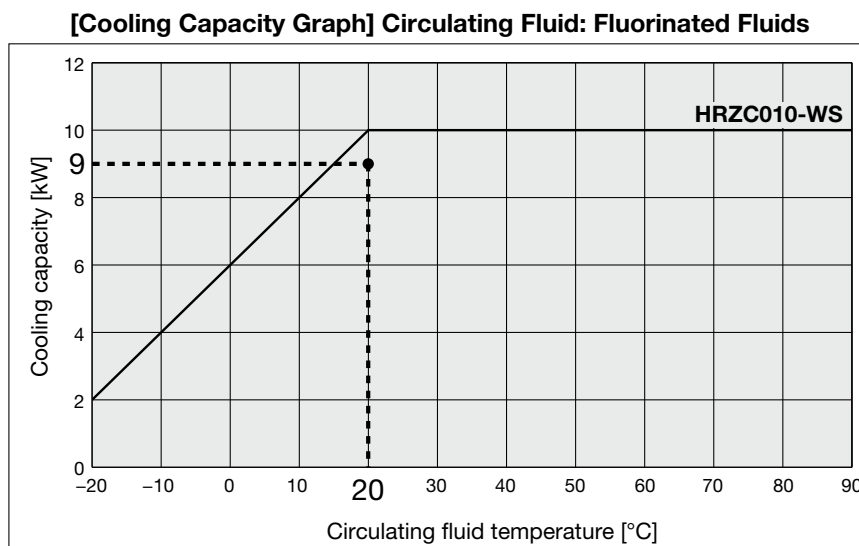

The point plotted in the graph is the requirement from the user. Select the thermo-chiller models exceeding this point. In this case, select the **HRZC010-WS**.

GALDEN® is a registered trademark, belonging to the Solvay Group or its corresponding owner. Fluorinert™ is a trademark of 3M.

Required Cooling Capacity Calculation

Example 1: When the heat generation amount in the user's equipment is known.

Heat generation amount **Q**: 7.5 kW

Cooling capacity = Considering a safety factor of 20 %, $7.5 \times 1.2 = \boxed{9.0 \text{ kW}}$

Example 2: When the heat generation amount in the user's equipment is not known.

Obtain the temperature difference between inlet and outlet by circulating the circulating fluid inside the user's equipment.

Heat generation amount **Q** : Unknown
 Circulating fluid temperature difference $\Delta T (= T2 - T1)$: 13.0 °C (13.0 K)
 Circulating fluid discharge temperature **T1** : 20 °C (293.15 K)
 Circulating fluid return temperature **T2** : 33 °C (299.15 K)
 Circulating fluid flow rate **L** : 20 l/min
 Circulating fluid : Fluorinated fluid
 Density γ : $1.80 \times 10^3 \text{ kg/m}^3$
 Specific heat **C**: $0.96 \times 10^3 \text{ J/(kg}\cdot\text{K)}$ (at 20 °C)

* Refer to page 12 for the typical physical property values by circulating fluid.

$$Q = \frac{\Delta T \times L \times \gamma \times C}{60 \times 1000}$$

$$= \frac{13.0 \times 20 \times 1.80 \times 10^3 \times 0.96 \times 10^3}{60 \times 1000}$$

$$= 7488 \text{ W} \approx 7.5 \text{ kW}$$

Cooling capacity = Considering a safety factor of 20 %, $7.5 \times 1.2 = \boxed{9.0 \text{ kW}}$

Example of conventional units (Reference)

Unknown

13.0 °C

20 °C

33 °C

1.2 m³/h

Fluorinated fluid

Density γ : $1.80 \times 10^3 \text{ kg/m}^3$

Specific heat **C**: 0.23 kcal/kg·°C (at 20 °C)

* Refer to page 12 for the typical physical property values by circulating fluid.

$$Q = \frac{\Delta T \times L \times \gamma \times C}{860}$$

$$= \frac{13.0 \times 1.2 \times 1.80 \times 10^3 \times 0.23}{860}$$

$$\approx 7.5 \text{ kW}$$

Cooling capacity = Considering a safety factor of 20 %, $7.5 \times 1.2 = \boxed{9.0 \text{ kW}}$

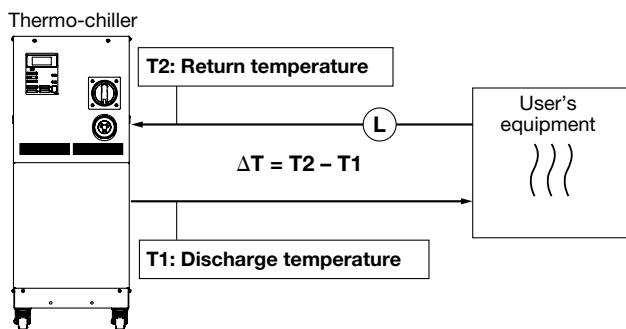

Required Cooling Capacity Calculation

Example 3. When there is no heat generation, and when cooling the object below a certain temperature and period of time.

Cooled substance total volume **V** : 60 L
 Cooling time **h** : 4.6 min
 Cooling temperature difference ΔT : $\left. \begin{array}{l} 20\text{ }^{\circ}\text{C} \text{ (20 K)} \\ (40\text{ }^{\circ}\text{C} - 20\text{ }^{\circ}\text{C} \rightarrow 20\text{ }^{\circ}\text{C}) \end{array} \right\}$
 Circulating fluid : Fluorinated fluid
 Density γ : $1.80 \times 10^3 \text{ kg/m}^3$
 Specific heat **C**: $0.96 \times 10^3 \text{ J/(kg}\cdot\text{K)}$
 (at $20\text{ }^{\circ}\text{C}$)

* Refer to page 12 for the typical physical property values by circulating fluid.

$$Q = \frac{\Delta T \times V \times \gamma \times C}{h \times 60 \times 1000}$$

$$= \frac{20 \times 60 \times 1.80 \times 10^3 \times 0.96 \times 10^3}{4.6 \times 60 \times 1000}$$

$$= 7513 \text{ W} = 7.5 \text{ kW}$$

Cooling capacity = Considering a safety factor of 20 %,

$$7.5 \times 1.2 = 9.0 \text{ kW (When the circulating fluid temperature is } 20\text{ }^{\circ}\text{C.)}$$

(In this case, selected thermo-chiller model will be HRC010-WS.)

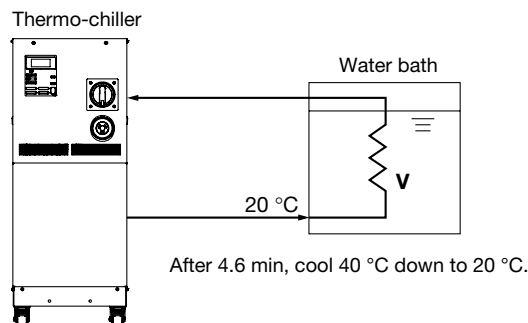

* This is the calculated value by changing the fluid temperature only. Thus, it varies substantially depending on the water bath or piping material or shape.

Precautions on Model Selection

1. Heating capacity

When setting the circulating fluid temperature at a higher temperature than the room temperature, the circulating fluid temperature will be heated with the thermo-chiller. Heating capacity varies depending on the model of the HRZC series. Also, the heating capacity varies depending on the circulating fluid temperature. Consider the heat radiation amount or thermal capacity of the user's equipment. Check beforehand if the required heating capacity is provided, based on the heating capacity graph for the respective model.

2. Pump capacity

<Circulating fluid flow rate>

Pump capacity varies depending on the model selected from the HRZC series. Also, circulating fluid flow varies depending on the circulating fluid discharge pressure. Consider the installation height difference between our thermo-chiller and a user's equipment, and the piping resistance such as circulating fluid pipings, or piping size, or piping curves in the machine. Check beforehand if the required flow is achieved using the pump capacity curves for each respective model.

<Circulating fluid discharge pressure>

Circulating fluid discharge pressure has the possibility to increase up to the maximum pressure in the pump capacity curves for the respective model. Check beforehand if the circulating fluid pipings or circulating fluid circuit of the user's equipment are fully durable against this pressure.

Example of conventional units (Reference)

0.06 m³
 0.68 h
 20 °C
 Fluorinated fluid
 Density γ : $1.80 \times 10^3 \text{ kg/m}^3$
 Specific heat **C**: $0.23 \text{ kcal/kg}\cdot\text{ }^{\circ}\text{C}$
 (at $20\text{ }^{\circ}\text{C}$)

* Refer to page 12 for the typical physical property values by circulating fluid.

$$Q = \frac{\Delta T \times V \times \gamma \times C}{h \times 860}$$

$$= \frac{20 \times 0.06 \times 1.80 \times 10^3 \times 0.23}{0.8 \times 860}$$

$$= 7.2 \text{ kW}$$

Cooling capacity = Considering a safety factor of 20 %,

$$7.2 \times 1.2 = 8.6 \text{ kW (When the circulating fluid temperature is } 20\text{ }^{\circ}\text{C.)}$$

(In this case, selected thermo-chiller model will be HRC010-WS.)

Circulating Fluid Typical Physical Property Values

* Shown below are reference values.
Please contact circulating fluid supplier for details.

Fluorinated Fluids

Physical property value Temperature	Density γ	Specific heat C	
	[kg/m ³] [g/L]	[J/(kg·K)]	[(kcal/kg·°C)]
-10 °C	1.87 x 10 ³	0.87 x 10 ³	(0.21)
20 °C	1.80 x 10 ³	0.96 x 10 ³	(0.23)
50 °C	1.74 x 10 ³	1.05 x 10 ³	(0.25)
80 °C	1.67 x 10 ³	1.14 x 10 ³	(0.27)

60 % Ethylene Glycol Aqueous Solution

Physical property value Temperature	Density γ	Specific heat C	
	[kg/m ³] [g/L]	[J/(kg·K)]	[(kcal/kg·°C)]
-10 °C	1.10 x 10 ³	3.02 x 10 ³	(0.72)
20 °C	1.08 x 10 ³	3.15 x 10 ³	(0.75)
50 °C	1.06 x 10 ³	3.27 x 10 ³	(0.78)
80 °C	1.04 x 10 ³	3.40 x 10 ³	(0.81)

Water

Density γ : 1 x 10³ [kg/m³] [g/L]

Specific heat C: 4.2 x 10³ [J/(kg·K)] (1.0 [kcal/kg·°C])

Non F-Gas (CO₂ Refrigerant)



Thermo-chiller Pump Inverter and Compressor Inverter Type

SEMI

HRZC Series

RoHS



How to Order

HRZC 010 - W [] S - []

Cooling capacity

010	10 kW
-----	-------

Circulating fluid type

-	Fluorinated fluids
1	60 % ethylene glycol aqueous solution

Option

-	None
C	Analogue communication
D	DeviceNet communication
N	NPT fitting
Y*1	DI control kit
Z	Circulating fluid automatic recovery

- *1 Not equipped to the fluorinated fluid type.
- When multiple options are combined, indicate symbols in alphabetical order.

Pump inverter and compressor inverter type

Specifications (Fluorinated Fluid Type)

Model		HRZC010-WS
Channel/Cooling method		1 channel/Water-cooled refrigeration
Temperature control method		PID control
Refrigerant		R744 (CO ₂ , GWP:1)
Refrigerant charge	kg	1.0
Ambient temperature	°C	10 to 35
Ambient humidity*1	%RH	30 to 70
Altitude	m	1000 or less
Circulating fluid*2		Fully fluorinated fluid -20 to 40 °C: Fluorinert™ FC-3283 GALDEN® HT135 20 to 90 °C: Fluorinert™ FC-40 GALDEN® HT200
Temperature range setting*1/Temperature stability*3 °C		-20 to 90/±0.1
Cooling capacity*4 (Under conditions below) kW		10 (4)
Circulating fluid temperature °C		20 (-10)
Facility water temperature °C		25
Circulating fluid flow rate l/min		20
Pump capacity*5 MPa		0.72 (at 20 l/min) With flow control, pressure control, and frequency control function by pump inverter
Rated flow*6 l/min		20
Flow display range l/min		10 to 40
Flow range*7 l/min		10 to 40
Discharge pressure display range MPa		0 to 1.5
Tank	Main tank capacity*8 L	Approx. 15
	Sub-tank capacity*9 L	Approx. 16
Contact material for circulating fluid		Stainless steel, EPDM, Copper brazing (Heat exchanger), Silicone, PPS, Fluororesin
Height difference between this product and customer's equipment m		10 or less
Outlet port size		Rc3/4 (With plug)
Return port size		Rc3/4 (With plug)
Drain port size		Rc3/8 (With valve/plug)
Temperature °C		10 to 30
Inlet pressure MPa		0.3 to 0.7
Inlet-outlet pressure differential of facility water MPa		0.3 or more
Required flow rate*10 l/min		15
Inlet port size		Rc1/2 (With plug)
Outlet port size		Rc1/2 (With plug)
Contact material for cooling water		Stainless steel, EPDM, Copper brazing (Heat exchanger), Silicone
Voltage V		3-phase 200 VAC/200 to 208 ±10 [%] (50/60 Hz)
Max. operating current A		26
Breaker capacity A		30 (Earth leakage breaker sensitivity current: 30 mA)
Communication function		Contact input/output (D-sub 25P, Female connector) Serial RS-485 (D-sub 9P, Female connector)
External dimensions mm		380 x 870 x 950
Weight*11 kg		175 ±5
Compliant standards		SEMI, CE/UKCA, UL

- *1 No condensation should be present.
- *2 GALDEN® is a registered trademark, belonging to the Solvay Group or its corresponding owner. Fluorinert™ is a trademark of 3M. Contact SMC when using a circulating fluid other than those listed in the table above.
- *3 Value with a stable load without turbulence in the operating conditions.
- *4 ① Facility water temperature: 25 °C, ② Circulating fluid flow rate: Values at the rated circulating fluid flow rate. Values common for 50/60 Hz.
- *5 The capacity at the thermo-chiller outlet when the circulating fluid temperature is 20 °C
- *6 The required flow rate for maintaining the cooling capacity or temperature stability. When used below the rated flow, use the individually sold, "Bypass Piping Set." (Refer to page 22).
- *7 May not be able to control with the set value depending on the piping specification in the user side.
- *8 Minimum volume required for operating only the thermo-chiller. (Circulating fluid temperature: 20 °C, including the thermo-chiller's internal pipings or heat exchanger)
- *9 Preliminary space volume without main tank capacity. Available for collecting the circulating fluid inside an external piping or for preliminary injection.
- *10 Facility water temperature: 25 °C. Flow rate required when the temperature setting is changed
- *11 Weight in the dry state without circulating fluids

Specifications (Ethylene Glycol Type)

Model		HRZC010-W1S		
Channel/Cooling method		1 channel/Water-cooled refrigeration		
Temperature control method		PID control		
Refrigerant		R744 (CO ₂ , GWP:1)		
Refrigerant charge		kg	1.0	
Installation environment	Ambient temperature	°C	10 to 35	
	Ambient humidity*1	%RH	30 to 70	
	Altitude	m	1000 or less	
Circulating fluid system	Circulating fluid*2		60 % ethylene glycol aqueous solution	
	Temperature range setting*1 / Temperature stability*3		°C	-20 to 90/±0.1
	Cooling capacity*4 (Under conditions below)		kW	10 (4)
	Circulating fluid temperature		°C	20 (-10)
	Facility water temperature		°C	25
	Circulating fluid flow rate		l/min	20
	Pump capacity*5		MPa	0.40 (at 20 l/min) With flow control, pressure control, and frequency control function by pump inverter
	Rated flow*6		l/min	20
	Flow display range		l/min	10 to 40
	Flow range*7		l/min	10 to 40
	Discharge pressure display range		MPa	0 to 1.5
	Tank	Main tank capacity*8	L	Approx. 15
		Sub-tank capacity*9	L	Approx. 16
	Contact material for circulating fluid		Stainless steel, EPDM, Copper brazing (Heat exchanger), Silicone, PPS, Fluororesin	
	Height difference between this product and user's equipment		m	10 or less
Outlet port size		Rc3/4 (With plug)		
Return port size		Rc3/4 (With plug)		
Drain port size		Rc3/8 (With valve/plug)		
Cooling water system	Temperature		°C	10 to 30
	Inlet pressure		MPa	0.3 to 0.7
	Inlet-outlet pressure differential of facility water		MPa	0.3 or more
	Required flow rate*10		l/min	15
	Inlet port size		Rc1/2 (With plug)	
	Outlet port size		Rc1/2 (With plug)	
Contact material for cooling water		Stainless steel, EPDM, Copper brazing (Heat exchanger), Silicone		
Electrical system	Voltage		V	3-phase 200 VAC/200 to 208 ±10 [%] (50/60 Hz)
	Max. operating current		A	25
	Breaker capacity		A	30 (Earth leakage breaker sensitivity current: 30 mA)
	Communication function		Contact input/output (D-sub 25P, Female connector) Serial RS-485 (D-sub 9P, Female connector)	
External dimensions		mm	380 x 870 x 950	
Weight*11		kg	175 ±5	
Compliant standards		SEMI, CE/UKCA, UL		

*1 No condensation should be present.

*2 Dilute pure ethylene glycol with tap water. Additives such as preservatives cannot be used.

*3 Value with a stable load without turbulence in the operating conditions. It may be out of this range when a DI control kit (Option Y) is used or in some other operating conditions.

*4 ① Facility water temperature: 25 °C, ② Circulating fluid flow rate: Values at the rated circulating fluid flow rate. Values common for 50/60 Hz.

*5 The capacity at the thermo-chiller outlet when the circulating fluid temperature is 20 °C

*6 The required flow rate for maintaining the cooling capacity or temperature stability. When used below the rated flow, use the individually sold, "Bypass Piping Set." (Refer to page 22).

*7 May not be able to control with the set value depending on the piping specification in the user side.

*8 Minimum volume required for operating only the thermo-chiller. (Circulating fluid temperature: 20 °C, including the thermo-chiller's internal pipings or heat exchanger)

*9 Preliminary space volume without main tank capacity. Available for collecting the circulating fluid inside an external piping or for preliminary injection.

*10 Facility water temperature: 25 °C. Flow rate required when the temperature setting is changed

*11 Weight in the dry state without circulating fluids

HRZC Series

Cooling Capacity

HRZC010-WS/W1S

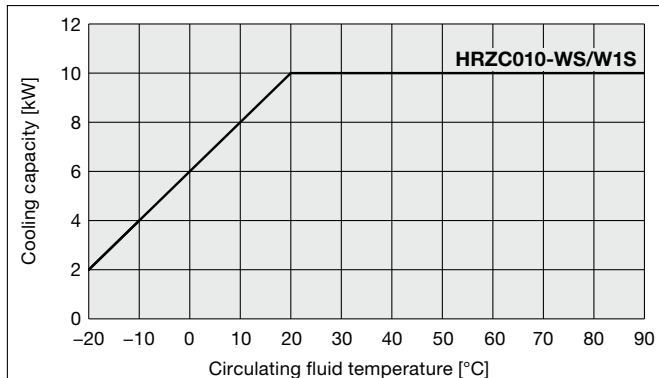

Heating Capacity

HRZC010-WS

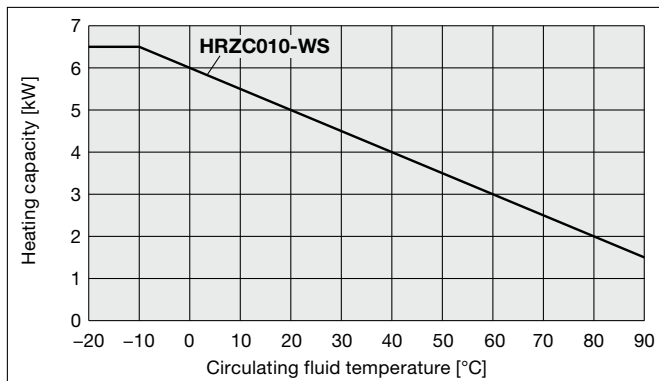

HRZC010-W1S

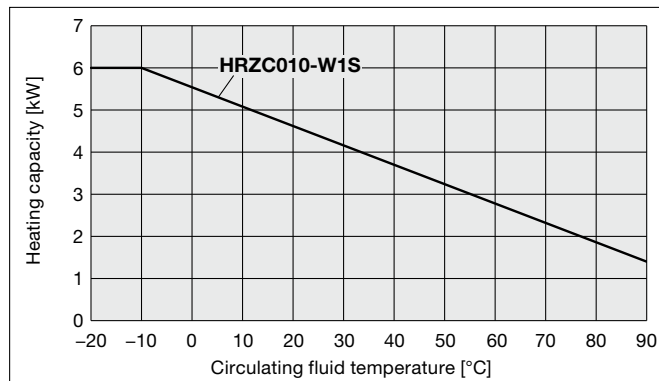

* When pump inverter is operating at frequency of 60 Hz (maximum).

Pump Capacity (Thermo-chiller Outlet)

HRZC010-WS

Circulating fluid: FC-3283

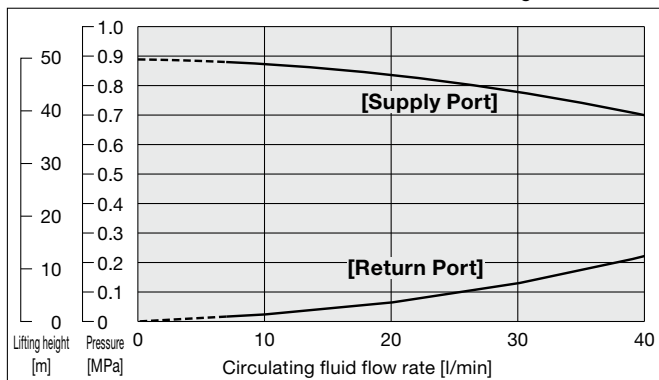

HRZC010-W1S

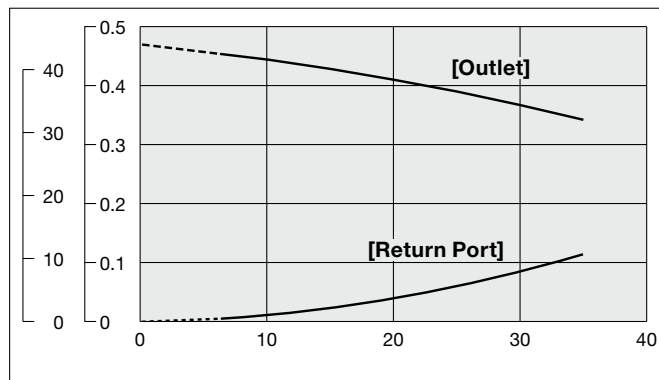

- * Circulating fluid temperature: 20 °C
- When the operation of the inverter is at maximum frequency
- * When the circulating fluid flow is below 6 l/min, the in-built operation stop alarm will be activated. It is not possible to run the equipment. (common for all models)
- * With flow control function by inverter

Dimensions

HRZC010-WS/HRZC010-W1S

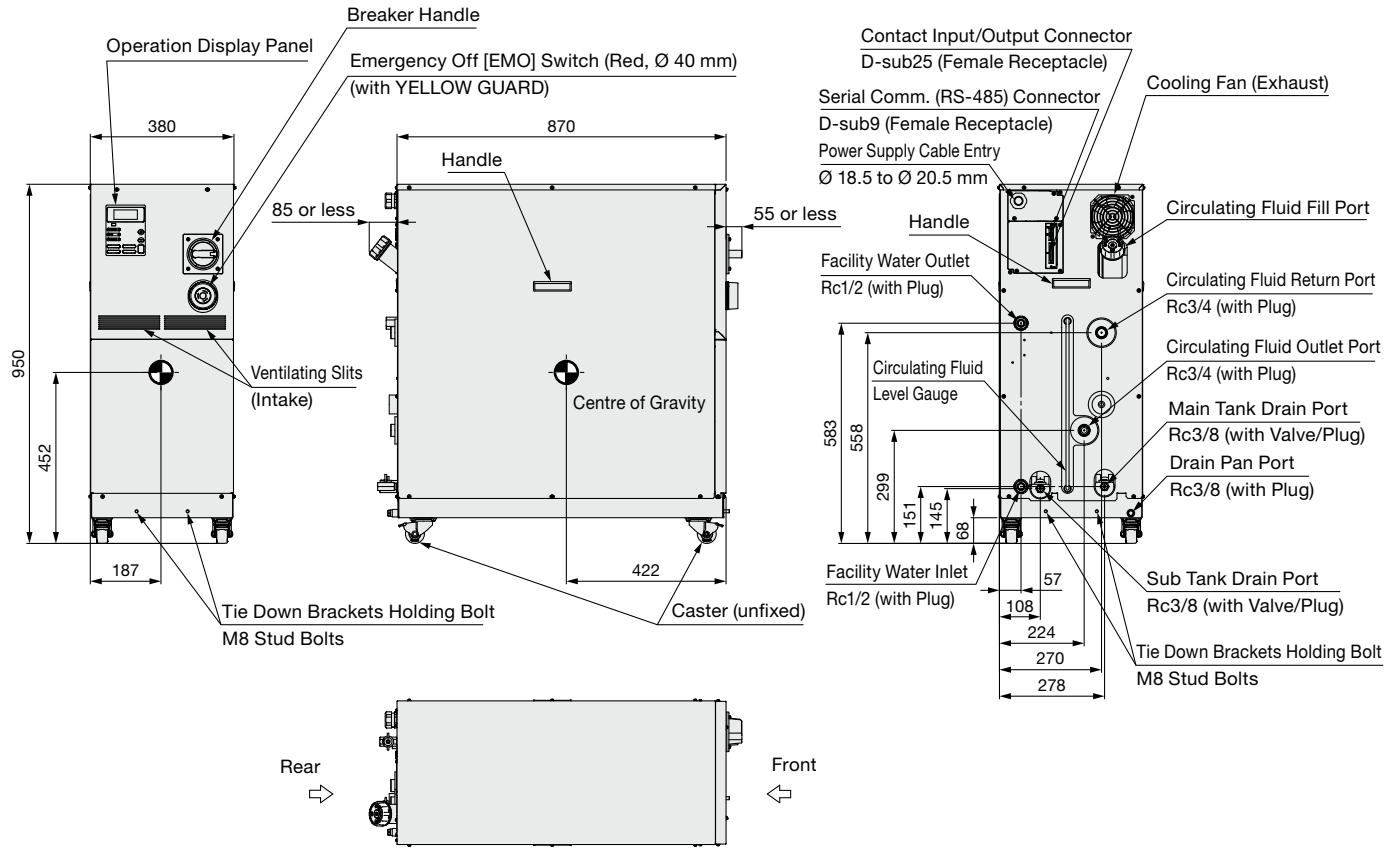

Communication Functions (For details, please refer to our "Communication Specifications" information.)

Contact Input/Output

Item		Specifications
Connector no.		P1
Connector type (on this product's side)		D-sub 25 P type, Female connector (M2.6 x 0.45 screw fixed type)
Input signal	Insulation method	Photocoupler
	Rated input voltage	24 VDC
	Rated input current	5 mA TYP
	Input impedance	4.7 kΩ
Contact output signal	Rated load voltage	48 VAC or less/30 VDC or less
	Maximum load current*1	800 mA AC/DC (Resistance load/Inductive load)

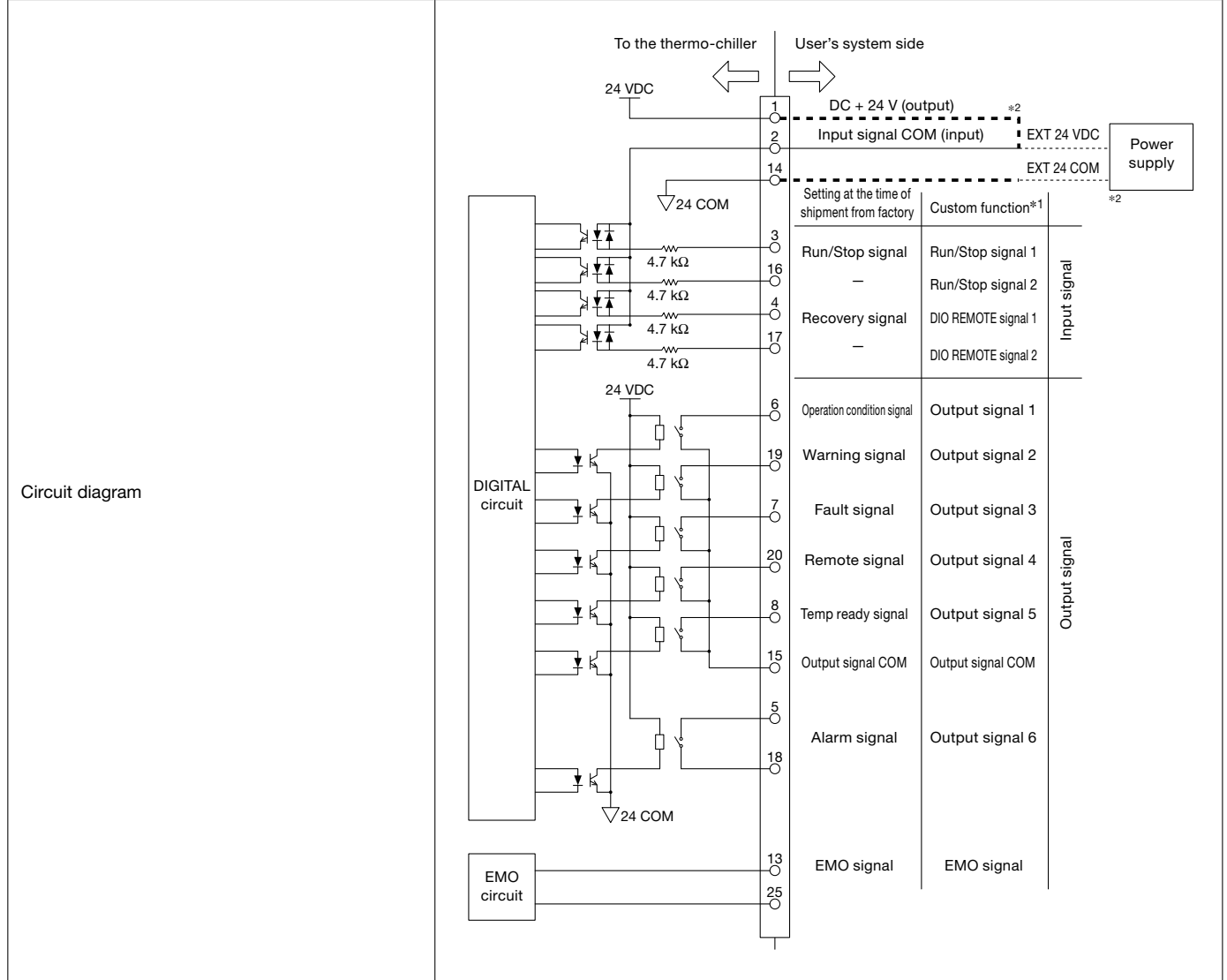

*1 When Common uses a common signal, the total load must be 800 mA or less.

*2 When the power supply of the thermo-chiller is used, connect pin No. 1 to pin No. 2, and the COM side of contact input signals to pin No. 14. When user's power supply is used, connect the + side of 24 VDC to pin No. 2 and connect the COM side of contact input signals to the COM of the user's system power supply. Incorrect connection leads to malfunction.

*3 The custom function is equipped for contact input/output. Using the custom function enables the user to set the signal type for contact input/output or pin assignment numbers. For details, please refer to the "Communication Specifications" information.

Serial RS-485

The serial RS-485 enables the following items to be written and read out.

<Writing>

Run/Stop

Circulating fluid temperature setting

Circulating fluid automatic recovery start/stop*1

<Readout>

Circulating fluid present temperature

Circulating fluid flow

Circulating fluid discharge pressure

Circulating fluid electric resistivity*2

Alarm occurrence information

Status (operating condition) information

*1 Only when the circulating fluid automatic recovery function (option Z) is selected.

*2 Only when the DI control kit (option Y) is selected.

Item	Specifications
Connector no.	P2
Connector type (on this product's side)	D-sub 9 P type, Female connector
Fixing bolt size	M2.6 x 0.45
Standards	EIA RS485
Protocol	Modicon Modbus

Circuit diagram	
Internal circuit	

Connector Location

Serial communication (RS-485) connector
D-sub 9 (Female receptacle)

Contact input/output communication connector
D-sub 25 (Female receptacle)

Power cable entry

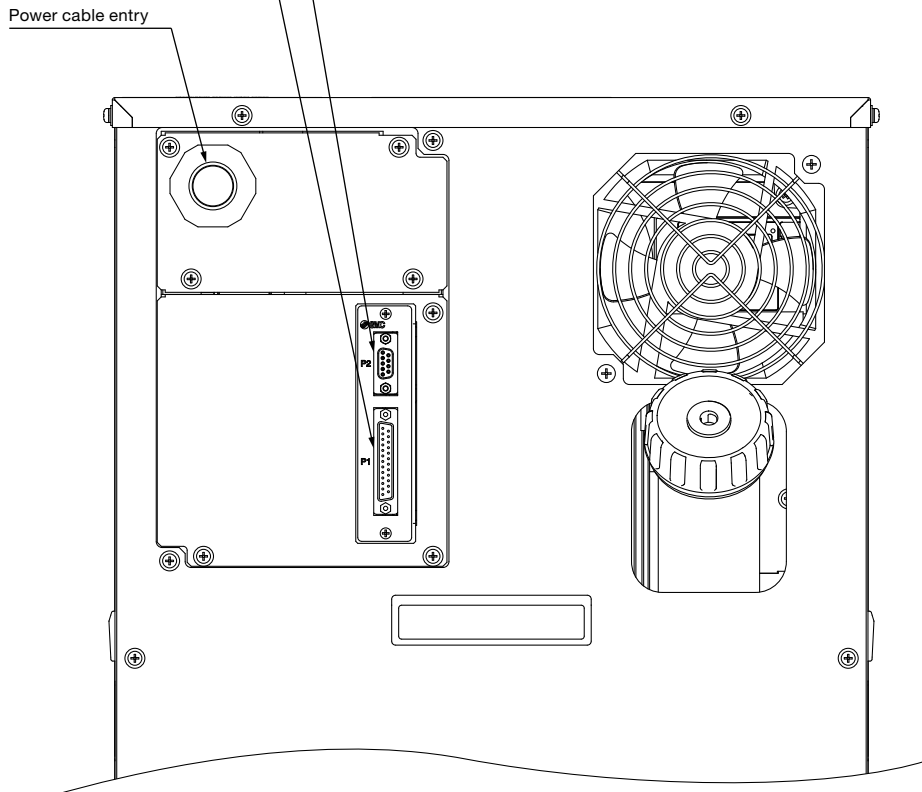

Rear side

HRZC Series

Operation Display Panel

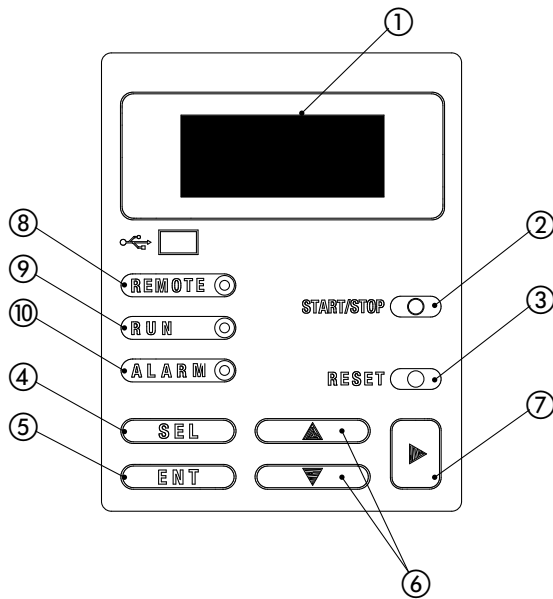

No.	Description	Function
①	LCD	Operating condition of this unit/Circulating fluid discharge temperature/Circulating fluid flow/Circulating fluid discharge pressure/Setting value/Alarm message, etc. are displayed.
②	[START/STOP] key	Starts/Stops the operation.
③	[RESET] key	Stops the alarm buzzing. Resets the alarm.
④	[SEL] key	Switches the display.
⑤	[ENT] key	Decides the settings.
⑥	[▲] [▼] key	Moves the cursor and changes the setting values.
⑦	[▶] key	Moves the cursor.
⑧	[REMOTE] lamp	Lights up when the unit is in the remote status.
⑨	[RUN] lamp	Lights up when the unit is in the operating status.
⑩	[ALARM] lamp	Lights up when the unit is alarming.

Alarm

This unit can display 27 kinds of alarm messages as standard. Also, it can read out the serial RS-485 communication.

Alarm code	Alarm message	Operation status	Main reason
01	Water Leak Detect FLT	Stop	Liquid deposits in the base of this unit.
03	RFGT High Press FLT	Stop	Pressure in the refrigeration circuit has exceeded the limitation.
04	CPRSR Overheat FLT	Stop	Temperature inside the compressor has increased.
05	Reservoir Low Level FLT	Stop	The amount of circulating fluid is running low.
06	Reservoir Low Level WRN	Continue	The amount of circulating fluid is running low.
07	Reservoir High Level WRN	Continue	Filling the circulating fluid too much.
08	Temp. Fuse Cutout FLT	Stop	Temperature of the circulating fluid tank is raised.
09	Reservoir High Temp. FLT	Stop	Temperature of the circulating fluid has exceeded the limitation.
10	Return High Temp. WRN	Continue	Temperature of returning circulating fluid has exceeded the limit.
11	Reservoir High Temp. WRN	Continue	Temperature of the circulating fluid has exceeded the limitation set by the user.
12	Return Low Flow FLT	Stop	The circulating fluid flow has gone below 6 l/min.
13	Return Low Flow WRN	Continue	The circulating fluid flow has gone below the limitation set by the user.
14	Heater Breaker Trip FLT	Stop	Protection device for the electric circuit of the heater is activated.
15	Pump Breaker Trip FLT	Stop	Protection device for the electric circuit of the circulating pump is activated.
16	CPRSR Breaker Trip FLT	Stop	Protection device for the electric circuit of the compressor is activated.
19	FAN Motor Stop WRN	Continue	Cooling fan inside the compressor has stopped.
20	Internal Pump Time Out WRN	Continue	The internal pump continuously run for more than a certain period of time.
21	Controller Error FLT	Stop	The error occurred in the control systems.
22	Memory Data Error FLT	Stop	The data stored in the controller of this unit went wrong.
23*2	Communication Error	Continue/Stop	The serial communications between this unit and user's system has been suspended.
24*1	DI Low Level WRN	Continue	DI level of the circulating fluid has gone below the limitation set by the user.
25	Pump Inverter Error FLT	Stop	An error has occurred in the inverter for the circulating pump.
27	F.Water High Temp. FLT	Stop	The facility water outlet temperature has exceeded the limit.
28	CPRSR INV Error FLT	Stop	An error has occurred in the inverter for the compressor.
29	RFGT Low Press FLT	Stop	The refrigerant pressure has gone below the limitation.
30	F.Water High Temp. WRN	Continue	The facility water outlet temperature has exceeded the limit set by the user.
32	Reservoir Low Temp. WRN	Continue	The temperature for circulating fluid return has gone below the limitation set by the user.

*1 Only for the DI control kit (option Y) specification

*2 Continue or stop can be selected.

HRZC Series Options

* Options have to be selected when ordering the thermo-chiller. It is not possible to add them after purchasing the unit.

C Option symbol Analogue Communication

HRZC010-□□-C
Analogue communication

In addition to the standard contact input/output signal communication and the serial RS-485 communication, analogue communication function can be added.

The analogue communication function enables to write and read out the following items.

<Writing>	<Readout>
Circulating fluid temperature setting	Circulating fluid present temperature
	Electric resistivity*1

*1 Only when the DI control kit (option Y) is selected.

Scaling voltage - circulating fluid temperature can be set arbitrarily by the customer.

For details, please refer to our "Communication Specifications" information.

D Option symbol DeviceNet Communication

HRZC010-□□-D
DeviceNet communication

DeviceNet
Trademark
 DeviceNet® is a registered trademark of ODVA, Inc.

In addition to the standard contact input/output signal communication and the serial RS-485 communication, DeviceNet function can be added. DeviceNet function enables to write and read out the following items.

<Writing>	<Readout>
Run/Stop	Circulating fluid present temperature
Circulating fluid temperature setting	Circulating fluid flow
Circulating fluid automatic recovery start/stop*1	Circulating fluid discharge pressure
	Electric resistivity*2
	Alarm occurrence information
	Status (operating condition) information

*1 Only when the circulating fluid automatic recovery function (Option Z) is selected.

*2 Only when the DI control kit (Option Y) is selected.

For details, please refer to our "Communication Specifications" information.

N Option symbol NPT Fitting

HRZC010-□□-N
NPT fitting

An adapter is included to change the connection parts of circulating fluid piping and facility water piping to NPT thread type. The adapter must be installed by the customer.

Y Option symbol DI Control Kit

HRZC010-W1S-Y
DI control kit

Select this option if you want to maintain the electric resistance ratio (DI level) of the circulating fluid at a certain level. However, some components have to be fitted by the customer. For details, refer to specification table for this option.

Please note that this is not applicable to the fluorinated liquid type.

DI circuit allowable circulating fluid	—	60 % ethylene glycol aqueous solution
DI level display range	MΩ·cm	0 to 20*1
DI level set range	MΩ·cm	0 to 2.0*2
Solenoid valve hysteresis or control	MΩ·cm	0 to 0.9
DI level reduction alarm set range	MΩ·cm	0 to 2.0
DI circuit rated flow	l/min	Approx. 1.5 (When the circulating fluid flow rate on the user's system side is 20 l/min)
Contact material for circulating fluid*3	—	FKM

*1 The DI level display value is the value without temperature correction.

*2 The DI filter is needed to control the DI level. (SMC Part No.: HRZ-DF001) Please purchase additionally because the DI filter is not included in this option. Also, if necessary, additionally purchase the insulating material for the DI filter. (SMC Part No.: HRZ-DF002)

*3 The additional contact material when this option is mounted

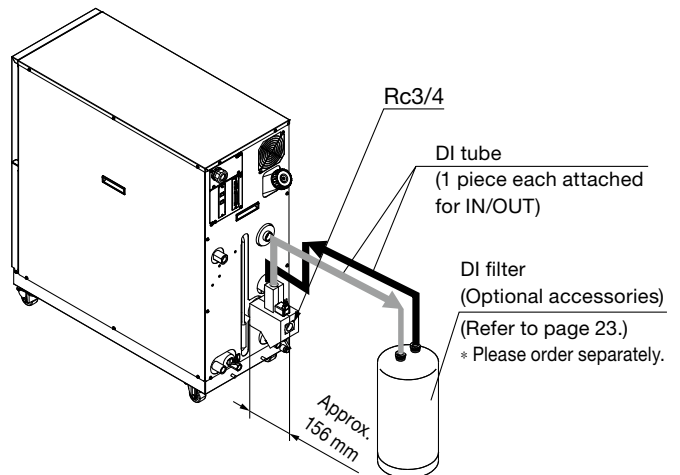

* Install the DI filter outside the thermo-chiller for piping. Secure the space for installing the DI filter on the rear side of the thermo-chiller.
 * It may go outside of the temperature stability range of $\pm 0.1^\circ\text{C}$ when this option is used in some operating conditions.

HRZC Series

Z Option symbol

Circulating Fluid Automatic Recovery

HRZC010-W□S-Z

Circulating fluid
automatic recovery

Select this option for users who want to use the circulating fluid automatic recovery function. The automatic recovery function is a device which can recover the circulating fluid inside pipings into a sub-tank of the thermo-chiller by the external communication or operating display panel. Some components need to be fitted by the customer. For details, please refer to the "Product Specifications" information for these options.

Circulating fluid recovery tank capacity*1	L	16
Purge gas	—	Nitrogen gas, Compressed air*2
Purge gas supply port	—	Self-align fitting for O.D. ø8*3
Purge gas supply pressure	MPa	0.4 to 0.7
Purge gas filtration	μm	0.01 or less
Regulator set pressure	MPa	0.15 to 0.3*4
Recoverable circulating fluid temperature	°C	10 to 30
Recovery operation	—	Serial RS-485, contact input/output, or operation display panel*5
Automatic recovery stop mode	sec	AUTO: After recovery completion, recovery is automatically stopped. (Factory setting) TIME: Recovery is continued for a set period of time. (Settable range: 1 to 600, Factory setting: 300)
Contact material for circulating fluid*6	—	FKM
Height difference with the user's system side	m	15 or less

*1 This is the preliminary space volume when the liquid level is "High." The main tank capacity is not included. Do not allow the amount of fluid in the external piping to exceed the capacity of the circulating fluid recovery tank.

*2 Use compressed air with a dew point of -30 °C or less. If compressed air with a high dew point is used, condensation will be generated in the tank when operated at low temperatures, which may result in cooling failure and other malfunctions. Be sure to confirm that there are no chemicals, synthetic oils that include organic solvents, salt, corrosive gases, etc., in the compressed air. In addition, if a lubricator is used on the compressed air supply side, the bleed hole of the regulator may become clogged, resulting in malfunction.

*3 Before piping, clean inside the pipings with air blow, etc. Use the piping with no dust generation by purge gas. When using resin tube, where necessary, use insert fittings, etc. in order not to deform the tubings when connecting to self-align fittings.

*4 At the time of shipping from factory, it is set to 0.2 MPa.

*5 Refer to the thermo-chiller operation manual and the communication specifications manual for details.

*6 The additional contact material when this option is mounted

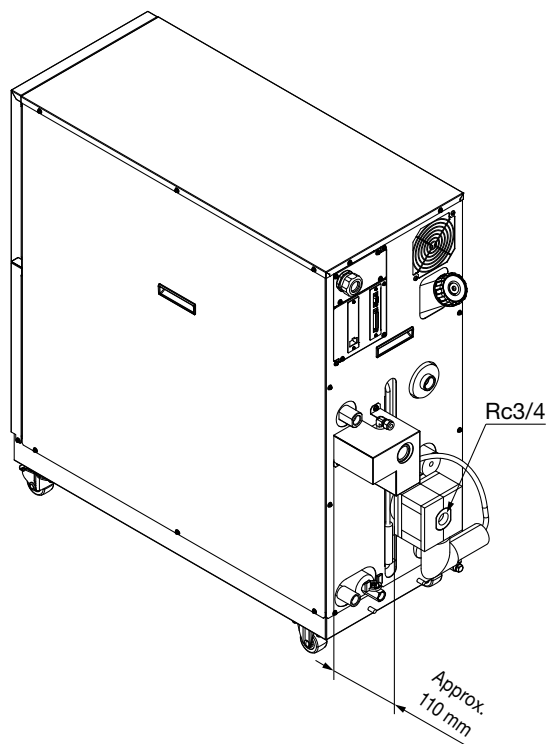

HRZC Series Optional Accessories

① Bypass Piping Set

* Necessary to be fitted by user.

When the circulating fluid goes below the rated flow, cooling capacity will be reduced and the temperature stability will be badly affected. In such a case, use the bypass piping set.

Part no.	Applicable model
HRZ-BP002	Common for all models

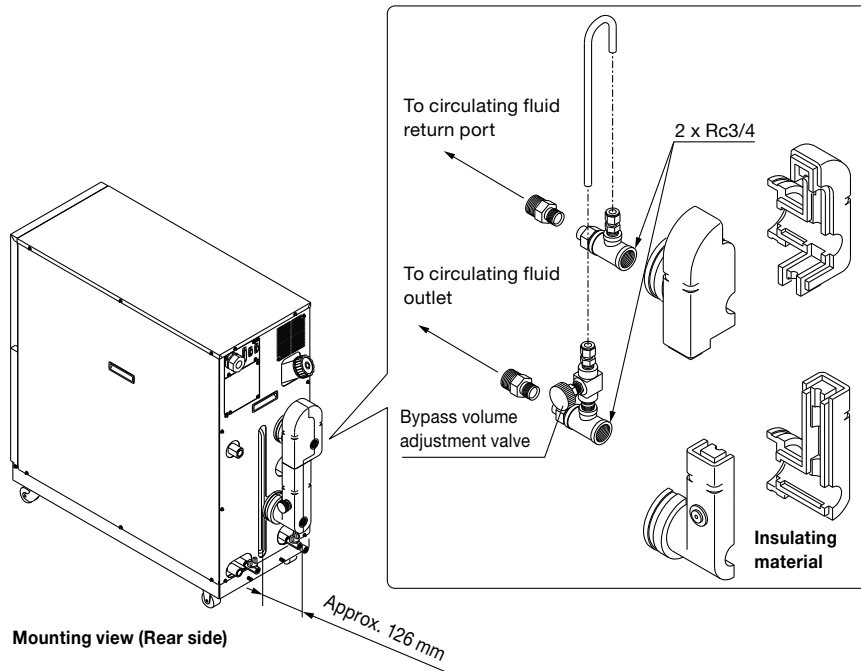

② Anti-quake Bracket

Bracket for earthquakes
Prepare the anchor bolts (M12) which are suited to the floor material by the customer.

Part no.	Applicable model
HRZ-TK002	Common for all models

* 2 pieces per set (for 1 unit) (HRZ-TK002)

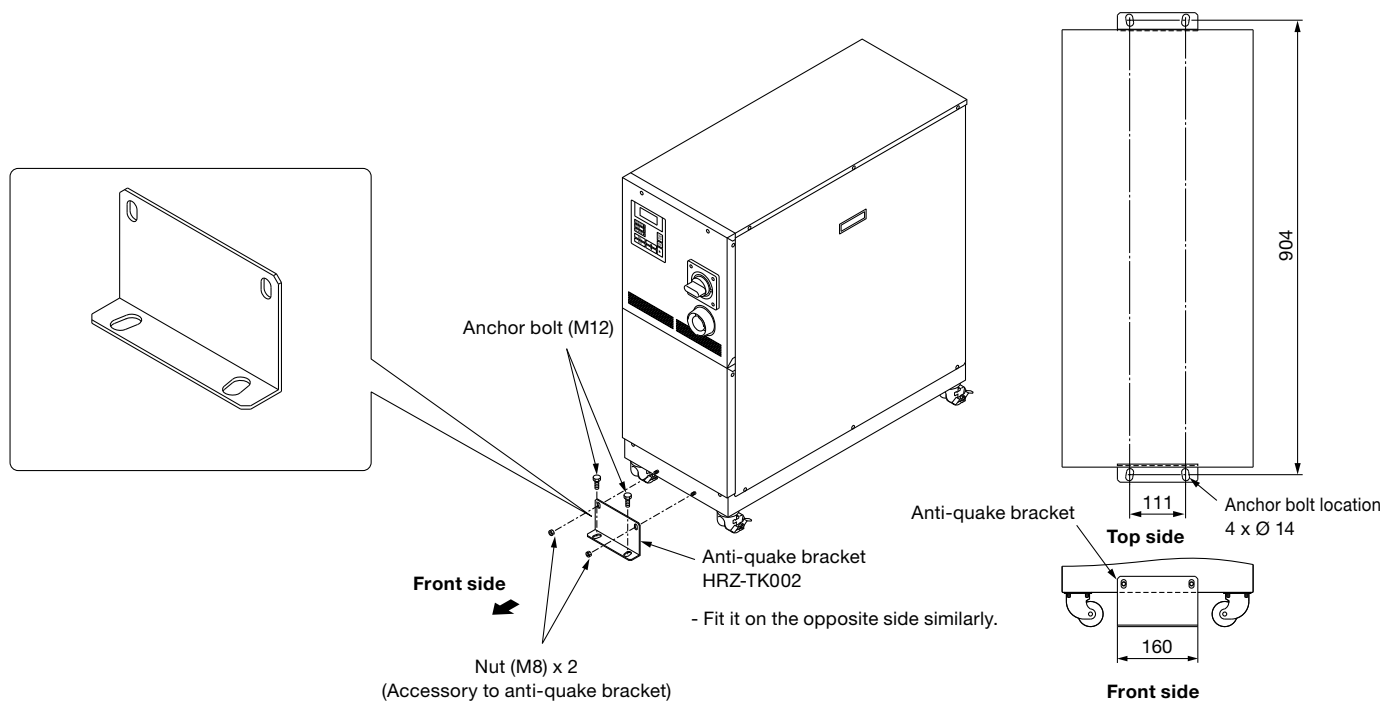

HRZC Series

③ 4-Port Manifold

4-branching the circulating fluid enables 4 temperature controls at the maximum with the 1 unit thermo-chiller.

Part no.	Applicable model
HRZ-MA001	Common for all models

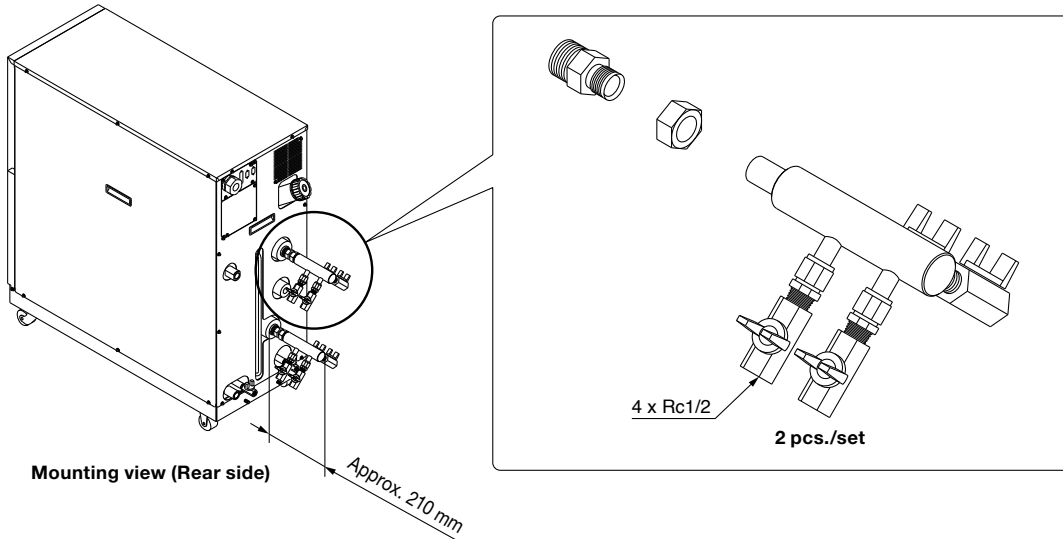

④ DI Filter

This is the ion replacement resin to maintain the electric resistivity of the circulating fluid. Users who selected the DI control kit (Option Y) need to purchase the DI filter separately.

Part no.	Applicable model
HRZ-DF001	HRZC010-W1S-Y

* The DI filters are consumable. Depending on the status (electric resistivity set value, circulating fluid temperature, piping volume, etc.), product life cycles will vary accordingly.

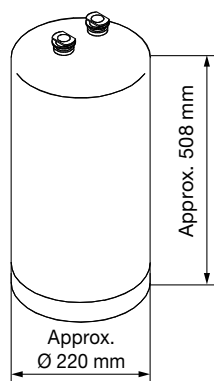

Weight: Approx. 20 kg

⑤ Insulating Material for DI Filter

When the DI filter is used at a high-temperature, we recommend that you use this insulating material to protect the radiated heat from the DI filter or possible burns. When the DI filter is used at a low-temperature, we also recommend that you use this to prevent heat absorption from the DI filter and to avoid forming condensation.

Part no.	Applicable model
HRZ-DF002	HRZC010-W1S-Y

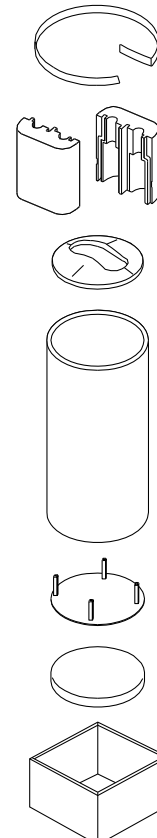

⑥ 60 % Ethylene Glycol Aqueous Solution

This solution can be used as a circulating fluid for ethylene glycol-type thermo-chillers. (Capacity: 10 L)

Part no.	Applicable model
HRZ-BR001	HRZC010-W1S

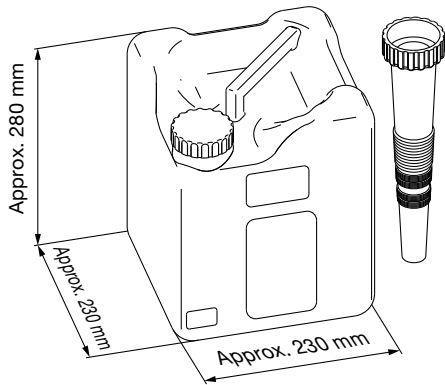

⑦ Concentration Meter

This meter can be used to control the condensation of ethylene glycol solution regularly.

Part no.	Applicable model
HRZ-BR002	HRZC010-W1S

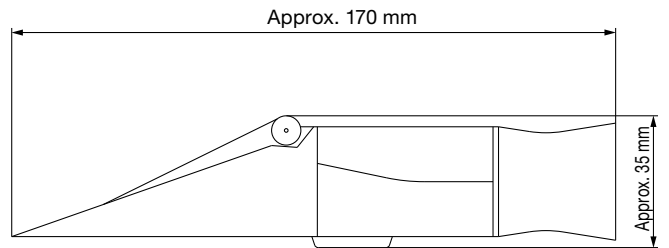



HRZC Series Specific Product Precautions 1

Be sure to read this before handling the products. Refer to the back cover for safety instructions. For temperature control equipment precautions, refer to the “Handling Precautions for SMC Products” and the “Operation Manual” on the SMC website: <https://www.smc.eu>

Design

Warning

- This catalogue shows the specifications of a single unit.
 - For details, please refer to our “Product Specifications” and thoroughly consider the adaptability between the user’s system and this unit.
 - Although a protection circuit as a single unit is installed, the user is requested to carry out a safety design for the whole system.

Facility Water Supply

Warning

<Water-cooled refrigeration>

- The water-cooled refrigeration type thermo-chiller radiates heat to the facility water. Prepare the facility water system that satisfies the facility water specifications below.
- When using tap water as facility water, SMC recommends the water quality shown in the following table as reference.

<Tap Water (as Facility Water) Quality Standards>

The Japan Refrigeration and Air Conditioning Industry Association
JRA GL-02-1994 “Cooling water system – Circulation type – Circulating water”

	Item	Unit	Standard value	Influence	
				Corrosion	Scale generation
Standard item	pH (at 25 °C)	—	6.5 to 8.2	○	○
	Electric conductivity (25 °C)	[μS/cm]	100*1 to 800*1	○	○
	Chloride ion (Cl ⁻)	[mg/L]	200 or less	○	
	Sulfuric acid ion (SO ₄ ²⁻)	[mg/L]	200 or less	○	
	Acid consumption amount (at pH4.8)	[mg/L]	100 or less		○
	Total hardness	[mg/L]	200 or less		○
	Calcium hardness (CaCO ₃)	[mg/L]	150 or less		○
Reference item	Ionic state silica (SiO ₂)	[mg/L]	50 or less		○
	Iron (Fe)	[mg/L]	1.0 or less	○	○
	Copper (Cu)	[mg/L]	0.3 or less	○	
	Sulfide ion (S ₂ ⁻)	[mg/L]	Should not be detected.	○	
	Ammonium ion (NH ₄ ⁺)	[mg/L]	1.0 or less	○	
	Residual chlorine (Cl)	[mg/L]	0.3 or less	○	
	Free carbon (CO ₂)	[mg/L]	4.0 or less	○	

*1 In the case of [MΩ·cm], it will be 0.001 to 0.01.

- : Factors that have an effect on corrosion or scale generation.
- Even if the water quality standards are met, complete prevention of corrosion is not guaranteed.

- Set the supply pressure between 0.3 to 0.7 MPa. Ensure a pressure difference at the facility water inlet/outlet of 0.3 MPa or more.

If the supply pressure is high, it will cause water leakage. If the supply pressure and pressure difference at the facility water inlet/outlet is low, it will cause an insufficient flow rate of the facility water, and poor temperature control.

Transportation / Carriage / Movement

Warning

1. Transporting with forklift

- It is not possible to hang this product.
- The fork insertion position is either on the left side face or right side face of the unit. Be careful not to bump the fork against a caster and be sure to put through the fork to the opposite side.
- Be careful not to bump the fork to the cover panel or piping ports.

2. Transporting with casters

- This product is heavy and should be moved by at least two people.
- Do not grip the pipings on the rear side or the handles of the panel.

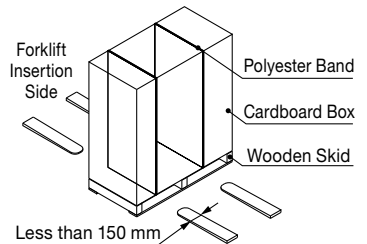

<When Packaged>

Model	Weight [kg]	Dimensions [mm] (Width x Depth x Height)
HRZC010-W□S	205	570 x 1200 x 1265

Mounting / Installation

Caution

- Avoid using this product outdoors.
- Install on a rigid floor which can withstand this product’s weight.
- Install a suitable anchor bolt for the anti-quake bracket taking into consideration the user’s floor material.
- Avoid placing heavy objects on this product.



HRZC Series

Specific Product Precautions 2

Be sure to read this before handling the products. Refer to the back cover for safety instructions. For temperature control equipment precautions, refer to the “Handling Precautions for SMC Products” and the “Operation Manual” on the SMC website: <https://www.smc.eu>

Piping

Caution

- 1. The circulating fluid and facility water piping should be prepared by user with consideration of the operating pressure, temperature, and circulating fluid/facility compatibility.**

If the operating performance is not sufficient, the pipings may burst during operation. Also, the use of corrosive materials such as aluminium or iron for fluid contact parts, such as piping, may not only lead to clogging or leakage in the circulating fluid and facility water circuits but also refrigerant leakage and other unexpected problems. Provide protection against corrosion when you use the product.

- 2. The surface of the circulating fluid pipings should be covered with the insulating materials which can effectively confine the heat.**

Absorbing the heat from the surface of pipings may reduce the cooling capacity performance and the heating capacity may be shortened due to heat radiation.

- 3. When using fluorinated liquid as the circulating fluid, do not use pipe tape.**

Liquid leakage may occur around the pipe tape.
For sealant, we recommend that you use the following sealant:
SMC Part No., HRZ-S0003 (Silicone sealant)

- 4. For the circulating fluid pipings, use clean pipings which have no dust, oil or water moisture inside the pipings, and blow with air prior to undertaking any piping works.**

If any dust, oil or water moisture enters the circulating fluid circuit, inferior cooling performance or equipment failure due to frozen water may occur, resulting in bubbles in the circulating fluid inside the tank.

- 5. The reciprocating total volume of the circulating fluid pipings must be less than the volume of the sub-tank.**

Otherwise, when the equipment is stopped, the in-built alarm may activate or the circulating fluid may leak from the tank. Refer to the specifications table for the sub-tank volume.

- 6. Select the circulating fluid pipings which can exceed the required rated flow.**

For the rated flow, refer to the pump capacity table.

- 7. For the circulating fluid piping connection, install a drain pan just in case the circulating fluid may leak.**

- 8. Do not return the circulating fluid to the unit by installing a pump in the user's system.**

- 9. The facility water flow rate is adjusted automatically according to the operating conditions. In addition, the facility water return temperature is 60 °C at maximum.**

Safety Instructions

These safety instructions are intended to prevent hazardous situations and/or equipment damage. These instructions indicate the level of potential hazard with the labels of “Caution,” “Warning” or “Danger.” They are all important notes for safety and must be followed in addition to International Standards (ISO/IEC)¹⁾, and other safety regulations.

Danger:

Danger indicates a hazard with a high level of risk which, if not avoided, will result in death or serious injury.

Warning:

Warning indicates a hazard with a medium level of risk which, if not avoided, could result in death or serious injury.

Caution:

Caution indicates a hazard with a low level of risk which, if not avoided, could result in minor or moderate injury.

- 1) ISO 4414: Pneumatic fluid power – General rules and safety requirements for systems and their components.
ISO 4413: Hydraulic fluid power – General rules and safety requirements for systems and their components.
IEC 60204-1: Safety of machinery – Electrical equipment of machines. (Part 1: General requirements)
ISO 10218-1: Robots and robotic devices - Safety requirements for industrial robots - Part 1: Robots.
etc.

Warning

1. The compatibility of the product is the responsibility of the person who designs the equipment or decides its specifications.

Since the product specified here is used under various operating conditions, its compatibility with specific equipment must be decided by the person who designs the equipment or decides its specifications based on necessary analysis and test results. The expected performance and safety assurance of the equipment will be the responsibility of the person who has determined its compatibility with the product. This person should also continuously review all specifications of the product referring to its latest catalogue information, with a view to giving due consideration to any possibility of equipment failure when configuring the equipment.

2. Only personnel with appropriate training should operate machinery and equipment.

The product specified here may become unsafe if handled incorrectly. The assembly, operation and maintenance of machines or equipment including our products must be performed by an operator who is appropriately trained and experienced.

3. Do not service or attempt to remove product and machinery/equipment until safety is confirmed.

1. The inspection and maintenance of machinery/equipment should only be performed after measures to prevent falling or runaway of the driven objects have been confirmed.
2. When the product is to be removed, confirm that the safety measures as mentioned above are implemented and the power from any appropriate source is cut, and read and understand the specific product precautions of all relevant products carefully.
3. Before machinery/equipment is restarted, take measures to prevent unexpected operation and malfunction.

4. Our products cannot be used beyond their specifications. Our products are not developed, designed, and manufactured to be used under the following conditions or environments. Use under such conditions or environments is not covered.

1. Conditions and environments outside of the given specifications, or use outdoors or in a place exposed to direct sunlight.
2. Use for nuclear power, railways, aviation, space equipment, ships, vehicles, military application, equipment affecting human life, body, and property, fuel equipment, entertainment equipment, emergency shut-off circuits, press clutches, brake circuits, safety equipment, etc., and use for applications that do not conform to standard specifications such as catalogues and operation manuals.
3. Use for interlock circuits, except for use with double interlock such as installing a mechanical protection function in case of failure. Please periodically inspect the product to confirm that the product is operating properly.

Caution

We develop, design, and manufacture our products to be used for automatic control equipment, and provide them for peaceful use in manufacturing industries.

Use in non-manufacturing industries is not covered.

Products we manufacture and sell cannot be used for the purpose of transactions or certification specified in the Measurement Act.

The new Measurement Act prohibits use of any unit other than SI units in Japan.

Limited warranty and Disclaimer/Compliance Requirements

The product used is subject to the following “Limited warranty and Disclaimer” and “Compliance Requirements”. Read and accept them before using the product.

Limited warranty and Disclaimer

1. The warranty period of the product is 1 year in service or 1.5 years after the product is delivered, whichever is first.²⁾ Also, the product may have specified durability, running distance or replacement parts. Please consult your nearest sales branch.
2. For any failure or damage reported within the warranty period which is clearly our responsibility, a replacement product or necessary parts will be provided. This limited warranty applies only to our product independently, and not to any other damage incurred due to the failure of the product.
3. Prior to using SMC products, please read and understand the warranty terms and disclaimers noted in the specified catalogue for the particular products.
- 2) Vacuum pads are excluded from this 1 year warranty.
A vacuum pad is a consumable part, so it is warranted for a year after it is delivered. Also, even within the warranty period, the wear of a product due to the use of the vacuum pad or failure due to the deterioration of rubber material are not covered by the limited warranty.

Compliance Requirements

1. The use of SMC products with production equipment for the manufacture of weapons of mass destruction (WMD) or any other weapon is strictly prohibited.
2. The exports of SMC products or technology from one country to another are governed by the relevant security laws and regulations of the countries involved in the transaction. Prior to the shipment of a SMC product to another country, assure that all local rules governing that export are known and followed.

Safety Instructions

Be sure to read “Handling Precautions for SMC Products” (M-E03-3) before using.

SMC Corporation (Europe)

Austria	+43 (0)2262622800	www.smc.at	office@smc.at
Belgium	+32 (0)33551464	www.smc.be	info@smc.be
Bulgaria	+359 (0)2807670	www.smc.bg	office@smc.bg
Croatia	+385 (0)13707288	www.smc.hr	office@smc.hr
Czech Republic	+420 541424611	www.smc.cz	office@smc.cz
Denmark	+45 70252900	www.smc.dk.com	smc@smcdk.com
Estonia	+372 651 0370	www.smcee.ee	info@smcee.ee
Finland	+358 207513513	www.smc.fi	smcfi@smc.fi
France	+33 (0)164761000	www.smc-france.fr	supportclient@smc-france.fr
Germany	+49 (0)61034020	www.smc.de	info@smc.de
Greece	+30 210 2717265	www.smchellas.gr	sales@smchellas.gr
Hungary	+36 23513000	www.smc.hu	office@smc.hu
Ireland	+353 (0)14039000	www.smcautomation.ie	sales@smcautomation.ie
Italy	+39 03990691	www.smcitalia.it	mailbox@smcitalia.it
Latvia	+371 67817700	www.smc.lv	info@smc.lv

Lithuania	+370 5 2308118	www.smclt.lt	info@smclt.lt
Netherlands	+31 (0)205318888	www.smc.nl	info@smc.nl
Norway	+47 67129020	www.smc-norge.no	post@smc-norge.no
Poland	+48 222119600	www.smc.pl	sales@smc.pl
Portugal	+351 214724500	www.smc.eu	apoioclientept@smc.smces.es
Romania	+40 213205111	www.smcromania.ro	smcromania@smcromania.ro
Russia	+7 (812)3036600	www.smc.eu	sales@smcru.com
Slovakia	+421 (0)413213212	www.smc.sk	office@smc.sk
Slovenia	+386 (0)73885412	www.smc.si	office@smc.si
Spain	+34 945184100	www.smc.eu	post@smc.smces.es
Sweden	+46 (0)86031240	www.smc.nu	smc@smc.nu
Switzerland	+41 (0)523963131	www.smc.ch	info@smc.ch
Turkey	+90 212 489 0 440	www.smcturkey.com.tr	info@smcturkey.com.tr
UK	+44 (0)845 121 5122	www.smc.uk	sales@smc.uk

South Africa +27 10 900 1233 www.smcza.co.za zasales@smcza.co.za