

Circulating Fluid Temperature Controller

**Low GWP Refrigerant Chiller**

New



RoHS

**Thermo-chiller** Standard Type

**GWP:146**<sup>\*1</sup>

EU refrigerant regulations: GWP150 or more  
US refrigerant regulations: GWP700 or more  
California, US refrigerant regulations: GWP750 or more

\*1 Regulation (EU) 2024/573, AIM Act 40 CFR Part 84

Environmentally friendly **R454C** as refrigerant

Not available for air transport

**No heater is required, as the circulating fluid is heated using only the heat exhausted by the refrigerating circuit.**

■ Heating-up time: 1/10

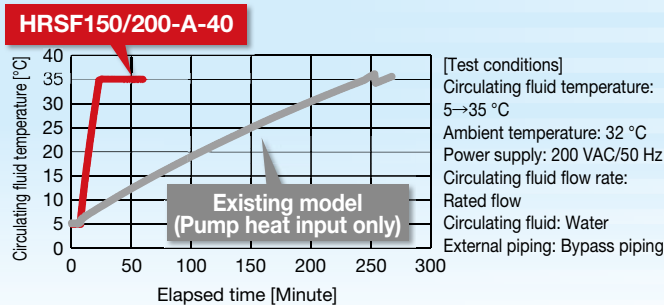

Cooling valve control

Air-cooled condenser fan

Heating valve control

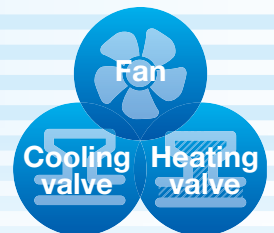

Cooling capacity **15 kW/20 kW**

Temperature stability **±0.1 °C**  
(When a load is stable)

Set temperature range **5 °C to 35 °C**

Low-noise design **70 dB(A)**



Outdoor installation **IPX4**

Compatible with power supplies in Europe, Asia, Oceania, and North, Central, and South America

• 3-phase 400 VAC

**HRSF150/200 Series**



CAT.EUS40-79A-UK

# CONTENTS

## HRSF150/200 Series **Standard Type**



### Circulating Fluid Temperature Controller

#### **Low GWP Refrigerant Chiller** Thermo-chiller HRSF150/200 Series

##### How to Order/Specifications

**Air-cooled 400 V** ..... p. 2

**Water-cooled 400 V** ..... p. 3

Cooling Capacity ..... p. 4

Pump Capacity ..... p. 4

Dimensions ..... p. 5

##### ● **Options**

With Caster Adjuster-foot ..... p. 7

With Fluid Fill Port ..... p. 7

Applicable to Deionised Water Piping ..... p. 8

##### ● **Optional Accessories**

① Piping Conversion Fitting ..... p. 9

② Caster Adjuster-foot Kit ..... p. 9

③ Electric Conductivity Control Set ..... p. 10

④ Bypass Piping Set ..... p. 10

⑤ Snow Protection Hood ..... p. 11

⑥ Particle Filter Set ..... p. 12

⑦ Wired Remote Controller ..... p. 13

##### ● **Cooling Capacity Calculation**

Required Cooling Capacity Calculation ..... p. 14

Precautions on Cooling Capacity Calculation ..... p. 15

Circulating Fluid Typical Physical Property Values ..... p. 15

Specific Product Precautions ..... p. 16

# Low GWP Refrigerant Chiller



# Thermo-chiller Standard Type

## Air-cooled 400 V Type

### HRSF150/200 Series



### How to Order

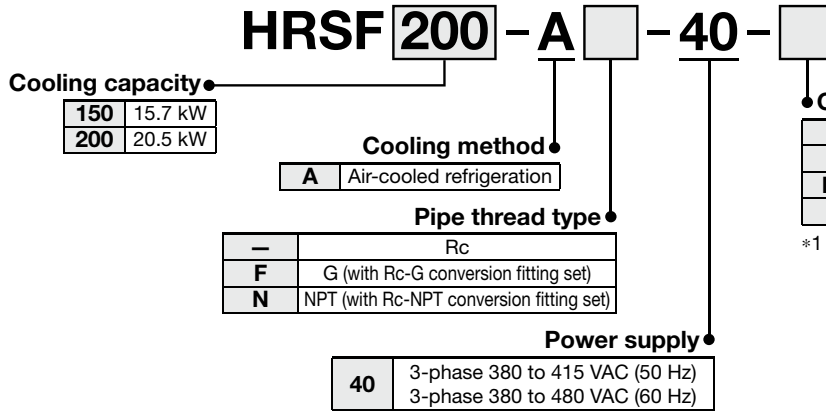

**Option**

-	None
A	With caster adjuster-foot
K*1	With fluid fill port
M	Applicable to DI water piping

\*1 This is a manual fluid fill port that is different from the automatic fluid fill port. Fluid can be supplied manually into the tank without removing the side panel. (Fluid can be supplied manually for models without option K if the side panel is removed.)

### Specifications

Model		HRSF150-A□-40-□	HRSF200-A□-40-□	
<b>Cooling method</b>		Air-cooled refrigeration		
<b>Refrigerant</b>		R454C (HFO/HFC, GWP: 146)*10		
<b>Refrigerant charge</b>	kg	1.5	1.5	
<b>Control method</b>		PID control		
<b>Ambient temperature</b> *1,8		-20 to 45 °C		
<b>Circulating fluid system</b>	<b>Circulating fluid</b> *1,2			
	Tap water, 15 to 40 % Ethylene glycol aqueous solution, Deionised water			
	<b>Set temperature range</b> *1	°C		
	5 to 35			
	<b>Cooling capacity</b> *3,8	15.7	20.5	
	<b>Heating capacity</b> *4	3	5.5	
	<b>Temperature stability</b> *5	°C		
	±0.1			
	<b>Pump capacity</b>	<b>Rated flow (Outlet)</b>	l/min	
		45 (0.45 MPa)		
		<b>Maximum flow rate</b>	l/min	
	130			
	<b>Maximum pump head</b>	m		
	50			
	<b>Settable pressure range</b> *6	MPa		
0.1 to 0.5				
<b>Minimum operating flow rate</b> *7	25	35		
<b>Tank capacity</b>	L			
42				
<b>Circulating fluid outlet, circulating fluid return port</b>				
Rc1 (Symbol F: G1, Symbol N: NPT1)				
<b>Tank drain port</b>				
Rc3/4 (Symbol F: G3/4, Symbol N: NPT3/4)				
<b>Automatic fluid fill system (Standard)</b>	<b>Supply side pressure range</b>	MPa		
		0.2 to 0.5		
	<b>Supply side fluid temperature</b>	°C		
		5 to 35		
<b>Automatic fluid fill port</b>				
Rc1/2 (Symbol F: G1/2, Symbol N: NPT1/2)				
<b>Overflow port</b>				
Rc1 (Symbol F: G1, Symbol N: NPT1)				
<b>Fluid contact material</b>	<b>Metal</b>	Stainless steel, Copper (Heat exchanger brazing), Brass, Bronze		
	<b>Resin</b>	PTFE, PU, FKM, EPDM, PVC, NBR, POM, PE, NR		
<b>Electrical system</b>	<b>Power supply</b>			
	3-phase 380 to 415 VAC (50 Hz) Allowable voltage range ±10 % (No continuous voltage fluctuation)			
	3-phase 380 to 480 VAC (60 Hz) Allowable voltage range +4 %, -10 % (Max. voltage less than 500 V and no continuous voltage fluctuation)			
	<b>Earth leakage breaker (Standard)</b>	<b>Rated current</b>	A	
	30			
	<b>Sensitivity of leak current</b>	mA		
30				
<b>Rated operating current</b> *5	A	13.1	16.9	
<b>Rated power consumption</b> *5	kW (kVA)	8.0 (9.0)	10.8 (11.7)	
<b>Noise level (Front 1 m/Height 1 m)</b> *5	dB (A)	68		
<b>Waterproof specification</b>				
IPX4				
<b>Accessories</b>				
Alarm code list stickers 2 pcs. (English 1 pc./Japanese 1 pc.), Operation Manual (for installation/operation) 2 pcs. (English 1 pc./Japanese 1 pc.), Y-strainer (40 meshes) 25A, Barrel nipple 25A, Anchor bolt fixing brackets 2 pcs. (including 6 M8 bolts)*9				
<b>Weight (dry state)</b>	kg	230		

\*1 When the ambient temperature or circulating fluid temperature is 10 °C or below, use ethylene glycol aqueous solution.  
 \*2 Use fluid in condition below as the circulating fluid.  
 Tap water: Standard of The Japan Refrigeration And Air Conditioning Industry Association (JRA GL-02-1994)  
 For the concentration of the ethylene glycol aqueous solution, refer to the operation manual.  
 Deionised water: Electric conductivity 1 μS/cm or higher (Electric resistivity 1 MΩ·cm or lower)  
 \*3 ① Ambient temperature: 32 °C, ② Circulating fluid: Tap water, ③ Circulating fluid temperature: 20 °C, ④ Circulating fluid flow rate: Rated flow, ⑤ Power supply: 400 VAC  
 \*4 ① Ambient temperature: 32 °C, ② Circulating fluid: Tap water, ③ Circulating fluid flow rate: Rated flow, ④ Power supply: 400 VAC  
 \*5 ① Ambient temperature: 32 °C, ② Circulating fluid: Tap water, ③ Circulating fluid temperature: 20 °C, ④ Load: Same as the cooling capacity, ⑤ Circulating fluid flow rate: Rated flow, ⑥ Power supply: 400 VAC, ⑦ Piping length: Shortest  
 \*6 With the pressure control mode by inverter. When the pressure control mode is not used, the pump power frequency set mode can be used.  
 \*7 Fluid flow rate to maintain the cooling capacity. If the actual flow rate is lower than this, install a bypass piping.  
 \*8 If the product is used at an altitude of 1000 meters or higher, the maximum allowable ambient temperature and the cooling capacity decrease. For details, refer to the operation manual.  
 \*9 The anchor bolt fixing brackets (including 6 M8 bolts) are used for fixing to wooden skids when packaging the thermo-chiller. No anchor bolt is included.  
 \*10 R454C is a slightly flammable refrigerant. Avoid using this product in proximity to open flames.

# Low GWP Refrigerant Chiller



RoHS

# Thermo-chiller Standard Type

## Water-cooled 400 V Type

### HRSF150/200 Series



### How to Order

**HRSF 200 - W - 40 -**

**Cooling capacity**

150	15.7 kW
200	20.6 kW

**Cooling method**

W	Water-cooled refrigeration
---	----------------------------

**Pipe thread type**

-	Rc
F	G (with Rc-G conversion fitting set)
N	NPT (with Rc-NPT conversion fitting set)

**Power supply**

40	3-phase 380 to 415 VAC (50 Hz) 3-phase 380 to 480 VAC (60 Hz)
----	--

**Option**

-	None	K*1	With fluid fill port
A	With caster adjuster-foot	M	Applicable to DI water piping

\*1 This is a manual fluid fill port that is different from the automatic fluid fill port. Fluid can be supplied manually into the tank without removing the side panel. (Fluid can be supplied manually for models without option K if the side panel is removed.)

### Specifications

Model		HRSF150-W□-40-□	HRSF200-W□-40-□	
<b>Cooling method</b>		Water-cooled refrigeration		
<b>Refrigerant</b>		R454C (HFO/HFC, GWP: 146)*11		
<b>Refrigerant charge</b>	kg	1.4	1.4	
<b>Control method</b>		PID control		
<b>Ambient temperature</b> *1, 8		°C 2 to 45		
<b>Circulating fluid</b> *2		Tap water, 15 % Ethylene glycol aqueous solution, Deionised water		
<b>Set temperature range</b> *1		°C 5 to 35		
<b>Cooling capacity</b> *3, 8		15.7	20.6	
<b>Heating capacity</b> *4		3.5	4.0	
<b>Temperature stability</b> *5		°C ±0.1		
<b>Circulating fluid system</b>	<b>Pump capacity</b>	<b>Rated flow (Outlet)</b>	l/min 45 (0.45 MPa)	
		<b>Maximum flow rate</b>	l/min 130	
		<b>Maximum pump head</b>	m 50	
	<b>Settable pressure range</b> *6	MPa 0.1 to 0.5		
	<b>Minimum operating flow rate</b> *7	l/min 25	35	
	<b>Tank capacity</b>	L 42		
	<b>Circulating fluid outlet, circulating fluid return port</b>		Rc1 (Symbol F: G1, Symbol N: NPT1)	
	<b>Tank drain port</b>		Rc3/4 (Symbol F: G3/4, Symbol N: NPT3/4)	
	<b>Automatic fluid fill system (Standard)</b>	<b>Supply side pressure range</b>	MPa 0.2 to 0.5	
		<b>Supply side fluid temperature</b>	°C 5 to 35	
<b>Automatic fluid fill port</b>		Rc1/2 (Symbol F: G1/2, Symbol N: NPT1/2)		
<b>Overflow port</b>		Rc1 (Symbol F: G1, Symbol N: NPT1)		
<b>Fluid contact material</b>		<b>Metal</b> Stainless steel, Copper (Heat exchanger brazing), Brass, Bronze		
		<b>Resin</b> PTFE, PU, FKM, EPDM, PVC, NBR, POM, PE, NR		
<b>Facility water system</b>	<b>Temperature range</b>		°C 5 to 40	
	<b>Pressure range</b>		MPa 0.3 to 0.5	
	<b>Required flow</b> *10	l/min 30	50	
	<b>Facility water pressure differential</b>		MPa 0.3 or more	
	<b>Facility water inlet/outlet</b>		Rc1 (Symbol F: G1, Symbol N: NPT1)	
<b>Fluid contact material</b>		<b>Metal</b> Stainless steel, Copper (Heat exchanger brazing), Bronze, Brass		
		<b>Resin</b> PTFE, NBR, EPDM		
<b>Electrical system</b>	<b>Power supply</b>			
	3-phase 380 to 415 VAC (50 Hz) Allowable voltage range ±10 % (No continuous voltage fluctuation)			
	3-phase 380 to 480 VAC (60 Hz) Allowable voltage range +4 %, -10 % (Max. voltage less than 500 V and no continuous voltage fluctuation)			
	<b>Applicable earth leakage breaker (Standard)</b>	<b>Rated current</b>	A 30	
		<b>Sensitivity of leak current</b>	mA 30	
<b>Rated operating current</b> *5		A 12.7	15.6	
<b>Rated power consumption</b> *5		kW (kVA) 7.6 (8.8)	9.7 (10.8)	
<b>Noise level (Front 1 m/Height 1 m)*5</b>		dB (A) 60		
<b>Waterproof specification</b>		IPX4		
<b>Accessories</b>		Alarm code list stickers 2 pcs. (English 1 pc./Japanese 1 pc.), Operation Manual (for installation/operation) 2 pcs. (English 1 pc./Japanese 1 pc.), Y-strainer (40 meshes) 25A, Barrel nipple 25A, Anchor bolt fixing brackets 2 pcs. (including 6 M8 bolts)*9		
<b>Weight (dry state)</b>		kg Approx. 195		

\*1 Use a 15 % ethylene glycol aqueous solution if operating in a place where the ambient temperature and/or circulating fluid temperature is 10 °C or less. Also, when there is a possibility of the facility water being frozen, make sure to discharge all the facility water from the facility water circuit.

\*2 Use fluid in condition below as the circulating fluid. Also, when there is a possibility of the facility water being frozen, make sure to discharge all the facility water from the facility water circuit.  
Tap water: Standard of The Japan Refrigeration And Air Conditioning Industry Association (JRA GL-02-1994)  
15 % ethylene glycol aqueous solution: diluted by tap water in condition above without any additives such as antiseptics.  
Deionised water: Electric conductivity 1 μS/cm or higher (Electric resistivity 1 MΩ·cm or lower)

\*3 ① Facility water temperature: 32 °C, ② Circulating fluid: Tap water, ③ Circulating fluid temperature: 20 °C, ④ Circulating fluid flow rate: Rated flow, ⑤ Power supply: 400 VAC

\*4 ① Facility water temperature: 32 °C, ② Circulating fluid: Tap water, ③ Circulating fluid flow rate: Rated flow, ④ Power supply: 400 VAC

\*5 ① Facility water temperature: 32 °C, ② Circulating fluid: Tap water, ③ Circulating fluid temperature: 20 °C, ④ Load: Same as the cooling capacity, ⑤ Circulating fluid flow rate: Rated flow, ⑥ Power supply: 400 VAC, ⑦ Piping length: Shortest

\*6 With the pressure control mode by inverter. When the pressure control mode is not used, the pump power frequency set mode can be used.

\*7 Fluid flow rate to maintain the cooling capacity. If the actual flow rate is lower than this, install a bypass piping.

\*8 If the product is used at an altitude of 1000 meters or higher, the maximum allowable ambient temperature and the cooling capacity decrease. For details, refer to the operation manual.

\*9 The anchor bolt fixing brackets (including 6 M8 bolts) are used for fixing to wooden skids when packaging the thermo-chiller. No anchor bolt is included.

\*10 The actual flow rate of facility water will fluctuate according to your operating conditions.

\*11 R454C is a slightly flammable refrigerant. Avoid using this product in proximity to open flames.

**Cooling Capacity**

\* If the product is used at an altitude of 1000 meters or higher, the maximum allowable ambient temperature and the cooling capacity decrease. For details, refer to the operation manual.

**HRSF150-A□-40-□**

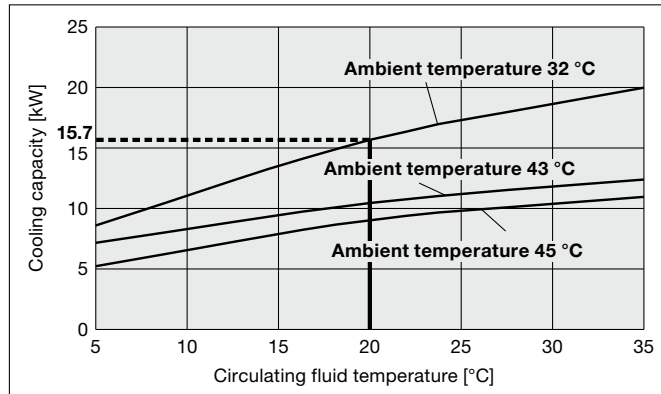

**HRSF150-W□-40-□**

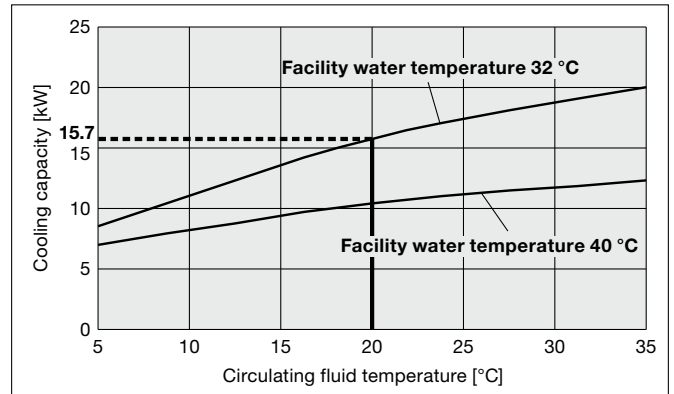

**HRSF200-A□-40-□**

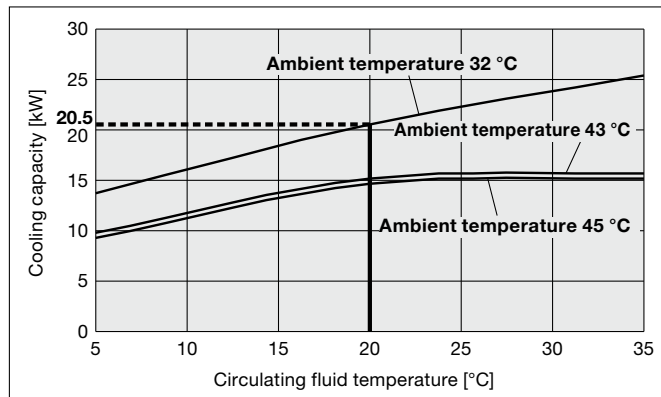

**HRSF200-W□-40-□**

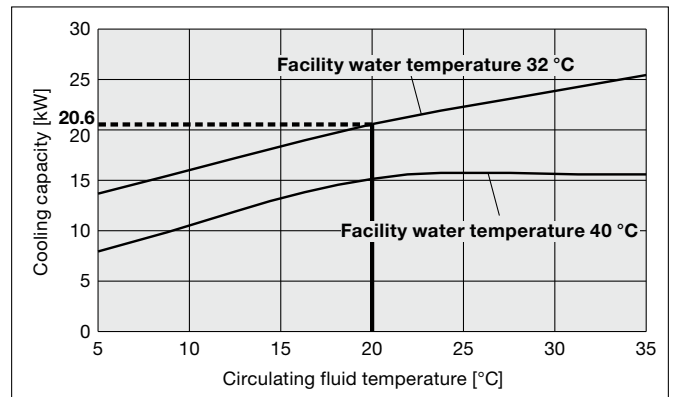

**Pump Capacity**

**HRSF150/200-A□-40-□**

**HRSF150/200-W□-40-□**

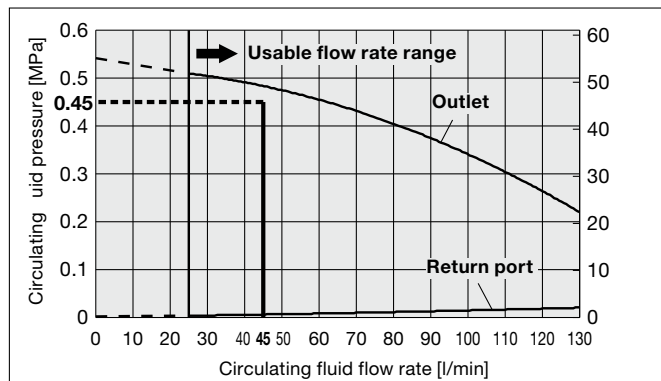

# HRSF150/200 Series Standard Type

## Dimensions

### HRSF150/200-A-40 (Air-cooled 400 V type)

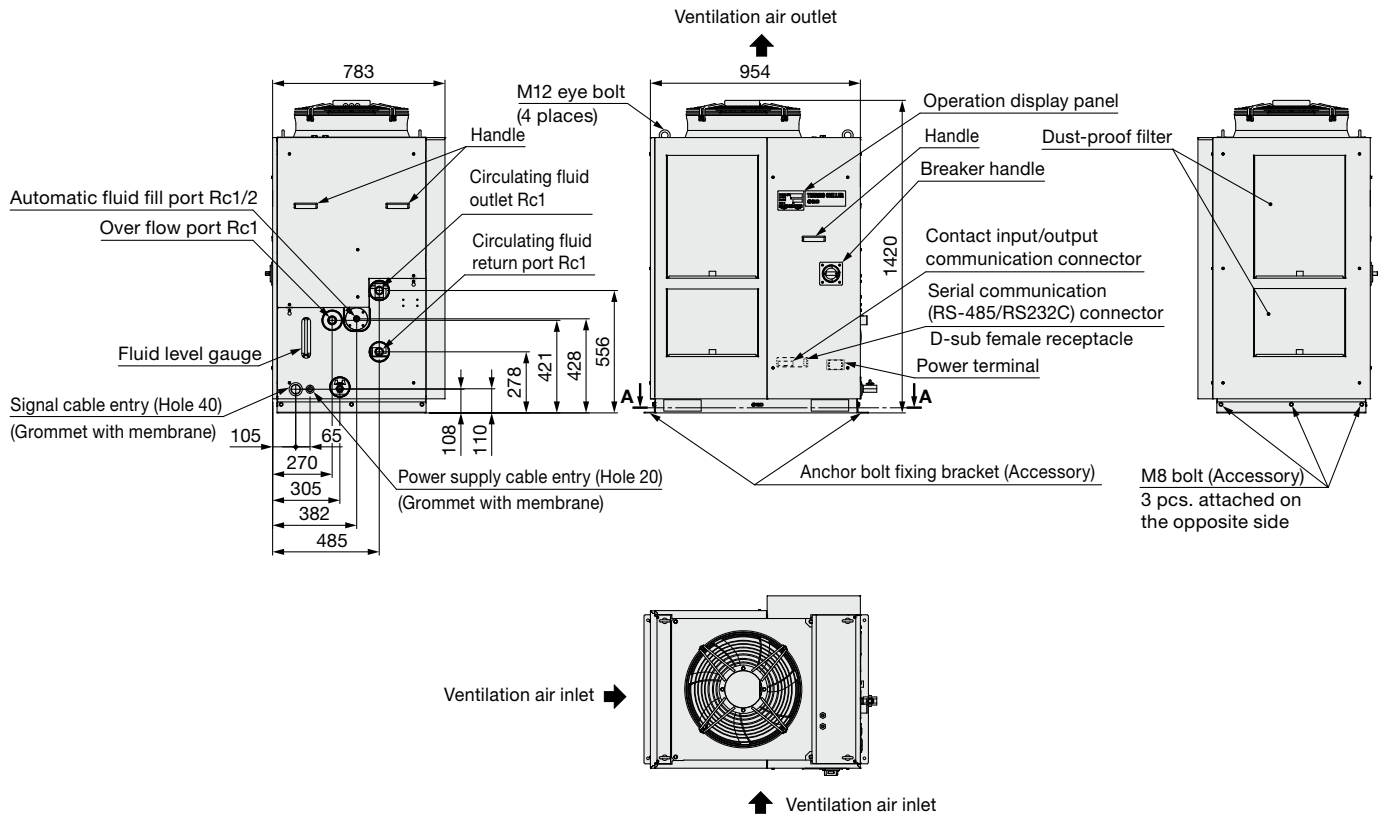

### Anchor bolt fixing position

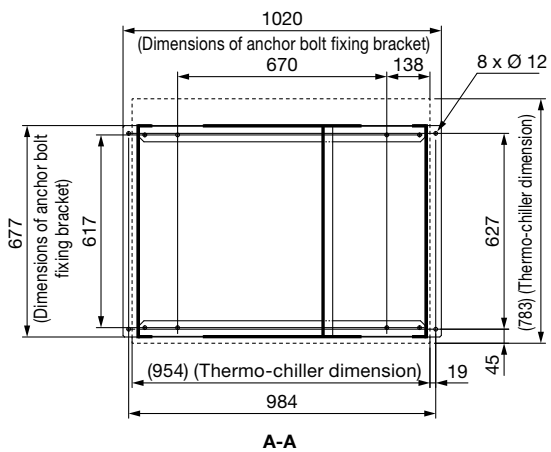

**Dimensions**

**HRSF150/200-W-40 (Water-cooled 400 V type)**

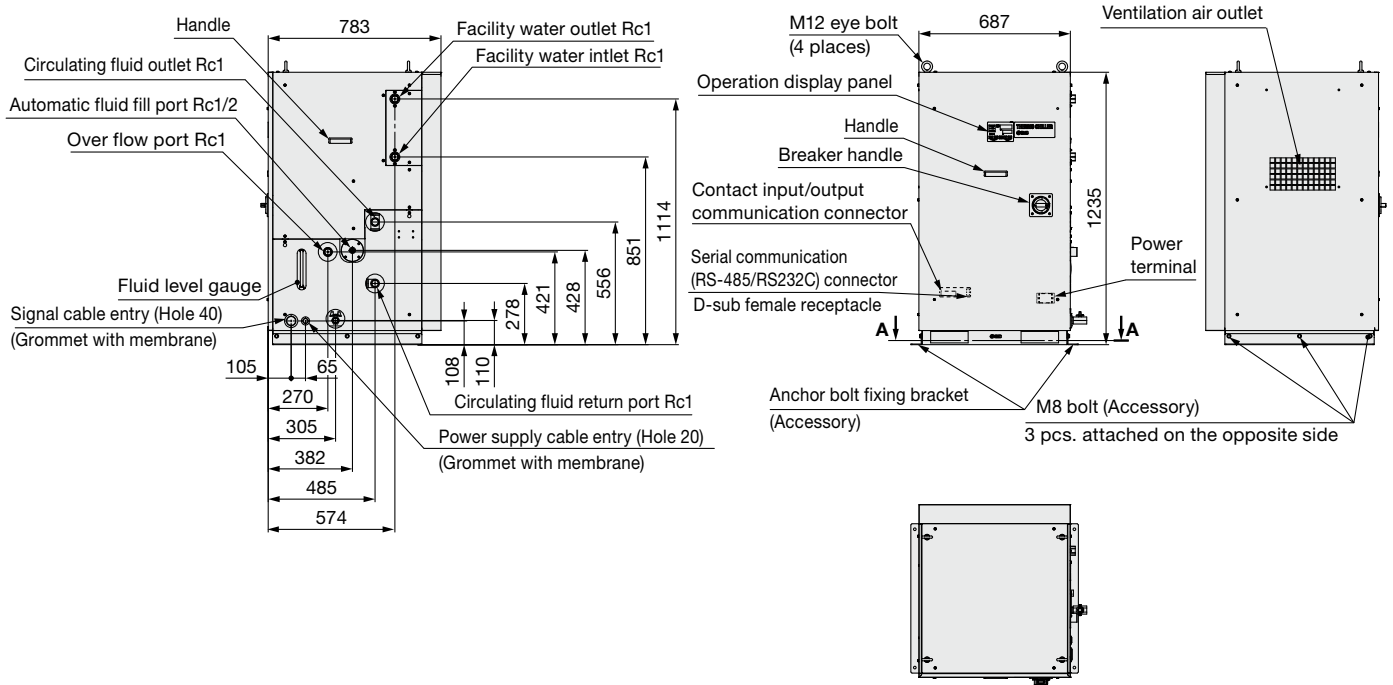

**Anchor bolt fixing position**

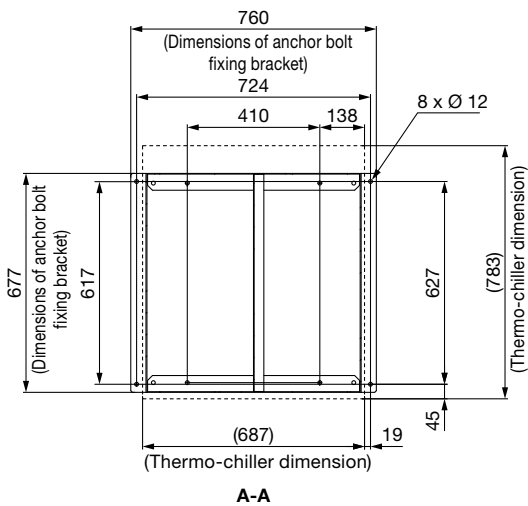

**Accessory: Y-strainer mounting view**

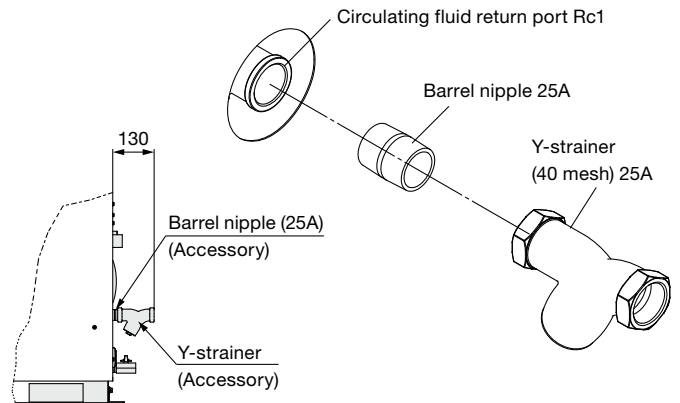

# HRSF150/200 Series Options

\* Options have to be selected when ordering the thermo-chiller. It is not possible to add them after purchasing the unit.

**A** Option symbol

## With Caster Adjuster-foot

HRSF150/200-□-□-□-□-**A**

● With caster adjuster-foot

Unfixed casters and adjuster feet stops are mounted.

Applicable model	Dimension [mm]		Additional weight*1 [kg]
	A	B	
HRSF150/200-A-□-□-□- <b>A</b>	830	1538	Approx. 18
HRSF150/200-W-□-□-□- <b>A</b>	570	1353	

\*1 Refers to the amount of increase from the standard weight

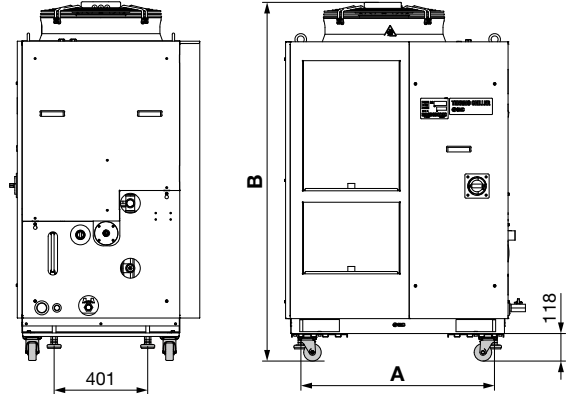

**K** Option symbol

## With Fluid Fill Port

HRSF□-□-□-□-**K**

● With fluid fill port

When the automatic fluid fill in port is not used, water can be supplied manually without removing the panel.

Applicable model	Dimension [mm]	
	A	B
HRSF150-□-□-□- <b>K</b>	271	609
HRSF200-□-□-□- <b>K</b>		

Option

[K: With fluid fill port]  
Thread size: G1 1/2  
(With cap)

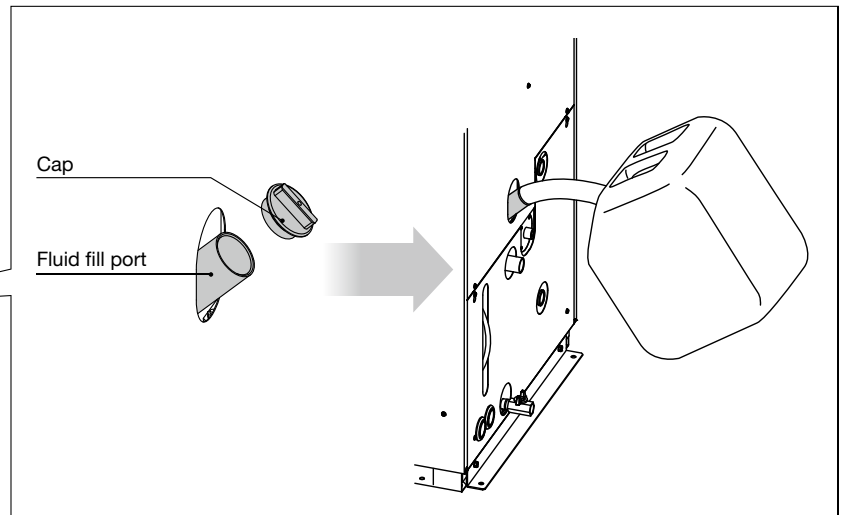
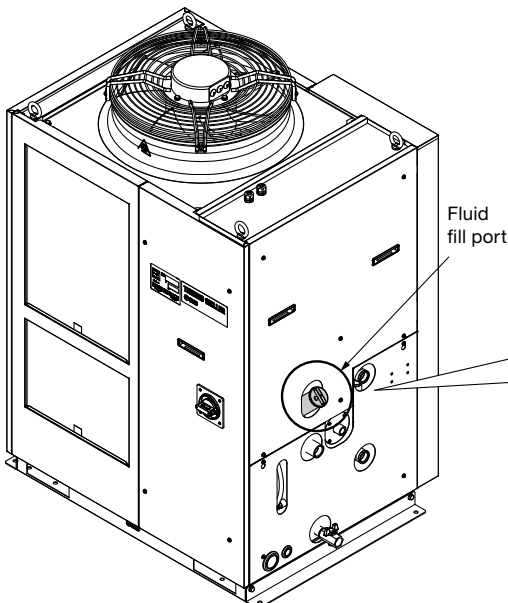
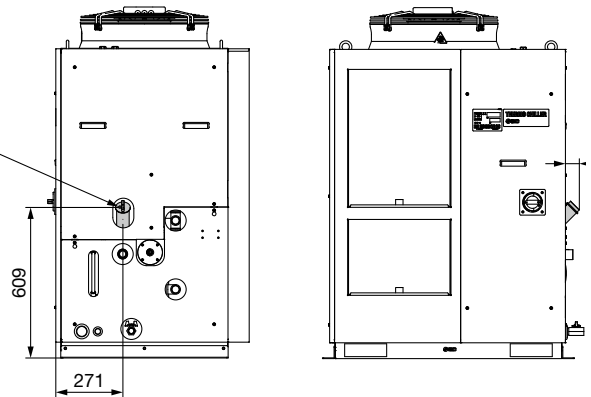

(The figure shows the HRSF200-A-20-K.)



**M** Option symbol

**Applicable to DI Water Piping**

**HRSF □-□□-□-**M****

● **Applicable to DI water piping**

Contact material of the circulating fluid circuit is made from non-copper materials.

Applicable model	<b>HRSF□-□□-□-<b>M</b></b>
Contact material for circulating fluid	Stainless steel (including heat exchanger brazing), PTFE, PU, FKM, EPDM, PVC, NBR, POM

\* No change in external dimensions

# HRSF150/200 Series Optional Accessories

## ① Piping Conversion Fitting

This is a fitting to change the port from Rc to G or NPT.

- Circulating fluid outlet, Circulating fluid return port, Overflow port Rc1 → NPT1 or G1
- Drain port Rc3/4 → NPT3/4 or G3/4
- Automatic fluid fill port Rc1/2 → NPT1/2 or G1/2
- Facility water inlet, Facility water outlet Rc1 → NPT1 or G1 (for HRS-EP015 or HRS-EP016)

(It is not necessary to purchase this when pipe thread type F or N is selected in “How to Order” since it is included in the product.)

Part no.	Contents	Applicable model
HRS-EP013	NPT thread conversion fitting set	HRSF150/200□-A-□
HRS-EP014	G thread conversion fitting set	
HRS-EP015	NPT thread conversion fitting set	HRSF150/200□-W-□
HRS-EP016	G thread conversion fitting set	

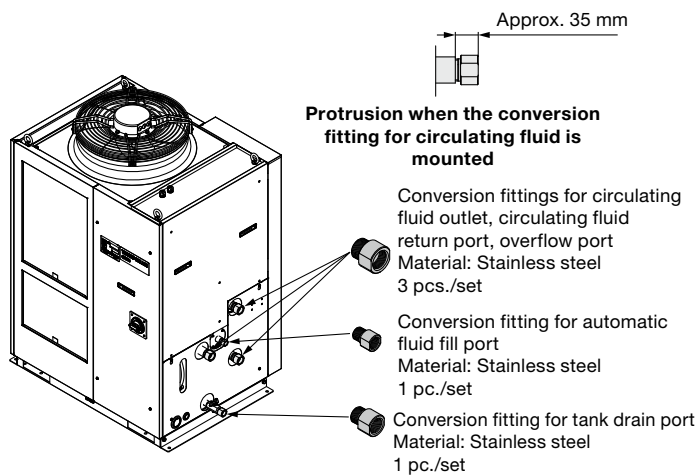

HRS-EP013, HRS-EP014

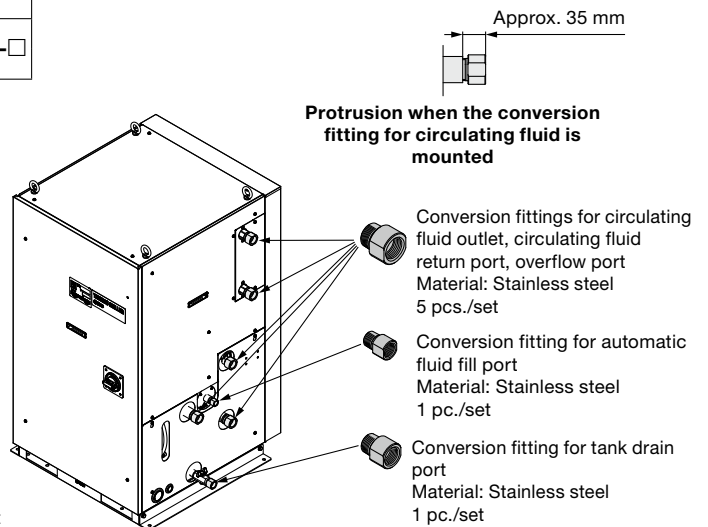

HRS-EP015, HRS-EP016

## ② Caster Adjuster-foot Kit

This is a set of unfixed casters and adjuster feet stop.

When installed by the customer, it is necessary to lift the thermo-chiller by a forklift or sling work. Carefully read the procedure manual included with this kit before performing the installation.

Part no.	Applicable model	Dimension [mm]	Weight [kg]
		A	
HRS-KS002	HRSF150-A-□-□	830	Approx. 18
	HRSF200-A-□-□		
	HRSF150-W-□-□	570	
	HRSF200-W-□-□		

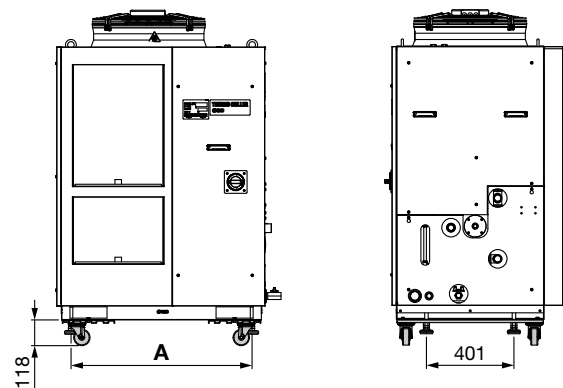
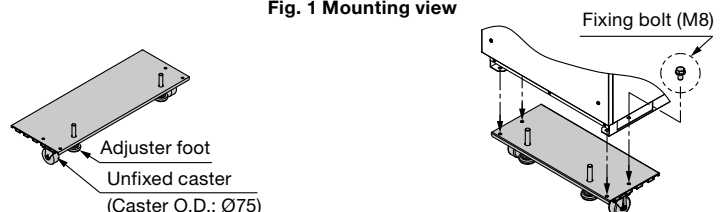

Fig. 1 Mounting view

### Parts List

Description
Procedure manual
Caster adjuster-foot bracket (2 pcs.)
Fixing bolt (M8) (8 pcs.)



## ③ Electric Conductivity Control Set

The set indicates and controls the electric conductivity of the circulating fluid. Refer to the Operation Manual for details.

Part no.	Applicable model
<b>HRS-DI006</b>	<b>HRSF150-□□-□</b>
	<b>HRSF200-□□-□</b>

Measurement range of electric conductivity	2.0 to 48.0 $\mu\text{S}/\text{cm}$
Set range of electric conductivity target	5.0 to 45.0 $\mu\text{S}/\text{cm}$
Set range of electric conductivity hysteresis	2.0 to 10.0 $\mu\text{S}/\text{cm}$
Operating temperature range (Circulating fluid temperature)	5 to 60 °C
Power consumption	400 mA or less
Installation environment	Indoor

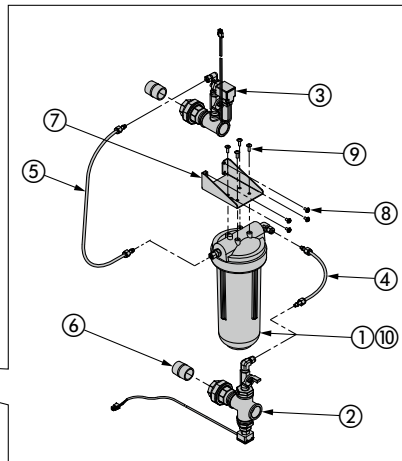
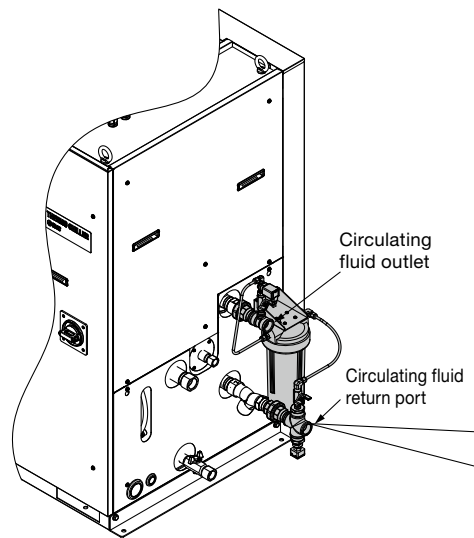
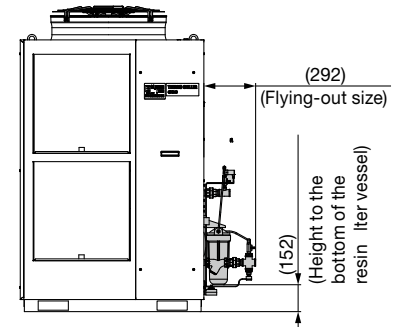

### Parts List

No.	Description	Fluid contact material	Qty.
①	DI filter vessel	PC, PP	1
②	DI sensor assembly	Stainless steel, PPS	1
③	DI control piping assembly	Stainless steel, EPDM	1
④	DI filter outlet tube	PFA, POM	1
⑤	DI filter inlet tube	PFA, POM	1
⑥	Nipple (Size: 1 inch)	Stainless steel	2
⑦	Mounting bracket	—	1
⑧	Mounting screw (M5 screw)	—	4
⑨	Tapping screw (M5 screw)	—	4
⑩	DI filter cartridge (Part no.: HRS-DF001)*1	PP, PE	1

\*1 The product should be replaced when it can no longer preserve the electrical conductivity set value.

## ④ Bypass Piping Set

When the circulating fluid goes below the minimum operating flow rate (as shown below), cooling capacity will be reduced and the temperature stability will be badly affected. Use the bypass piping set to ensure a circulating fluid flow rate of the minimum operating flow rate or more.

Part no.	Applicable model	Minimum operating flow rate [l/min]
<b>HRS-BP005</b>	<b>HRSF150-□□-□</b> <b>HRSF200-□□-□</b>	25

### ■ Bypass Piping Set (Stainless steel)

Part no.	Applicable model	Minimum operating flow rate [l/min]
<b>HRS-BP011</b>	<b>HRSF150-□□-□</b> <b>HRSF200-□□-□</b>	25

\*1 When option "M" is selected, we recommend using the HRS-BP011.

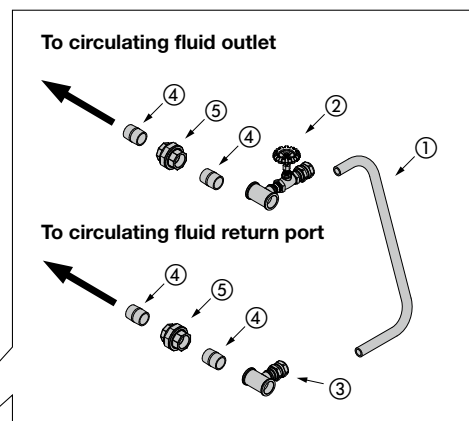

### Parts List

No.	Description	Fluid contact material		Qty.
		HRS-BP005	HRS-BP011	
①	Hose (I.D.: 15 mm)	PVC	PVC	1 (Approx. 700 mm)
②	Outlet piping assembly (With globe valve)	Stainless steel, Brass, Bronze	SUS	1
③	Return piping assembly	Stainless steel, Brass	SUS	1
④	Nipple (Size: 1 inch)	Stainless steel	SUS	4
⑤	Union (Size: 1 inch)	Stainless steel	SUS	2
⑥	Sealant tape	PTFE	PTFE	1
⑦	Operation Manual	—	—	1

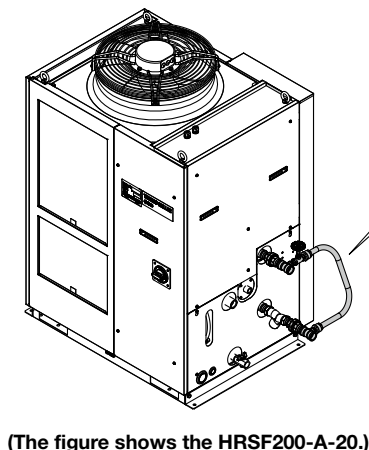

(The figure shows the HRSF200-A-20.)

# HRSF150/200 Series

## ⑤ Snow Protection Hood

Stainless steel snow protection hood for air-cooled chiller.

According to the mounting direction of the snow protection hood, the ventilation from the fan can be selected from four directions, front, rear, left and right.

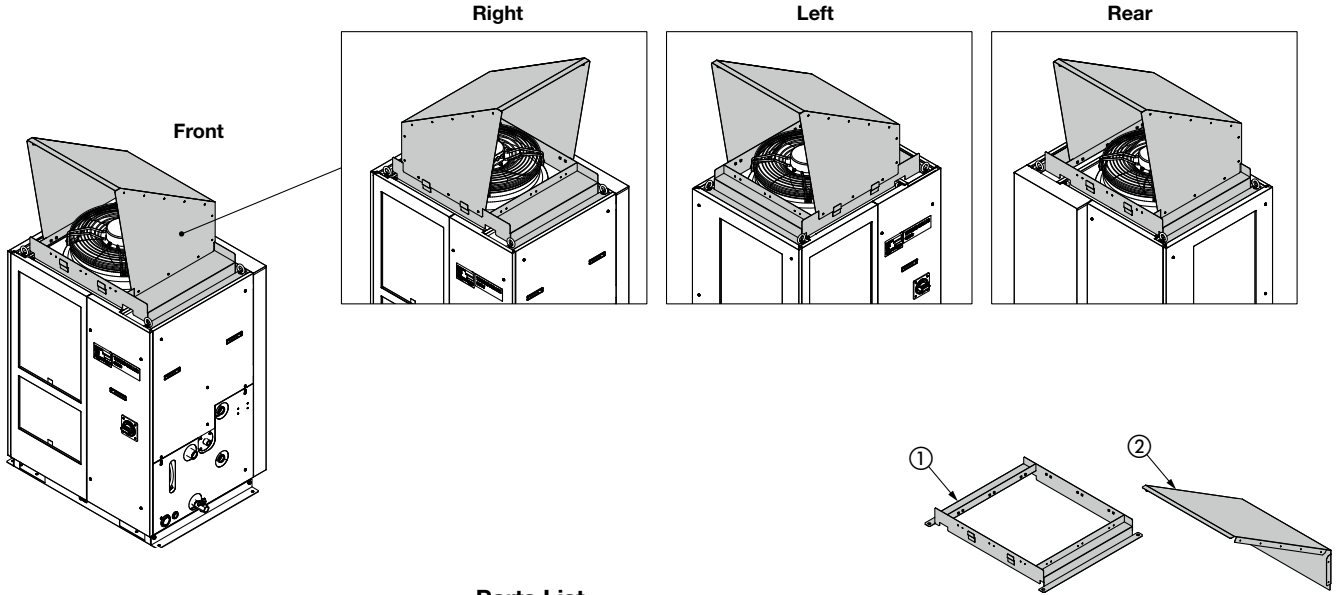

Part no.	Applicable model	Weight [kg]
<b>HRS-BK004</b>	<b>HRSF150-A□-□</b> <b>HRSF200-A□-□</b>	18

### Parts List

No.	Description	Qty.
①	Snow protection hood base	1
②	Snow protection hood A	1
③	Snow protection hood B	2
④	Assembly/Mounting screw	20

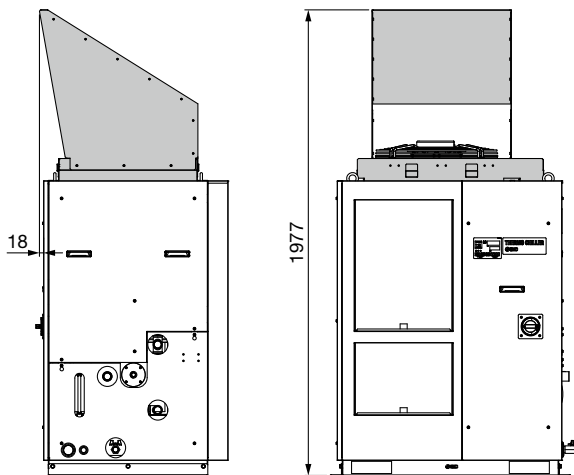

Mounting condition for HRS-BK004

\* This hood does not completely prevent snow from entering the inside of the chiller.

## ⑥ Particle Filter Set

Removes foreign matter in the circulating fluid. This set cannot be directly connected to the thermo-chiller. Install it in the user's piping system. Refer to the Operation Manual for details.

### Particle Filter Set

**HRS-PF005-H**

#### ● Accessory

Symbol	Accessory
—	None
H	With handle

Fluid	Tap water
Max. operating pressure	0.65 MPa
Operating temperature range	5 to 35 °C
Nominal filtration accuracy	5 μm
Installation environment	Indoors

#### Parts List

No.	Description	Material	Qty.	Note
①	Body	PC, PP	1	—
②	Element*1	PP	1	—
③	Extension piece	Stainless steel	2	Conversion from NPT to Rc
④	Handle	—	1	When -H is selected
⑤	Sealant tape	PTFE	1	—

### Replacement Element

**HRS-PF006**

The product should be replaced when the pressure drop reaches 0.1 MPa.

\*1 The product should be replaced when the pressure drop reaches 0.1 MPa.

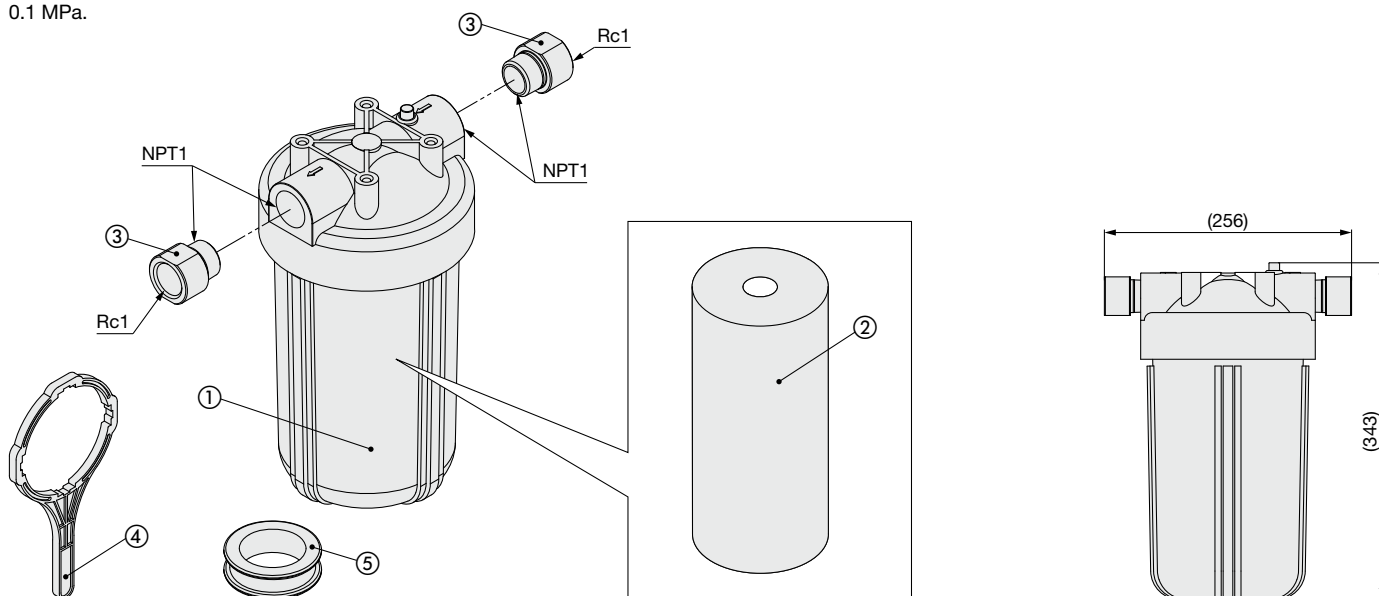

# HRSF150/200 Series

## ⑦ Wired Remote Controller

When the wired remote controller is connected to the thermo-chiller, the operation start/stop setting or the set temperature can be changed from a place apart from the thermo-chiller. For details, refer to the Operation Manual.

### Wired Remote Controller

HRS-CV004-1

#### Accessories

Symbol	Accessories
—	None
1	With cable (Approx. 20 m)
2	With cable (Approx. 50 m)
3	With cable (Approx. 100 m)

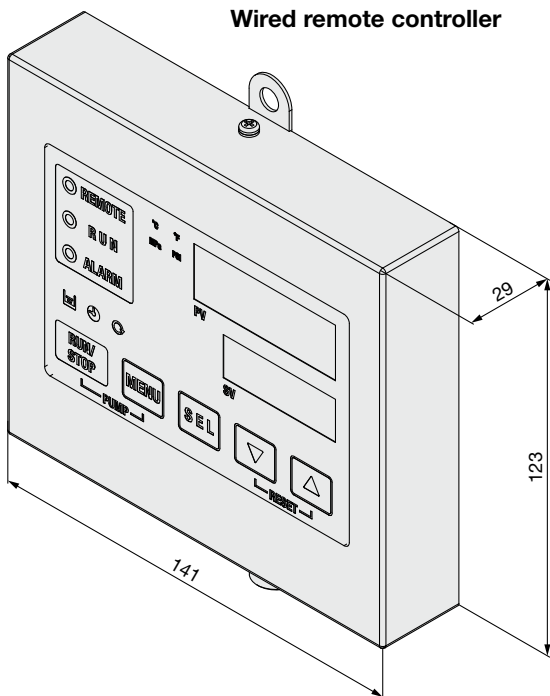

#### Displayed items

Circulating fluid discharge temperature
Circulating fluid discharge set temperature
Circulating fluid discharge pressure
Circulating fluid electric conductivity*1
Circulating fluid flow rate
Alarm code*2

\*1 Only when the electric conductivity control set is used.

\*2 Only when an alarm occurs. The alarm cannot be reset with the remote controller. Be sure to reset the alarm with the thermo-chiller main unit.

#### Operable items

Operation start/stop
Circulating fluid temperature setting
Alarm sound stop
Key-lock
Key operation sound ON/OFF
Digital display brightness adjustment
Alarm sound ON/OFF

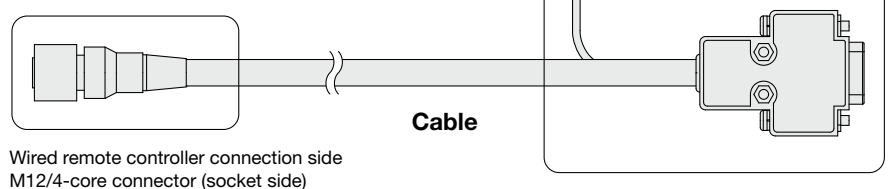

- \* To use the wired remote controller, the thermo-chiller main unit setting is needed.
- \* Use the wired remote controller indoors.
- \* Pass the cable through the duct, etc. so that it is not exposed to rain water or direct sunlight.

# HRSF150/200 Series

# Cooling Capacity Calculation

## Required Cooling Capacity Calculation

### Example 1: When the heat generation amount in the user's equipment is known.

The heat generation amount can be determined based on the power consumption or output of the heat generating area — i.e. the area requiring cooling — within the user's equipment.\*1

① Derive the heat generation amount from the power consumption.

Power consumption **P**: 20 [kW]

$$Q = P = 20 \text{ [kW]}$$

$$\text{Cooling capacity} = \text{Considering a safety factor of 20 \%}, 20 \text{ [kW]} \times 1.2 = \boxed{24 \text{ [kW]}}$$

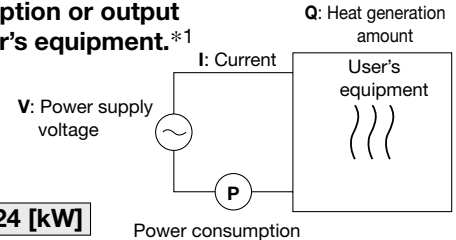

② Derive the heat generation amount from the power supply output.

Power supply output **VI**: 20 [kVA]

$$Q = P = V \times I \times \text{Power factor}$$

In this example, using a power factor of 0.85:

$$= 20 \text{ [kVA]} \times 0.85 = 17 \text{ [kW]}$$

Cooling capacity = Considering a safety factor of 20 %,

$$17 \text{ [kW]} \times 1.2 = \boxed{20.4 \text{ [kW]}}$$

③ Derive the heat generation amount from the output.

Output (shaft power, etc.) **W**: 13 [kW]

$$Q = P = \frac{W}{\text{Efficiency}}$$

In this example, using an efficiency of 0.7:

$$= \frac{13}{0.7} = 18.6 \text{ [kW]}$$

Cooling capacity = Considering a safety factor of 20 %,

$$18.6 \text{ [kW]} \times 1.2 = \boxed{22.3 \text{ [kW]}}$$

\*1 The examples above calculate the heat generation amount based on the power consumption. The actual heat generation amount may differ due to the structure of the user's equipment. Be sure to check it carefully.

### Example 2: When the heat generation amount in the user's equipment is not known.

Obtain the temperature difference between inlet and outlet by circulating the circulating fluid inside the user's equipment.

- Heat generation amount by user's equipment **Q** : Unknown [W] (J/s)
- Circulating fluid : Tap water\*1
- Circulating fluid mass flow rate **qm** : (=  $\rho \times qv \div 60$ ) [kg/s]
- Circulating fluid density  $\rho$  : 1 [kg/L]
- Circulating fluid (volume) flow rate **qv** : 70 [l/min]
- Circulating fluid specific heat **C** :  $4.186 \times 10^3$  [J/(kg·K)]
- Circulating fluid outlet temperature **T1** : 293 [K] (20 [°C])
- Circulating fluid return temperature **T2** : 297 [K] (24 [°C])
- Circulating fluid temperature difference  $\Delta T$  : 4 [K] (=  $T_2 - T_1$ )
- Conversion factor: minutes to seconds (SI units): 60 [s/min]

$$Q = qm \times C \times (T_2 - T_1)$$

$$= \frac{\rho \times qv \times C \times \Delta T}{60} = \frac{1 \times 70 \times 4.186 \times 10^3 \times 4.0}{60}$$

$$= 19535 \text{ [J/s]} \approx 19535 \text{ [W]} = 19.5 \text{ [kW]}$$

Cooling capacity = Considering a safety factor of 20 %,

$$19.5 \text{ [kW]} \times 1.2 = \boxed{23.4 \text{ [kW]}}$$

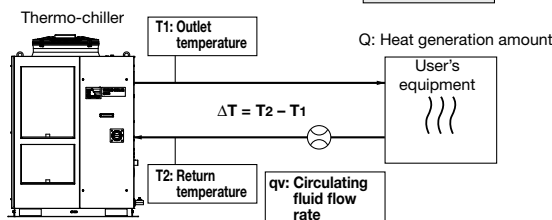

### Example of conventional units (Reference)

- Heat generation amount by user's equipment **Q**: Unknown [cal/h] → [W]
- Circulating fluid : Tap water\*1
- Circulating fluid weight flow rate **qm**: (=  $\rho \times qv \times 60$ ) [kgf/h]
- Circulating fluid weight volume ratio  $\gamma$ : 1 [kgf/L]
- Circulating fluid (volume) flow rate **qv** : 70 [l/min]
- Circulating fluid specific heat **C** :  $1.0 \times 10^3$  [cal/(kgf·°C)]
- Circulating fluid outlet temperature **T1**: 20 [°C]
- Circulating fluid return temperature **T2**: 24 [°C]
- Circulating fluid temperature difference  $\Delta T$ : 4 [°C] (=  $T_2 - T_1$ )
- Conversion factor: hours to minutes : 60 [min/h]
- Conversion factor: kcal/h to kW : 860 [(cal/h)/W]

$$Q = \frac{qm \times C \times (T_2 - T_1)}{860}$$

$$= \frac{\gamma \times qv \times 60 \times C \times \Delta T}{860}$$

$$= \frac{1 \times 70 \times 60 \times 1.0 \times 10^3 \times 4.0}{860}$$

$$= \frac{16800000 \text{ [cal/h]}}{860}$$

$$\approx 19534 \text{ [W]} = 19.5 \text{ [kW]}$$

Cooling capacity = Considering a safety factor of 20 %,

$$19.5 \text{ [kW]} \times 1.2 = \boxed{23.4 \text{ [kW]}}$$

## Required Cooling Capacity Calculation

**Example 3: When there is no heat generation, and when cooling the object below a certain temperature and period of time.**

Heat quantity by cooled substance (per unit time) **Q** : Unknown [W] [(J/s)]  
 Cooled substance : Water  
 Cooled substance mass **m** : (=  $\rho \times V$ ) [kg]  
 Cooled substance density  $\rho$  : 1 [kg/L]  
 Cooled substance total volume **V** : 300 [L]  
 Cooled substance specific heat **C** :  $4.186 \times 10^3$  [J/(kg·K)]  
 Cooled substance temperature when cooling begins **T<sub>0</sub>** : 305 [K] (32 [°C])  
 Cooled substance temperature after t hour **T<sub>t</sub>** : 293 [K] (20 [°C])  
 Cooling temperature difference  $\Delta T$  : 12 [K] (=  $T_0 - T_t$ )  
 Cooling time  $\Delta t$  : 900 [s] (= 15 [min])

\* Refer to the following for the typical physical property values by circulating fluid.

$$Q = \frac{m \times C \times (T_0 - T_t)}{\Delta t} = \frac{\rho \times V \times C \times \Delta T}{\Delta t}$$

$$= \frac{1 \times 300 \times 4.186 \times 10^3 \times 12}{900} = 16744 \text{ [J/s]} \approx 16.7 \text{ [kW]}$$

Cooling capacity = Considering a safety factor of 20 %,

$$16.7 \text{ [kW]} \times 1.2 = \boxed{20 \text{ [kW]}}$$

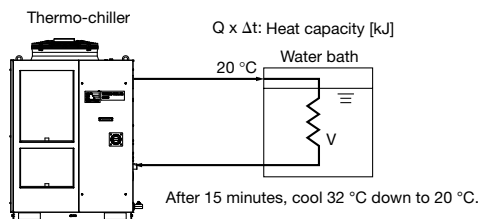

### Example of conventional units (Reference)

Heat quantity by cooled substance (per unit time) **Q** : Unknown [cal/h] → [W]  
 Cooled substance : Water  
 Cooled substance weight **m** : (=  $\rho \times V$ ) [kgf]  
 Cooled substance weight volume ratio  $\gamma$  : 1 [kgf/L]  
 Cooled substance total volume **V** : 300 [L]  
 Cooled substance specific heat **C** :  $1.0 \times 10^3$  [cal/(kgf·°C)]  
 Cooled substance temperature when cooling begins **T<sub>0</sub>** : 32 [°C]  
 Cooled substance temperature after t hour **T<sub>t</sub>** : 20 [°C]  
 Cooling temperature difference  $\Delta T$  : 12 [°C] (=  $T_0 - T_t$ )  
 Cooling time  $\Delta t$  : 15 [min]  
 Conversion factor: hours to minutes : 60 [min/h]  
 Conversion factor: kcal/h to kW : 860 [(cal/h)/W]

$$Q = \frac{m \times C \times (T_0 - T_t)}{\Delta t \times 860} = \frac{\gamma \times V \times 60 \times C \times \Delta T}{\Delta t \times 860}$$

$$= \frac{1 \times 300 \times 60 \times 1.0 \times 10^3 \times 12}{15 \times 860}$$

$$\approx 16744 \text{ [W]} = 16.7 \text{ [kW]}$$

Cooling capacity = Considering a safety factor of 20 %,

$$16.7 \text{ [kW]} \times 1.2 = \boxed{20 \text{ [kW]}}$$

\* This is the calculated value by changing the fluid temperature only. Thus, it varies substantially depending on the water bath or piping shape.

## Precautions on Cooling Capacity Calculation

### 1. Heating capacity

When the circulating fluid temperature is set above room temperature, it needs to be heated by the thermo-chiller. The heating capacity depends on the circulating fluid temperature. Consider the radiation rate and heat capacity of the user's equipment and check beforehand if the required heating capacity is provided.

### 2. Pump capacity

#### <Circulating fluid flow rate>

Circulating fluid flow rate varies depending on the circulating fluid discharge pressure. Consider the installation height difference between the thermo-chiller and the user's equipment, and the piping resistance such as circulating fluid pipings, or piping size, or piping curves in the machine. Check beforehand if the required flow is achieved, using the pump capacity curves.

#### <Circulating fluid discharge pressure>

Circulating fluid discharge pressure has the possibility to increase up to the maximum pressure in the pump capacity curves.

Check beforehand if the circulating fluid pipings or circulating fluid circuit of the user's equipment are fully durable against this pressure.

## Circulating Fluid Typical Physical Property Values

### 1. This catalogue uses the following values for density and specific heat in calculating the required cooling capacity.

Density  $\rho$ : 1 [kg/L] (or, using conventional units, weight volume ratio  $\gamma = 1$  [kgf/L])

Specific heat **C**:  $4.19 \times 10^3$  [J/(kg·K)] (or, using conventional units,  $1 \times 10^3$  [cal/(kgf·°C)])

### 2. Values for density and specific heat change slightly according to temperature shown below. Use this as a reference.

#### Water

Physical property value Temperature	Density $\rho$ [kg/L]	Specific heat C [J/(kg·K)]	Conventional units	
			Weight volume ratio $\gamma$ [kgf/L]	Specific heat C [cal/(kgf·°C)]
5 °C	1.00	$4.2 \times 10^3$	1.00	$1 \times 10^3$
10 °C	1.00	$4.19 \times 10^3$	1.00	$1 \times 10^3$
15 °C	1.00	$4.19 \times 10^3$	1.00	$1 \times 10^3$
20 °C	1.00	$4.18 \times 10^3$	1.00	$1 \times 10^3$
25 °C	1.00	$4.18 \times 10^3$	1.00	$1 \times 10^3$
30 °C	1.00	$4.18 \times 10^3$	1.00	$1 \times 10^3$
35 °C	0.99	$4.18 \times 10^3$	0.99	$1 \times 10^3$
40 °C	0.99	$4.18 \times 10^3$	0.99	$1 \times 10^3$

#### 15 % Ethylene Glycol Aqueous Solution

Physical property value Temperature	Density $\rho$ [kg/L]	Specific heat C [J/(kg·K)]	Conventional units	
			Weight volume ratio $\gamma$ [kgf/L]	Specific heat C [cal/(kgf·°C)]
5 °C	1.02	$3.91 \times 10^3$	1.02	$0.93 \times 10^3$
10 °C	1.02	$3.91 \times 10^3$	1.02	$0.93 \times 10^3$
15 °C	1.02	$3.91 \times 10^3$	1.02	$0.93 \times 10^3$
20 °C	1.01	$3.91 \times 10^3$	1.01	$0.93 \times 10^3$
25 °C	1.01	$3.91 \times 10^3$	1.01	$0.93 \times 10^3$
30 °C	1.01	$3.91 \times 10^3$	1.01	$0.94 \times 10^3$
35 °C	1.01	$3.91 \times 10^3$	1.01	$0.94 \times 10^3$
40 °C	1.01	$3.92 \times 10^3$	1.01	$0.94 \times 10^3$

\* Shown above are reference values.





# HRSF150/200 Series Specific Product Precautions 1

Be sure to read this before handling the products. Refer to the back cover for safety instructions. For temperature control equipment precautions, refer to the “Handling Precautions for SMC Products” and the “Operation Manual” on the SMC website: <https://www.smc.eu>

## Design

### Warning

#### 1. This catalogue shows the specifications of a single unit.

- 1) Check the specifications of the single unit (contents of this catalogue) and thoroughly consider the adaptability between the user’s system and this unit.
- 2) Although a protection circuit as a single unit is installed, prepare a drain pan, water leakage sensor, discharge air facility, and emergency stop equipment, depending on the user’s operating conditions. Also, the user is requested to carry out a safety design for the whole system.

#### 2. When attempting to cool areas that are open to the atmosphere (tanks, pipes), plan your piping system accordingly.

When cooling open-air external tanks, arrange the piping so that there are coil pipes for cooling inside the tanks and to carry back the entire flow volume of circulating fluid that is released.

#### 3. Use non-corrosive material for circulating fluid and facility water contact parts.

Using corrosive materials such as aluminium or iron for fluid contact parts such as piping may cause clogging or leakage in the circulating fluid and facility water circuits. Provide protection against corrosion when you use the product.

#### 4. The facility water outlet temperature (water-cooled type) may increase up to around 60 °C.

When selecting the facility water pipings, consider the suitability for temperature.

#### 5. This product uses a slightly flammable refrigerant (R454C). Avoid using this product in proximity to open flames.

Ensure compliance with local laws and regulations regarding the use and application of this product.



## Transportation / Carriage / Movement

### Warning

#### 1. This product will require an acceptance with the product not unloaded from the truck, and the user will need to unload the product by himself. Prepare a forklift.

The product will be delivered in the packaging shown below.

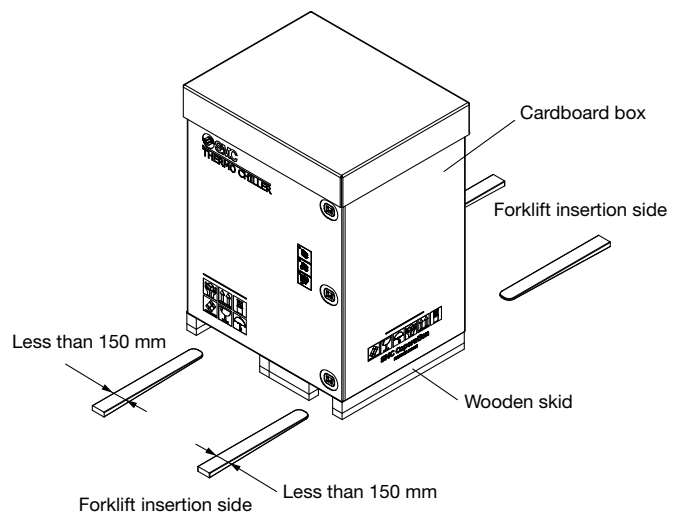

#### <When Packaged>

Model	Weight [kg]	Dimensions [mm]
HRSF150-A□-40	271	Height 1585 x Width 1185 x Depth 955
HRSF200-A□-40		
HRSF150-W□-40	230	Height 1485 x Width 925 x Depth 955
HRSF200-W□-40		
HRSF150-A□-40-A	289	Height 1710 x Width 1185 x Depth 955
HRSF200-A□-40-A		
HRSF150-W□-40-A	248	Height 1610 x Width 925 x Depth 955
HRSF200-W□-40-A		

#### 2. Transporting with forklift

- 1) A licensed driver should drive the forklift.
- 2) The proper place to insert the tines of the forklift differs depending on the model of cooler. Check the insert position, and be sure to drive the fork in far enough for it to come out the other side.
- 3) Be careful not to bump the fork to the cover panel or piping ports.



# HRSF150/200 Series Specific Product Precautions 2

Be sure to read this before handling the products. Refer to the back cover for safety instructions. For temperature control equipment precautions, refer to the “Handling Precautions for SMC Products” and the “Operation Manual” on the SMC website: <https://www.smc.eu>

## Transportation / Carriage / Movement

### Warning

#### 3. Hanging transportation

- 1) Crane manipulation and slinging work should be done by an eligible person.
- 2) Do not grip the piping on the right side or the handles of the panel.
- 3) When hanging by the eye bolts, be sure to use a 4-point hanging method. For the hanging angle, use caution regarding the position of the centre of gravity and hold it within 60°.

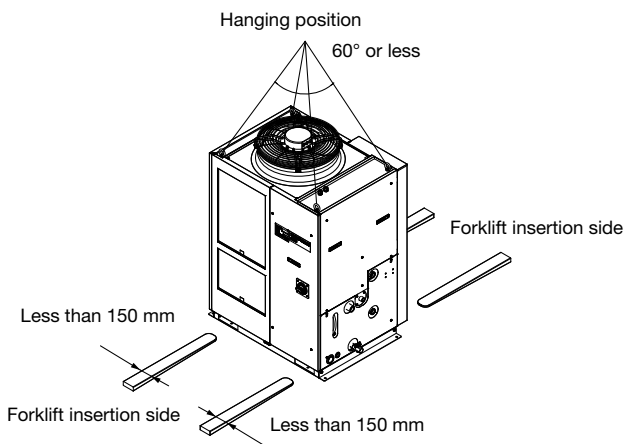

(When using option A/With caster adjuster-foot and optional accessories/Caster adjuster-foot kit HRS-KS002)

#### 4. Transporting with casters

- 1) This product is heavy and should be moved by at least two people.
- 2) Do not grip the piping port on the right side or the handles of the panel.
- 3) When transporting using a forklift, be sure not to let it hit the casters or adjusters, and drive the fork all the way through until it comes out the other side.
- 4) Do not get across steps with casters.

5. This product cannot be transported by air as this product uses a slightly flammable refrigerant (R454C).

### Caution

If this product is to be transported after delivery, please use the original packaging the product was delivered in. If other packaging is to be used, carefully package the product so as to prevent the product from incurring any damage during transport.

#### Refrigerant with GWP reference

Refrigerant	Global Warming Potential (GWP)		
	Regulation (EU) 2024/573, AIM Act 40 CFR Part 84	Fluorocarbon Emissions Control Act (Japan) GWP value labeled on products	GWP value to be used for reporting the calculated amount of leakage
R134a	1,430	1,430	1,300
R404A	3,922	3,920	3,940
R407C	1,774	1,770	1,620
R410A	2,088	2,090	1,920
R448A	1,386	1,390	1,270
R454C	146	145	146

\*1 This product is hermetically sealed and contains fluorinated greenhouse gases.

\*2 For refrigerant type used in this product, refer to the product specifications.

## Safety Instructions

These safety instructions are intended to prevent hazardous situations and/or equipment damage. These instructions indicate the level of potential hazard with the labels of “Caution,” “Warning” or “Danger.” They are all important notes for safety and must be followed in addition to International Standards (ISO/IEC) <sup>1)</sup>, and other safety regulations.

### Danger:

**Danger** indicates a hazard with a high level of risk which, if not avoided, will result in death or serious injury.

### Warning:

**Warning** indicates a hazard with a medium level of risk which, if not avoided, could result in death or serious injury.

### Caution:

**Caution** indicates a hazard with a low level of risk which, if not avoided, could result in minor or moderate injury.

- 1) ISO 4414: Pneumatic fluid power – General rules and safety requirements for systems and their components.
- ISO 4413: Hydraulic fluid power – General rules and safety requirements for systems and their components.
- IEC 60204-1: Safety of machinery – Electrical equipment of machines. (Part 1: General requirements)
- ISO 10218-1: Robots and robotic devices - Safety requirements for industrial robots - Part 1: Robots.
- etc.

## Warning

### 1. The compatibility of the product is the responsibility of the person who designs the equipment or decides its specifications.

Since the product specified here is used under various operating conditions, its compatibility with specific equipment must be decided by the person who designs the equipment or decides its specifications based on necessary analysis and test results. The expected performance and safety assurance of the equipment will be the responsibility of the person who has determined its compatibility with the product. This person should also continuously review all specifications of the product referring to its latest catalogue information, with a view to giving due consideration to any possibility of equipment failure when configuring the equipment.

### 2. Only personnel with appropriate training should operate machinery and equipment.

The product specified here may become unsafe if handled incorrectly. The assembly, operation and maintenance of machines or equipment including our products must be performed by an operator who is appropriately trained and experienced.

### 3. Do not service or attempt to remove product and machinery/equipment until safety is confirmed.

1. The inspection and maintenance of machinery/equipment should only be performed after measures to prevent falling or runaway of the driven objects have been confirmed.
2. When the product is to be removed, confirm that the safety measures as mentioned above are implemented and the power from any appropriate source is cut, and read and understand the specific product precautions of all relevant products carefully.
3. Before machinery/equipment is restarted, take measures to prevent unexpected operation and malfunction.

### 4. Our products cannot be used beyond their specifications. Our products are not developed, designed, and manufactured to be used under the following conditions or environments. Use under such conditions or environments is not covered.

1. Conditions and environments outside of the given specifications, or use outdoors or in a place exposed to direct sunlight.
2. Use for nuclear power, railways, aviation, space equipment, ships, vehicles, military application, equipment affecting human life, body, and property, fuel equipment, entertainment equipment, emergency shut-off circuits, press clutches, brake circuits, safety equipment, etc., and use for applications that do not conform to standard specifications such as catalogues and operation manuals.
3. Use for interlock circuits, except for use with double interlock such as installing a mechanical protection function in case of failure. Please periodically inspect the product to confirm that the product is operating properly.

## Caution

**We develop, design, and manufacture our products to be used for automatic control equipment, and provide them for peaceful use in manufacturing industries.**

**Use in non-manufacturing industries is not covered.**

Products we manufacture and sell cannot be used for the purpose of transactions or certification specified in the Measurement Act.

The new Measurement Act prohibits use of any unit other than SI units in Japan.

## Limited warranty and Disclaimer/Compliance Requirements

The product used is subject to the following “Limited warranty and Disclaimer” and “Compliance Requirements”. Read and accept them before using the product.

### Limited warranty and Disclaimer

1. The warranty period of the product is 1 year in service or 1.5 years after the product is delivered, whichever is first. <sup>2)</sup> Also, the product may have specified durability, running distance or replacement parts. Please consult your nearest sales branch.
2. For any failure or damage reported within the warranty period which is clearly our responsibility, a replacement product or necessary parts will be provided. This limited warranty applies only to our product independently, and not to any other damage incurred due to the failure of the product.
3. Prior to using SMC products, please read and understand the warranty terms and disclaimers noted in the specified catalogue for the particular products.
- 2) Vacuum pads are excluded from this 1 year warranty.  
A vacuum pad is a consumable part, so it is warranted for a year after it is delivered. Also, even within the warranty period, the wear of a product due to the use of the vacuum pad or failure due to the deterioration of rubber material are not covered by the limited warranty.

### Compliance Requirements

1. The use of SMC products with production equipment for the manufacture of weapons of mass destruction (WMD) or any other weapon is strictly prohibited.
2. The exports of SMC products or technology from one country to another are governed by the relevant security laws and regulations of the countries involved in the transaction. Prior to the shipment of a SMC product to another country, assure that all local rules governing that export are known and followed.

## Safety Instructions

Be sure to read “Handling Precautions for SMC Products” (M-E03-3) before using.

## SMC Corporation (Europe)

<b>Austria</b>	+43 (0)2262622800	www.smc.at	office@smc.at
<b>Belgium</b>	+32 (0)33551464	www.smc.be	info@smc.be
<b>Bulgaria</b>	+359 (0)2807670	www.smc.bg	office@smc.bg
<b>Croatia</b>	+385 (0)13707288	www.smc.hr	office@smc.hr
<b>Czech Republic</b>	+420 541424611	www.smc.cz	office@smc.cz
<b>Denmark</b>	+45 70252900	www.smc.dk.com	smc@smcdk.com
<b>Estonia</b>	+372 651 0370	www.smcee.ee	info@smcee.ee
<b>Finland</b>	+358 207513513	www.smc.fi	smcfi@smc.fi
<b>France</b>	+33 (0)164761000	www.smc-france.fr	supportclient@smc-france.fr
<b>Germany</b>	+49 (0)61034020	www.smc.de	info@smc.de
<b>Greece</b>	+30 210 2717265	www.smchellas.gr	sales@smchellas.gr
<b>Hungary</b>	+36 23513000	www.smc.hu	office@smc.hu
<b>Ireland</b>	+353 (0)14039000	www.smcautomation.ie	sales@smcautomation.ie
<b>Italy</b>	+39 03990691	www.smcitalia.it	mailbox@smcitalia.it
<b>Latvia</b>	+371 67817700	www.smc.lv	info@smc.lv

<b>Lithuania</b>	+370 5 2308118	www.smclt.lt	info@smclt.lt
<b>Netherlands</b>	+31 (0)205318888	www.smc.nl	info@smc.nl
<b>Norway</b>	+47 67129020	www.smc-norge.no	post@smc-norge.no
<b>Poland</b>	+48 222119600	www.smc.pl	sales@smc.pl
<b>Portugal</b>	+351 214724500	www.smc.eu	apoioclientept@smc.smces.es
<b>Romania</b>	+40 213205111	www.smcromania.ro	smcromania@smcromania.ro
<b>Russia</b>	+7 (812)3036600	www.smc.eu	sales@smcru.com
<b>Slovakia</b>	+421 (0)413213212	www.smc.sk	office@smc.sk
<b>Slovenia</b>	+386 (0)73885412	www.smc.si	office@smc.si
<b>Spain</b>	+34 945184100	www.smc.eu	post@smc.smces.es
<b>Sweden</b>	+46 (0)86031240	www.smc.nu	smc@smc.nu
<b>Switzerland</b>	+41 (0)523963131	www.smc.ch	info@smc.ch
<b>Turkey</b>	+90 212 489 0 440	www.smcturkey.com.tr	info@smcturkey.com.tr
<b>UK</b>	+44 (0)845 121 5122	www.smc.uk	sales@smc.uk

**South Africa** +27 10 900 1233    www.smcza.co.za    zasales@smcza.co.za