

Fieldbus System

(For Input/Output)

Type 3 Integrated input-output type

- Enclosure IP67
- Maximum 32 inputs/32 outputs
- Sensors with M8/M12 connectors can be connected.

<Compatible Protocols>

Made to Order



Manifold Solenoid Valves

SY3000/5000/7000 Series

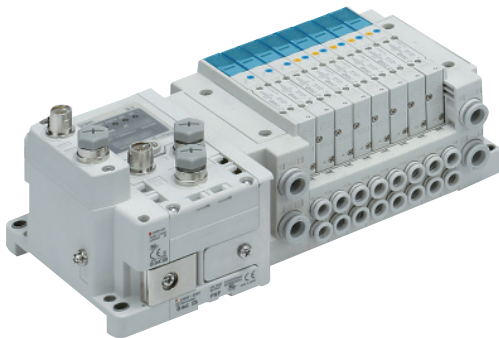

VQC1000/2000/4000/5000 Series

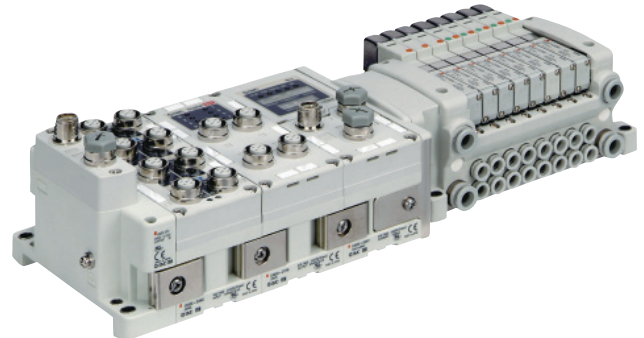

S0700 Series



SV1000/2000/3000 Series

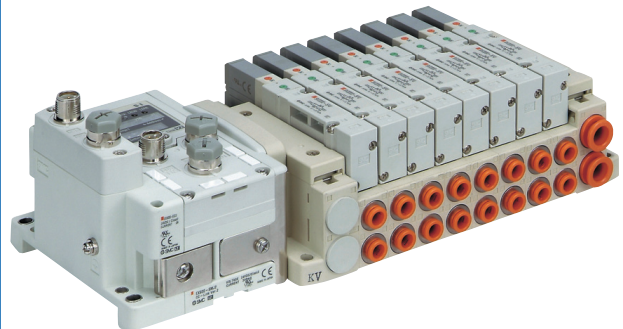

EX250 Series

CONTENTS

Type 3 Integrated input-output type

Fieldbus System (For Input/Output) EX250 Series

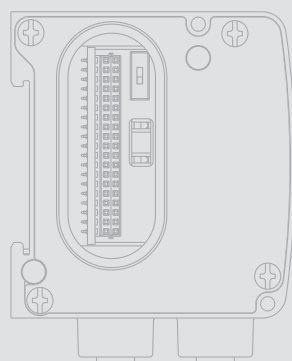
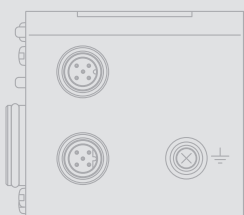
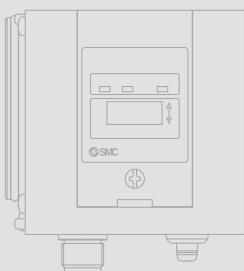

Parts Structure	p. 2
SI Unit	
How to Order	p. 2
Specifications	p. 3
Dimensions/Parts Description	p. 4
LED Indicator	p. 6

Input Block	
How to Order	p. 7
Specifications	p. 7
Dimensions/Parts Description	p. 8
LED Indicator	p. 9
Internal Circuit	p. 9

Accessories	
Example of Connections	p. 10
① Replacement Fuse	p. 11
② End Plate (Input side)	p. 11
③ Output Block	p. 12
④ Power Block	p. 12
⑤ End Plate (Output side)	p. 15
⑥ Communication Cable	p. 16
⑦ Field-wireable Communication Connector	p. 18
⑧ Power Supply Cable (For SI unit/For power block)	p. 18
⑧ Power Supply Cable (For SI unit)	p. 19
⑨ Cable for Output Entry	p. 19
⑩ Seal Cap (10 pcs.)	p. 19
⑪ Power Supply Cable (For connecting the SI unit to the power block)	p. 20
⑫ AS-Interface Power Supply Cable	p. 20

Made to Order	
① DeviceNet™, 7/8 inch connector, Occupied points: 48 inputs/32 outputs	p. 21
Communication Cable	p. 21
Power Supply Cable	p. 22

Specific Product Precautions	p. 23
------------------------------------	-------

Fieldbus System For Input/Output

EX250 Series



* Only the SY and SV valves are UL-compliant.

Parts Structure

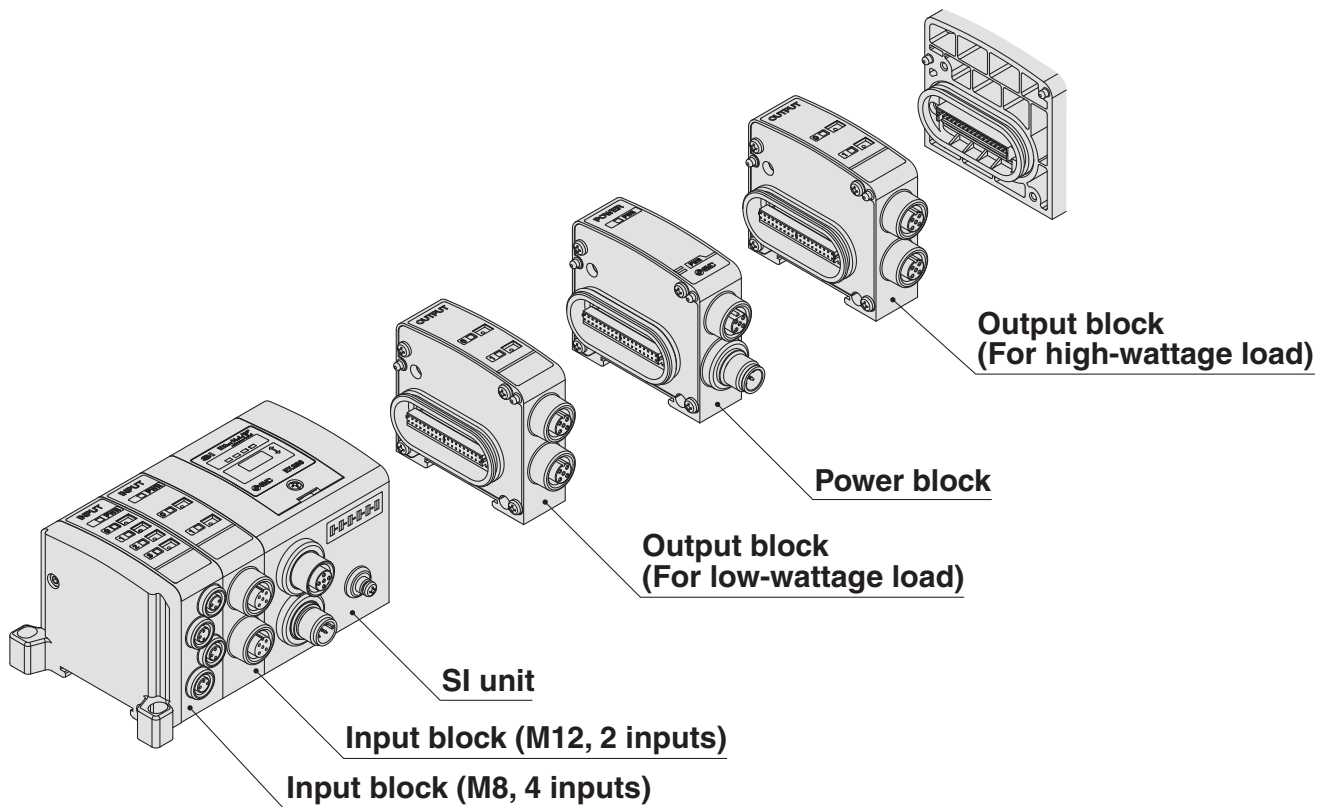

SI Unit

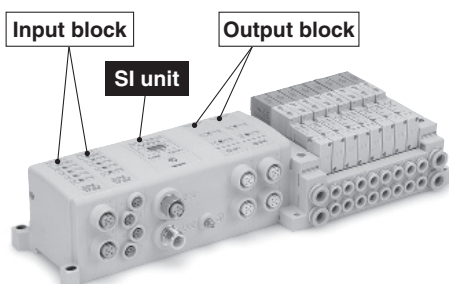
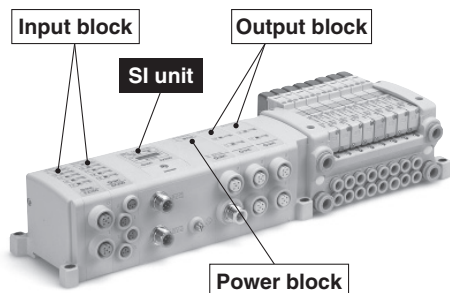

How to Order

EX250 - S **DN1** -

• Made to Order → p. 21
DeviceNet™ 7/8 inch connector

• Protocol

DN1 ^{*1}	DeviceNet™
DN1-X102 ^{*1}	DeviceNet™
PR1	PROFIBUS DP
AS3	AS-Interface (8in/8out 31 Slave Mode, 2 power supply systems)
AS5	AS-Interface (4in/4out 31 Slave Mode, 2 power supply systems)
AS7	AS-Interface (8in/8out 31 Slave Mode, 1 power supply system)
AS9	AS-Interface (4in/4out 31 Slave Mode, 1 power supply system)
CA1A	CANopen
EN1	EtherNet/IP™

*1 DN1's occupied points are 32 inputs and 32 outputs, while DN1-X102 has 48 inputs and 32 outputs.

EX250 Series

Specifications

Model		EX250-SDN1	EX250-SDN1-X102 ^{*1}	EX250-SPR1	EX250-SCA1A	EX250-SEN1	EX250-SAS3/5	EX250-SAS7/9
Communication	Applicable system	DeviceNet™		PROFIBUS DP	CANopen	EtherNet/IP™	AS-Interface	
	Protocol Version ^{*2}	Release 2.0		DP-V0	CiA DS-301 V4.02 CiA DS-401	Release 1.0	Ver. 2.11 (Standard Address Mode)	
	Communication speed	125 k/250 k/500 kbps		9.6 k/19.2 k/ 45.45 k/93.75 k/ 187.5 k/500 k/ 1.5 M/3 M/6 M/ 12 Mbps	10 k/20 k/50 k/ 125 k/250 k/ 500 k/800 k/ 1 Mbps	10 M/100 Mbps	167 kbps	
	Configuration file ^{*3}	EDS file		GSD file	EDS file	EDS file	—	—
	I/O occupation area (Inputs/Outputs)	32/32	48/32	32/32	32/32	48/32	SAS3: 8/8 (2 slave units) SAS5: 4/4	SAS7: 8/8 (2 slave units) SAS9: 4/4
	Applicable function	QuickConnect™		—	—	—	—	—
	Terminating resistor	Not provided				Not provided (Not required)		
Power supply voltage	For control	11 to 25 VDC (Supplied by DeviceNet™ circuit)		24 VDC ±20 %	18 V to 30 VDC (Supplied by CANopen circuit)	24 VDC ±20 %	26.5 to 31.6 VDC (Supplied by AS-i circuit)	^{*4} 26.5 to 31.6 VDC (Supplied by AS-i circuit)
	For sensors	24 VDC ±20 %			24 VDC ±20 %			
	For valve	24 VDC +10 %/-5 %						
Internal current consumption (Unit)		100 mA or less				SAS3: 100 mA or less SAS5: 65 mA or less	SAS7: 100 mA or less SAS9: 65 mA or less	
Input	Number of inputs	32 inputs (Based on input block connection)				SAS3: 8 inputs SAS5: 4 inputs	SAS7: 8 inputs SAS9: 4 inputs	
	Supply voltage	24 VDC						
	Supply current	1.0 A or less				SAS3: 240 mA or less SAS5: 120 mA or less	^{*5}	
Output	Output type	Source/PNP (Negative common)						
	Number of outputs	32 outputs				SAS3: 8 outputs SAS5: 4 outputs	SAS7: 8 outputs SAS9: 4 outputs	
	Load	Solenoid valve with surge voltage suppressor 24 VDC, 1.5 W or less (SMC) Output block Power block						
	Supply voltage	24 VDC						
	Supply current	2.0 A or less				SAS3: 500 mA or less SAS5: 250 mA or less	^{*5}	
	Fail safe	HOLD/CLEAR (Switch setting)		CLEAR	HOLD/CLEAR (Switch setting)			
Environmental resistance	Enclosure	IP67						
	Operating temperature range	5 to +45 °C			-10 to +50 °C	5 to +45 °C		
	Operating humidity range	35 to 85 %RH (No condensation)						
	Withstand voltage	500 VAC for 1 minute between whole external terminal and FG						
	Insulation resistance	10 MΩ or more (500 VDC) between whole external terminal and FG						
Standards	CE/UKCA marking (EMC directive/RoHS directive), UL (CSA)							
Weight	250 g							
Accessory ^{*6}	Tie-rod 2 pcs.							

^{*1} This is a specification to transmit the diagnostic information of voltage drop of the valve power supply and input block fuse blowout as an input data to the master. The EX250-SDN1 becomes I/O connection time out when the diagnostic information is detected, but not EX250-SDN1-X102. Since this is a special product, a manifold part number is not specified. Please consult SMC for the manifold integrated type.

^{*2} Please note that the version is subject to change.

^{*3} The setting file can be downloaded from SMC website, <http://www.smc.eu>

^{*4} Since the EX250-SAS7/9 is compatible with the 1 power supply system, the power supply for units is divided into two: the power supply for sensors and for valves.

^{*5} Since the EX250-SAS7/9 is compatible with the 1 power supply system, the power supply must be divided in accordance with the values below. (Refer to page 23 for details.)

EX250-SAS7 ... Max. 240 mA, EX250-SAS9 ... Max. 120 mA

^{*6} When the SI unit is mounted to the manifold when shipped, accessories are shipped together with it.

^{*7} For detailed specifications other than the above, refer to the operation manual that can be downloaded from SMC website, <http://www.smc.eu>

Dimensions/Parts Description

EX250-SDN1 (DeviceNet™)

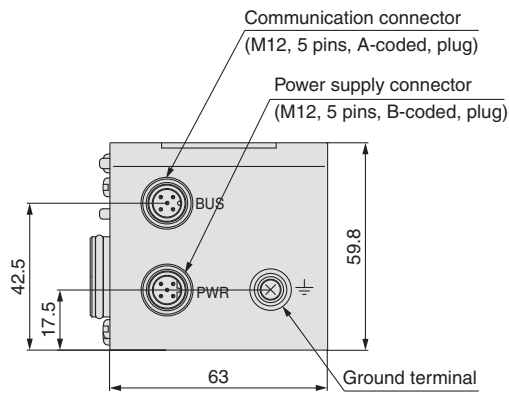

EX250-SPR1 (PROFIBUS DP)

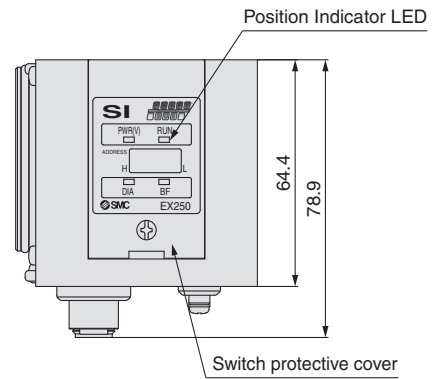
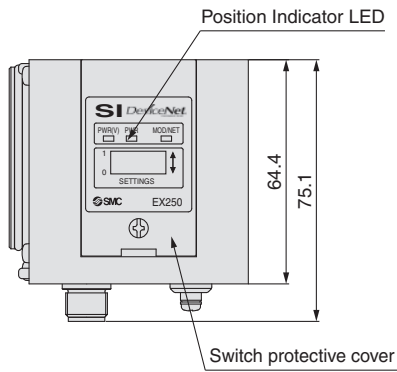
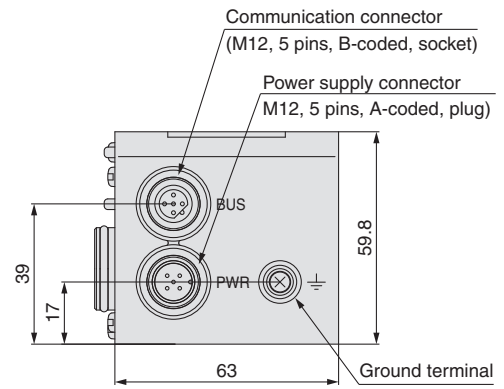

EX250 Series

Dimensions/Parts Description

EX250-SCA1A (CANopen)

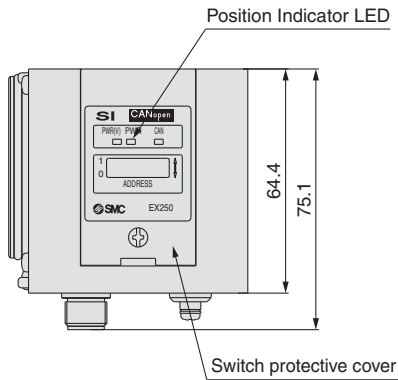
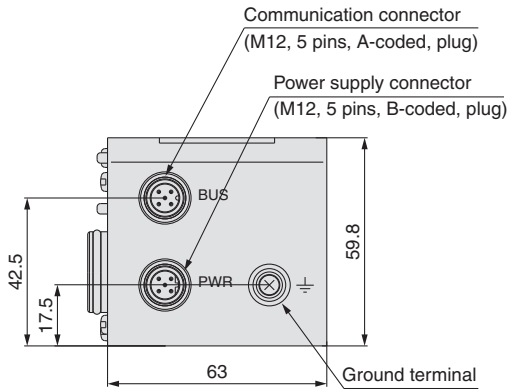

EX250-SEN1 (EtherNet/IP™)

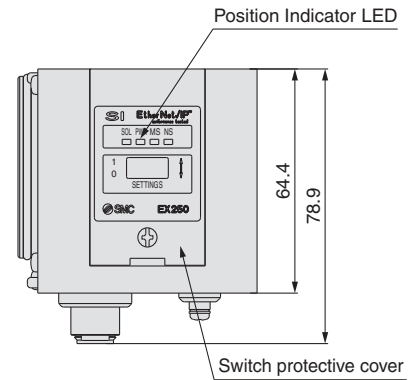
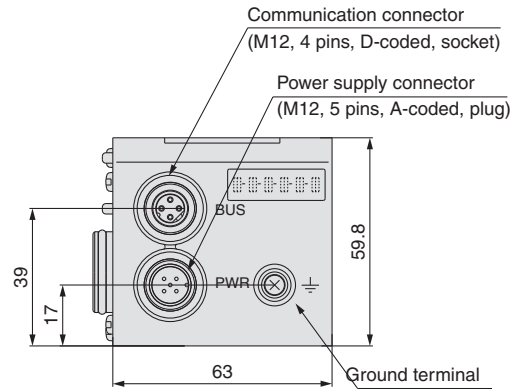

EX250-SAS7/9 (AS-Interface 1 power supply system)

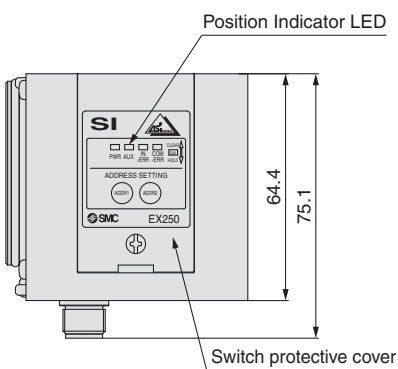
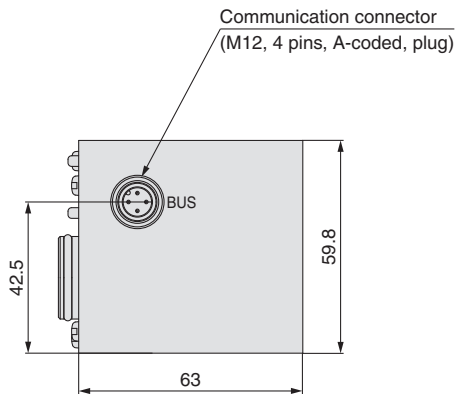

EX250-SAS3/5 (AS-Interface 2 power supply systems)

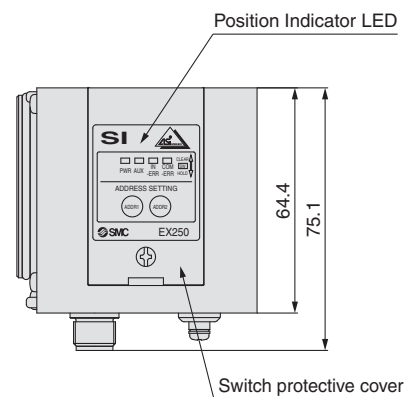
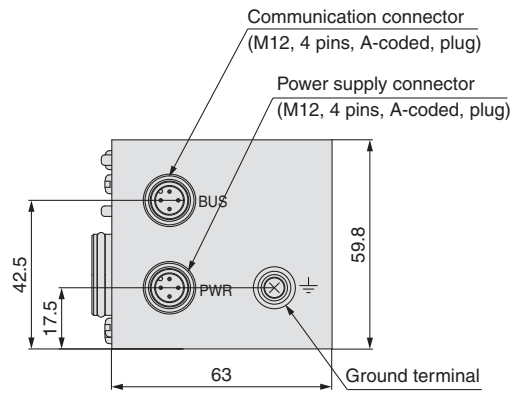

LED Indicator

EX250-SDN1 (DeviceNet™)

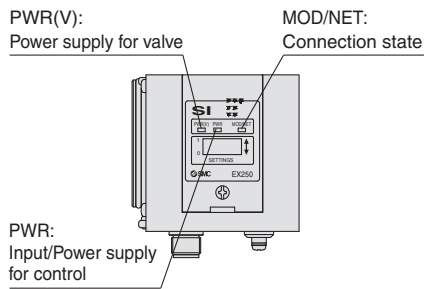

EX250-SPR1 (PROFIBUS DP)

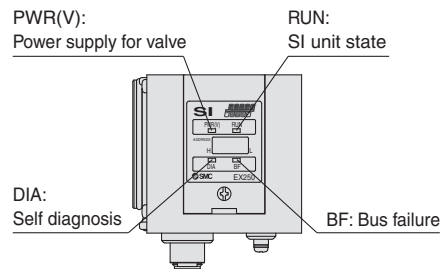

EX250-SCA1A (CANopen)

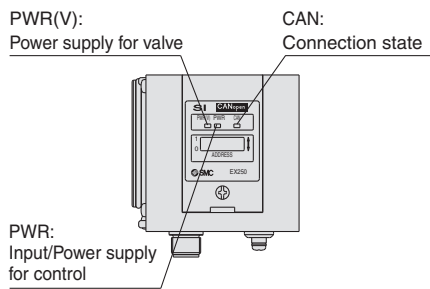

EX250-SEN1 (EtherNet/IP™)

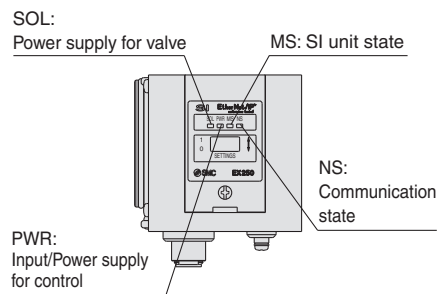

EX250-SAS7/9 (AS-Interface 1 power supply system)

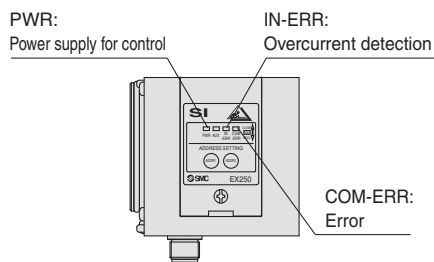

EX250-SAS3/5 (AS-Interface 2 power supply systems)

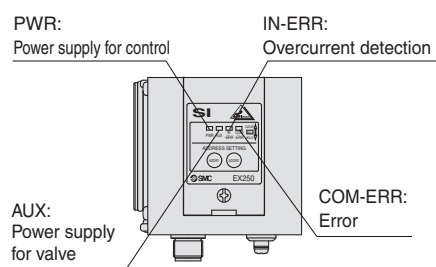

EX250 Series

How to Order

Input Block

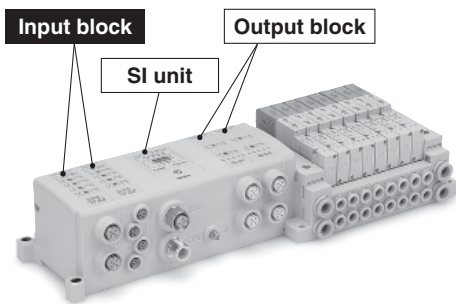
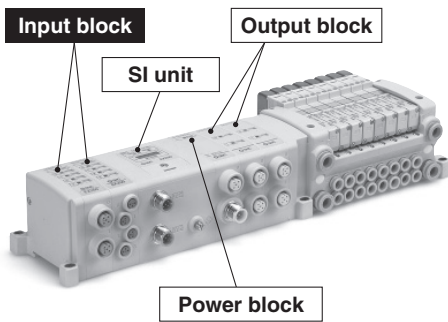

EX250-IE 1

Block type

1	M12 connector, 2 inputs
2	M12 connector, 4 inputs
3	M8 connector, 4 inputs

For accessory, refer to pages 10 to 20.

Specifications

Model		EX250-IE1	EX250-IE2	EX250-IE3
Input	Input type	PNP/NPN sensor input (switched using a switch)		
	Number of inputs	2 inputs	4 inputs	
	Input device supply voltage	24 VDC		
	Input device supply current	Max. 30 mA/Point*1		
	Rated input current	Approx. 8 mA		
Environmental resistance	Enclosure	IP67		
	Operating temperature range	-10 to +50 °C		
	Operating humidity range	35 to 85 %RH (No condensation)		
	Withstand voltage	500 VAC for 1 minute between whole external terminal and FG		
Insulation resistance	10 MΩ or more (500 VDC) between whole external terminal and FG			
Standards	CE/UKCA marking, UL (CSA)			
Weight	90 g			
Accessory*2	Tie-rod 2 pcs.			

*1 When the maximum inputs to the SI unit is reached by adding an input block, pay attention not to exceed the supply current for the SI unit input.

*2 When the SI unit is integrated into manifold, its tie-rod is also incorporated at the time of shipment.

* For detailed specifications other than the above, refer to the operation manual that can be downloaded from SMC website, <http://www.smc.eu>

Dimensions/Parts Description

EX250-IE1, EX250-IE2

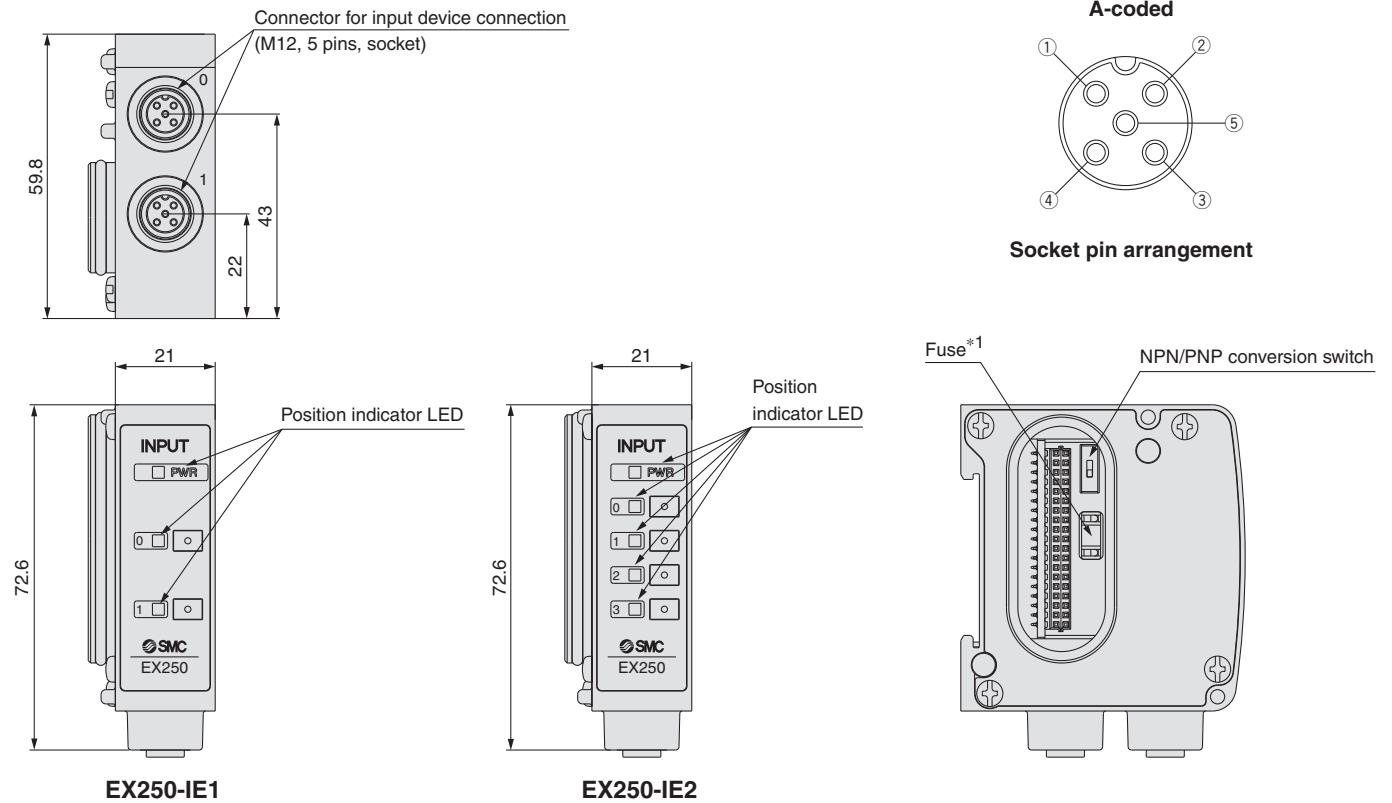

EX250-IE3

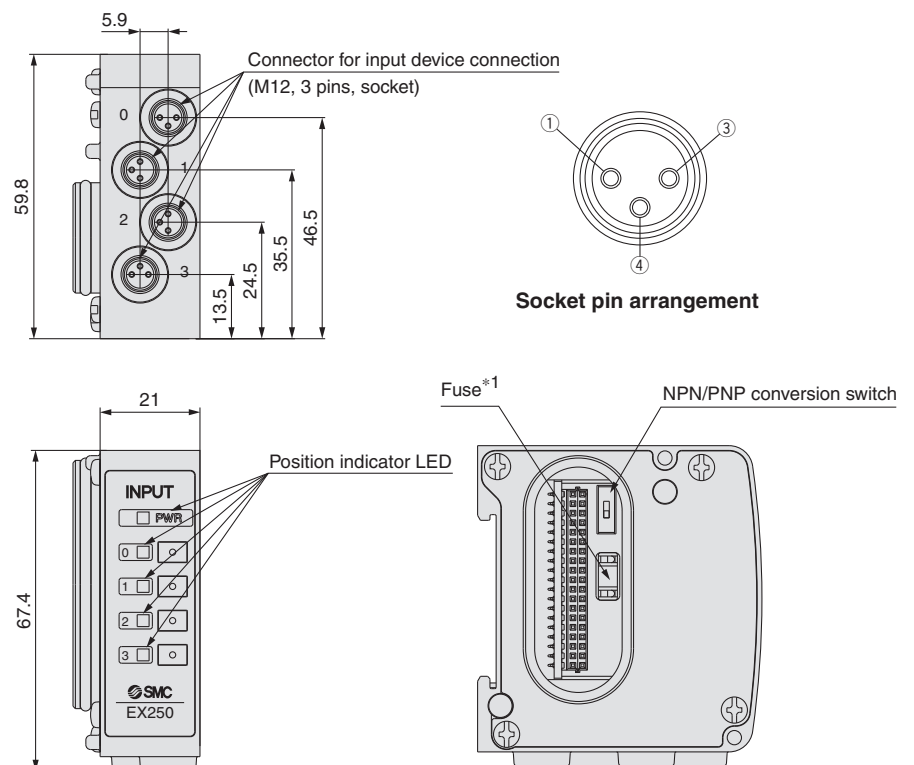

*1 Fuse for overcurrent protection

If addressing the possible cause of a problem, even when the fuse is blown, it can be reinstated by replacing with a fuse as shown in options, page 21.

EX250 Series

LED Indicator

EX250-IE1

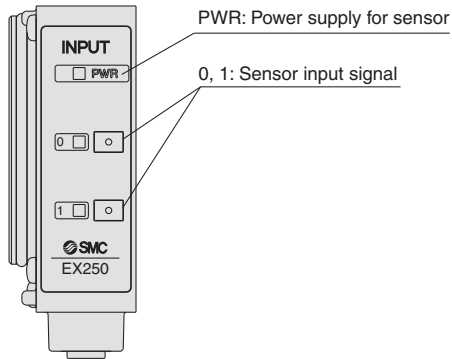

EX250-IE2

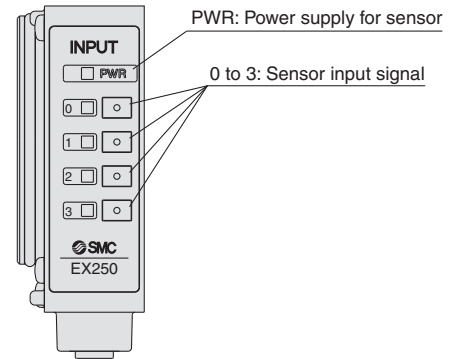

EX250-IE3

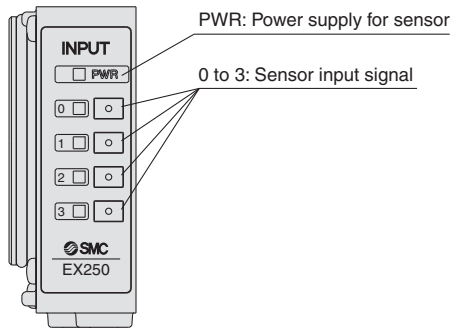

Internal Circuit

EX250-IE1

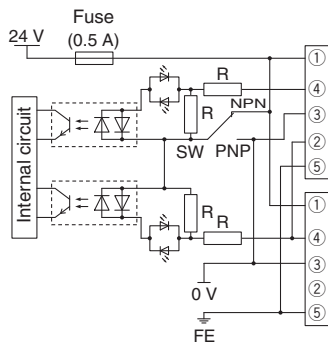

EX250-IE2

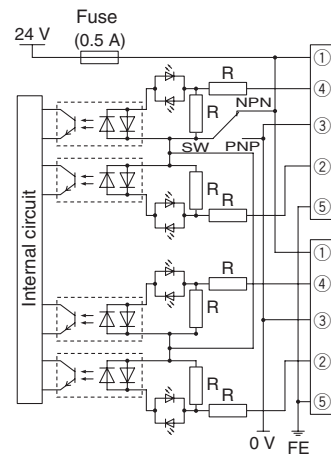

EX250-IE3

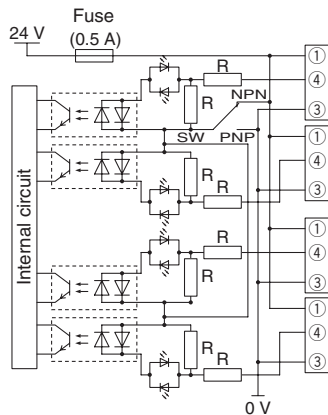

EX250 Series Accessories

Example of Connections

Connection example of an SI unit compatible with DeviceNet™, CANopen

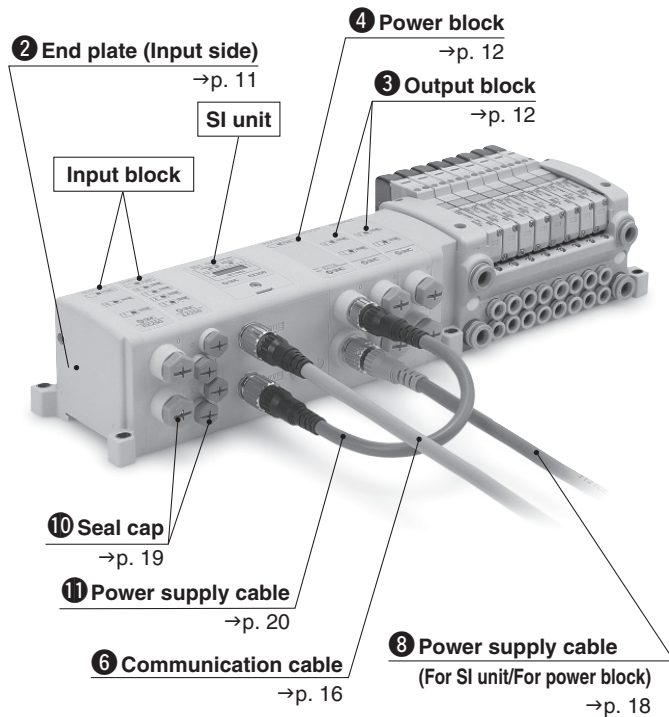

* The SI unit pictured above is compatible with DeviceNet™.

Connection example of an SI unit compatible with EtherNet/IP™, PROFIBUS DP

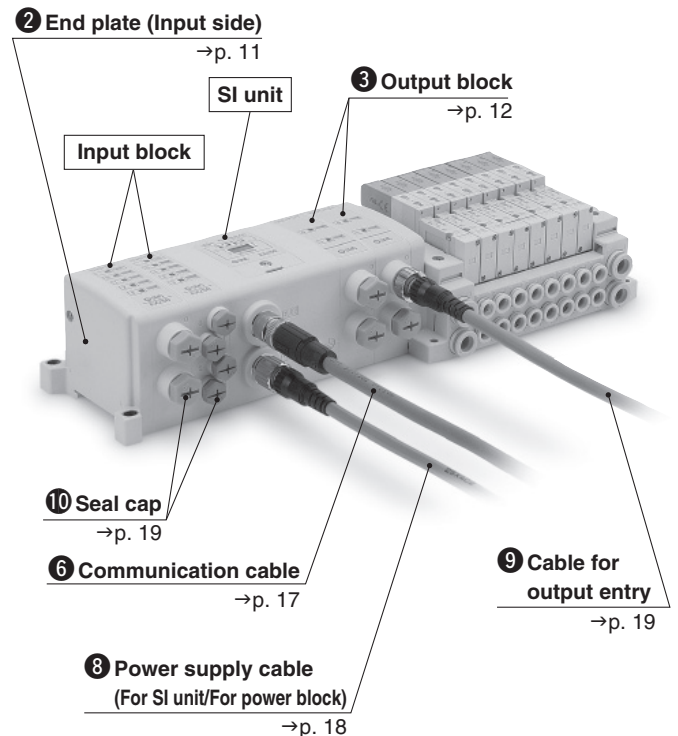

* The SI unit pictured above is compatible with PROFIBUS DP.

Connection example of an SI unit compatible with AS-Interface

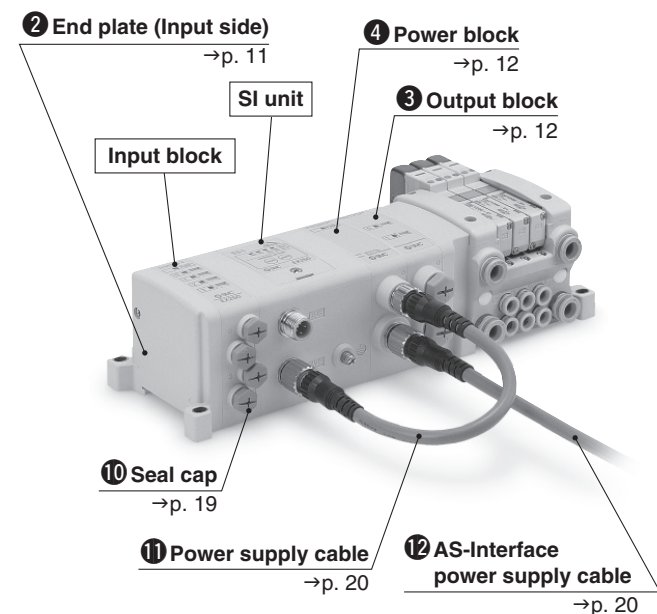

EX250 Series

① Replacement Fuse

Replacement fuse required when the fuse for the input block (EX250-IE□) overcurrent protection is blown.

EX9-FU05

Model	EX9-FU05
Applicable model	EX250-IE□
Rated current	0.5 A
Rated insulation capacity	48 VAC/DC 50 A
Fuse resistance value	0.36 Ω

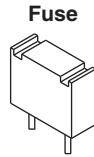

② End Plate (Input side)

EX250-EA 1

● Mounting specification

1	Direct mounting
2	DIN rail mounting

Accessory
Hexagon socket head cap screw (M3 x 10): 2 pcs.

<Example of use>

End plate (Input side)



EX250-EA1

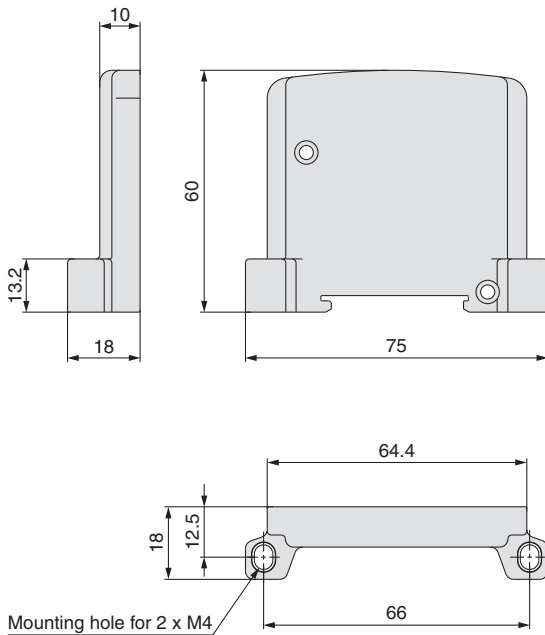

EX250-EA2

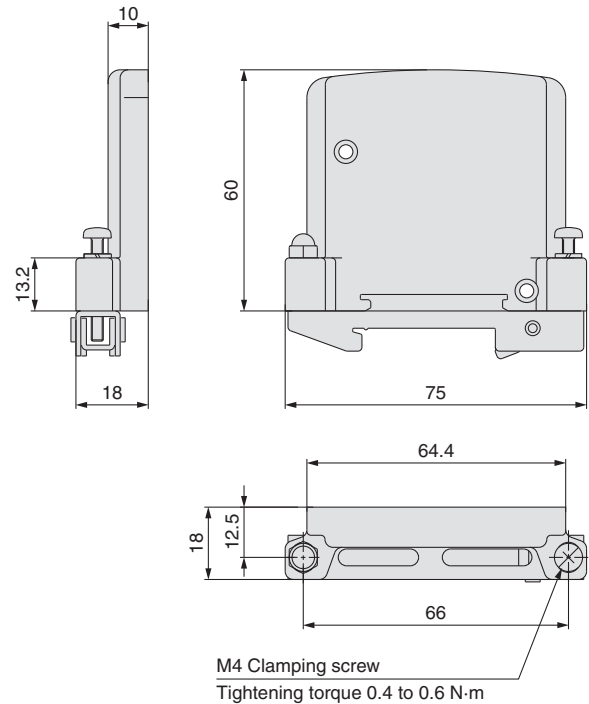

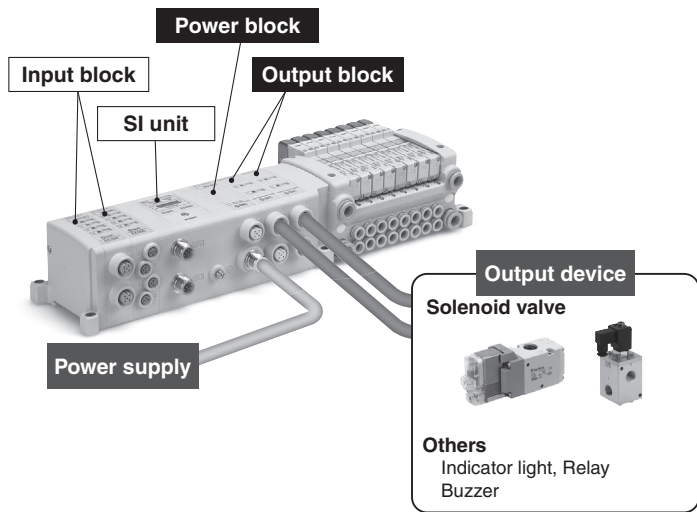

- Able to retrofit to the valve manifold, using the unused points
- 2-output (M12 connector)
- Positive/Negative common available as standard
- Able to drive by 0.5 A per point

You are requested to connect it to an SI unit and a valve manifold. For detailed specifications, refer to the operation manual that can be downloaded from SMC website, <http://www.smc.eu>

3 Output Block

EX9-OE T 1

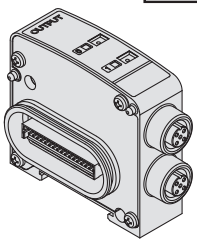

Output specification

1	Source/PNP (Negative common)
2	Sink/NPN (Positive common)

Power supply type

T	Internal power supply method (for low-wattage load)
P	Integrated power supply method (for high-wattage load)*1

*1 Required to connect with a power block

SI Unit/Part Nos.

SI unit part no.	Output	Applicable model
EX250-SDN1 EX250-SPR1 EX250-SAS□ EX250-SCA1A EX250-SEN1	Source/PNP (Negative common)	EX9-OET1 EX9-OEP1

Option/Part Nos.

Description	Part no.	Applicable model		Note
		OET□	OEP□	
Seal cap	EX9-AWTS	○	○	Refer to page 19. Order separately: 10 pcs. included
Cable for output entry	EX9-AC□-7	○	○	Refer to page 19. Order separately.
Power block	EX9-PE1		○	Refer to page 13. Order separately.

4 Power Block

EX9-PE1

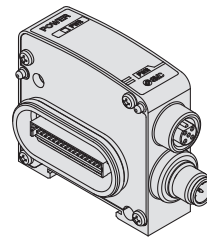

Option/Part Nos.

Description	Part no.	Note
Seal cap	EX9-AWTS	Refer to page 19. Order separately: 10 pcs. included
Power supply cable (For SI unit/For power block)	EX9-AC□-1	Refer to page 18. Order separately.
Power supply cable (For connecting the SI unit to the power block)	EX9-AC002-2 EX9-AC002-3 EX9-AC002-4	Refer to page 20. Order separately.
AS-Interface power supply cable	EX9-AC□-5	Refer to page 20. Order separately.

EX250 Series

③ Output Block/④ Power Block

Output Block Specifications

Model		EX9-OET1	EX9-OET2	EX9-OEP1	EX9-OEP2
Output connector		M12 connector (5 pins)			
Internal current consumption		40 mA or less			
Output	Output type	Source/PNP (Negative common)	Sink/NPN (Positive common)	Source/PNP (Negative common)	Sink/NPN (Positive common)
	Number of outputs	2 outputs			
	Power supply method	Internal power supply method		Integrated power supply method (Power block: supplied from EX9-PE1)	
	Output device supply voltage	24 VDC			
	Output device supply current	Max. 62 mA/Point (1.5 W/Point)		Max. 0.5 A/Point (12 W/Point)	
Environmental resistance	Enclosure	IP67			
	Operating temperature range	-10 to +50 °C			
	Operating humidity range	35 to 85 %RH (No condensation)			
	Withstand voltage	1500 VAC for 1 minute between whole external terminal and FG			
	Insulation resistance	10 MΩ or more (500 VDC) between whole external terminal and FG			
Standards		CE/UKCA marking, UL (CSA)			
Weight		120 g			
Accessory	Tie-rod	2 pcs.			

Power Block Specifications

Model		EX9-PE1
Connection block		Output block (EX9-OEP□)
Connection block stations		Output block: Max. 9 stations (excluding input blocks)*1
Power supply for output and internal control	Power supply voltage	22.8 to 26.4 VDC
	Internal power consumption	20 mA or less
Supply current		Max. 3.1 A (When using with 3.0 to 3.1 A, the ambient temperature should not exceed 40 °C, and do not bundle the cable.)
Environmental resistance	Enclosure	IP67
	Operating temperature range	-10 to +50 °C
	Operating humidity range	35 to 85 %RH (No condensation)
	Withstand voltage	1500 VAC for 1 minute between whole external terminal and FG
	Insulation resistance	10 MΩ or more (500 VDC) between whole external terminal and FG
Standards		CE/UKCA marking, UL (CSA)
Weight		120 g
Accessory	Tie-rod	2 pcs.
	Seal cap (for M12 connector socket)	1 pc. (EX9-AWTS)

*1 The total number of connectable input/output/power block to the EX250 series SI unit (except for AS-Interface compliant) is 10 stations at the maximum.

* For detailed specifications other than the above, refer to the operation manual that can be downloaded from SMC website, <http://www.smc.eu>

Output Block Dimensions/Parts Description

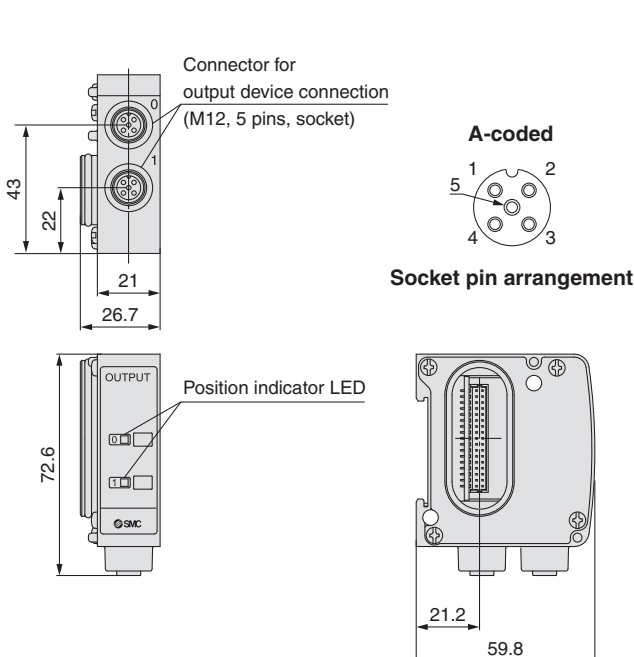

Power Block Dimensions/Parts Description

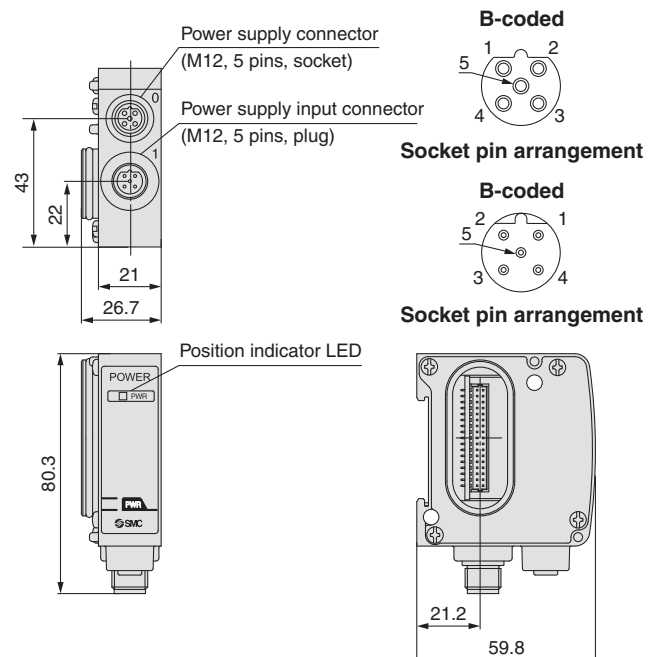

③ Output Block/④ Power Block

Circuit Diagram

EX9-OET1

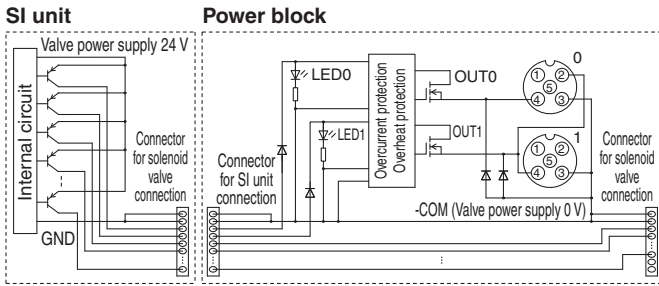

EX9-OET2

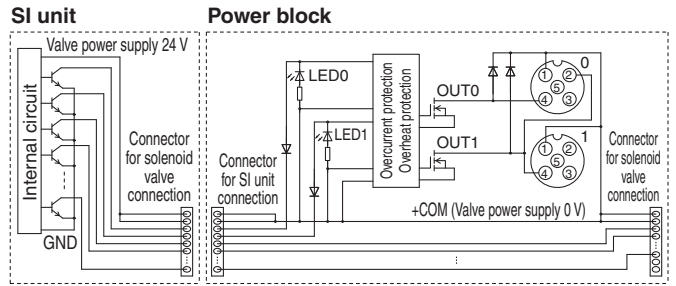

EX9-OEP1

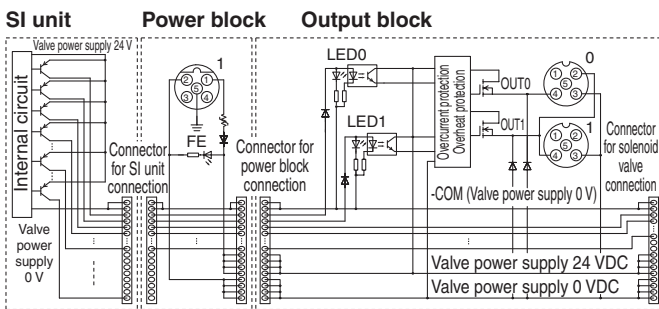

EX9-OEP2

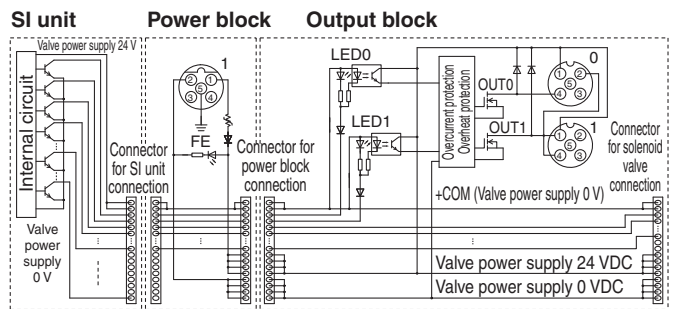

EX9-PE1

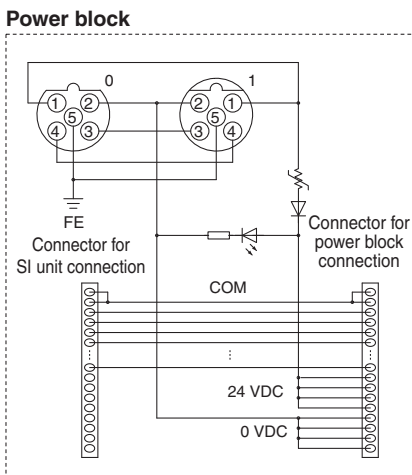

* When the valve which supplies power to the SI unit is turned OFF, the output of the output block (EX9-OE□) remains OFF.

EX250 Series

⑤ End Plate (Output side)

Use the end plate when a valve manifold is not connected.

EX9-EA 03

● Mounting specification

03	Direct mounting
04	DIN rail mounting

<Example of use>

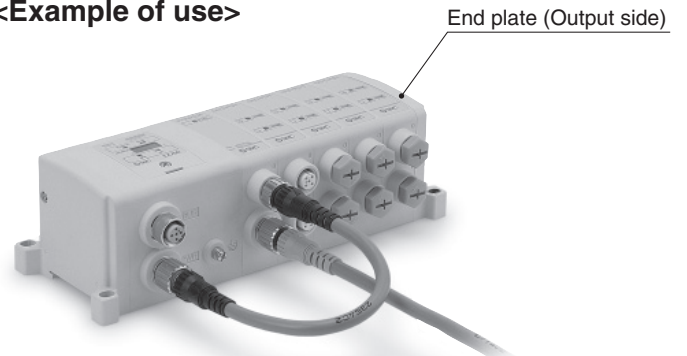

EX9-EA03

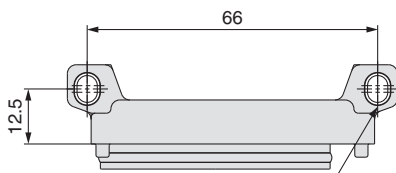
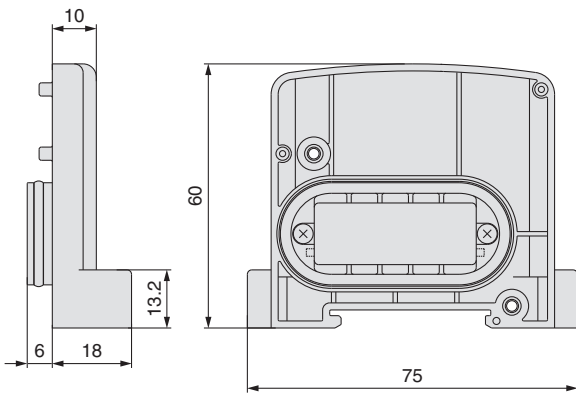

Mounting hole for 2 x M4

EX9-EA04

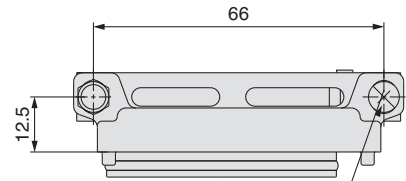
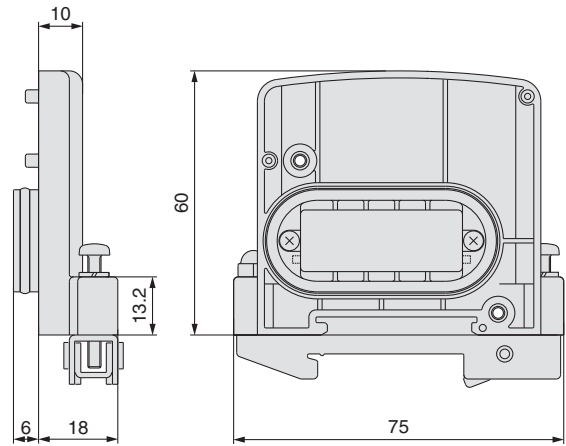

M4 Clamping screw
Tightening torque 0.4 to 0.6 N·m

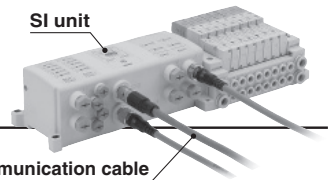

⑥ Communication Cable

For DeviceNet™ For CANopen

EX500-AC **050** -DN

• Cable length (L)

010	1000 mm
050	5000 mm

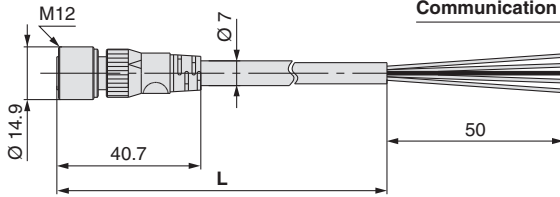

A-coded

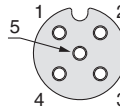

Socket pin arrangement

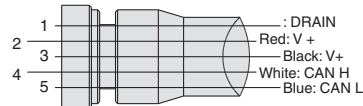

Connections

Item	Specifications
Cable O.D.	Ø 7 mm
Conductor nominal cross section	Power pair 0.33 mm ² /AWG22
	Data pair 0.2 mm ² /AWG24
Wire O.D. (Including insulator)	Power pair 1.5 mm
	Data pair 1.9 mm
Min. bending radius (Fixed)	60 mm

PCA-1557633

(Socket)

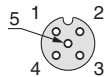

Socket connector pin arrangement A-coded (Normal key)

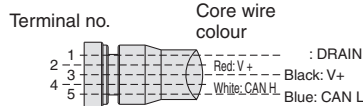
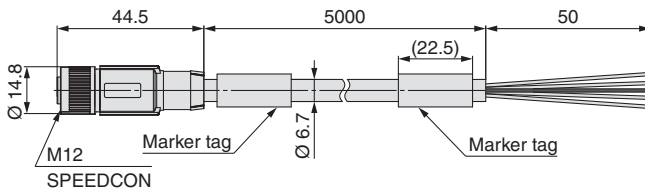

Connections

Item	Specifications
Cable O.D.	Ø 6.7 mm
Conductor nominal cross section	Power pair 0.32 mm ² /AWG22
	Data pair 0.2 mm ² /AWG24
Wire O.D. (Including insulator)	Power pair 1.4 mm
	Data pair 2.05 mm
Min. bending radius (Fixed)	67 mm



Made to Order

Cable length	10000 mm	p. 21
--------------	----------	-------

EX9-AC **005** EN-SSPS (With connector on both sides (Socket/Plug))

• Cable length (L)

005	500 mm
010	1000 mm
020	2000 mm
030	3000 mm
050	5000 mm
100	10000 mm

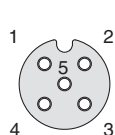
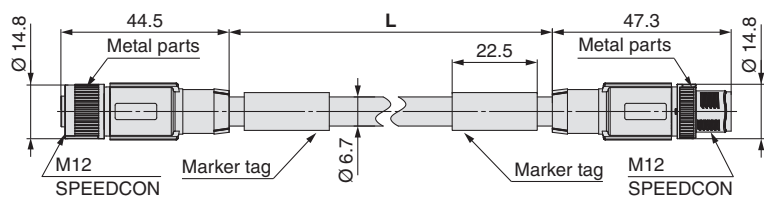

Socket connector pin arrangement A-coded (Normal key)

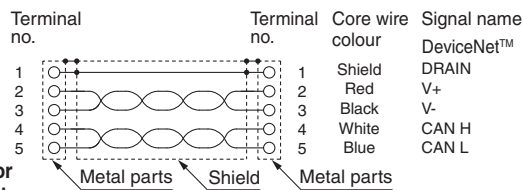

Connections

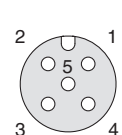

Plug connector pin arrangement A-coded (Normal key)

Item	Specifications
Cable O.D.	Ø 6.7 mm
Conductor nominal cross section	Power pair 0.34 mm ² /AWG22
	Data pair 0.25 mm ² /AWG24
Wire O.D. (Including insulator)	Power pair 1.4 mm
	Data pair 2.05 mm
Min. bending radius (Fixed)	67 mm

EX250 Series

⑥ Communication Cable

For PROFIBUS DP

PCA-1557691
(Plug)

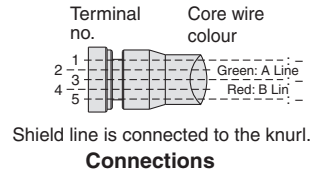
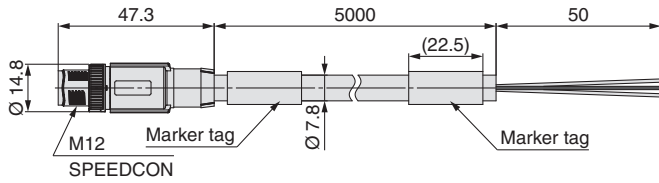
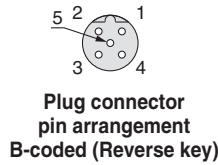

Item	Specifications
Cable O.D.	Ø 7.8 mm
Conductor nominal cross section	0.34 mm ² /AWG22
Wire O.D. (Including insulator)	2.55 mm
Min. bending radius (Fixed)	78 mm

For EtherNet/IP™

EX9-AC 020 EN-PSRJ (Plug/RJ-45 connector)

● Cable length (L)

010	1000 mm
020	2000 mm
030	3000 mm
050	5000 mm
100	10000 mm

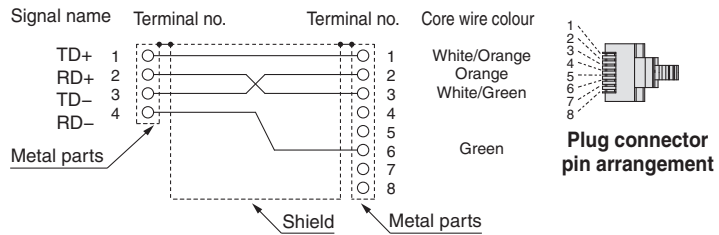
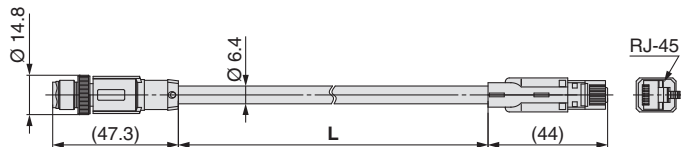
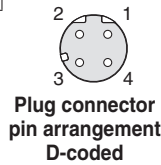

Item	Specifications
Cable O.D.	Ø 6.4 mm
Conductor nominal cross section	0.14 mm ² /AWG26
Wire O.D. (Including insulator)	0.98 mm
Min. bending radius (Fixed)	26 mm

EX9-AC 005 EN-PSPS (With connector on both sides (Plug/Plug))

● Cable length (L)

005	500 mm
010	1000 mm
020	2000 mm
030	3000 mm
050	5000 mm
100	10000 mm

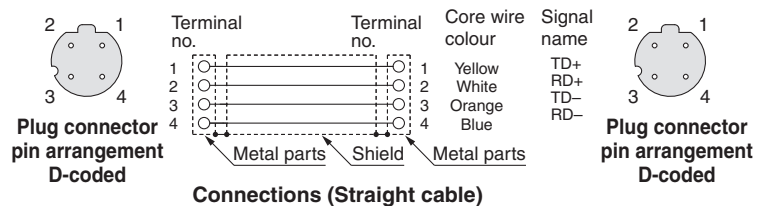
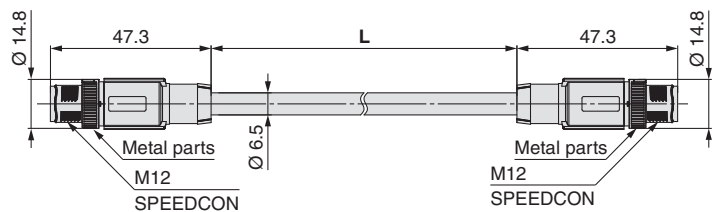

Item	Specifications
Cable O.D.	Ø 6.5 mm
Conductor nominal cross section	0.34 mm ² /AWG22
Wire O.D. (Including insulator)	1.55 mm
Min. bending radius (Fixed)	19.5 mm

7 Field-wireable Communication Connector

Plug

For DeviceNet™
For CANopen
PCA-1075528

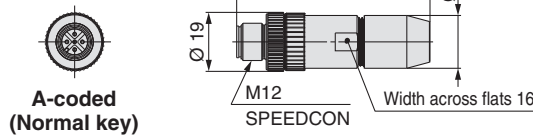

For PROFIBUS DP
PCA-1075530

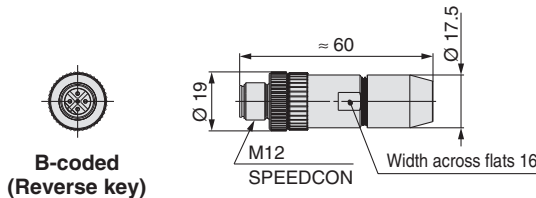

Applicable Cable

Item	Specifications
Cable O.D.	4.0 to 8.0 mm
Wire gauge (Stranded wire cross section)	0.14 to 0.75 mm ² /AWG26 to 18 (Solid cable/Flexible cable) 0.08 to 0.5 mm ² /AWG28 to 20 (With ferrule)

Socket

For DeviceNet™
For CANopen
PCA-1075529

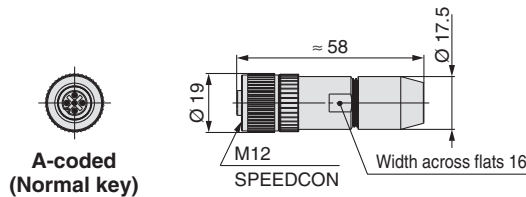

For PROFIBUS DP
PCA-1075531

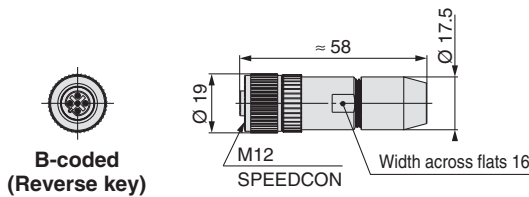

Applicable Cable

Item	Specifications
Cable O.D.	4.0 to 8.0 mm
Wire gauge (Stranded wire cross section)	0.14 to 0.75 mm ² /AWG26 to 18 (Solid cable/Flexible cable) 0.08 to 0.5 mm ² /AWG28 to 20 (With ferrule)

8 Power Supply Cable (For SI unit/For power block)

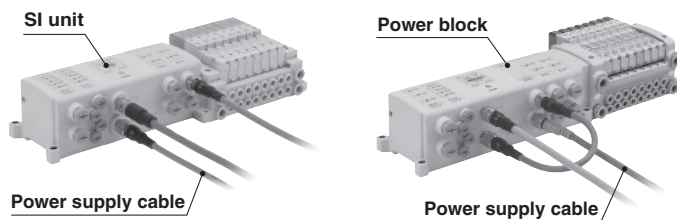

For DeviceNet™ For CANopen For Power block

Straight connector type

EX9-AC 050 -1

● Cable length (L)

010	1000 mm
030	3000 mm
050	5000 mm

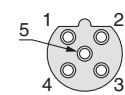

Socket connector pin arrangement B-coded

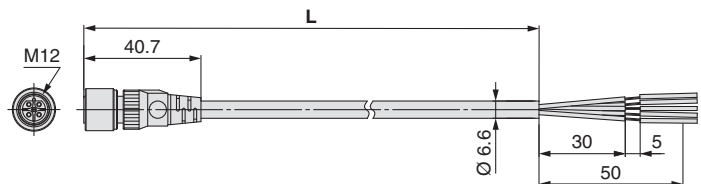

Item	Specifications
Cable O.D.	Ø 6.6 mm
Conductor nominal cross section	AWG22
Wire O.D. (Including insulator)	1.65 mm
Min. bending radius (Fixed)	40 mm



Made to Order

Cable length	10000 mm	p. 21
--------------	----------	-------

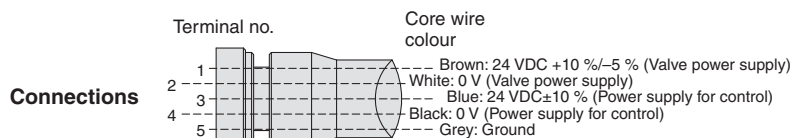

EX250 Series

⑧ Power Supply Cable (For SI unit)

For PROFIBUS DP For EtherNet/IP™

EX500-AP **050** -S

Cable length (L)

010	1000 mm
050	5000 mm

Connector specification

S	Straight
---	----------

Straight connector type

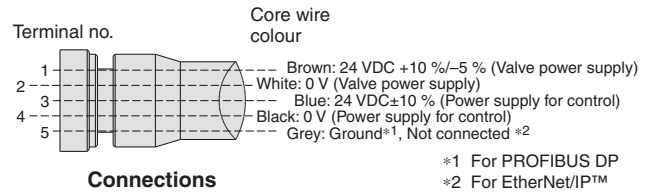
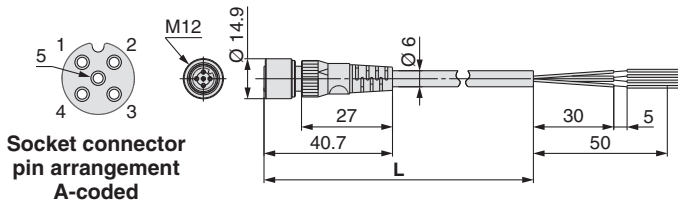

Item	Specifications
Cable O.D.	Ø 6 mm
Conductor nominal cross section	0.3 mm ² /AWG22
Wire O.D. (Including insulator)	1.5 mm
Min. bending radius (Fixed)	40 mm



Made to Order

Cable length	10000 mm	p. 22
--------------	----------	-------

⑨ Cable for Output Entry

Connects the output block to the output device

EX9-AC **030** -7

Cable length (L)

010	1000 mm
030	3000 mm

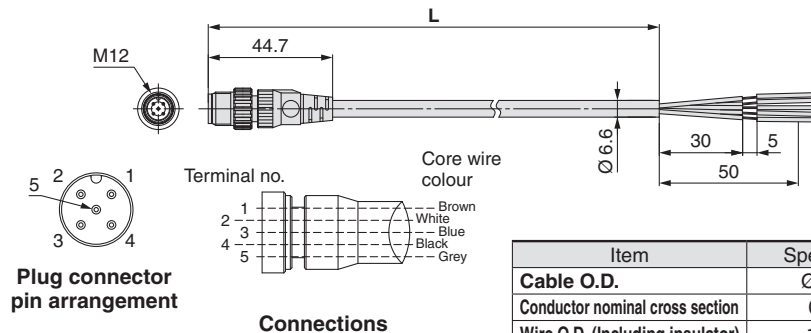
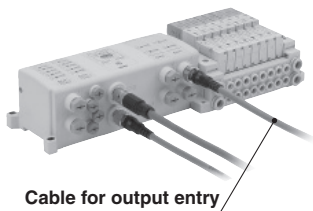

Item	Specifications
Cable O.D.	Ø 6.6 mm
Conductor nominal cross section	0.3 mm ²
Wire O.D. (Including insulator)	1.65 mm
Min. bending radius (Fixed)	40 mm

⑩ Seal Cap (10 pcs.)

Use this on ports that are not being used for an M8 or M12 connector (socket). Use of this seal cap maintains the integrity of the enclosure. (Seal caps are packed together with each unit.)

* Tighten the seal caps with the prescribed tightening torque. (For M8: 0.05 N·m, For M12: 0.1 N·m)

EX9-AW **ES**

Connector type

ES	M8 connector (For socket), 10 pcs.
TS	M12 connector (For socket), 10 pcs.

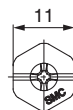
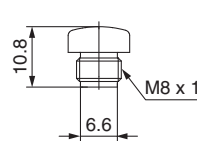
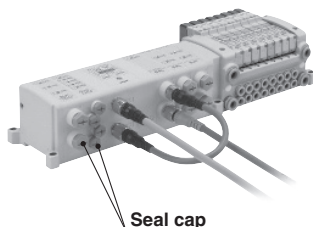

For M8 connector socket

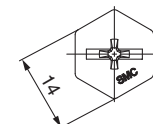
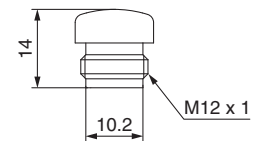

For M12 connector socket

① Power Supply Cable (For connecting the SI unit to the power block)

Connects between the power supply connector for the power block and the SI unit power supply connector, bridging the external power supply, which is supplied with the power block, to the SI unit.

EX9-AC002-2

SI unit type

2	EX250-SDN1 EX250-SCA1A	Compliant
3	EX250-SPR1 EX250-SEN1	Compliant
4	EX250-SAS3/5	Compliant

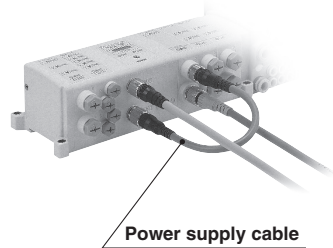

EX9-AC002-2

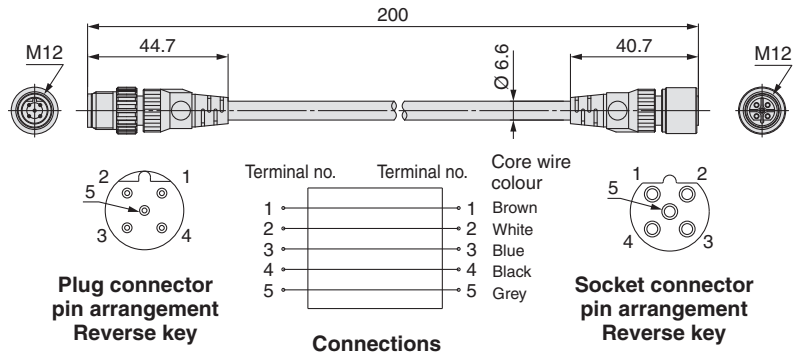

EX9-AC002-3

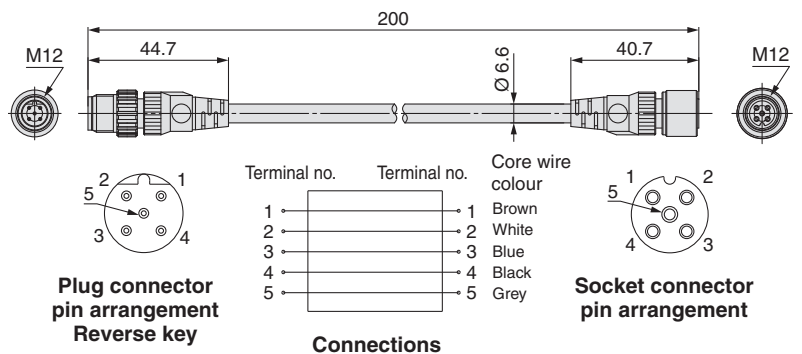

EX9-AC002-4

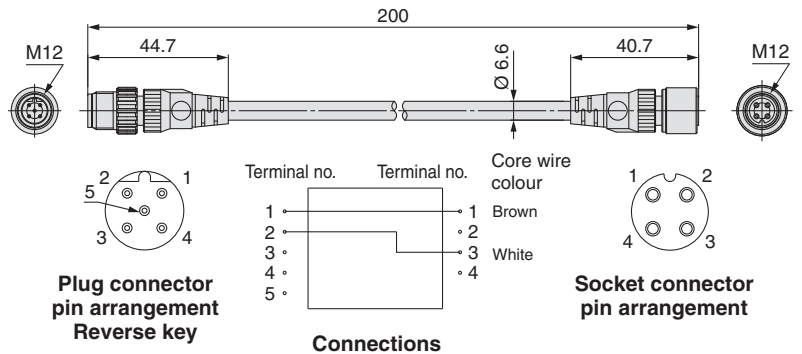

Item	Specifications
Cable O.D.	Ø 6.6 mm
Conductor nominal cross section	0.3 mm ²
Wire O.D. (Including insulator)	1.65 mm
Min. bending radius (Fixed)	40 mm

② AS-Interface Power Supply Cable

Cable connecting between AS-Interface power supply line (for external devices) branch connector (M12) and the power block's power supply input connector.

EX9-AC 010 -5

Cable length (L)

010	1000 mm
030	3000 mm
050	5000 mm

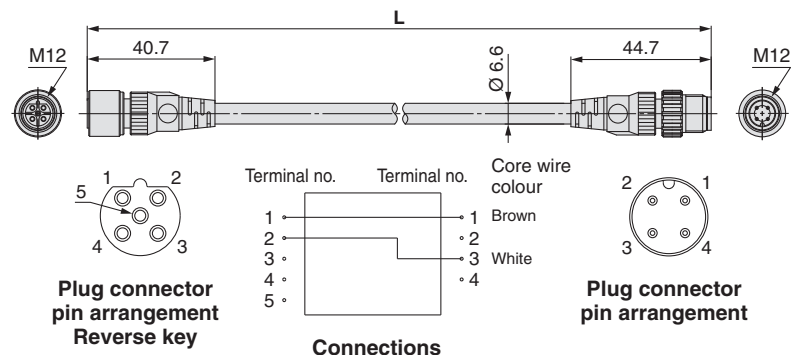
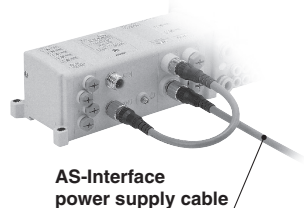

Item	Specifications
Cable O.D.	Ø 6.6 mm
Conductor nominal cross section	0.3 mm ²
Wire O.D. (Including insulator)	1.65 mm
Min. bending radius (Fixed)	40 mm

EX250 Series Made to Order

Please contact SMC for detailed specifications and lead times.

SI Unit

Prepare the SI unit, each type of block, and the manifold valve (without SI unit) separately, and combine them before use.

- ① DeviceNet™, 7/8 inch connector,
32 inputs/32 outputs
(Occupied points: 48 inputs (32 inputs + diagnostic 16 inputs)/32 outputs)

EX250-SDN1-X122

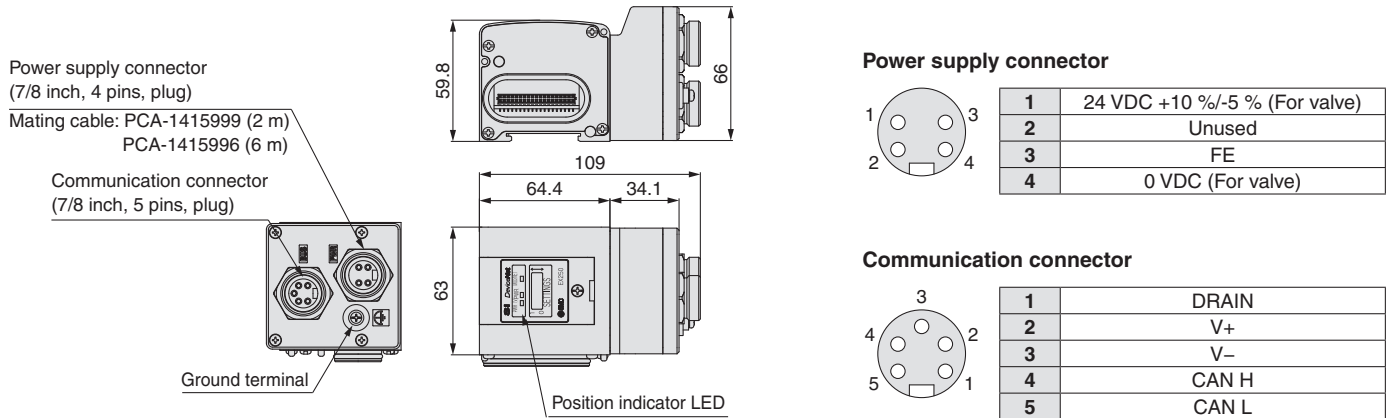

* When connecting to a VQC4000 series model, use a VVQC4000-3A-3□, etc., D side end plate. The VVQC4000-3A-2□ D side end plate used by the standard EX250-SDN1 model cannot be used as it will come into contact with the EX250-SDN1-X122.

Communication Cable

- ① With connector on one side (Socket)
Cable length: 10000 mm

For DeviceNet™

EX9-AC100 DN-X12

Applicable
protocol

DN	DeviceNet™
----	------------

For DeviceNet™

Dimensions

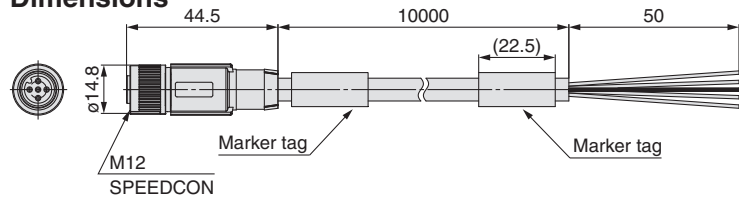

Connections

Terminal no.	Core wire colour: Signal name (DeviceNet™)
1	Shield: DRAIN
2	Red: V+
3	Black: V-
4	White: CAN H
5	Blue: CAN L

Item		Specifications
Cable O.D.		Ø 6.7 mm
Conductor nominal cross section	Power pair	0.34 mm ² /AWG22
	Data pair	0.25 mm ² /AWG24
Wire O.D. (Including insulator)	Power pair	1.4 mm
	Data pair	2.05 mm
Min. bending radius (Fixed)		67 mm

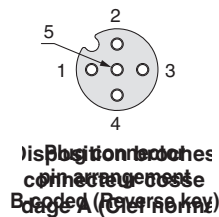

Power Supply Cable

② With connector on one side (Socket)

Cable length: 10000 mm

For PROFIBUS DP

For EtherNet/IP™

Straight connector type

EX500-AP100-S-X1

Connector specification

S Straight

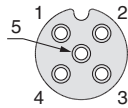
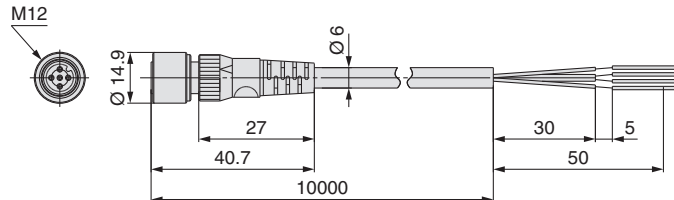

Socket connector pin arrangement
A-coded

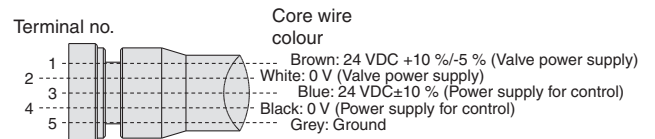

Connections (PROFIBUS DP, EtherNet/IP™)

Item	Specifications
Cable O.D.	Ø 6 mm
Conductor nominal cross section	0.3 mm ² /AWG22
Wire O.D. (Including insulator)	1.5 mm
Min. bending radius (Fixed)	40 mm



EX250 Series Specific Product Precautions

Be sure to read this before handling the products. Refer to the back cover for safety instructions. For temperature control equipment precautions, refer to the “Handling Precautions for SMC Products” and the “Operation Manual” on the SMC website: <https://www.smc.eu>

When one AS-Interface power supply system is used

⚠ Caution

	EX250-SAS7	EX250-SAS9	
Power supply voltage	Supplied from AS-Interface circuit, 26.5 to 31.6 VDC*1		
Internal current consumption	Max. 100 mA	Max. 65 mA	
Input/output specification	Number of inputs	8	
	Number of outputs	8	
	Supply voltage	24 VDC	
	Supply current*2	Max. 240 mA	Max. 120 mA

*1 For communication power supply, use a power supply dedicated to AS-Interface. For details, please refer to operation manuals provided by the respective manufacturers.

*2 The AS-Interface circuit provides current to the internal parts of the SI unit and all connected equipment. Since there is a limit on the possible supply current to all connected equipment, select the equipment connected to the input/output device to stay within the possible supply current.

Example) When EX250-SAS9 is used

Valve: VQC1100NY – 5 (low-wattage type of 0.5 W) x 4 pcs.
 $0.5 \text{ [W]} \div 24 \text{ [V]} \times 4 \text{ [pcs.]}$
 $= 84 \text{ [mA]} \text{ (4 outputs simultaneously ON)}$

The maximum possible supply current of EX250-SAS9 is 120 mA. Therefore, the possible supply current to the sensor is
 $120 \text{ [mA]} - 84 \text{ [mA]} = 36 \text{ [mA]}$

Use of low-wattage type valves by minimizing the maximum number of simultaneous outputs, and low current consumption sensors (2-wire sensor, etc.) is recommended.

Maximum number of AS-Interface compatible input blocks

SI unit specifications		Input block type		Input block maximum stations
EX250-SAS3	AS-Interface 8in/8out 31 Slave Mode, 2 power supply systems	1	M12/2 inputs	4 stations
		2	M12/4 inputs	2 stations
		3	M8/4 inputs	2 stations
EX250-SAS5	AS-Interface 4in/4out 31 Slave Mode, 2 power supply systems	1	M12/2 inputs	2 stations
		2	M12/4 inputs	1 station
		3	M8/4 inputs	1 station
EX250-SAS7	AS-Interface 8in/8out 31 Slave Mode, 1 power supply system	1	M12/2 inputs	4 stations
		2	M12/4 inputs	2 stations
		3	M8/4 inputs	2 stations
EX250-SAS9	AS-Interface 4in/4out 31 Slave Mode, 1 power supply system	1	M12/2 inputs	2 stations
		2	M12/4 inputs	1 station
		3	M8/4 inputs	1 station

Operating Environment

⚠ Caution

1. Select the proper type of enclosure according to the environment of operation.



IP65 is achieved when the following conditions are met.

- 1) Provide appropriate wiring between all units using electrical wiring cables, communication connectors and cables with M12 connectors.
- 2) Suitable mounting of each unit and valve manifold.
- 3) Be sure to mount a seal cap on any unused connectors.

If using in an environment that is exposed to water splashes, please take measures such as using a cover.

Safety Instructions

These safety instructions are intended to prevent hazardous situations and/or equipment damage. These instructions indicate the level of potential hazard with the labels of “Caution,” “Warning” or “Danger.” They are all important notes for safety and must be followed in addition to International Standards (ISO/IEC)¹⁾, and other safety regulations.

	Caution: Caution indicates a hazard with a low level of risk which, if not avoided, could result in minor or moderate injury.
	Warning: Warning indicates a hazard with a medium level of risk which, if not avoided, could result in death or serious injury.
	Danger: Danger indicates a hazard with a high level of risk which, if not avoided, will result in death or serious injury.

- 1) ISO 4414: Pneumatic fluid power – General rules relating to systems.
ISO 4413: Hydraulic fluid power – General rules relating to systems.
IEC 60204-1: Safety of machinery – Electrical equipment of machines.
(Part 1: General requirements)
ISO 10218-1: Manipulating industrial robots - Safety.
etc.

Warning

1. The compatibility of the product is the responsibility of the person who designs the equipment or decides its specifications.

Since the product specified here is used under various operating conditions, its compatibility with specific equipment must be decided by the person who designs the equipment or decides its specifications based on necessary analysis and test results. The expected performance and safety assurance of the equipment will be the responsibility of the person who has determined its compatibility with the product. This person should also continuously review all specifications of the product referring to its latest catalogue information, with a view to giving due consideration to any possibility of equipment failure when configuring the equipment.

2. Only personnel with appropriate training should operate machinery and equipment.

The product specified here may become unsafe if handled incorrectly. The assembly, operation and maintenance of machines or equipment including our products must be performed by an operator who is appropriately trained and experienced.

3. Do not service or attempt to remove product and machinery/equipment until safety is confirmed.

1. The inspection and maintenance of machinery/equipment should only be performed after measures to prevent falling or runaway of the driven objects have been confirmed.
2. When the product is to be removed, confirm that the safety measures as mentioned above are implemented and the power from any appropriate source is cut, and read and understand the specific product precautions of all relevant products carefully.
3. Before machinery/equipment is restarted, take measures to prevent unexpected operation and malfunction.

4. Contact SMC beforehand and take special consideration of safety measures if the product is to be used in any of the following conditions.

1. Conditions and environments outside of the given specifications, or use outdoors or in a place exposed to direct sunlight.
2. Installation on equipment in conjunction with atomic energy, railways, air navigation, space, shipping, vehicles, military, medical treatment, combustion and recreation, or equipment in contact with food and beverages, emergency stop circuits, clutch and brake circuits in press applications, safety equipment or other applications unsuitable for the standard specifications described in the product catalogue.
3. An application which could have negative effects on people, property, or animals requiring special safety analysis.
4. Use in an interlock circuit, which requires the provision of double interlock for possible failure by using a mechanical protective function, and periodical checks to confirm proper operation.

Caution

1. The product is provided for use in manufacturing industries.

The product herein described is basically provided for peaceful use in manufacturing industries.
If considering using the product in other industries, consult SMC beforehand and exchange specifications or a contract if necessary.
If anything is unclear, contact your nearest sales branch.

Limited warranty and Disclaimer/Compliance Requirements

The product used is subject to the following “Limited warranty and Disclaimer” and “Compliance Requirements”. Read and accept them before using the product.

Limited warranty and Disclaimer

1. The warranty period of the product is 1 year in service or 1.5 years after the product is delivered, whichever is first.²⁾ Also, the product may have specified durability, running distance or replacement parts. Please consult your nearest sales branch.
 2. For any failure or damage reported within the warranty period which is clearly our responsibility, a replacement product or necessary parts will be provided. This limited warranty applies only to our product independently, and not to any other damage incurred due to the failure of the product.
 3. Prior to using SMC products, please read and understand the warranty terms and disclaimers noted in the specified catalogue for the particular products.
- 2) Vacuum pads are excluded from this 1 year warranty.
A vacuum pad is a consumable part, so it is warranted for a year after it is delivered. Also, even within the warranty period, the wear of a product due to the use of the vacuum pad or failure due to the deterioration of rubber material are not covered by the limited warranty.

Compliance Requirements

1. The use of SMC products with production equipment for the manufacture of weapons of mass destruction (WMD) or any other weapon is strictly prohibited.
2. The exports of SMC products or technology from one country to another are governed by the relevant security laws and regulations of the countries involved in the transaction. Prior to the shipment of a SMC product to another country, assure that all local rules governing that export are known and followed.

Caution

SMC products are not intended for use as instruments for legal metrology.

Measurement instruments that SMC manufactures or sells have not been qualified by type approval tests relevant to the metrology (measurement) laws of each country.
Therefore, SMC products cannot be used for business or certification ordained by the metrology (measurement) laws of each country.

Safety Instructions

Be sure to read “Handling Precautions for SMC Products” (M-E03-3) before using.

SMC Corporation (Europe)

Austria	+43 (0)2262622800	www.smc.at	office@smc.at
Belgium	+32 (0)33551464	www.smc.be	info@smc.be
Bulgaria	+359 (0)2807670	www.smc.bg	office@smc.bg
Croatia	+385 (0)13707288	www.smc.hr	office@smc.hr
Czech Republic	+420 541424611	www.smc.cz	office@smc.cz
Denmark	+45 70252900	www.smc.dk.com	smc@smc.dk.com
Estonia	+372 6510370	www.smc.pneumatics.ee	info@smc.ee
Finland	+358 207513513	www.smc.fi	smc.fi@smc.fi
France	+33 (0)164761000	www.smc-france.fr	info@smc-france.fr
Germany	+49 (0)61034020	www.smc.de	info@smc.de
Greece	+30 210 2717265	www.smchellas.gr	sales@smchellas.gr
Hungary	+36 23513000	www.smc.hu	office@smc.hu
Ireland	+353 (0)14039000	www.smcautomation.ie	sales@smcautomation.ie
Italy	+39 03990691	www.smcitalia.it	mailbox@smcitalia.it
Latvia	+371 67817700	www.smc.lv	info@smc.lv

Lithuania	+370 5 2308118	www.smclt.lt	info@smclt.lt
Netherlands	+31 (0)205318888	www.smc.nl	info@smc.nl
Norway	+47 67129020	www.smc-norge.no	post@smc-norge.no
Poland	+48 222119600	www.smc.pl	office@smc.pl
Portugal	+351 214724500	www.smc.eu	apoioclientept@smc.smces.es
Romania	+40 213205111	www.smcromania.ro	smcromania@smcromania.ro
Russia	+7 8123036600	www.smc.eu	sales@smcru.com
Slovakia	+421 (0)413213212	www.smc.sk	office@smc.sk
Slovenia	+386 (0)73885412	www.smc.si	office@smc.si
Spain	+34 945184100	www.smc.eu	post@smc.smces.es
Sweden	+46 (0)86031200	www.smc.nu	smc@smc.nu
Switzerland	+41 (0)523963131	www.smc.ch	helpcenter@smc.ch
Turkey	+90 212 489 0 440	www.smc.pnomatik.com.tr	info@smc.pnomatik.com.tr
UK	+44 (0)845 121 5122	www.smc.uk	sales@smc.uk