

Magnetically Coupled Rodless Cylinder Slider Type/Slide Bearing

Ø 6, Ø 10, Ø 15, Ø 20, Ø 25, Ø 32, Ø 40

New

RoHS

Max. piston speed **800 mm/s**

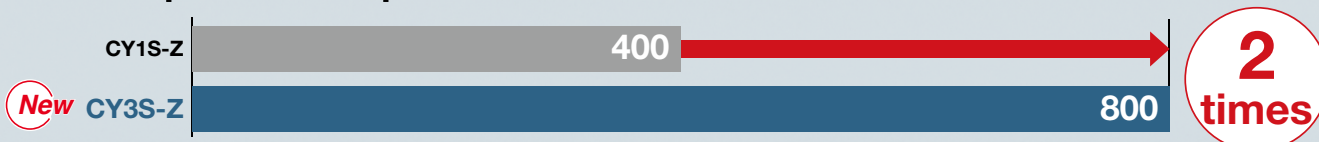

* Only when using a shock absorber * When using a rubber bumper, the max. piston speed is 400 mm/s, the same as that of the CY1S-Z.

Faster operation than the existing product is achieved by increasing the max. piston speed to 800 mm/s.

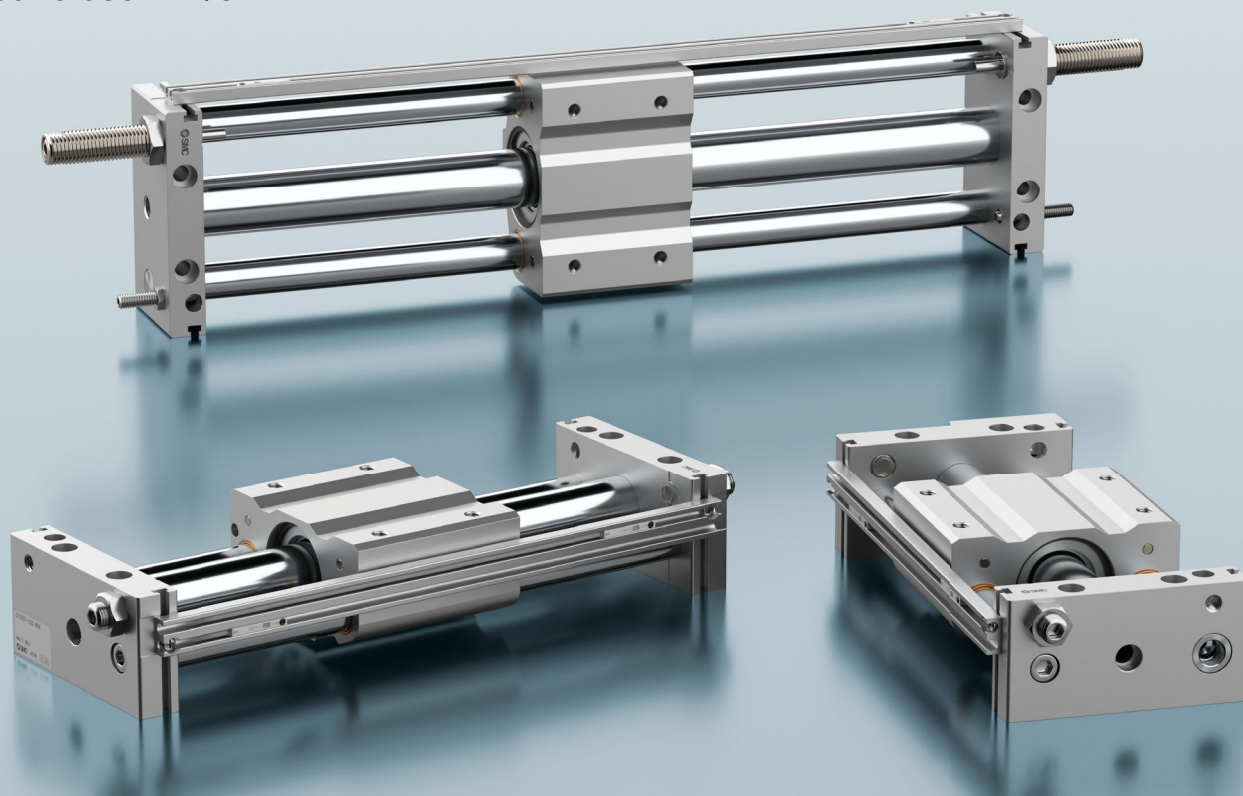

■ Mounting dimensions are compatible with the existing CY1S-Z series products.

Series Variations

Type	Bore size	Standard stroke [mm]	Piston speed	Cushion	Piping port	Stopper type
	6	50 to 200	50 to 800 mm/s	Rubber bumper Shock absorber	M3 x 0.5	Bumper bolt Shock absorber/ Adjustment bolt
	10	50 to 300			M5 x 0.8	
	15	50 to 500			M5 x 0.8	
	20	100 to 800			(Rc, NPT, G)1/8	
	25	100 to 800			(Rc, NPT, G)1/8	
	32	100 to 800			(Rc, NPT, G)1/8	
	40	100 to 1000			(Rc, NPT, G)1/4	

CY3S Series



CAT.EUS20-327A-UK

Stable operation

Smooth operation is achieved by extending the length of the slide block side wear ring by max. 30 %.

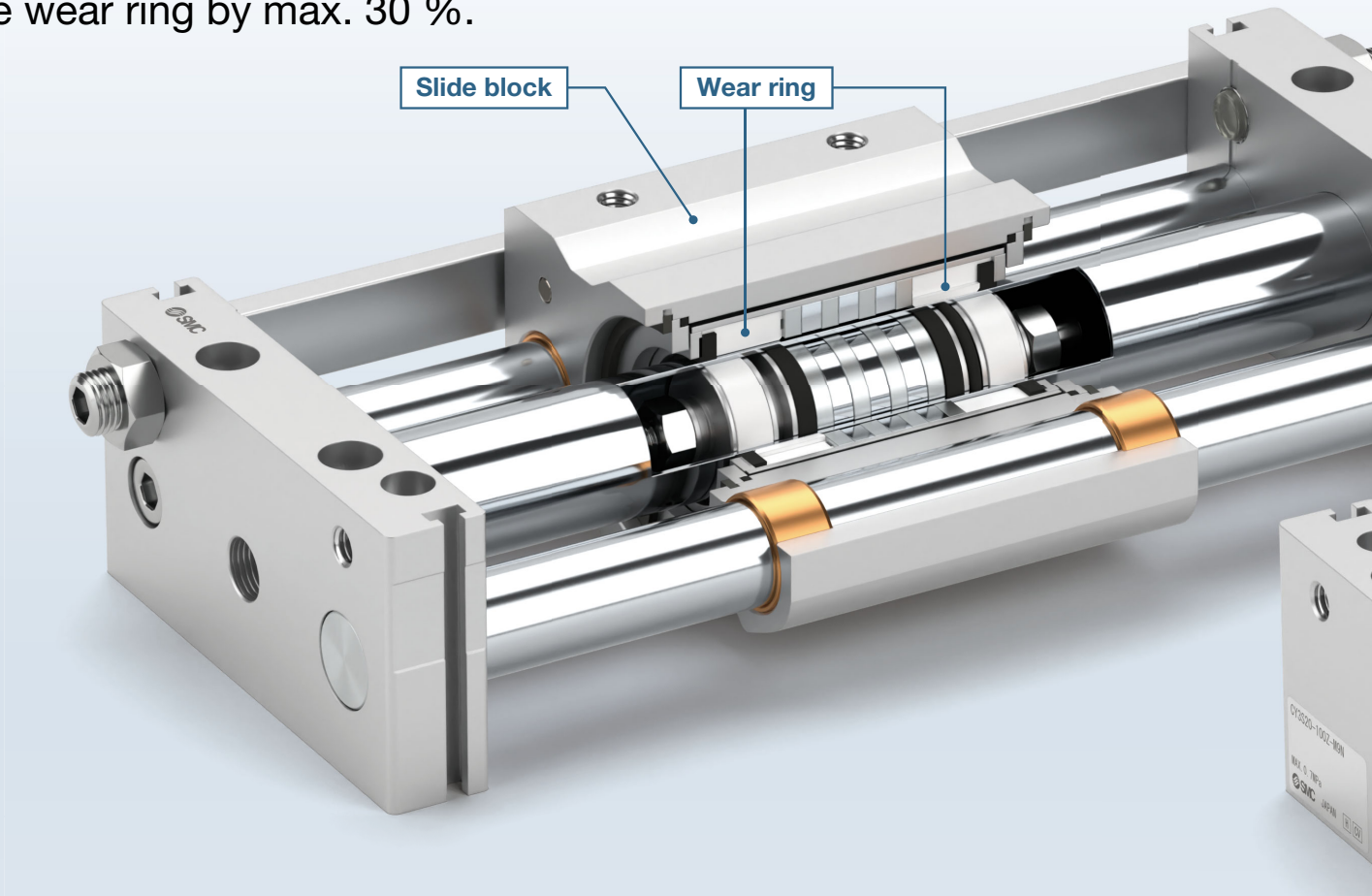

- The specifications, magnet holding force, and mounting dimensions are the same as those of the existing CY1S-Z series model.

Bilateral piping and centralised piping versions available

- Bilateral piping type

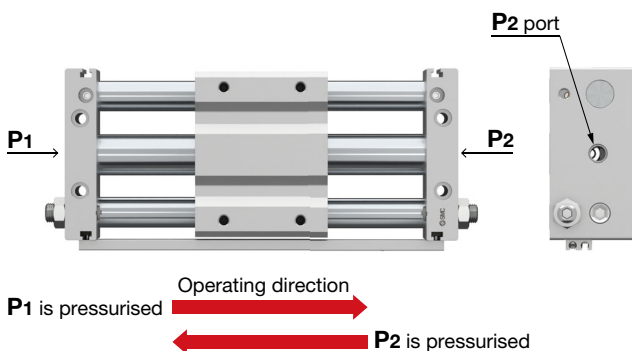

- Centralised piping type

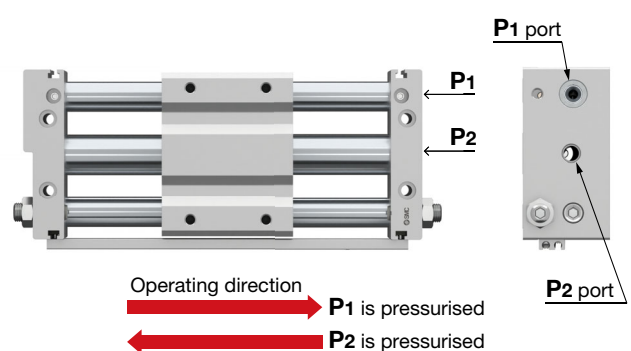

Shock absorber

The RJ series soft stop shock absorbers fitted as standard

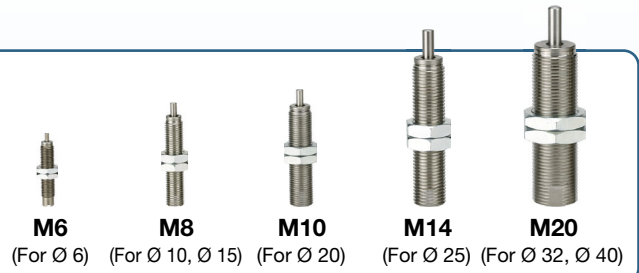

■ Available with or without auto switch rails as standard



Capable to mount the auto switches in parallel

Two auto switch mounting slots aligned in parallel allow auto switches to mount directly to the rail, and make it easier to house the auto switch wiring in the rail.

Improved auto switch mounting

Small auto switches can be mounted directly. D-M9□/D-A9□



3 options available for stroke adjustment

- Bumper bolt (resin tipped)

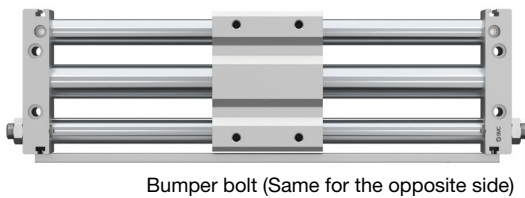

- Shock absorber + Adjustment bolt (metal ended)

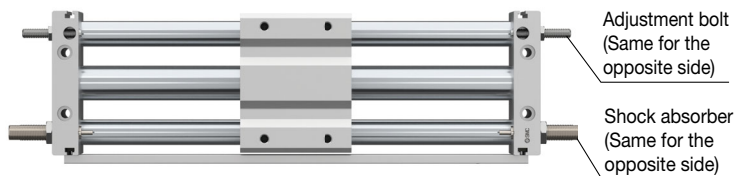

- Shock absorber + Adjustment bolt (metal ended) on one side
- Bumper bolt (resin tipped) on one side

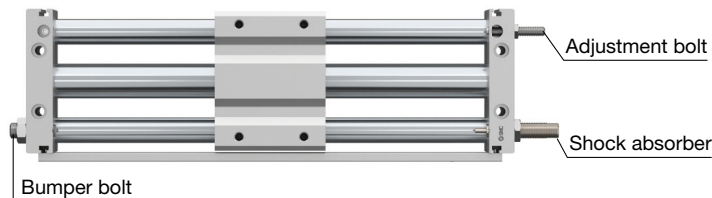

Magnetically Coupled Rodless Cylinder Slider Type/Slide Bearing *CY3S Series*

Series Variations

Bore size	Standard stroke [mm]															Piston speed	Cushion	Mounting orientation	Magnetic holding force
	50	100	150	200	250	300	350	400	450	500	600	700	800	900	1000				
6	●	●	●	●												50 to 800*1 mm/s	Rubber bumper Shock absorber	Horizontal Inclined Vertical	19.6 N
10	●	●	●	●	●	●													53.9 N
15	●	●	●	●	●	●	●	●	●	●									137 N
20		●	●	●	●	●	●	●	●	●	●	●	●	●					231 N
25		●	●	●	●	●	●	●	●	●	●	●	●	●	●				363 N
32		●	●	●	●	●	●	●	●	●	●	●	●	●	●				588 N
40		●	●	●	●	●	●	●	●	●	●	●	●	●	●				922 N

*1 50 to 400 mm/s when using a rubber bumper

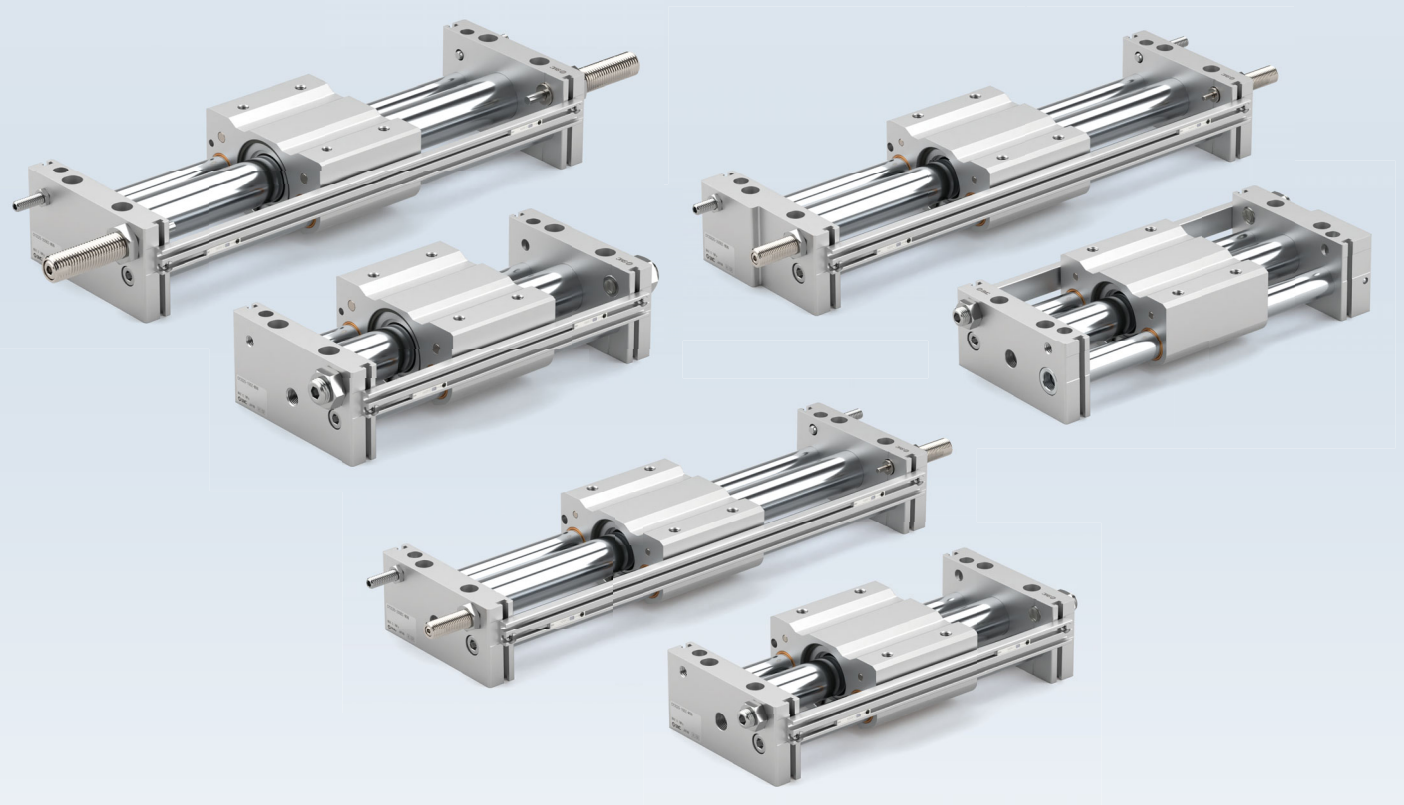

CONTENTS

Related Products	p. 4
Model Selection	p. 5
How to Order	p. 17
Specifications	p. 18
Construction	p. 19
Dimensions	p. 21
Auto Switch Mounting	p. 23
Specific Product Precautions	p. 24



Related Products

Deceleration Controller DAS Series

2-speed control reduces cycle time
Allows for the impact relaxation of the stroke end

Allows for the 2-speed control of cylinders

The deceleration position (cushion timing) and

2nd speed (cushion intensity)

can be adjusted.

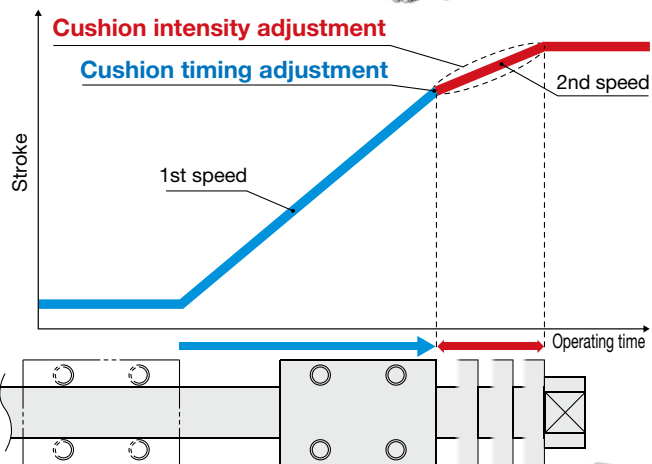

Piping Example

For double-end

Deceleration after high-speed driving

Deceleration Controller

L side Deceleration position adjustment

L side 2nd speed adjustment

R side Deceleration position adjustment

R side 2nd speed adjustment

Valve

Air for adjusting the deceleration force position is supplied by drive air

Deceleration position adjustment (Light blue) (Timing knob)

2nd speed adjustment (Grey) (2nd speed knob)

For single-end

Deceleration after high-speed driving

Deceleration Controller

L side Deceleration position adjustment

L side 2nd speed adjustment

Valve

Air for adjusting the deceleration force position is supplied by drive air

Deceleration position adjustment (Light blue) (Timing knob)

2nd speed adjustment (Grey) (2nd speed knob)

Variations

Mounting	Body size	Applicable tubing O.D.										Bore size
		Metric size					Inch size					
		4	6	8	10	12	5/32"	1/4"	5/16"	3/8"	1/2"	
	5	•	•	•			•	•	•			Ø 10 to Ø 40
	7			•	•	•			•	•	•	Up to Ø 100

CY3S Series Model Selection

Selection Flow Chart

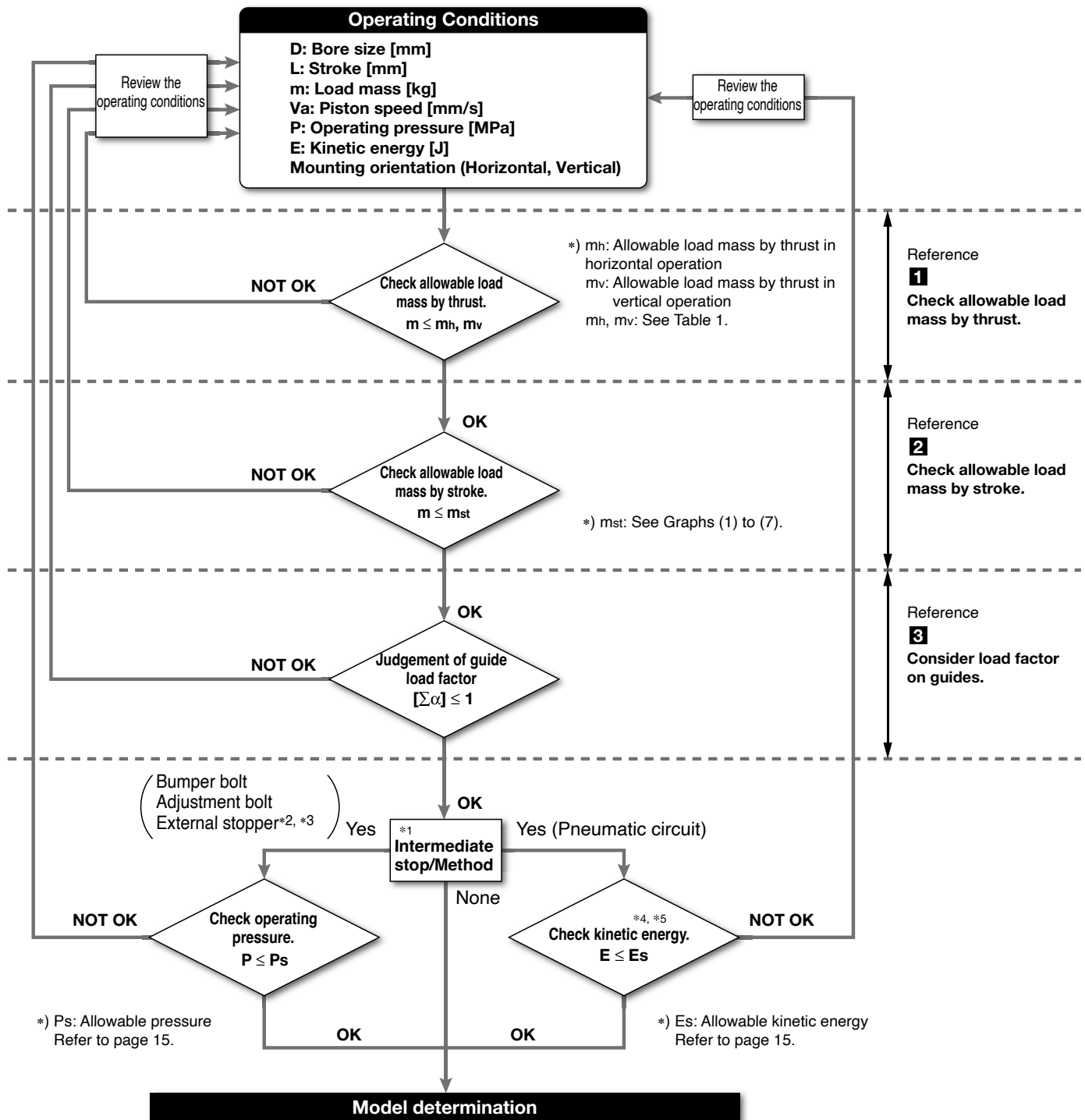

*1 Stroke adjustment with either a bumper bolt or adjustment bolt is considered as an intermediate stop.

*2 When an intermediate stop is performed with an external stopper, consider the dynamic load as shown below.

• Bumper bolt: $\delta = 4/100$

• Shock absorber and air cushion: $\delta = 1/100$

In addition to this, check the judgement results of the guide load factor. (δ : Bumper coefficient)

*3 When an external stopper is used in conjunction with a shock absorber, check the model selection of shock absorber separately.

*4 This cylinder cannot perform an intermediate stop with the pneumatic circuit in vertical operation.

The intermediate stop is only performed with a bumper bolt, adjustment bolt or external stopper.

*5 When an intermediate stop is performed with the pneumatic circuit, the stopping accuracy may vary significantly.

If accuracy is required, be sure to perform the intermediate stop with a bumper bolt, adjustment bolt or external stopper.

1 Check allowable load mass by thrust.

In this series, the work load and the maximum operating pressure are restricted to prevent the magnetic coupling from being separated. Ensure that the work load mass and operating pressure are within the values in Table 1.

Table 1. Allowable load mass by thrust and maximum operating pressure

Bore size [mm]	Horizontal operation m_h [kg]	Horizontal operation Max. operating pressure P_h [MPa]*1	Vertical operation m_v [kg]	Vertical operation Max. operating pressure P_v [MPa]
6	1.8	0.70	1.0	0.55
10	3.0		2.7	
15	7.0		7.0	
20	12		11	0.65
25	20		18.5	
32	30		30	
40	50	47		

*1 Without stroke adjustment

When stroke adjustment is performed with bumper bolt, adjustment bolt, or intermediate stop is performed with an external stopper, the maximum operating pressure should be as shown on page 15.

2 Check allowable load mass by stroke.

In this series, guide shafts are assembled to support the load.

Deflection of the guide shaft increases due to work load mass and rolling moment (M_2), so the work load mass and stroke is restricted. Check that the load mass is within the allowable load mass by stroke: m_{st} from Graphs (1) to (7) for each bore size.

[Horizontal mounting and Ceiling mounting]

The allowable load mass by stroke range varies depending on the y direction of the loads centre of gravity.

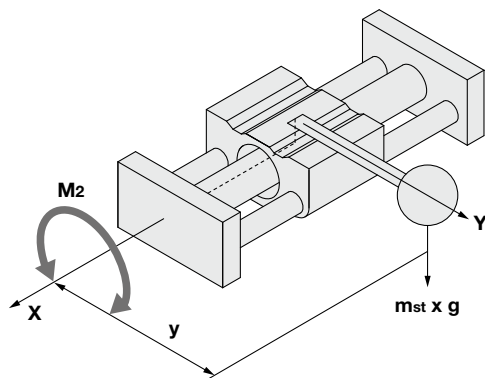

[Wall mounting]

The allowable load mass by stroke range varies depending on the z direction of the loads centre of gravity.

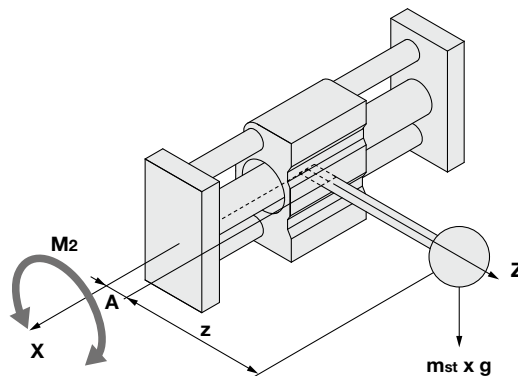

[Vertical mounting]

Load mass is not restricted by stroke.

A: Distance between the centre of the guide shaft and the upper surface of the slide block

2 Check allowable load mass by stroke.

Selection Graph

[Graph 1] Allowable load mass by stroke $\varnothing 6$

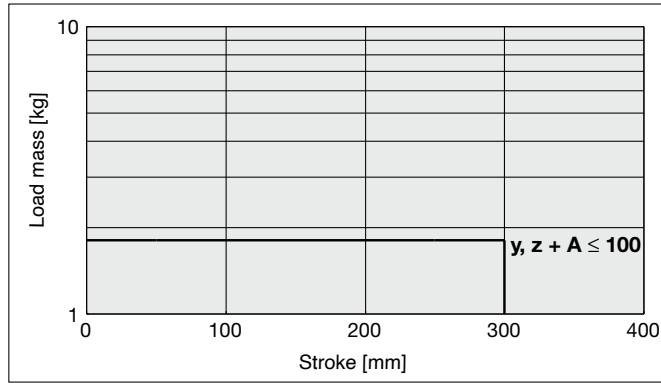

[Graph 2] Allowable load mass by stroke $\varnothing 10$

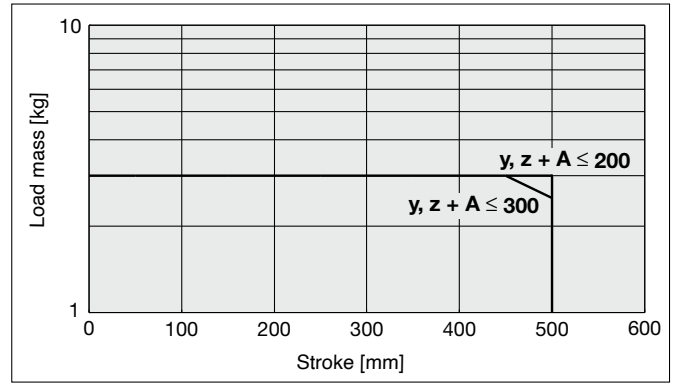

[Graph 3] Allowable load mass by stroke $\varnothing 15$

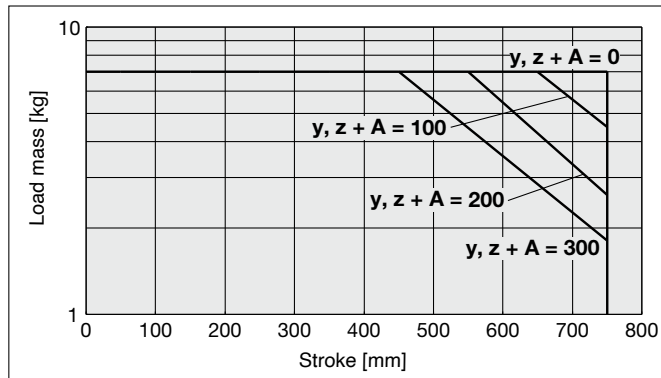

[Graph 4] Allowable load mass by stroke $\varnothing 20$

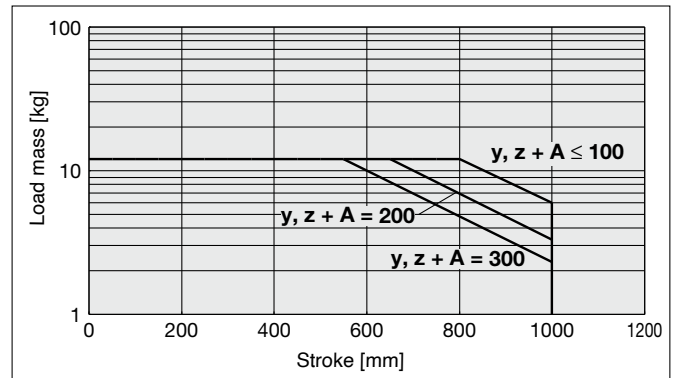

[Graph 5] Allowable load mass by stroke $\varnothing 25$

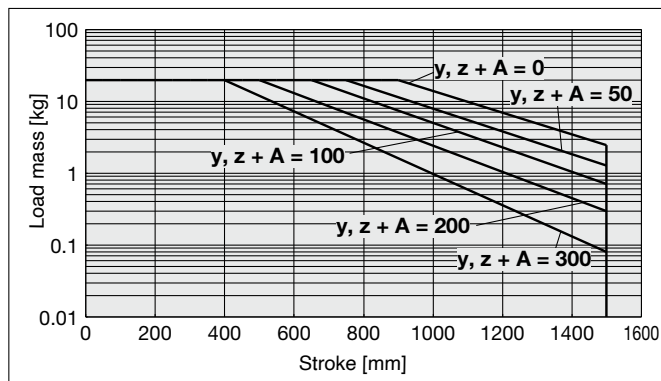

[Graph 6] Allowable load mass by stroke $\varnothing 32$

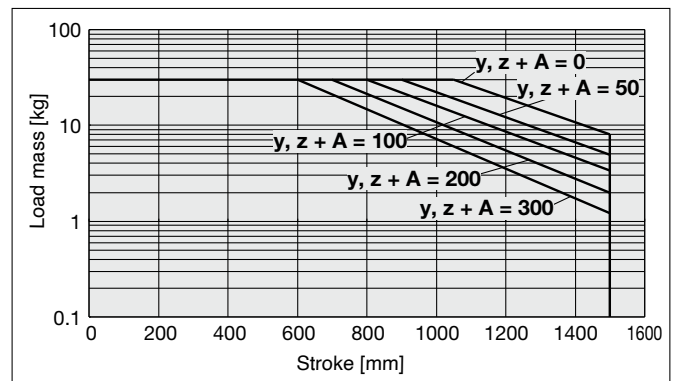

[Graph 7] Allowable load mass by stroke $\varnothing 40$

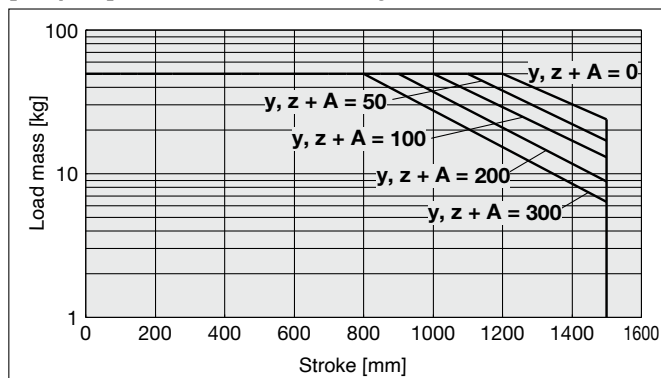

* If the load centre of gravity exceeds the value of $y, z + A$ on the graph, install an external guide on the cylinder separately to make sure it is within the allowable range.

3 Consider load factor on guides.

3-① Types of moment applied to rodless cylinders

Multiple moments may be generated depending on the mounting orientation, load, and position of the centre of gravity.

Coordinates and Moments

* The direction of the axis, X, Y and Z are based on the cylinder mounting orientation shown on the right. Consider the direction of the axis for each mounting direction.

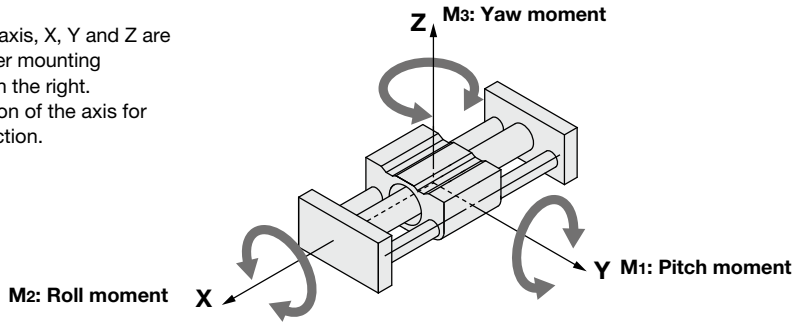

Static moment calculation by mounting type

[Horizontal mounting]

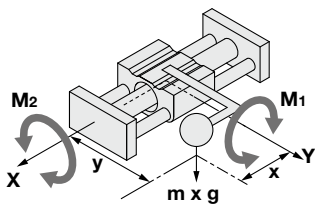

[Ceiling mounting]

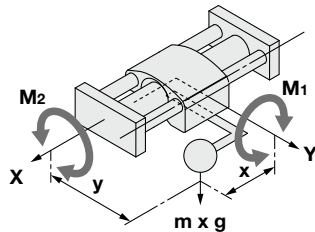

[Wall mounting]

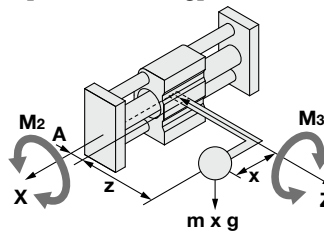

[Vertical mounting]

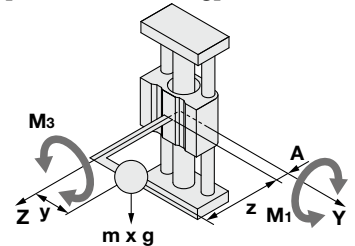

Table 2. Mounting orientation and static moment

Mounting orientation	Horizontal mounting	Ceiling mounting	Wall mounting	Vertical mounting	
Static load	m				
Static moment	M1	$m \times g \times x$	$m \times g \times x$	—	$m \times g \times (z + A)$
	M2	$m \times g \times y$	$m \times g \times y$	$m \times g \times (z + A)$	—
	M3	—	—	$m \times g \times x$	$m \times g \times y$

Bore size [mm]	A [mm]
6	19
10	21
15	25
20	27
25	33
32	40
40	49

* A: Distance between the centre of the guide shaft and the upper surface of the slide block (See the table on the right.)

Dynamic moment calculation by mounting type

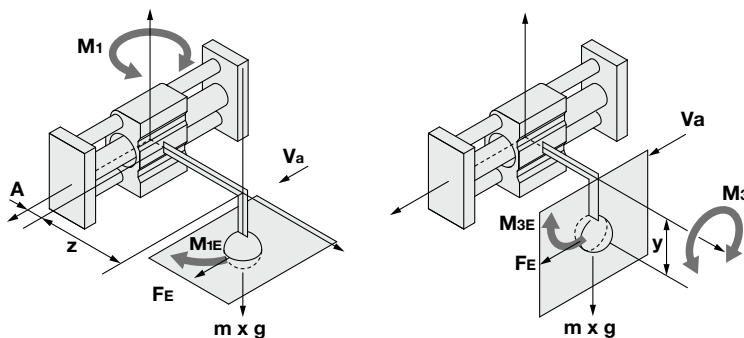

Table 3. Mounting orientation and dynamic moment

Mounting orientation	Horizontal mounting	Ceiling mounting	Wall mounting	Vertical mounting
Dynamic load FE	$\delta \times 1.4 \times Va \times m \times g$		Bumper bolt: $\delta = 4/100$ Shock absorber: $\delta = 1/100$	
Dynamic moment	M1E	$1/3 \times FE \times (z + A)$		
	M2E	Dynamic moment does not occur.		
	M3E	$1/3 \times FE \times y$		

Regardless of the mounting orientation, dynamic moment is calculated with the formulas above.

CY3S Series

3 Consider load factor on guides.

3-② Allowable load mass on guides/Allowable moment

Table 4. Allowable load mass on guides and moment

Bore size [mm]	Allowable load mass on guides m [kg]	Allowable moment [N·m]		
		M1	M2	M3
6	9	1.3	1.4	1.3
10	15	2.6	2.9	2.6
15	35	8.6	8.9	8.6
20	60	17	18	17
25	104	30	35	30
32	195	67	82	67
40	244	96	124	96

The table above indicates the maximum performance of the guide, but does not show the actual allowable work load mass. Refer to Graphs (8) to (10) for correct allowable mass by piston speed.

[Graph 8] Allowable load mass on guides **m**

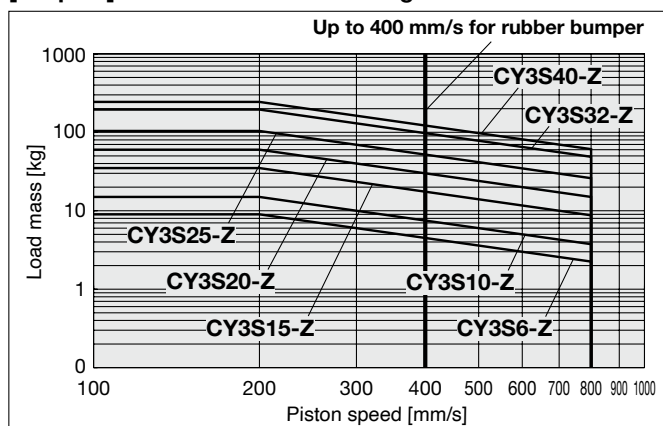

[Graph 9] Allowable moment **M1, M3**

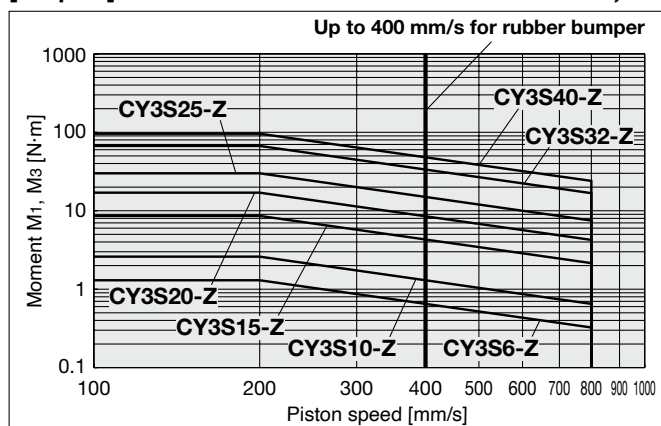

[Graph 10] Allowable moment **M2**

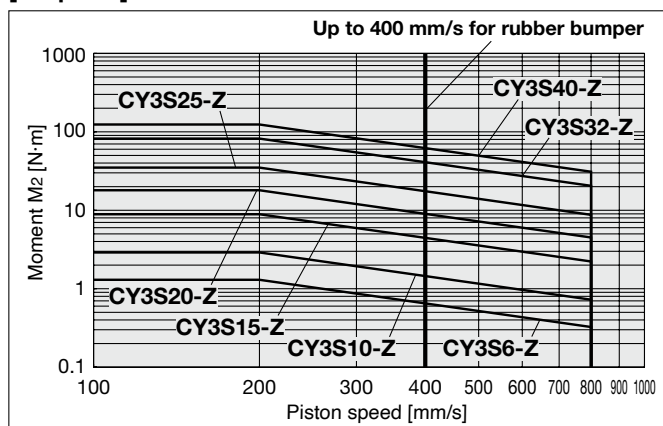

3-③ Consideration of guide load factor

Work load mass and allowable moment varies depending on the load mounting method, stroke, cylinder mounting orientation and piston speed.

Whether the cylinder is suitable or not is decided by the allowable load mass on guides in the graphs.

The selection calculation is shown below.

It is necessary to consider i) allowable load mass on guides, ii) static moment and iii) dynamic moment (when the slide block collides with the stopper).

- * i) - ii) is calculated with Va (average speed) and iii) is calculated with V (collision speed $V = 1.4Va$).
- Calculate m_{max} of i) from the allowable load mass on guides in Graph (8), and calculate M_{max} of ii) and iii) from the allowable moment (M_1, M_2, M_3) in Graphs (9) and (10).

Sum of guide load factors $\Sigma\alpha = \frac{\text{Load mass (m)}}{\text{Allowable load mass on guides (m}_{max})} + \frac{\text{Static moment (M)}^{*1}}{\text{Allowable static moment (M}_{max})} + \frac{\text{Dynamic moment (ME)}^{*2}}{\text{Allowable dynamic moment (ME}_{max})} \leq 1$

- *1 Moment caused by the load etc., with cylinder in resting condition
- *2 Moment caused by the load equivalent to impact at the stroke end (at the time of impact with stopper)
- * Several moments might be generated depending on the cylinder mounting orientation or the load centre of gravity, so the sum of the allowable load mass on guides, allowable static moment and allowable dynamic moment will be the sum of all these guide load factors.

Calculation method to determine the centre of gravity when several loads are mounted on the cylinder

When several loads are mounted on the cylinder, it is difficult to calculate the centre of gravity. As shown in the figure below, the centre of gravity of the load is calculated from the total load mass and of centre of gravity for all the loads.

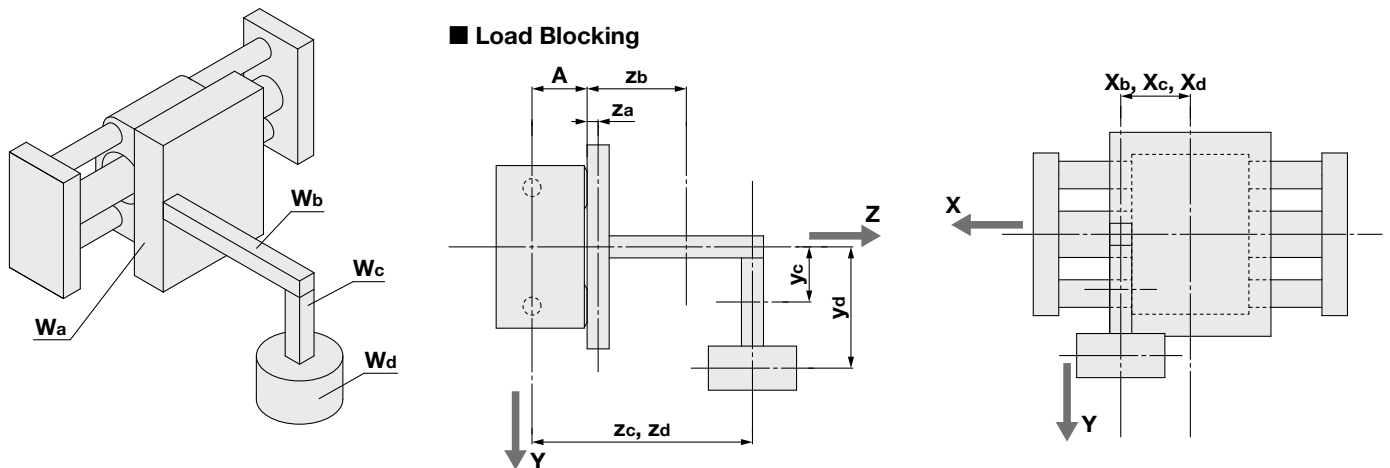

Mass and centre of gravity of the load

Load no. W_n	Mass m_n	Centre of gravity		
		X-axis x_n	Y-axis y_n	Z-axis z_n
Wa	m_a	x_a	y_a	z_a
Wb	m_b	x_b	y_b	z_b
Wc	m_c	x_c	y_c	z_c
Wd	m_d	x_d	y_d	z_d

Calculation for Overall Centre of Gravity

$$m_t = \Sigma m_n \dots \textcircled{1}$$

$$X = \frac{1}{m_t} \times \Sigma (m_n \times x_n) \dots \textcircled{2}$$

$$Y = \frac{1}{m_t} \times \Sigma (m_n \times y_n) \dots \textcircled{3}$$

$$Z = \frac{1}{m_t} \times \Sigma \{m_n \times (A + z_n)\} \dots \textcircled{4}$$

$(n = a, b, c, d)$

Refer to the following sections ① to ④ to calculate the centre of gravity and the total load.

Refer to page 11 for detailed selection procedure.

Calculation of Guide Load Factor

The selection calculation finds the load factors (α_n) of the items below, where the total does not exceed 1.

Item	Load factor α_n	Note
1: Maximum load mass	$\alpha_1 = m/m_{\max}$	Examine m . m_{\max} is the max. load mass for V_a .
2: Static moment	$\alpha_2 = M/M_{\max}$	Examine M_1, M_2, M_3 . M_{\max} is the allowable moment for V_a .
3: Dynamic moment	$\alpha_3 = ME/ME_{\max}$	Examine M_{1E}, M_{3E} . ME_{\max} is the allowable moment for V .

Calculation example 1 Mounting on horizontal wall

[1] Operating Conditions

Cylinder: **CY3SG25-600Z**
 Cushion: Shock absorber
 Mounting: Horizontal wall mounting
 Speed: $V_a = 250$ [mm/s]

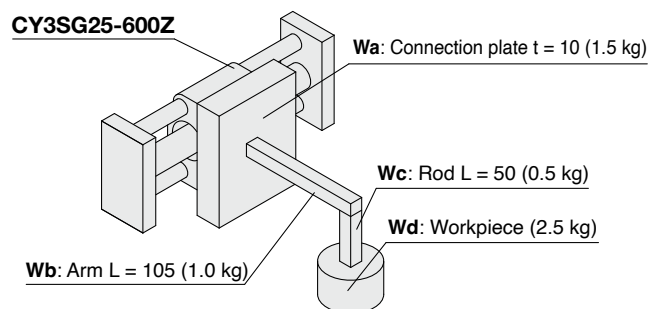

[2] Load Blocking

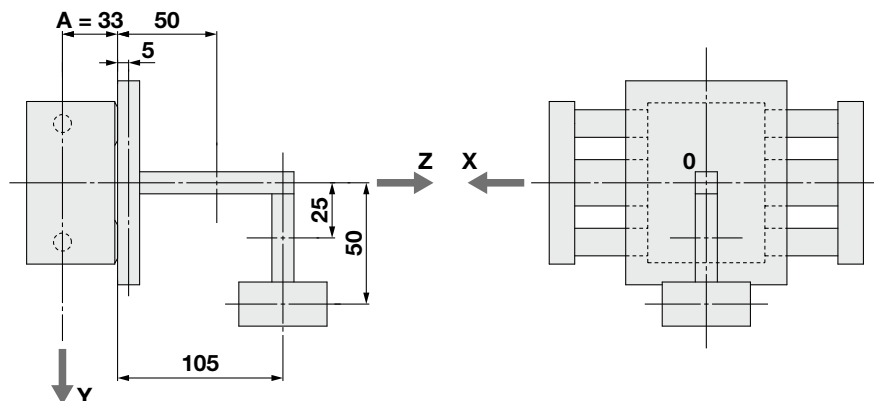

Mass and centre of gravity of the load

Load no.	Mass m_n	Centre of gravity		
		X-axis x_n	Y-axis y_n	Z-axis z_n
Wa	1.5 kg	0 mm	0 mm	5 mm
Wb	1.0 kg	0 mm	0 mm	50 mm
Wc	0.5 kg	0 mm	25 mm	105 mm
Wd	2.5 kg	0 mm	50 mm	105 mm

$n = a, b, c, d$

[3] Calculation for Overall Centre of Gravity

$$\begin{aligned}
 m_t &= \sum m_n \\
 &= 1.5 + 1.0 + 0.5 + 2.5 \\
 &= 5.5 \text{ kg}
 \end{aligned}$$

$$X = 0 \text{ mm}$$

(The centre of gravity in the x direction of all workpieces is 0, so $X = 0$ mm.)

$$\begin{aligned}
 Y &= \frac{1}{m_t} \times \sum (m_n \times y_n) \\
 &= \frac{1}{5.5} \times (1.5 \times 0 + 1.0 \times 0 + 0.5 \times 25 + 2.5 \times 50) \\
 &= 25 \text{ mm}
 \end{aligned}$$

$$\begin{aligned}
 Z &= \frac{1}{m_t} \times \sum \{m_n \times (A + z_n)\} \\
 &= \frac{1}{5.5} \times \{1.5 \times (33 + 5) + 1.0 \times (33 + 50) + 0.5 \times (33 + 105) + 2.5 \times (33 + 105)\} \\
 &= 100 \text{ mm}
 \end{aligned}$$

[4] Check the allowable load.

Item	Result	Note
(1) Check allowable load mass by thrust.	Work load is 5.5 kg < 20 kg. OK	Check allowable load by thrust. The bore size is $\varnothing 25$, so the allowable load by thrust will be 20 kg.
(2) Allowable load by stroke	Work load is 5.5 kg < 20 kg. OK	The load is restricted to 20 kg when the stroke is 600 mm and $Z = 100$ mm taken from Graph (5) 1 (Refer to page 12).

[5] Judgement of Guide Load Factor

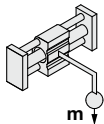
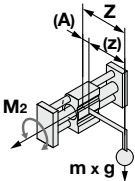
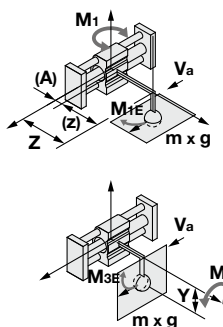
Item	Load factor α_n	Note
1 Load mass 	$\alpha_1 = m/m_{max}$ $= 5.5/83.2$ $= 0.07$	Examine m. Find the value of m_{max} when $V_a = 250$ mm/s from Graph (8) [2].
2 Static moment 	$M_2 = m \times g \times Z$ $= 5.5 \times 9.8 \times 100/1000$ $= 5.4$ [N·m] $\alpha_2 = M_2/M_{2max}$ $= 5.4/28.0$ $= 0.19$	Examine M_2 . M_1, M_3 values do not apply to this example. Refer to [3] Calculation for Overall Centre of Gravity in the Z-axis. Find the value M_{2max} when $V_a = 250$ mm/s from Graph (10) [3].
3 Dynamic moment 	$F_E = 1.4 \times V_a \times m \times g \times \delta$ $= 1.4 \times 250 \times 5.5 \times 9.8 \times 1/100$ $= 188.7$ [N] $M_{1E} = 1/3 \times F_E \times Z$ $= 1/3 \times 188.7 \times 100/1000$ $= 6.3$ [N·m] $\alpha_{3A} = M_{1E}/M_{1max}$ $= 6.3/17.1$ $= 0.37$	Calculate for the impact load. Since the impact is absorbed by shock absorber, the bumper coefficient $\delta = 1/100$ Examine M_{1E} . Calculate the collision speed V. $V = 1.4 \times V_a$ $V = 1.4 \times 250$ $V = 350$ mm/s Find the value M_{1Emax} when $V_a = 350$ mm/s from Graph (9) [4].
	$M_{3E} = 1/3 \times F_E \times Y$ $= 1/3 \times 188.7 \times 25/1000$ $= 1.6$ [N·m] $\alpha_{3B} = M_{3E}/M_{3max}$ $= 1.6/17.1$ $= 0.09$	Examine M_{3E} . Refer to [3] Calculation for Overall Centre of Gravity in the Y-axis. From the results above, Find the value M_{3Emax} when $V_a = 350$ mm/s from Graph (9) [5].
4 Judgement	$\Sigma\alpha_n = \alpha_1 + \alpha_2 + \alpha_{3A} + \alpha_{3B}$ $= 0.07 + 0.19 + 0.37 + 0.09$ $= 0.72$	$\Sigma\alpha_n = 0.72 \leq 1$, so the cylinder can be used.

[Graph 5] Allowable load mass by stroke $\varnothing 25$

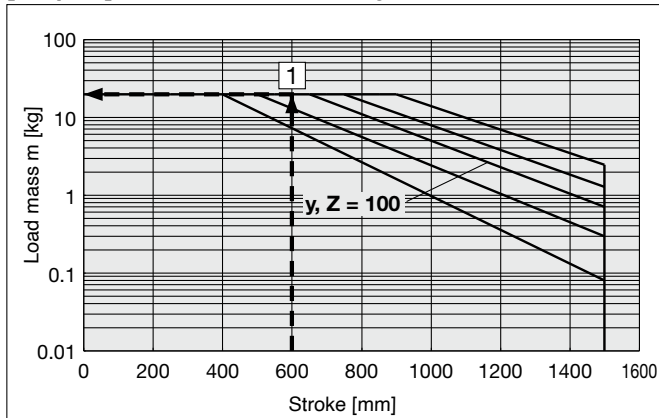

[Graph 8] Allowable load mass on guides m

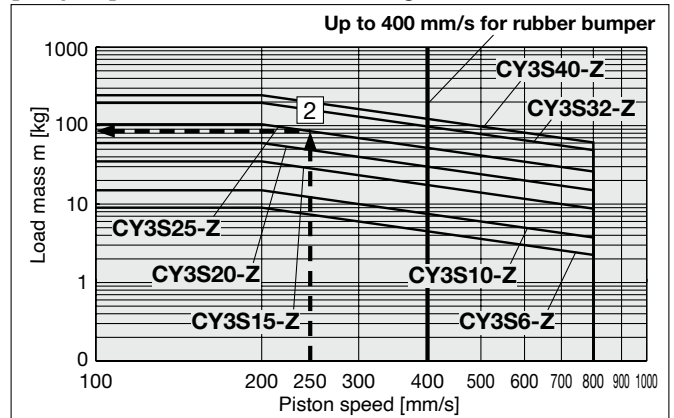

[Graph 10] Allowable moment M_2

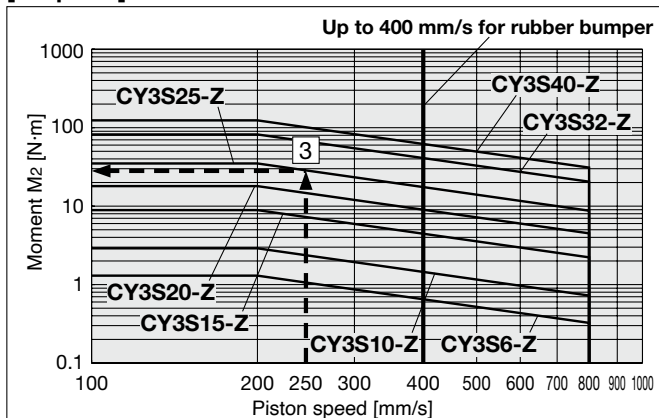

[Graph 9] Allowable moment M_1, M_3

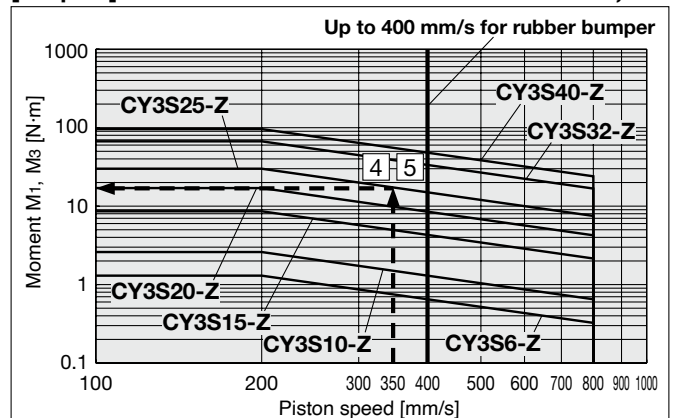

Calculation of Guide Load Factor

Calculation example 2 Vertical mounting

[1] Operating Conditions

Cylinder: **CY3SG20-700Z**
 Cushion: Shock absorber
 Mounting: Vertical mounting
 Speed: $V_a = 200$ [mm/s]

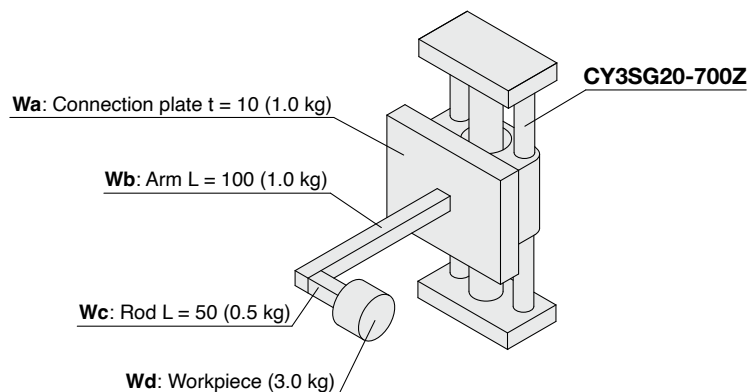

[2] Load Blocking

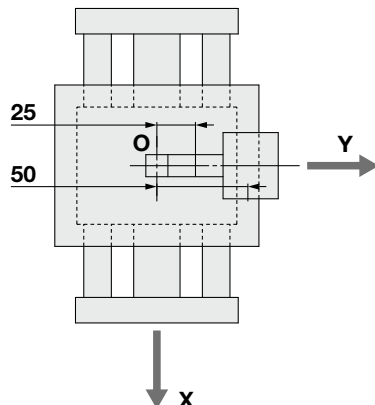
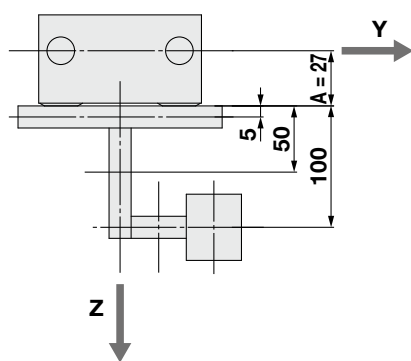

Mass and centre of gravity of the load

Load no. W_n	Mass m_n	Centre of gravity		
		X-axis x_n	Y-axis y_n	Z-axis z_n
W_a	1.0 kg	0 mm	0 mm	5 mm
W_b	1.0 kg	0 mm	0 mm	50 mm
W_c	0.5 kg	0 mm	25 mm	100 mm
W_d	3.0 kg	0 mm	50 mm	100 mm

$n = a, b, c, d$

[3] Calculation for Overall Centre of Gravity

$$m_t = \sum m_n$$

$$= 1.0 + 1.0 + 0.5 + 3.0$$

$$= 5.5 \text{ kg}$$

$$X = 0 \text{ mm}$$

(The centre of gravity in the x direction of all workpieces is 0, so $X = 0$ mm.)

$$Y = \frac{1}{m_t} \times \sum (m_n \times y_n)$$

$$= \frac{1}{5.5} \times (1.0 \times 0 + 1.0 \times 0 + 0.5 \times 25 + 3.0 \times 50)$$

$$= 30 \text{ mm}$$

$$Z = \frac{1}{m_t} \times \sum \{m_n \times (A + z_n)\}$$

$$= \frac{1}{5.5} \times \{1.0 \times (27 + 5) + 1.0 \times (27 + 50) + 0.5 \times (27 + 100) + 3.0 \times (27 + 100)\}$$

$$= 101 \text{ mm}$$

[4] Check the allowable load.

Item	Result	Note
(1) Check allowable load mass by thrust.	Work load is 5.5 kg < 11 kg. OK	Check the allowable load for vertical mounting. The bore size is $\varnothing 20$, so the maximum load for vertical mounting will be 11 kg.
(2) Allowable load by stroke	No restriction	The cylinder is mounted in the vertical direction, and the load generates no rolling moment, so there is not restriction.

[5] Judgement of Guide Load Factor

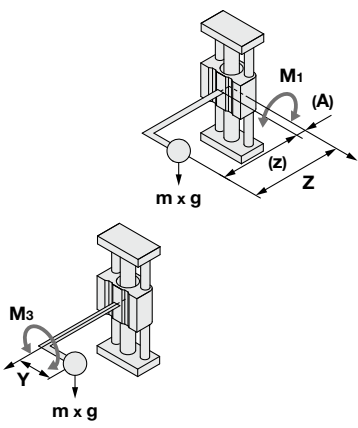
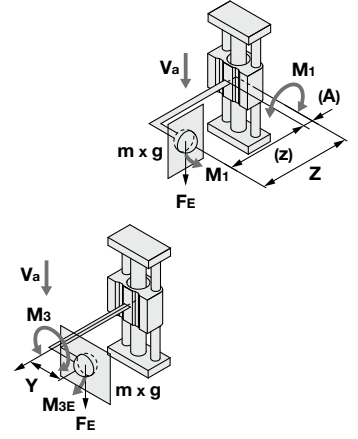
Item	Load factor α_n	Note
1 Load mass	$\alpha_1 = 0$	In case of vertical mounting, no static load is applied.
2 Static moment 	$M_1 = m \times g \times Z$ $= 5.5 \times 9.8 \times 101/1000$ $= 5.4 \text{ [N}\cdot\text{m]}$ $\alpha_{2A} = M_1/M_{1\max}$ $= 5.4/17.0$ $= 0.32$	Examine M_1 . Refer to [3] Calculation for Overall Centre of Gravity in the Z-axis. Find the value of $M_{1\max}$ when $V_a = 200 \text{ mm/s}$ from Graph (9) 1 .
	$M_3 = m \times g \times Y$ $= 5.5 \times 9.8 \times 30/1000$ $= 1.6 \text{ [N}\cdot\text{m]}$ $\alpha_{2B} = M_3/M_{3\max}$ $= 1.6/17.0$ $= 0.10$	Examine M_3 . Refer to [3] Calculation for Overall Centre of Gravity in the Y-axis. Find the value of $M_{3\max}$ when $V_a = 200 \text{ mm/s}$ from Graph (9) 2 . M_2 value does not apply to this example.
3 Dynamic moment 	$F_E = 1.4 \times V_a \times m \times g \times \delta$ $= 1.4 \times 200 \times 5.5 \times 9.8 \times 1/100$ $= 150.9 \text{ [N]}$ $M_{1E} = 1/3 \times F_E \times Z$ $= 1/3 \times 150.9 \times 101/1000$ $= 5.1 \text{ [N}\cdot\text{m]}$ $\alpha_{3A} = M_{1E}/M_{1\max}$ $= 5.1/12.1$ $= 0.42$	Calculate the impact load. Since the impact is absorbed by shock absorber, the bumper coefficient $\delta = 1/100$ Examine M_{1E} . Calculate the collision speed V . $V = 1.4 \times V_a$ $V = 1.4 \times 200$ $V = 280 \text{ mm/s}$ Find the value of $M_{1E\max}$ when $V_a = 280 \text{ mm/s}$ from Graph (9) 3 .
	$M_{3E} = 1/3 \times F_E \times Y$ $= 1/3 \times 150.9 \times 30/1000$ $= 1.5 \text{ [N}\cdot\text{m]}$ $\alpha_{3B} = M_{3E}/M_{3\max}$ $= 1.5/12.1$ $= 0.12$	Examine M_{3E} . From the results above, Find the value of $M_{3E\max}$ when $V_a = 280 \text{ mm/s}$ from Graph (9) 4 .
4 Judgement	$\Sigma\alpha_n = \alpha_1 + \alpha_{2A} + \alpha_{2B} + \alpha_{3A} + \alpha_{3B}$ $= 0 + 0.32 + 0.10 + 0.42 + 0.12$ $= 0.96$	$\Sigma\alpha_n = 0.96 \leq 1$, so the cylinder can be used.

[Graph 9] Allowable moment

M_1, M_3

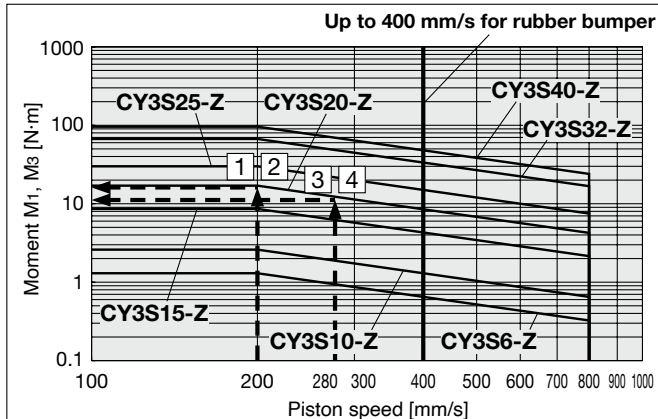

Load factors on the guides can be calculated with the SMC Pneumatic CAD system.

Caution on Design

Vertical Operation

When operating a load vertically, it should be operated within the allowable load mass and allowable pressure as shown in the table below.

Operating the cylinder above the specified values may lead to the load dropping. If accurate stopping position is required, consider using a metal-ended external stopper.

Bore size [mm]	Allowable load mass (mv) [kg]	Allowable pressure (Pv) [MPa]
6	1.0	0.55
10	2.7	
15	7.0	
20	11.0	0.65
25	18.5	
32	30.0	
40	47.0	

- * Use caution, as operating the cylinder above the allowable pressure may lead to the magnetic coupling separating and allowing the load to fall.
- * The allowable load mass above indicates the allowable load mass in the vertical operation. The actual load mass must be determined by referring to the model selection flow chart.
- * As a guide, the load mass should be approximately 60 % of the thrust load factor.

Intermediate Stop

1. When an intermediate stop is performed with an external stopper etc.

When stopping a load in mid-stroke using an external stopper, adjustment bolt or bumper bolt, operate within operating pressure limits shown in the table below. Use caution, as operating the cylinder above these pressures may lead to the breaking of the magnetic coupling.

(The piston speed should be the allowable value or less.)

Bore size [mm]	Allowable pressure for the intermediate stop with an external stopper (Ps) [MPa]
6	0.55
10	
15	
20	0.65
25	
32	
40	

- * Exceeding the allowable pressure will lead to the breaking of the magnetic coupling and cause the piston slider and external slider becoming separated.
- * Fine stroke adjustment for the external slider is also considered as an intermediate stop, so pay attention to the operating pressure.

2. When an intermediate stop is performed with the pneumatic circuit.

When an intermediate stop is performed with the pneumatic circuit with 3 -position solenoid valve, the kinetic energy should be as stated or less than the values in the table below. (The piston speed should be the allowable value or less.)

Bore size [mm]	Allowable kinetic energy for the intermediate stop with the pneumatic circuit (Es) [J]
6	0.007
10	0.03
15	0.13
20	0.24
25	0.45
32	0.88
40	1.53

- * Exceeding the allowable kinetic energy will lead to the breaking of the magnetic coupling and cause the piston slider and external slider becoming separated.

Magnetically Coupled Rodless Cylinder Slider Type/Slide Bearing

CY3S Series

RoHS

∅ 6, ∅ 10, ∅ 15, ∅ 20, ∅ 25, ∅ 32, ∅ 40

How to Order

Slide bearing **CY3S** **25** - **300** **Z** - **M9BW**

Slider type
(Slide bearing)

Piping

Bilateral piping type

Centralised piping type

G

Plate A

P1

P2

* For centralised piping, the port will be placed on the plate A side.

Bore size

6	6 mm
10	10 mm
15	15 mm
20	20 mm
25	25 mm
32	32 mm
40	40 mm

Port thread type

Symbol	Type	Bore size [mm]
—	M thread	6, 10, 15
	Rc	
TN	NPT	20, 25, 32, 40
TF	G	

Standard stroke
Refer to page 18 for standard strokes.

Number of auto switches

—	2
S	1
n	n

Auto switch

—	Without auto switch
---	---------------------

* For applicable auto switches, refer to the table below.

Switch rail

—	With switch rail
N	Without switch rail

* Magnet for auto switch included as standard

Stopper type

—	Bumper bolt (resin tipped): Mounted on both sides	
B	Shock absorber/ Adjustment bolt (metal ended): Mounted on both sides	
BS	Shock absorber/ Adjustment bolt (metal ended): Plate A side Bumper bolt (resin tipped): Plate B side or C side	

Applicable Auto Switches / Refer to the Web catalogue for further information on auto switches.

Type	Special function	Electrical entry	Indicator light	Wiring (Output)	Load voltage		Auto switch model		Lead wire length [m]				Pre-wired connector	Applicable load	
					DC	AC	Perpendicular	In-line	0.5 (-)	1 (M)	3 (L)	5 (Z)			
Solid state auto switch	—	Grommet	Yes	3-wire (NPN)	24 V	5 V, 12 V	—	M9NV	M9N	●	●	●	○	○	IC circuit
				3-wire (PNP)				M9PV	M9P	●	●	●	○	○	
				2-wire				M9BV	M9B	●	●	●	○	○	
				3-wire (NPN)				M9NWV	M9NW	●	●	●	○	○	
	Diagnostic indication (2-colour indicator)			3-wire (PNP)	M9PWV	M9PW	●	●	●	○	○	IC circuit			
				2-wire	M9B WV	M9B W	●	●	●	○	○				
	Water resistant (2-colour indicator)			3-wire (NPN)	M9NAV *1	M9NA *1	○	○	●	○	○	IC circuit			
				3-wire (PNP)	M9PAV *1	M9PA *1	○	○	●	○	○				
				2-wire		12 V		M9BAV *1	M9BA *1	○	○	●	○	○	—
Reed auto switch	—	Grommet	Yes	3-wire (NPN equivalent)	—	5 V	—	A96V	A96	●	●	●	●	○	IC circuit
				2-wire	24 V	12 V	100 V	A93V	A93	●	●	●	●	○*2	—
								A90V	A90	●	●	●	●	○*2	IC circuit

*1 Water-resistant type auto switches can be mounted on the above models, but SMC cannot guarantee water resistance.

*2 The load voltage used is 24 VDC.

* Lead wire length symbols: 0.5 m..... — (Example) M9NW
1 m..... M (Example) M9NWM
3 m..... L (Example) M9NWL
5 m..... Z (Example) M9NWZ

* Auto switches marked with a "○" are produced upon receipt of order.

* Since there are applicable auto switches other than those listed above, refer to page 23 for details.

* For details on auto switches with pre-wired connectors, refer to the **Web catalogue**.

* Auto switches are shipped together with the product but do not come assembled.



Symbol

Rubber bumper
(Magnet type)

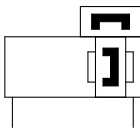

Theoretical Cylinder Thrust

⚠ Caution

When calculating the actual thrust, design should consider the min. operating pressure.

Ø 6, Ø 10

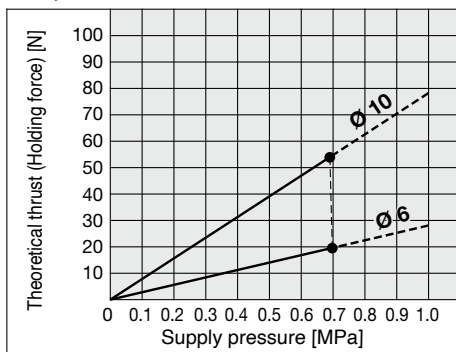

Ø 15, Ø 20, Ø 25, Ø 32, Ø 40

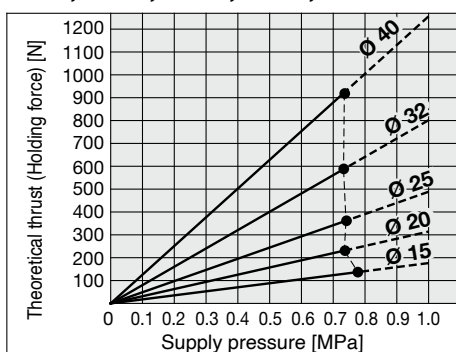

Specifications

Bore size [mm]	6	10	15	20	25	32	40
Fluid	Air						
Proof pressure	1.05 MPa						
Max. operating pressure	0.7 MPa						
Min. operating pressure	0.18 MPa						
Ambient and fluid temperatures	-10 to 60 °C (No freezing)						
Piston speed*1, *2	50 to 800 mm/s						
Cushion	Rubber bumper/Shock absorber						
Lubrication	Non-lube						
Stroke length tolerance [mm]	0 to 250 st: $^{+1.0}_0$, 251 to 1000 st: $^{+1.4}_0$, 1001 st or more: $^{+1.8}_0$						
Magnet holding force [N]	19.6	53.9	137	231	363	588	922

*1 In the case of setting an auto switch at the intermediate position, the maximum piston speed is subject to restrict for detection upon the response time of a load (relays, sequence controller, etc.).

*2 When using a rubber bumper, the max. piston speed is 400 mm/s.

Standard Strokes

Bore size [mm]	Standard stroke [mm]	Max. manufacturable stroke [mm]
6	50, 100, 150, 200	300
10	50, 100, 150, 200, 250, 300	500
15	50, 100, 150, 200, 250, 300, 350, 400, 450, 500	750
20	100, 150, 200, 250, 300, 350, 400, 450, 500, 600, 700, 800	1000
25		1500
32		1500
40	100, 150, 200, 250, 300, 350, 400, 450, 500, 600, 700, 800, 900, 1000	1500

* Intermediate strokes are available in 1 mm increments. (Produced upon receipt of order)

* Minimum stroke available without auto switch is 10 mm and minimum 15 mm for with 2 auto switches.

* Minimum stroke available with 2 auto switches is for when the 2 auto switches are mounted in parallel. For details, refer to page 23.

Weight

Bore size [mm]		6	10	15	20	25	32	40
CY3S□	Basic weight	0.230	0.421	0.717	1.257	1.565	2.763	4.327
	Additional weight per 50 mm of stroke	0.052	0.081	0.110	0.184	0.185	0.284	0.430
CY3SG□	Basic weight	0.234	0.421	0.710	1.224	1.490	2.631	4.187
	Additional weight per 50 mm of stroke	0.050	0.078	0.107	0.176	0.178	0.273	0.413

Calculation: (Example) CY3SG25-500Z

Basic weight (At 0 stroke) ... 1.490 kg Additional weight per 50 mm of stroke ... 0.178 kg

Cylinder stroke ... 500 mm

$1.490 + 0.178 \times 500 \div 50 = 3.27 \text{ kg}$

Shock Absorber Specifications

Applicable cylinder	CY3S□6	CY3S□10	CY3S□15	CY3S□20	CY3S□25	CY3S□32	CY3S□40
Shock absorber model	RJ0604	RJ0806H	RJ0806L	RJ1007L	RJ1412L	RJ2015H	RJ2015L
Max. absorbed energy [J]	0.5	1	3	10	30		
Stroke absorption [mm]	4	6	7	12	15		
Collision speed [m/s]	0.05 to 1	0.05 to 2	0.05 to 1	0.05 to 1	0.05 to 1	0.05 to 2	0.05 to 1
Max. operating frequency [cycle/min]	80	80	70	45	25		
Max. allowable thrust [N]	150	245	422	814	1961		
Ambient temperature [°C]	-10 to 60 °C (No freezing)						

* The max. absorbed energy and max. operating frequency were measured at ordinary temperature (approx. 20 to 25 °C.)

CY3S Series

Construction

CY3S / Bilateral piping type

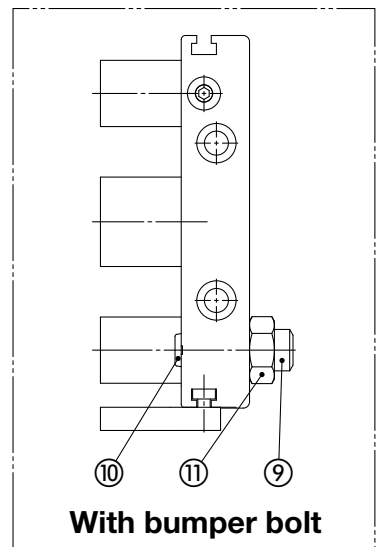
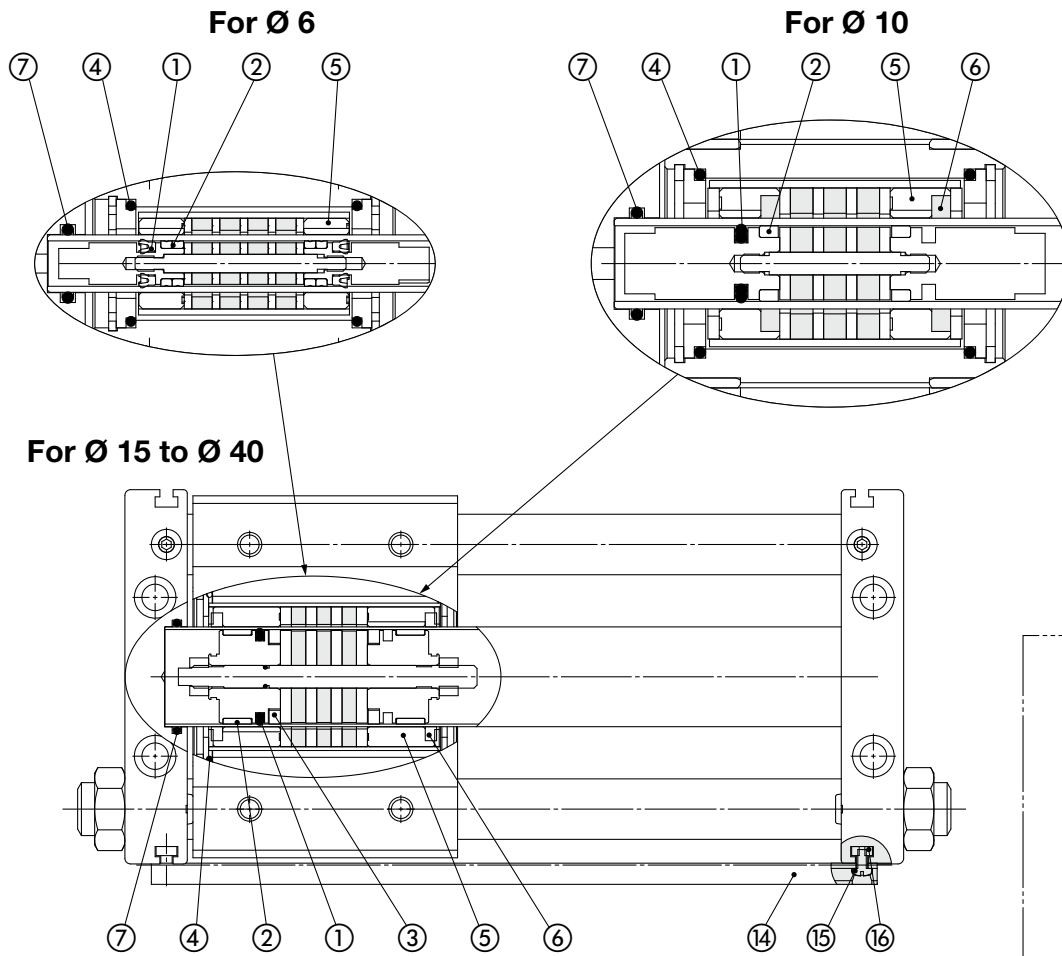

CY3SG / Centralised piping type

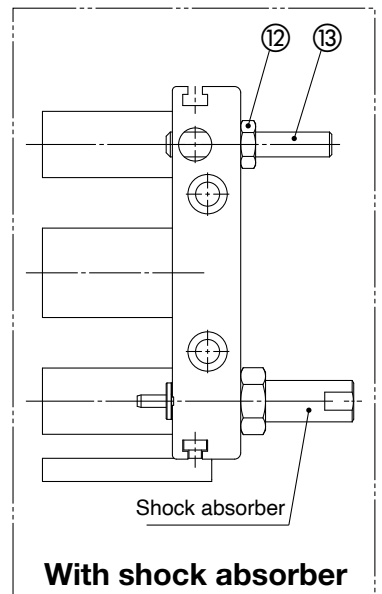
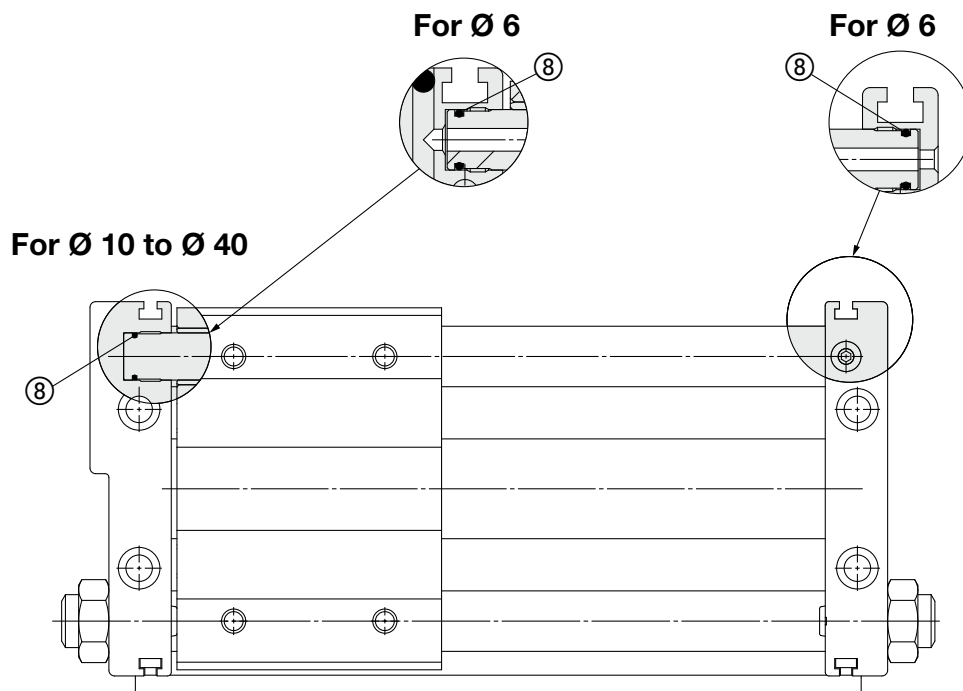

Component Parts

No.	Description
1	Piston seal
2	Wear ring A
3	Lube-retainer A
4	Slider gasket
5	Wear ring B
6	Lube-retainer B
7	Cylinder tube gasket
8	Guide shaft gasket
9	Bumper bolt
10	Bumper
11	Hexagon nut
12	Hexagon nut
13	Adjustment bolt
14	Switch rail
15	Cross recessed round head screw
16	Square nut

Seal Kit

Bore size [mm]	Seal kit	
	Kit no.	Contents
6	CY3S6-Z-PS	Set of nos. 1, 2, 4, 5, 7, 8
10	CY3S10-Z-PS	Set of nos. 1, 4, 5, 6, 7, 8
15	CY3S15-Z-PS	Set of nos. 1 to 8
20	CY3S20-Z-PS	
25	CY3S25-Z-PS	
32	CY3S32-Z-PS	
40	CY3S40-Z-PS	

* The seal kit includes 1, 2, 4, 5, 7, and 8 for Ø 6, 1, 4, 5, 6, 7, and 8 for Ø 10, and 1 to 8 for Ø 15 to Ø 40. Order the seal kit based on each bore size.

* The seal kit includes a grease pack (10 g).

Order with the following part number when only the grease pack is needed.

Grease pack part number: GR-S-010

Replacement Parts

Bore size [mm]	Bumper bolt assembly		Adjustment bolt assembly	
	Kit no.	Contents	Kit no.	Contents
6	CYS06-37-AJ024-R	Set of nos. 9, 10, 11	CYS06-37AAJ024A-R	Set of nos. 12, 13
10	CYS10-37-AJ025-R		CYS10-37AAJ025A-R	
15	CYS20-37-AJ027-R		CYS20-37AAJ027A-R	
20	CYS25-37-AJ028-R		CYS32-37AAJ029A-R	
25	CYS32-37-AJ029-R			
32				
40				

Switch Rail Accessory Kit Nos.

CYS 15 E - 100

Bore size ● Stroke ●

Switch Rail Accessory Kit

Bore size [mm]	Switch rail accessory	Contents
6	CYS6E-□	Set of nos. 14, 15, 16
10	CYS10E-□	
15	CYS15E-□	
20	CYS20E-□	
25	CYS25E-□	
32	CYS32E-□	
40	CYS40E-□	

* □ indicates the stroke.

* CY1S-Z series switch rails cannot be mounted to CY3S-Z series products.

CY3S Series

Dimensions

CY3S / Bilateral piping type

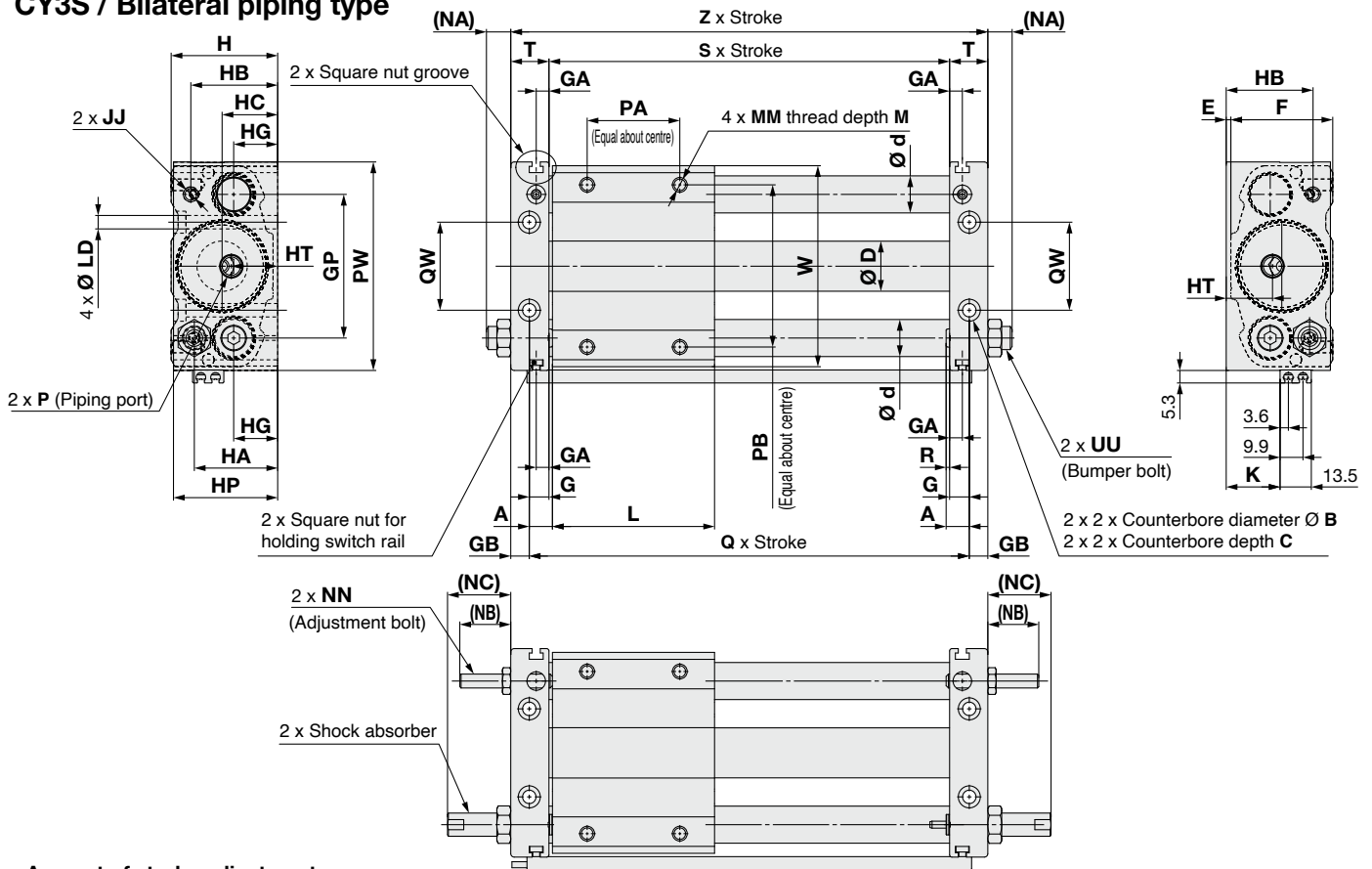

Amount of stroke adjustment

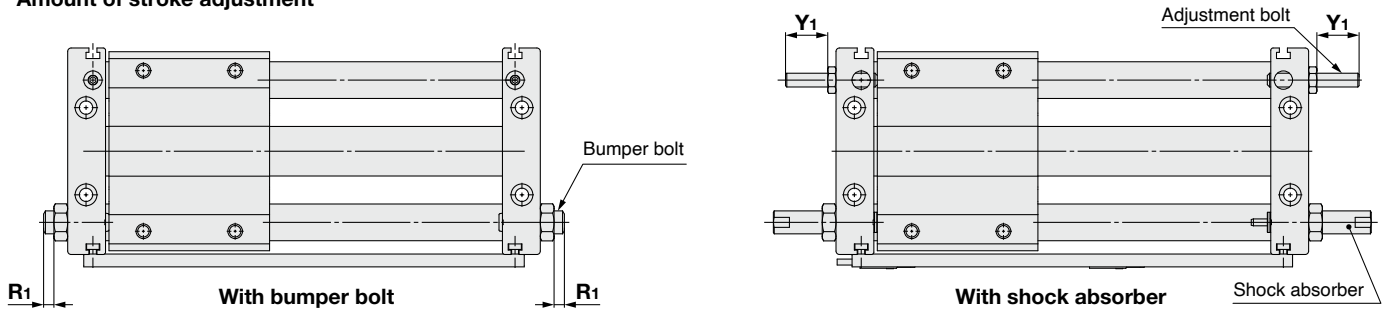

Dimensions

Model	A	B	C	D	d	E	F	G	GA	GB	GP	H	HA	HB	HC	HG	HP	HT	JJ	K	L	LD	M	MM	NA	NB	NC
CY3S6-Z	6	6.5	3.3	7.6	8	2	25	5	5	5	30	27	20.5	20.5	15.5	8	26	15.5	M4 x 0.7	10.2	40	3.5	6	M4 x 0.7	11	14	19
CY3S10-Z	7.5	8	4.4	12	10	2.5	31.5	6.5	5	6	40	34	25	27	17	13.5	33	17	M4 x 0.7	16.2	45	4.6	6	M4 x 0.7	10.5	16.5	28
CY3S15-Z	7.5	9.5	5.4	16.6	12	2	38	6.5	5	6	52	40	28	29.5	20.5	15	39	20.5	M4 x 0.7	18.2	60	5.8	8	M5 x 0.8	10.5	16.5	28
CY3S20-Z	10	9.5	5.4	21.6	16	2	44	8.5	5.5	8	62	46	36	37.5	24	19	45	20	M6 x 1	23.2	70	5.8	10	M6 x 1	10.5	22	28
CY3S25-Z	10	11	6.5	26.4	16	2	52	8.5	5.5	8	70	54	40.5	40.5	27.5	21.5	53	21	M6 x 1	27.2	70	7	10	M6 x 1	12.5	22	49
CY3S32-Z	12.5	14	8.6	33.6	20	2	64	9.5	5.5	9	86	66	50	50	33	26	64	24	M8 x 1.25	33.2	85	9	12	M8 x 1.25	11.5	23.5	52
CY3S40-Z	12.5	14	8.6	41.6	25	2	74	10.5	5.5	10	104	76	55.5	55.5	38	27	74	27	M8 x 1.25	37.2	95	9	12	M8 x 1.25	10.5	22.5	51

Model	NN	P			PA	PB	PW	Q	QW	R	R1	Bumper bolt adjustable range (Both sides: R1 x 2)	S	T	UU	W	Y1	Adjustment bolt adjustable range (Both sides: Y1 x 2)	Z	Shock absorber
		-	TN	TF																
CY3S6-Z	M4 x 0.7	M3 x 0.5	-	-	25	25	49	52	16	1	7.5	15	42	10	M6 x 0.75	46	11.5	23	62	RJ0604N
CY3S10-Z	M4 x 0.7	M5 x 0.8	-	-	25	38	61	60	24	1	5.5	11	47	12.5	M8 x 1	58	14	28	72	RJ0806HN
CY3S15-Z	M5 x 0.8	M5 x 0.8	-	-	30	50	76	75	30	1	5.5	11	62	12.5	M8 x 1	73	14	28	87	RJ0806LN
CY3S20-Z	M6 x 1	Rc1/8	NPT1/8	G1/8	40	70	90	90	38	1.5	4.5	9	73	16.5	M10 x 1	87	18.5	37	106	RJ1007LN
CY3S25-Z	M6 x 1	Rc1/8	NPT1/8	G1/8	40	70	99	90	42	1.5	4.5	9	73	16.5	M14 x 1.5	96	18.5	37	106	RJ1412LN
CY3S32-Z	M8 x 1.25	Rc1/8	NPT1/8	G1/8	40	75	119	110	50	3	5.5	11	91	18.5	M20 x 1.5	116	18.5	37	128	RJ2015HN
CY3S40-Z	M8 x 1.25	Rc1/4	NPT1/4	G1/4	65	105	142	120	64	2	4.5	9	99	20.5	M20 x 1.5	139	17.5	35	140	RJ2015LN

* The figures above show the product with auto switches. Auto switches are shipped together with the product.

Dimensions

CY3SG / Centralised piping type

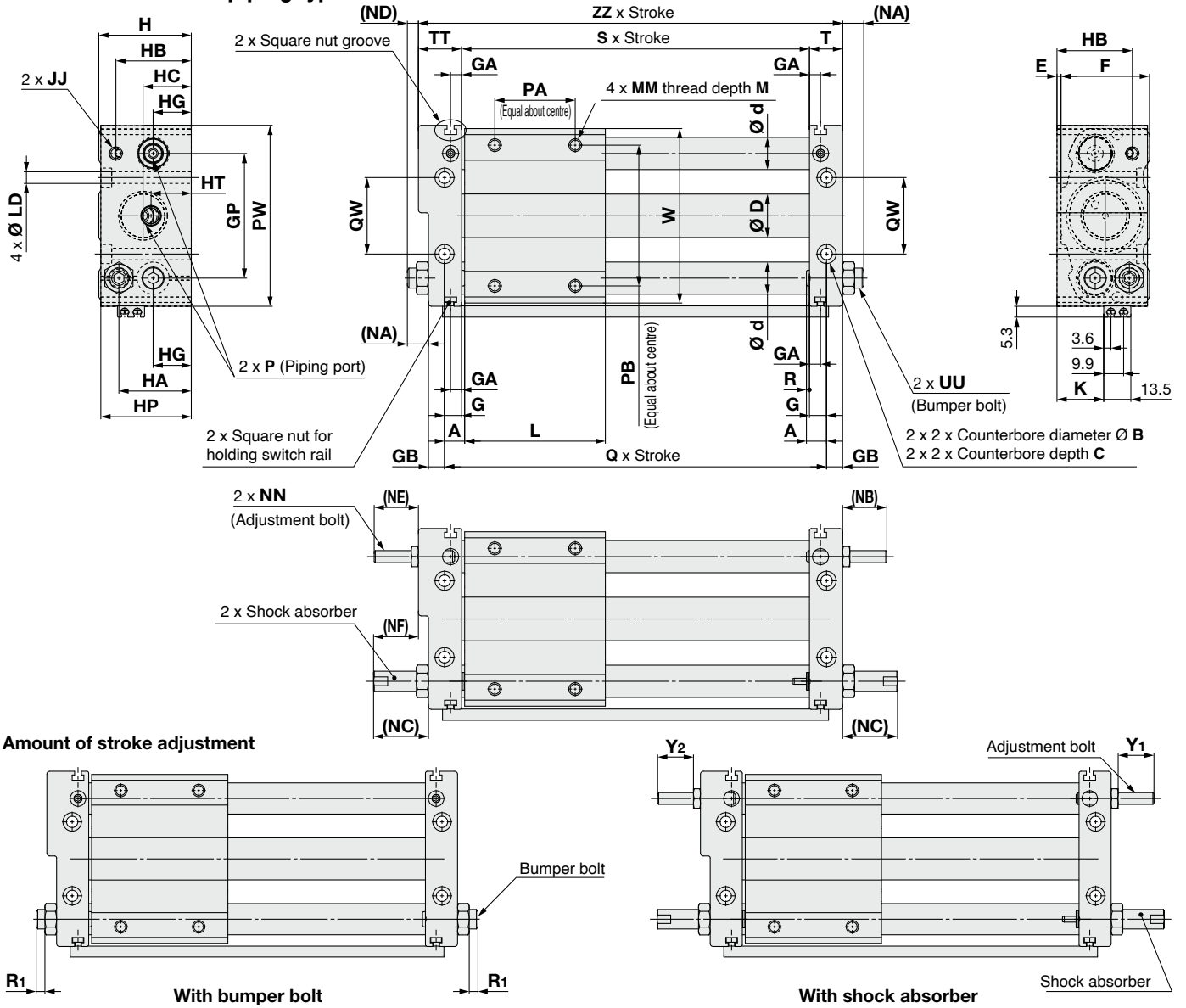

Amount of stroke adjustment

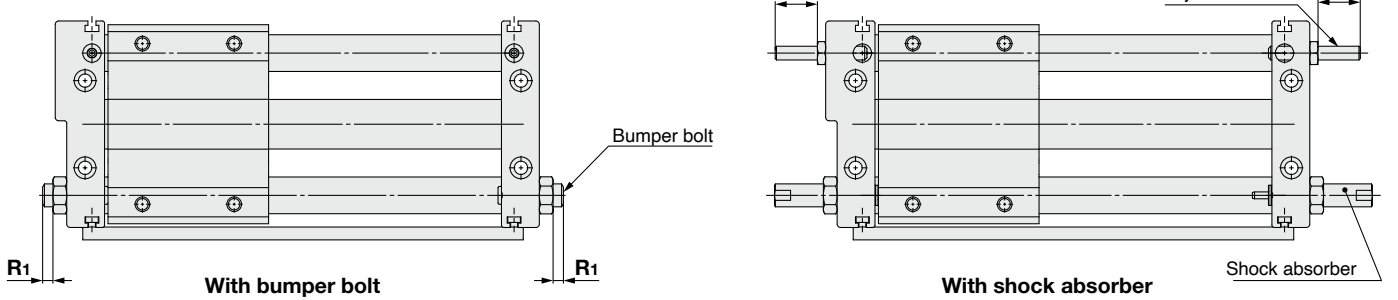

Dimensions

[mm]

Model	A	B	C	D	d	E	F	G	GA	GB	GP	H	HA	HB	HC	HG	HP	HT	JJ	K	L	LD	M	MM	NA	NB	NC	ND	NE
CY3SG6-Z	6	6.5	3.3	7.6	8	2	25	5	5	5	30	27	20.5	20.5	15.5	8	26	15.5	M4 x 0.7	10.2	40	3.5	6	M4 x 0.7	11	14	19	7	10
CY3SG10-Z	7.5	8	4.4	12	10	2.5	31.5	6.5	5	6	40	34	25	27	17	13.5	33	17	M4 x 0.7	16.2	45	4.6	6	M4 x 0.7	10.5	16.5	28	6.5	12.5
CY3SG15-Z	7.5	9.5	5.4	16.6	12	2	38	6.5	5	6	52	40	28	29.5	20.5	15	39	20.5	M4 x 0.7	18.2	60	5.8	8	M5 x 0.8	10.5	16.5	28	5.5	11.5
CY3SG20-Z	10	9.5	5.4	21.6	16	2	44	8.5	5.5	8	62	46	36	37.5	24	19	45	20	M6 x 1	23.2	70	5.8	10	M6 x 1	10.5	22	28	5.5	17
CY3SG25-Z	10	11	6.5	26.4	16	2	52	8.5	5.5	8	70	54	40.5	40.5	27.5	21.5	53	21	M6 x 1	27.2	70	7	10	M6 x 1	12.5	22	49	7.5	17
CY3SG32-Z	12.5	14	8.6	33.6	20	2	64	9.5	5.5	9	86	66	50	50	33	26	64	24	M8 x 1.25	33.2	85	9	12	M8 x 1.25	11.5	23.5	52	5.5	17.5
CY3SG40-Z	12.5	14	8.6	41.6	25	2	74	10.5	5.5	10	104	76	55.5	55.5	38	27	74	27	M8 x 1.25	37.2	95	9	12	M8 x 1.25	10.5	22.5	51	4.5	16.5

Model	NF	NN	P			PA	PB	PW	Q	QW	R	R1	Bumper bolt adjustable range (Both sides: R1 x 2)	S	T	TT	UU	W	Y1	Y2	Adjustment bolt adjustable range (Both sides: Y1 + Y2)	ZZ	Shock absorber
			-	TN	TF																		
CY3SG6-Z	15	M4 x 0.7	M3 x 0.5	-	-	25	25	49	52	16	1	7.5	15	42	10	14	M6 x 0.75	46	11.5	7.5	19	66	RJ0604N
CY3SG10-Z	24	M4 x 0.7	M5 x 0.8	-	-	25	38	61	60	24	1	5.5	11	47	12.5	16.5	M8 x 1	58	14	10	24	76	RJ0806HN
CY3SG15-Z	23	M5 x 0.8	M5 x 0.8	-	-	30	50	76	75	30	1	5.5	11	62	12.5	17.5	M8 x 1	73	14	9	23	92	RJ0806LN
CY3SG20-Z	23	M6 x 1	Rc1/8	NPT1/8	G1/8	40	70	90	90	38	1.5	4.5	9	73	16.5	21.5	M10 x 1	87	18.5	13.5	32	111	RJ1007LN
CY3SG25-Z	44	M6 x 1	Rc1/8	NPT1/8	G1/8	40	70	99	90	42	1.5	4.5	9	73	16.5	21.5	M14 x 1.5	96	18.5	13.5	32	111	RJ1412LN
CY3SG32-Z	46	M8 x 1.25	Rc1/8	NPT1/8	G1/8	40	75	119	110	50	3	5.5	11	91	18.5	24.5	M20 x 1.5	116	18.5	12.5	31	134	RJ2015HN
CY3SG40-Z	45	M8 x 1.25	Rc1/4	NPT1/4	G1/4	65	105	142	120	64	2	4.5	9	99	20.5	26.5	M20 x 1.5	139	17.5	11.5	29	146	RJ2015LN

* The figures above show the product with auto switches. Auto switches are shipped together with the product.

CY3S Series Auto Switch Mounting

Auto Switch Proper Mounting Position (Detection at stroke end)

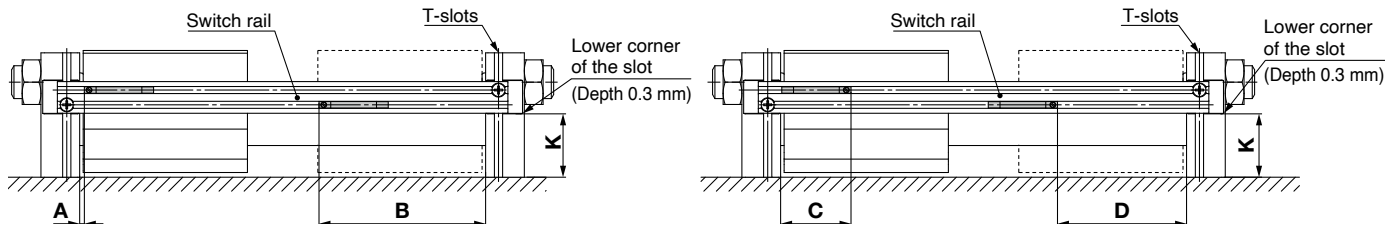

- * The minimum stroke when 2 auto switches are mounted in parallel as shown above is 15 mm.
- * The minimum stroke without auto switch is 10 mm.

Auto Switch Proper Mounting Position

Auto switch model	K dimension (Switch rail height)	A		B		C		D	
		D-M9□ D-M9□V D-M9□W D-M9□WV D-M9□A D-M9□AV	D-A9□ D-A9□V	D-M9□ D-M9□V D-M9□W D-M9□WV D-M9□A D-M9□AV	D-A9□ D-A9□V	D-M9□ D-M9□V D-M9□W D-M9□WV D-M9□A D-M9□AV	D-A9□ D-A9□V	D-M9□ D-M9□V D-M9□W D-M9□WV D-M9□A D-M9□AV	D-A9□ D-A9□V
Bore size									
6	10.2	3	0	39	43	15	19	27	23
10	16.2	3	0	44	48	15	19	32	28
15	18.2	3	0	59	63	15	19	47	43
20	23.2	3.5	0	69.5	73.5	15.5	19.5	57.5	53.5
25	27.2	3.5	0	69.5	73.5	15.5	19.5	57.5	53.5
32	33.2	5	1	86	90	17	21	74	70
40	37.2	4	0	95	99	16	20	83	79

- * The values in the table above are to be used as a reference when mounting auto switches for stroke end detection. Adjust the auto switch after confirming the operating conditions in the actual setting.
- * If the switch rail is reassembled or mounted on the other side of the cylinder, maintain the K dimension (switch rail height: lower corner of the slot) in the table above. The switch rail is secured by screwing the cross-recessed round head screw into a square nut in the T-slots of the end plates. Care must be taken when removing the switch rail so that the screws or nuts are not lost.

Operating Range

Auto switch model	Bore size [mm]						
	6	10	15	20	25	32	40
D-M9□ D-M9□V D-M9□W D-M9□WV D-M9□A D-M9□AV	3.5	3.5	3.5	3.5	4	4	4
D-A9□ D-A9□V	7	7	7	7	7	7.5	7.5

- * Values which include hysteresis are for reference purposes only. They are not a guarantee (assuming approximately ±30 % dispersion) and may change substantially depending on the ambient environment.

Auto Switch Mounting

As shown below, there are 3 ways to mount the auto switch according to 3 types of electrical entries. Insert the auto switch into the auto switch groove. Then use a flat head watchmaker's screwdriver to tighten the included auto switch mounting screws.

Two or more auto switches are also mountable in parallel as shown in the illustrations below.

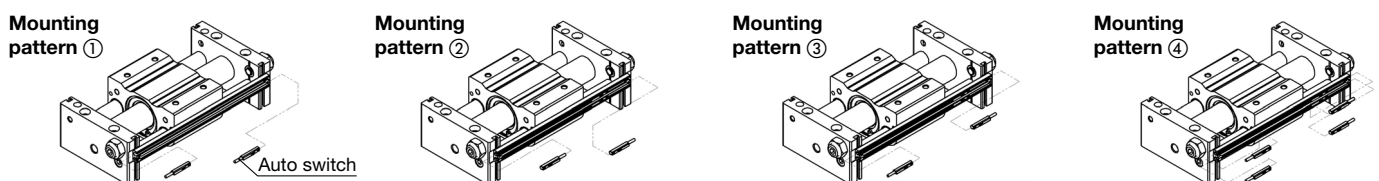

- * When tightening the auto switch mounting screw (included with the auto switch), use a watchmaker's screwdriver with a handle diameter of 5 to 6 mm.

Tightening Torque for Auto Switch Mounting Screw [N·m]

Auto switch model	Tightening torque
D-M9□(V) D-M9□W(V) D-A9□(V)	0.05 to 0.15
D-M9□A(V)	0.05 to 0.10

Other than the applicable auto switches listed in "How to Order," the following auto switches are also mountable.

- * Normally closed (NC = b contact) solid state auto switches (D-M9□E(V)) are also available. For details, refer to the **Web catalogue**.
- * With pre-wired connector is also available for solid state auto switches. For details, refer to the **Web catalogue**.



CY3S Series Specific Product Precautions 1

Be sure to read this before handling the products. Refer to the back cover for safety instructions. For actuator and auto switch precautions, refer to the “Handling Precautions for SMC Products” and the “Operation Manual” on the SMC website: <https://www.smc.eu>

Operating Precautions

Warning

1. **Be careful to the space between the plates and the slide block.**

Take sufficient care to avoid getting your hands or fingers caught when the cylinder is operated.

2. **Do not apply a load to a cylinder which is greater than the allowable value stated in the “Model Selection” pages.**

This can cause a malfunction.

3. **Be careful to the supply pressure and kinetic energy when performing an intermediate stop.**

Fine end stroke adjustment is considered as an intermediate stop, so the considerations for an intermediate stop must be observed when making any fine adjustments.

When stopping the external slider in an intermediate position with an external stopper.

If the allowable pressure values are exceeded, the stopper position might be displaced or the external slider may become detached from the magnetic coupling and drop.

When stopping the piston slider in an intermediate position with the pneumatic circuit.

If the allowable kinetic energy values are exceeded, the stopper position might be displaced or the external slider may become detached from the magnetic coupling and drop.

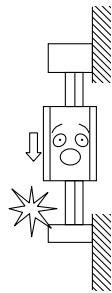

4. **Do not use the cylinder in an environment where the cylinder is exposed to moisture, adhesive foreign matter, dust or liquid such as water or cutting fluid.**

Consider a special order product if the cylinder is to be used in an environment that deteriorates the lubrication of the cylinder sliding parts.

Mounting

Caution

1. **Avoid operation with the external slider secured to the surface.**

Secure the cylinder with the plates on both sides.

2. **Make sure that the cylinder mounting surface has a flatness of 0.2 mm or less.**

If the flatness of the mounting surface is not appropriate, the 2 guide shafts will become twisted and have an adverse effect to the performance of the product. This results in reduction of product life due to the increase in sliding resistance and premature wearing of the bushing.

The flatness of the cylinder mounting surface should be 0.2 mm or less, and the product should be mounted so that it can operate smoothly over the full stroke with the minimum operating pressure (0.18 MPa or less).

3. **Do not operate with the magnetic coupling out of position.**

In case the magnetic coupling is out of position, push the external slider back into the correct position by hand at the end of the stroke (or correct the piston slider with air pressure).

Disassembly and Maintenance

Warning

1. **When disassembling the cylinder, be sure to carefully handle it. The adsorption force of the magnet is very strong.**

Handle with caution when removing the external slider and piston slider from the cylinder tube for maintenance, etc. For details, refer to the Operation Manual.

Stroke Setting

Caution

With bumper bolt

Loosen the hexagon nut, and move the bumper bolt to the set stroke position with a hexagon wrench or by hand. Tighten the hexagon nut to the torque values shown in the table below.

With shock absorber

The cylinder stroke is controlled by the position of the adjustment bolt. Parallel pins of smaller size to the rod diameter of the shock absorber are mounted on the slide block, and these pins collide with the adjustment bolt and shock absorber. Therefore, the stopper of the shock absorber should not come into contact with the slide block directly. (See the figure below.)

It is possible to adjust the stroke time of the shock absorber by adjusting the position of the shock absorber and adjustment bolt. However, if the effective stroke of the shock absorber is extremely short, the ability to absorb the impact will be reduced, leading to failure. Therefore, the position of the shock absorber is recommended to be approximately 0.2 mm behind the contact surface of the adjustment bolt (See figure below).

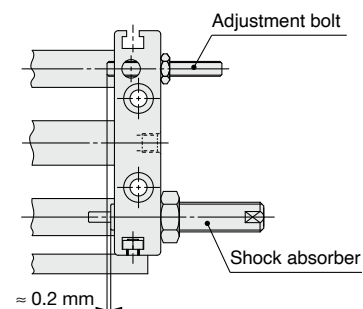

Bore size [mm]	Nut for bumper bolt		Nut for shock absorber		Nut for adjustment bolt	
	Thread size	Tightening torque [N·m]	Thread size	Tightening torque [N·m]	Thread size	Tightening torque [N·m]
6	M6 x 0.75	5.2	M6 x 0.75	0.85	M4 x 0.7	1.5
10	M8 x 1	12.5	M8 x 1	1.67		
15						
20	M10 x 1	24.5	M10 x 1	3.14	M6 x 1	5.2
25	M14 x 1.5	68.0	M14 x 1.5	10.80		
32	M20 x 1.5	204.0	M20 x 1.5	23.50		
40						



CY3S Series

Specific Product Precautions 2

Be sure to read this before handling the products. Refer to the back cover for safety instructions. For actuator and auto switch precautions, refer to the “Handling Precautions for SMC Products” and the “Operation Manual” on the SMC website: <https://www.smc.eu>

Caution when Replacing Shock Absorber

Caution

For the cylinder specification of shock absorber with adjustment bolt, the stroke will be maintained even when the shock absorber is replaced. However, if the position of the adjustment bolt is also changed, it will be necessary to reset the stroke position of the cylinder and shock absorber.

Service Life and Replacement Period of Shock Absorber

Caution

1. If the shock absorbing ability of the shock absorber is insufficient at the end of stroke, the cylinder, equipment or workpiece maybe damaged.
2. Perform maintenance for the shock absorber (RJ series) setting approximately 3 million operating cycles as a guide.
 - * The performance may vary depending on the operating conditions of the shock absorber.
 - * As a guide, the maintenance check for the shock absorber (RJ series) should be carried out after approximately 3 million operating cycles, and replace if necessary.
3. Refer to the RJ series catalogue for Specific Product Precautions of the shock absorber.

Safety Instructions

These safety instructions are intended to prevent hazardous situations and/or equipment damage. These instructions indicate the level of potential hazard with the labels of “Caution,” “Warning” or “Danger.” They are all important notes for safety and must be followed in addition to International Standards (ISO/IEC)¹⁾, and other safety regulations.

 **Danger:** **Danger** indicates a hazard with a high level of risk which, if not avoided, will result in death or serious injury.

 **Warning:** **Warning** indicates a hazard with a medium level of risk which, if not avoided, could result in death or serious injury.

 **Caution:** **Caution** indicates a hazard with a low level of risk which, if not avoided, could result in minor or moderate injury.

- 1) ISO 4414: Pneumatic fluid power – General rules and safety requirements for systems and their components.
- ISO 4413: Hydraulic fluid power – General rules and safety requirements for systems and their components.
- IEC 60204-1: Safety of machinery – Electrical equipment of machines. (Part 1: General requirements)
- ISO 10218-1: Robots and robotic devices - Safety requirements for industrial robots - Part 1: Robots.
- etc.

Warning

1. The compatibility of the product is the responsibility of the person who designs the equipment or decides its specifications.

Since the product specified here is used under various operating conditions, its compatibility with specific equipment must be decided by the person who designs the equipment or decides its specifications based on necessary analysis and test results. The expected performance and safety assurance of the equipment will be the responsibility of the person who has determined its compatibility with the product. This person should also continuously review all specifications of the product referring to its latest catalogue information, with a view to giving due consideration to any possibility of equipment failure when configuring the equipment.

2. Only personnel with appropriate training should operate machinery and equipment.

The product specified here may become unsafe if handled incorrectly. The assembly, operation and maintenance of machines or equipment including our products must be performed by an operator who is appropriately trained and experienced.

3. Do not service or attempt to remove product and machinery/equipment until safety is confirmed.

1. The inspection and maintenance of machinery/equipment should only be performed after measures to prevent falling or runaway of the driven objects have been confirmed.
2. When the product is to be removed, confirm that the safety measures as mentioned above are implemented and the power from any appropriate source is cut, and read and understand the specific product precautions of all relevant products carefully.
3. Before machinery/equipment is restarted, take measures to prevent unexpected operation and malfunction.

4. SMC products cannot be used beyond their specifications. They are not developed, designed, and manufactured to be used under the following conditions or environments.

Use under such conditions or environments is not allowed.

1. Conditions and environments outside of the given specifications, or use outdoors or in a place exposed to direct sunlight.
2. Use for nuclear power, railways, aviation, space equipment, ships, vehicles, military application, equipment affecting human life, body, and property, combustion equipment, entertainment equipment, emergency shut-off circuits, press clutches, brake circuits, safety equipment, etc., and use for applications that do not conform to standard specifications such as catalogues and operation manuals.
3. Use for interlock circuits, except for use with double interlock such as installing a mechanical protection function in case of failure. Please periodically inspect the product to confirm that the product is operating properly.

Caution

SMC develops, designs, and manufactures products to be used for automatic control equipment, and provides them for peaceful use in manufacturing industries.

Use in non-manufacturing industries is not allowed.

Products SMC manufactures and sells cannot be used for the purpose of transactions or certification specified in the Measurement Act of each country.

The new Measurement Act prohibits use of any unit other than SI units in Japan.

Limited warranty and Disclaimer/Compliance Requirements

The product used is subject to the following “Limited warranty and Disclaimer” and “Compliance Requirements”. Read and accept them before using the product.

Limited warranty and Disclaimer

1. The warranty period of the product is 1 year in service or 1.5 years after the product is delivered, whichever is first.²⁾ Also, the product may have specified durability, running distance or replacement parts. Please consult your nearest sales branch.
2. For any failure or damage reported within the warranty period which is clearly our responsibility, a replacement product or necessary parts will be provided. This limited warranty applies only to our product independently, and not to any other damage incurred due to the failure of the product.
3. Prior to using SMC products, please read and understand the warranty terms and disclaimers noted in the specified catalogue for the particular products.

2) Suction cups (Vacuum pads) are excluded from this 1 year warranty.

A suction cup (vacuum pad) is a consumable part, so it is warranted for a year after it is delivered. Also, even within the warranty period, the wear of a product due to the use of the suction cup (vacuum pad) or failure due to the deterioration of rubber material are not allowed by the limited warranty.

Compliance Requirements

1. The use of SMC products with production equipment for the manufacture of weapons of mass destruction (WMD) or any other weapon is strictly prohibited.
2. The exports of SMC products or technology from one country to another are governed by the relevant security laws and regulations of the countries involved in the transaction. Prior to the shipment of a SMC product to another country, assure that all local rules governing that export are known and followed.

Safety Instructions

Be sure to read the “Handling Precautions for SMC Products” (M-E03-3) and “Operation Manual” before use.

SMC Corporation (Europe)

Austria	+43 (0)2262622800	www.smc.at	office.at@smc.com
Belgium	+32 (0)33551464	www.smc.be	info@smc.be
Bulgaria	+359 (0)2807670	www.smc.bg	sales.bg@smc.com
Croatia	+385 (0)13707288	www.smc.hr	sales.hr@smc.com
Czech Republic	+420 541424611	www.smc.cz	office.at@smc.com
Denmark	+45 70252900	www.smc.dk.com	smc.dk@smc.com
Estonia	+372 651 0370	www.smcee.ee	info.ee@smc.com
Finland	+358 207513513	www.smc.fi	smc.fi@smc.com
France	+33 (0)164761000	www.smc-france.fr	supportclient.fr@smc.com
Germany	+49 (0)61034020	www.smc.de	info.de@smc.com
Greece	+30 210 2717265	www.smchellas.gr	sales@smchellas.gr
Hungary	+36 23513000	www.smc.hu	office.hu@smc.com
Ireland	+353 (0)14039000	www.smcautomation.ie	technical.ie@smc.com
Italy	+39 03990691	www.smcitalia.it	mailbox.it@smc.com
Latvia	+371 67817700	www.smc.lv	info.lv@smc.com

Lithuania	+370 5 2308118	www.smclt.lt	info.lt@smc.com
Netherlands	+31 (0)205318888	www.smc.nl	info@smc.nl
Norway	+47 67129020	www.smc-norge.no	post.no@smc.com
Poland	+48 22 344 40 00	www.smc.pl	office.pl@smc.com
Portugal	+351 214724500	www.smc.eu	apoiocliente.pt@smc.com
Romania	+40 213205111	www.smcromania.ro	office.ro@smc.com
Russia	+7 (812)3036600	www.smc.eu	sales@smcru.com
Slovakia	+421 (0)413213212	www.smc.sk	sales.sk@smc.com
Slovenia	+386 (0)73885412	www.smc.si	office.si@smc.com
Spain	+34 945184100	www.smc.eu	post.es@smc.com
Sweden	+46 (0)86031240	www.smc.nu	order.se@smc.com
Switzerland	+41 (0)523963131	www.smc.ch	helpcenter.ch@smc.com
Turkey	+90 212 489 0 440	www.smcturkey.com.tr	satis.tr@smc.com
UK	+44 (0)845 121 5122	www.smc.uk	sales.gb@smc.com
South Africa	+27 10 900 1233	www.smcza.co.za	Sales.za@smc.com