

Dual Rod Cylinder

Ø 6, Ø 10, Ø 16, Ø 20, Ø 25, Ø 32

New

RoHS

Allowable kinetic energy

0.016 J

7 times

New CXS2

0.016

Existing product CXS

0.0023

Allowable kinetic energy [J] * Compared at a Ø 6

Max. piston speed

800 mm/s

2.6 times

New CXS2

800

Existing product CXS

300

Piston speed [mm/s] * Compared at a Ø 6

Max.
standard
stroke
increased

Ø 6

50 mm ▶ **100 mm**

Ø 10

75 mm ▶ **150 mm**

Ø 16 to Ø 32

100 mm ▶ **200 mm**

Mounting dimensions are compatible with the existing CXS series products.



CXS2 Series



CAT.EUS20-275A-UK

Double piston construction provides twice the output force.

Two types of bearings are available as standard.

- Ball bushing bearing
- Slide bearing

Piston diameter increased up to 16 mm

Same external dimensions as the 15 mm bore size version but the output force increased by approx. 14 %

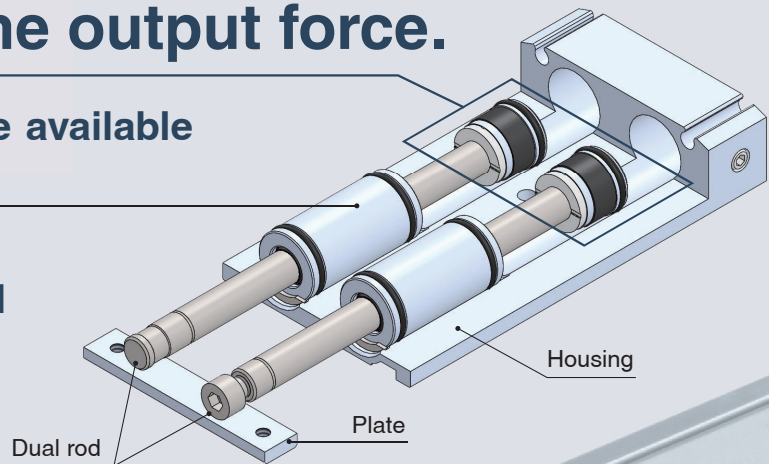

Weight: 7 % reduction

0.15 kg → 0.14 kg

(Compared with the CXS□ series, Ø 10, 10 mm stroke)

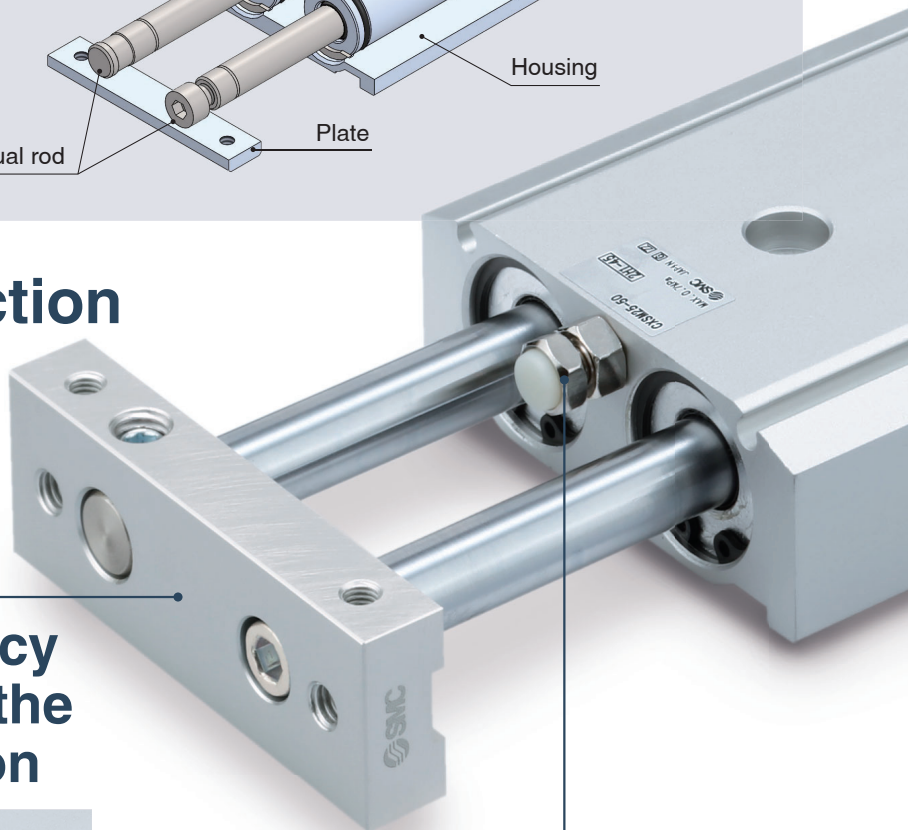

Non-rotating accuracy of $\pm 0.1^\circ$ because of the dual rod construction



Stroke is adjustable up to **-5 mm**.

Compact auto switches are mountable.
(D-M9□, D-A9□)

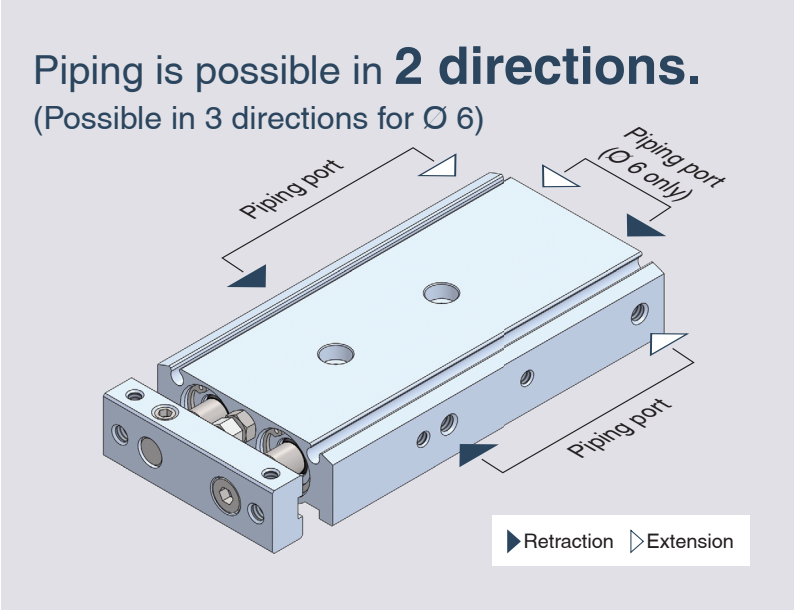
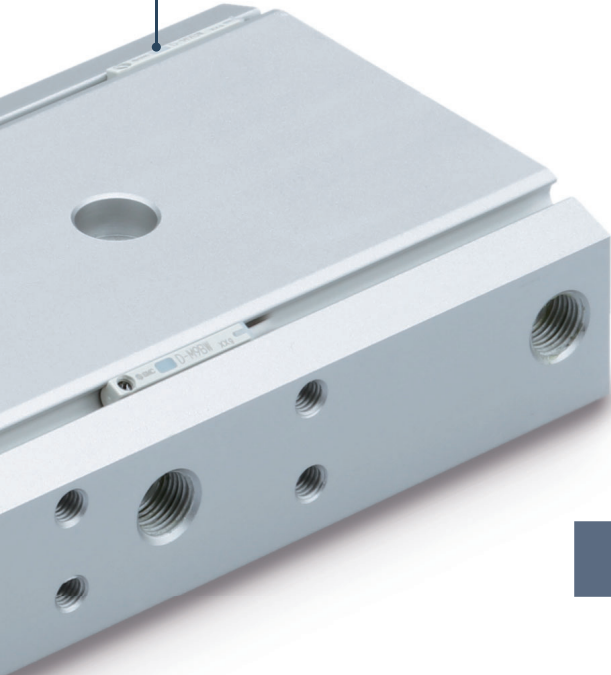



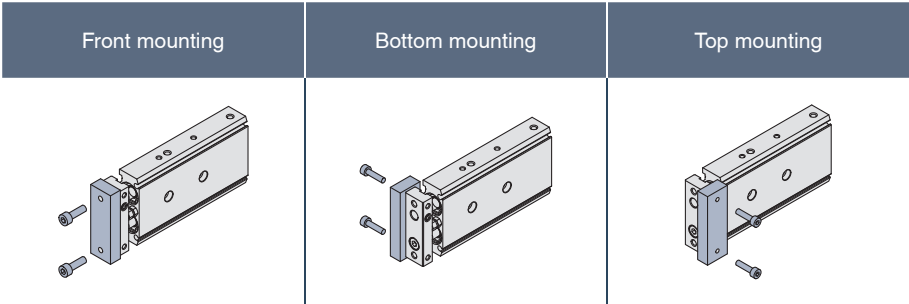



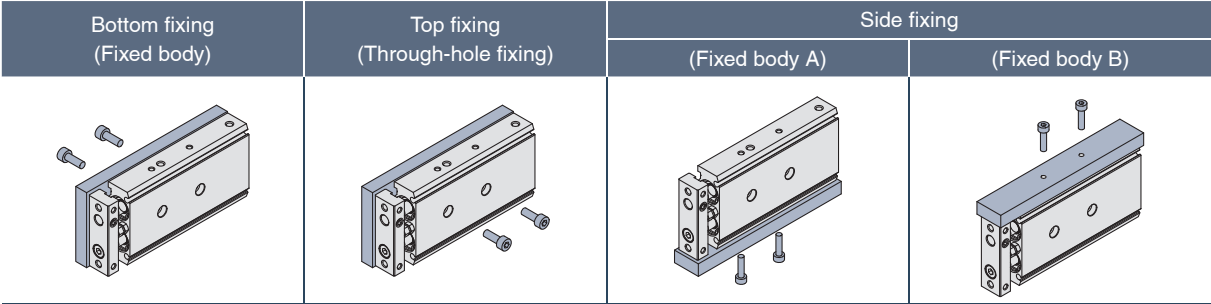



Workpiece can be mounted from **3 directions**.



Body can be mounted from **4 directions**.



Series Variations

Series/Model	Bearing type	Bore size [mm]											Standard stroke [mm]	Axial piping	Clean series (10-series)	Cylinder with stable lubrication function (Lube-retainer)	Page		
		6	10	12	16 /15	20	25	32	40	50	63	80						100	
New Basic type/ CXS2 	Slide bearing														Ø 6: 10 to 100 Ø 10: 10 to 150 Ø 16 to Ø 32: 10 to 200	 (Ø 6)	—	—	p. 11
	Ball bushing bearing	●	●	—	●	●	●	—	—	—	—	—	—						
Compact type/ CXSJ 		●	●	—	●	●	●	—	—	—	—	—	—	Ø 6: 10 to 50 Ø 10: 10 to 75 Ø 16 to Ø 32: 10 to 100	 (Ø 6, Ø 10)	—	—		
Basic type/ CXS 		●	●	—	●	●	●	—	—	—	—	—	—	Ø 6: 10 to 50 Ø 10: 10 to 75 Ø 15 to Ø 32: 10 to 100	 (Ø 6)	●	●		
With air cushion/ CXS-□A 	Slide bearing													Ø 20 to Ø 32: 10 to 100	—	—	—		
	Ball bushing bearing	—	—	—	—	●	●	●	—	—	—	—	—						
With end lock for retraction side/ CXS-□R 		●	●	—	●	●	●	—	—	—	—	—	—	Ø 6 to Ø 15: 10 to 50 Ø 20 to Ø 32: 10 to 100	 (Ø 6)	—	—		
Double rod type/ CXSW 		●	●	—	●	●	●	—	—	—	—	—	—	Ø 6 to Ø 15: 10 to 50 Ø 20 to Ø 32: 10 to 100	—	—	—		
Basic type/ JMGP 	Slide bearing	—	—	●	●	●	●	●	●	●	●	●	●	Ø 12, Ø 16: 10 to 100 Ø 20, Ø 25: 20 to 150 Ø 32 to Ø 100: 20 to 200	—	—	—		

Catalogue on www.smc.eu

CONTENTS

Dual Rod Cylinder *CXS2 Series*

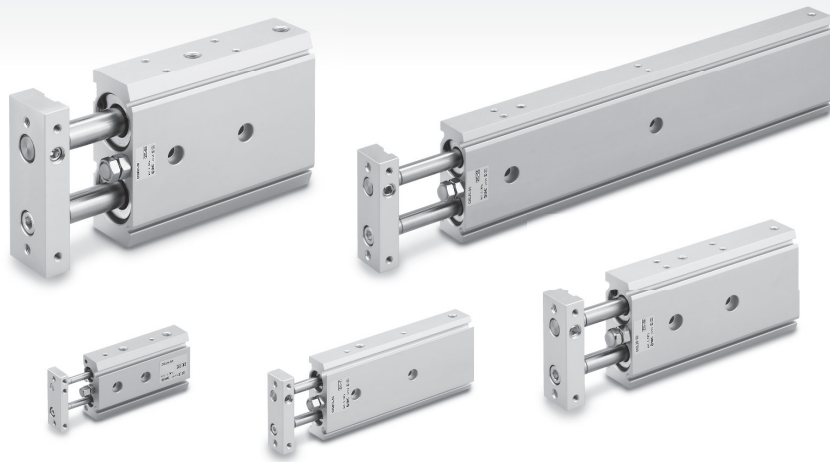

● Model Selection	p. 5
How to Order	p. 11
Specifications	p. 12
Construction: Slide Bearing	p. 14
Construction: Ball Bushing Bearing	p. 15
Dimensions	p. 16
● Auto Switch Mounting	p. 19
● Prior to Use	
Auto Switch Connections and Examples	p. 20
Specific Product Precautions	p. 21

CXS2 Series

Model Selection: Basic Type

⚠ Caution Confirmation of theoretical output is required separately.
Refer to the "Theoretical Output" on page 12.

Basic Type: CXS2

Vertical Mounting

Mounting orientation					
	Up to 200		Up to 400		
Max. speed [mm/s]	Up to 200		Up to 400		
Stroke [mm]	All strokes				
Selection graph	○ 6	1	2	3	4
	○ 10	5	6	7	8
	○ 16				
	○ 20				
	○ 25				
	○ 32				

* Max. speeds are: ○ 6/○ 10: 800 mm/s, ○ 16/○ 20: 700 mm/s, and ○ 25/○ 32: 600 mm/s.

Horizontal Mounting

Mounting orientation									
	Up to 10		Up to 30						
Stroke [mm]	Up to 10		Up to 30						
Max. speed [mm/s]	Up to 400	Over 400	Up to 400	Over 400					
Selection graph	○ 6	9	10	11	12	13			
	○ 10	14	15	16	17	18	19	20	21
	○ 16								
	○ 20								
	○ 25								
	○ 32								

* Max. speeds are: ○ 6/○ 10: 800 mm/s, ○ 16/○ 20: 700 mm/s, and ○ 25/○ 32: 600 mm/s.

⚠ Caution

If the cylinder is horizontally mounted and the plate end does not reach the load's centre of gravity, use the formula below to calculate the imaginary stroke L' that includes the distance between the load's centre of gravity and the plate end. Select the graph that corresponds to the imaginary stroke L'.

$$\text{Imaginary stroke } L' = (\text{Stroke}) + k + L$$

k: Distance between the centre and end of the plate

○ 6	2.75 mm
○ 10	4 mm
○ 16	5 mm
○ 20	6 mm
○ 25	
○ 32	8 mm

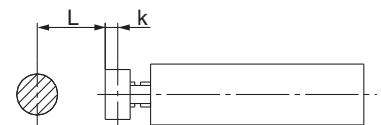

(Example)

When using CXS2M6-10 and L = 15 mm:

$$\text{Imaginary stroke } L' = 10 + 2.75 + 15 = 27.75$$

Therefore, the graph used for your model selection should be the one for CXS2M6-30.

Vertical Mounting

∅ 6

Graph (1) V = 200 (mm/s)

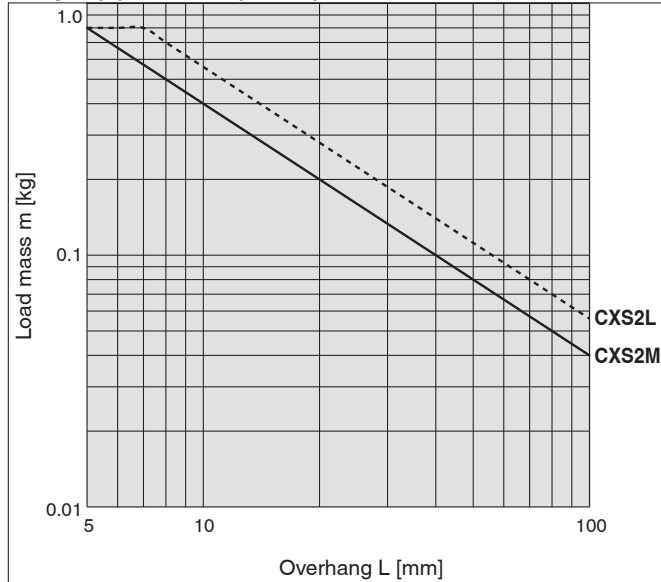

Graph (2) V = 400 (mm/s)

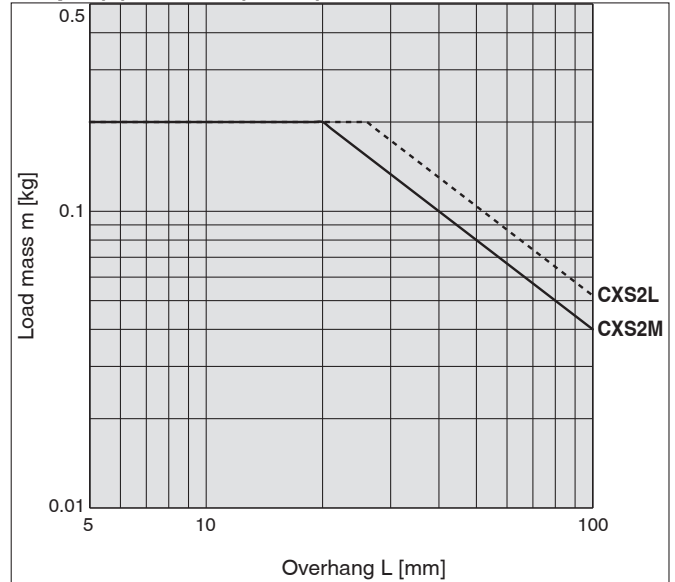

Graph (3) V = 600 (mm/s)

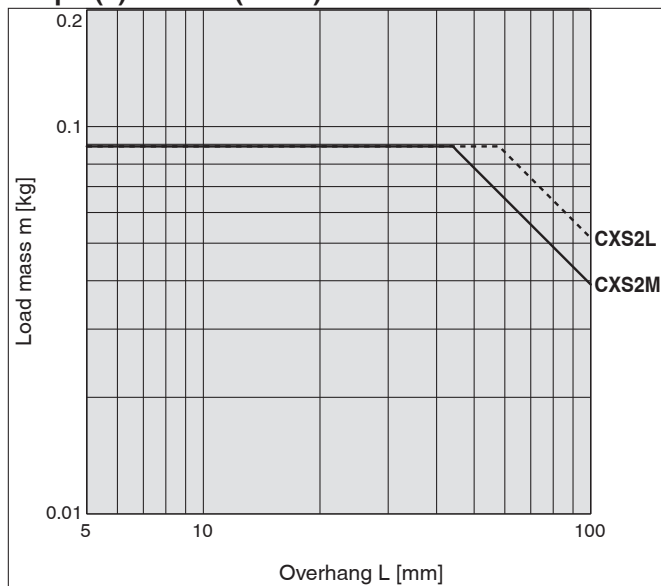

Graph (4) V = 800 (mm/s)

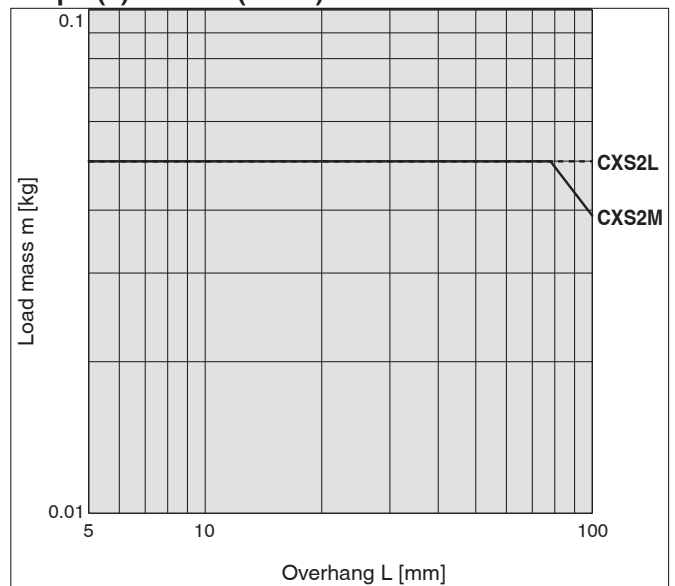

CXS2 Series

Vertical Mounting

Ø 10 to Ø 32

Graph (5) V = 200 (mm/s)

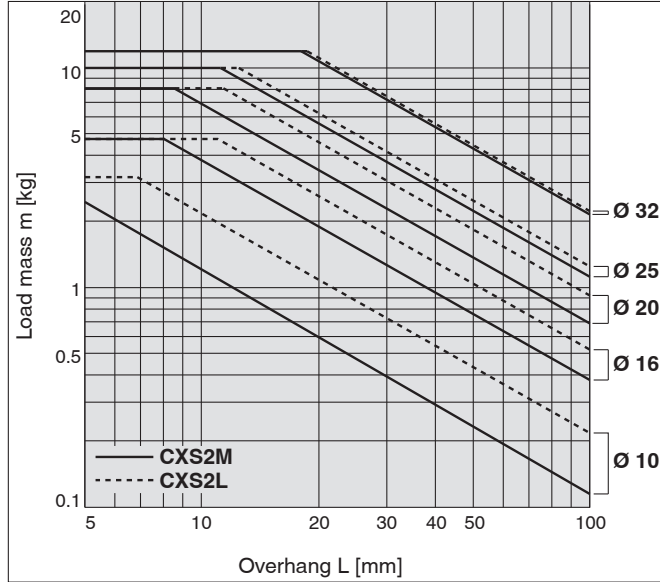

Graph (6) V = 400 (mm/s)

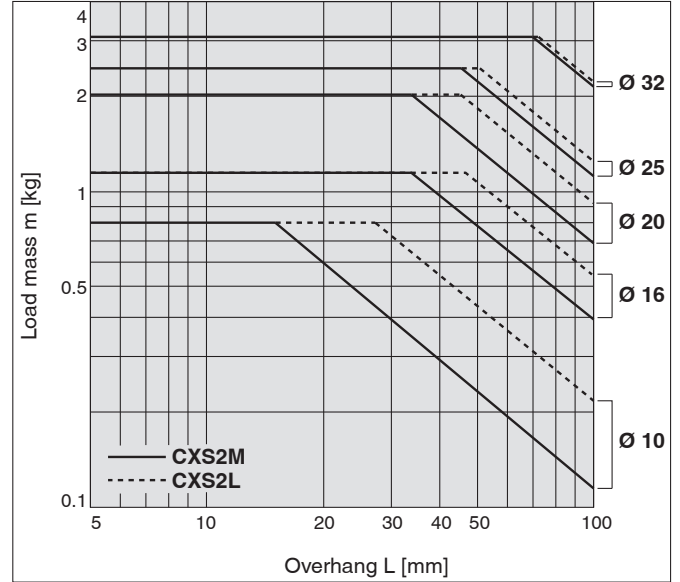

Graph (7) V = 600 (mm/s)

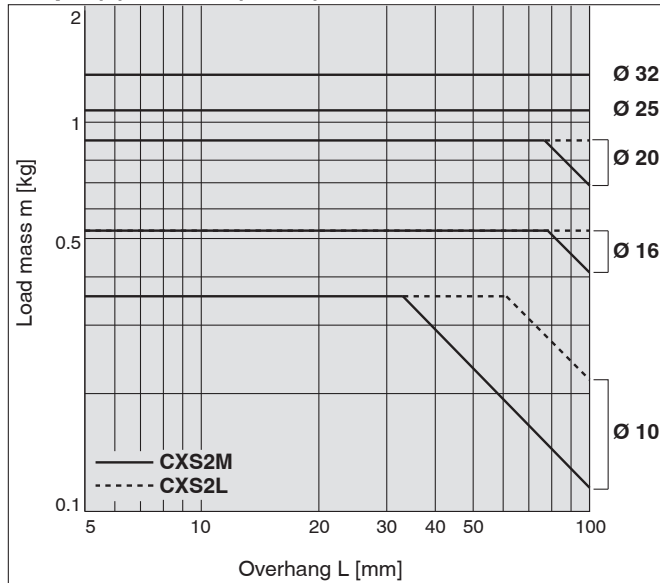

Graph (8) V = 700 (mm/s) (800 mm/s for Ø 10)

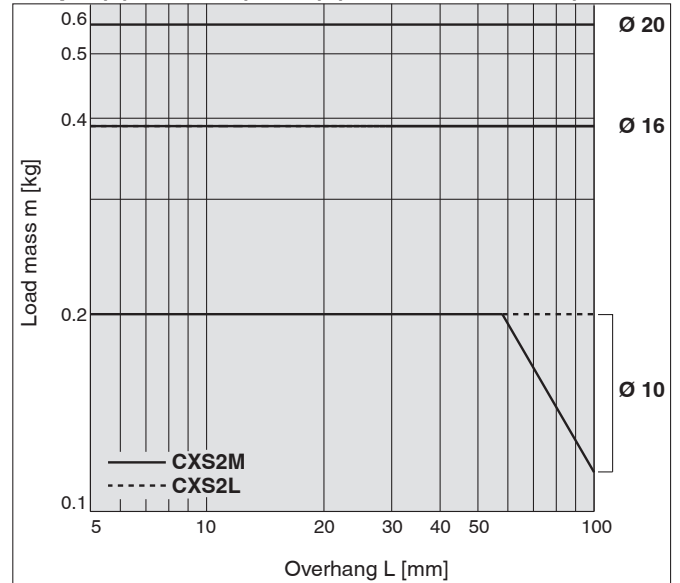

Horizontal Mounting

Ø 6

Graph (9) Up to 10 stroke

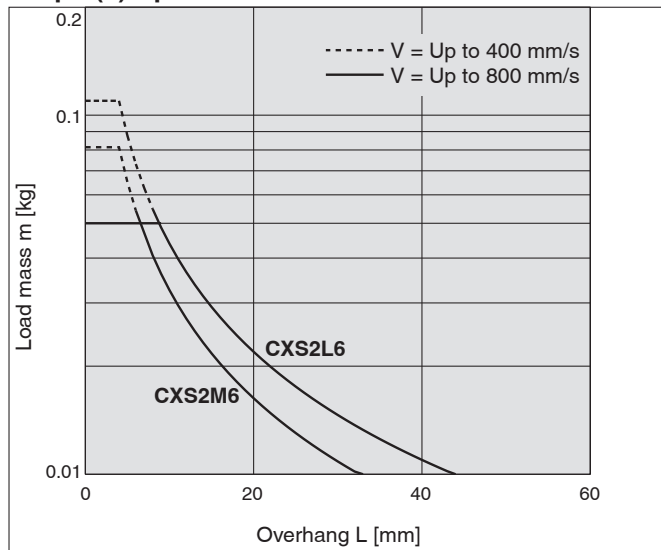

Graph (10) Up to 30 stroke

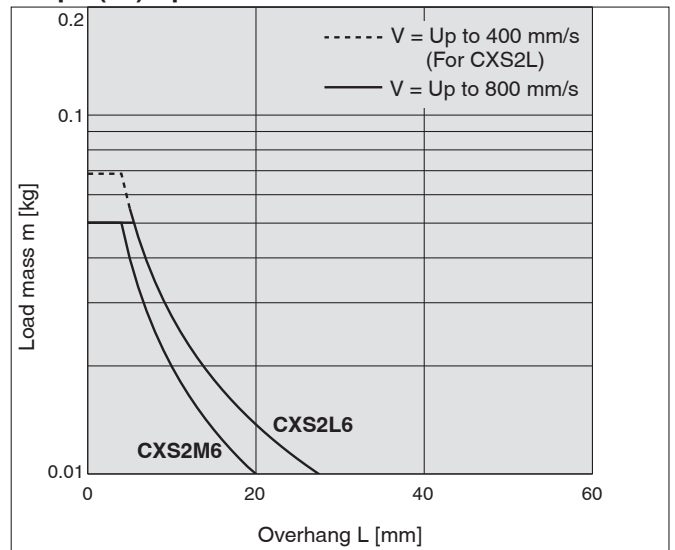

Graph (11) Up to 50 stroke

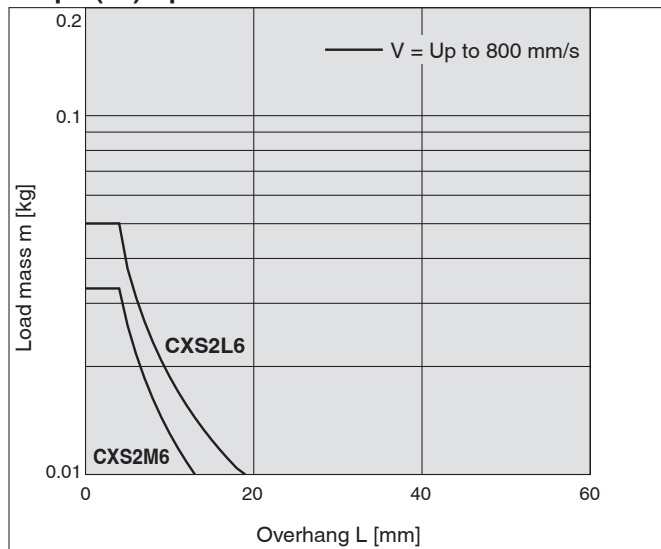

Graph (12) Up to 75 stroke

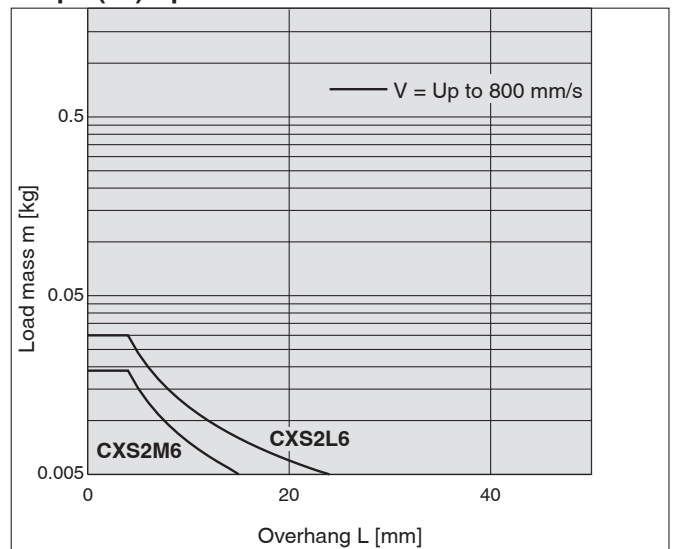

Graph (13) Up to 100 stroke

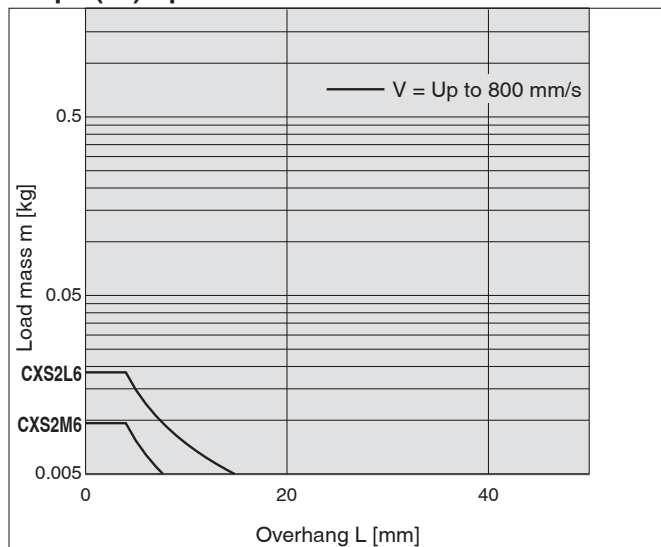

CXS2 Series

Horizontal Mounting

Ø 10 to Ø 32

Graph (14) V = Up to 400 mm/s; Up to 10 stroke

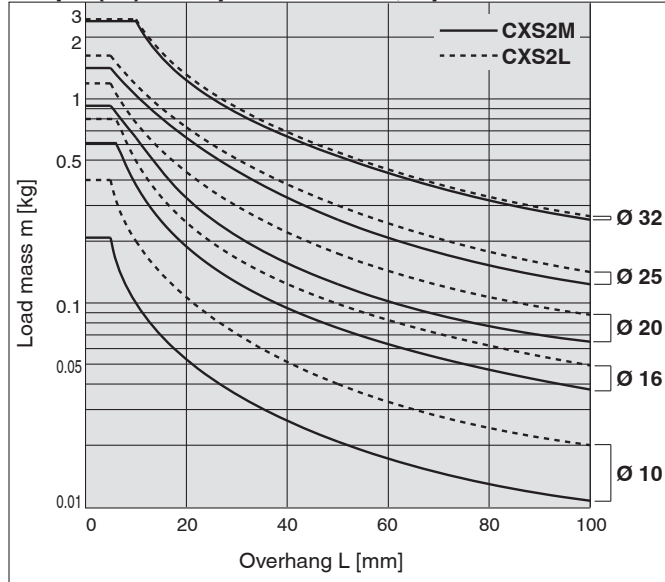

Graph (15) V = Over 400 mm/s; Up to 10 stroke

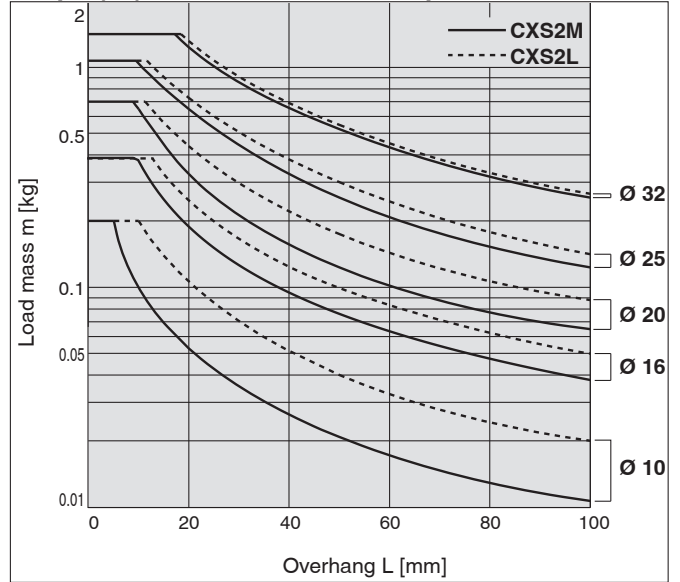

Graph (16) V = Up to 400 mm/s; Up to 30 stroke

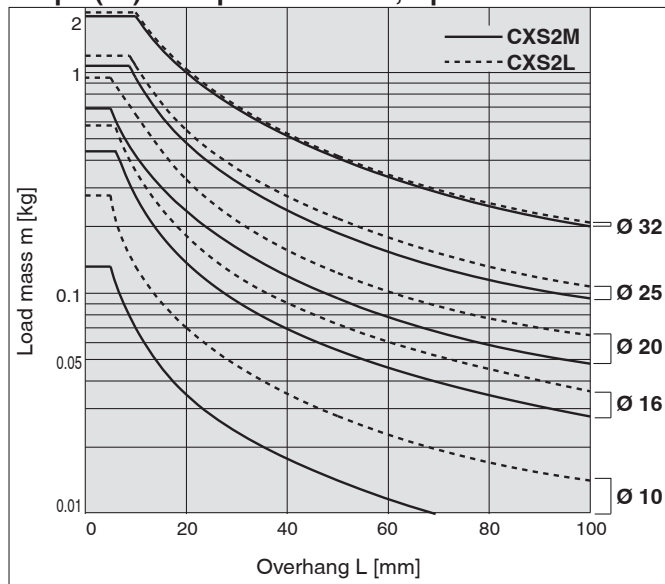

Graph (17) V = Over 400 mm/s; Up to 30 stroke

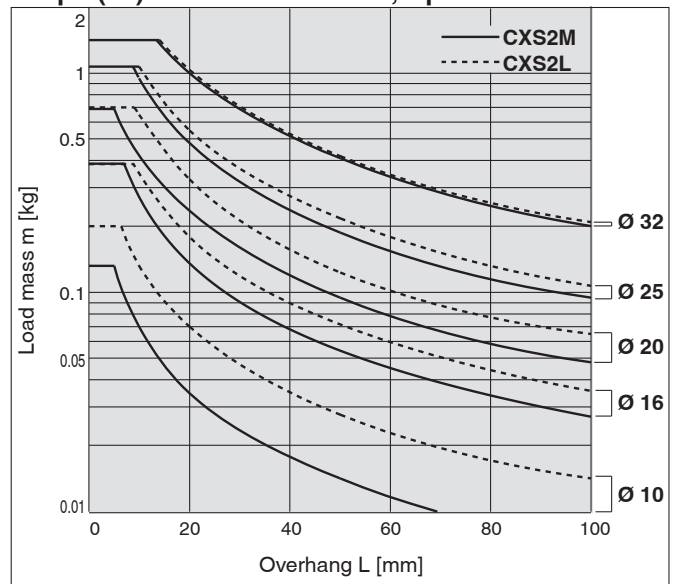

Horizontal Mounting

Ø 10 to Ø 32

Graph (18) V = Up to 400 mm/s; Up to 50 stroke

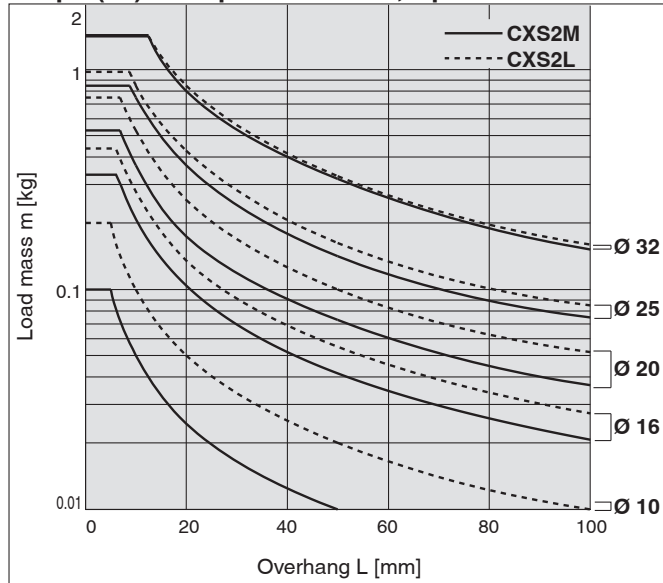

Graph (19) V = Over 400 mm/s; Up to 50 stroke

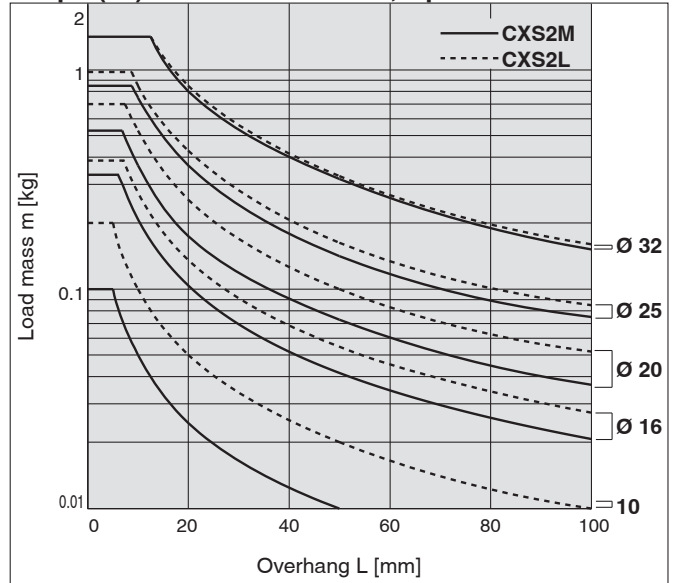

Graph (20) V = Over 400 mm/s; Up to 75 stroke

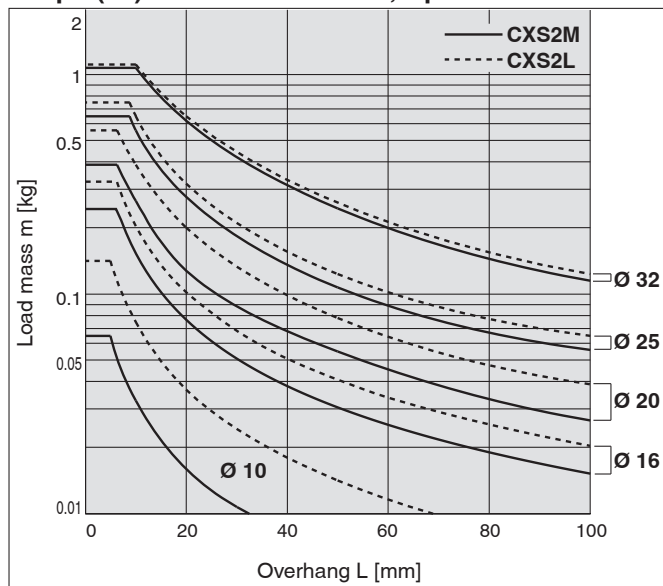

Graph (21) V = Over 400 mm/s; Up to 100 stroke

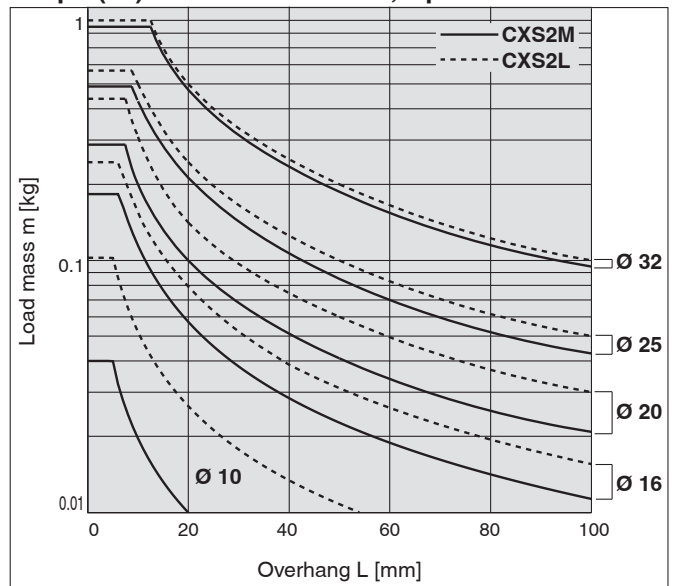

Dual Rod Cylinder

Basic Type

CXS2 Series

∅ 6, ∅ 10, ∅ 16, ∅ 20, ∅ 25, ∅ 32

How to Order

CXS2 **M** **20** **—** **100** **—** **M9BW** **—**

Bearing type

M	Slide bearing
L	Ball bushing bearing

Bore size

6	6 mm
10	10 mm
16	16 mm
20	20 mm
25	25 mm
32	32 mm

Thread type

Symbol	Type	Bore size
—	M thread	∅ 6 to ∅ 20
	Rc1/8	
TN	NPT1/8	∅ 25, ∅ 32
TF	G1/8	

Number of auto switches

—	2
S	1
n	n

Auto switch

—	Without auto switch (Built-in magnet)
---	---------------------------------------

* For applicable auto switches, refer to the table below.

Cylinder stroke [mm]

* Refer to page 12 for standard strokes.

Applicable Auto Switches/Refer to the Catalogue on www.smc.eu for further information on auto switches.

Type	Special function	Electrical entry	Indicator light	Wiring (Output)	Load voltage		Auto switch model		Lead wire length [m]*3				Pre-wired connector	Applicable load			
					DC	AC	Perpendicular	In-line	0.5 (—)	1 (M)	3 (L)	5 (Z)		IC circuit	Relay, PLC		
																—	—
Solid state auto switch	—	Grommet	Yes	3-wire (NPN)	5 V, 12 V	—	M9NV	M9N	●	●	●	○	○	IC circuit	Relay, PLC		
				3-wire (PNP)			M9PV	M9P	●	●	●	○	○				
				2-wire			M9BV	M9B	●	●	●	○	○				
	Diagnostic indication (2-colour indicator)			3-wire (NPN)	5 V, 12 V		M9NVV	M9NV	●	●	●	○	○	IC circuit			
				3-wire (PNP)			M9PVV	M9PV	●	●	●	○	○				
				2-wire			M9BVV	M9BV	●	●	●	○	○				
	Water resistant (2-colour indicator)			3-wire (NPN)	5 V, 12 V		M9NAV *1	M9NA *1	○	○	●	○	○	IC circuit			
				3-wire (PNP)			M9PAV *1	M9PA *1	○	○	●	○	○				
				2-wire			M9BAV *1	M9BA *1	○	○	●	○	○				
Reed auto switch	—	Grommet	Yes	3-wire (NPN)	24 V	5 V	100 V	—	A96V	A96	●	—	●	—	—	IC circuit	—
				2-wire					A93V *2	A93	●	●	●	●	—	—	Relay, PLC
				None					A90V	A90	●	—	●	—	—	—	IC circuit

*1 Water-resistant type auto switches can be mounted on the above models, but SMC cannot guarantee water resistance.

Please contact SMC regarding water-resistant types with the above model numbers.

*2 The 1 m lead wire is only applicable to the D-A93.

*3 Lead wire length symbols: 0.5 m — (Example) M9NV
 1 m M M9NVW
 3 m L M9NWL
 5 m Z M9NVZ

* Solid state auto switches marked with a "○" are produced upon receipt of order.

• Since there are applicable auto switches other than those listed above, refer to page 19 for details.

• For details on auto switches with pre-wired connectors, refer to the Catalogue on www.smc.eu.

* Auto switches are shipped together with the product but do not come assembled.



Specifications

Bore size [mm]	6	10	16	20	25	32
Fluid	Air (Non-lube)					
Proof pressure	1.05 MPa					
Max. operating pressure	0.7 MPa					
Min. operating pressure	0.15 MPa	0.1 MPa		0.05 MPa		
Ambient and fluid temperatures	-10 to 60 °C (No freezing)					
Piston speed	30 to 800 mm/s		30 to 700 mm/s		30 to 600 mm/s	
Cushion	Rubber bumper					
Stroke adjustable range	0 to -5 mm compared to the standard stroke					
Port size	M5 x 0.8				Rc (NPT, G) 1/8	
Bearing type	Slide bearing, Ball bushing bearing (Same dimensions for both)					
Allowable kinetic energy	0.016 J	0.064 J	0.095 J	0.17 J	0.27 J	0.32 J

Standard Stroke Range

Model	Stroke range	Standard stroke
CXS2□6	1 to 100	10, 20, 30, 40, 50, 60, 70, 75, 80, 90, 100
CXS2□10	1 to 150	10, 15, 20, 25, 30, 35, 40, 45, 50, 60, 70, 75, 80, 90, 100, 110, 120, 125, 150
CXS2□16	1 to 200	10, 15, 20, 25, 30, 35, 40, 45, 50, 60, 70, 75, 80, 90, 100, 110, 120, 125, 150, 175, 200
CXS2□20		10, 15, 20, 25, 30, 35, 40, 45, 50, 60, 70, 75, 80, 90, 100, 110, 120, 125, 150, 175, 200
CXS2□25		10, 15, 20, 25, 30, 35, 40, 45, 50, 60, 70, 75, 80, 90, 100, 110, 120, 125, 150, 175, 200
CXS2□32		10, 15, 20, 25, 30, 35, 40, 45, 50, 60, 70, 75, 80, 90, 100, 110, 120, 125, 150, 175, 200

* Intermediate strokes are available as special orders.

Refer to page 19 for cylinders with auto switches.

- Auto Switch Proper Mounting Position (Detection at stroke end)
- Operating Range
- Auto Switch Mounting Dimensions
- Auto Switch Mounting

Moisture Control Tube IDK Series



When operating an actuator with a small bore size and a short stroke at a high frequency, dew condensation (water droplets) may occur inside the piping depending on the conditions. Simply connecting the moisture control tube to the actuator will prevent dew condensation from occurring. For details, refer to the Catalogue on www.smc.eu.

Theoretical Output

Model	Rod size [mm]	Operating direction	Piston area [mm ²]	Operating pressure [MPa]							
				0.1	0.15	0.2	0.3	0.4	0.5	0.6	0.7
CXS2□6	4	OUT	56	—	8.4	11.2	16.8	22.4	28.0	33.6	39.2
		IN	31	—	4.6	6.2	9.3	12.4	15.5	18.6	21.7
CXS2□10	6	OUT	157	15.7	—	31.4	47.1	62.8	78.5	94.2	110
		IN	100	10.0	—	20.0	30.0	40.0	50.0	60.0	70.0
CXS2□16	8	OUT	402	40.2	—	80.4	121	161	201	241	281
		IN	301	30.1	—	60.2	90.3	120	151	181	211
CXS2□20	10	OUT	628	62.8	—	126	188	251	314	377	440
		IN	471	47.1	—	94.2	141	188	236	283	330
CXS2□25	12	OUT	982	98.2	—	196	295	393	491	589	687
		IN	756	75.6	—	151	227	302	378	454	529
CXS2□32	16	OUT	1608	161	—	322	482	643	804	965	1126
		IN	1206	121	—	241	362	482	603	724	844

* Theoretical output [N] = Pressure [MPa] x Piston area [mm²]

Weight

Model	Stroke range [mm]																				
	10	15	20	25	30	35	40	45	50	60	70	75	80	90	100	110	120	125	150	175	200
CXS2M6	0.08	—	0.10	—	0.11	—	0.12	—	0.14	0.15	0.17	0.17	0.18	0.19	0.21	—	—	—	—	—	—
CXS2L6	0.08	—	0.10	—	0.11	—	0.12	—	0.14	0.15	0.17	0.17	0.18	0.19	0.21	—	—	—	—	—	—
CXS2M10	0.14	0.15	0.16	0.17	0.18	0.19	0.20	0.21	0.22	0.24	0.26	0.27	0.28	0.30	0.32	0.34	0.36	0.37	0.42	—	—
CXS2L10	0.14	0.15	0.16	0.17	0.18	0.19	0.20	0.21	0.22	0.24	0.26	0.27	0.28	0.30	0.32	0.34	0.36	0.37	0.42	—	—
CXS2M16	0.24	0.26	0.27	0.28	0.30	0.31	0.32	0.34	0.35	0.38	0.40	0.42	0.43	0.45	0.48	0.51	0.53	0.55	0.61	0.68	0.75
CXS2L16	0.26	0.27	0.29	0.30	0.31	0.33	0.34	0.35	0.37	0.39	0.42	0.43	0.45	0.47	0.50	0.53	0.55	0.57	0.63	0.70	0.77
CXS2M20	0.40	0.41	0.43	0.45	0.47	0.49	0.50	0.52	0.54	0.58	0.61	0.63	0.65	0.69	0.72	0.76	0.79	0.81	0.90	0.99	1.09
CXS2L20	0.41	0.42	0.44	0.46	0.48	0.50	0.51	0.53	0.55	0.59	0.62	0.64	0.66	0.70	0.73	0.77	0.80	0.82	0.91	1.00	1.10
CXS2M25	0.59	0.62	0.65	0.67	0.70	0.72	0.75	0.78	0.80	0.86	0.91	0.94	0.96	1.02	1.07	1.12	1.17	1.20	1.33	1.47	1.60
CXS2L25	0.60	0.63	0.66	0.68	0.71	0.73	0.76	0.79	0.81	0.87	0.92	0.95	0.97	1.03	1.08	1.13	1.18	1.21	1.34	1.48	1.61
CXS2M32	1.09	1.13	1.18	1.22	1.26	1.30	1.34	1.38	1.43	1.51	1.59	1.64	1.68	1.76	1.84	1.93	2.01	2.05	2.26	2.47	2.68
CXS2L32	1.11	1.15	1.19	1.23	1.28	1.32	1.36	1.40	1.44	1.53	1.61	1.65	1.69	1.78	1.86	1.94	2.03	2.07	2.28	2.49	2.69

CXS2 Series

Operating Conditions

Non-rotating Accuracy

Non-rotating accuracy θ° at the retracted end and without a load should be less than or equal to the value provided in the table below as a guide.

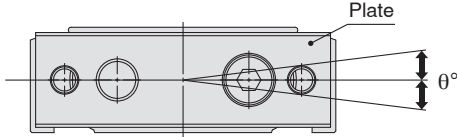

Bore size [mm]	$\text{O} 6$ to $\text{O} 32$
CXS2M (Slide bearing)	$\pm 0.1^\circ$
CXS2L (Ball bushing bearing)	

CXS2 \square 6 to 32 Deflection at the Plate End

An approximate plate-end deflection X without a load is shown in the graph below.

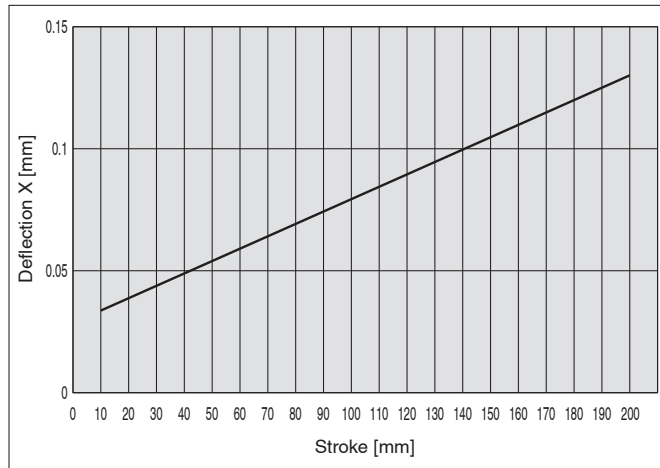
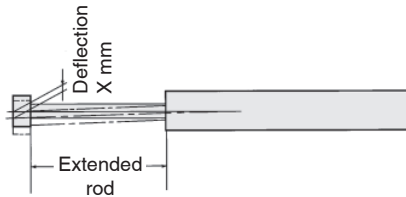

As a guide, $\text{O} 6$ is up to 100 mm strokes, $\text{O} 10$ is up to 150 mm strokes, and $\text{O} 16$ to $\text{O} 32$ are up to 200 mm strokes.

Max. Load Mass

When the cylinder is mounted as shown in the diagrams below, the max. load mass W should not exceed the values illustrated in the graph.

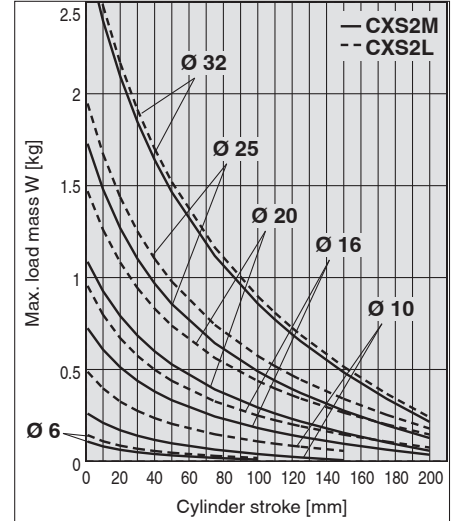
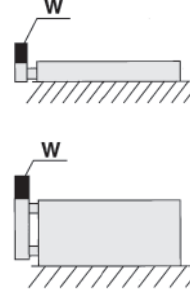

Construction: Slide Bearing

CXS2M6

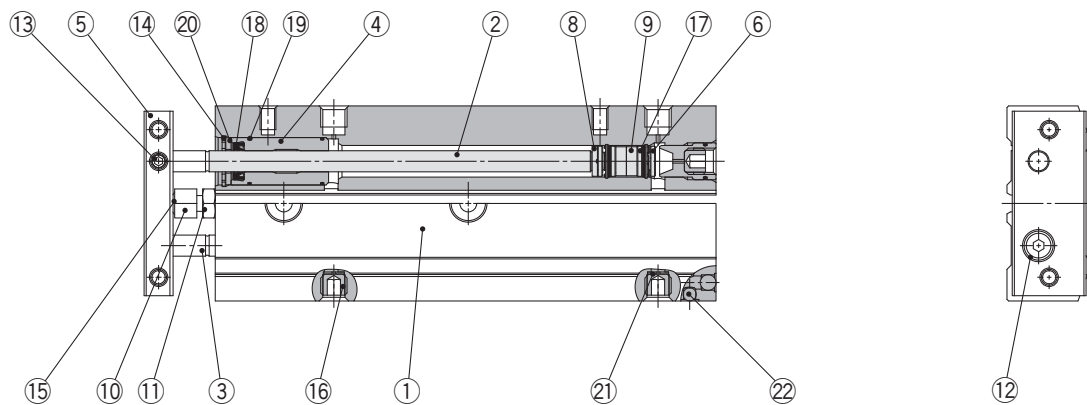

CXS2M10 to 32

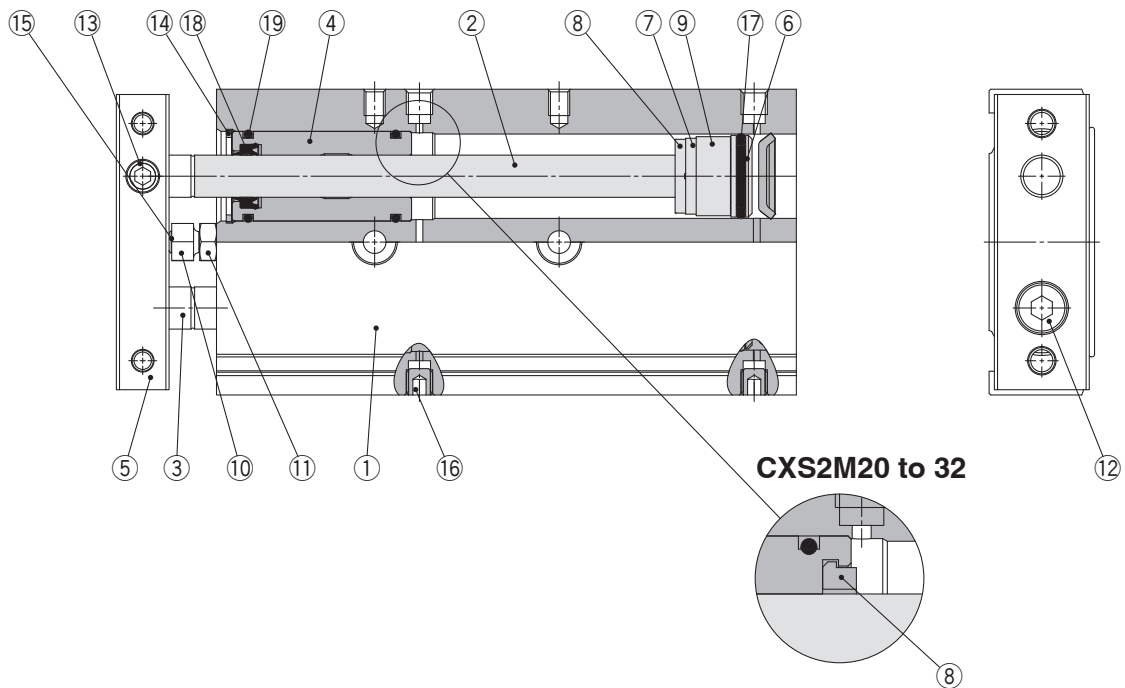

Component Parts

No.	Description	Material	Note
1	Housing	Aluminium alloy	Hard anodized
2	Piston rod A	Carbon steel*1	Hard chrome plating
3	Piston rod B	Carbon steel*1	Hard chrome plating
4	Rod cover	Aluminium bearing alloy	
5	Plate	Aluminium alloy	Anodized
6	Piston A	Aluminium alloy	
7	Piston B	Aluminium alloy	
8	Bumper	Urethane	
9	Magnet	—	
10	Bumper bolt	Carbon steel	Zinc chromated
11	Hexagon nut	Carbon steel	Zinc chromated
12	Hexagon socket head cap screw	Chromium steel	Zinc chromated
13	Hexagon socket head set screw	Chromium steel	Zinc chromated
14	Retaining ring	Special steel	Phosphate coating

*1 Stainless steel for CXSM6

Component Parts

No.	Description	Material	Note
15	Bumper	Urethane	
16	Plug	Chromium steel	Zinc chromated
17	Piston seal	NBR	
18	Rod seal	NBR	
19	O-ring	NBR	
20	Seal retainer	Aluminium alloy	
21	Port spacer	Aluminium alloy	
22	Steel ball	Special steel	Hard chrome plating

Replacement Parts: Seal Kit

Bore size [mm]	Part no.	Contents
6	CXS2M6-PS	Set of nos. above (17, 18 and 19)
10	CXS2M10APS	
16	CXS2M16-PS	
20	CXS2M20-PS	
25	CXS2M25-PS	
32	CXS2M32-PS	

* Seal kit includes 17, 18 and 19. Order the seal kit, based on each bore size.

* Since the seal kit does not include a grease pack, order it separately.

Grease pack part no.: GR-S-010 (10 g)

CXS2 Series

Construction: Ball Bushing Bearing

CXS2L6

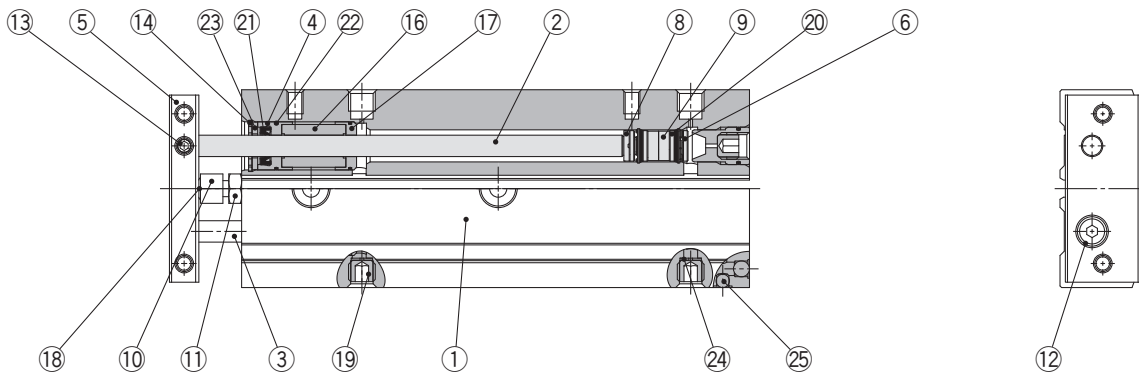

CXS2L10 to 32

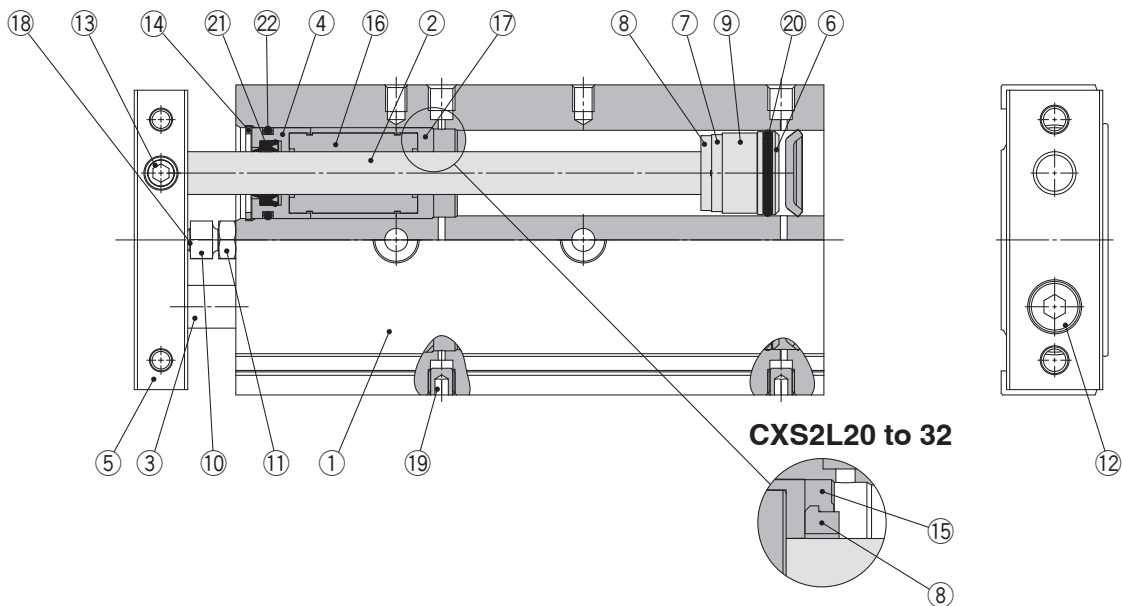

Component Parts: Standard Piping

No.	Description	Material	Note
1	Housing	Aluminium alloy	Hard anodized
2	Piston rod A	Special steel	Hard chrome plating
3	Piston rod B	Special steel	Hard chrome plating
4	Rod cover	Aluminium bearing alloy	
5	Plate	Aluminium alloy	Anodized
6	Piston A	Aluminium alloy	
7	Piston B	Aluminium alloy	
8	Bumper	Urethane	
9	Magnet	—	
10	Bumper bolt	Carbon steel	Zinc chromated
11	Hexagon nut	Carbon steel	Zinc chromated
12	Hexagon socket head cap screw	Chromium steel	Zinc chromated
13	Hexagon socket head set screw	Chromium steel	Zinc chromated
14	Retaining ring	Special steel	Phosphate coating
15	Bumper holder	Ø 20 to Ø 32: Synthetic resin	
16	Ball bushing	—	

Component Parts

No.	Description	Material	Note
17	Bearing spacer	Ø 10: Synthetic resin Ø 6, Ø 16: Aluminium bearing alloy	
18	Bumper	Urethane	
19	Plug	Chromium steel	Zinc chromated
20	Piston seal	NBR	
21	Rod seal	NBR	
22	O-ring	NBR	
23	Seal retainer	Aluminium alloy	
24	Port spacer	Aluminium alloy	
25	Steel ball	Special steel	Hard chrome plating

Replacement Parts: Seal Kit

Bore size [mm]	Part no.	Contents
6	CXS2L6-PS	Set of nos. above ⑳, ㉑ and ㉒
10	CXS2L10BPS	
16	CXS2L16-PS	
20	CXS2L20-PS	
25	CXS2L25-PS	
32	CXS2L32-PS	

* Seal kit includes ㉑, ㉑ and ㉒. Order the seal kit, based on each bore size.

* Since the seal kit does not include a grease pack, order it separately.

Grease pack part no.: GR-S-010 (10 g)

Dimensions: $\varnothing 6$

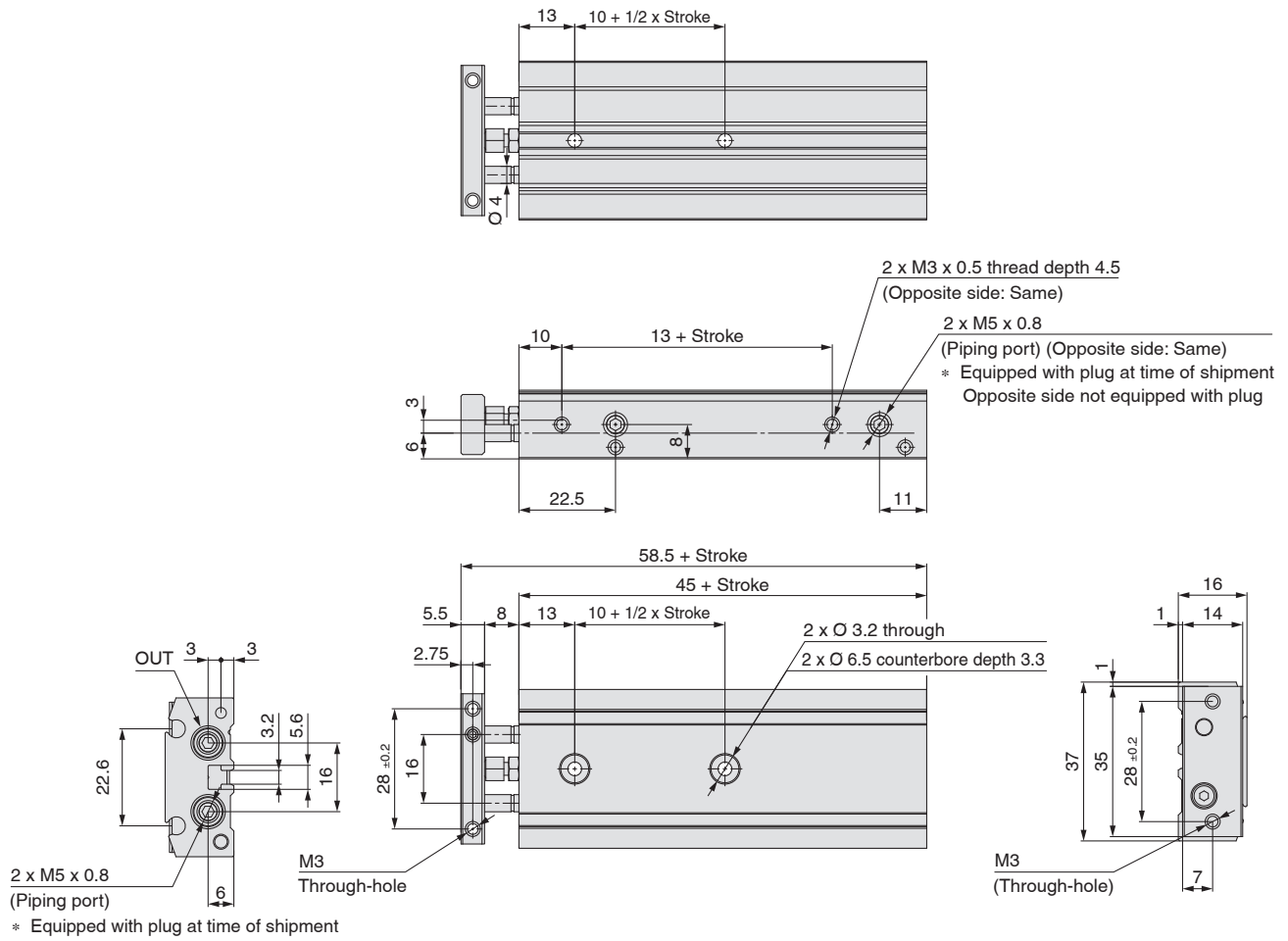

CXS2 Series

Dimensions: $\varnothing 10$, $\varnothing 16$

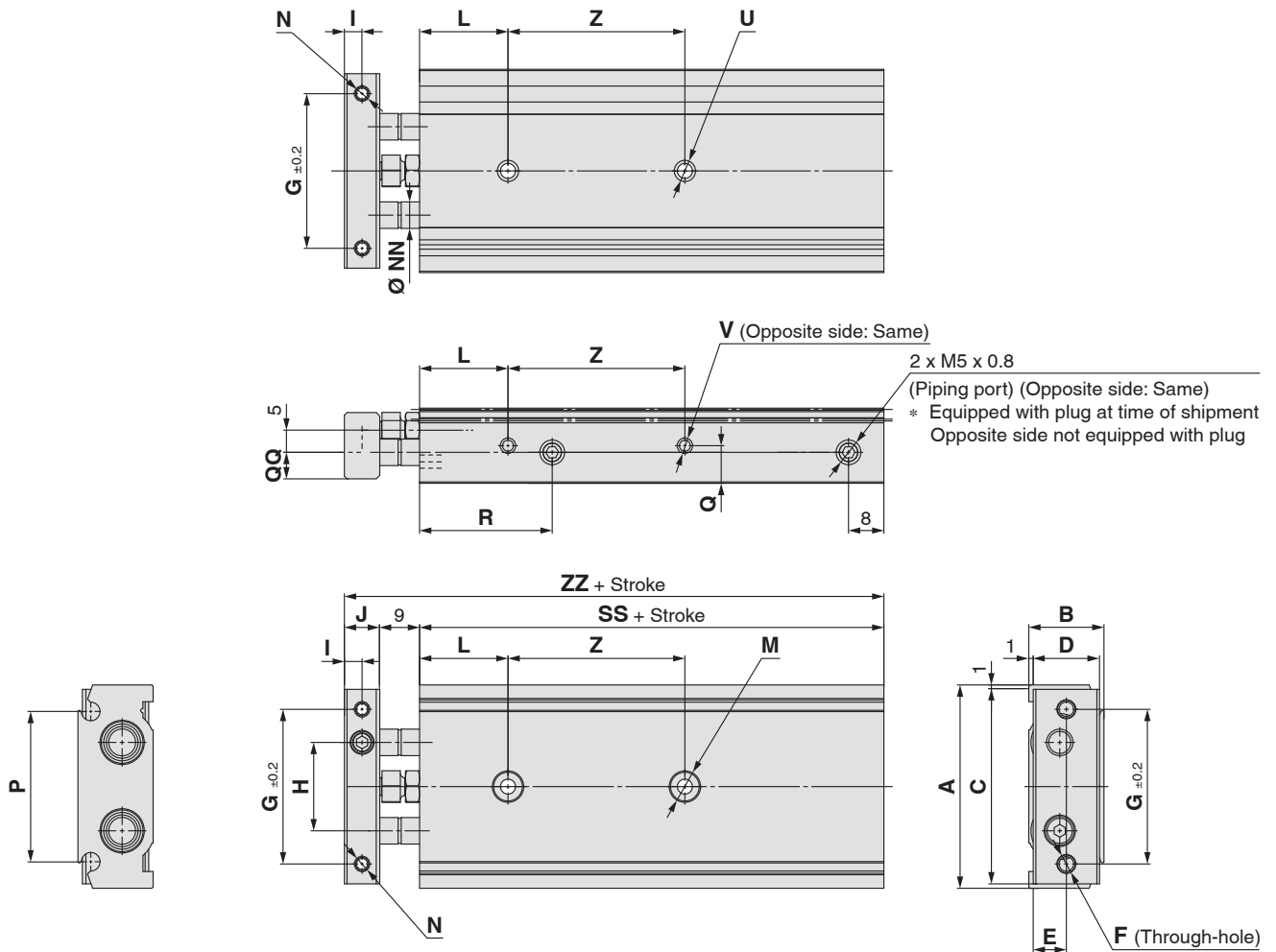

Model	A	B	C	D	E	F	G	H	I	J	L	M	N	NN	P	Q	QQ	R	U	V
CXS2□10	46	17	44	15	7.5	2 x M4 x 0.7	35	20	4	8	20	2 x $\varnothing 3.4$ through 2 x $\varnothing 6.5$ counterbore depth 3.3	2 x M3 x 0.5 thread depth 5	$\varnothing 6$	34	8.5	7	30	2 x M4 x 0.7 thread depth 7	4 x M3 x 0.5 thread depth 4.5
CXS2□16	58	20	56	18	9	2 x M5 x 0.8	45	25	5	10	30	2 x $\varnothing 4.3$ through 2 x $\varnothing 8$ counterbore depth 4.4	2 x M4 x 0.7 thread depth 6	$\varnothing 8$	45	10	10	38.5	2 x M5 x 0.8 thread depth 8	4 x M4 x 0.7 thread depth 5

Dimensions by Stroke

Model	Symbol Stroke	SS	Z							ZZ
			10, 15, 20, 25	30, 35, 40, 45, 50	60, 70, 75, 80	90, 100	110, 120, 125	150	175, 200	
CXS2□10		55	30	40	50	60	70	80	—	72
CXS2□16		60	25	35	45	55	65	75	145	79

Dimensions: $\varnothing 20$, $\varnothing 25$, $\varnothing 32$

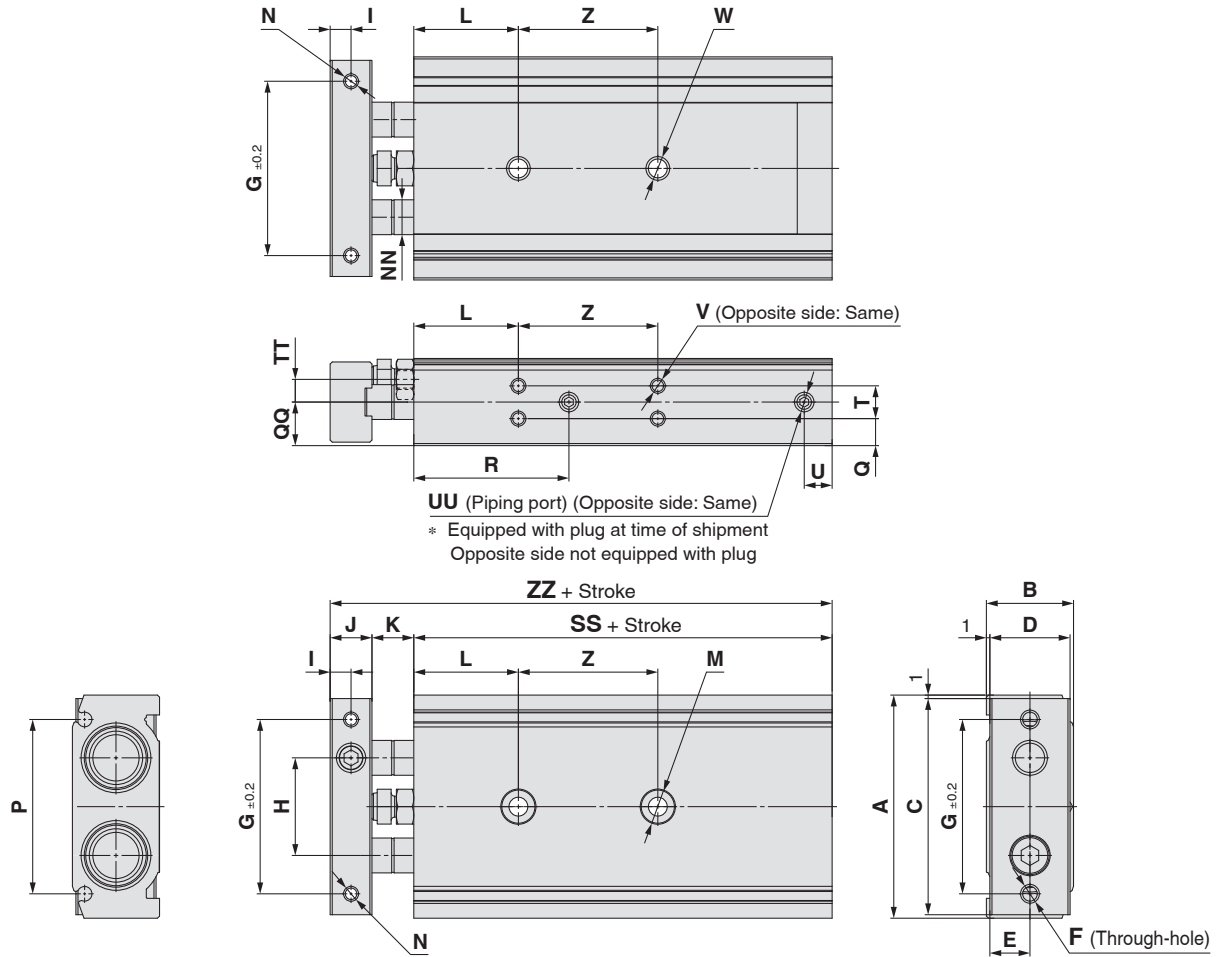

Model	A	B	C	D	E	F	G	H	I	J	K	L	M	N	NN	P
CXS2 \square 20	64	25	62	23	11.5	2 x M5 x 0.8	50	28	6	12	12	30	2 x $\varnothing 5.5$ through 2 x $\varnothing 9.5$ counterbore depth 5.3	2 x M4 x 0.7 thread depth 6	$\varnothing 10$	50
CXS2 \square 25	80	30	78	28	14	2 x M6 x 1.0	60	35	6	12	12	30	2 x $\varnothing 6.9$ through 2 x $\varnothing 11$ counterbore depth 6.3	2 x M5 x 0.8 thread depth 7.5	$\varnothing 12$	59.6
CXS2 \square 32	98	38	96	36	18	2 x M6 x 1.0	75	44	8	16	14	30	2 x $\varnothing 6.9$ through 2 x $\varnothing 11$ counterbore depth 6.3	2 x M5 x 0.8 thread depth 8	$\varnothing 16$	75

Model	Q	QQ	R	T	TT	U	UU			V	W
							—	TN	TF		
CXS2 \square 20	7.75	12.5	45	9.5	6.5	8	4 x M5 x 0.8	—	—	8 x M4 x 0.7 thread depth 5.5	2 x M6 x 1.0 thread depth 10
CXS2 \square 25	8.5	15	46	13	9	9	4 x Rc1/8	4 x NPT1/8	4 x G1/8	8 x M5 x 0.8 thread depth 7.5	2 x M8 x 1.25 thread depth 12
CXS2 \square 32	9	19	56	20	11.5	10				8 x M5 x 0.8 thread depth 7.5	2 x M8 x 1.25 thread depth 12

Dimensions by Stroke

Model	SS	Z					ZZ
		10, 15, 20, 25	30, 35, 40, 45, 50	60, 70, 75, 80, 90, 100	110, 120, 125, 150	175, 200	
CXS2 \square 20	70	30	40	60	80	100	94
CXS2 \square 25	72	30	40	60	80	100	96
CXS2 \square 32	82	40	50	70	90	110	112

CXS2 Series

Auto Switch Mounting

Auto Switch Proper Mounting Position (Detection at Stroke End)

Electrical entry direction: Inward

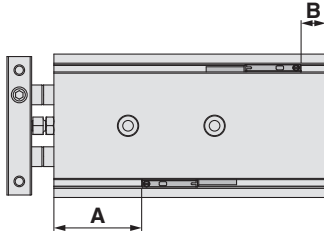

Electrical entry direction: Outward

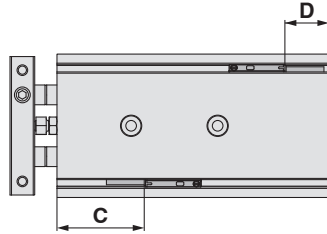

Operating Range

Auto switch model	Bore size [mm]					
	6	10	16	20	25	32
D-A9□, D-A9□V	6.5	5.5	5.5	7	7.5	9
D-M9□, D-M9□V D-M9□A, D-M9□AV D-M9□W, D-M9□WV	2.5	3	3.5	4.5	4.5	5

* Since this is a guideline including hysteresis, not meant to be guaranteed (assuming approx. ±30 % dispersion). There may be the case it will vary substantially depending on an ambient environment.

Bore size [mm]	D-A93				D-A90, D-A96 D-A9□V				D-M9□(E), D-M9□W D-M9□AV				D-M9□(E)V, D-M9□WV				D-M9□A			
	A	B	C	D	A	B	C	D	A	B	C	D	A	B	C	D	A	B	C	D
6	17	8	12.5	3.5	17	8	15	6	21	12	11	2	21	12	13	4	21	12	9	0
10	25	10	20.5	5.5	25	10	23	8	29	14	19	4	29	14	21	6	29	14	17	2
16	34	5.5	29.5	1	34	5.5	32	3.5	38	9.5	28	-0.5	38	9.5	30	1.5	38	9.5	26	-2.5
20	40	10	35.5	5.5	40	10	38	8	44	14	34	4	44	14	36	6	44	14	32	2
25	41	11	36.5	6.5	41	11	39	9	45	15	35	5	45	15	37	7	45	15	33	3
32	50	11.5	45.5	7	50	11.5	48	9.5	54	15.5	44	5.5	54	15.5	46	7.5	54	15.5	42	3.5

* Negative figures in the column D indicate how much the load wires protrude from the cylinder body.
* Adjust the auto switch after confirming the operating conditions in the actual setting.

Dimensions for Auto Switch Mounting

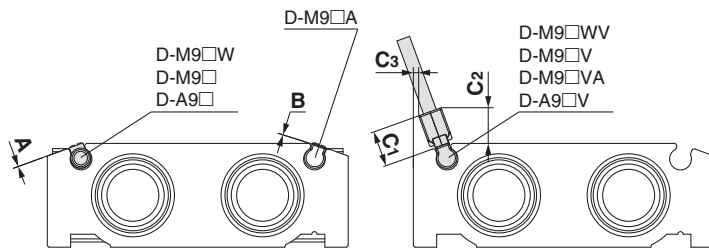

A Dimension

Symbol	Bore size [mm]					
	6	10	16	20	25	32
D-M9□, D-M9□W D-A9□	A	0.5	0.5	0.5	0.5	0.5
D-M9□A	B	1	1	1	1	1
D-M9□V, D-M9□WV	C1	7.5	7	7.5	7.5	7.5
D-M9□AV	C2	7.5	6	7.5	7.5	6.5
D-A9□V	C3	—	2.5	—	—	—

How to Mount Auto Switches

When mounting and securing auto switches, they should be inserted into the cylinder's auto switch mounting rail from the direction shown in the drawing below. After setting in the mounting position, use a flat head watchmaker's screwdriver to tighten the auto switch mounting screw that is included.

* When tightening an auto switch mounting screw, use a watchmaker's screwdriver with a handle of approx. 5 to 6 mm in diameter.

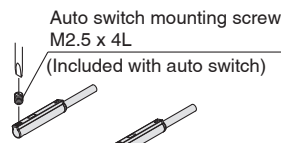

Tightening Torque for Auto Switch Mounting Screw [N·m]

Auto switch model	Tightening torque
D-A9□(V) (Excludes the D-A93)	0.10 to 0.20
D-M9□(V) D-M9□W(V) D-M9□A(V) D-A93	0.05 to 0.15

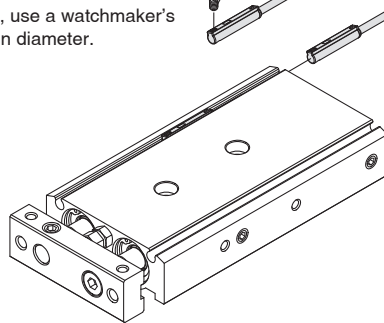

Caution

1. Avoid proximity to magnetic objects

When the body of the cylinder fitted with auto switches is adjacent to a magnetic substance such as a ferrous metal plate, it is necessary to ensure that there is at least 10 mm between the cylinder's upper surface and the magnetic substance as shown in the figure below. Failure to provide adequate clearance may cause the auto switch to malfunction (switch does not turn on).

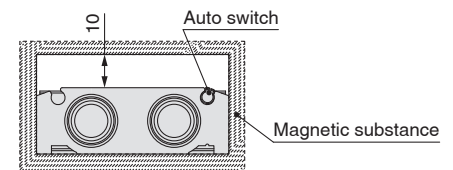

Other than the applicable auto switches listed in "How to Order," the following auto switches are also mountable. Refer to the Catalogue on www.smc.eu for detailed specifications.

* Normally closed (NC = b contact) solid state auto switches (D-M9□E(V)) are also available. For details, refer to the Catalogue on www.smc.eu.

Prior to Use

Auto Switch Connections and Examples

Sink Input Specifications

3-wire, NPN

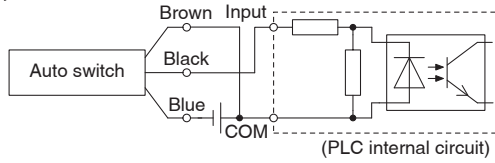

2-wire

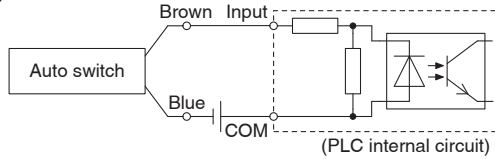

Source Input Specifications

3-wire, PNP

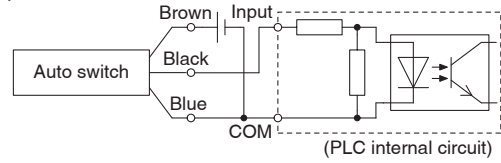

2-wire

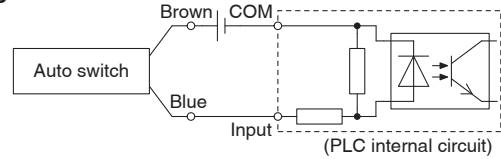

Connect according to the applicable PLC input specifications, as the connection method will vary depending on the PLC input specifications.

Examples of AND (Series) and OR (Parallel) Connections

* When using solid state auto switches, ensure the application is set up so the signals for the first 50 ms are invalid. Depending on the operating environment, the product may not operate properly.

3-wire AND connection for NPN output (Using relays)

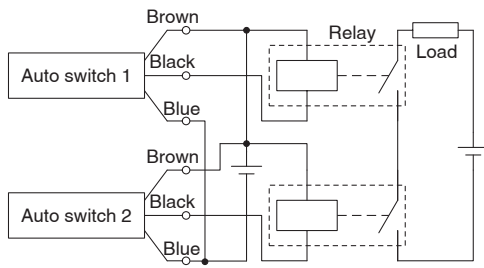

(Performed with auto switches only)

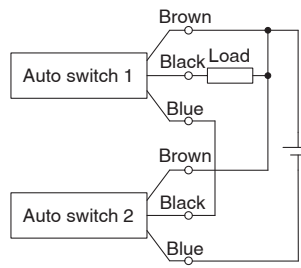

3-wire OR connection for NPN output

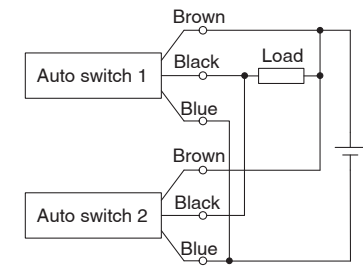

3-wire AND connection for PNP output (Using relays)

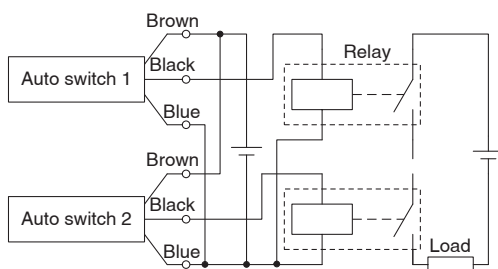

(Performed with auto switches only)

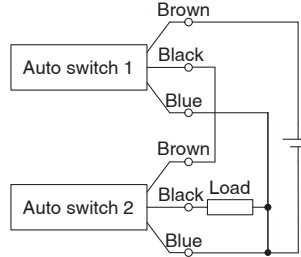

3-wire OR connection for PNP output

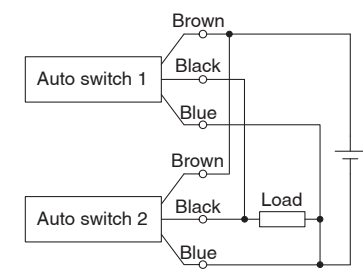

2-wire AND connection

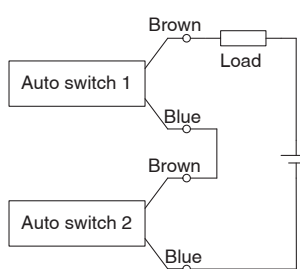

When two auto switches are connected in series, a load may malfunction because the load voltage will decline when in the ON state. The indicator lights will light up when both of the auto switches are in the ON state. Auto switches with a load voltage less than 20 V cannot be used. Please contact SMC if using AND connection for a heat-resistant solid state auto switch or a trimmer switch.

Example) Load voltage at ON
 Power supply voltage: 24 VDC
 Internal voltage drop: 4 V
 Load voltage at ON = Power supply voltage –
 Internal voltage drop x 2 pcs.
 = 24 V – 4 V x 2 pcs.
 = 16 V

2-wire OR connection

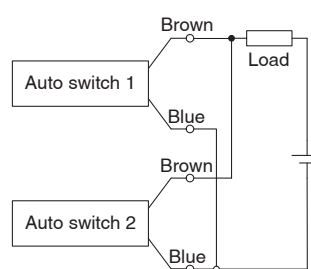

(Solid state)
 When two auto switches are connected in parallel, malfunction may occur because the load voltage will increase when in the OFF state.

(Reed)
 Because there is no current leakage, the load voltage will not increase when turned OFF. However, depending on the number of auto switches in the ON state, the indicator lights may sometimes grow dim or not light up, due to the dispersion and reduction of the current flowing to the auto switches.

Example) Load voltage at OFF
 Leakage current: 1 mA
 Load impedance: 3 kΩ
 Load voltage at OFF = Leakage current x 2 pcs. x
 Load impedance
 = 1 mA x 2 pcs. x 3 kΩ
 = 6 V



CXS2 Series Specific Product Precautions

Be sure to read this before handling the products. Refer to the back cover for safety instructions. For actuator and auto switch precautions, refer to the “Handling Precautions for SMC Products” and the “Operation Manual” on the SMC website: <https://www.smc.eu>

Mounting

⚠ Caution

1. **Make sure that the surface on which the cylinder is to be mounted is flat (reference value for flatness: 0.05 or less).**

Dual rod cylinders can be mounted from 3 directions, however, make sure that the surface on which the cylinder is to be mounted is flat (reference value for flatness: 0.05 or less). Otherwise, the accuracy of the piston rod operation is not achieved, and malfunctioning can occur.

2. **Piston rod must be retracted when mounting the cylinder.**

Scratches or gouges in the piston rod may lead to damaged bearings and/or seals and cause a malfunction or air leakage.

Piping

⚠ Caution

1. **Plug the appropriate supply port(s) according to the operating conditions.**

Dual rod cylinders have 2 supply ports for each operating direction (3 supply ports for \varnothing 6 only). Plug the appropriate supply port according to the operating conditions. However, when switching the plugged port, verify air leakage. If small air leakage is detected, order the below plugs, and reassemble it.

Plug part no.: (\varnothing 6) CXS10-08-28747B
 (\varnothing 10 to \varnothing 20) CXS20-08-28749A
 (\varnothing 25 to \varnothing 32) CYP025-08B29449A (Rc 1/8)
 CXS25-08-A3025B (NPT 1/8)
 CXS25-08-A3911A (G 1/8)

Stroke Adjustment

⚠ Caution

1. **After adjusting the stroke, make sure to tighten the hexagon nut to prevent it from loosening.**

Dual rod cylinders have a bolt to adjust 0 to -5 mm strokes on the retracted end (IN).

Loosen the hexagon nut to adjust the stroke; however, make sure to tighten the hexagon nut after making an adjustment.

2. **Never operate a cylinder with its bumper bolt removed. Also, do not attempt to tighten the bumper bolt without using a nut.**

If the bumper bolt is removed, the piston hits housing end surface causing damage to the cylinder. Therefore, do not use a cylinder without a bumper bolt.

Furthermore, if the bumper bolt is tightened without a nut, the piston seal is caught in the levelled part, damaging the seal.

Stroke Adjustment

⚠ Caution

3. **The bumper located at the end of the bumper bolts**

If the bumper has permanently settled onto the product or if it is lost, an order can be placed by using the part numbers listed below.

Bore size [mm]	6, 10, 15	20, 25	32
Part no.	CXS10-34A 28747	CXS20-34A 28749	CXS32-34A 28751
Qty.	1		

Disassembly and Maintenance

⚠ Caution

1. **Never use a cylinder with its plate removed.**

When removing the hexagon socket head cap screw on the end plate, the piston rod must be secured to prevent from rotating. However, if the sliding parts of the piston rod are scratched and gouged, a malfunction may occur.

2. **When disassembling and reassembling the cylinder, please contact SMC or refer to the separate operation manual.**

⚠ Warning

1. **Take precautions when your hands are near the plate and housing.**

Take sufficient care to avoid getting your hands or fingers caught when the cylinder is operated.

Operating Environment

⚠ Caution

1. **Do not operate the cylinder in a pressurised environment.**

The pressurised air may flow inside the cylinder due to its construction.

2. **Do not use as a stopper. This may cause a malfunction. When using as a stopper, select a stopper cylinder (RS series) or a compact guide cylinder (MGP series).**

Speed Adjustment



⚠ Caution

1. **A sudden extension may occur with CXS2□6.**

CXS2□6 has a low internal volume and sudden extension/erratic movement may occur particularly when it is used at low speed. This sudden extension can be mitigated by combining the use of meter-in and meter-out speed controllers.

Safety Instructions

These safety instructions are intended to prevent hazardous situations and/or equipment damage. These instructions indicate the level of potential hazard with the labels of “Caution,” “Warning” or “Danger.” They are all important notes for safety and must be followed in addition to International Standards (ISO/IEC)¹⁾, and other safety regulations.

-  **Caution:** **Caution** indicates a hazard with a low level of risk which, if not avoided, could result in minor or moderate injury.
-  **Warning:** **Warning** indicates a hazard with a medium level of risk which, if not avoided, could result in death or serious injury.
-  **Danger:** **Danger** indicates a hazard with a high level of risk which, if not avoided, will result in death or serious injury.

- 1) ISO 4414: Pneumatic fluid power – General rules relating to systems.
ISO 4413: Hydraulic fluid power – General rules relating to systems.
IEC 60204-1: Safety of machinery – Electrical equipment of machines.
(Part 1: General requirements)
ISO 10218-1: Manipulating industrial robots - Safety.
etc.

Warning

1. The compatibility of the product is the responsibility of the person who designs the equipment or decides its specifications.

Since the product specified here is used under various operating conditions, its compatibility with specific equipment must be decided by the person who designs the equipment or decides its specifications based on necessary analysis and test results. The expected performance and safety assurance of the equipment will be the responsibility of the person who has determined its compatibility with the product. This person should also continuously review all specifications of the product referring to its latest catalogue information, with a view to giving due consideration to any possibility of equipment failure when configuring the equipment.

2. Only personnel with appropriate training should operate machinery and equipment.

The product specified here may become unsafe if handled incorrectly. The assembly, operation and maintenance of machines or equipment including our products must be performed by an operator who is appropriately trained and experienced.

3. Do not service or attempt to remove product and machinery/equipment until safety is confirmed.

1. The inspection and maintenance of machinery/equipment should only be performed after measures to prevent falling or runaway of the driven objects have been confirmed.
2. When the product is to be removed, confirm that the safety measures as mentioned above are implemented and the power from any appropriate source is cut, and read and understand the specific product precautions of all relevant products carefully.
3. Before machinery/equipment is restarted, take measures to prevent unexpected operation and malfunction.

4. Contact SMC beforehand and take special consideration of safety measures if the product is to be used in any of the following conditions.

1. Conditions and environments outside of the given specifications, or use outdoors or in a place exposed to direct sunlight.
2. Installation on equipment in conjunction with atomic energy, railways, air navigation, space, shipping, vehicles, military, medical treatment, combustion and recreation, or equipment in contact with food and beverages, emergency stop circuits, clutch and brake circuits in press applications, safety equipment or other applications unsuitable for the standard specifications described in the product catalogue.
3. An application which could have negative effects on people, property, or animals requiring special safety analysis.
4. Use in an interlock circuit, which requires the provision of double interlock for possible failure by using a mechanical protective function, and periodical checks to confirm proper operation.

Caution

1. The product is provided for use in manufacturing industries.

The product herein described is basically provided for peaceful use in manufacturing industries.
If considering using the product in other industries, consult SMC beforehand and exchange specifications or a contract if necessary.
If anything is unclear, contact your nearest sales branch.

Limited warranty and Disclaimer/Compliance Requirements

The product used is subject to the following “Limited warranty and Disclaimer” and “Compliance Requirements”. Read and accept them before using the product.

Limited warranty and Disclaimer

1. The warranty period of the product is 1 year in service or 1.5 years after the product is delivered, whichever is first.²⁾ Also, the product may have specified durability, running distance or replacement parts. Please consult your nearest sales branch.
 2. For any failure or damage reported within the warranty period which is clearly our responsibility, a replacement product or necessary parts will be provided. This limited warranty applies only to our product independently, and not to any other damage incurred due to the failure of the product.
 3. Prior to using SMC products, please read and understand the warranty terms and disclaimers noted in the specified catalogue for the particular products.
- 2) Vacuum pads are excluded from this 1 year warranty.
A vacuum pad is a consumable part, so it is warranted for a year after it is delivered. Also, even within the warranty period, the wear of a product due to the use of the vacuum pad or failure due to the deterioration of rubber material are not covered by the limited warranty.

Compliance Requirements

1. The use of SMC products with production equipment for the manufacture of weapons of mass destruction (WMD) or any other weapon is strictly prohibited.
2. The exports of SMC products or technology from one country to another are governed by the relevant security laws and regulations of the countries involved in the transaction. Prior to the shipment of a SMC product to another country, assure that all local rules governing that export are known and followed.

Caution

SMC products are not intended for use as instruments for legal metrology.

Measurement instruments that SMC manufactures or sells have not been qualified by type approval tests relevant to the metrology (measurement) laws of each country. Therefore, SMC products cannot be used for business or certification ordained by the metrology (measurement) laws of each country.

Safety Instructions

Be sure to read “Handling Precautions for SMC Products” (M-E03-3) before using.

SMC Corporation (Europe)

Austria	+43 (0)2262622800	www.smc.at	office@smc.at
Belgium	+32 (0)33551464	www.smc.be	info@smc.be
Bulgaria	+359 (0)2807670	www.smc.bg	office@smc.bg
Croatia	+385 (0)13707288	www.smc.hr	office@smc.hr
Czech Republic	+420 541424611	www.smc.cz	office@smc.cz
Denmark	+45 70252900	www.smc.dk.com	smc@smcdk.com
Estonia	+372 651 0370	www.smcee.ee	info@smcee.ee
Finland	+358 207513513	www.smc.fi	smcfi@smc.fi
France	+33 (0)164761000	www.smc-france.fr	supportclient@smc-france.fr
Germany	+49 (0)61034020	www.smc.de	info@smc.de
Greece	+30 210 2717265	www.smchellas.gr	sales@smchellas.gr
Hungary	+36 23513000	www.smc.hu	office@smc.hu
Ireland	+353 (0)14039000	www.smcautomation.ie	sales@smcautomation.ie
Italy	+39 03990691	www.smcitalia.it	mailbox@smcitalia.it
Latvia	+371 67817700	www.smc.lv	info@smc.lv

Lithuania	+370 5 2308118	www.smclt.lt	info@smclt.lt
Netherlands	+31 (0)205318888	www.smc.nl	info@smc.nl
Norway	+47 67129020	www.smc-norge.no	post@smc-norge.no
Poland	+48 222119600	www.smc.pl	office@smc.pl
Portugal	+351 214724500	www.smc.eu	apoioclientept@smc.smces.es
Romania	+40 213205111	www.smcromania.ro	smcromania@smcromania.ro
Russia	+7 (812)3036600	www.smc.eu	sales@smcru.com
Slovakia	+421 (0)413213212	www.smc.sk	office@smc.sk
Slovenia	+386 (0)73885412	www.smc.si	office@smc.si
Spain	+34 945184100	www.smc.eu	post@smc.smces.es
Sweden	+46 (0)86031240	www.smc.nu	smc@smc.nu
Switzerland	+41 (0)523963131	www.smc.ch	info@smc.ch
Turkey	+90 212 489 0 440	www.smcturkey.com.tr	info@smcturkey.com.tr
UK	+44 (0)845 121 5122	www.smc.uk	sales@smc.uk

South Africa +27 10 900 1233 www.smcza.co.za zasales@smcza.co.za