

# Longer Life Cylinder

*New technology offers at least 4 times better durability*

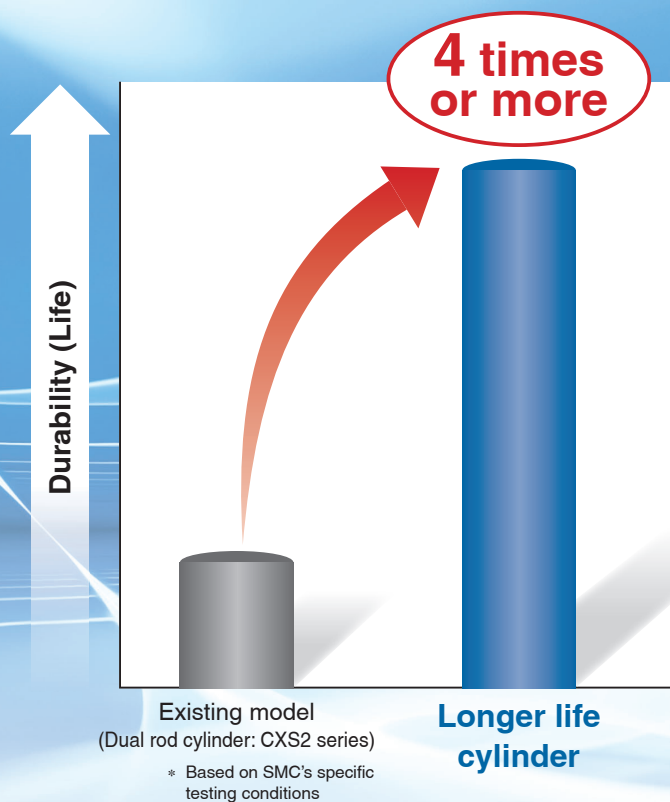

- The maintenance intervals will be extended



- Employs the same specification and dimensions as the existing models, CXS2 Dual Rod Cylinder series

**High Durability Series**

High Durability Series is the series name for the "special specification" that offers superior durability and environmental resistance compared to standard products.

## Series Variations

Series	Bearing type	Model	Bore size [mm]						Cushion	Standard stroke [mm]
			6	10	16	20	25	32		
Dual rod cylinder CXS2 series 	Slide bearing	CXS2M-XB24	●	●	●	●	●	●	Rubber bumper	O 6: 10 to 100 O 10: 10 to 150 O 16 to O 32: 10 to 200

**CXS2-XB24**



## High Durability Series

# Longer Life Cylinder

# CXS2-XB24

RoHS

∅ 6, ∅ 10, ∅ 16, ∅ 20, ∅ 25, ∅ 32

## How to Order

**CXS2 M 20** **100** **M9BW** **XB24**

**Bearing type**

M	Slide bearing
---	---------------

**Bore size**

6	6 mm
10	10 mm
16	16 mm
20	20 mm
25	25 mm
32	32 mm

**Thread type**

Symbol	Type	Bore size
—	M thread	∅ 6 to ∅ 20
	Rc1/8	
TN	NPT1/8	∅ 25, ∅ 32
TF	G1/8	

**Cylinder stroke [mm]**  
\* Refer to page 2 for standard strokes.

**Number of auto switches**

—	2
S	1
n	n

**Auto switch**

—	Without auto switch (Built-in magnet)
---	---------------------------------------

\* For applicable auto switches, refer to the table below.

## Applicable Auto Switches / Refer to the catalogue on [www.smc.eu](http://www.smc.eu) for further information on auto switches.

Type	Special function	Electrical entry	Indicator light	Wiring (Output)	Load voltage		Auto switch model		Lead wire length [m] <sup>*3</sup>				Pre-wired connector	Applicable load		
					DC	AC	Perpendicular	In-line	0.5 (—)	1 (M)	3 (L)	5 (Z)		IC circuit	Relay, PLC	
																5 V, 12 V
Solid state auto switch	—	Grommet	Yes	3-wire (NPN)	24 V	5 V, 12 V	—	M9NV	M9N	●	●	●	○	○	IC circuit	Relay, PLC
				3-wire (PNP)				M9PV	M9P	●	●	●	○	○		
				2-wire				M9BV	M9B	●	●	●	○	○		
	Diagnostic indication (2-colour indicator)			3-wire (NPN)	24 V	5 V, 12 V	—	M9NVV	M9NV	●	●	●	○	○	IC circuit	Relay, PLC
				3-wire (PNP)				M9PVV	M9PV	●	●	●	○	○		
				2-wire				M9BVV	M9BV	●	●	●	○	○		
	Water resistant (2-colour indicator)			3-wire (NPN)	24 V	5 V, 12 V	—	M9NAV <sup>*1</sup>	M9NA <sup>*1</sup>	○	○	●	○	○	IC circuit	Relay, PLC
				3-wire (PNP)				M9PAV <sup>*1</sup>	M9PA <sup>*1</sup>	○	○	●	○	○		
				2-wire				M9BAV <sup>*1</sup>	M9BA <sup>*1</sup>	○	○	●	○	○		
Reed auto switch	—	Grommet	Yes	3-wire (NPN)	24 V	5 V	—	A96V	A96	●	—	●	—	—	IC circuit	—
				2-wire		12 V	100 V	A93V <sup>*2</sup>	A93	●	●	●	●	—	—	Relay, PLC
				2-wire		5 V, 12 V	100 V or less	A90V	A90	●	—	●	—	—	IC circuit	—

\*1 Water-resistant type auto switches can be mounted on the above models, but SMC cannot guarantee water resistance.

Please contact SMC regarding water-resistant types with the above model numbers.

\*2 The 1 m lead wire is only applicable to the D-A93.

\*3 Lead wire length symbols: 0.5 m ..... — (Example) M9NW  
 1 m ..... M M9NWM  
 3 m ..... L M9NWL  
 5 m ..... Z M9NWZ

\* Solid state auto switches marked with a "○" are produced upon receipt of order.

• Since there are applicable auto switches other than those listed above, refer to the catalogue on [www.smc.eu](http://www.smc.eu) for details.

• For details on auto switches with pre-wired connectors, refer to the catalogue on [www.smc.eu](http://www.smc.eu).

\* Auto switches are shipped together with the product but do not come assembled.



## Specifications

Bore size [mm]	6	10	16	20	25	32
Fluid	Air (Non-lube)					
Proof pressure	1.05 MPa					
Max. operating pressure	0.7 MPa					
Min. operating pressure	0.15 MPa	0.1 MPa		0.05 MPa		
Ambient and fluid temperatures	-10 to 60 °C (No freezing)					
Piston speed	30 to 800 mm/s		30 to 700 mm/s		30 to 600 mm/s	
Cushion	Rubber bumper					
Stroke adjustable range	0 to -5 mm compared to the standard stroke					
Port size	M5 x 0.8				Rc (NPT, G) 1/8	
Bearing type	Slide bearing					
Allowable kinetic energy	0.016 J	0.064 J	0.095 J	0.17 J	0.27 J	0.32 J

## Standard Stroke Range

Model	Stroke range	Standard stroke
<b>CXS2M6</b>	1 to 100	10, 20, 30, 40, 50, 60, 70, 75, 80, 90, 100
<b>CXS2M10</b>	1 to 150	10, 15, 20, 25, 30, 35, 40, 45, 50, 60, 70, 75, 80, 90, 100, 110, 120, 125, 150
<b>CXS2M16</b>	1 to 200	10, 15, 20, 25, 30, 35, 40, 45, 50, 60, 70, 75, 80, 90, 100, 110, 120, 125, 150, 175, 200
<b>CXS2M20</b>		10, 15, 20, 25, 30, 35, 40, 45, 50, 60, 70, 75, 80, 90, 100, 110, 120, 125, 150, 175, 200
<b>CXS2M25</b>		10, 15, 20, 25, 30, 35, 40, 45, 50, 60, 70, 75, 80, 90, 100, 110, 120, 125, 150, 175, 200
<b>CXS2M32</b>		10, 15, 20, 25, 30, 35, 40, 45, 50, 60, 70, 75, 80, 90, 100, 110, 120, 125, 150, 175, 200

\* Intermediate strokes are available as special orders.

Refer to the **Catalogue** on [www.smc.eu](http://www.smc.eu) for cylinders with auto switches.

- Auto Switch Proper Mounting Position (Detection at stroke end)
- Operating Range
- Auto Switch Mounting Dimensions
- Auto Switch Mounting

### Moisture Control Tube IDK Series



When operating an actuator with a small bore size and a short stroke at a high frequency, dew condensation (water droplets) may occur inside the piping depending on the conditions. Simply connecting the moisture control tube to the actuator will prevent dew condensation from occurring. For details, refer to the **Catalogue** on [www.smc.eu](http://www.smc.eu).

## ⚠ Precautions

Refer to page 6 before handling.

The model selection, non-rotating accuracy, deflection at the plate end, max. load mass, allowable kinetic energy, allowable loads at the rod end, theoretical output, and weight are equivalent to those of the Dual Rod Cylinder CXS2 series. For details, refer to the **catalogue** on [www.smc.eu](http://www.smc.eu).

# CXS2-XB24

Dimensions:  $\varnothing 6$

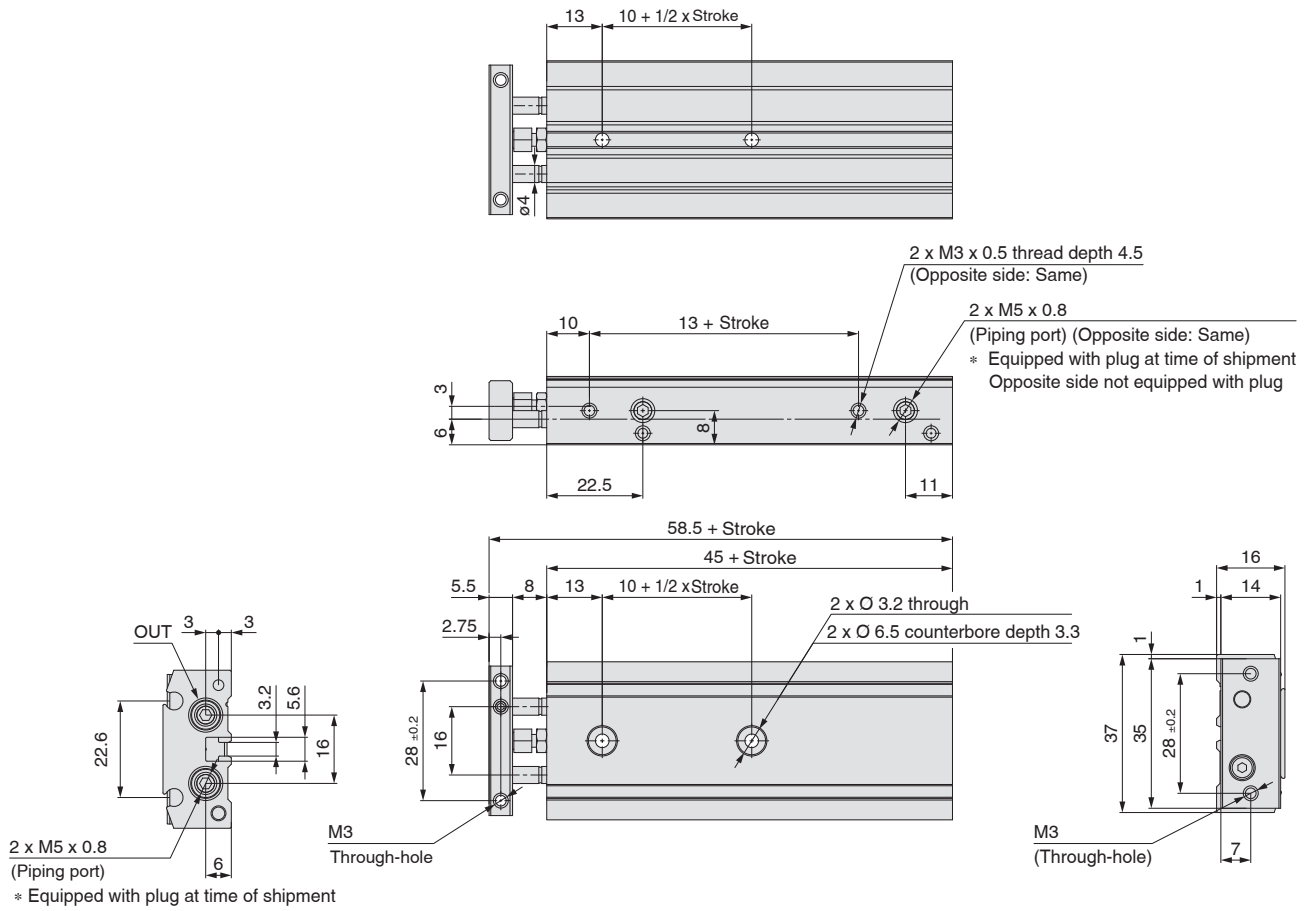

**Dimensions:  $\varnothing 10, \varnothing 16$**

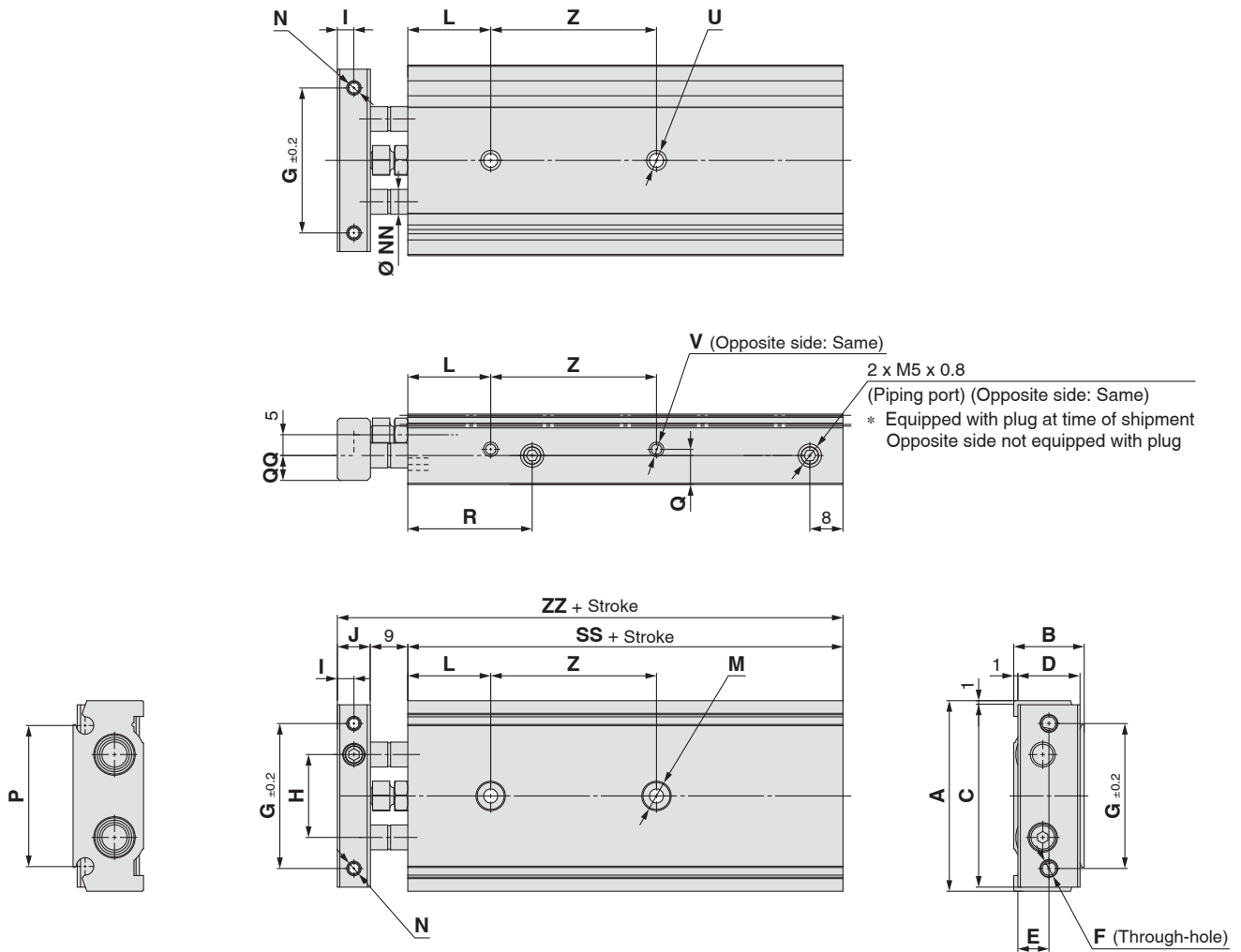

Model	A	B	C	D	E	F	G	H	I	J	L	M	N	NN	P	Q	QQ	R	U	V
<b>CXS2M10</b>	46	17	44	15	7.5	2 x M4 x 0.7	35	20	4	8	20	2 x $\varnothing 3.4$ through 2 x $\varnothing 6.5$ counterbore depth 3.3	2 x M3 x 0.5 thread depth 5	$\varnothing 6$	34	8.5	7	30	2 x M4 x 0.7 thread depth 7	4 x M3 x 0.5 thread depth 4.5
<b>CXS2M16</b>	58	20	56	18	9	2 x M5 x 0.8	45	25	5	10	30	2 x $\varnothing 4.3$ through 2 x $\varnothing 8$ counterbore depth 4.4	2 x M4 x 0.7 thread depth 6	$\varnothing 8$	45	10	10	38.5	2 x M5 x 0.8 thread depth 8	4 x M4 x 0.7 thread depth 5

**Dimensions by Stroke**

Model	Symbol Stroke	SS	Z							ZZ
			10, 15, 20, 25	30, 35, 40, 45, 50	60, 70, 75, 80	90, 100	110, 120, 125	150	175, 200	
<b>CXS2M10</b>		55	30	40	50	60	70	80	—	72
<b>CXS2M16</b>		60	25	35	45	55	65	75	145	79

# CXS2-XB24

Dimensions:  $\varnothing 20$ ,  $\varnothing 25$ ,  $\varnothing 32$

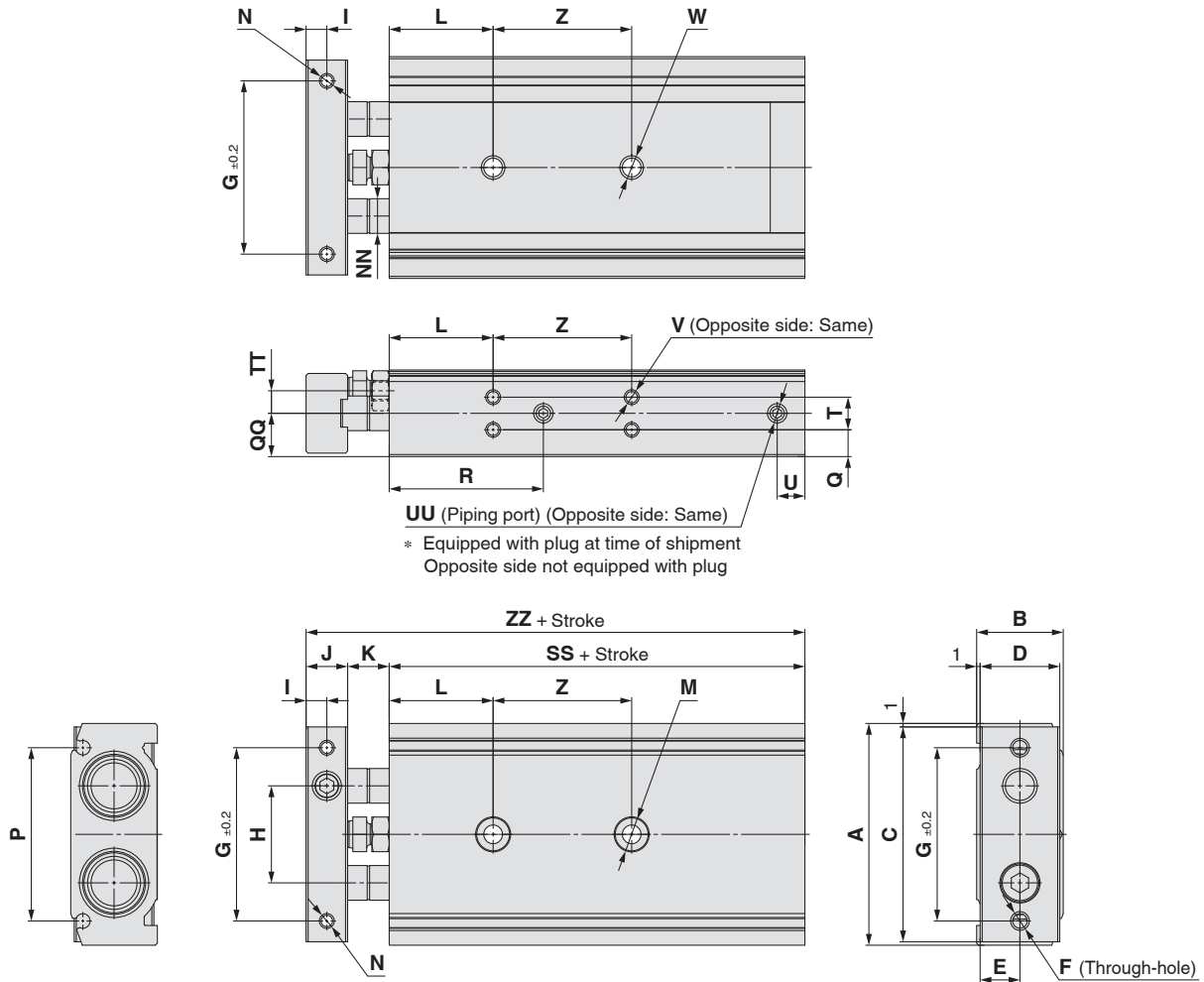

Model	A	B	C	D	E	F	G	H	I	J	K	L	M	N	NN	P
CXS2M20	64	25	62	23	11.5	2 x M5 x 0.8	50	28	6	12	12	30	2 x $\varnothing 5.5$ through 2 x $\varnothing 9.5$ counterbore depth 5.3	2 x M4 x 0.7 thread depth 6	$\varnothing 10$	50
CXS2M25	80	30	78	28	14	2 x M6 x 1.0	60	35	6	12	12	30	2 x $\varnothing 6.9$ through 2 x $\varnothing 11$ counterbore depth 6.3	2 x M5 x 0.8 thread depth 7.5	$\varnothing 12$	59.6
CXS2M32	98	38	96	36	18	2 x M6 x 1.0	75	44	8	16	14	30	2 x $\varnothing 6.9$ through 2 x $\varnothing 11$ counterbore depth 6.3	2 x M5 x 0.8 thread depth 8	$\varnothing 16$	75

Model	Q	QQ	R	T	TT	U	UU			V	W
							—	TN	TF		
CXS2M20	7.75	12.5	45	9.5	6.5	8	4 x M5 x 0.8	—	—	8 x M4 x 0.7 thread depth 5.5	2 x M6 x 1.0 thread depth 10
CXS2M25	8.5	15	46	13	9	9	4 x Rc1/8	4 x NPT1/8	4 x G1/8	8 x M5 x 0.8 thread depth 7.5	2 x M8 x 1.25 thread depth 12
CXS2M32	9	19	56	20	11.5	10				8 x M5 x 0.8 thread depth 7.5	2 x M8 x 1.25 thread depth 12

## Dimensions by Stroke

Model	SS	Z					ZZ
		10, 15, 20, 25	30, 35, 40, 45, 50	60, 70, 75, 80, 90, 100	110, 120, 125, 150	175, 200	
CXS2M20	70	30	40	60	80	100	94
CXS2M25	72	30	40	60	80	100	96
CXS2M32	82	40	50	70	90	110	112

## CXS2-XB24

## Specific Product Precautions



Be sure to read this before handling the products. Refer to the back cover for safety instructions. For actuator and auto switch precautions, refer to the “Handling Precautions for SMC Products” and the “Operation Manual” on the SMC website: <https://www.smc.eu>

## Mounting

## Caution

1. **Make sure that the surface on which the cylinder is to be mounted is flat (reference value for flatness: 0.05 or less).**

Dual rod cylinders can be mounted from 3 directions, however, make sure that the surface on which the cylinder is to be mounted is flat (reference value for flatness: 0.05 or less). Otherwise, the accuracy of the piston rod operation is not achieved, and malfunctioning can occur.

2. **Piston rod must be retracted when mounting the cylinder.**

Scratches or gouges in the piston rod may lead to damaged bearings and/or seals and cause a malfunction or air leakage.

## Piping

## Caution

1. **Plug the appropriate supply port (s) according to the operating conditions.**

Dual rod cylinders have 2 supply ports for each operating direction (3 supply ports for  $\varnothing 6$  only). Plug the appropriate supply port according to the operating conditions. Depending on the operating conditions, change the position of the plugs. When changing the port position, use the removed plug or a new plug.

If reusing the removed plug, apply sealant, etc., before reassembly.

If using a new M5 plug, apply a thin layer of grease all the way around the male thread before use. In addition, clear any foreign matter adhered to the port the plug was removed from before piping. After reassembly, be sure to check for air leakage before operating the product.

Plug part no.: ( $\varnothing 6$ ) CXS10-08-28747B  
 ( $\varnothing 10$  to  $\varnothing 20$ ) CXS20-08-28749A  
 ( $\varnothing 25$  to  $\varnothing 32$ ) CYP025-08B29449A (Rc1/8)  
 CXS25-08-A3025B (NPT1/8)  
 CXS25-08-A3911A (G1/8)

## Stroke Adjustment

## Caution

1. **After adjusting the stroke, make sure to tighten the hexagon nut to prevent it from loosening.**

Dual rod cylinders have a bolt to adjust 0 to  $-5$  mm strokes on the retracted end (IN).

Loosen the hexagon nut to adjust the stroke; however, make sure to tighten the hexagon nut after making an adjustment.

2. **Never operate a cylinder with its bumper bolt removed. Also, do not attempt to tighten the bumper bolt without using a nut.**

If the bumper bolt is removed, the piston hits housing end surface causing damage to the cylinder. Therefore, do not use a cylinder without a bumper bolt.

Furthermore, if the bumper bolt is tightened without a nut, the piston seal is caught in the levelled part, damaging the seal.

## Stroke Adjustment

## Caution

3. **The bumper located at the end of the bumper bolts**  
 If the bumper has permanently settled onto the product or if it is lost, an order can be placed by using the part numbers listed below.

Bore size [mm]	6, 10, 15	20, 25	32
Part no.	CXS10-34A 28747	CXS20-34A 28749	CXS32-34A 28751
Qty.	1		

## Disassembly and Maintenance

## Caution

1. **Never use a cylinder with its plate removed.**

When removing the hexagon socket head cap screw on the end plate, the piston rod must be secured to prevent from rotating. However, if the sliding parts of the piston rod are scratched and gouged, a malfunction may occur.

2. **When disassembling and reassembling the cylinder, please contact SMC or refer to the separate operation manual.**

## Warning

1. **Take precautions when your hands are near the plate and housing.**

Take sufficient care to avoid getting your hands or fingers caught when the cylinder is operated.

## Operating Environment

## Caution

1. **Do not operate the cylinder in a pressurised environment.**  
 The pressurised air may flow inside the cylinder due to its construction.
2. **Do not use as a stopper. This may cause a malfunction. When using as a stopper, select a stopper cylinder (RS series) or a compact guide cylinder (MGP series).**

## Speed Adjustment

## Caution

1. **A sudden extension may occur with CXS2□6.**  
 CXS2□6 has a low internal volume and sudden extension/erratic movement may occur particularly when it is used at low speed. This sudden extension can be mitigated by combining the use of meter-in and meter-out speed controllers.

## Durability of The Cylinder

The durability of a longer life cylinder has been evaluated by comparison with the existing cylinders under SMC's test conditions.



The durability of a cylinder depends on the customer's operating conditions and operating environment.

Therefore, durability of four times or longer will not be guaranteed under all conditions.



## Safety Instructions

These safety instructions are intended to prevent hazardous situations and/or equipment damage. These instructions indicate the level of potential hazard with the labels of “Caution,” “Warning” or “Danger.” They are all important notes for safety and must be followed in addition to International Standards (ISO/IEC)<sup>1)</sup>, and other safety regulations.

-  **Caution:** **Caution** indicates a hazard with a low level of risk which, if not avoided, could result in minor or moderate injury.
-  **Warning:** **Warning** indicates a hazard with a medium level of risk which, if not avoided, could result in death or serious injury.
-  **Danger:** **Danger** indicates a hazard with a high level of risk which, if not avoided, will result in death or serious injury.

- 1) ISO 4414: Pneumatic fluid power – General rules relating to systems.  
ISO 4413: Hydraulic fluid power – General rules relating to systems.  
IEC 60204-1: Safety of machinery – Electrical equipment of machines.  
(Part 1: General requirements)  
ISO 10218-1: Manipulating industrial robots - Safety.  
etc.

## Warning

### 1. The compatibility of the product is the responsibility of the person who designs the equipment or decides its specifications.

Since the product specified here is used under various operating conditions, its compatibility with specific equipment must be decided by the person who designs the equipment or decides its specifications based on necessary analysis and test results. The expected performance and safety assurance of the equipment will be the responsibility of the person who has determined its compatibility with the product. This person should also continuously review all specifications of the product referring to its latest catalogue information, with a view to giving due consideration to any possibility of equipment failure when configuring the equipment.

### 2. Only personnel with appropriate training should operate machinery and equipment.

The product specified here may become unsafe if handled incorrectly. The assembly, operation and maintenance of machines or equipment including our products must be performed by an operator who is appropriately trained and experienced.

### 3. Do not service or attempt to remove product and machinery/equipment until safety is confirmed.

1. The inspection and maintenance of machinery/equipment should only be performed after measures to prevent falling or runaway of the driven objects have been confirmed.
2. When the product is to be removed, confirm that the safety measures as mentioned above are implemented and the power from any appropriate source is cut, and read and understand the specific product precautions of all relevant products carefully.
3. Before machinery/equipment is restarted, take measures to prevent unexpected operation and malfunction.

### 4. Contact SMC beforehand and take special consideration of safety measures if the product is to be used in any of the following conditions.

1. Conditions and environments outside of the given specifications, or use outdoors or in a place exposed to direct sunlight.
2. Installation on equipment in conjunction with atomic energy, railways, air navigation, space, shipping, vehicles, military, medical treatment, combustion and recreation, or equipment in contact with food and beverages, emergency stop circuits, clutch and brake circuits in press applications, safety equipment or other applications unsuitable for the standard specifications described in the product catalogue.
3. An application which could have negative effects on people, property, or animals requiring special safety analysis.
4. Use in an interlock circuit, which requires the provision of double interlock for possible failure by using a mechanical protective function, and periodical checks to confirm proper operation.

## Caution

### 1. The product is provided for use in manufacturing industries.

The product herein described is basically provided for peaceful use in manufacturing industries.

If considering using the product in other industries, consult SMC beforehand and exchange specifications or a contract if necessary. If anything is unclear, contact your nearest sales branch.

## Limited warranty and Disclaimer/Compliance Requirements

The product used is subject to the following “Limited warranty and Disclaimer” and “Compliance Requirements”. Read and accept them before using the product.

### Limited warranty and Disclaimer

1. The warranty period of the product is 1 year in service or 1.5 years after the product is delivered, whichever is first.<sup>2)</sup> Also, the product may have specified durability, running distance or replacement parts. Please consult your nearest sales branch.
  2. For any failure or damage reported within the warranty period which is clearly our responsibility, a replacement product or necessary parts will be provided. This limited warranty applies only to our product independently, and not to any other damage incurred due to the failure of the product.
  3. Prior to using SMC products, please read and understand the warranty terms and disclaimers noted in the specified catalogue for the particular products.
- 2) Vacuum pads are excluded from this 1 year warranty.  
A vacuum pad is a consumable part, so it is warranted for a year after it is delivered. Also, even within the warranty period, the wear of a product due to the use of the vacuum pad or failure due to the deterioration of rubber material are not covered by the limited warranty.

### Compliance Requirements

1. The use of SMC products with production equipment for the manufacture of weapons of mass destruction (WMD) or any other weapon is strictly prohibited.
2. The exports of SMC products or technology from one country to another are governed by the relevant security laws and regulations of the countries involved in the transaction. Prior to the shipment of a SMC product to another country, assure that all local rules governing that export are known and followed.

## Caution

### SMC products are not intended for use as instruments for legal metrology.

Measurement instruments that SMC manufactures or sells have not been qualified by type approval tests relevant to the metrology (measurement) laws of each country. Therefore, SMC products cannot be used for business or certification ordained by the metrology (measurement) laws of each country.

## Safety Instructions

Be sure to read “Handling Precautions for SMC Products” (M-E03-3) before using.



## SMC Corporation (Europe)

<b>Austria</b>	+43 (0)2262622800	www.smc.at	office@smc.at
<b>Belgium</b>	+32 (0)33551464	www.smc.be	info@smc.be
<b>Bulgaria</b>	+359 (0)2807670	www.smc.bg	office@smc.bg
<b>Croatia</b>	+385 (0)13707288	www.smc.hr	office@smc.hr
<b>Czech Republic</b>	+420 541424611	www.smc.cz	office@smc.cz
<b>Denmark</b>	+45 70252900	www.smc.dk.com	smc@smcdk.com
<b>Estonia</b>	+372 651 0370	www.smcee.ee	info@smcee.ee
<b>Finland</b>	+358 207513513	www.smc.fi	smc.fi@smc.fi
<b>France</b>	+33 (0)164761000	www.smc-france.fr	supportclient@smc-france.fr
<b>Germany</b>	+49 (0)61034020	www.smc.de	info@smc.de
<b>Greece</b>	+30 210 2717265	www.smchellas.gr	sales@smchellas.gr
<b>Hungary</b>	+36 23513000	www.smc.hu	office@smc.hu
<b>Ireland</b>	+353 (0)14039000	www.smcautomation.ie	sales@smcautomation.ie
<b>Italy</b>	+39 03990691	www.smcitalia.it	mailbox@smcitalia.it
<b>Latvia</b>	+371 67817700	www.smc.lv	info@smc.lv

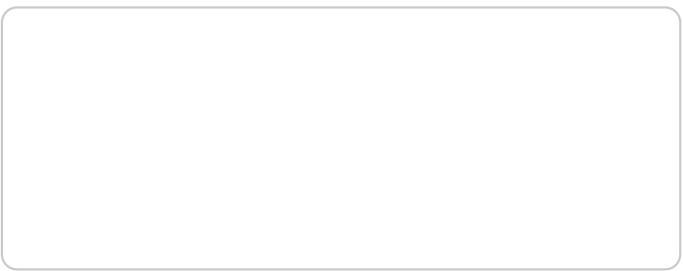

<b>Lithuania</b>	+370 5 2308118	www.smclt.lt	info@smclt.lt
<b>Netherlands</b>	+31 (0)205318888	www.smc.nl	info@smc.nl
<b>Norway</b>	+47 67129020	www.smc-norge.no	post@smc-norge.no
<b>Poland</b>	+48 222119600	www.smc.pl	office@smc.pl
<b>Portugal</b>	+351 214724500	www.smc.eu	apoioclientept@smc.smces.es
<b>Romania</b>	+40 213205111	www.smcromania.ro	smcromania@smcromania.ro
<b>Russia</b>	+7 (812)3036600	www.smc.eu	sales@smcru.com
<b>Slovakia</b>	+421 (0)413213212	www.smc.sk	office@smc.sk
<b>Slovenia</b>	+386 (0)73885412	www.smc.si	office@smc.si
<b>Spain</b>	+34 945184100	www.smc.eu	post@smc.smces.es
<b>Sweden</b>	+46 (0)86031240	www.smc.nu	smc@smc.nu
<b>Switzerland</b>	+41 (0)523963131	www.smc.ch	info@smc.ch
<b>Turkey</b>	+90 212 489 0 440	www.smcturkey.com.tr	info@smcturkey.com.tr
<b>UK</b>	+44 (0)845 121 5122	www.smc.uk	sales@smc.uk
<b>South Africa</b>	+27 10 900 1233	www.smcza.co.za	zasales@smcza.co.za