

High Durability Series

New

RoHS

# Longer Life Cylinder

## New technology offers at least **4 times better durability**

- The maintenance intervals will be extended

ISO Standards (21287)

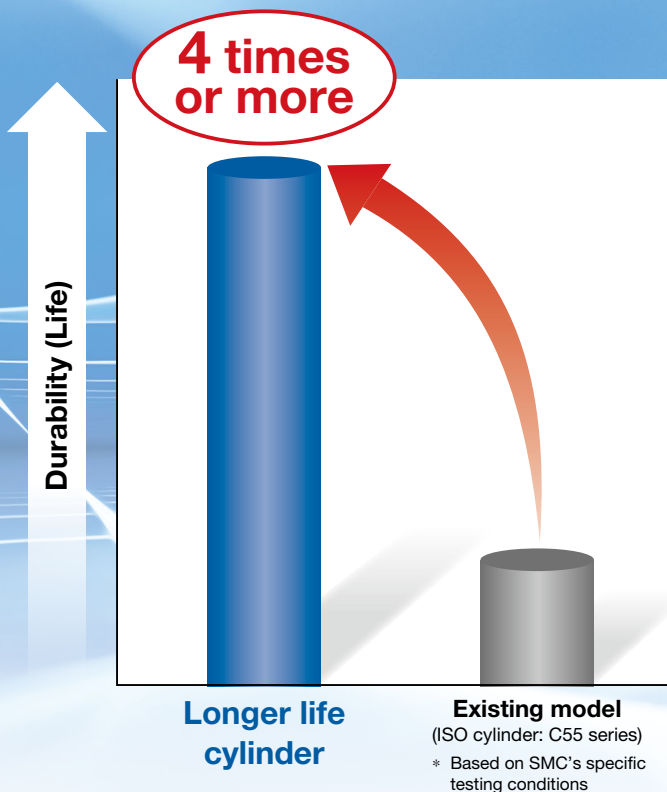

- Employs the same specifications and dimensions as the existing model, C55 ISO Cylinder series.

### High Durability Series

High Durability Series is the series name for the "special specification" that offers superior durability and environmental resistance compared to standard products.

### Series Variations

Series	Action	Model	Bore size [mm]				Stroke [mm]	Mounting bracket	Cushion
			20	25	32	40			
ISO cylinder C55 series 	Double acting, Single rod	<b>C55-XB24</b>	●	●	●	●	5 to 150	Through-hole/Both ends tapped common (Standard) Foot bracket Rod flange Head flange Single clevis	Rubber bumper on both ends

# C55-XB24



CAT.EUS20-312A-UK

Longer Life Cylinder  
Double Acting, Single Rod  
**C55-XB24**

∅ 20, ∅ 25, ∅ 32, ∅ 40



How to Order

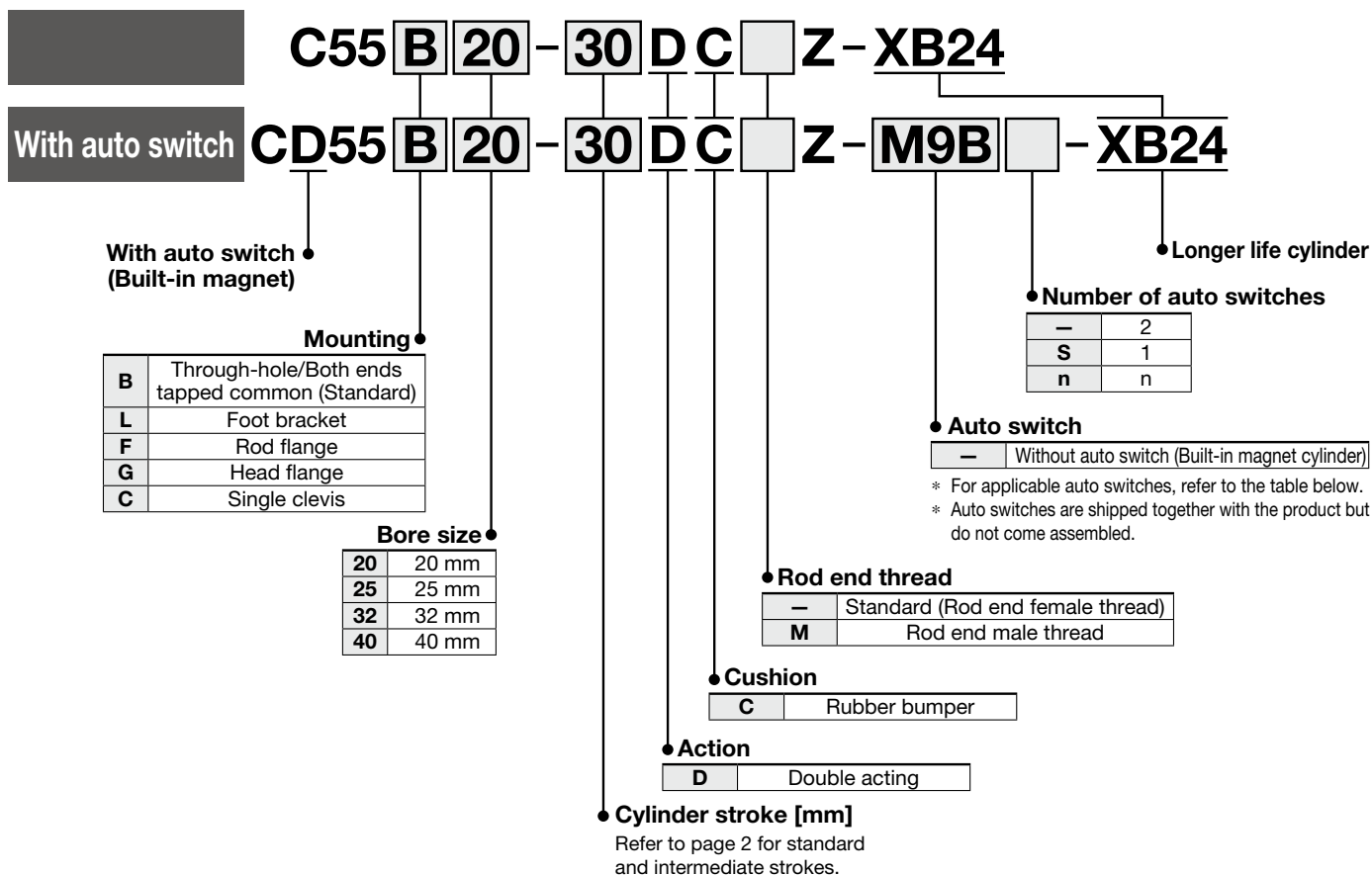

Applicable Auto Switches / Refer to the Web Catalogue for further information on auto switches.

Type	Special function	Electrical entry	Indicator light	Wiring (Output)	Load voltage		Auto switch model		Lead wire length [m]					Pre-wired connector	Applicable load					
					DC	AC	Perpendicular	In-line	0.5 (-)	1 (M)	3 (L)	5 (Z)	None (N)							
Solid state auto switch	—	Grommet	Yes	3-wire (NPN)	24 V	5 V, 12 V	—	M9NV	M9N	●	●	●	○	—	○	IC circuit	Relay, PLC			
				3-wire (PNP)				M9PV	M9P	●	●	●	○	—	○					
				2-wire				M9BV	M9B	●	●	●	○	—	○					
	Diagnostic indication (2-colour indicator)			3-wire (NPN)	24 V	5 V, 12 V	—	M9NV	M9N	●	●	●	○	—	○	IC circuit		Relay, PLC		
				3-wire (PNP)				M9PV	M9P	●	●	●	○	—	○					
				2-wire				M9BV	M9B	●	●	●	○	—	○					
	Water-resistant (2-colour indicator)			3-wire (NPN)	24 V	5 V, 12 V	—	M9NAV*1	M9NA*1	○	○	●	○	—	○	IC circuit			Relay, PLC	
				3-wire (PNP)				M9PAV*1	M9PA*1	○	○	●	○	—	○					
				2-wire				M9BAV*1	M9BA*1	○	○	●	○	—	○					
Reed auto switch	—	Grommet	Yes	3-wire (NPN equivalent)	24 V	5 V, 12 V	100 V or less	A96V	A96	●	—	●	—	—	—	IC circuit	—			
				2-wire				A93V*2	A93	●	●	●	●	—	—	—	—			Relay, PLC
				2-wire				A90V	A90	●	—	●	—	—	—	—	—			IC circuit

\*1 Water-resistant type auto switches can be mounted on the above models, but SMC cannot guarantee water resistance.

\*2 The 1 m lead wire is only applicable to the D-A93.

Lead wire length symbols: 0.5 m..... — (Example) M9NW  
 1 m..... M (Example) M9NWM  
 3 m..... L (Example) M9NWL  
 5 m..... Z (Example) M9NWZ

\* Solid state auto switches marked with a "○" are produced upon receipt of order.

\* Since there are other applicable auto switches than listed above, refer to the Web Catalogue for details.

\* Auto switches are shipped together with the product but do not come assembled.

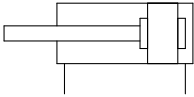

### Mounting Bracket Part Nos.

Bore size [mm]	Foot bracket	Flange	Single clevis
20	C55-L020	C55-F020	C55-C020
25	C55-L025	C55-F025	C55-C025
32	C55-L032	C55-F032	C55-C032
40	C55-L040	C55-F040	C55-C040

- \* Foot bracket part number contains two foot brackets.
- \* Mounting bolts are also included with bracket.

### Specifications

Bore size [mm]	20	25	32	40
Type	Pneumatic (Non-lube)			
Action	Double acting, Single rod			
Fluid	Air			
Proof pressure	1.5 MPa			
Maximum operating pressure	1.0 MPa			
Minimum operating pressure	0.05 MPa			
Ambient and fluid temperatures	Without auto switch: -10 to 70 °C (No freezing) With auto switch: -10 to 60 °C (No freezing)			
Cushion	Rubber bumper on both ends			
Stroke length tolerance*1	+1.0 0 mm			
Piston speed	50 to 500 mm/s			

\*1 Stroke length tolerance does not include the amount of bumper change.

### Standard Strokes

Bore size [mm]	Standard stroke [mm]
20 to 40	5, 10, 15, 20, 25, 30, 35, 40, 45, 50, 60, 80, 100, 125, 150

### Manufacturing of Intermediate Strokes

Description	Dealing with the stroke in 1 mm increments by using an exclusive body with the specified stroke
Part no.	Refer to "How to Order" for the standard model no. (page 1)
Stroke range	6 to 149 mm
Example	Part no.: C55B32-47DCZ-XB24 Makes 47 mm stroke tube

### ⚠ Precautions

Be sure to read this before handling the products. Refer to the back cover for safety instructions. For actuator and auto switch precautions, refer to the "Handling Precautions for SMC Products" and the "Operation Manual" on the SMC website: <https://www.smc.eu>

### ⚠ Caution

#### Durability of The Cylinder

The durability of a longer life cylinder has been evaluated by comparison with the existing cylinders under SMC's test conditions.

The durability of a cylinder depends on the customer's operating conditions and operating environment.

Therefore, durability of four times or longer will not be guaranteed under all conditions.

The allowable kinetic energy, allowable lateral loads at the rod end, theoretical output, weight, mounting bracket/parts numbers, and specifications with an auto switch, are equivalent to those of the ISO Cylinder C55 series. For details, refer to the Web Catalogue.

**Dimensions (With and without auto switch are the same size)**

Ø 20, Ø 25

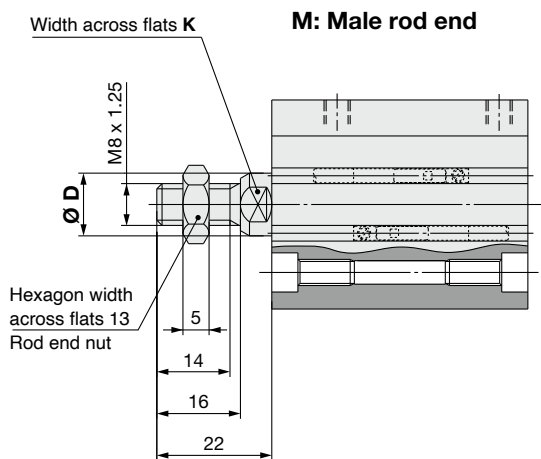
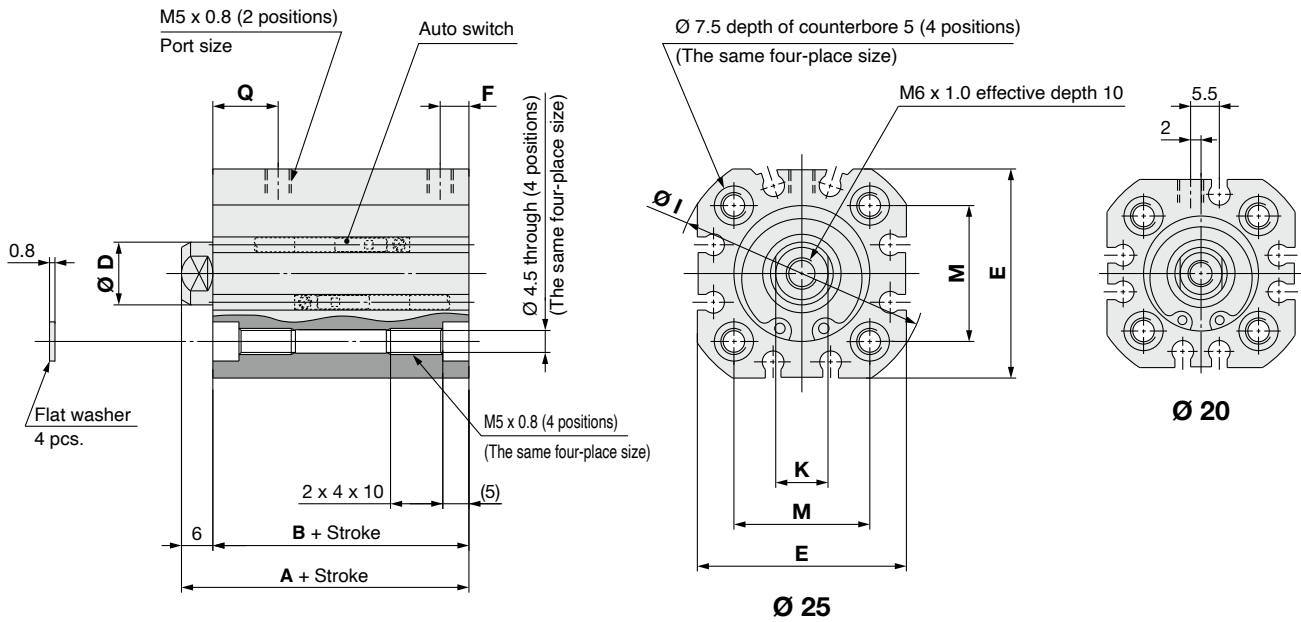

**Standard Type** [mm]

Bore size [mm]	A	B	D	E	I	K	M
20	43	37	10	36	43	8	22
25	45	39	12	40	48	10	26

**Male Rod End** [mm]

Bore size [mm]	D	K
20	10	8
25	12	10

\* Be sure to use the supplied flat washer when installing the cylinder with a through hole.

**Dimensions (With and without auto switch are the same size)**

Ø 32, Ø 40

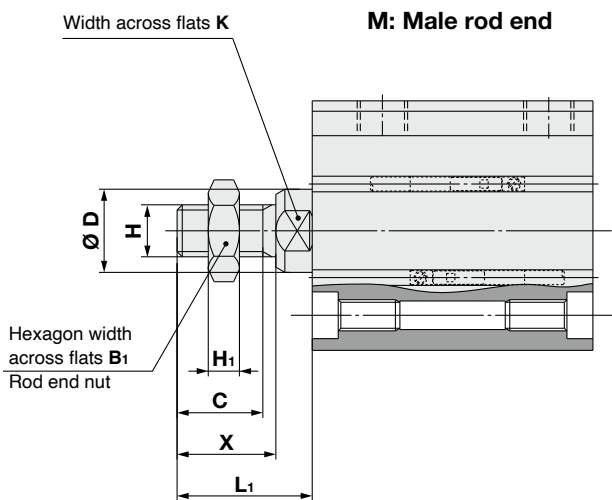
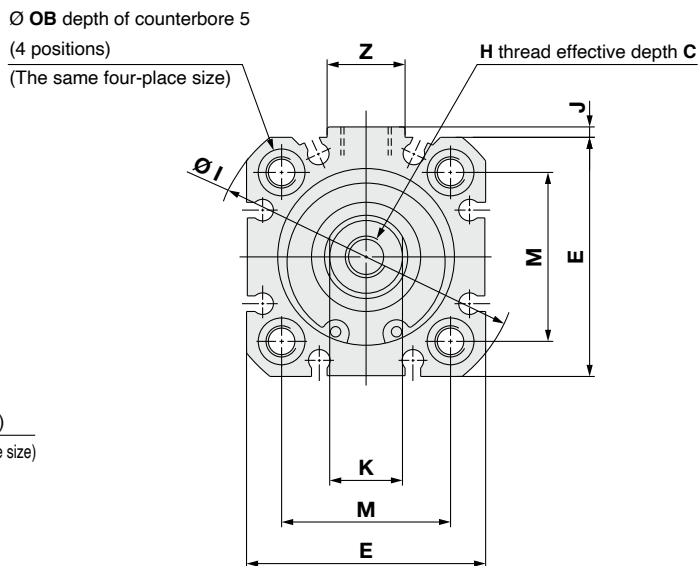
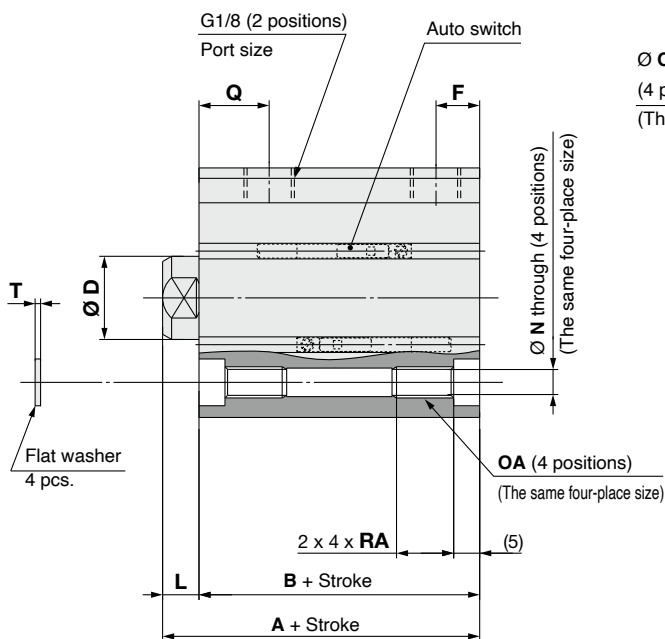

**Male Rod End**

Bore size [mm]	B <sub>1</sub>	C	D	H	H <sub>1</sub>	K	L <sub>1</sub>	X
32	17	16.5	16	M10 x 1.25	6	14	26	19
40	17	16.5	16	M10 x 1.25	6	14	26	19

**Standard Type**

Bore size [mm]	A	B	C	D	E	F	H	I	J	K	L	M	N	OA	OB	Q	RA	T	Z
32	51	44	12	16	46	8.5	M8 x 1.25	59	2	14	7	32.5	5.5	M6 x 1.0	9	11	11	1	15
40	52	45	12	16	52	9.5	M8 x 1.25	67	3	14	7	38	5.5	M6 x 1.0	9	14.5	11	1	17

\* Be sure to use the supplied flat washer when installing the cylinder with a through hole.

## Mounting Brackets

### Foot bracket

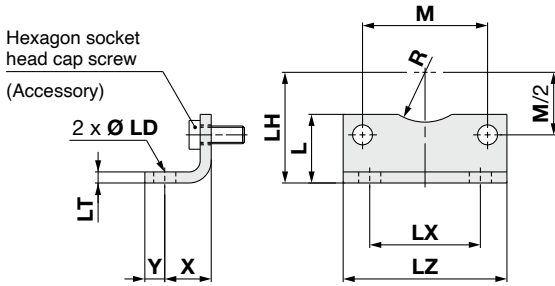

Material: Rolled steel  
Surface treatment: Nickel plating

Bore size [mm]	L	LD	LH	LT	LX	LZ	M	R	X	Y	Hexagon socket head cap screw	Weight [g]
20	22	7	27	4	22	36	22	8	16	7	M5	48
25	22	7	29	4	26	40	26	10	16	7	M5	52
32	24.5	7	33.5	4	32	46	32.5	15	16	7	M6	64
40	26	10	38	4	36	52	38	17.5	18	9	M6	78

\* The weight is the sum of the bracket and two hexagon socket head cap screws.

### Flange

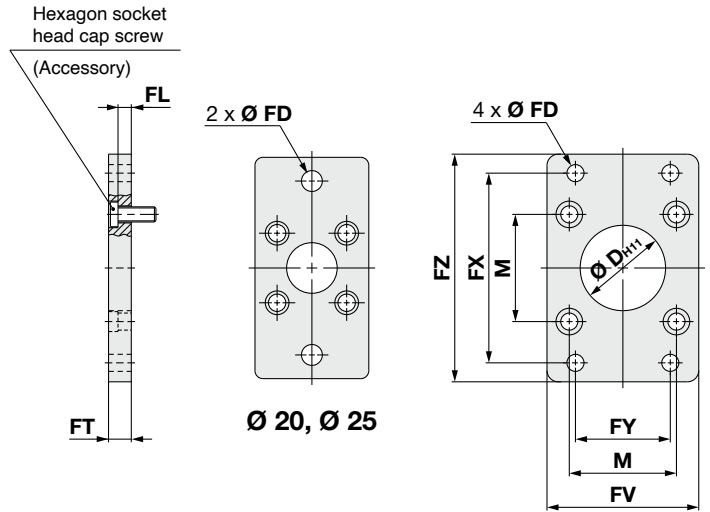

Material: Carbon steel  
Surface treatment: Nickel plating

Bore size [mm]	D	M	FD	FL	FT	FV	FX	FY	FZ	Hexagon socket head cap screw	Weight [g]
20	16	22	6.6	2.8	8	38	55	—	68	M5	151
25	16	26	6.6	2.8	8	38	60	—	73	M5	163
32	30	32.5	7	5	10	50	64	32	79	M6	202
40	35	38	9	5	10	55	72	36	90	M6	236

\* The weight is the sum of the bracket and four hexagon socket head cap screws.

### Single clevis

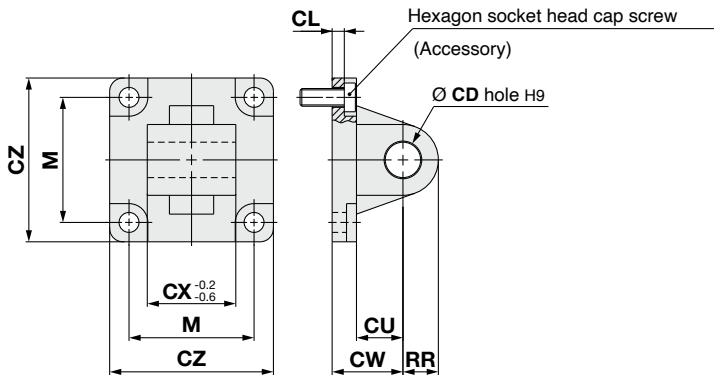

Material: Rolled steel  
Surface treatment: Nickel plating

Bore size [mm]	CD <sub>H9</sub>	CL	CU	CW	CX	CZ	M	RR	Hexagon socket head cap screw	Weight [g]
20	8	3	12	20	16	35	22	9	M5	114
25	8	3	12	20	16	40	26	9	M5	138
32	10	5.5	12	22	26	45	32.5	9.5	M6	145
40	12	5.5	15	25	28	51	38	12	M6	215

\* The weight is the sum of the bracket and four hexagon socket head cap screws.

### Rod End Nut

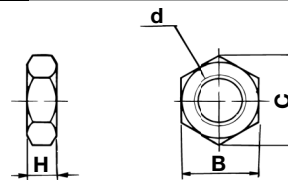

Material: Rolled steel  
Surface treatment: Zinc chromated

Bore size [mm]	Part no.	d	H	B	C	Weight [g]
20, 25	DA00040	M8 x 1.25	5	13	15.0	4
32, 40	DA00010	M10 x 1.25	6	17	19.6	8

## Safety Instructions

These safety instructions are intended to prevent hazardous situations and/or equipment damage. These instructions indicate the level of potential hazard with the labels of “Caution,” “Warning” or “Danger.” They are all important notes for safety and must be followed in addition to International Standards (ISO/IEC)<sup>1)</sup>, and other safety regulations.

### Danger:

**Danger** indicates a hazard with a high level of risk which, if not avoided, will result in death or serious injury.

### Warning:

**Warning** indicates a hazard with a medium level of risk which, if not avoided, could result in death or serious injury.

### Caution:

**Caution** indicates a hazard with a low level of risk which, if not avoided, could result in minor or moderate injury.

- 1) ISO 4414: Pneumatic fluid power – General rules and safety requirements for systems and their components.
- ISO 4413: Hydraulic fluid power – General rules and safety requirements for systems and their components.
- IEC 60204-1: Safety of machinery – Electrical equipment of machines. (Part 1: General requirements)
- ISO 10218-1: Robots and robotic devices - Safety requirements for industrial robots - Part 1: Robots.
- etc.

## Warning

### 1. The compatibility of the product is the responsibility of the person who designs the equipment or decides its specifications.

Since the product specified here is used under various operating conditions, its compatibility with specific equipment must be decided by the person who designs the equipment or decides its specifications based on necessary analysis and test results. The expected performance and safety assurance of the equipment will be the responsibility of the person who has determined its compatibility with the product. This person should also continuously review all specifications of the product referring to its latest catalogue information, with a view to giving due consideration to any possibility of equipment failure when configuring the equipment.

### 2. Only personnel with appropriate training should operate machinery and equipment.

The product specified here may become unsafe if handled incorrectly. The assembly, operation and maintenance of machines or equipment including our products must be performed by an operator who is appropriately trained and experienced.

### 3. Do not service or attempt to remove product and machinery/equipment until safety is confirmed.

1. The inspection and maintenance of machinery/equipment should only be performed after measures to prevent falling or runaway of the driven objects have been confirmed.
2. When the product is to be removed, confirm that the safety measures as mentioned above are implemented and the power from any appropriate source is cut, and read and understand the specific product precautions of all relevant products carefully.
3. Before machinery/equipment is restarted, take measures to prevent unexpected operation and malfunction.

### 4. Our products cannot be used beyond their specifications. Our products are not developed, designed, and manufactured to be used under the following conditions or environments. Use under such conditions or environments is not covered.

1. Conditions and environments outside of the given specifications, or use outdoors or in a place exposed to direct sunlight.
2. Use for nuclear power, railways, aviation, space equipment, ships, vehicles, military application, equipment affecting human life, body, and property, fuel equipment, entertainment equipment, emergency shut-off circuits, press clutches, brake circuits, safety equipment, etc., and use for applications that do not conform to standard specifications such as catalogues and operation manuals.
3. Use for interlock circuits, except for use with double interlock such as installing a mechanical protection function in case of failure. Please periodically inspect the product to confirm that the product is operating properly.

## Caution

**We develop, design, and manufacture our products to be used for automatic control equipment, and provide them for peaceful use in manufacturing industries.**

**Use in non-manufacturing industries is not covered.**

Products we manufacture and sell cannot be used for the purpose of transactions or certification specified in the Measurement Act.

The new Measurement Act prohibits use of any unit other than SI units in Japan.

## Limited warranty and Disclaimer/Compliance Requirements

The product used is subject to the following “Limited warranty and Disclaimer” and “Compliance Requirements”. Read and accept them before using the product.

### Limited warranty and Disclaimer

1. The warranty period of the product is 1 year in service or 1.5 years after the product is delivered, whichever is first.<sup>2)</sup> Also, the product may have specified durability, running distance or replacement parts. Please consult your nearest sales branch.
2. For any failure or damage reported within the warranty period which is clearly our responsibility, a replacement product or necessary parts will be provided. This limited warranty applies only to our product independently, and not to any other damage incurred due to the failure of the product.
3. Prior to using SMC products, please read and understand the warranty terms and disclaimers noted in the specified catalogue for the particular products.
- 2) Vacuum pads are excluded from this 1 year warranty.  
A vacuum pad is a consumable part, so it is warranted for a year after it is delivered. Also, even within the warranty period, the wear of a product due to the use of the vacuum pad or failure due to the deterioration of rubber material are not covered by the limited warranty.

### Compliance Requirements

1. The use of SMC products with production equipment for the manufacture of weapons of mass destruction (WMD) or any other weapon is strictly prohibited.
2. The exports of SMC products or technology from one country to another are governed by the relevant security laws and regulations of the countries involved in the transaction. Prior to the shipment of a SMC product to another country, assure that all local rules governing that export are known and followed.

## Safety Instructions

Be sure to read “Handling Precautions for SMC Products” (M-E03-3) before using.

## SMC Corporation (Europe)

<b>Austria</b>	+43 (0)2262622800	www.smc.at	office@smc.at
<b>Belgium</b>	+32 (0)33551464	www.smc.be	info@smc.be
<b>Bulgaria</b>	+359 (0)2807670	www.smc.bg	office@smc.bg
<b>Croatia</b>	+385 (0)13707288	www.smc.hr	office@smc.hr
<b>Czech Republic</b>	+420 541424611	www.smc.cz	office@smc.cz
<b>Denmark</b>	+45 70252900	www.smc.dk.com	smc@smcdk.com
<b>Estonia</b>	+372 651 0370	www.smcee.ee	info@smcee.ee
<b>Finland</b>	+358 207513513	www.smc.fi	smc.fi@smc.fi
<b>France</b>	+33 (0)164761000	www.smc-france.fr	supportclient@smc-france.fr
<b>Germany</b>	+49 (0)61034020	www.smc.de	info@smc.de
<b>Greece</b>	+30 210 2717265	www.smchellas.gr	sales@smchellas.gr
<b>Hungary</b>	+36 23513000	www.smc.hu	office@smc.hu
<b>Ireland</b>	+353 (0)14039000	www.smcautomation.ie	sales@smcautomation.ie
<b>Italy</b>	+39 03990691	www.smcitalia.it	mailbox@smcitalia.it
<b>Latvia</b>	+371 67817700	www.smc.lv	info@smc.lv

<b>Lithuania</b>	+370 5 2308118	www.smclt.lt	info@smclt.lt
<b>Netherlands</b>	+31 (0)205318888	www.smc.nl	info@smc.nl
<b>Norway</b>	+47 67129020	www.smc-norge.no	post@smc-norge.no
<b>Poland</b>	+48 222119600	www.smc.pl	sales@smc.pl
<b>Portugal</b>	+351 214724500	www.smc.eu	apoioclientept@smc.smces.es
<b>Romania</b>	+40 213205111	www.smcromania.ro	smcromania@smcromania.ro
<b>Russia</b>	+7 (812)3036600	www.smc.eu	sales@smcru.com
<b>Slovakia</b>	+421 (0)413213212	www.smc.sk	office@smc.sk
<b>Slovenia</b>	+386 (0)73885412	www.smc.si	office@smc.si
<b>Spain</b>	+34 945184100	www.smc.eu	post@smc.smces.es
<b>Sweden</b>	+46 (0)86031240	www.smc.nu	smc@smc.nu
<b>Switzerland</b>	+41 (0)523963131	www.smc.ch	info@smc.ch
<b>Turkey</b>	+90 212 489 0 440	www.smcturkey.com.tr	info@smcturkey.com.tr
<b>UK</b>	+44 (0)845 121 5122	www.smc.uk	sales@smc.uk

**South Africa** +27 10 900 1233    www.smcza.co.za    zasales@smcza.co.za