

Pulse Blow Valve

[Built-in Pilot Valve]

The peak pressure of repeatedly colliding air permits efficient blowing.

CO₂ emissions (Air consumption)

50 % reduction

* Depending on pulse conditions (ON/OFF time)

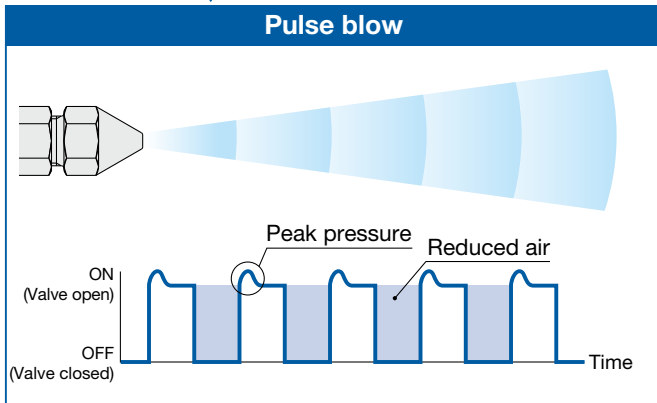

Control for pulse generation is not required.

Pulse blow can be used by simply supplying air.

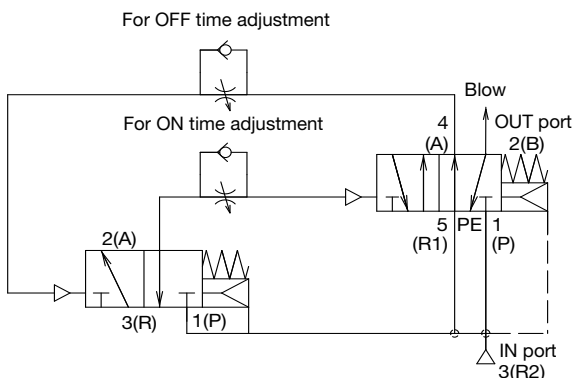
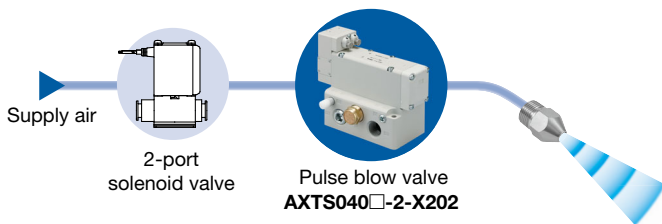

AXTS040-X202

Number of needle rotations: 0 to 8 rotations

New

RoHS

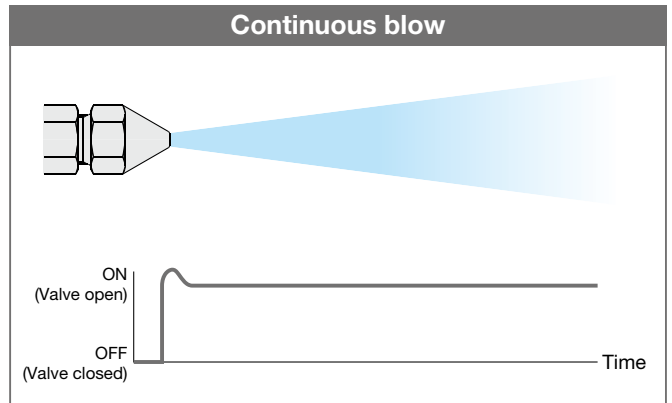
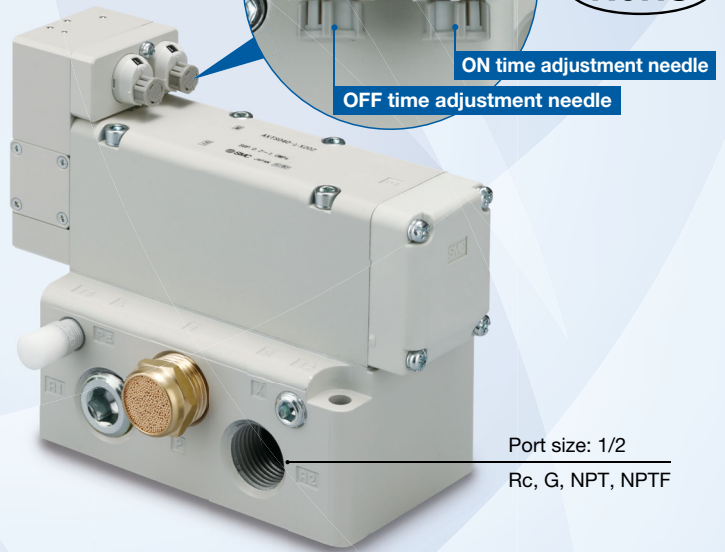

Built-in pilot valve construction allows for stable blowing.

* The construction, which is less susceptible to operating conditions such as piping diameter and length and nozzle type, allows for easy and stable pulse blow.

Application example

Blowing debris and coolant off the engine block

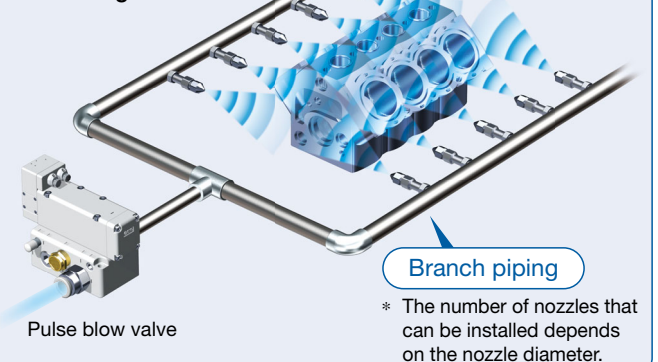

- Individually adjustable ON/OFF times
- Operating pressure range: 0.2 to 1.0 MPa
- Operating frequency (Frequency): 1 to 12 Hz



CAT.EUS11-122A-UK

Pulse Blow Valve

AXTS040- -2-X202

RoHS

How to Order

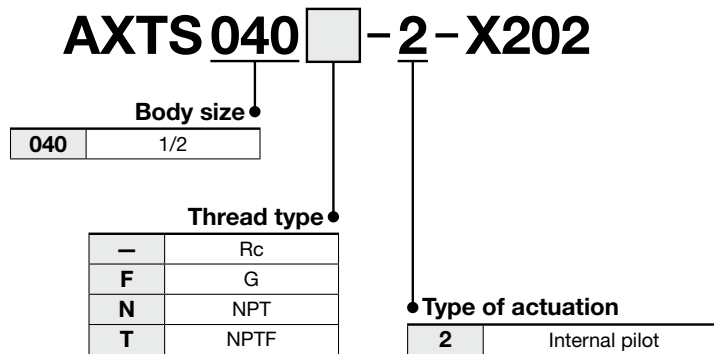

Specifications

Model		AXTS040 -2-X202
Type of actuation		Internal pilot
Valve construction		Metal seal
Fluid		Air
Operating pressure range		0.2 to 1.0 MPa
Frequency adjustment range		1 to 12 Hz
Proof pressure		1.5 MPa
Ambient and fluid temperatures		-5 to 50 °C (No freezing)
Lubrication		Not required
Weight		Approx. 1400 g
Flow rate characteristics (IN port → OUT port)	C[dm³/(s·bar)]	14
	b	0.18
	Cv	3.4
	Q[l/min (ANR)]*1	3316

*1 The AXTS series is air operated. Ensure that pressure in the inlet port (P1) does not drop below the valve's minimum operating pressure (0.2 MPa) during operation.

Silencers Part Numbers

Product part no.	Silencer part no.		Thread type
	Silencer A [For PE port]	Silencer B [For 1(P) port]	
AXTS040-2-X202	AN10-01	EBKX-L7007-120	Rc
AXTS040F-2-X202	AN10-01	EBKX-L7007F-120	G
AXTS040N-2-X202	AN10-N01	EBKX-L7007N-120	NPT
AXTS040T-2-X202	AN10-N01	EBKX-L7007N-120	NPTF

Dimensions

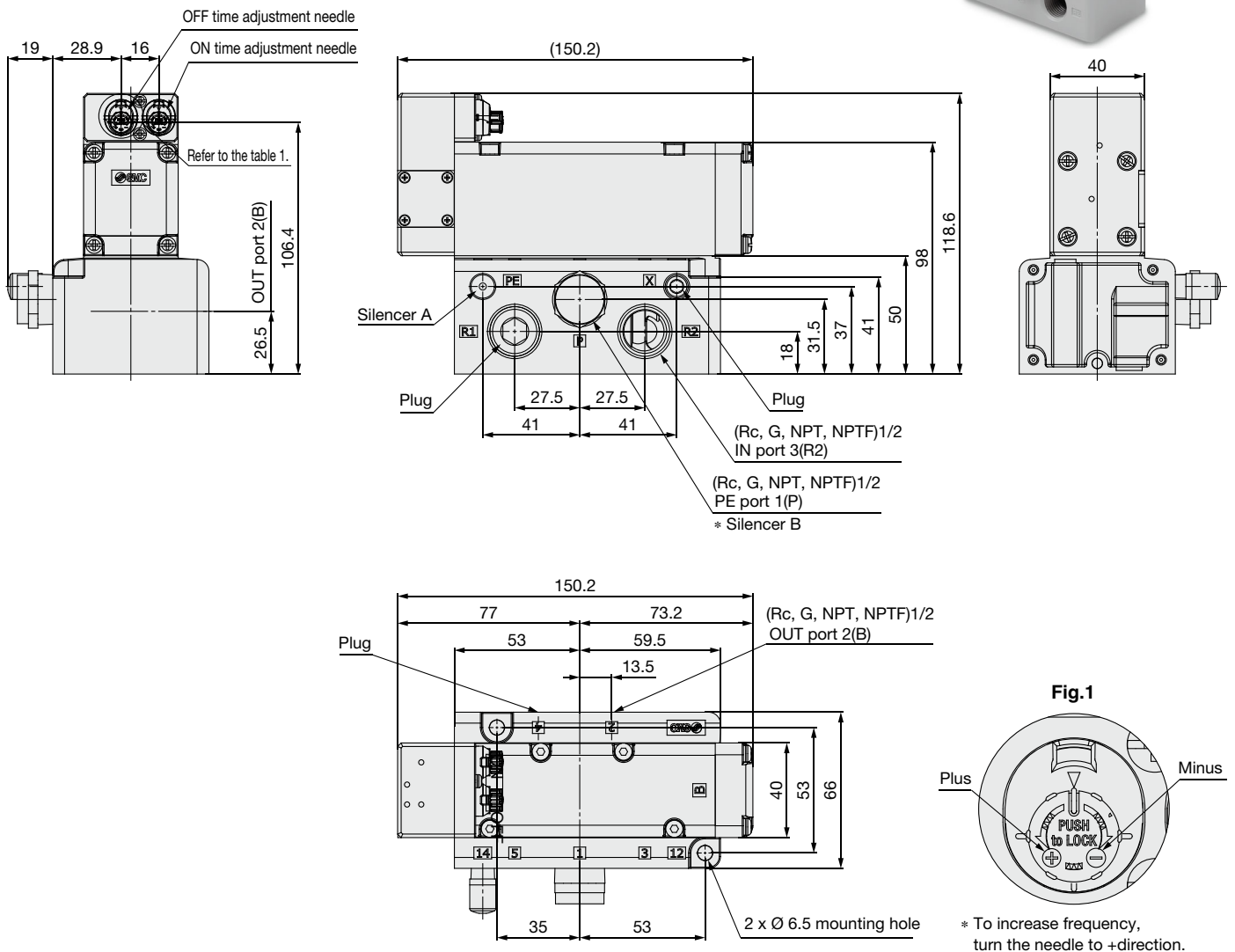

⚠ Specific Product Precautions

Be sure to read this before handling the products. For safety instructions and 2 -port solenoid valve for fluid control precautions, refer to the "Handling Precautions for SMC Products" and the "Operation Manual" on the SMC website: <https://www.smc.eu>

⚠ Caution

- This valve converts continuous air blowing into intermittent air blowing. No wiring required. AXTS040 valve can be installed between the existing blow valve and the nozzle.

The adjustment needles allows to adjust ON/OFF times (frequency) individually. For more information, please refer to the table below and the operation manual.

Adjustment needle	Decrease (-direction, clockwise)	↔	Increase (+direction, counterclockwise)
Frequency (Operating frequency)	Low	↔	High
ON time adjustment needle	ON time: Long	↔	ON time: Short
OFF time adjustment needle	OFF time: Long	↔	OFF time: Short

- This product has a large effective area and can provide a large flow rate. To effectively use the pulse blow valve, it is recommended that the nozzle used downstream the pulse valve is at least 4 mm orifice diameter. Otherwise, the recommendation is to use multiple nozzles with a total equivalent effective area equal or higher than a 4 mm orifice diameter nozzle.

To reduce air consumption, set the needle for the ON time to be short. (Set the OFF scale smaller and the ON scale larger.) For more information, refer to the operation manual.

⚠ Caution

- The breathing hole and pilot exhaust hole are located at the bottom of the pilot plate, so the bottom of the pilot plate should not be blocked.

For more information, refer to the operation manual.

- The sliding parts of this product are lubricated. Be aware that due to the construction, some lubricant may flow out to the outlet side with the blow air.



- This valve is internally air operated, and intermittent operation will start when air is supplied to the inlet port (P). Air will continue to be discharged from the exhaust port (PE port) as long as air is supplied to the inlet port (P) of the pulse valve, even if out port (A) is sealed with a plug or another valve is installed blocking the air consumption downstream the pulse valve.

Therefore, install a component upstream the pulse valve to shut off the air supply to the inlet port (P) of this product.

- If clogging in the nozzle or filter takes place in operation, air blow discharge pressure decreases, resulting in ineffective pulse blow. Perform periodic maintenance.

Safety Instructions

These safety instructions are intended to prevent hazardous situations and/or equipment damage. These instructions indicate the level of potential hazard with the labels of “Caution,” “Warning” or “Danger.” They are all important notes for safety and must be followed in addition to International Standards (ISO/IEC)¹⁾, and other safety regulations.

	Danger:	Danger indicates a hazard with a high level of risk which, if not avoided, will result in death or serious injury.
	Warning:	Warning indicates a hazard with a medium level of risk which, if not avoided, could result in death or serious injury.
	Caution:	Caution indicates a hazard with a low level of risk which, if not avoided, could result in minor or moderate injury.

- 1) ISO 4414: Pneumatic fluid power – General rules and safety requirements for systems and their components.
ISO 4413: Hydraulic fluid power – General rules and safety requirements for systems and their components.
IEC 60204-1: Safety of machinery – Electrical equipment of machines. (Part 1: General requirements)
ISO 10218-1: Robots and robotic devices - Safety requirements for industrial robots - Part 1: Robots.
etc.

Warning

1. The compatibility of the product is the responsibility of the person who designs the equipment or decides its specifications.

Since the product specified here is used under various operating conditions, its compatibility with specific equipment must be decided by the person who designs the equipment or decides its specifications based on necessary analysis and test results. The expected performance and safety assurance of the equipment will be the responsibility of the person who has determined its compatibility with the product. This person should also continuously review all specifications of the product referring to its latest catalogue information, with a view to giving due consideration to any possibility of equipment failure when configuring the equipment.

2. Only personnel with appropriate training should operate machinery and equipment.

The product specified here may become unsafe if handled incorrectly. The assembly, operation and maintenance of machines or equipment including our products must be performed by an operator who is appropriately trained and experienced.

3. Do not service or attempt to remove product and machinery/equipment until safety is confirmed.

1. The inspection and maintenance of machinery/equipment should only be performed after measures to prevent falling or runaway of the driven objects have been confirmed.
2. When the product is to be removed, confirm that the safety measures as mentioned above are implemented and the power from any appropriate source is cut, and read and understand the specific product precautions of all relevant products carefully.
3. Before machinery/equipment is restarted, take measures to prevent unexpected operation and malfunction.

4. Our products cannot be used beyond their specifications. Our products are not developed, designed, and manufactured to be used under the following conditions or environments.

Use under such conditions or environments is not covered.

1. Conditions and environments outside of the given specifications, or use outdoors or in a place exposed to direct sunlight.
2. Use for nuclear power, railways, aviation, space equipment, ships, vehicles, military application, equipment affecting human life, body, and property, fuel equipment, entertainment equipment, emergency shut-off circuits, press clutches, brake circuits, safety equipment, etc., and use for applications that do not conform to standard specifications such as catalogues and operation manuals.
3. Use for interlock circuits, except for use with double interlock such as installing a mechanical protection function in case of failure. Please periodically inspect the product to confirm that the product is operating properly.

Caution

We develop, design, and manufacture our products to be used for automatic control equipment, and provide them for peaceful use in manufacturing industries.

Use in non-manufacturing industries is not covered.

Products we manufacture and sell cannot be used for the purpose of transactions or certification specified in the Measurement Act.

The new Measurement Act prohibits use of any unit other than SI units in Japan.

Limited warranty and Disclaimer/Compliance Requirements

The product used is subject to the following “Limited warranty and Disclaimer” and “Compliance Requirements”. Read and accept them before using the product.

Limited warranty and Disclaimer

1. The warranty period of the product is 1 year in service or 1.5 years after the product is delivered, whichever is first.²⁾ Also, the product may have specified durability, running distance or replacement parts. Please consult your nearest sales branch.
2. For any failure or damage reported within the warranty period which is clearly our responsibility, a replacement product or necessary parts will be provided. This limited warranty applies only to our product independently, and not to any other damage incurred due to the failure of the product.
3. Prior to using SMC products, please read and understand the warranty terms and disclaimers noted in the specified catalogue for the particular products.
- 2) Vacuum pads are excluded from this 1 year warranty.
A vacuum pad is a consumable part, so it is warranted for a year after it is delivered. Also, even within the warranty period, the wear of a product due to the use of the vacuum pad or failure due to the deterioration of rubber material are not covered by the limited warranty.

Compliance Requirements

1. The use of SMC products with production equipment for the manufacture of weapons of mass destruction (WMD) or any other weapon is strictly prohibited.
2. The exports of SMC products or technology from one country to another are governed by the relevant security laws and regulations of the countries involved in the transaction. Prior to the shipment of a SMC product to another country, assure that all local rules governing that export are known and followed.

Safety Instructions

Be sure to read “Handling Precautions for SMC Products” (M-E03-3) before using.

SMC Corporation (Europe)

Austria	+43 (0)2262622800	www.smc.at	office@smc.at
Belgium	+32 (0)33551464	www.smc.be	info@smc.be
Bulgaria	+359 (0)2807670	www.smc.bg	office@smc.bg
Croatia	+385 (0)13707288	www.smc.hr	office@smc.hr
Czech Republic	+420 541424611	www.smc.cz	office@smc.cz
Denmark	+45 70252900	www.smc.dk.com	smc@smcdk.com
Estonia	+372 651 0370	www.smcee.ee	info@smcee.ee
Finland	+358 207513513	www.smc.fi	smc.fi@smc.fi
France	+33 (0)164761000	www.smc-france.fr	supportclient@smc-france.fr
Germany	+49 (0)61034020	www.smc.de	info@smc.de
Greece	+30 210 2717265	www.smchellas.gr	sales@smchellas.gr
Hungary	+36 23513000	www.smc.hu	office@smc.hu
Ireland	+353 (0)14039000	www.smcautomation.ie	sales@smcautomation.ie
Italy	+39 03990691	www.smcitalia.it	mailbox@smcitalia.it
Latvia	+371 67817700	www.smc.lv	info@smc.lv

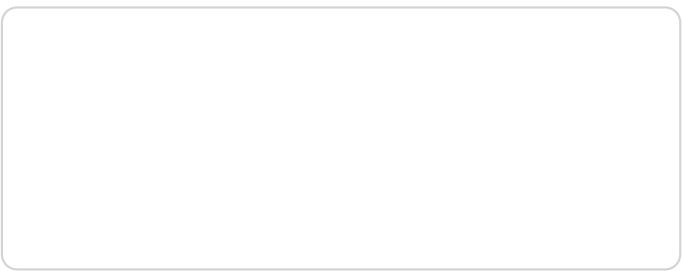

Lithuania	+370 5 2308118	www.smclt.lt	info@smclt.lt
Netherlands	+31 (0)205318888	www.smc.nl	info@smc.nl
Norway	+47 67129020	www.smc-norge.no	post@smc-norge.no
Poland	+48 222119600	www.smc.pl	sales@smc.pl
Portugal	+351 214724500	www.smc.eu	apoioclientept@smc.smces.es
Romania	+40 213205111	www.smcromania.ro	smcromania@smcromania.ro
Russia	+7 (812)3036600	www.smc.eu	sales@smcru.com
Slovakia	+421 (0)413213212	www.smc.sk	office@smc.sk
Slovenia	+386 (0)73885412	www.smc.si	office@smc.si
Spain	+34 945184100	www.smc.eu	post@smc.smces.es
Sweden	+46 (0)86031240	www.smc.nu	smc@smc.nu
Switzerland	+41 (0)523963131	www.smc.ch	info@smc.ch
Turkey	+90 212 489 0 440	www.smcturkey.com.tr	info@smcturkey.com.tr
UK	+44 (0)845 121 5122	www.smc.uk	sales@smc.uk
South Africa	+27 10 900 1233	www.smcza.co.za	zasales@smcza.co.za