

# Speed Controller with Pilot Check Valve

# Series ASP

RoHS

360° freedom for tube  
mounting direction  
Standard electroless nickel  
plating specification



## Model

Part No.	Port size	Pilot port	Applicable tube outside diameter										
			Millimeter size				Inch size						
			ø6	ø8	ø10	ø12	ø1/4"	ø5/16"	ø3/8"	ø1/2"			
ASP330F-01	R(PT)1/8	M5	•	•									
ASP430F-02	R(PT)1/4	Rc(PT)1/8	•	•									
ASP530F-03	R(PT)3/8	Rc(PT)1/8		•	•								
ASP630F-04	R(PT)1/2	Rc(PT)1/4			•	•							
ASP430F-F02	R(PT)1/4	G(PF)1/8	•	•									
ASP530F-F03	R(PT)3/8	G(PF)1/8		•	•								
ASP630F-F04	R(PT)1/2	G(PF)1/4			•	•							
ASP330F-N01	NPT1/8	10-32UNF						•	•				
ASP430F-N02	NPT1/4	NPT1/8						•	•				
ASP530F-N03	NPT3/8	NPT1/8							•	•			
ASP630F-N04	NPT1/2	NPT1/4								•	•		

Note) All brass parts are electroless nickel plated.

## Specifications

Proof pressure	1.5MPa{15.3kgf/cm <sup>2</sup> }
Maximum operating pressure	1MPa{10.2kgf/cm <sup>2</sup> }
Minimum operating pressure	0.1MPa{1kgf/cm <sup>2</sup> }
Pilot check valve actuation pressure	50% or more of operating pressure
Ambient & fluid temperature	-5 to 60°C (Without freezing)
Number of needle revolutions	10 revolutions
Applicable tube material	Nylon, Soft nylon, Polyurethane

Note) Use caution with soft nylon or polyurethane at maximum operating pressures.

## JIS Symbol

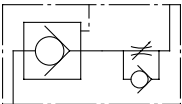

## Flow Rate and Effective Sectional Area

Model		ASP330F	ASP430F		ASP530F		ASP630F	
Tube outside diameter	Millimeter size	ø6, ø8	ø6	ø8	ø8	ø10	ø10	ø12
	Inch size	ø1/4" ø5/16"	—	ø1/4" ø5/16"	ø5/16"	ø3/8"	—	ø3/8" ø1/2"
Controlled flow (Free flow)	Flow rate ℓ/min (ANR){N ℓ/min}	180	330	350	600	750	1100	1190
	Effective sectional area mm <sup>2</sup>	2.9	5.2	5.4	9.3	11.6	17	18.4

Note) The indicated flow rate values are at a pressure of 0.5MPa and a temperature of 20°C.

# Series ASP

  
EMC-ASP-001A-UK

## How to Order

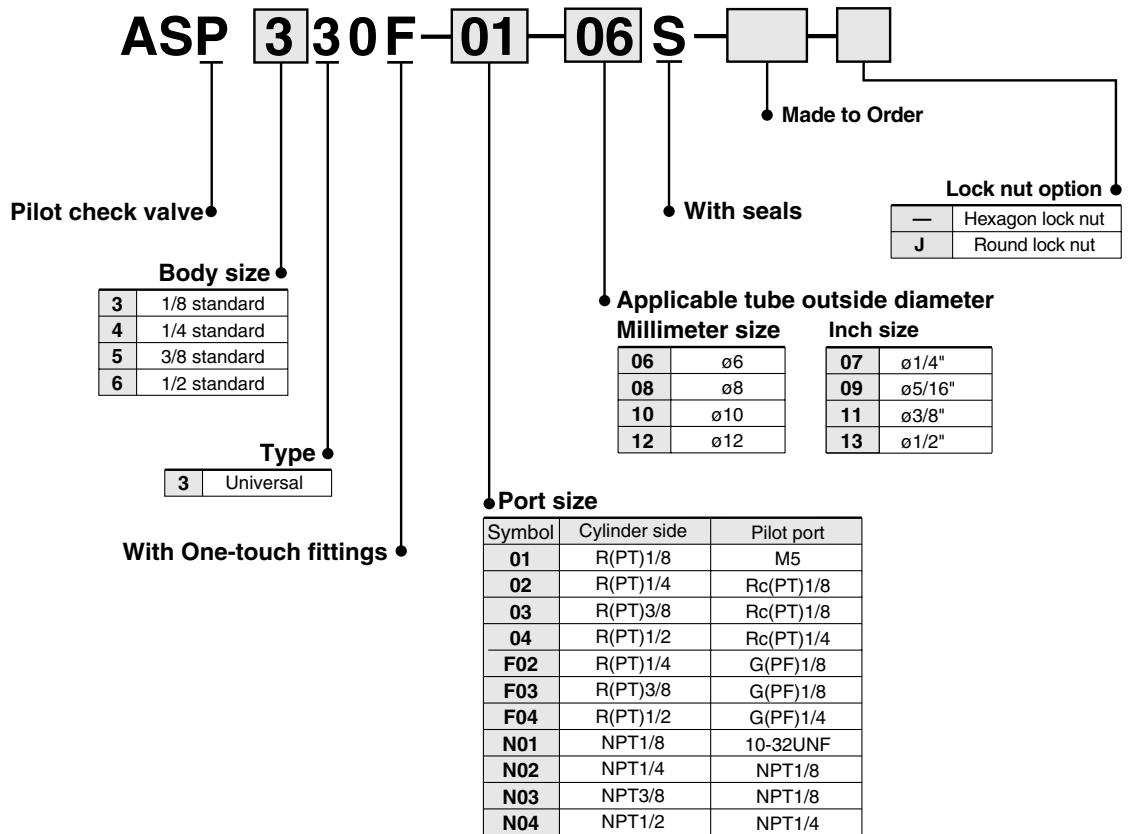

## Made to Order

**1** Lubricant: Vaseline

**X12**

## Needle Valve/Flow Rate Characteristics

**ASP330F**

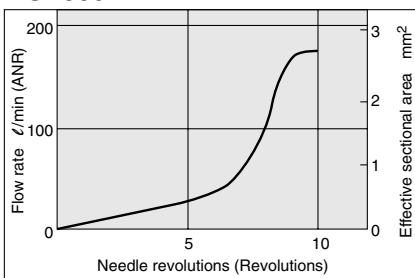

**ASP430F**

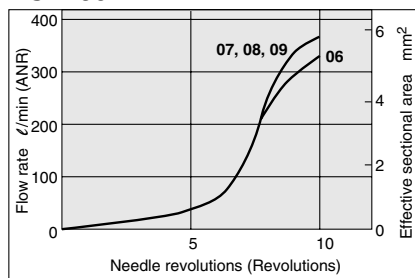

**ASP530F**

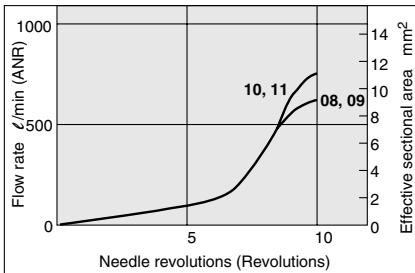

**ASP630F**

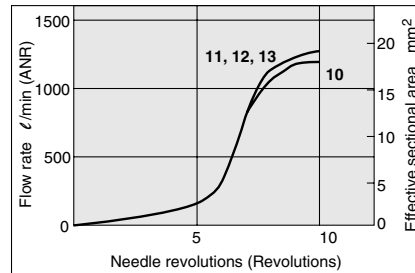

## Dimensions

### Millimeter size

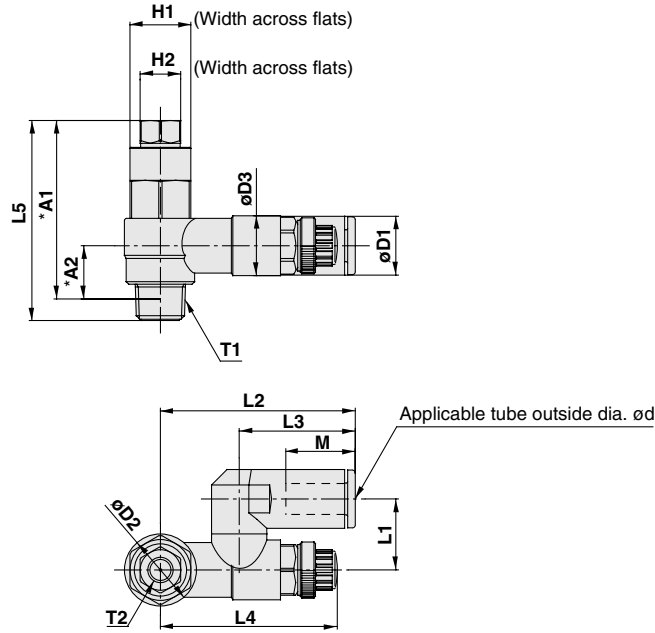

Model	d	T1	T2	H1	H2	D1	D2	D3	L1	L2	L3	L4		L5	*A1	*A2	M	Weight g
												MAX.	MIN.					
ASP330F-01-06S	6	1/8	M5	12	8	11.6	14.2	11.8	14	38.4	22.9	39.6	34.6	39.5	35.2	10.5	13.7	32
ASP330F-01-08S	8					15.2						38.9	33.9				18.7	35
ASP430F-02-06S	6	1/4	Rc(PT)1/8	17	12	12.8	18.5	15	18	43.4	25.2	41.7	36.7	48.7	42.4	10.9	16.8	65
ASP430F-02-08S	8					15.2											19.7	46.4
ASP530F-03-08S	8	3/8	Rc(PT)1/8	19	12	15.2	23	19.8	20.3	51.3	28.2	46.9	41.9	56.2	50	14.4	18.7	107
ASP530F-03-10S	10					18.5											23.1	54.1
ASP630F-04-10S	10	1/2	Rc(PT)1/4	24	17	18.5	28.6	26.5	25.9	64.2	32.6	64.8	57.3	70.3	61.8	18.3	20.8	212
ASP630F-04-12S	12					20.9											66	34.4

\* Reference dimensions for R(PT) threads after installation.

### Inch size

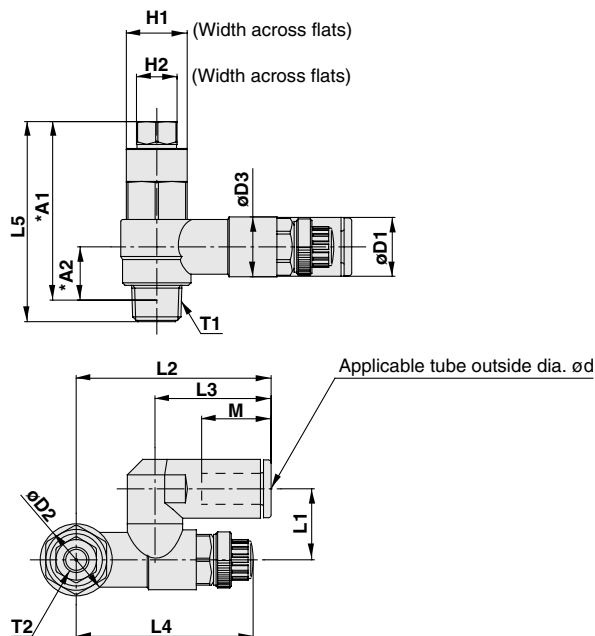

Model	d	T1	T2	H1	H2	D1	D2	D3	L1	L2	L3	L4		L5	*A1	*A2	M	Weight g
												MAX.	MIN.					
ASP330F-N01-07S	1/4"	NPT1/8	10-32UNF	1/2"	8	13.2	14.2	11.8	15.8	42.2	25.6	38.9	33.9	39.5	35.1	10.5	17	35
ASP330F-N01-09S	5/16"					15.2											44.7	
ASP430F-N02-07S	1/4"	NPT1/4	NPT1/8	11/16"	1/2"	13.2	18.5	15	18	43.9	25.6	41.7	36.7	48.7	42.6	10.9	17	68
ASP430F-N02-09S	5/16"					15.2											46.4	
ASP530F-N03-09S	5/16"	NPT3/8	NPT1/8	19	1/2"	15.2	23	19.8	20.3	51.3	28.2	46.9	41.9	56.2	50.3	14.4	18.7	107
ASP530F-N03-11S	3/8"					18.5											23.1	54.1
ASP630F-N04-11S	3/8"	NPT1/2	NPT1/4	15/16"	11/16"	18.5	28.6	26.5	25.9	64.2	32.6	64.8	57.3	70.3	61.8	18.3	20.8	220
ASP630F-N04-13S	1/2"					21.7											26.5	66.3

\* Reference dimensions for NPT threads after installation.

# Series ASP

## Construction

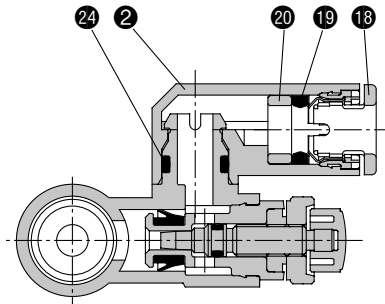
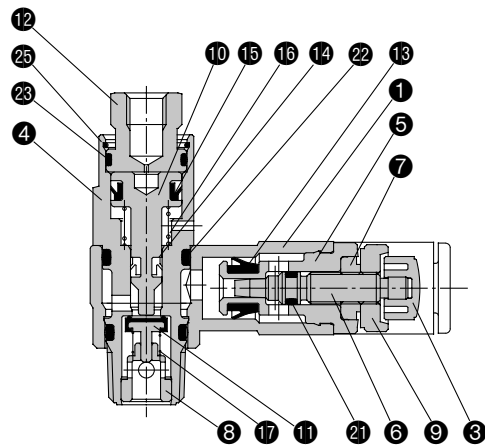

### Parts list



No.	Description	Material	Note
①	Body A	PBT	
②	Elbow body	PBT	
③	Knob	PBT	
④	Pilot body	Brass	Electroless nickel plated
⑤	Body B	Brass	Electroless nickel plated
⑥	Needle	Brass	Electroless nickel plated
⑦	Needle guide	Brass	Electroless nickel plated
⑧	Guide	Brass	Electroless nickel plated
⑨	Lock nut	Steel	Zinc chromated
⑩	Piston	Brass	Electroless nickel plated
⑪	Valve	Stainless steel, NBR	
⑫	Cover	Brass	Electroless nickel plated
⑬	U seal	HNBR	

### Parts list

No.	Description	Material	Note
⑭	DY seal	NBR	
⑮	DY seal	NBR	
⑯	Spring	Stainless steel	
⑰	Spring	Stainless steel	
⑱	Cassette	—	
⑲	Seal	NBR	
⑳	Spacer	—	
㉑	O-ring	NBR	
㉒	O-ring	NBR	
㉓	O-ring	NBR	
㉔	O-ring	NBR	
㉕	Ring	Stainless steel	

## Safety Instructions

These safety instructions are intended to prevent hazardous situations and/or equipment damage. These instructions indicate the level of potential hazard with the labels of “Caution,” “Warning” or “Danger.” They are all important notes for safety and must be followed in addition to International Standards (ISO/IEC) <sup>1)</sup>, and other safety regulations.

 <b>Caution:</b>	<b>Caution</b> indicates a hazard with a low level of risk which, if not avoided, could result in minor or moderate injury.
 <b>Warning:</b>	<b>Warning</b> indicates a hazard with a medium level of risk which, if not avoided, could result in death or serious injury.
 <b>Danger:</b>	<b>Danger</b> indicates a hazard with a high level of risk which, if not avoided, will result in death or serious injury.

- 1) ISO 4414: Pneumatic fluid power – General rules relating to systems.  
ISO 4413: Hydraulic fluid power – General rules relating to systems.  
IEC 60204-1: Safety of machinery – Electrical equipment of machines.  
(Part 1: General requirements)  
ISO 10218-1: Manipulating industrial robots - Safety.  
etc.

## Warning

### 1. The compatibility of the product is the responsibility of the person who designs the equipment or decides its specifications.

Since the product specified here is used under various operating conditions, its compatibility with specific equipment must be decided by the person who designs the equipment or decides its specifications based on necessary analysis and test results. The expected performance and safety assurance of the equipment will be the responsibility of the person who has determined its compatibility with the product. This person should also continuously review all specifications of the product referring to its latest catalogue information, with a view to giving due consideration to any possibility of equipment failure when configuring the equipment.

### 2. Only personnel with appropriate training should operate machinery and equipment.

The product specified here may become unsafe if handled incorrectly. The assembly, operation and maintenance of machines or equipment including our products must be performed by an operator who is appropriately trained and experienced.

### 3. Do not service or attempt to remove product and machinery/equipment until safety is confirmed.

1. The inspection and maintenance of machinery/equipment should only be performed after measures to prevent falling or runaway of the driven objects have been confirmed.
2. When the product is to be removed, confirm that the safety measures as mentioned above are implemented and the power from any appropriate source is cut, and read and understand the specific product precautions of all relevant products carefully.
3. Before machinery/equipment is restarted, take measures to prevent unexpected operation and malfunction.

### 4. Contact SMC beforehand and take special consideration of safety measures if the product is to be used in any of the following conditions.

1. Conditions and environments outside of the given specifications, or use outdoors or in a place exposed to direct sunlight.
2. Installation on equipment in conjunction with atomic energy, railways, air navigation, space, shipping, vehicles, military, medical treatment, combustion and recreation, or equipment in contact with food and beverages, emergency stop circuits, clutch and brake circuits in press applications, safety equipment or other applications unsuitable for the standard specifications described in the product catalogue.
3. An application which could have negative effects on people, property, or animals requiring special safety analysis.
4. Use in an interlock circuit, which requires the provision of double interlock for possible failure by using a mechanical protective function, and periodical checks to confirm proper operation.

## Caution

### 1. The product is provided for use in manufacturing industries.

The product herein described is basically provided for peaceful use in manufacturing industries. If considering using the product in other industries, consult SMC beforehand and exchange specifications or a contract if necessary. If anything is unclear, contact your nearest sales branch.

## Limited warranty and Disclaimer/Compliance Requirements

The product used is subject to the following “Limited warranty and Disclaimer” and “Compliance Requirements”. Read and accept them before using the product.

### Limited warranty and Disclaimer

1. The warranty period of the product is 1 year in service or 1.5 years after the product is delivered, whichever is first. <sup>2)</sup> Also, the product may have specified durability, running distance or replacement parts. Please consult your nearest sales branch.
2. For any failure or damage reported within the warranty period which is clearly our responsibility, a replacement product or necessary parts will be provided. This limited warranty applies only to our product independently, and not to any other damage incurred due to the failure of the product.
3. Prior to using SMC products, please read and understand the warranty terms and disclaimers noted in the specified catalogue for the particular products.
- 2) Vacuum pads are excluded from this 1 year warranty. A vacuum pad is a consumable part, so it is warranted for a year after it is delivered. Also, even within the warranty period, the wear of a product due to the use of the vacuum pad or failure due to the deterioration of rubber material are not covered by the limited warranty.

### Compliance Requirements

1. The use of SMC products with production equipment for the manufacture of weapons of mass destruction (WMD) or any other weapon is strictly prohibited.
2. The exports of SMC products or technology from one country to another are governed by the relevant security laws and regulations of the countries involved in the transaction. Prior to the shipment of a SMC product to another country, assure that all local rules governing that export are known and followed.

## Caution

### SMC products are not intended for use as instruments for legal metrology.

Measurement instruments that SMC manufactures or sells have not been qualified by type approval tests relevant to the metrology (measurement) laws of each country. Therefore, SMC products cannot be used for business or certification ordained by the metrology (measurement) laws of each country.

## Safety Instructions

Be sure to read “Handling Precautions for SMC Products” (M-E03-3) before using.

## SMC Corporation (Europe)

<b>Austria</b>	+43 (0)2262622800	www.smc.at	office@smc.at
<b>Belgium</b>	+32 (0)33551464	www.smc.be	info@smc.be
<b>Bulgaria</b>	+359 (0)2807670	www.smc.bg	office@smc.bg
<b>Croatia</b>	+385 (0)13707288	www.smc.hr	office@smc.hr
<b>Czech Republic</b>	+420 541424611	www.smc.cz	office@smc.cz
<b>Denmark</b>	+45 70252900	www.smc.dk.com	smc@smcdk.com
<b>Estonia</b>	+372 651 0370	www.smcee.ee	info@smcee.ee
<b>Finland</b>	+358 207513513	www.smc.fi	smcfl@smc.fi
<b>France</b>	+33 (0)164761000	www.smc-france.fr	supportclient@smc-france.fr
<b>Germany</b>	+49 (0)61034020	www.smc.de	info@smc.de
<b>Greece</b>	+30 210 2717265	www.smchellas.gr	sales@smchellas.gr
<b>Hungary</b>	+36 23513000	www.smc.hu	office@smc.hu
<b>Ireland</b>	+353 (0)14039000	www.smcautomation.ie	sales@smcautomation.ie
<b>Italy</b>	+39 03990691	www.smcitalia.it	mailbox@smcitalia.it
<b>Latvia</b>	+371 67817700	www.smc.lv	info@smc.lv

<b>Lithuania</b>	+370 5 2308118	www.smclt.lt	info@smclt.lt
<b>Netherlands</b>	+31 (0)205318888	www.smc.nl	info@smc.nl
<b>Norway</b>	+47 67129020	www.smc-norge.no	post@smc-norge.no
<b>Poland</b>	+48 222119600	www.smc.pl	office@smc.pl
<b>Portugal</b>	+351 214724500	www.smc.eu	apoioclientept@smc.smces.es
<b>Romania</b>	+40 213205111	www.smcromania.ro	smcromania@smcromania.ro
<b>Russia</b>	+7 (812)3036600	www.smc.eu	sales@smcru.com
<b>Slovakia</b>	+421 (0)413213212	www.smc.sk	office@smc.sk
<b>Slovenia</b>	+386 (0)73885412	www.smc.si	office@smc.si
<b>Spain</b>	+34 945184100	www.smc.eu	post@smc.smces.es
<b>Sweden</b>	+46 (0)86031240	www.smc.nu	smc@smc.nu
<b>Switzerland</b>	+41 (0)523963131	www.smc.ch	info@smc.ch
<b>Turkey</b>	+90 212 489 0 440	www.smcturkey.com.tr	satis@smcturkey.com.tr
<b>UK</b>	+44 (0)845 121 5122	www.smc.uk	sales@smc.uk

**South Africa** +27 10 900 1233    www.smcza.co.za    zasales@smcza.co.za