

Metal Speed Controller / Low Profile Type

New

RoHS

Improved environmental resistance with the all metal exterior

For use in environments with

Welding spatter

Dust

Ultraviolet

Improved installability using
a hexagon wrench

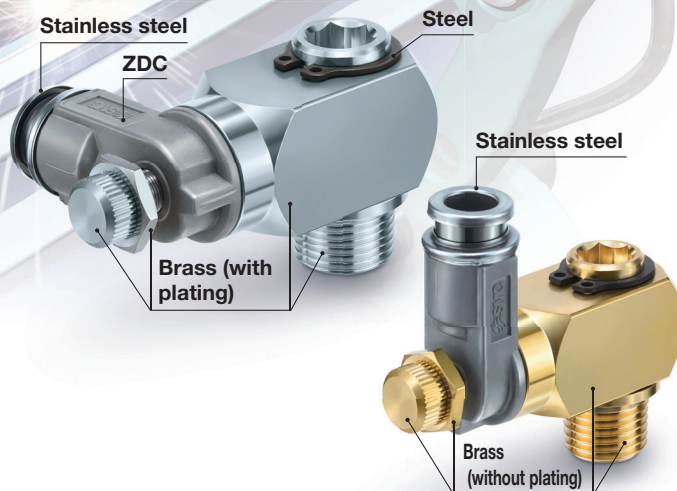
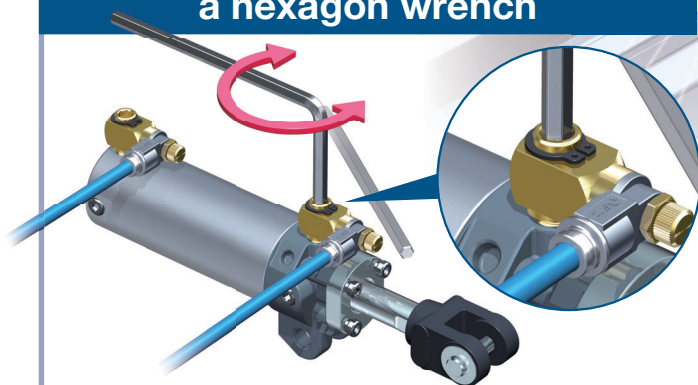

Improved piping design flexibility

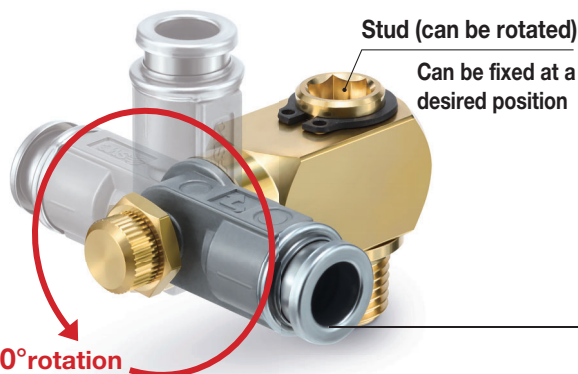

Reduced height when installed

Approx. **30 %** reduction
(when a knob is fully opened)

* 30.9 mm: ASB22□1-01-06 ▶ 21.2 mm: ASBL23□1-01-06

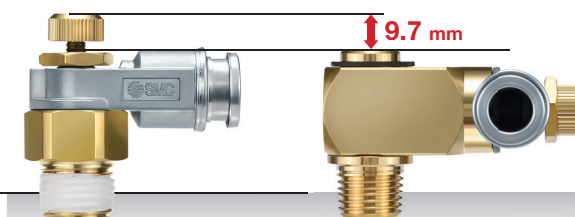

Variations

One-touch fitting type	Port size	Applicable tubing O.D.		
		Metric size	Inch size	
	M5 x 0.8	Ø 4, Ø 6	—	
	10-32UNF	—	Ø 5/32", Ø 1/4"	
	R NPT G	1/8	Ø 6, Ø 8	Ø 1/4", Ø 5/16"
		1/4	Ø 6, Ø 8, Ø 10	Ø 1/4", Ø 5/16", Ø 3/8"
		3/8	Ø 8, Ø 10	Ø 5/16", Ø 3/8"
	1/2	Ø 10, Ø 12	Ø 3/8", Ø 1/2"	

* Metric size: R, G only, Inch size: NPT only

Related equipment Spatter cover p. 5

Prevents adhesion and entry of
welding spatters

Made of flexible silicone rubber which conforms to the tube



* Option B (body without electroless nickel plating) is recommended for use in welding environments.

ASBL Series



CAT.EUS20-304A-UK

Metal Speed Controller / Low Profile Type **ASBL Series**



Model

Model*2	Port size	Seal method	Applicable tubing O.D.											
			Metric size (Applicable thread: R, G)					Inch size (Applicable thread: NPT)						
			4	6	8	10	12	5/32"	1/4"	5/16"	3/8"	1/2"		
ASBL13□1-M5-□	M5 x 0.8	Gasket seal	●	●										
ASBL13□1-U10/32-□	10-32UNF							●	●					
ASBL23□1-□01-□	R G NPT	Sealant (R/NPT)*1 Face seal (G)		●	●				●	●	●			
ASBL23□1-□02-□			1/8		●	●	●		●	●	●	●		
ASBL33□1-□03-□			1/4			●	●				●	●	●	
ASBL43□1-□04-□			3/8			●	●				●	●	●	
	1/2				●	●					●	●		

*1 "Without sealant" type can be selected as a standard option.

*2 Distinction between meter-out/meter-in types by appearance

Those are distinguished by the lock nut. The meter-out type is electroless nickel plated, while the meter-in type is black zinc chromate plated. (Excludes option B)

Specifications

Fluid	Air
Proof pressure	1.5 MPa
Max. operating pressure	1 MPa
Min. operating pressure	0.1 MPa
Ambient and fluid temperatures	-5 to 60 °C (No freezing)
Applicable tubing material*1, *2	FEP, PFA, Nylon, Soft nylon, Polyurethane, Polyolefin

*1 Check the maximum operating pressure of the tubing. (Please refer to the **catalogue on <https://www.smc.eu>** for details.)

*2 Tubing with inner layer of these materials is applicable.

SMC tubing: TRBU (FR double layer), TRTU (FR three-layer), TRS (FR soft nylon), etc.

Flow Rate and Sonic Conductance

Model		ASBL13□1-M5-□	ASBL23□1-□01-□	ASBL23□1-□02-□	ASBL33□1-□03-□	ASBL43□1-□04-□
Tubing O.D.	Metric size	∅ 4, ∅ 6	∅ 6, ∅ 8	∅ 6, ∅ 8, ∅ 10	∅ 8	∅ 10
	Inch size	∅ 5/32", ∅ 1/4"	∅ 1/4", ∅ 5/16"	∅ 1/4", ∅ 5/16", ∅ 3/8"	∅ 5/16"	∅ 3/8"
C values: Sonic conductance dm ³ /(s·bar)	Free flow	0.23	0.56	1.29	2.06	
	Controlled flow	0.25	0.55	1.07	2.08	2.32
b values: Critical pressure ratio	Free flow	0.3	0.2	0.25	0.2	
	Controlled flow	0.3	0.2	0.2	0.3	
Q[l/min (ANR)]*1	Free flow	58	134	318	493	
	Controlled flow	64	132	256	529	590

*1 These values have been calculated according to ISO 6358 and indicate the flow rate under standard conditions with an inlet pressure of 0.6 MPa (relative pressure) and a pressure drop of 0.1 MPa.

⚠ Caution

Be sure to read this before handling the products.
Refer to the back cover for safety instructions. For flow control equipment precautions, refer to the "Handling Precautions for SMC Products" and the "Operation Manual" on the SMC website: <https://www.smc.eu>

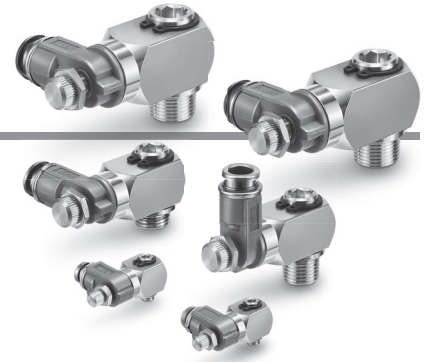

How to Order

ASBL 2 3 0 1 - [] 01 - 06 S B

Low profile type

Body size

1	M5 x 0.8 10-32UNF
2	1/8, 1/4
3	3/8
4	1/2

Universal

Control type

0	Meter-out
1	Meter-in

Thread type

—	R
N	NPT
G	G

Port size

M5	M5 x 0.8
U10/32	10-32UNF
01	1/8
02	1/4
03	3/8
04	1/2

Option

—	Electroless nickel plating
B	None

* If using in an environment with welding spatters, select option B "None" without electroless nickel plating to prevent spatters from getting stuck to the body.

Seal method

—	Without sealant
S	With sealant

* Select — (Without sealant) for M 5 , U10/32, and G thread.

Applicable tubing O.D.

Metric size

Inch size

04	∅ 4	03	∅ 5/32"
06	∅ 6	07	∅ 1/4"
08	∅ 8	09	∅ 5/16"
10	∅ 10	11	∅ 3/8"
12	∅ 12	13	∅ 1/2"

* For selecting applicable tubing O.D., refer to the "Model" on page 1.

ASBL Series

Flow Rate Characteristics

ASBL13□□-M5

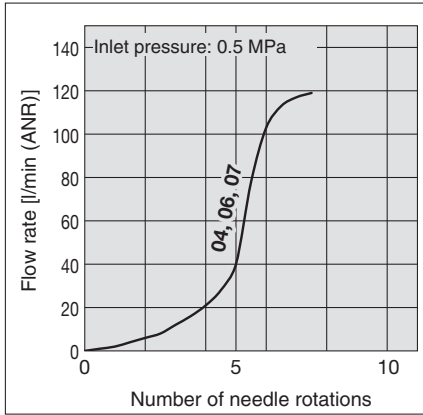

ASBL23□□-01

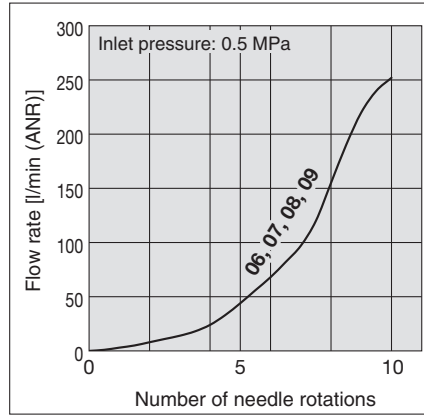

ASBL23□□-02

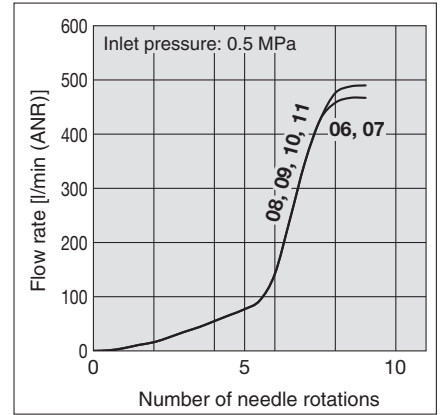

ASBL33□□-03

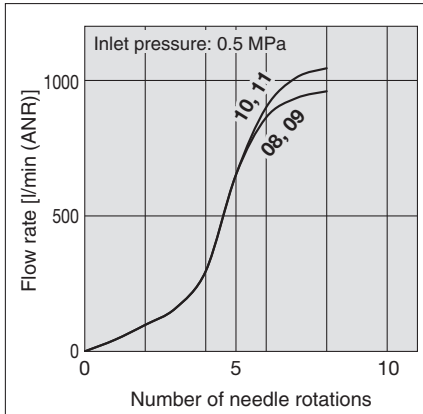

ASBL43□□-04

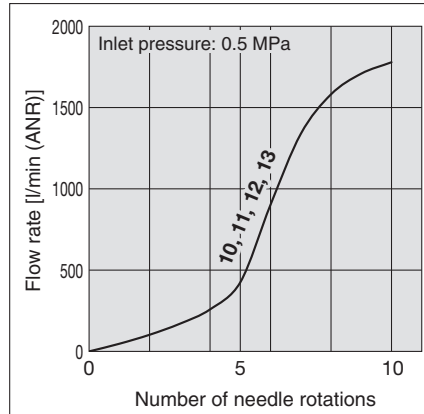

Metal Speed Controller / Low Profile Type **ASBL Series**

For M5, 10-32UNF, R, NPT thread

Dimensions

Seal method: Gasket seal
For M5

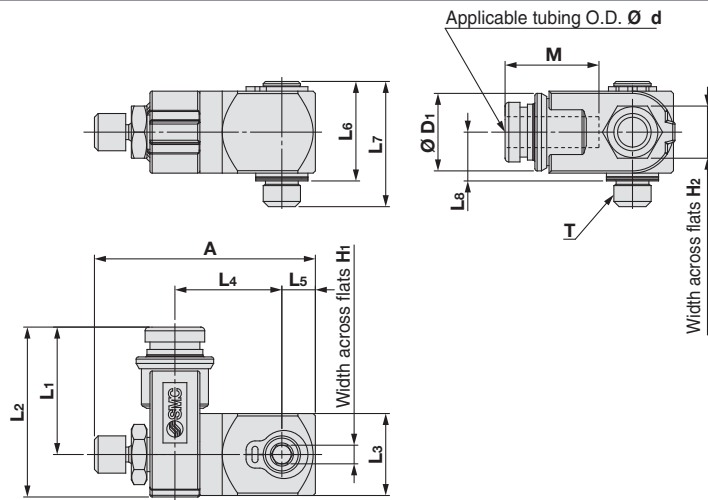

Metric Size

Model	Ø d	T	H ₁	H ₂	Ø D ₁	L ₁	L ₂	L ₃	L ₄	L ₅	L ₆	L ₇	L ₈	A		M
														Max.	Min.	
ASBL13□1-M5-04(B)	4	M5 x 0.8	2.5	7	10.4	17.1	22.8	11	14.4	4.5	13.4	16.8	6.6	32.7	29.7	12.6
ASBL13□1-M5-06(B)	6				13.1	20.8	26.5		13.2					13.6		

Inch Size

Model	Ø d	T	H ₁	H ₂	Ø D ₁	L ₁	L ₂	L ₃	L ₄	L ₅	L ₆	L ₇	L ₈	A		M
														Max.	Min.	
ASBL13□1-U10/32-03(B)	5/32"	10-32UNF	2.5	7	10.4	17.1	22.8	11	14.4	4.5	13.4	16.8	6.6	32.7	29.7	12.6
ASBL13□1-U10/32-07(B)	1/4"				13.1	20.8	26.5		13.2					13.5		

Seal method: Sealant
For R, NPT thread

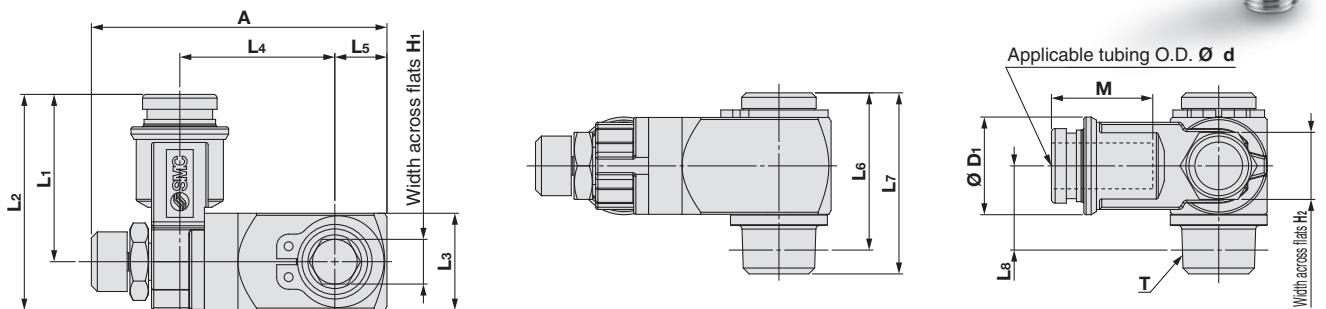

Metric Size

Model	Ø d	T	H ₁	H ₂	Ø D ₁	L ₁	L ₂	L ₃	L ₄	L ₅	L ₆	L ₇	L ₈	A		M
														Max.	Min.	
ASBL23□1-01-06□	6	R1/8	6	9	13.1	22.5	29	13	20.8	7	21.2	24.3	11.4	43.5	39.7	13.6
ASBL23□1-01-08□	8				15.1	25.4	31.9									16.1
ASBL23□1-02-06□	6	R1/4	8	12	13.1	24.7	33.2	17	27.7	9	27.9	32.6	16.1	53	48.6	16.1
ASBL23□1-02-08□	8				15.1	28.4	36.9									17
ASBL23□1-02-10□	10	R3/8	10	14	18	30.8	39.3	22	34.4	11	33.6	38.7	19.1	64	59.4	17
ASBL33□1-03-08□	8				15.1	30	41									17
ASBL33□1-03-10□	10	R1/2	10	17	18	32.1	43.1	27	40.4	13.5	41.2	47.6	24.2	75.3	70.2	17
ASBL43□1-04-10□	10				18	34.4	47.9									17
ASBL43□1-04-12□	12				21	36.3	49.8									18.6

Inch Size

Model	Ø d	T	H ₁	H ₂	Ø D ₁	L ₁	L ₂	L ₃	L ₄	L ₅	L ₆	L ₇	L ₈	A		M
														Max.	Min.	
ASBL23□1-N01-07□	1/4"	NPT1/8	7/32"	9	13.1	22.5	29	13	20.8	7	21.1	24.3	11.3	43.5	39.7	13.5
ASBL23□1-N01-09□	5/16"				15.1	25.4	31.9									16.1
ASBL23□1-N02-07□	1/4"	NPT1/4	5/16"	12	13.1	24.7	33.2	17	27.7	9	28.2	32.6	16.4	53	48.6	16.1
ASBL23□1-N02-09□	5/16"				15.1	28.4	36.9									17
ASBL23□1-N02-11□	3/8"	NPT3/8	3/8"	14	18	30.8	39.3	22	34.4	11	34	38.7	19.5	64	59.4	16.6
ASBL33□1-N03-09□	5/16"				15.1	30	41									17
ASBL33□1-N03-11□	3/8"	NPT1/2	3/8"	17	18	32.1	43.1	27	40.4	13.5	41.2	47.6	24.2	75.3	70.2	16.6
ASBL43□1-N04-11□	3/8"				18	34.4	47.9									17
ASBL43□1-N04-13□	1/2"				21	36.3	49.8									18.5

ASBL Series

For G thread

Dimensions

Seal method: Face seal
For G thread

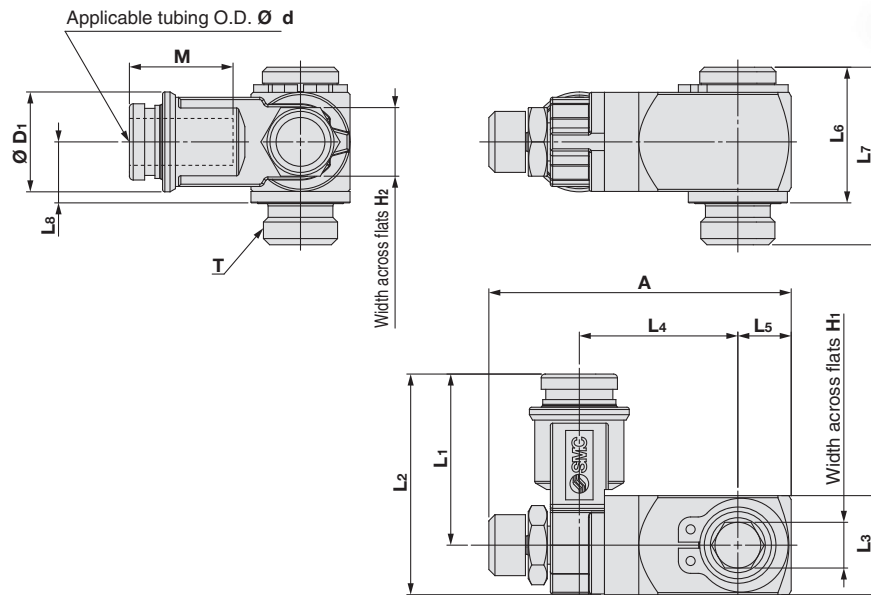

Metric Size

[mm]

Model	Ø d	T	H ₁	H ₂	Ø D ₁	L ₁	L ₂	L ₃	L ₄	L ₅	L ₆	L ₇	L ₈	A		M
														Max.	Min.	
ASBL23□1-G01-06□	6	G1/8	6	9	13.1	22.5	29	13	20.8	7	17.8	23.3	8	43.5	39.7	13.6
ASBL23□1-G01-08□	8				15.1	25.4	31.9									16.1
ASBL23□1-G02-06□	6	G1/4	8	12	13.1	24.7	33.2	17	27.7	9	22.1	28.6	10.3	53	48.6	13.6
ASBL23□1-G02-08□	8				15.1	28.4	36.9									16.1
ASBL23□1-G02-10□	10				18	30.8	39.3									17
ASBL33□1-G03-08□	8	G3/8	10	14	15.1	30	41	22	34.4	11	27.8	35.3	13.3	64	59.4	16.1
ASBL33□1-G03-10□	10				18	32.1	43.1									17
ASBL43□1-G04-10□	10	G1/2	10	17	18	34.4	47.9	27	40.4	13.5	33.5	42.5	16.6	75.3	70.2	17
ASBL43□1-G04-12□	12				21	36.3	49.8									18.6

Related Equipment

Spatter cover

Applicable tubing: FR soft nylon/TRS, FR double layer/TRB/TRBU, FR three-layer/TRTU



Sales unit: 10 pcs./bag

Model	Applicable tubing O.D.	L ₁	L ₂	Ø D ₁	Ø D ₂
KQB2-06C-X1124	6	24.6	16.6	13.5	11.6
KQB2-08C-X1124	8	30.2	20.6	16.4	14.2
KQB2-10C-X1124	10	34.4	24.6	19.3	16.2

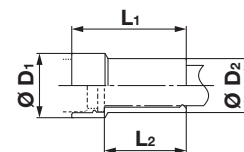

- * Since the spatter cover is designed for multi-layer (double layer, three-layer) tubing, sufficient effects cannot be obtained in foreign matter flow-in or followability for single-layer tubing.
- * The cover can be attached regardless of the single-layer/multi-layer tubing.

Can also be used for the KQB2/KQG2 series

* Cannot be used for union "Y" (KQBU□/KQG2U) 2-port side



Metal
One-touch Fittings
KQB2 Series



Stainless Steel 316
One-touch Fittings
KQG2 Series



ASBL Series

Specific Product Precautions

Be sure to read this before handling the products. Refer to the back cover for safety instructions. For flow control equipment precautions, refer to the “Handling Precautions for SMC Products” and the “Operation Manual” on the SMC website: <https://www.smc.eu>

Design and Selection

Warning

1. Confirm the specifications.

The products in this catalogue are designed to be used in compressed air systems (including vacuum) only. If the products are used in an environment where pressure or temperature is out of the specified range, damage and/or malfunction may result. Do not use under such conditions. (Refer to the specifications.)

Please contact SMC when using a fluid other than compressed air (including vacuum).

We do not guarantee against any damage if the product is used outside of the specification range.

2. Products mentioned in this catalogue are not designed for use as stop valves with zero air leakage.

A certain amount of leakage is allowed in the product's specifications. Tightening the needle to reduce leakage to zero may result in equipment damage.

3. Do not disassemble the product or make any modifications, including additional machining.

Doing so may cause human injury and/or an accident.

4. The flow rate characteristics for each product are representative values.

The flow rate characteristics are characteristics of each individual product. Characteristics varies depending on piping, circuit, and pressure requirements. In addition, the product may not have flow from the fully closed to 1 rotation position, but this is not a flow rate error. Also, depending on product specifications, there may be variations in the zero needle rotation position flow rate characteristics.

5. Sonic conductance (C) and critical pressure ratio (b) values for products are representative values.

For controlled flow direction values the needle is fully open. For free flow direction values the needle is fully closed.

6. Check if PTFE can be used in the application.

PTFE powder (Polytetrafluoroethylene resin) is included in the seal material of the male thread type piping taper thread. Confirm that the use of it will not cause any adverse effects on the system.

Please contact SMC if the Material Safety Data Sheet (MSDS) is required.

7. Speed controllers are designed to control the speed of the actuator.

Mounting

Warning

1. Confirm that the lock nut is tightened.

After adjusting a cylinder speed, make sure that the lock nut is securely tightened and the needle is locked. A loose lock nut may cause speed changes in the actuator. Excessive tightening of the lock nut may damage the product, so please tighten with the proper tightening torque.

Mounting

Warning

2. Confirm the air flow direction.

Mounting backward is dangerous because the speed adjustment needle will not work, and the actuator may lurch suddenly.

3. Adjust the needle by opening the needle slowly after having closed it completely.

Loose needle valves may cause unexpected sudden actuator extension.

When the needle valve is turned clockwise, it is closed and the cylinder speed decreases. When turned counterclockwise, it is open and the cylinder speed increases. If an excessive torque is applied, the components may be damaged.

Flow Direction Symbols on Body

	Meter-out	Meter-in
Indication symbol		

4. Insert a proper hexagon wrench key into the hexagon socket of the stud, ensuring it is inserted fully before rotating, for when mounting or removing the product.

Do not apply torque at other points, as the product may be damaged. Rotate the end body manually for positioning after installation.

* Shape of a hexagon wrench key conforms to JIS B 4609 2008.

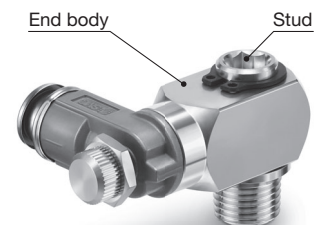

5. Rotation for positioning after threading into the port is possible, but it cannot be used while rotation and oscillating.

Fluid may be contaminated with metallic dust due to wear, and lead to air leakage.

6. If the connection tube oscillates or turns, do not use this product.

If body A has a possibility that it may oscillate or turn during operation, use the product with a fixed tube, otherwise the product body or fitting parts may be damaged.

Safety Instructions

These safety instructions are intended to prevent hazardous situations and/or equipment damage. These instructions indicate the level of potential hazard with the labels of “Caution,” “Warning” or “Danger.” They are all important notes for safety and must be followed in addition to International Standards (ISO/IEC) ¹⁾, and other safety regulations.

Danger:

Danger indicates a hazard with a high level of risk which, if not avoided, will result in death or serious injury.

Warning:

Warning indicates a hazard with a medium level of risk which, if not avoided, could result in death or serious injury.

Caution:

Caution indicates a hazard with a low level of risk which, if not avoided, could result in minor or moderate injury.

- 1) ISO 4414: Pneumatic fluid power – General rules and safety requirements for systems and their components.
- ISO 4413: Hydraulic fluid power – General rules and safety requirements for systems and their components.
- IEC 60204-1: Safety of machinery – Electrical equipment of machines. (Part 1: General requirements)
- ISO 10218-1: Robots and robotic devices - Safety requirements for industrial robots - Part 1: Robots.
- etc.

Warning

1. The compatibility of the product is the responsibility of the person who designs the equipment or decides its specifications.

Since the product specified here is used under various operating conditions, its compatibility with specific equipment must be decided by the person who designs the equipment or decides its specifications based on necessary analysis and test results. The expected performance and safety assurance of the equipment will be the responsibility of the person who has determined its compatibility with the product. This person should also continuously review all specifications of the product referring to its latest catalogue information, with a view to giving due consideration to any possibility of equipment failure when configuring the equipment.

2. Only personnel with appropriate training should operate machinery and equipment.

The product specified here may become unsafe if handled incorrectly. The assembly, operation and maintenance of machines or equipment including our products must be performed by an operator who is appropriately trained and experienced.

3. Do not service or attempt to remove product and machinery/equipment until safety is confirmed.

1. The inspection and maintenance of machinery/equipment should only be performed after measures to prevent falling or runaway of the driven objects have been confirmed.
2. When the product is to be removed, confirm that the safety measures as mentioned above are implemented and the power from any appropriate source is cut, and read and understand the specific product precautions of all relevant products carefully.
3. Before machinery/equipment is restarted, take measures to prevent unexpected operation and malfunction.

4. Our products cannot be used beyond their specifications. Our products are not developed, designed, and manufactured to be used under the following conditions or environments.

Use under such conditions or environments is not covered.

1. Conditions and environments outside of the given specifications, or use outdoors or in a place exposed to direct sunlight.
2. Use for nuclear power, railways, aviation, space equipment, ships, vehicles, military application, equipment affecting human life, body, and property, fuel equipment, entertainment equipment, emergency shut-off circuits, press clutches, brake circuits, safety equipment, etc., and use for applications that do not conform to standard specifications such as catalogues and operation manuals.
3. Use for interlock circuits, except for use with double interlock such as installing a mechanical protection function in case of failure. Please periodically inspect the product to confirm that the product is operating properly.

Caution

We develop, design, and manufacture our products to be used for automatic control equipment, and provide them for peaceful use in manufacturing industries.

Use in non-manufacturing industries is not covered.

Products we manufacture and sell cannot be used for the purpose of transactions or certification specified in the Measurement Act.

The new Measurement Act prohibits use of any unit other than SI units in Japan.

Limited warranty and Disclaimer/Compliance Requirements

The product used is subject to the following “Limited warranty and Disclaimer” and “Compliance Requirements”. Read and accept them before using the product.

Limited warranty and Disclaimer

1. The warranty period of the product is 1 year in service or 1.5 years after the product is delivered, whichever is first. ²⁾ Also, the product may have specified durability, running distance or replacement parts. Please consult your nearest sales branch.
2. For any failure or damage reported within the warranty period which is clearly our responsibility, a replacement product or necessary parts will be provided. This limited warranty applies only to our product independently, and not to any other damage incurred due to the failure of the product.
3. Prior to using SMC products, please read and understand the warranty terms and disclaimers noted in the specified catalogue for the particular products.
- 2) Vacuum pads are excluded from this 1 year warranty.
A vacuum pad is a consumable part, so it is warranted for a year after it is delivered. Also, even within the warranty period, the wear of a product due to the use of the vacuum pad or failure due to the deterioration of rubber material are not covered by the limited warranty.

Compliance Requirements

1. The use of SMC products with production equipment for the manufacture of weapons of mass destruction (WMD) or any other weapon is strictly prohibited.
2. The exports of SMC products or technology from one country to another are governed by the relevant security laws and regulations of the countries involved in the transaction. Prior to the shipment of a SMC product to another country, assure that all local rules governing that export are known and followed.

Safety Instructions

Be sure to read “Handling Precautions for SMC Products” (M-E03-3) before using.

SMC Corporation (Europe)

Austria	+43 (0)2262622800	www.smc.at	office@smc.at
Belgium	+32 (0)33551464	www.smc.be	info@smc.be
Bulgaria	+359 (0)2807670	www.smc.bg	office@smc.bg
Croatia	+385 (0)13707288	www.smc.hr	office@smc.hr
Czech Republic	+420 541424611	www.smc.cz	office@smc.cz
Denmark	+45 70252900	www.smc.dk.com	smc@smcdk.com
Estonia	+372 651 0370	www.smcee.ee	info@smcee.ee
Finland	+358 207513513	www.smc.fi	smc.fi@smc.fi
France	+33 (0)164761000	www.smc-france.fr	supportclient@smc-france.fr
Germany	+49 (0)61034020	www.smc.de	info@smc.de
Greece	+30 210 2717265	www.smchellas.gr	sales@smchellas.gr
Hungary	+36 23513000	www.smc.hu	office@smc.hu
Ireland	+353 (0)14039000	www.smcautomation.ie	sales@smcautomation.ie
Italy	+39 03990691	www.smcitalia.it	mailbox@smcitalia.it
Latvia	+371 67817700	www.smc.lv	info@smc.lv

Lithuania	+370 5 2308118	www.smclt.lt	info@smclt.lt
Netherlands	+31 (0)205318888	www.smc.nl	info@smc.nl
Norway	+47 67129020	www.smc-norge.no	post@smc-norge.no
Poland	+48 222119600	www.smc.pl	sales@smc.pl
Portugal	+351 214724500	www.smc.eu	apoioclientept@smc.smces.es
Romania	+40 213205111	www.smcromania.ro	smcromania@smcromania.ro
Russia	+7 (812)3036600	www.smc.eu	sales@smcru.com
Slovakia	+421 (0)413213212	www.smc.sk	office@smc.sk
Slovenia	+386 (0)73885412	www.smc.si	office@smc.si
Spain	+34 945184100	www.smc.eu	post@smc.smces.es
Sweden	+46 (0)86031240	www.smc.nu	smc@smc.nu
Switzerland	+41 (0)523963131	www.smc.ch	info@smc.ch
Turkey	+90 212 489 0 440	www.smcturkey.com.tr	info@smcturkey.com.tr
UK	+44 (0)845 121 5122	www.smc.uk	sales@smc.uk

South Africa +27 10 900 1233 www.smcza.co.za zasales@smcza.co.za