

Speed Controller with One-touch Fitting for Clean Room Series **AS-FPQ/AS-FPG**

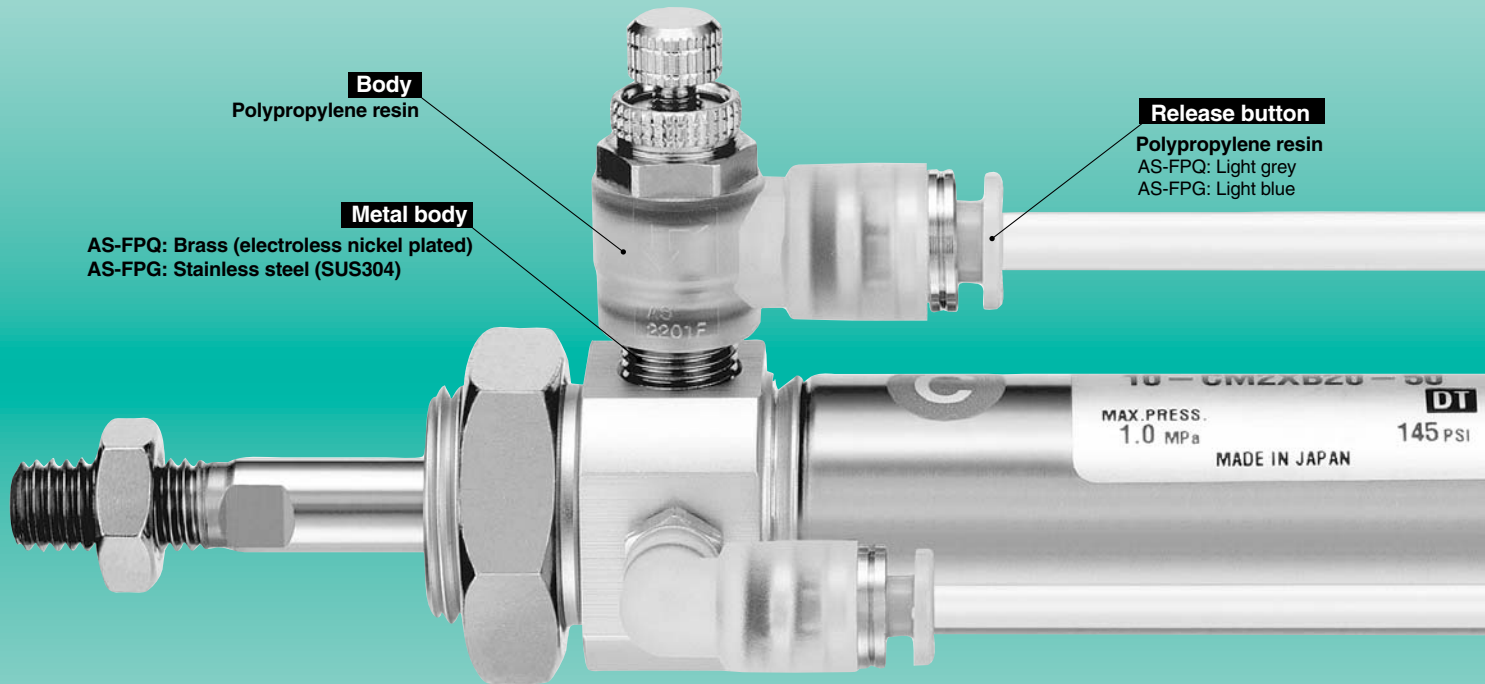

**AS-FPQ: Brass (electroless nickel plated) and
AS-FPG: Stainless steel (SUS304) are now available as a series.**

Low particulate generating speed controllers designed for use in clean rooms



Speed Controller with One-touch Fitting for Clean Room

Series AS-FPQ/FPG

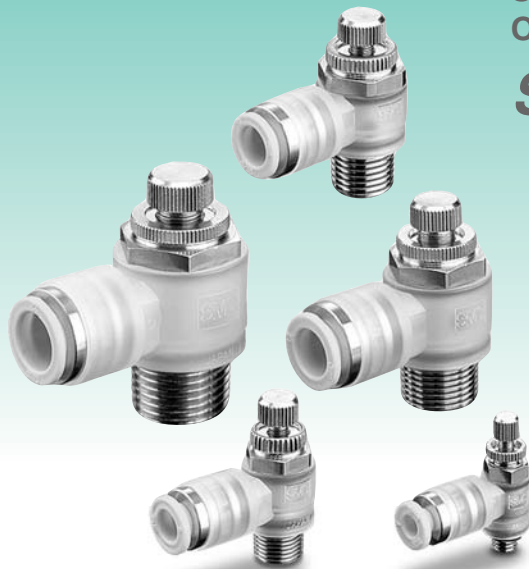

Series AS-FPQ
Brass (electroless nickel plated)

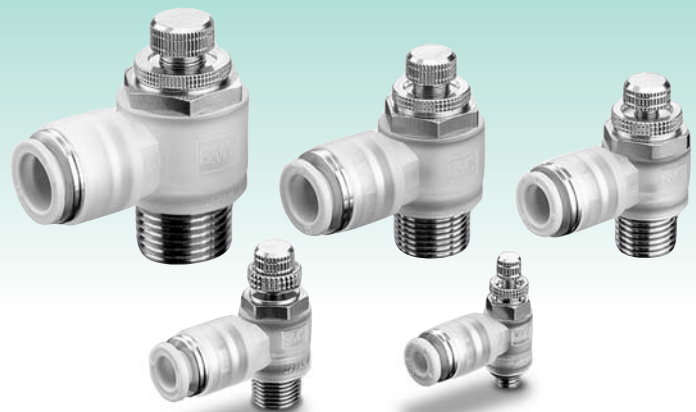

Series AS-FPG
Stainless steel (SUS304)

Elbow type	Port size	Applicable tube O.D. (mm)					Applicable cylinder bore size (mm)
		4	6	8	10	12	
AS12□1FP□-M5	M5 x 0.8	●	●	●	●	●	6, 10, 16, 20
AS22□1FP□-01	R 1/8	●	●	●	●	●	20, 25, 32
AS22□1FP□-02	R 1/4	●	●	●	●	●	20, 25, 32, 40
AS32□1FP□-03	R 3/8	●	●	●	●	●	40, 50, 63
AS42□1FP□-04	R 1/2	●	●	●	●	●	63, 80, 100

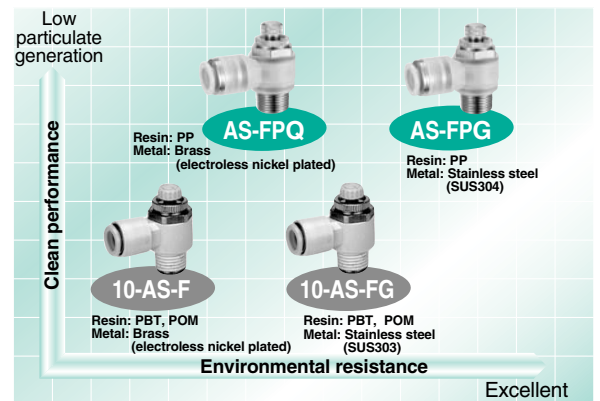

Speed Controller with One-touch Fitting for Clean Room

Elbow Type

Series AS-FPQ/FPG

AS-FPQ/Brass (electroless nickel plated)

Release button colour: Light grey



AS-FPG/Stainless steel (SUS304)

Release button colour: Light blue



Models

Elbow type	Port size	Applicable tubing O.D. (mm)					Applicable cylinder bore size (mm)
		4	6	8	10	12	
AS12□1FP□-M5	M5 x 0.8	●	●				6, 10, 16, 20
AS22□1FP□-01	R 1/8	●	●	●			20, 25, 32
AS22□1FP□-02	R 1/4	●	●	●	●		20, 25, 32, 40
AS32□1FP□-03	R 3/8		●	●	●	●	40, 50, 63
AS42□1FP□-04	R 1/2				●	●	63, 80, 100

Specifications

Particulate generation grade	Grade 1 ^{Note 1)}
Proof pressure	1.5MPa ^{Note 2)}
Maximum operating pressure	1MPa ^{Note 3)}
Minimum operating pressure	0.1MPa
Ambient and fluid temperature	-5 to 60°C (with no freezing)
Number of needle rotations	10 rotations (8 rotations ^{Note 4)})
Oil	Fluorine-based grease

Note 1) Refer to particulate generation grade classifications.

Note 2) Proof pressure is 1.5 times higher than maximum operating pressure.

Note 3) The value of the maximum operating pressure is at a temperature of 20°C. In other cases, refer to "Relationship between Operating Temperature and Max. Operating Pressure" below.

Note 4) For AS12□1FP□

Flow Rate and Effective Area

Model		AS12□1FP□-M5	AS22□1FP□-01	AS22□1FP□-02	AS32□1FP□-03	AS42□1FP□-04
Tubing O.D.	Metric sizes	ø4	ø4 ø6	ø4 ø6 ø8	ø6 ø8 ø10	ø10 ø12
		ø6	ø8	ø10	ø12	
Controlled (free) flow	Flow rate ℓ/min (ANR)	100	180 230	260 390 460	660 790 920	1580 1710
	Effective area mm^2	1.5	2.7 3.5	4 6 7	10 12 14	24 26

Note) Flow rate values are at a pressure of 0.5MPa, and temperature of 20°C.

Recommended Applicable Tubing

Tubing material	Clean series polyurethane tubing: Series 10
Tubing O.D.	ø4, ø6, ø8, ø10, ø12

Polyurethane tubing: Series TU, Nylon tubing: Series T and Soft nylon tubing: Series TS can also be used. However, the degree of clean performance will decline.

Particulate Generation Grade Classifications

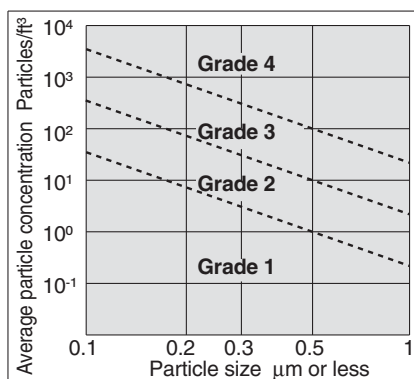

Relation of Operating Temperature and Maximum Operating Pressure

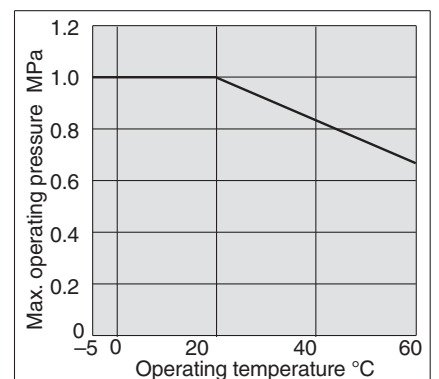

JIS symbol

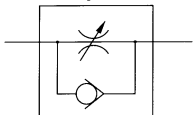

Flow direction symbols on body

	Meter-out type	Meter-in type
Symbol		
JIS symbol		

Series AS-FPQ/FPG

How to Order

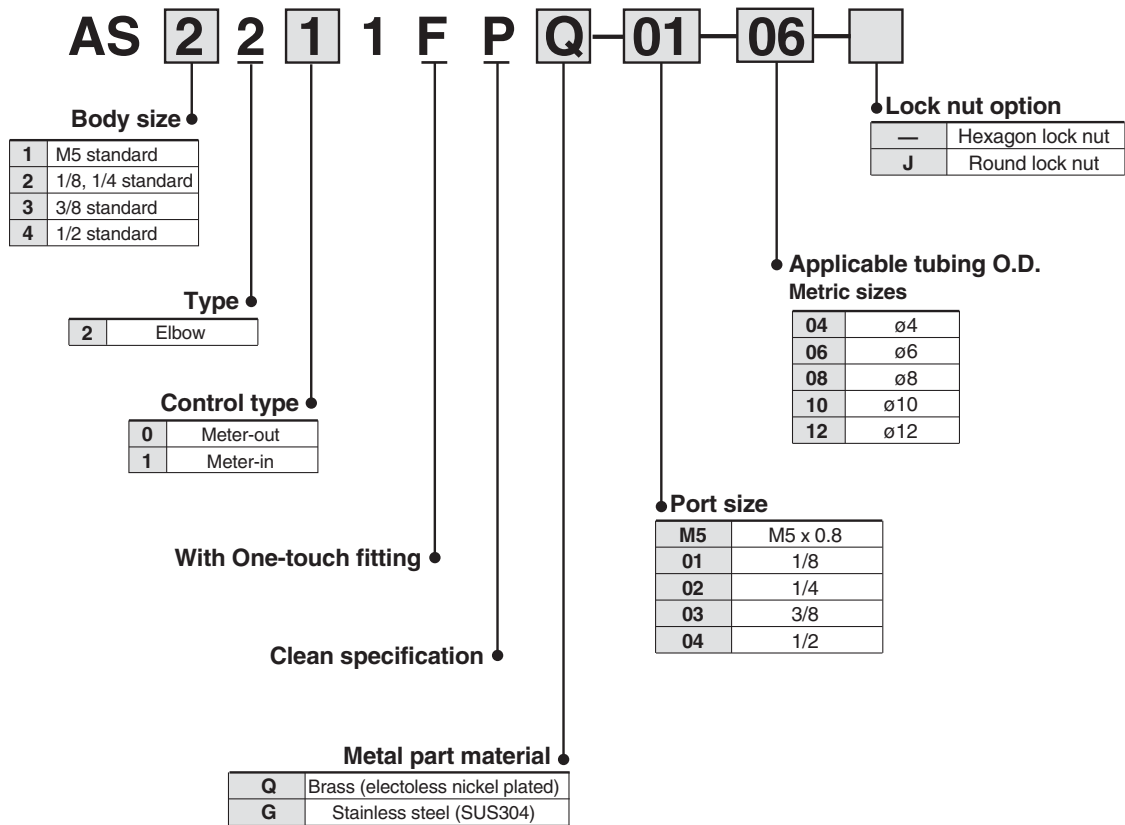

Needle Valve/Flow Characteristics

AS12□1FP□-M5

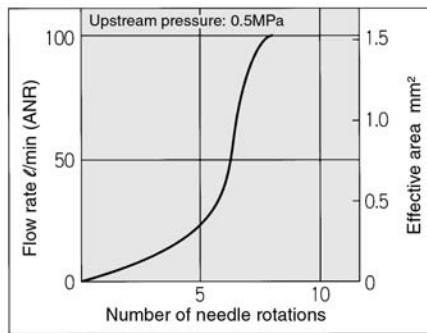

AS22□1FP□-01

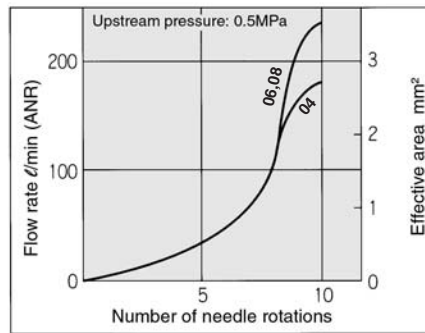

AS22□1FP□-02

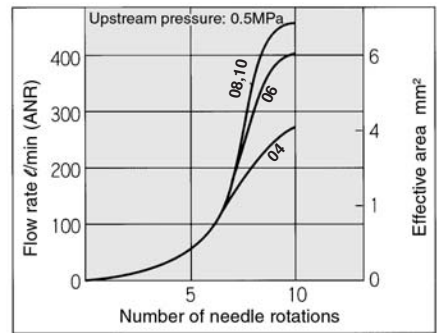

AS32□1FP□-03

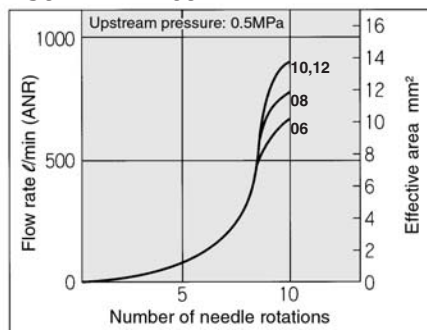

AS42□1FP□-04

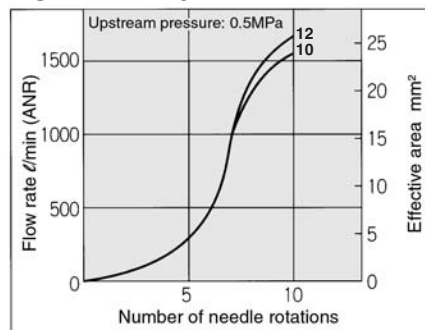

Construction

Meter-out type M5 type

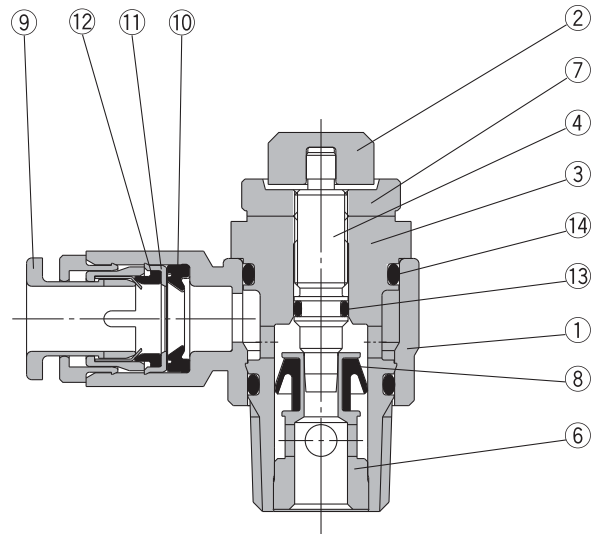
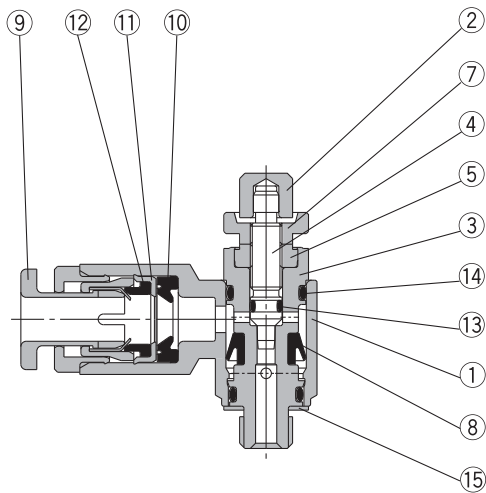

Meter-in type M5 type

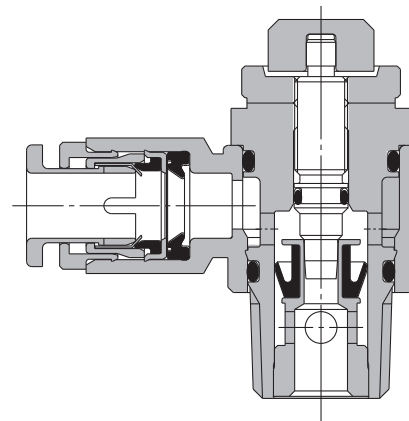
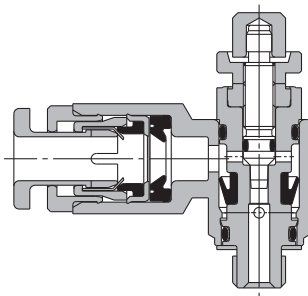

Parts list

No.	Description	AS□□□1FPQ		AS□□□1FPG	
		Material	Note	Material	Note
1	Body A	Polypropylene resin		Polypropylene resin	
2	Knob	Brass	Electroless nickel plated	SUS304	
3	Body B	Brass	Electroless nickel plated	SUS304	
4	Needle	Brass	Electroless nickel plated	SUS304	
5	Needle guide	Brass	Electroless nickel plated	SUS304	
6	Seat ring	Brass	Electroless nickel plated	SUS304	
7	Lock nut	Steel	Electroless nickel plated	SUS304	
8	U seal	HNBR		HNBR	
9	Cassette	Polypropylene resin SUS304, Brass	Brass parts are electroless nickel plated	Polypropylene resin SUS304	
10	Seal	NBR		NBR	
11	Stopper	SUS304		SUS304	
12	Cushion	NBR		NBR	
13	O-ring	NBR		NBR	
14	O-ring	NBR		NBR	
15	Gasket	NBR, SUS304		NBR, SUS304	

SUS304: SUS304 Stainless steel

Series AS-FPQ/FPG

Dimensions

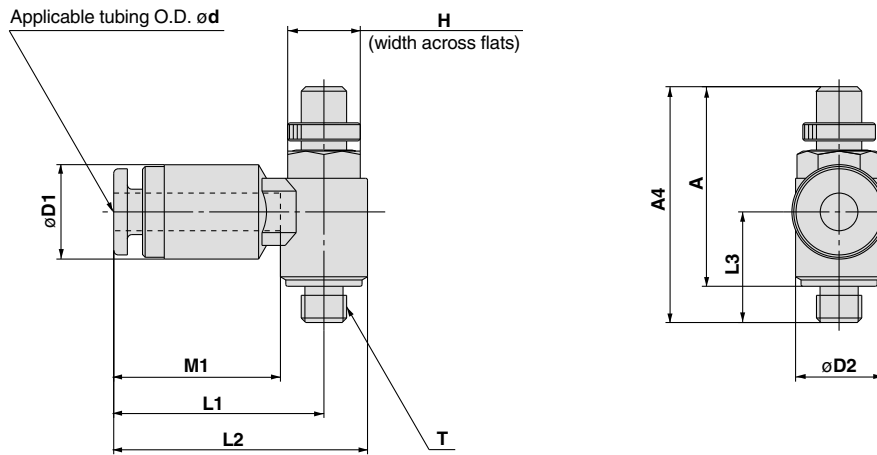
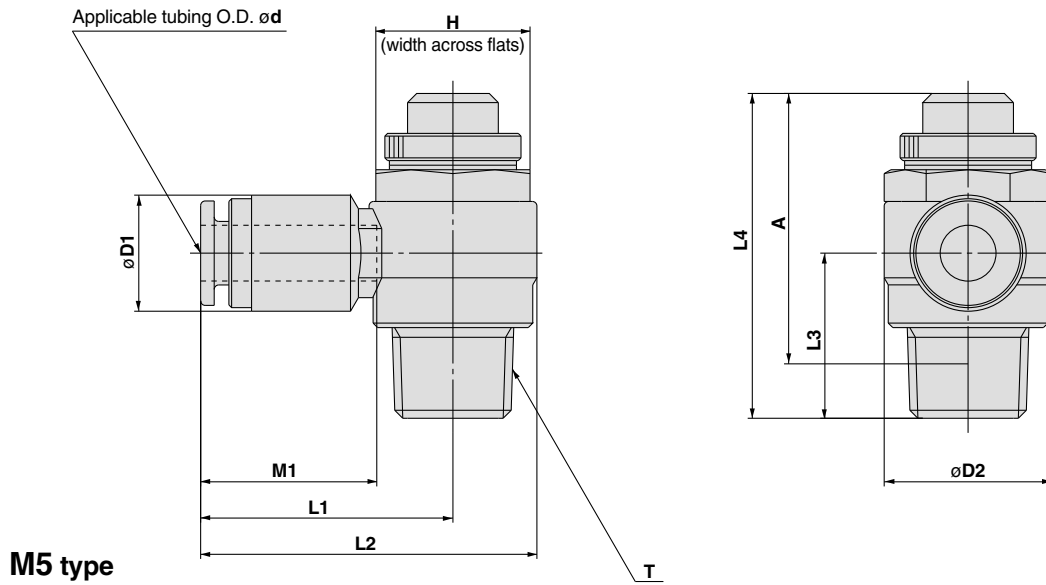

Model	Tubing O.D. d	T	H	D1	D2	L1	L2	L3	L4		A Note 1)		M1	Weight (g) Note 2)	
									Max.	Min.	Max.	Min.		1*	2*
AS12□1FP□-M5-04	4	M5 x 0.8	8	10.4	9.6	23.2	28	12.2	28.3	25.5	25	22.2	18.4	7	7
AS12□1FP□-M5-06	6			12.8		29	19.4						8	8	
AS22□1FP□-01-04	4	R 1/8	12	10.4	14.2	25.3	32.4	14.3	36.4	31.4	32.4	27.4	18.4	17	17
AS22□1FP□-01-06	6			12.8		33.4	19.4						18	18	
AS22□1FP□-01-08	8			15.2		35.6	21.9						20	20	
AS22□1FP□-02-04	4	R 1/4	17	10.4	18.5	27.8	37	18.2	40.8	35.8	34.8	29.8	18.4	33	33
AS22□1FP□-02-06	6			12.8		37	19.4						33	33	
AS22□1FP□-02-08	8			15.2		39.6	21.9						35	35	
AS22□1FP□-02-10	10			18.5		47.5	23.8						38	38	
AS32□1FP□-03-06	6	R 3/8	19	12.8	23	30.4	41.9	20.9	46.9	41.9	40.6	35.6	19.4	59	55
AS32□1FP□-03-08	8			15.2		44.4	21.9						61	57	
AS32□1FP□-03-10	10			18.5		46.1	23.8						63	59	
AS32□1FP□-03-12	12			20.9		47.3	25						65	61	
AS42□1FP□-04-10	10	R 1/2	24	18.5	28.6	36.6	50.9	25.4	55.6	50.6	47.4	42.4	23.8	107	100
AS42□1FP□-04-12	12			20.9		52.5	25						109	102	

Note 1) Reference dimension for threads after installation

Note 2) 1* is the weight for type AS□2□1FPQ (brass + electroless nickel plated), 2* is the weight for type AS□2□1FPG (SUS304).



Series AS-FPQ/FPG Safety Instructions

These safety instructions are intended to prevent a hazardous situation and/or equipment damage. These instructions indicate the level of potential hazard by a label of "**Caution**", "**Warning**" or "**Danger**". To ensure safety, be sure to observe ISO 4414 Note 1), JIS B 8370 Note 2) and other safety practices.

 **Caution** : Operator error could result in injury or equipment damage.

 **Warning** : Operator error could result in serious injury or loss of life.

 **Danger** : In extreme conditions, there is a possible result of serious injury or loss of life.

Note 1) ISO 4414: Pneumatic fluid power – Recommendations for the application of equipment to transmission and control systems

Note 2) JIS B 8370: General Rules for Pneumatic Equipment

Warning

1. The compatibility of pneumatic equipment is the responsibility of the person who designs the pneumatic system or decides its specifications.

Since the products specified here are used in various operating conditions, their compatibility for the specific pneumatic system must be based on specifications or after analysis and/or tests to meet your specific requirements.

2. Only trained personnel should operate pneumatically operated machinery and equipment.

Compressed air can be dangerous if handled incorrectly. Assembly, handling or repair of pneumatic systems should be performed by trained and experienced operators.

3. Do not service machinery/equipment or attempt to remove components until safety is confirmed.

1. Inspection and maintenance of machinery/equipment should only be performed after confirmation of safe locked-out control positions.
2. When equipment is to be removed, confirm the safety process as mentioned above. Cut the supply pressure and electric power for this equipment and exhaust all compressed air in the system.
3. Before machinery/equipment is restarted, take measures to prevent shooting-out of cylinder piston rod, etc. (Bleed air into the system gradually to create back pressure.)

4. Contact SMC if the product is to be used in any of the following conditions:

1. Conditions and environments beyond the given specifications, or if product is used outdoors.
2. Installation on equipment in conjunction with atomic energy, railway, air navigation, vehicles, medical equipment, food and beverages, recreation equipment, emergency stop circuits, press applications, or safety equipment.
3. An application which has the possibility of having negative effects on people, property, or animals, requiring special safety analysis.



Series AS-FPQ/FPG Specific Product Precautions 1

Be sure to read before handling.

Selection

⚠ Warning

1. Confirm the specifications.

The products appearing in this catalogue are designed for use only in compressed air systems.

Do not use outside the specified ranges of pressure, temperature, etc., as this may cause damage or malfunction. (Refer to specifications.)

Consult SMC if fluids other than compressed air are to be used.

2. This product cannot be used as a stop valve requiring zero air leakage.

A certain amount of leakage is allowed in the product's specifications.

Handling

⚠ Caution

1. Store away from direct sunlight at 40°C or less.
2. Open the inner package of the double packaging in a clean room or other clean environment.

Installation and Adjustment

⚠ Warning

1. Allow space for maintenance.

Allow the space necessary for maintenance and inspections

2. Tighten screws with the proper tightening torque.

When mounting the product, tighten screws with the recommended torque.

3. Install and remove by tightening or loosening the hexagon wrench flats on Body B with a suitable wrench.

Damage may occur if any other part is used. Adjustment of the position after mounting should be performed by turning Body A by hand.

4. Confirm that the lock nut is not loose.

If the lock nut is loose, there may be dangerous changes in actuator speed

5. The number of opening and closing rotations of the needle valve should be adjusted within the range of the specifications.

Since it has a pull-out stop mechanism, it will not rotate past the limit. Confirm the number of rotations for the product being used, as excessive turning of the needle will cause damage.

6. Mount after confirming the direction of flow.

Mounting backwards is dangerous, because the speed adjustment needle will not work and the actuator may lurch suddenly.

7. To adjust the speed, start with the needle in the completely closed position, and then adjust by opening gradually.

When the needle valve is opening, the actuator may lurch suddenly creating a dangerous situation.

Moreover, the needle valve is closed by turning clockwise, and opened by turning counterclockwise. Therefore, the actuator speed is reduced by turning clockwise and increased by turning counterclockwise.

Installation and Adjustment

⚠ Caution

1. Before mounting confirm the model and size, etc. Also confirm that there are no scratches, nicks or cracks in the product.
2. When tubing is connected, consider factors such as changes in the tubing length due to pressure, and allow sufficient leeway.
3. Mount so that fittings and tubing are not subjected to twisting, pulling or moment loads. This can cause damage to fittings and flattening, bursting or disconnection of tubing, etc.

Piping

⚠ Caution

1. Preparation before piping

Before piping is connected, it should be thoroughly blown out with air (flushing) or washed to remove chips, cutting oil and other debris from inside the pipe.

2. Be sure to wrap sealant tape around the taper threads. Using without sealant tape can cause air leakage.

3. Wrapping of sealant tape

When screwing together pipes, fittings, etc., be certain that chips from the pipe threads and sealant material do not get inside the piping.

Further, when sealant tape is used, leave 1.5 to 2 thread ridges exposed at the end of the threads

Tightening Torque

⚠ Caution

1. The proper tightening torque for pipe fittings is as shown in the table. As a rule, they should be tightened 2 to 3 turns with a tool after first tightening by hand.

Furthermore, over-tightening can cause air leakage due to broken threads and deformation of the gasket, etc. Under-tightening can cause loose threads and air leakage, etc.

Male thread	Proper tightening torque N·m	Width across flats mm	Nominal size of adjustable angle wrench mm
M5	1/6 turn after hand tightening	8	100
1/8	7 to 9	12	150
1/4	12 to 14	17	200
3/8	22 to 24	19	200
1/2	28 to 30	24	200

Lock Nut Tightening Torque

⚠ Caution

1. The proper tightening torque for the hexagon lock nut is as shown in the table. As a rule, it should be tightened an additional 15 to 30° with a tool after first tightening by hand. Be careful not to cause damage by over tightening.

Body size	Proper tightening torque N·m
M5	0.3
1/8	1
1/4	1.5
3/8	4
1/2	10



Series AS-FPQ/FPG Specific Product Precautions 2

Be sure to read before handling.

Installation and Removal of Tubing

⚠ Caution

1. Installation of tubing
 - 1) Using tube cutters TK-1, 2 or 3, take a tube having no flaws on its periphery and cut it off at a right angle. Do not use pinchers, nippers or scissors, etc. The tubing might be cut diagonally or flattened, making installation impossible or causing problems such as disconnection and leakage.
 - 2) Hold the tube and push it in slowly, inserting it securely all the way into the fitting.
 - 3) After inserting the tubing, pull on it lightly to confirm that it will not come out. If it is not installed securely all the way into the fitting, problems such as leakage or disconnection of the tubing can occur.
2. Removal of tubing
 - 1) Push in the release button sufficiently, pressing the collar evenly around its circumference.
 - 2) Pull out the tubing while holding down the release button so that it does not pop out. If the release button is not pressed down sufficiently, there will be increased bite on the tubing and it will become more difficult to pull it out.
 - 3) When the removed tubing is to be used again, first cut off the section of the tubing which has been chewed.
Using the chewed portion of the tube as it is can cause problems such as leakage or difficulty in removing the tubing.

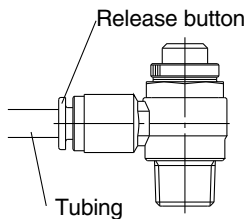

Operating Environment

⚠ Warning

1. Do not use in environments or locations where there is a danger of the speed controller being adversely affected.
Refer to page 3 regarding speed controller materials.
2. Provide shade in locations which receive direct sunlight.
3. Do not operate in locations where vibration or impact occurs.
4. Provide shielding in locations near heat sources.
When there are heat sources in the surrounding area, the product's temperature may rise due to radiated heat and exceed its operating temperature range. Block off the heat with a cover, etc.
5. Do not use in locations where static electric charges will be a problem. Consult SMC regarding use in this kind of environment.
6. Do not use in locations where spatter occurs.
There is a danger of spatter causing a fire. Consult SMC regarding use in this kind of environment.

Maintenance

⚠ Warning

1. Maintenance work

Compressed air can be dangerous if handled improperly. Element replacement and other maintenance, etc., should be performed by personnel having sufficient knowledge and experience pertaining to pneumatic equipment, while also adhering to the product specifications.

2. Pre-maintenance checks

When the product is to be removed, be sure to shut off the supply pressure, release compressed air in the pipelines and confirm an atmospheric release condition before proceeding.

3. Post-maintenance checks

After mounting, repair or renovation, supply compressed air and perform suitable function and leak tests. If an audible leak is detected or equipment does not operate properly, stop operation and confirm that mounting is correct.

4. Disassembly and modification is prohibited.

Do not disassemble or modify the main unit.

Precautions on Use of Other Tubing Brands

⚠ Caution

1. When using tubing brands other than SMC, confirm that the tubing outside diameter tolerances satisfy the following specifications.

- | | |
|------------------------|--------------|
| 1) Polyurethane tubing | Max. +0.15mm |
| | Max. -0.2mm |
| 2) Nylon tubing | Max. ±0.1mm |
| 3) Soft nylon tubing | Max. ±0.1mm |

Do not use tubing if the outside diameter tolerance is not satisfied. It may not be possible to connect the tubing, or air leakage or disconnection may occur after connection.

