

Modular Type Water Separator

New
RoHS

The no filter element design achieves a large flow and maintenance free construction.

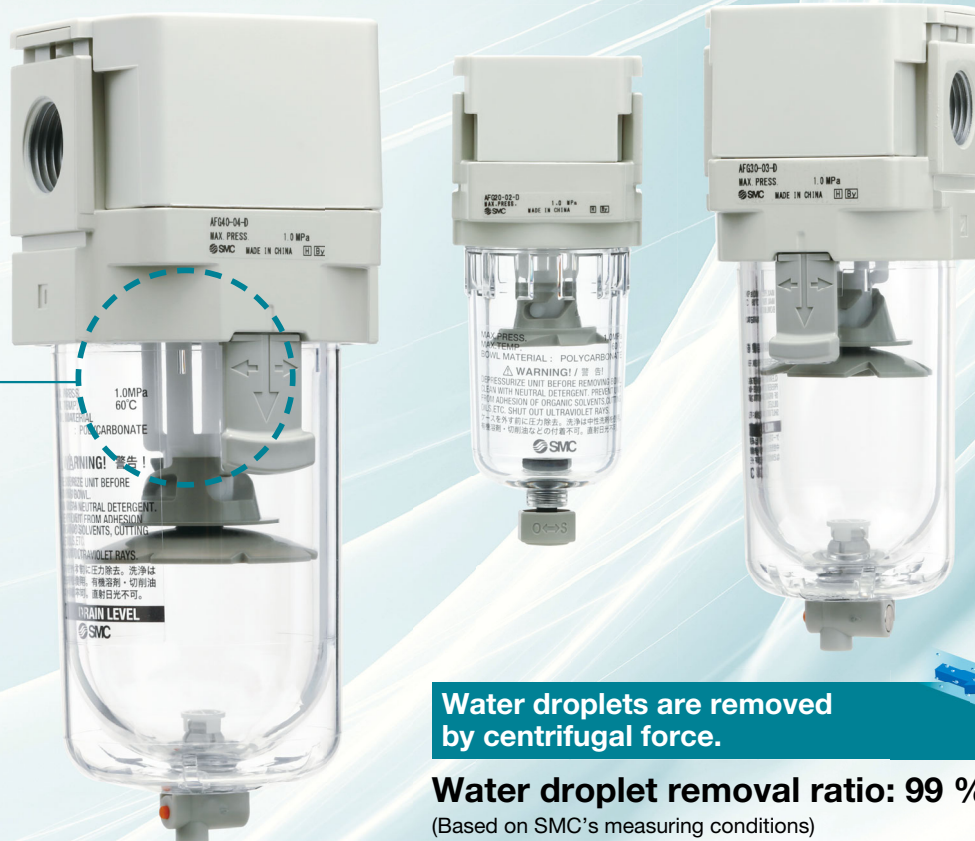

Water droplets are removed by centrifugal force.

Water droplet removal ratio: 99 %
(Based on SMC's measuring conditions)

Air containing water droplets is rotated to remove them by centrifugal force.



Modular Design with Uniform Body Style

Variations

Body size	Port size					Flow capacity [l/min(ANR)]				Page
	1/8	1/4	3/8	1/2	3/4	1000	2000	3000	4000	
20	●	●				1000				2
30		●	●			1500				
40		●	●	●	●				4000	

AFG-D Series



CAT.EUS30-25A-UK



Better environmental resistance with 2-layer construction



Transparent bowl guard
Material: Polycarbonate

The bowl is covered with a transparent bowl guard

* Body size 30 or more
Instead of windows on the bowl guard, the inner bowl is covered with a polycarbonate transparent bowl guard. Now, even if the environment changes and the bowl is exposed to corrosive chemical or oil splash, the foreign matter will not stick directly to the pressurized bowl. This reduces the risk of bowl breakage.

Superior visibility

The status inside the bowl can be checked from all directions.

Modular connection is possible.

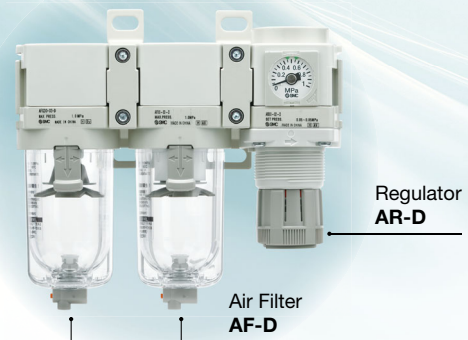

Water Separator
AFG-D

Air Filter
AF-D

Regulator
AR-D

Simple Specials System

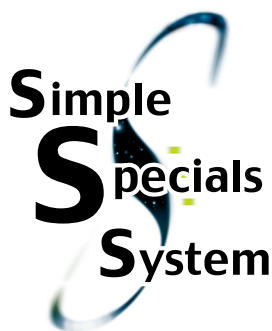

A system designed to respond quickly and easily to your special ordering needs

For modular connection units (shipped assembled), the simple specials system can be used.

Short lead times

This system enables us to respond to your special needs (additional machining, accessory assembly, or the designing of a modular unit) and deliver your personalized products as quickly as standard products.

Repeat orders

Once we receive a simple special part number from one of your previous orders, we will process the order, manufacture the product, and deliver it to you as quickly as possible.

Please contact your local sales representative for more details.

Water Separator

AFG20-D to AFG40-D

Symbol

Water Separator

Water Separator with Auto Drain

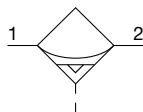
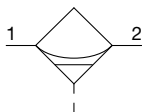

AFG30-D

How to Order

AFG **30** - **03** **BD** - **03** - **D**

① ② ③ ④ ⑤

· Option/Semi-standard: Select one each for a to f.
 · Option/Semi-standard symbol: When more than one specification is required, indicate in alphanumeric order.
 Example) AFG30-N03BD-2RZ-D

		Symbol	Description	①			
				Body size			
				20	30	40	
②	Pipe thread type	—	Rc	●	●	●	
		N	NPT	●	●	●	
		F	G	●	●	●	
+							
③	Port size	01	1/8	●	—	—	
		02	1/4	●	●	●	
		03	3/8	—	●	●	
		04	1/2	—	—	●	
		06	3/4	—	—	●	
+							
④	a	Mounting	—	Without mounting option	●	●	●
			B*1	With bracket	●	●	●
	+						
	b	Float type auto drain*2	—	Without auto drain	●	●	●
C*3			N.C. (Normally closed) Drain port is closed when pressure is not applied.	●	●	●	
D*4			N.O. (Normally open) Drain port is open when pressure is not applied.	—	●	●	
+							
⑤	c	Bowl*5	—	Polycarbonate bowl	●	●	●
			2	Metal bowl	●	●	●
			6	Nylon bowl	●	●	●
			8	Metal bowl with level gauge	—	●	●
			C	With bowl guard	●	—*6	—*6
			6C	With bowl guard (Nylon bowl)	●	—*7	—*7
	+						
	d	Drain port*8	—	With drain cock	●	●	●
			J*9	Drain guide 1/8	●	—	—
			W*10	Drain cock with barb fitting	—	●	●
	+						
	e	Flow direction	—	Flow direction: Left to right	●	●	●
R			Flow direction: Right to left	●	●	●	
+							
f	Pressure unit	—	Unit on product label: MPa, °C	●	●	●	
		Z*11	Unit on product label: psi, °F	○*12	○*12	○*12	

*1 Option B is included in the package with the product but does not come assembled. The assembly consists of 2 types of the bracket and 2 mounting screws.

*2 The auto drain port is Ø 10 One-touch fitting (② Pipe thread type: Rc, G) or Ø 3/8" One-touch fitting (② Pipe thread type: NPT)

*3 When pressure is not applied, condensate which does not start the auto drain mechanism will be left in the bowl. Releasing the residual condensate before ending operations for the day is recommended.

*4 If the compressor is small (0.75 kW, discharge flow is less than 100 l/min (ANR)), air leakage from the drain cock may occur during the start of operations. N.C. type is recommended.

*5 Refer to chemical data on page 5 for chemical resistance of the bowl.

*6 A bowl guard is provided as standard equipment (polycarbonate).

*7 A bowl guard is provided as standard equipment (nylon).

*8 The combination of float type auto drain C and D is not available.

*9 Without a valve function. The mounting screws are the same as the thread of ②.

*10 The combination of metal bowl 2 and 8 is not available.

*11 For the pipe thread type: NPT.

*12 ○: For the pipe thread type: NPT only

AFG20-D to AFG40-D Series

Standard Specifications

Model	AFG20-D	AFG30-D	AFG40-D	AFG40-06-D
Port size	1/8, 1/4	1/4, 3/8	1/4, 3/8, 1/2	3/4
Fluid	Air			
Ambient and fluid temperatures	-5 to 60 °C (No freezing)			
Proof pressure	1.5 MPa			
Max. operating pressure	1.0 MPa			
Auto drain minimum operating pressure	N.C.	0.1 MPa	0.15 MPa	
	N.O.	—	0.1 MPa	
Water droplet removal ratio*1	99 %			
Max. air flow capacity*2	1,000 l/min (ANR)	1,500 l/min (ANR)	4,000 l/min (ANR)	
Drain capacity	8 cm ³	25 cm ³	45 cm ³	
Bowl material	Polycarbonate			
Bowl guard	Semi-standard (Steel)	Standard (Polycarbonate)		
Weight	0.09 kg	0.17 kg	0.35 kg	0.39 kg

*1 Based on SMC's measurement conditions. A water droplet means condensed (liquified) content of water, and does not include water vapor which is not a form of condensation.

*2 The inlet pressure is at 0.7 MPa, and the flow rate is recorded at 20 °C, under atmospheric pressure, with a relative humidity of 65 %. The maximum air flow varies according to the inlet pressure.

Flow Rate Characteristics (Representative values)

AFG20-D

Rc1/4

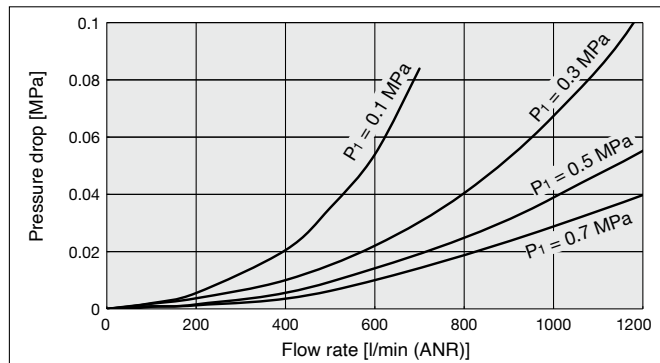

AFG30-D

Rc3/8

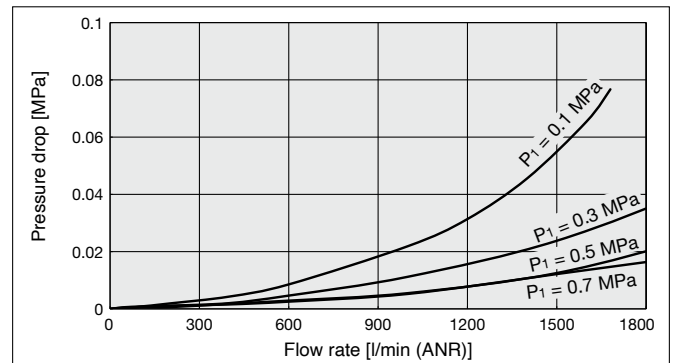

AFG40-D

Rc1/2

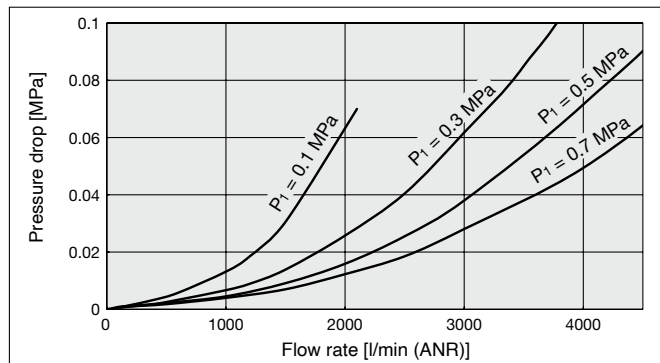

AFG40-06-D

Rc3/4

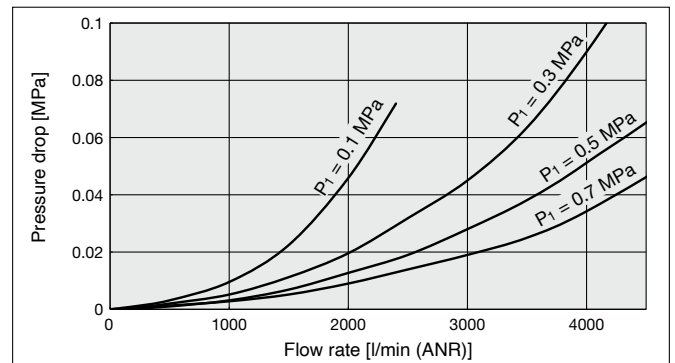

Bracket Assembly (Optional Parts)

AF 24 P-070AS

Body size

24	Size 20
34	Size 30
44	Size 40
49	Size 40-06

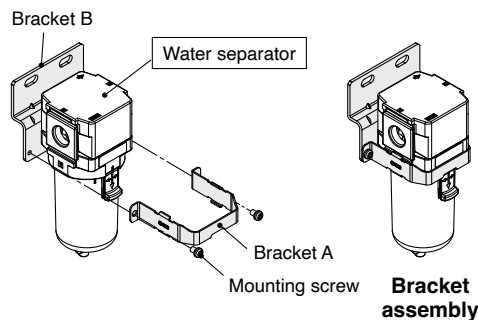

* The assembly consists of a bracket A/B and 2 mounting screws.

For the bowl assembly and the auto-drain part numbers, refer to the operation manual.

Water Separator **AFG20-D to AFG40-D Series**

Dimensions

AFG20-D

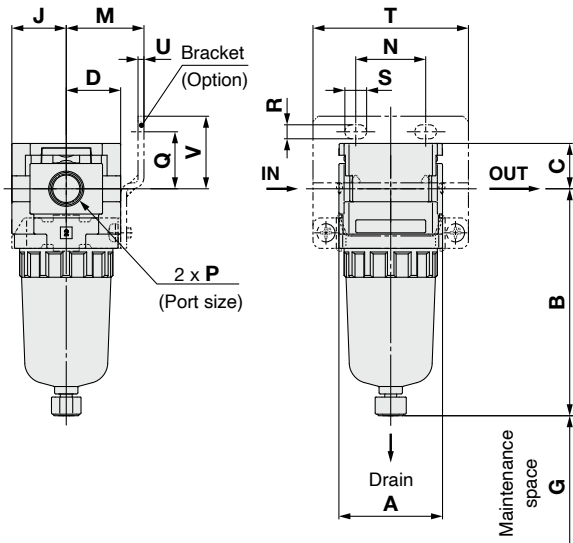

AFG30-D to AFG40-06-D

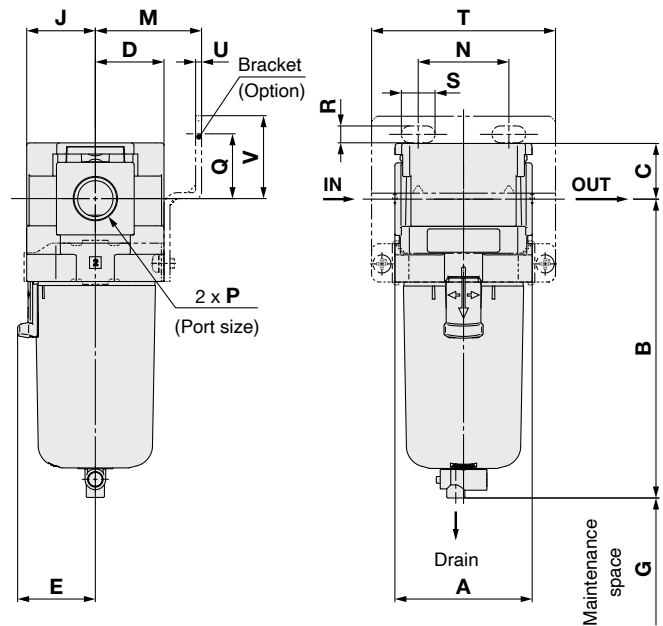

Applicable model	Optional specifications	Semi-standard					
	With auto drain	PC/PA bowl		Metal bowl		Metal bowl with level gauge	
		Drain cock with barb fitting	With drain guide	With drain cock	With drain guide	With drain cock	With drain guide
AFG20-D	 M5 x 0.8		 1/8 Width across flats 14	 1/8 Width across flats 14	 1/8 Width across flats 14		
AFG30-D to AFG40-06-D	N.O.: Black N.C.: Grey Thread type/Rc, G: Ø 10 One-touch fitting Thread type/NPT: Ø 3/8" One-touch fitting	 Barb fitting 1/4 applicable tubing: T0604	 1/4 Width across flats 17	 1/4 Width across flats 17	 1/4 Width across flats 17	 1/4 Width across flats 17	 1/4 Width across flats 17

Model	Standard specifications																	Optional specifications		
																		Bracket mount		With auto drain
	P	A	B	C	D	E	G	J	M	N	Q	R	S	T	U	V	B			
AFG20-D	1/8, 1/4	40	87.6	17.5	21	—	25	21	30	27	22	5.4	8.4	60	2.3	28	104.9			
AFG30-D	1/4, 3/8	53	115.4	21.5	26.5	30	35	26.5	41	35	25	6.5	13	71	2.3	32	157.1			
AFG40-D	1/4, 3/8, 1/2	70	147.1	25.5	35.5	38.4	40	35.5	50	52	30	8.5	12.5	88	2.3	39	186.9			
AFG40-06-D	3/4	75	149.1	27	35.5	38.4	40	35.5	50	52	34	8.5	12.5	88	2.3	43	188.9			

Model	Semi-standard specifications					
	PC/PA bowl		Metal bowl		Metal bowl with level gauge	
	With barb fitting	With drain guide	With drain cock	With drain guide	With drain cock	With drain guide
AFG20-D	B	B	B	B	B	B
AFG20-D	—	91.4	87.4	93.9	—	—
AFG30-D	123.9	122.2	117.8	122.3	137.8	142.3
AFG40-D	155.6	153.9	149.5	154	169.5	174
AFG40-06-D	157.6	155.9	151.5	156	171.5	176



AFG-D Series Specific Product Precautions

Be sure to read this before handling the products. Refer to the back cover for safety instructions. For F.R.L. units precautions, refer to the “Handling Precautions for SMC Products” and the “Operation Manual” on the SMC website: <https://www.smc.eu>

Design / Selection

Warning

1. The bowl material of the standard water separator is polycarbonate. Do not use in an environment where they are exposed to or come in contact with organic solvents, chemicals, cutting oil, synthetic oil, alkali, and thread lock solutions.

Chemical resistance of polycarbonate or nylon bowl

Type	Chemical name	Application examples	Material	
			Polycarbonate	Nylon
Acid	Hydrochloric acid Sulfuric acid Phosphoric acid Chromic acid	Acid washing liquid for metals	△	×
Alkaline	Sodium hydroxide (Caustic soda) Potash Calcium hydroxide (Slack lime) Ammonia water Sodium carbonate	Degreasing of metals Industrial salts Water-soluble cutting oil	×	○
Inorganic salts	Sodium sulfide Potassium nitrate Sodium sulfate	—	×	△
Chlorine solvents	Carbon tetrachloride Chloroform Ethylene chloride Methylene chloride	Cleansing liquid for metals Printing ink Dilution	×	△
Aromatic series	Benzene Toluene Paint thinner	Coatings Dry cleaning	×	△
Ketone	Acetone Methyl ethyl ketone Cyclohexane	Photographic film Dry cleaning Textile industries	×	×
Alcohol	Ethyl alcohol IPA Methyl alcohol	Antifreeze Adhesives	△	×
Oil	Gasoline Kerosene	—	×	○
Ester	Phthalic acid dimethyl Phthalic acid diethyl Acetic acid	Synthetic oil Anti-rust additives	×	○
Ether	Methyl ether Ethyl ether	Brake oil additives	×	○
Amino	Methyl amino	Cutting oil Brake oil additives Rubber accelerator	×	×
Others	Thread-lock fluid Seawater Leak tester	—	×	△

○: Essentially safe △: Some effects may occur. ×: Effects will occur.

* When the above factors are present, or there is some doubt, use a metal bowl for safety.

2. This product is designed to separate water droplet (condensed water). The moisture (water vapor), oil content, and solids contained in air, cannot be removed.

Safety Instructions

These safety instructions are intended to prevent hazardous situations and/or equipment damage. These instructions indicate the level of potential hazard with the labels of “Caution,” “Warning” or “Danger.” They are all important notes for safety and must be followed in addition to International Standards (ISO/IEC)¹⁾, and other safety regulations.

Danger:

Danger indicates a hazard with a high level of risk which, if not avoided, will result in death or serious injury.

Warning:

Warning indicates a hazard with a medium level of risk which, if not avoided, could result in death or serious injury.

Caution:

Caution indicates a hazard with a low level of risk which, if not avoided, could result in minor or moderate injury.

- 1) ISO 4414: Pneumatic fluid power – General rules and safety requirements for systems and their components.
- ISO 4413: Hydraulic fluid power – General rules and safety requirements for systems and their components.
- IEC 60204-1: Safety of machinery – Electrical equipment of machines. (Part 1: General requirements)
- ISO 10218-1: Robots and robotic devices - Safety requirements for industrial robots - Part 1: Robots.
- etc.

Warning

1. The compatibility of the product is the responsibility of the person who designs the equipment or decides its specifications.

Since the product specified here is used under various operating conditions, its compatibility with specific equipment must be decided by the person who designs the equipment or decides its specifications based on necessary analysis and test results. The expected performance and safety assurance of the equipment will be the responsibility of the person who has determined its compatibility with the product. This person should also continuously review all specifications of the product referring to its latest catalogue information, with a view to giving due consideration to any possibility of equipment failure when configuring the equipment.

2. Only personnel with appropriate training should operate machinery and equipment.

The product specified here may become unsafe if handled incorrectly. The assembly, operation and maintenance of machines or equipment including our products must be performed by an operator who is appropriately trained and experienced.

3. Do not service or attempt to remove product and machinery/equipment until safety is confirmed.

1. The inspection and maintenance of machinery/equipment should only be performed after measures to prevent falling or runaway of the driven objects have been confirmed.
2. When the product is to be removed, confirm that the safety measures as mentioned above are implemented and the power from any appropriate source is cut, and read and understand the specific product precautions of all relevant products carefully.
3. Before machinery/equipment is restarted, take measures to prevent unexpected operation and malfunction.

4. Our products cannot be used beyond their specifications. Our products are not developed, designed, and manufactured to be used under the following conditions or environments. Use under such conditions or environments is not covered.

1. Conditions and environments outside of the given specifications, or use outdoors or in a place exposed to direct sunlight.
2. Use for nuclear power, railways, aviation, space equipment, ships, vehicles, military application, equipment affecting human life, body, and property, fuel equipment, entertainment equipment, emergency shut-off circuits, press clutches, brake circuits, safety equipment, etc., and use for applications that do not conform to standard specifications such as catalogues and operation manuals.
3. Use for interlock circuits, except for use with double interlock such as installing a mechanical protection function in case of failure. Please periodically inspect the product to confirm that the product is operating properly.

Caution

We develop, design, and manufacture our products to be used for automatic control equipment, and provide them for peaceful use in manufacturing industries.

Use in non-manufacturing industries is not covered.

Products we manufacture and sell cannot be used for the purpose of transactions or certification specified in the Measurement Act.

The new Measurement Act prohibits use of any unit other than SI units in Japan.

Limited warranty and Disclaimer/Compliance Requirements

The product used is subject to the following “Limited warranty and Disclaimer” and “Compliance Requirements”. Read and accept them before using the product.

Limited warranty and Disclaimer

1. The warranty period of the product is 1 year in service or 1.5 years after the product is delivered, whichever is first.²⁾ Also, the product may have specified durability, running distance or replacement parts. Please consult your nearest sales branch.
2. For any failure or damage reported within the warranty period which is clearly our responsibility, a replacement product or necessary parts will be provided. This limited warranty applies only to our product independently, and not to any other damage incurred due to the failure of the product.
3. Prior to using SMC products, please read and understand the warranty terms and disclaimers noted in the specified catalogue for the particular products.
- 2) Vacuum pads are excluded from this 1 year warranty.
A vacuum pad is a consumable part, so it is warranted for a year after it is delivered. Also, even within the warranty period, the wear of a product due to the use of the vacuum pad or failure due to the deterioration of rubber material are not covered by the limited warranty.

Compliance Requirements

1. The use of SMC products with production equipment for the manufacture of weapons of mass destruction (WMD) or any other weapon is strictly prohibited.
2. The exports of SMC products or technology from one country to another are governed by the relevant security laws and regulations of the countries involved in the transaction. Prior to the shipment of a SMC product to another country, assure that all local rules governing that export are known and followed.

Safety Instructions

Be sure to read “Handling Precautions for SMC Products” (M-E03-3) before using.

SMC Corporation (Europe)

Austria	+43 (0)2262622800	www.smc.at	office@smc.at
Belgium	+32 (0)33551464	www.smc.be	info@smc.be
Bulgaria	+359 (0)2807670	www.smc.bg	office@smc.bg
Croatia	+385 (0)13707288	www.smc.hr	office@smc.hr
Czech Republic	+420 541424611	www.smc.cz	office@smc.cz
Denmark	+45 70252900	www.smc.dk.com	smc@smcdk.com
Estonia	+372 651 0370	www.smcee.ee	info@smcee.ee
Finland	+358 207513513	www.smc.fi	smc.fi@smc.fi
France	+33 (0)164761000	www.smc-france.fr	supportclient@smc-france.fr
Germany	+49 (0)61034020	www.smc.de	info@smc.de
Greece	+30 210 2717265	www.smchellas.gr	sales@smchellas.gr
Hungary	+36 23513000	www.smc.hu	office@smc.hu
Ireland	+353 (0)14039000	www.smcautomation.ie	sales@smcautomation.ie
Italy	+39 03990691	www.smcitalia.it	mailbox@smcitalia.it
Latvia	+371 67817700	www.smc.lv	info@smc.lv

Lithuania	+370 5 2308118	www.smclt.lt	info@smclt.lt
Netherlands	+31 (0)205318888	www.smc.nl	info@smc.nl
Norway	+47 67129020	www.smc-norge.no	post@smc-norge.no
Poland	+48 222119600	www.smc.pl	sales@smc.pl
Portugal	+351 214724500	www.smc.eu	apoioclientept@smc.smces.es
Romania	+40 213205111	www.smcromania.ro	smcromania@smcromania.ro
Russia	+7 (812)3036600	www.smc.eu	sales@smcru.com
Slovakia	+421 (0)413213212	www.smc.sk	office@smc.sk
Slovenia	+386 (0)73885412	www.smc.si	office@smc.si
Spain	+34 945184100	www.smc.eu	post@smc.smces.es
Sweden	+46 (0)86031240	www.smc.nu	smc@smc.nu
Switzerland	+41 (0)523963131	www.smc.ch	info@smc.ch
Turkey	+90 212 489 0 440	www.smcturkey.com.tr	info@smcturkey.com.tr
UK	+44 (0)845 121 5122	www.smc.uk	sales@smc.uk

South Africa +27 10 900 1233 www.smzca.co.za zasales@smzca.co.za