

Auto Drain Valve

New

RoHS

Longer life & Higher resistance to foreign matter

Improved foreign matter resistance

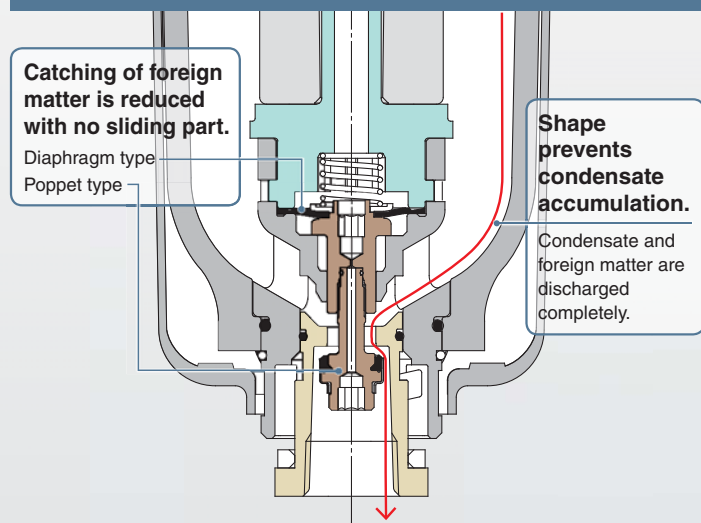

Increase in condensate discharge

Reduction of operation frequency due to increased condensate discharge

- Drain discharge: Max. **100 cm³/cycle**
(3 times compared with the current model)

Double layer design

- Better visibility & environmental resistance
- The bowl is covered with a transparent bowl guard.



With manual discharge mechanism

N.O.: Black
N.C.: Grey

AD402-A Series



CAT.EUS40-65A-UK

Transparent bowl guard

■ Better environmental resistance: Transparent bowl guard can protect the inner bowl!

Windows on the bowl guard have been removed and the inner bowl is instead covered with a polycarbonate transparent bowl guard. Now, even if the environment changes and the bowl is exposed to corrosive chemical or oil splash, the foreign matter will not stick directly to the pressurised bowl. This can reduce risk of bowl breakage.

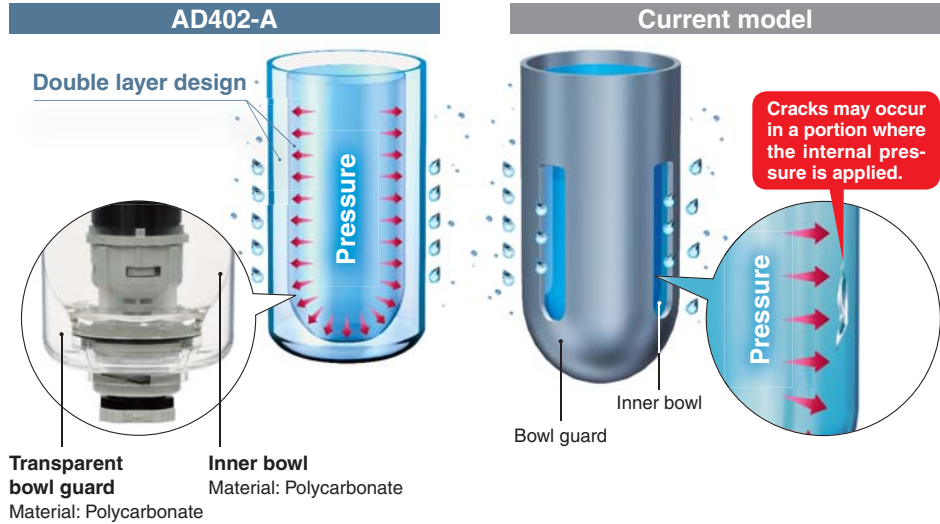

■ Better visibility: 360°

Use of transparent bowl guard makes it possible to check the condensate inside the bowl from the entire periphery.

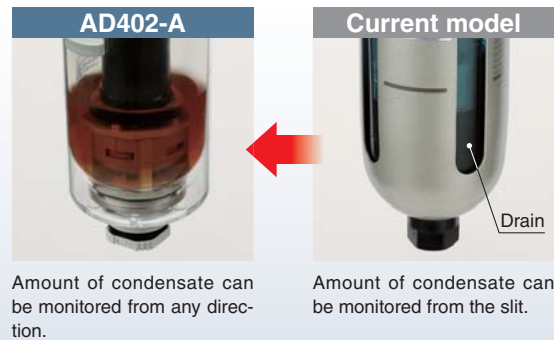

Options

■ Bowl material can be selected according to the operating environments.



■ Bleed valve equipped type can be selected.



Auto Drain Valve

AD402-A Series



Symbol

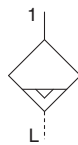

Specifications

Standard Specifications

Model	AD402-A
Auto drain type	Float type
Auto drain valve type	N.C. (Normally closed: Drain port is closed when pressure is not applied) N.O. (Normally open: Drain port is open when pressure is not applied)
Fluid	Compressed air
Ambient and fluid temperatures	-5 to 60°C (No freezing)
Proof pressure	1.5 MPa
Max. operating pressure	1.0 MPa
Operating pressure range*1	N.C.: 0.15 to 1.0 MPa N.O.: 0.1 to 1.0 MPa
Port size	1/4, 3/8, 1/2
Drain port size	3/8
Bowl material	Polycarbonate
Bowl guard material	Polycarbonate
Weight	0.46 kg
Appearance color	White

*1 Discharged flow rate of the air compressor should be 400 l/min (ANR) or more.

How to Order

AD402- 04D - -A

Thread type

Symbol	Type
Nil	Rc
F	G
N	NPT

Port size

Symbol	Port size
02	1/4
03	3/8
04	1/2

Auto drain type

Symbol	Description
C*1	N.C. (Normally closed) Drain port is closed when pressure is not applied.
D*2	N.O. (Normally open) Drain port is open when pressure is not applied.

*1 When pressure is not applied, condensate which does not start the auto drain mechanism will be left in the bowl. Releasing the residual condensate before ending operations for the day is recommended.

*2 If the compressor is smaller than 3.7 kW, or discharge flow is less than 400 l/min (ANR), air leakage from the drain cock may occur during start of operations. N.C. type is recommended.

Proper use of float type auto drain ▶ See **P.6**

Semi-standard symbol: When plural options are required, indicate them in alphanumeric order.
Example) AD402-N04D-2VZ-A

Semi-standard specifications

	Symbol	Description
Bowl	—	Polycarbonate bowl
	2	Metal bowl
	6	Nylon bowl
Valve	—	None*4
	V	With bleed valve
Pressure unit	—	Name plate and caution plate for bowl in SI units
	Z*5	Name plate and caution plate for bowl in imperial units

*3 Chemical resistance of the bowl ▶ See **P.7**

*4 For port size 1/4, the valve already mounted.

*5 Only NPT can be selected.

Construction/Dimensions

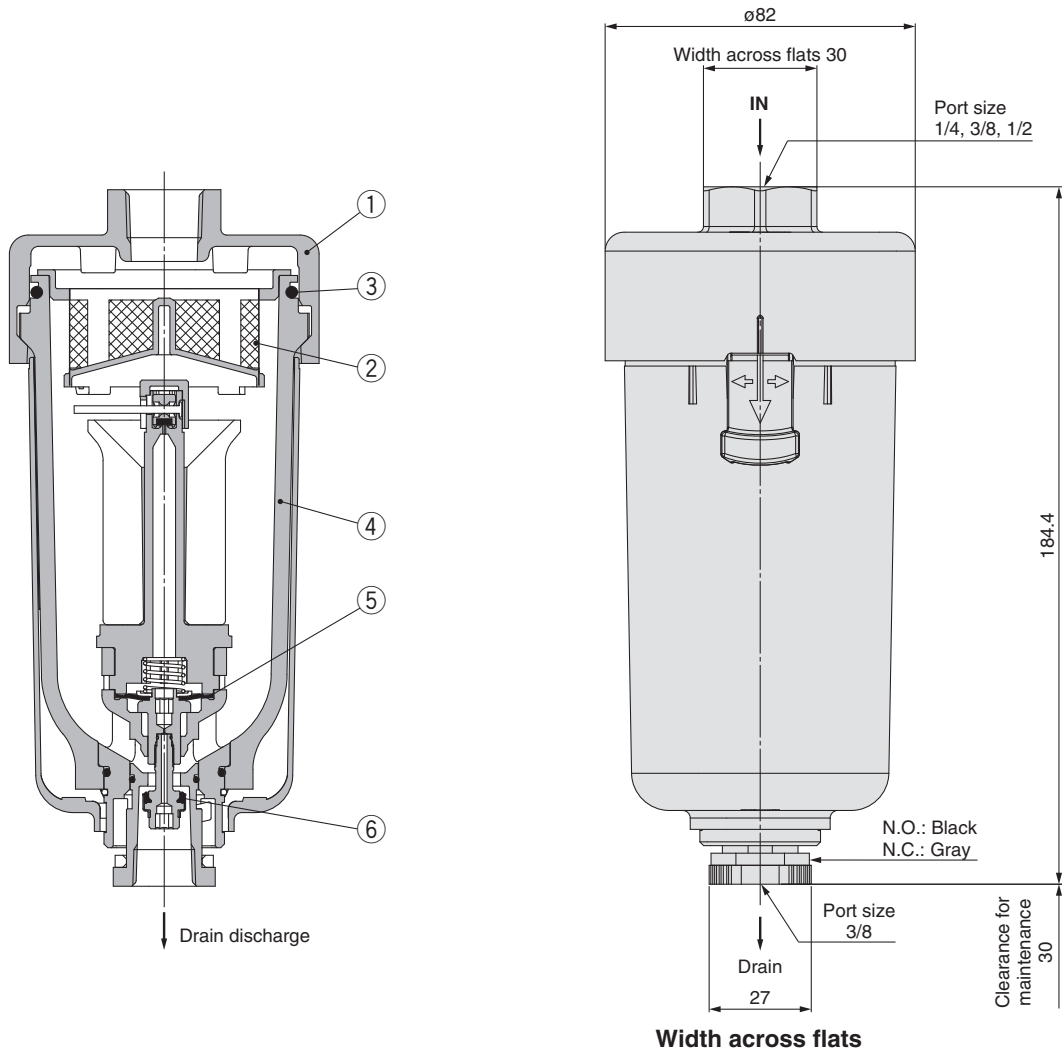

Component Parts

No.	Description	Material	Colour
1	Body	Aluminium die-cast	White
5	Diaphragm	FKM	—
6	Main valve	FKM	—

Replacement Parts

No.	Description	Material	Part no.
2	Element	Nylon	AD402P-040S
3	Bowl O-ring	NBR	KA00463
4	Bowl assembly*1	See below.	See below.

Bowl Assembly Part Nos.

Bowl material	Bowl assembly part nos.	
	Normally open	Normally closed
Polycarbonate	AD52□-A	AD51□-A
Nylon	AD52□-6-A	AD51□-6-A
Metal	AD52□-2-A	AD51□-2-A

*1 Enter the piping thread type to □ of the bowl assembly part number.
 —: Rc thread, N: NPT thread, F: G thread
 Please consult with SMC separately for psi and °F unit display specifications.
 Including the bowl O-ring.

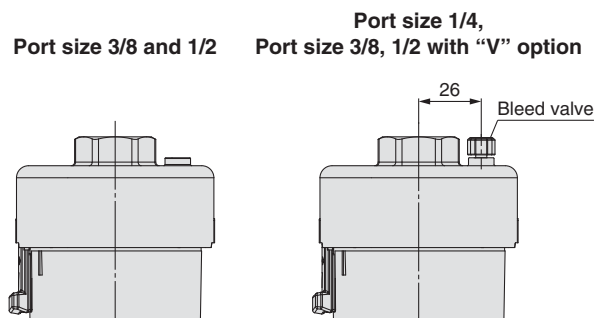

AD402-A Series

Working Principle: Float Type Auto Drain

N.O. (Normally open)

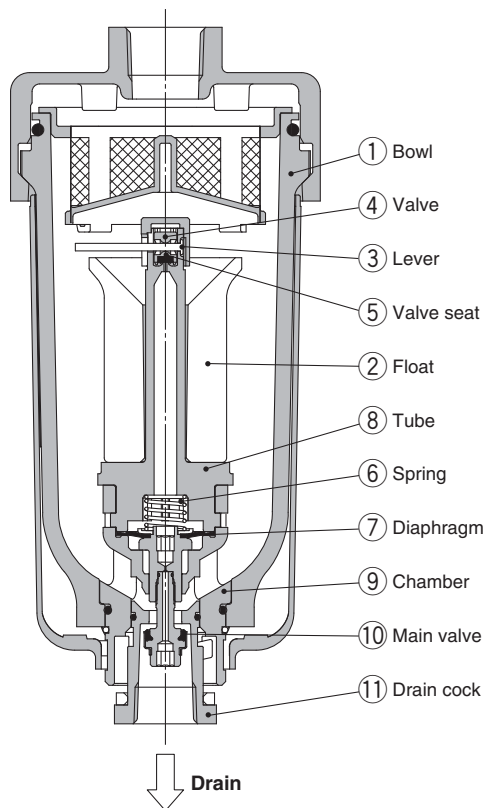

N.C. (Normally closed)

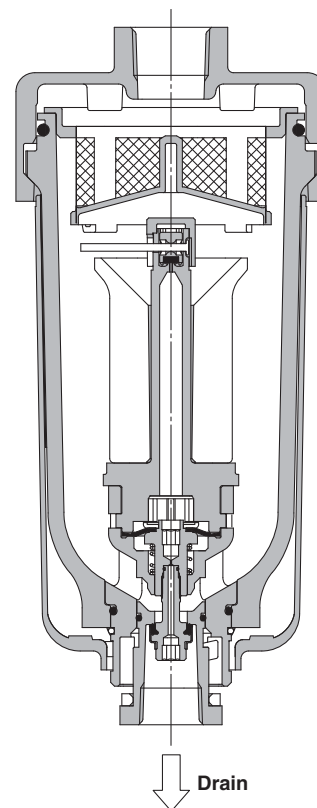

● **When pressure inside the bowl is released:**

When pressure is released from the bowl ①, the diaphragm ⑦ is lowered by the spring ⑥. The seal at the main valve ⑩ is interrupted, and the outside air flows inside the bowl ① through the chamber ⑨ and the drain cock ⑪. Therefore, if there is an accumulation of condensate in the bowl ①, it will drain out through the drain cock.

● **When pressure is applied inside the bowl:**

When pressure inside the bowl is 0.1 MPa or higher, the force of the diaphragm ⑦ surpasses the force of the spring ⑥, and the diaphragm goes up. This pushes the main valve ⑩ up so that it creates a seal, and the inside of the bowl ① is shut off from the outside air. If there is no accumulation of condensate in the bowl ① at this time, the float ② will be pulled down by its own weight, causing the valve ④, which is connected to the lever ③, to seal the valve seat ⑤.

● **When there is an accumulation of condensate in the bowl:**

The float ② rises due to its own buoyancy and the seal at the valve seat ⑤ is interrupted. This allows the pressure inside the bowl ① to enter the tube ⑧. The result is that the combined pressure inside the tube ⑧ and the force of the spring ⑥ lowers the diaphragm ⑦. This causes the seal at the main valve ⑩ to be interrupted, and the accumulated condensate in the bowl ① drains out through the drain cock ⑪.

Turning the drain cock ⑪ manually counterclockwise rises the drain cock ⑪, which pushes open the seal created by the main valve ⑩, thus allowing the condensate to drain out.

● **When pressure inside the bowl is released:**

Even when pressure inside the bowl ① is released, the spring ⑥ keeps the diaphragm ⑦ in its upward position. This keeps the seal created by the main valve ⑩ in place; thus, the inside of the bowl ① is shut off from the outside air. Therefore, even if there is an accumulation of condensate in the bowl ①, it will not drain out.

● **When pressure is applied inside the bowl:**

Even when pressure is applied inside the bowl ①, the combined force of the spring ⑥ and the pressure inside the bowl ① keeps the diaphragm ⑦ in its upward position. This maintains the seal created by the main valve ⑩ in place; thus, the inside of the bowl ① is shut off from the outside air. If there is no accumulation of condensate in the bowl ① at this time, the float ② will be pulled down by its own weight, causing the valve ④, which is connected to the lever ③, to seal the valve seat ⑤.

● **When there is an accumulation of condensate in the bowl:**

The float ② rises due to its own buoyancy and the seal at the valve seat ⑤ is interrupted. This allows the pressure inside the bowl ① to enter the tube ⑧. The result is that the pressure inside the tube ⑧ surpasses the force of the spring ⑥ and pushes the diaphragm ⑦ downward. This causes the seal at the main valve ⑩ to be interrupted and the accumulated condensate in the bowl ① drains out through the drain cock ⑪.

Turning the drain cock ⑪ manually counterclockwise rises the drain cock ⑪, which pushes open the seal created by the main valve ⑩, thus allowing the condensate to drain out.

Operating State and Proper Use of Float Type Auto Drain

Auto drain	When pressure is not applied (After exhausting residual pressure)	When pressure is applied		Minimum operating pressure
		Before drain accumulates	When drain accumulates	
N.O. (Normally open)	<p>Drain discharged (Open)</p>	<p>Drain not discharged (Close)</p>	<p>Drain discharged (Open)</p>	0.1 MPa or more
N.C. (Normally closed)	<p>Drain not discharged (Close)</p>			0.15 MPa or more

* For both N.O. and N.C., the drain can be discharged manually by turning the drain cock to the "O" position.

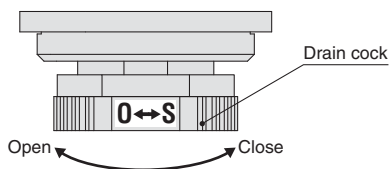

Proper use			Recommended auto drain
Compressor	When pressure is not applied (After exhausting residual pressure)	Cold climates	
<p>3.7 kW or more</p>	<p>Drain not accumulated Do not want to accumulate drain generated at the inlet side when pressure is not applied.</p>	<p>Want to prevent troubles caused by freezing.</p>	N.O.*1 (Normally open)
<p>Less than 3.7 kW</p>	<p>Drain accumulated</p>	—	N.C. (Normally closed)

*1 For N.O. type, the drain discharge passage is open when pressure is not applied. For this reason, the drain exhaust port is not closed completely in a compressor with a small supply amount (less than 3.7 kW) and the air will ceaselessly blow out.



AD402-A Series Specific Product Precautions 1

Be sure to read this before handling the products. Refer to the back cover for safety instructions. For air preparation equipment precautions, refer to the “Handling Precautions for SMC Products” and the “Operation Manual” on the SMC website: <http://www.smc.eu>

Design

Warning

- The standard bowl for the auto drain valve is made of polycarbonate. Do not use in an environment where they are exposed to or come in contact with synthetic oil, organic solvents, chemicals, cutting oil, alkali, and thread lock solutions.

Effects of atmosphere of organic solvents and chemicals, and where these elements are likely to adhere to the equipment.
Chemical data for substances causing degradation (Reference)

Type	Chemical name	Application examples	Material	
			Polycarbonate	Nylon
Acid	Hydrochloric acid Sulfuric acid, Phosphoric acid Chromic acid	Acid washing liquid for metals	△	×
Alkaline	Sodium hydroxide (Caustic soda) Potash Calcium hydroxide (Slack lime) Ammonia water Carbonate of soda	Degreasing of metals Industrial salts Water-soluble cutting oil	×	○
Inorganic salts	Sodium sulfide Potassium nitrate Sulfate of soda	—	×	△
Chlorine solvents	Carbon tetrachloride Chloroform Ethylene chloride Methylene chloride	Cleansing liquid for metals Printing ink Dilution	×	△
Aromatic series	Benzene Toluene Paint thinner	Coatings Dry cleaning	×	△
Ketone	Acetone Methyl ethyl ketone Cyclohexane	Photographic film Dry cleaning Textile industries	×	×
Alcohol	Ethyl alcohol IPA Methyl alcohol	Anti-freeze Adhesives	△	×
Oil	Gasoline Kerosene	—	×	○
Ester	Dimethyl phthalate Diethyl phthalate Acetic acid	Synthetic oil Anti-rust additives	×	○
Ether	Methyl ether Ethyl ether	Brake oil additives	×	○
Amino	Methyl amino	Cutting oil Brake oil additives Rubber accelerant	×	×
Others	Thread-lock fluid Seawater Leak tester	—	×	△

○: Essentially safe △: Some effects may occur. ×: Effects will occur.

When the above factors are present, or there is some doubt, use a metal bowl for safety.

Warning

- Keep the compressed air and the ambient temperature of the location where this product is installed within the range of -5 to 60 °C. Exceeding this range could lead to a failure or malfunction.
- Avoid using this product in an area where corrosive gases, flammable gases or organic solvents are contained in the compressed air or in the surrounding air.

Selection

Caution

- Operate under the following conditions to avoid malfunction.

<N.O. type>

- Operating pressure: 0.1 MPa or more
- Operate the compressor at 3.7 kW (400 L/min (ANR)) or more. Air may ceaselessly blow out of the drain discharge area when a compressor with a small air discharge volume is used since the valve does not close unless the air pressure is 0.1 MPa or higher.

<N.C. type>

- Operating pressure: 0.15 MPa or more

- Operation failure will occur if a large amount of condensate rushes into the valve. Do not use the auto drain valve in such environment.

Piping

Warning

- Hold the female thread side and tighten to the recommended torque when screwing in the piping material.

Insufficient tightening torque may cause loosening or defective sealing. Excessive tightening torque may damage the thread, etc.

If it is tightened without holding the female thread side, excessive force will be directly applied to the internal parts, resulting in a product failure.

Recommended Torque

Unit: N·m

Connection thread	1/4	3/8	1/2
Torque	12 to 14	22 to 24	28 to 30

- Preparation before piping

Before piping is connected, it should be thoroughly blown out with air (flushing) or washed to remove chips, cutting oil, and other debris from inside the pipe.

- Winding of sealant tape

When screwing piping or fittings into ports, ensure that chips from the pipe threads or sealing material do not enter the piping. Also, if sealant tape is used, leave 1.5 to 2 thread ridges exposed at the end of the threads.

- For drain piping, use piping whose I.D. is \varnothing 10 mm or larger, and whose length is 5 m or less. Avoid riser piping.



AD402-A Series Specific Product Precautions 2

Be sure to read this before handling the products. Refer to the back cover for safety instructions. For air preparation equipment precautions, refer to the “Handling Precautions for SMC Products” and the “Operation Manual” on the SMC website: <http://www.smc.eu>

Mounting

⚠ Caution

1. About the mounting orientation of the products

Be sure to install the product with “out port” down in a vertical position. If it is installed diagonally, laterally, or upside down, the drain may splash to the outlet side.

2. Install with at least 30 mm of free space below the product to allow for maintenance.

3. To place this product near the air compressor, install in such a way that the vibrations will not be transmitted.

4. When installing the bowl, install it so that the lock button lines up to the groove of the front (or the back) of the body.

Failure to do so may cause the bowl to fall off or break.



Air Supply

⚠ Caution

1. The product is not applicable to gases other than compressed air.

The product is not applicable to gases other than compressed air (example: oxygen, hydrogen, flammable gas, mixed gas).

2. Do not use compressed air that contains chemicals, organic solvents, salt, or corrosive gases.

Do not use compressed gas containing chemicals, organic solvents, salt or corrosive gas. This can cause rust, damage to rubber and resin parts, or malfunction.

3. Operate within the specified operating pressure range.

Damage, failure, or malfunction may occur if the product is operated above the maximum operating pressure.

Operating Environment

⚠ Warning

1. Do not use in explosive atmospheres.

2. Do not use in locations subject to vibration or impact.

3. A protective cover should be used to shield the product from direct sunlight.

4. Remove any sources of excessive heat.

Maintenance

⚠ Warning

1. Perform maintenance inspection according to the procedures indicated in the operation manual. If handled improperly, the malfunction or damage of machinery and equipment may occur.

2. Perform periodical inspections to detect any cracks, scratches, or other deterioration of the resin bowl. Replace with a new bowl or metal bowl when any kind of deterioration is found. Otherwise, damage may occur. Investigate and/or review the operating conditions if necessary.

3. And if removing the dirt by washing the resin bowl, never use washing materials other than a neutral detergent. Failure to do so may cause damage to the bowl.

⚠ Caution

4. Manual operation

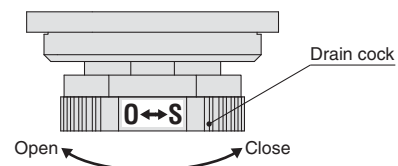

A manual knob attached to the auto drain end is tightened to the “S” side in normal operation. The drain can be discharged by loosening it to the “O” side. (Be careful, however, if pressure remains inside the bowl when the drain is discharged, the drain will blow out from the drain port.)



5. When discharging condensate manually, do not apply excessive torque to the drain cock by using a tool. Failure to do so may cause damage to the product.

Safety Instructions

These safety instructions are intended to prevent hazardous situations and/or equipment damage. These instructions indicate the level of potential hazard with the labels of “Caution,” “Warning” or “Danger.” They are all important notes for safety and must be followed in addition to International Standards (ISO/IEC)*1), and other safety regulations.

-  **Caution:** Caution indicates a hazard with a low level of risk which, if not avoided, could result in minor or moderate injury.
-  **Warning:** Warning indicates a hazard with a medium level of risk which, if not avoided, could result in death or serious injury.
-  **Danger:** Danger indicates a hazard with a high level of risk which, if not avoided, will result in death or serious injury.

- *1) ISO 4414: Pneumatic fluid power – General rules relating to systems.
- ISO 4413: Hydraulic fluid power – General rules relating to systems.
- IEC 60204-1: Safety of machinery – Electrical equipment of machines. (Part 1: General requirements)
- ISO 10218-1: Manipulating industrial robots - Safety. etc.

Warning

- The compatibility of the product is the responsibility of the person who designs the equipment or decides its specifications.**
Since the product specified here is used under various operating conditions, its compatibility with specific equipment must be decided by the person who designs the equipment or decides its specifications based on necessary analysis and test results. The expected performance and safety assurance of the equipment will be the responsibility of the person who has determined its compatibility with the product. This person should also continuously review all specifications of the product referring to its latest catalogue information, with a view to giving due consideration to any possibility of equipment failure when configuring the equipment.
- Only personnel with appropriate training should operate machinery and equipment.**
The product specified here may become unsafe if handled incorrectly. The assembly, operation and maintenance of machines or equipment including our products must be performed by an operator who is appropriately trained and experienced.
- Do not service or attempt to remove product and machinery/equipment until safety is confirmed.**
 - The inspection and maintenance of machinery/equipment should only be performed after measures to prevent falling or runaway of the driven objects have been confirmed.
 - When the product is to be removed, confirm that the safety measures as mentioned above are implemented and the power from any appropriate source is cut, and read and understand the specific product precautions of all relevant products carefully.
 - Before machinery/equipment is restarted, take measures to prevent unexpected operation and malfunction.
- Contact SMC beforehand and take special consideration of safety measures if the product is to be used in any of the following conditions.**
 - Conditions and environments outside of the given specifications, or use outdoors or in a place exposed to direct sunlight.
 - Installation on equipment in conjunction with atomic energy, railways, air navigation, space, shipping, vehicles, military, medical treatment, combustion and recreation, or equipment in contact with food and beverages, emergency stop circuits, clutch and brake circuits in press applications, safety equipment or other applications unsuitable for the standard specifications described in the product catalogue.
 - An application which could have negative effects on people, property, or animals requiring special safety analysis.
 - Use in an interlock circuit, which requires the provision of double interlock for possible failure by using a mechanical protective function, and periodical checks to confirm proper operation.

Limited warranty and Disclaimer/ Compliance Requirements

The product used is subject to the following “Limited warranty and Disclaimer” and “Compliance Requirements”. Read and accept them before using the product.

Limited warranty and Disclaimer

- The warranty period of the product is 1 year in service or 1.5 years after the product is delivered, whichever is first.*2) Also, the product may have specified durability, running distance or replacement parts. Please consult your nearest sales branch.
- For any failure or damage reported within the warranty period which is clearly our responsibility, a replacement product or necessary parts will be provided. This limited warranty applies only to our product independently, and not to any other damage incurred due to the failure of the product.
- Prior to using SMC products, please read and understand the warranty terms and disclaimers noted in the specified catalogue for the particular products.

*2) Vacuum pads are excluded from this 1 year warranty. A vacuum pad is a consumable part, so it is warranted for a year after it is delivered. Also, even within the warranty period, the wear of a product due to the use of the vacuum pad or failure due to the deterioration of rubber material are not covered by the limited warranty.

Compliance Requirements

- The use of SMC products with production equipment for the manufacture of weapons of mass destruction (WMD) or any other weapon is strictly prohibited.
- The exports of SMC products or technology from one country to another are governed by the relevant security laws and regulations of the countries involved in the transaction. Prior to the shipment of a SMC product to another country, assure that all local rules governing that export are known and followed.

Caution

- The product is provided for use in manufacturing industries.**
The product herein described is basically provided for peaceful use in manufacturing industries. If considering using the product in other industries, consult SMC beforehand and exchange specifications or a contract if necessary. If anything is unclear, contact your nearest sales branch.

Caution

SMC products are not intended for use as instruments for legal metrology.
Measurement instruments that SMC manufactures or sells have not been qualified by type approval tests relevant to the metrology (measurement) laws of each country. Therefore, SMC products cannot be used for business or certification ordained by the metrology (measurement) laws of each country.

Safety Instructions

Be sure to read “Handling Precautions for SMC Products” (M-E03-3) before using.

SMC Corporation (Europe)

Austria	+43 (0)2262622800	www.smc.at	office@smc.at	Lithuania	+370 5 2308118	www.smclt.lt	info@smclt.lt
Belgium	+32 (0)33551464	www.smcpnematics.be	info@smcpneumatics.be	Netherlands	+31 (0)205318888	www.smcpnematics.nl	info@smcpneumatics.nl
Bulgaria	+359 (0)2807670	www.smc.bg	office@smc.bg	Norway	+47 67129020	www.smc-norge.no	post@smc-norge.no
Croatia	+385 (0)13707288	www.smc.hr	office@smc.hr	Poland	+48 222119600	www.smc.pl	office@smc.pl
Czech Republic	+420 541424611	www.smc.cz	office@smc.cz	Portugal	+351 226166570	www.smc.eu	postpt@smc.smces.es
Denmark	+45 70252900	www.smcdk.com	smc@smcdk.com	Romania	+40 213205111	www.smcromania.ro	smcromania@smcromania.ro
Estonia	+372 6510370	www.smcpnematics.ee	smc@smcpneumatics.ee	Russia	+7 8127185445	www.smc-pneumatik.ru	info@smc-pneumatik.ru
Finland	+358 207513513	www.smc.fi	smc@smc.fi	Slovakia	+421 (0)413213212	www.smc.sk	office@smc.sk
France	+33 (0)164761000	www.smc-france.fr	info@smc-france.fr	Slovenia	+386 (0)73885412	www.smc.si	office@smc.si
Germany	+49 (0)61034020	www.smc.de	info@smc.de	Spain	+34 902184100	www.smc.eu	post@smc.smces.es
Greece	+30 210 2717265	www.smchellas.gr	sales@smchellas.gr	Sweden	+46 (0)86031200	www.smc.nu	post@smc.nu
Hungary	+36 23513000	www.smc.hu	office@smc.hu	Switzerland	+41 (0)523963131	www.smc.ch	info@smc.ch
Ireland	+353 (0)14039000	www.smcpnematics.ie	sales@smcpneumatics.ie	Turkey	+90 212 489 0 440	www.smcpnomatik.com.tr	info@smcpnomatik.com.tr
Italy	+39 0292711	www.smcitalia.it	mailbox@smcitalia.it	UK	+44 (0)845 121 5122	www.smcpnematics.co.uk	sales@smcpneumatics.co.uk
Latvia	+371 67817700	www.smc.lv	info@smclv.lv				

SMC CORPORATION Akihbara UDX 15F, 4-14-1, Sotokanda, Chiyoda-ku, Tokyo 101-0021, JAPAN Phone: 03-5207-8249 FAX: 03-5298-5362