



# Operation Manual

PRODUCT NAME

Flow Controller for Water

MODEL / Series / Product Number

*FC3W5##*

**SMC Corporation**

## Table of Contents

Safety Instructions	3
Model Indication and How to Order	11
Names and Functions of Product Parts	13
Definition and terminology	15
Mounting and Installation	16
Installation by bracket	16
Direct mounting	16
Piping method	17
Wiring method	19
Flow rate command input and controlled flow rate	21
Controlled flow rate and analogue output	22
Troubleshooting	23
Specifications	26
Outline dimensions	28
Lead wire with M12 connector	29



# Safety Instructions

These safety instructions are intended to prevent hazardous situations and/or equipment damage. These instructions indicate the level of potential hazard with the labels of “**Caution**,” “**Warning**” or “**Danger**.” They are all important notes for safety and must be followed in addition to International Standards (ISO/IEC)<sup>\*1)</sup>, and other safety regulations.

\*1) ISO 4414: Pneumatic fluid power - General rules and safety requirements for systems and their components  
ISO 4413: Hydraulic fluid power - General rules and safety requirements for systems and their components  
IEC 60204-1: Safety of machinery - Electrical equipment of machines - Part 1: General requirements  
ISO 10218-1: Robots and robotic devices - Safety requirements for industrial robots - Part 1: Robots  
etc.



## **Danger**

**Danger** indicates a hazard with a high level of risk which, if not avoided, will result in death or serious injury.



## **Warning**

**Warning** indicates a hazard with a medium level of risk which, if not avoided, could result in death or serious injury.



## **Caution**

**Caution** indicates a hazard with a low level of risk which, if not avoided, could result in minor or moderate injury.



## **Warning**

### **1. The compatibility of the product is the responsibility of the person who designs the equipment or decides its specifications.**

Since the product specified here is used under various operating conditions, its compatibility with specific equipment must be decided by the person who designs the equipment or decides its specifications based on necessary analysis and test results. The expected performance and safety assurance of the equipment will be the responsibility of the person who has determined its compatibility with the product. This person should also continuously review all specifications of the product referring to its latest catalog information, with a view to giving due consideration to any possibility of equipment failure when configuring the equipment.

### **2. Only personnel with appropriate training should operate machinery and equipment.**

The product specified here may become unsafe if handled incorrectly. The assembly, operation and maintenance of machines or equipment including our products must be performed by an operator who is appropriately trained and experienced.

### **3. Do not service or attempt to remove product and machinery/equipment until safety is confirmed.**

1. The inspection and maintenance of machinery/equipment should only be performed after measures to prevent falling or runaway of the driven objects have been confirmed.
2. When the product is to be removed, confirm that the safety measures as mentioned above are implemented and the power from any appropriate source is cut, and read and understand the specific product precautions of all relevant products carefully.
3. Before machinery/equipment is restarted, take measures to prevent unexpected operation and malfunction.

### **4. Our products cannot be used beyond their specifications. Our products are not developed, designed, and manufactured to be used under the following conditions or environments. Use under such conditions or environments is not covered.**

1. Conditions and environments outside of the given specifications, or use outdoors or in a place exposed to direct sunlight.
2. Use for nuclear power, railways, aviation, space equipment, ships, vehicles, military application, equipment affecting human life, body, and property, fuel equipment, entertainment equipment, emergency shut-off circuits, press clutches, brake circuits, safety equipment, etc., and use for applications that do not conform to standard specifications such as catalogs and operation manuals.
3. Use for interlock circuits, except for use with double interlock such as installing a mechanical protection function in case of failure. Please periodically inspect the product to confirm that the product is operating properly.



# Safety Instructions

## Caution

**We develop, design, and manufacture our products to be used for automatic control equipment, and provide them for peaceful use in manufacturing business.**

**Use in non-manufacturing business is not covered.**

Products we manufacture and sell cannot be used for the purpose of transactions or certification specified in the Measurement Act.

The new Measurement Act prohibits use of any unit other than SI units in Japan.

## Limited warranty and Disclaimer/Compliance Requirements

The product used is subject to the following “Limited warranty and Disclaimer” and “Compliance Requirements”.

Read and accept them before using the product.

### Limited warranty and Disclaimer

1. The warranty period of the product is 1 year in service or 1.5 years after the product is delivered, whichever is first.\*2)  
Also, the product may have specified durability, running distance or replacement parts. Please consult your nearest sales branch.
2. For any failure or damage reported within the warranty period which is clearly our responsibility, a replacement product or necessary parts will be provided.  
This limited warranty applies only to our product independently, and not to any other damage incurred due to the failure of the product.
3. Prior to using SMC products, please read and understand the warranty terms and disclaimers noted in the specified catalog for the particular products.

**\*2) Vacuum pads are excluded from this 1 year warranty.**

A vacuum pad is a consumable part, so it is warranted for a year after it is delivered.

Also, even within the warranty period, the wear of a product due to the use of the vacuum pad or failure due to the deterioration of rubber material are not covered by the limited warranty

### Compliance Requirements

1. The use of SMC products with production equipment for the manufacture of weapons of mass destruction (WMD) or any other weapon is strictly prohibited.
2. The exports of SMC products or technology from one country to another are governed by the relevant security laws and regulations of the countries involved in the transaction. Prior to the shipment of a SMC product to another country, assure that all local rules governing that export are known and followed.

## Operator

- ◆ This operation manual is intended for those who have knowledge of machinery using pneumatic equipment, and have sufficient knowledge of assembly, operation and maintenance of such equipment. Only those persons are allowed to perform assembly, operation and maintenance.
- ◆ Read and understand this operation manual carefully before assembling, operating or providing maintenance to the product.

### ■ Safety Instructions

#### **Warning**

- Do not disassemble, modify (including replacing the circuit board) or repair.  
Otherwise, it can cause an injury or product failure.
- Do not operate the product outside of the specifications.  
Do not use the product with flammable or harmful gases or fluids.  
It may cause fire, malfunction, or damage to the product.  
Check the specifications before use.
- Do not use in an environment where flammable, explosive or corrosive gases are present.  
It may cause fire or an explosion.  
The product is not designed to be explosion-proof.
- Do not use the product with flammable or highly permeable fluids.  
It may cause fire, explosion, damage or corrosion.
- Do not use the product in a place where static electricity is a problem.  
Otherwise, it may cause failure or malfunction of the system.
- If using the product in an interlocking circuit:
  - Provide a double interlocking system, for example, a mechanical protection function using a different system.
  - Check the product for correct operation.Otherwise, it may cause an accident due to malfunction.
- The following instructions must be followed during maintenance:
  - Turn off the power supply.
  - Stop supplying the flow before maintenance.Otherwise, it may cause an injury.

## Caution

- Do not touch the terminals and connectors while the power is on.  
Otherwise, it may cause electric shock, malfunction, and damage to the product.
- After completing maintenance, perform appropriate functional inspections and leak tests.  
Stop operation if the equipment does not function correctly or there is a leakage of fluid.  
When leakage occurs from parts other than the piping, the product might be faulty.  
Disconnect the power supply and stop the fluid supply.  
Do not apply fluid if the system is leaking.  
Otherwise, it may cause an unexpected malfunction and safety cannot be assured.

### ■ Precautions for handling

- Follow the instructions described below for selecting and handling.
  - The instructions on design and selection (installation, wiring, environment, adjustment, operation, maintenance, etc.) described below must be followed.
    - \*Product specifications
      - The direct current power supply used should be UL approved as follows.  
Circuit (Class 2) of maximum 30 [Vrms] (42.4 V peak) or less, with UL1310 Class 2 power supply unit or UL1585 Class 2 transformer.
      - The product is a UL-approved product only if it has a  mark on the product body and label.
      - Use the product within the specified voltage.  
Otherwise, it may cause failure or malfunction.
      - The operating fluid is water (0 to 50 °C).  
Use of fluids other than those mentioned above is not guaranteed.  
Do not use a fluid containing chemicals, synthetic oils including organic solvent, salt, and corrosive gases.  
Mixture of these substances may cause damage or operation failure of the product.
      - Use the product within the specified operating pressure, flow rate, and temperature range.  
Otherwise, it may damage the product, it will not be able to perform proper flow rate control.
      - Take care that pressure exceeding the specified range will not be applied due to water pulsation.  
<Examples of measures for reducing water pulsation>
        - (1) Use a water pulsation-resistant valve.
        - (2) Use elastic piping material such as rubber hose, etc. and an accumulator to absorb impact pressure.
        - (3) Keep the piping length to a minimum.
      - It may be affected by the pulsation of the pump and may destabilize the flow rate measurement and control.  
<Examples of measures for reducing pump pulsation>
        - (1) Install a tank and reduce pulsation.
        - (2) Use elastic piping material such as rubber hose, etc. and an accumulator to absorb pulsation.
      - This product is not suitable for applications to completely cut the flow rate.  
If it is necessary to completely cut the flow rate, install a stop valve, etc. separately.
      - Impurities including metal ions contained in the fluid may be accumulated in the control valve of the product and may cause abnormalities such as valve operation failure. Specifically, do not use copper piping or other piping that tend to have ligation of metal ions.
      - Reserve a space for maintenance.  
Design the system to allow the required space for maintenance.

## ●Product handling

### \*Mounting

- Tighten screws to the specified tightening torque.

If the tightening torque is exceeded, the mounting screws, brackets, the product, and other parts may be damaged. Insufficient torque can cause displacement of the product from its correct position and looseness of the screws. (Refer to Mounting and Installation on page 16).

- If a commercially available switching power supply is used, be sure to ground the frame ground (FG) terminal.

- Do not use where the product is subjected to vibration or impact.

Otherwise, it may damage the internal components and cause malfunction.

- Do not pull the lead wire forcefully or lift the product by the lead wire.

(Tensile strength 49 N or less)

Hold the product body when handling.

Otherwise, it may damage the product and may cause failure and malfunction.

- For piping of the flow controller, hold the piping with a spanner on the metal part of the product only (metal piping attachment).

Holding other parts with a spanner may damage the product.

Specifically, make sure that the spanner does not damage the M12 connector.

This may damage the connector.

- Any dust left in the piping should be flushed out by air blow before connecting the piping to the product.

Otherwise, it can cause damage or malfunction.

- Refer to the fluid flow direction indicated on the product label during installation and piping.

Otherwise, it will be unable to measure accurately.

- Avoid sudden changes to the piping size on the IN side of the product.

If the piping size is reduced or there is a restrictor such as a valve, close to the product on the IN side, the fluid velocity distribution in the piping will be disturbed, leading to improper measurement.

An inner diameter of 9 mm or more is recommended for the piping size of the product on the IN side.

- Do not insert metal wires or other foreign matter into the flow path.

The sensor may be damaged causing failure or malfunction.

- Never mount the product in a place that will be used as a mechanical support.

The product may be damaged if excessive force is applied by stepping or climbing onto it.

- If the fluid may contain foreign matter, install and connect a filter on the IN side.

Accurate measurement may not be obtained if foreign matter has adhered to the vortex generator or vortex detection element of the flow rate sensor unit.

In addition, the adhesion of foreign matter to the valve parts may cause issues with the valve operation. Therefore, the installation of a filter with 150 meshes (100 μm) or more is recommended.

- Design and install the product to keep the internal passage filled with fluid.

- Do not mount the product with the display facing downward.

- When mounting it vertically, the fluid must flow from the bottom to the top.

An accurate measurement may not be obtained when fluid flows from the top to the bottom due to bubbles of entrained air.

(There should not be a problem as long as the fluid passage is completely filled with fluid).

- The product body is made of resin. Do not apply load directly to the body when piping.

Otherwise, it may damage and/or cause water leakage.

\*Wiring (Including connecting/disconnecting the connectors)

- Do not pull hard on the lead wire.

Otherwise it may damage the internal components and cause malfunction or detachment from the connector.

- Avoid repetitive bending, stretching or applying a heavy object or force to the lead wire.

Repetitive bending stress or tensile stress can cause the sheath of the wire to peel off, or breakage of the wires.

If the lead wire is movable, fix it near to the body of the product.

The recommended bend radius of the lead wire is 6 times the outside diameter of the sheath, or 33 times the outside diameter of the insulation material, whichever is larger.

Replace any damaged lead wire with a new one.

- Wire correctly.

Incorrect wiring may cause malfunction or damage to the product.

- Do not perform wiring while the power is on.

Otherwise, it may damage the internal components and cause malfunction.

- Do not route wires and cables together with power lines or high voltage lines.

Route the wires of the product separately from power lines or high voltage lines to prevent noise and surge from entering the signal line.

- Confirm correct insulation of wiring.

Poor insulation (interference with other circuits, poor insulation between terminals, etc.) can apply an excessive voltage or current to the product causing damage.

- Keep wiring as short as possible to prevent interference from noise and surge.

Do not use a cable longer than 30 m.

Wire the DC(-) line (blue) as close as possible to the power supply.

- When an analogue output is used, install a noise filter (line noise filter, ferrite element, etc.) between the switch-mode power supply and the product.



#### \*Operating environment

- Do not use the product in an environment where the product is constantly exposed to water splashes. Otherwise, it may cause failure or malfunction. Take measures such as using a cover.
- Do not use in an atmosphere with corrosive gases, chemicals, sea water, water steam, or where there is direct contact with any of these. Otherwise, it may cause failure or malfunction.
- Do not use the product in a place where the product may be exposed to oil or chemicals. If the product is to be used in an environment containing oils or chemicals such as coolant or cleaning solvent, even for a short time, it may be adversely affected (damage, malfunction, or hardening of the lead wires).
- Do not use in an area where surges are generated. Machines or equipment that generate large surges near the product (electromagnetic type lifter, high-frequency inductive furnace, motor, etc.) may cause deterioration and damage to the internal components. Take protective measures to isolate the surge sources, and prevent the lines from coming into close contact.
- The product is CE/UKCA marked but is not immune to lightning strikes. Take measures against lightning strikes in the system.
- Mount the product in a location that is not affected by vibration or impact. Otherwise, it can cause damage or malfunction.
- Do not use the product in the presence of a magnetic field. Otherwise, it may cause malfunction.
- Do not use the product in an environment that is exposed to temperature cycles. Temperature cycles other than ordinary changes in temperature can adversely affect the internal components of the product.
- Do not expose the product to direct sunlight. If used in a location directly exposed to sunlight, protect the product using a cover. Otherwise, it can cause damage or malfunction.
- Observe the specified operating fluid temperature range and operating temperature range. The fluid temperature range and operating temperature range are 0 to 50°C. Freezing of fluid may cause damage and malfunction of the controller. Take measures to prevent freezing. Fluid with a temperature lower than the ambient temperature may damage the product or cause malfunction due to condensation. Avoid abrupt temperature changes even within the specified temperature range. Otherwise, it can cause damage or malfunction.
- Do not operate close to a heat source, or in a location exposed to radiant heat. Otherwise, it may cause malfunction.

\*Adjustment and operation

- Connect the load before turning the power supply on.
- Do not short-circuit the load.

The product may be damaged due to over-current.

- Check that the system is in the status below when performing flow rate control (at flow rate command input).

- (1) A valve in the same piping is open.
- (2) Operation of a pump, etc. has been started.
- (3) Filled with fluid inside the flow passage of the product.

- The control valve inside the product will be fully opened when the flow rate is insufficient for the controlled flow rate (when closing the valve, when stopping the pump, or other events). This may delay the flow rate setting time when restarting control or may shorten the life when such a condition is repeated. Therefore, turn the power of the product off before the water flow stops when closing the valve or stopping the pump or fix (maintain) the control valve position using the external input function (control stop input).

When starting the flow rate control operation, supply water first to allow starting of the flow rate control and then turn on the power or release the external input (control start).

- The product uses a Karman vortex to measure the flow rate. Karman vortex has the characteristic to have a decrease in flow rate output when the flow rate is excessive, which may disable accurate flow rate detection and flow rate control. (Fig. 1)

Excessive flow rate may be applied when the flow rate is not controlled before turning the power on, depending on the opening of the flow rate control valve inside the product. Therefore, take measures to apply pressure after turning on the power of the product.

In addition, an excessive flow rate may be applied depending on the pressure if the operation of the flow rate control valve stops when using the external input signal (control stop input). Therefore, pay attention to the increase of line pressure when the control is stopped.

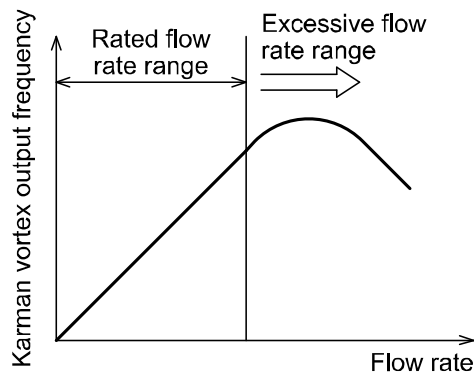

Fig. 1 Output characteristics of the flow rate sensor

\*Maintenance and inspection

- Turn off the fluid supply, turn off the power supply, and confirm safety before performing maintenance and inspections.

Otherwise, it may cause unintended malfunction of system components.

- Perform regular maintenance and inspections.

There is a risk of unexpected failure of components due to the malfunction of equipment and machinery.

- Do not use solvents such as benzene, thinner, etc. to clean the product.

These can damage the surface of the body and erase the markings on the product.

Use a soft cloth to remove stains. For heavy stains, use a damp cloth that has been soaked with diluted neutral detergent and fully squeezed, then wipe up the stains again with a dry cloth.

## Model Indication and How to Order

FC3W5 **04** - **R** **03** - **A1** **C** - **R** **Y**

Rated controlled flow rate range

Symbol	Rated controlled flow rate range
04	0.5 to 4 L/min
20	2 to 16 L/min

Thread type

Symbol	Thread
R	Rc
N	NPT
F	G

Port size

Symbol	Port size	Rated controlled flow rate range	
		04	20
03	3/8	●	●
04	1/2	-	●

Operation manual

Symbol	Operation manual
Y	None
Z	Available

Option 2 (Bracket)

Symbol	Bracket
R	Available
N	None

\*: The bracket is not assembled to the product.  
It is to be shipped together with six mounting screws (3 × 8L).

Option 1 (Lead wire)

Symbol	Cable
C	Lead wire with M12 connector (3 m)
N	None

Input/output specifications

Symbol	IN1	IN2	OUT1
A1	Voltage 1 to 5 V	External input (Stop control)	Voltage 1 to 5 V
A2	Current 4 to 20 mA		Current 4 to 20 mA
A3	Voltage 0 to 10 V		Voltage 0 to 10 V

### Option 1 (Lead wire)

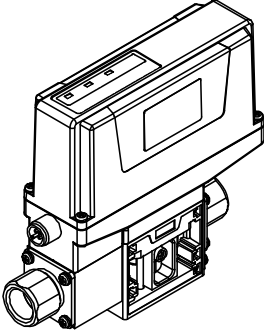
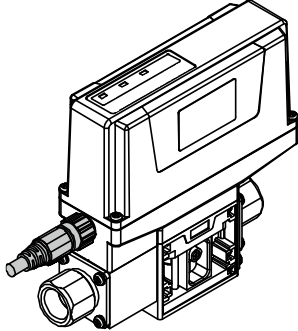
N	C
<p data-bbox="443 376 504 403">None</p> 	<p data-bbox="938 376 1305 439">With lead wire and M12 connector (3 m)</p> 

### Option 2 (Bracket)

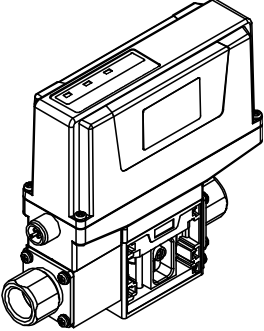
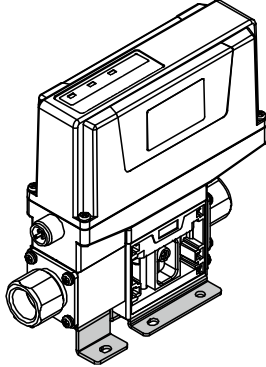
N	R
<p data-bbox="443 936 504 963">None</p> 	<p data-bbox="1050 936 1190 963">With bracket</p>  <p data-bbox="810 1384 1417 1447">The product is shipped together with bracket and 6 self-tapping screws (3 × 8L).</p>

### Accessories/Part numbers

If an accessory is required, order using the following part number.

Part number	Options	Remarks
ZS-53-A	Lead wire with M12 connector	Length: 3 m, 5-core
ZS-54-A	Bracket	Shipped with 6 self-tapping screws 3 × 8L

# Names and Functions of Product Parts

## Body

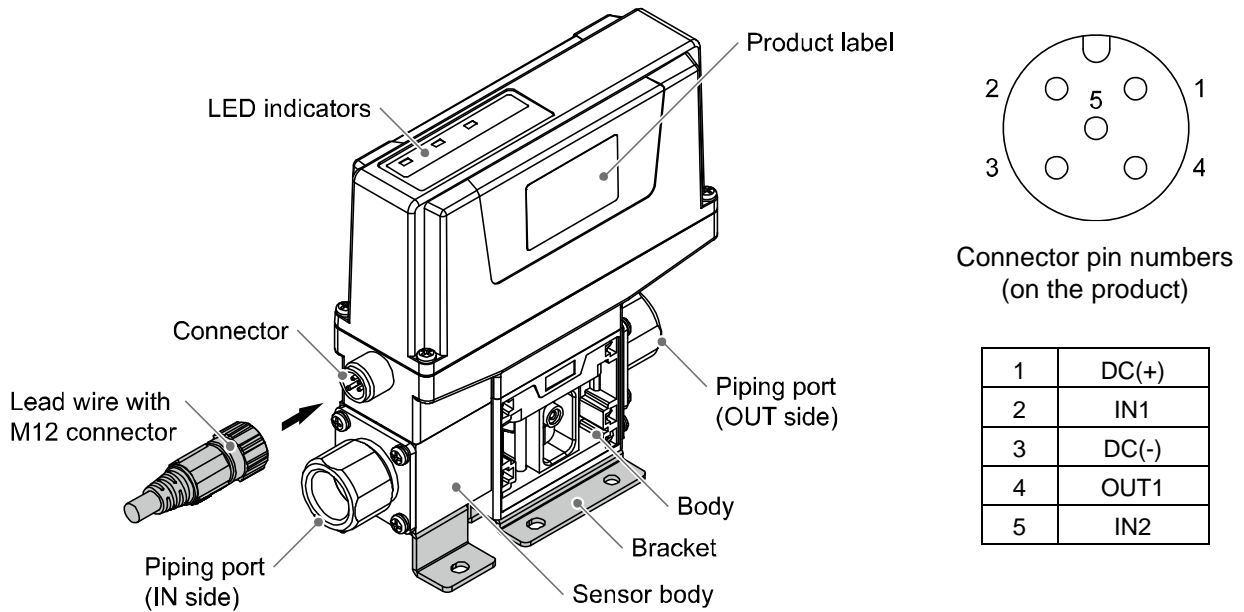

Name	Function
Lead wire with M12 connector	Lead wire to supply power supply voltage, input signal and output signal.
Connector	Connector for lead wire with M12 connector.
Piping port	Piping connections. IN represents inlet and OUT represents outlet.
LED indicators	LED to indicate power supply status, abnormalities, and flow rate control status.
Body	Part of the product comprising the flow path.
Product label	A product label containing information including the product model and flow direction.
Bracket	Mounting bracket for installing the product.

## LED indicators

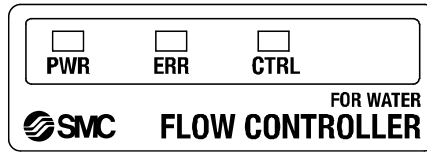

LED	Colour	Status	Explanation	Lighting method
PWR (Power status indicator)	Green	Power supply status	Power supply voltage is supplied to the product.	LED is ON continuously
ERR (Error status indicator)	Red	System error	Abnormality of internal data. *1	LED is ON continuously
		Over-current error	Excessive current is applied to the product. *1	
		Insufficient flow rate	The controlled flow rate does not reach the commanded flow rate.	
		Abnormal power supply voltage	The power supply voltage is lower than about 18 V. *1	
CTRL (Control status indicator)	Green	Control completed	The controlled flow rate is set at within $\pm 5\%$ F.S. of the commanded flow rate.	LED is ON continuously
		Fully closed completed	The control valve is fully closed.	
		During control	The flow rate control is operating aiming for the commanded flow rate.	
		Control stop	The control operation of the control valve is stopped due to the generation of an error or by an external input signal (control stop signal).	LED is OFF

\*1: Stops the control operation. Check the Troubleshooting (page 23) and remove the cause.

## ■ Definition and terminology

	Terminology	Definition
A	Analogue output	Outputs a value proportional to the flow rate. When the analogue output is in the range 1 to 5 V, it will vary between 1 to 5 V according to the change in flow rate. The same for analogue output of 4 to 20 mA.
	Attachment	The metal part of both sides of the product to which piping is connected.
F	Fluid temperature range	Range of fluid temperature that can pass through the product.
	F.S. (full span, full scale)	This means "full span" or "full scale," and indicates the difference between the rated maximum value and minimum value of the product. F.S. of controlled flow rate is the maximum value of the rated controlled flow rate range. F.S. with analogue output when 1 to 5 V output is 4 V (5 V - 1 V). *: The same for analogue output of 4 to 20 mA and 0 to 10 V.
I	Instantaneous flow	The flow rate passing per unit of time. If it is 10 L/min, there is a flow of 10 L passing through in 1 minute.
K	Karman vortex	When an object is placed in a fluid stream, a vortex will be created in the fluid on the downstream side. This is called a Karman vortex. The frequency at which the vortices are generated is proportional to the fluid velocity (flow rate). Therefore, it is possible to calculate the fluid flow rate by measuring the Karman vortex frequency.
M	Min. operational differential pressure	The min. difference between the primary and secondary pressure of the product to satisfy the product specification.
O	Operating humidity range	Humidity range in which the product can operate.
	Operating pressure range	The pressure range in which the product can be used.
	Operating temperature range	Ambient temperature range in which the product can operate.
P	Parts in contact with fluid	A part that comes into physical contact with the fluid.
R	Rated controlled flow rate range	Controlled flow rate range that meets the product specifications.
	Repeatability	The repeatability of the control accuracy or analogue output value when the measured flow quantity is repeatedly increased or decreased.
S	Settling time	Time to set the flow rate to be within $\pm 5\%$ F.S. of the commanded flow rate when an input signal is input. The time when a step signal of 0 → 100% is input is described as the specification of this product.
T	Temperature characteristics	Change in the control accuracy and analogue output when the ambient temperature is changed.
W	Water hammer	Water hammer is a pressure surge due to pressure spread when a fluid in motion is forced to stop or change direction by a switch open/close equipment such as a valve. This pressure surge is called a water hammer or impact pressure.
	Withstand pressure	Pressure limit that if exceeded will result in mechanical and/or electrical damage to the product.

## Mounting and Installation

Check the product specifications before use and operate in an appropriate environment.

### ■ Installation by bracket

Mount the bracket to the product using the self-tapping screw supplied (3 × 8L, 6 pcs.).

(Tightening torque: 1.0 to 1.2 N•m)

Mount on a panel using the product mounting screws (equivalent to M4: 6 pcs.).

Use screws with sufficient length for the bracket plate thickness (1.5 mm).

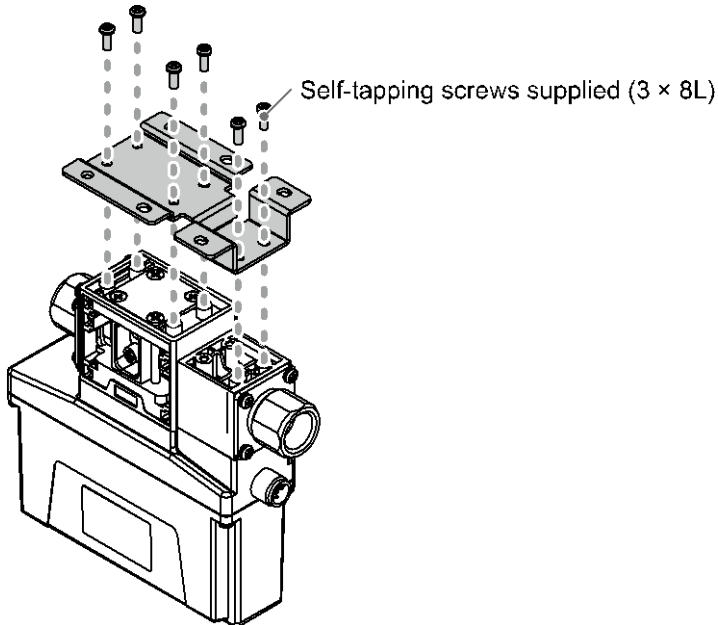

Mounting the bracket

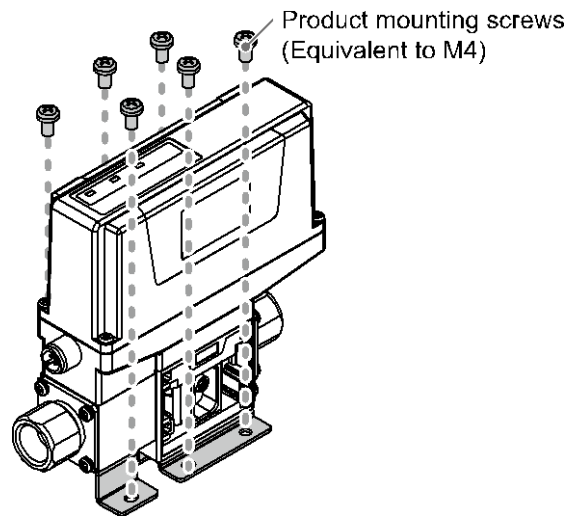

Mounting on a panel

### ■ Direct mounting

For direct mounting, use self-tapping screws (nominal size: 3.0).

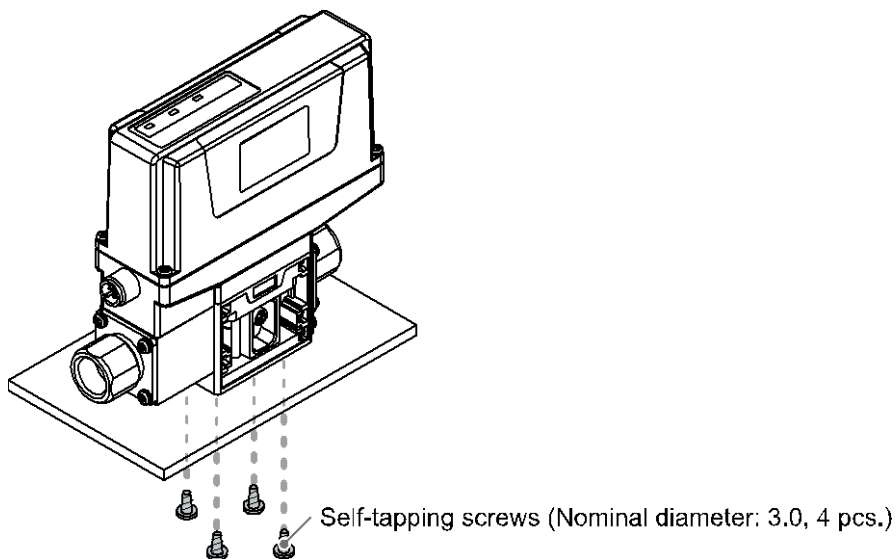



## ■ Piping method

Refer to the fluid flow direction indicated on the product label for installation and piping.  
When piping the product, hold the piping with a spanner on the metal part of the product (metal piping attachment on the piping side). Using a spanner on other parts may damage the product.  
Make sure that the spanner does not impact the connector. Otherwise, it may damage the connector.

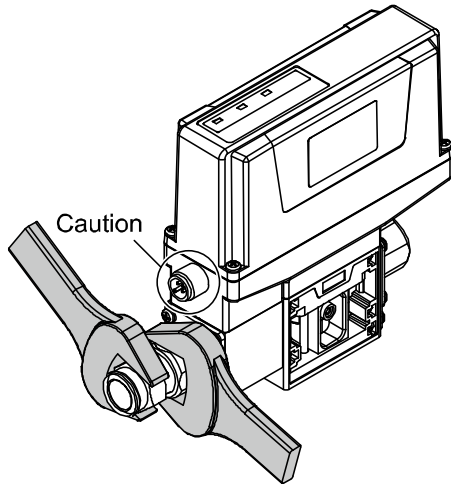

Attachment details

Nominal thread size	Width across flats of attachment
Rc3/8, NPT3/8	20.9 mm
G3/8	23.9 mm
Rc1/2, NPT1/2	23.9 mm
G1/2	26.9 mm

After hand tightening the piping, apply a spanner to the spanner flats on the product, and tighten it for 2 to 3 rotations.

The recommended tightening torque is shown in the table below.

### Guideline for tightening torque

Nominal thread size	Tightening torque
Rc3/8, NPT3/8	15 to 20 N•m
Rc1/2, NPT1/2	20 to 25 N•m

The product may be damaged if the tightening torque is exceeded.  
If the tightening torque is insufficient, the piping may become loose and cause leakage.  
Prevent any sealing tape from getting inside the piping.

## ⚠ Caution

The product body is made of resin. The installation and piping of the product must satisfy the following requirements.

Otherwise, it may damage the product and/or cause water leakage.

- No load should be directly applied to the product.

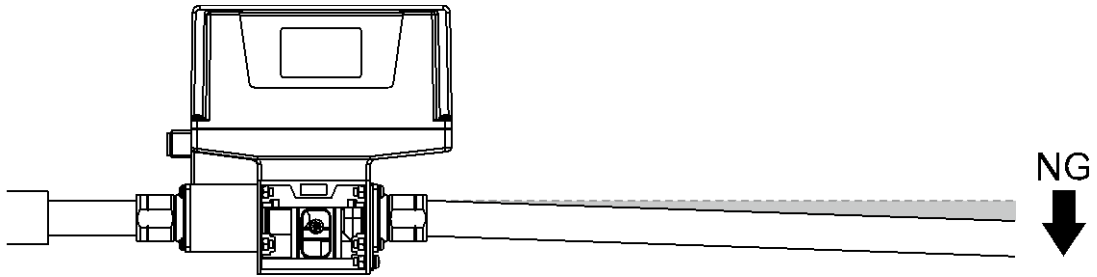

- Do not perform piping when the piping is not aligned.  
A permanent load will be applied to the product after piping.

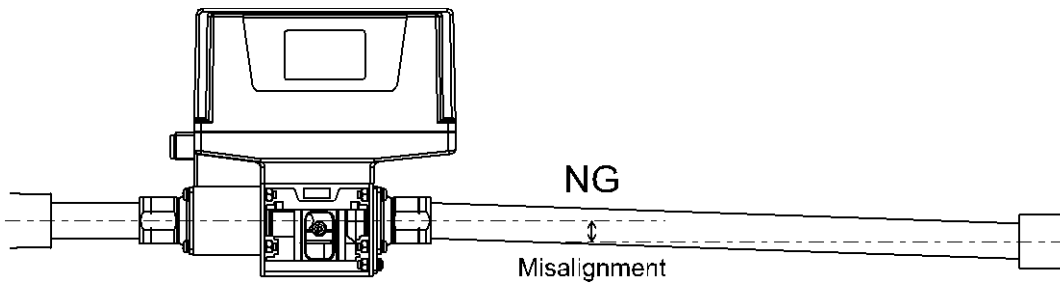

- When a flexible hose is used for the piping, the hose must be fixed with brackets, etc.  
If it is not fixed, the load weight of the flexible hose and the fluid will be applied to the product.

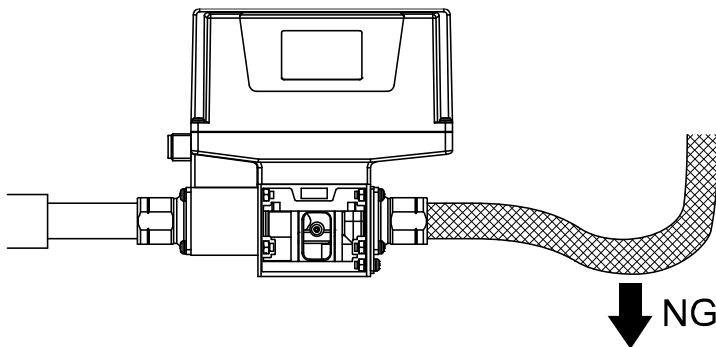

## ■Wiring method

- Connections should only be performed with the power supply turned off.
- Use a separate route for the product wiring and any power or high voltage wiring. Malfunctions stemming from noise may occur if the wire is installed in the same route as that of power lines or high voltage lines.
- If a commercially available switching power supply is used, be sure to connect the frame ground (FG) terminal to ground. If the product is connected to a commercially available switching power supply, switching noise will be superimposed and the product specifications will not be satisfied. In that case, insert a noise filter such as a line noise filter/ferrite between the switching power supply or change the switching power supply to a series power supply.

## ○Connection method

- Align the cable connector key groove with the product connector key to insert and rotate the knurled part of the cable connector.
- Check that the connection is not loose.

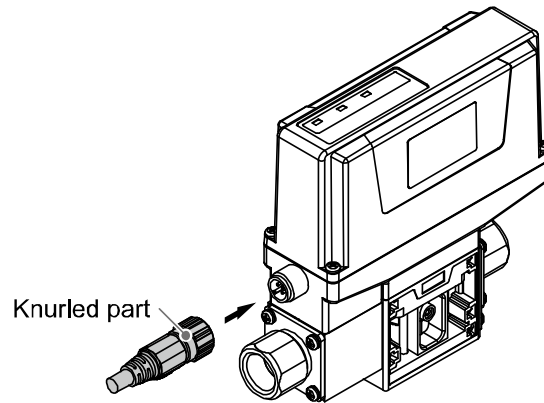

## ○Lead wire and connector

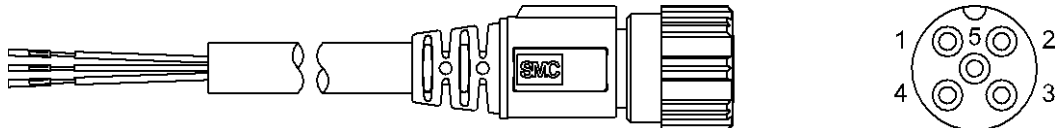

Pin number	Lead wire colour	Name	Explanation
1	Brown	DC(+)	24 VDC
2	White	IN1	Analogue input (Flow rate command input)
3	Blue	DC(-)	0 VDC
4	Black	OUT1	Analogue output (Flow rate output)
5	Grey	IN2	External input (Control stop input) *: Control stops with a Lo input at 0.4 V or less and 30 ms or more *: Hold valve state at signal input

○Internal circuit and wiring

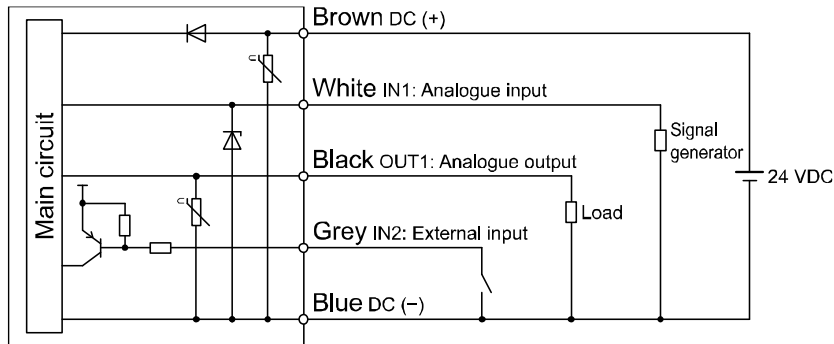

Model	Input/output specifications			
	Name	Function	Specifications	Remarks
FC3W5##-##-A1#-##	IN1	Analogue voltage input	1 to 5 V	Input impedance: approx. 1 MΩ
	OUT1	Analogue voltage output	1 to 5 V	Output impedance: approx. 1 kΩ
	IN2	External input (Control stop input)	Dry contact relay input	0.4 V or less, 30 ms or more
FC3W5##-##-A2#-##	IN1	Analogue current input	4 to 20 mA	Input impedance: 250 Ω or less
	OUT1	Analogue current output	4 to 20 mA	Load impedance: 50 to 600 Ω
	IN2	External input (Control stop input)	Dry contact relay input	0.4 V or less, 30 ms or more
FC3W5##-##-A3#-##	IN1	Analogue voltage input	1 to 10 V	Input impedance: approx. 1 MΩ
	OUT1	Analogue voltage output	1 to 10 V	Output impedance: approx. 1 kΩ
	IN2	External input (Control stop input)	Dry contact relay input	0.4 V or less, 30 ms or more

## ■ Flow rate command input and controlled flow rate

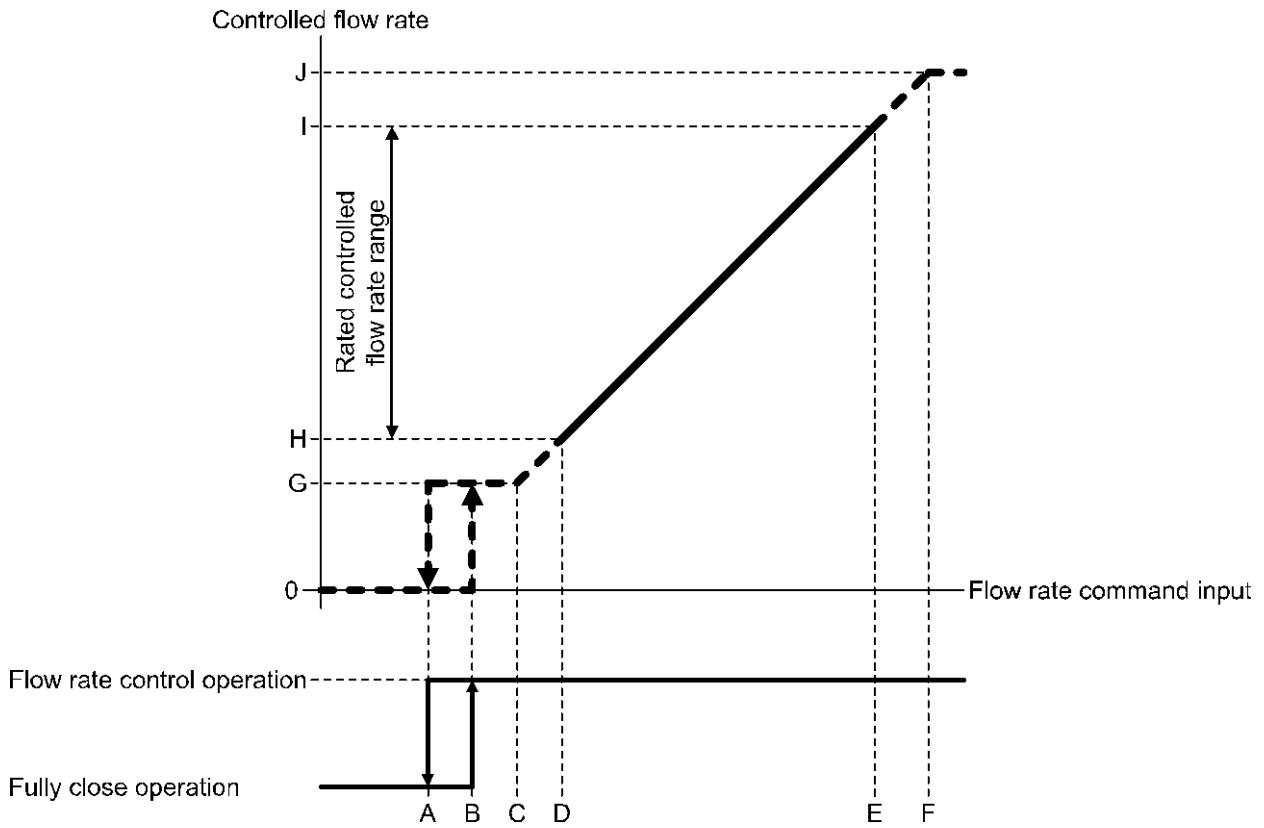

### • Flow rate command input

Symbol	A	B	C	D	E	F
Model						
FC3W5#-A1	1.2 V	1.3 V	1.4 V	1.5 V	5.0 V	5.2 V
FC3W5#-A2	4.8 mA	5.2 mA	5.6 mA	6.0 mA	20.0 mA	20.8 mA
FC3W5#-A3	0.5 V	0.75 V	1.0 V	1.25 V	10.0 V	10.5 V

### • Controlled flow rate

Symbol	G	H	I	J
Model				
FC3W504	0.4 L/min	0.5 L/min	4.0 L/min	4.2 L/min
FC3W520	1.6 L/min	2.0 L/min	16.0 L/min	16.8 L/min

## ■ Controlled flow rate and analogue output

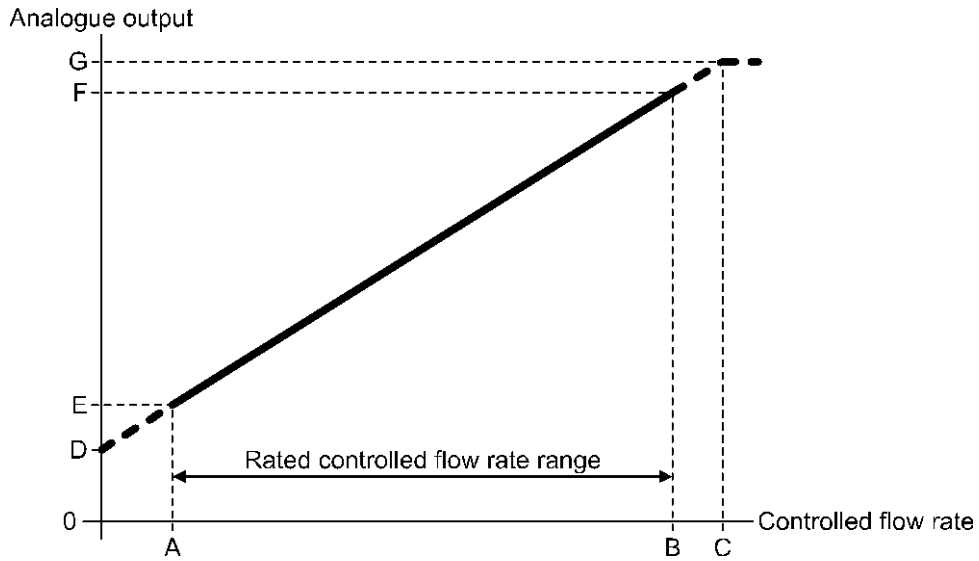

### •Controlled flow rate

Symbol	A	B	C
Model			
FC3W504	0.5 L/min	4.0 L/min	4.2 L/min
FC3W520	2.0 L/min	16.0 L/min	16.8 L/min

### •Analogue output

Symbol	D	E	F	G
Model				
FC3W5#-A1	1.0 V	1.5 V	5.0 V	5.2 V
FC3W5#-A2	4.0 mA	6.0 mA	20.0 mA	20.8 mA
FC3W5#-A3	0.0 V	1.25 mA	10.0 V	10.5 V

## Troubleshooting

Confirm the cause of the problem from the following table when an operation failure of the product occurs. The product itself may be faulty if a cause applicable to the problem cannot be identified and normal operation is recovered by replacement with a new product.

The product may fail depending on the operating environment. Please consult SMC for solutions.

### ● Troubleshooting list

Problem	Possible cause	Investigation method	Countermeasures
Cannot control the flow rate.  Flow does not start.	Abnormal wiring	Check that all wiring is connected properly.	Check and correct the wiring.
	System error	/	Turn off the power supply, check whether there is any noise-generating source, and turn the power supply back on. If the failure cannot be resolved, contact SMC.
	Abnormal power supply voltage	Check the power supply voltage.	Use a power supply voltage of 24 VDC $\pm$ 10%. (The control operation of the product will be stopped forcefully when the power supply voltage drops to about 18 V).
	Application of Lo level voltage to an external input terminal (control stop input)	Check that the voltage applied to the external input terminal (control stop input) is not less than 0.4 V.	Set the external input terminal (grey wire) in open status when starting the control operation.
	Piping connected in the wrong direction	Check that the IN and OUT ports mounting direction of the product matches the flow direction described on the product label.	Install the piping in the correct direction.
	Insufficient flow rate	Check that the pressure has not decreased.	Increase the pressure value to within the rated pressure range to obtain the desired flow rate.
	Water supply shortage	Confirm whether the fluid path is full or not.	Fill the fluid path with fluid.
	Foreign matters in the sensor fluid path	(1) Check for any possibility of entry of foreign matter. (2) Observe inside the flow path of the product from the upstream side and check for any adhesion of foreign matter or discoloration inside the piping.	A filter with filtration of approx. 150 mesh is recommended. Prevent any sealing tape from getting inside the piping.

Problem	Possible cause	Investigation method	Countermeasures
Cannot control the flow rate.  Flow does not start.	Operation failure due to accumulation of foreign matter inside the valve (adhesion)	(1) Check for any possibility of entry of foreign matter. (2) Observe inside the flow path of the product from the upstream side and check for any adhesion of foreign matter or discoloration inside the piping.	When using copper piping, etc., liquation of copper ions may occur within the fluid depending on the operating environment and may cause operation failure when fully closed because the valve with an accumulation of copper ions may get adhered to the orifice inside. Therefore, take measures including changing the piping material.
	Abnormal control valve over-current	Check if there is a power line or a high voltage line that generates noise in the wiring route.	Turn off the power supply, check whether there is any noise-generating source, and turn the power supply back on. If the failure cannot be solved, contact SMC.
	Effect of pump pulsation	When the internal flow rate sensor malfunctions due to pulsation, the valve may not open even when the flow rate command is input in a fully closed condition.	Take the measures described below when affected by pump pulsation. •Change the pump •Mitigate pulsation by installing a tank •Mitigate pulsation using an accumulator or rubber hose



Problem	Possible cause	Investigation method	Countermeasures
The analogue output cannot be output.  Unstable analogue output.	Abnormal wiring	Check that each wire is connected correctly.	Check and correct the wiring.
	System error		Turn off the power supply, check whether there is any noise-generating source, and turn the power supply back on. If the failure cannot be resolved, contact SMC.
	Foreign matter in the sensor fluid path	(1) Check for any possibility of entry of foreign matter. (2) Observe inside the flow path of the product from the upstream side and check for any adhesion of foreign matter or discoloration inside the piping.	A filter with filtration of approx. 150 mesh is recommended. Prevent any sealing tape from getting inside the piping.
	Effect of pump pulsation	It may be affected by pump pulsation when the analogue output is fluctuating unstably.	Take the measures described below when affected by pump pulsation. •Change the pump •Mitigate pulsation by installing a tank •Mitigate pulsation using an accumulator or rubber hose
	Noise	Check if there is a power line or a high voltage line that generates noise in the wiring route.	Route signal wiring separately from power lines and high voltage lines.
External input (control stop input) not accepted.	Abnormal wiring	Check that all wiring is connected correctly.	Check and correct the wiring
	System error		Turn off the power supply, check whether there is any noise-generating source, and turn the power supply back on. If the failure cannot be resolved, contact SMC.
	Input time is short Input voltage is high	Check whether the potential of 0.4 V or less can be maintained with the grey line for 30 ms or more.	When applying external input, connect to a potential of 0.4 V or less for 30 ms or more.

# Specifications

Model		FC3W504	FC3W520
Fluid spec.	Applicable fluid	Water	
	Fluid temperature range	0 to 50 °C (No condensation or freezing)	
Flow rate spec.	Flow rate detection method	Karman vortex	
	Rated controlled flow rate range *1	0.5 to 4.0 L/min	2.0 to 16.0 L/min
	Leakage when fully closed *2	0.4 L/min or less	1.0 L/min or less
Control spec.	Control accuracy *3	±5%F.S.	
	Control dead zone *4	Reach in the range of ±2%F.S. of the commanded flow rate	
	Repeatability	±3%F.S.	
	Temperature characteristics	±5%F.S. (0 to 50 °C, Reference 25 °C)	
	Setting time *5	Within the range of ±5%F.S. of the commanded flow rate within 10 seconds	
Operation when power supply is not connected *6	Hold valve state		
Pressure spec.	Operating pressure range *7	0.2 to 0.4 MPa	
	Minimum operating differential pressure	0.2 MPa	
	Withstand pressure	0.6 MPa	
Analogue input *8 (Flow rate command)	Voltage	Input type	1 to 5 VDC/0 to 10 VDC
		Input impedance	Approx. 1 MΩ
	Current	Input type	4 to 20 mADC
		Input impedance	250 Ω or less
Analogue output (Flow rate output)	Voltage	Output type	1 to 5 VDC/0 to 10 VDC
		Output impedance	Approx. 1 kΩ
	Current	Output type	4 to 20 mADC
		Output impedance	50 to 600 Ω
External input (Control stop input)	Input type	Dry contact relay input (0.4 V or less), input time: 30 ms or more	
	Operation	Flow rate control operation stop (Hold valve state)	
Electrical spec.	Power supply voltage	24 VDC ±10%	
	Current consumption *9	0.1 A or less (At control stop and control setting) 0.5 A or less (During control operation)	
Operation LED		PWR (Green): Power supply status indication ERR (Red): Error status indication CTRL (Green): Control status indication	

Model		FC3W504	FC3W520
Environmental resistance	Enclosure rating	IP65 (IEC 60529)	
	Operating temperature range	0 to 50 °C (No condensation)	
	Operating humidity range	Operation and storage: 35 to 85%R.H. (No condensation)	
	Withstand voltage	1000 VAC for 1 minute between terminals and housing	
	Insulation resistance	50 MΩ or more between terminals and housing (with 500 VDC megger)	
Standards		CE/UKCA marked	
Materials in contact with fluid		FKM, Stainless steel 303/304, PP+PE, POM, PPS	
Piping specifications		3/8 (Rc, NPT, G)	3/8, 1/2 (Rc, NPT, G)
Weight	Body	Approx. 480 g	Approx. 500 g
	Bracket	Approx. 50 g	
	Lead wire (3 m)	Approx. 180 g	

- \*1: Operation may become unstable when it is outside the rated controlled flow rate range.
- \*2: This product is not suitable for applications to completely cut (stop) the flow rate.  
If it is necessary to completely cut the flow rate, install a stop valve, etc. separately.
- \*3: Includes a control dead zone of  $\pm 2\%$ F.S.
- \*4: When the controlled flow rate falls within the range of the commanded flow rate  $\pm 2\%$ F.S. (control dead zone), the control operation halts.
- \*5: The condition is the step change of the commanded flow rate in the range from 0% to 100% at an operating pressure of 0.3 MPa.  
The settling time may be delayed in other conditions.
- \*6: The control valve operation stops and the valve opening will be maintained when the power supply is turned OFF.
- \*7: Normal control operation may not be available when it is outside the operating pressure range.
- \*8: The product will perform a fully closed operation when the analogue input terminal is in open status (signal is not input).
- \*9: Current consumption higher than the actual use may be present when abnormalities of control operation such as no supply pressure occurs.
- \*10: Any products with tiny scratches, smears, or variations in the display colour or brightness, which does not affect the performance of the product, are verified as conforming products.

#### ○ Cable specification

Conductor	Nominal cross section	AWG21
	Outside diameter	Approx. 0.9 mm
Insulator	Outside diameter	Approx. 1.7 mm
Sheath	Material	PVC
Finished outside diameter		$\phi 6$ mm
Min. bending radius		60 mm

#### ● Pressure loss

FC3W504-#

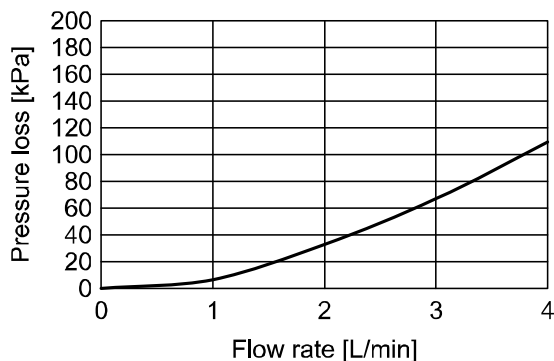

FC3W520-#

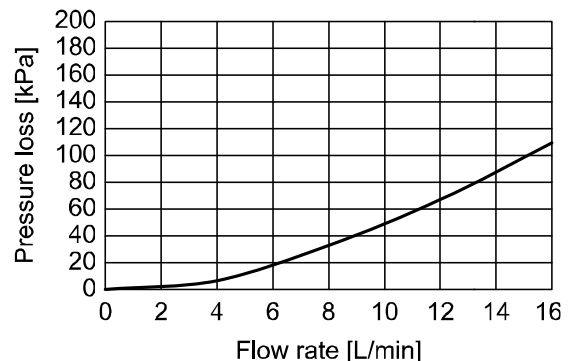

## ■ Outline dimensions

- FW3W504/520-#03
- FW3W520-#04

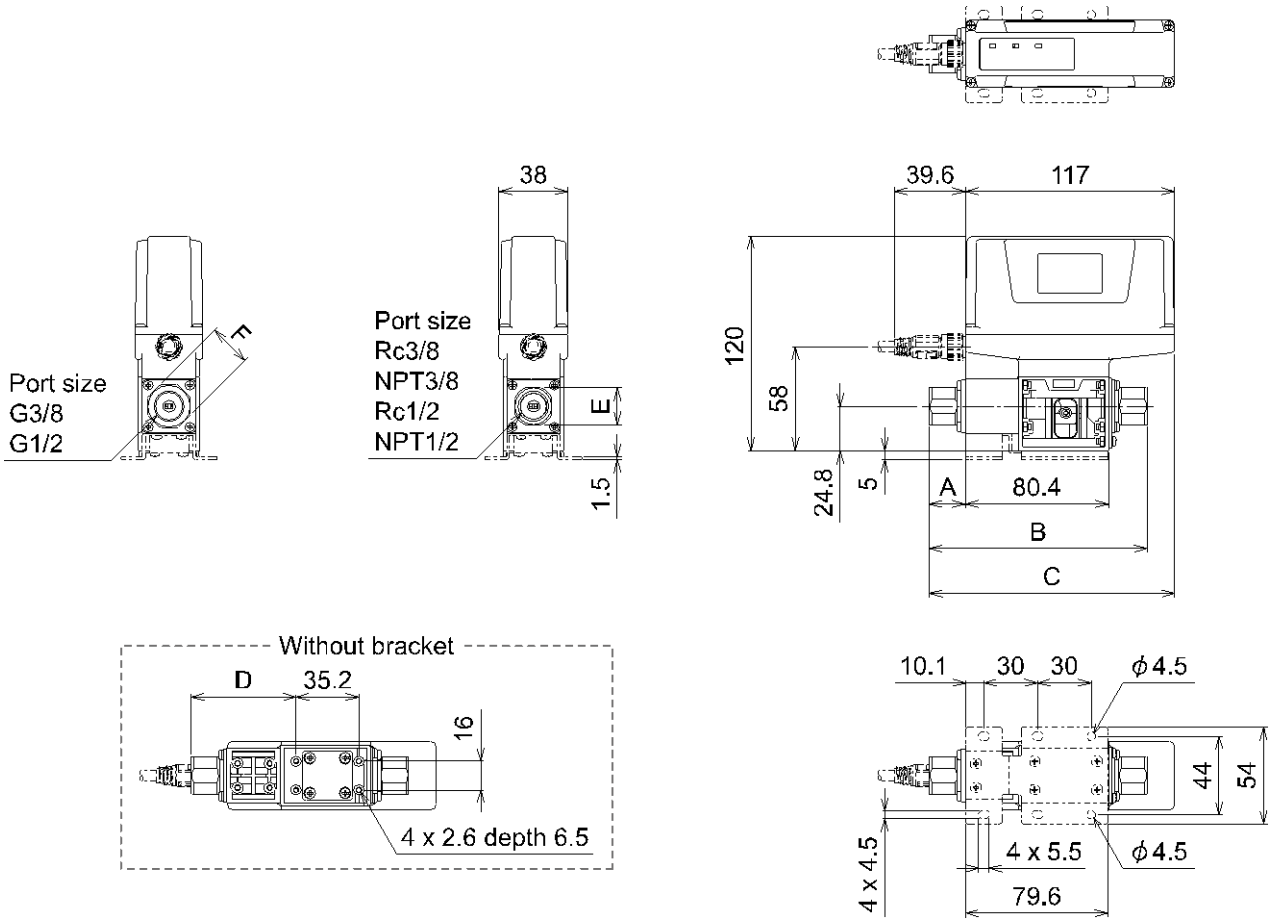

(mm)

Model	Port size	A	B	C	D	E	F
FC3W504-R03-#	Rc3/8	20	121.9	137.2	58.8	20.9	-
FC3W504-N03-#	NPT3/8	20	121.9	137.2	58.8	20.9	-
FC3W504-F03-#	G3/8	20	121.9	137.2	58.8	-	23.9
FC3W520-R03-#	Rc3/8	24	129.9	141.2	62.8	20.9	-
FC3W520-N03-#	NPT3/8	24	129.9	141.2	62.8	20.9	-
FC3W520-F03-#	G3/8	24	129.9	141.2	62.8	-	23.9
FC3W520-R04-#	Rc1/2	24	129.9	141.2	62.8	23.9	-
FC3W520-N04-#	NPT1/2	24	129.9	141.2	62.8	23.9	-
FC3W520-F04-#	G1/2	24	129.9	141.2	62.8	-	26.9

■ Lead wire with M12 connector

• ZS-53-A

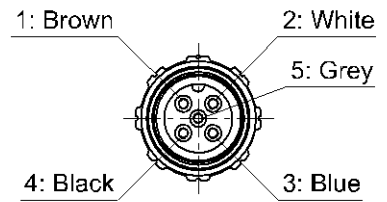
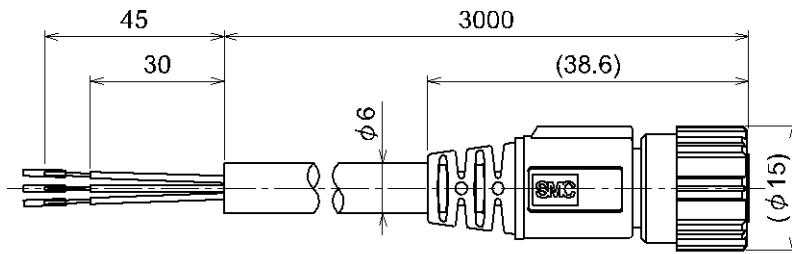

5-pin Socket A-coded  
(Normal key)

Revision history
------------------

## SMC Corporation

4-14-1, Sotokanda, Chiyoda-ku, Tokyo 101-0021 JAPAN

Tel: + 81 3 5207 8249 Fax: +81 3 5298 5362

URL <https://www.smcworld.com>

---

Note: Specifications are subject to change without prior notice and any obligation on the part of the manufacturer.  
© 2023 SMC Corporation All Rights Reserved

