

Quick Manual

Thermo-chiller

HRS series

Contents

Read before using
Safety Instructions

1. Name of Parts and Accessories
2. Transportation, Transfer and Moving
3. Mounting and Installation
4. Piping
5. Filling of Circulating Fluid
6. Wiring of Power Supply
7. Start, Stop and Temperature Setting
8. How to Reset Alarms
9. Alarm Code List

Before requesting service

Read before using

Thank you for purchasing SMC's thermo-chiller (hereinafter referred to as the "product"). This "Quick Manual" (hereinafter referred to as this "manual") briefly explains the procedures to start and stop the product and reset its alarms. Read this manual as well as the Operation Manual attached before using.

Safety Instructions

- Read and understand Safety Instructions carefully for proper use.
- In these instructions, warning indicates a hazard with a medium level of risk which, if not avoided, could result in death or serious injury. Caution indicates a hazard with a low level of risk which, if not avoided, could result in minor or moderate injury. Make sure to follow every instruction since they are important for safety.
- The symbols used in this manual have the following meanings.

	Don'ts		Dos
--	--------	--	-----

Warning

- Do not service machinery/equipment or attempt to remove the product until safety is confirmed. In particular, before restarting the product, ensure that safety measures are taken.
- The compatibility of the product is the responsibility of the person who designs the equipment or decides its specifications.
- Only personnel with appropriate training should operate machinery and equipment.
- The product can be dangerous when handled incorrectly.
- The piping, wiring, operation and maintenance of machines or equipment using this product must be performed by an operator who is appropriately trained and experienced.
- When the product is installed on equipment in conjunction with atomic energy, railways, air navigation, space, vehicles, medical treatment, or equipment in contact with food and beverages, or used for applications which could have negative effects on people, property, or animals requiring special safety analysis, give consideration to safety measures and contact SMC beforehand.

⚠ Caution	
	<ul style="list-style-type: none"> • Do not use the product outdoors. If the product is subjected to rain or water splash it may cause electrical shock, fire or failure. • Do not use the product in an area of high temperature and humidity which cannot be exhausted, or where it is exposed to corrosive substances. Cooling failure can result. • Do not handle the power supply connector and switch with wet hands. Electrical shock can result.
	<ul style="list-style-type: none"> • Read the catalog and Operation Manual carefully. Keep to the specified procedures and within specified ranges. • This product is heavy (over 40kg). When transferring the product with casters or handles, pay attention to slopes on the route and the risk of dropping the product. • Select piping applicable to the operating pressure range. Otherwise, it can cause fluid leakage or rupture. • Use fresh water or ethylene glycol aqueous solution (concentration of 15% or less) as the circulating fluid. • For the precautions for handling the circulating fluid, get the Material Safety Data Sheet from the manufacturer and read it.

1. Name of Parts and Accessories

- Check the enclosed accessories with the delivered thermo-chiller.

Accessories			
1	Quick manual (this manual)		1 (with a clear cover)
2	Alarm code list label		1
3	Operation Manual		1
4	Power supply connector		1
5	Sequence I/O command signal connector*		1
6	Fitting (for drain port)*		1
7	Ferrite core*		1

*These accessories are not explained in this manual. For details, read the Operation Manual attached.

- The names of parts used in this manual are as follows.

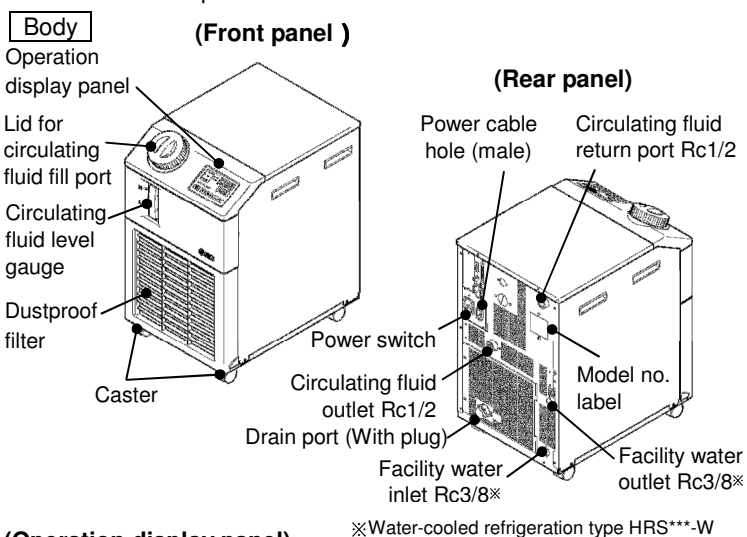

(Operation display panel)

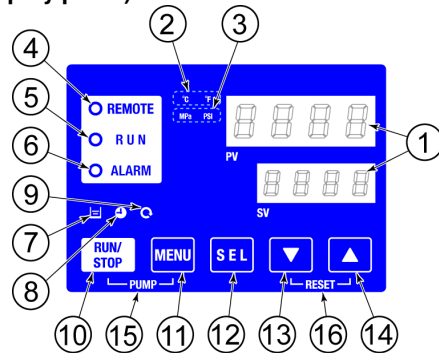

No	Description	Function	
1	Digital display (7-segment, 4 digits)	PV	Displays the temperature and pressure of the circulating fluid and alarm codes.
		SV	Displays the discharge temperature of the circulating fluid and the set values of other menus.
2	[°C] [°F] lamp	Equipped with a unit conversion function. Displays the unit of display temperature (default setting °C).	
3	[MPa] [PSI] lamp	Equipped with a unit conversion function. Displays the unit of display pressure (default setting MPa).	
4	[REMOTE] lamp*	Enables the remote operation (start and stop) by communication. Lights up during remote operation.	
5	[RUN] lamp	Lights up when the product is started and in operation. Goes off when the product is stopped. Flashes during stand-by for stop or anti-freezing function, or independent operation of the pump.	
6	[ALARM] lamp	Flashes with buzzer when alarm occurs.	
7	[] lamp	Lights up when the surface of the level indicator falls below the LOW level.	
8	[] lamp*	Lights up while the run timer or stop timer function is working.	
9	[] lamp*	Lights up when the product is in automatic operation.	
10	[RUN/STOP] key	Makes the product start or stop.	
11	[MENU] key*	Shifts the main menu (display screen of temperature) and secret menu (entry of set values and monitor screen).	
12	[SEL] key*	Changes the item in menu and enters the set value.	
13	[▼] key	Decreases the set value.	
14	[▲] key	Increases the set value.	
15	[PUMP] key	Keep the [MENU] and [RUN/STOP] keys pressed down simultaneously. The pump starts running independently to make the product ready for start-up (release the air).	
16	[RESET] key	Keep the [▼] and [▲] keys pressed down simultaneously. This will stop the alarm buzzer and reset the [ALARM] lamp.	

*These lamps and keys are not used in this manual. For details, read the Operation Manual attached.

2. Transportation, Transfer and Moving

- 1) Be sure to unlock the caster (only at the front wheel). There is no lock function with the rear casters.
- 2) Push the left and right panels with the handle and move.
- 3) Use corners when pushing the front or rear panel. Pushing at the center can deform the panel.

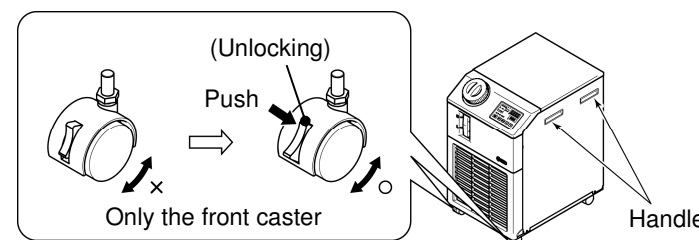

3. Mounting and Installation

- 1) Select a flat place applicable to the weight of the product for moving.
- 2) Install the product so that there are no obstacles in the work space for setting up and servicing, or blocking the radiation at the inlet and outlet of ventilation.

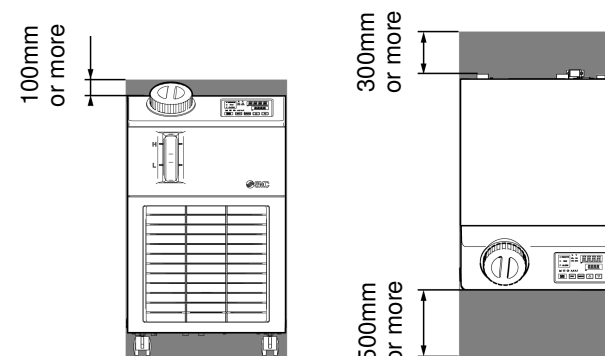

- 3) After moving, lock the caster at the front wheel again.
- 4) Fix the product to the floor or base using the anti-quake bracket (prepared separately).

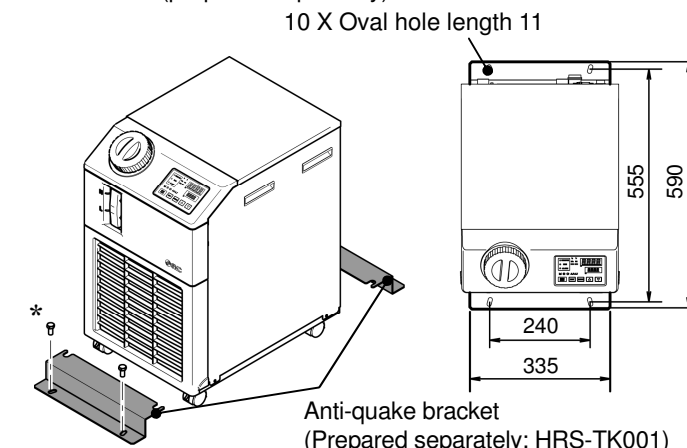

*The Anchor bolts are not attached. To be prepared by the user.

4. Piping

- 1) Connect the circulating fluid return port with the user's machine outlet.
- 2) Connect the circulating fluid discharge port with the user's machine inlet.

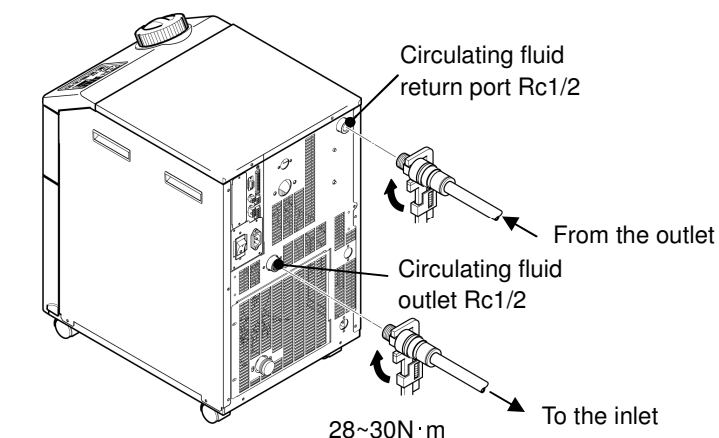

<Water-cooled refrigeration type HRS***-W>

- 1) Connect the facility water inlet with the user's water source outlet.
- 2) Connect the facility water outlet with the user's water source inlet.

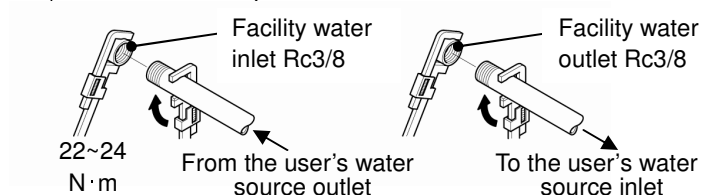

5. Filling of Circulating Fluid

- 1) Check the drain port is plugged or closed by the valve to prevent the supplied circulating fluid from draining out.
- 2) Turn the lid for the circulating fluid fill port counterclockwise to open, and fill the circulating fluid up to "H" of the level indicator scale.
- 3) After filling to the specified level, turn the lid clockwise to close.

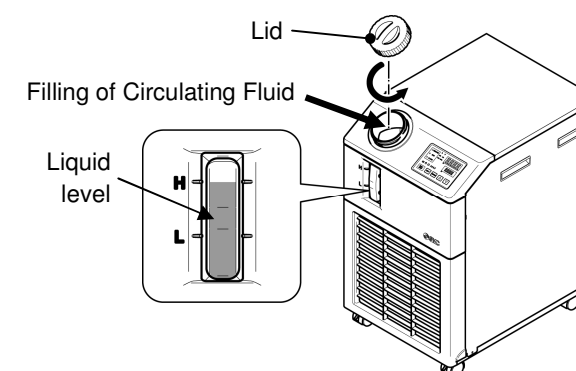

6. Wiring of Power Supply

Warning

- The electrical facilities should be installed and wired in accordance with local laws and regulations of each country and by the person who has knowledge and experience.
- Check the power supply. Operation with voltages, capacities, frequencies and cable sizes other than those specified can cause heat, fire and electrical shock.
- Wire with an applicable cable size and terminal.

Caution

- Use an individual socket or earth leakage breaker.
- Be sure to provide grounding. Incomplete grounding can cause failure and electrical shock.

Preliminary preparation for wiring.

- Prepare the cable and individual socket or earth leakage breaker shown in the table below.
- Strip the sheath from both ends of the cable.
- Disassemble the power supply connector (supplied as an accessory) and mount one end of the cable to the L, N and E terminals and reassemble the power supply connector.
- Connect the other end of the cable to a plug or crimped terminal that is connectable to the secondary side of the earth leakage breaker.

HRS model	Power supply voltage	Rated voltage [V]	Rated current [A]	Sensitivity of leak current [mA]	Cable qty. x size
HRS012-**-10 HRS018-**-10	1-phase 100V AC (50/60Hz) 1-phase 115V AC (60Hz)	Recommended earth leakage breaker			3 cores x 14AWG (3 cores x 2.0mm ²) *including ground
		100 200 Sharing	15	15 or 30	
Recommended plug					
125	15	-			
HRS012-**-20 HRS018-**-20 HRS024-**-20	1-phase 200-230V AC (50/60Hz)	Recommended earth leakage breaker			
			10	30	
HRS0**-**-20- **T (If option 【high head pump】 is used.)	1-phase 200-230V AC (50/60Hz)	200, 230	15	30	

Wiring of power supply

- Insert the power supply connector to the power cable hole.
- Connect the plug or crimped terminal to the individual grounded socket or the secondary side of the earth leakage breaker and grounding.
- Turn on the breaker, etc. of the facility power supply and energize the product.

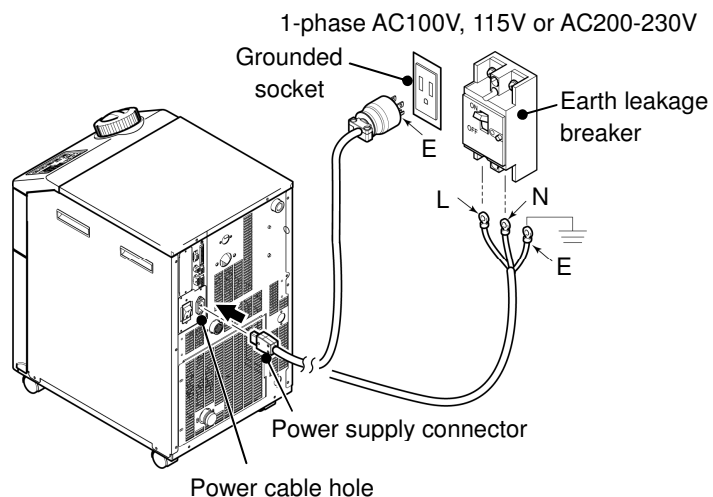

7. Start, Stop and Temperature Setting

Preliminary preparation for start-up.

Supply of power

- Turn on the power switch.

→The initial screen (HELLO) will be displayed for approx. 8 seconds on the operation panel, and changed to the display of the circulating fluid discharge temperature (main menu).

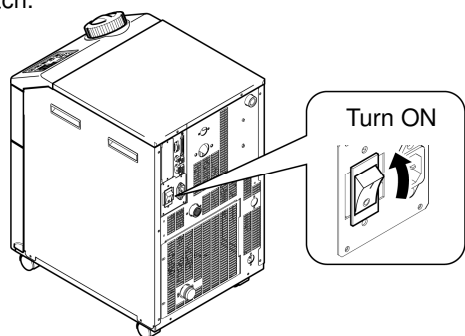

Air release

- Press the [PUMP] key ([RUN/STOP] key and [MENU] key simultaneously). The [RUN] lamp flashes and only the pump continues to operation. This operation allows the discharge of the circulating fluid, and enables checking leakage from the piping and air release.
- At this time, the fluid level can lower and cause the alarm "AL01; Low tank level", which will lead to the stop of the product.
- In that case, check that there is no leakage from the user's piping, fill the circulating fluid as specified in "5.Filling of Circulating Fluid" and take necessary actions in "8.How to Reset Alarms".
- Repeat steps 1) to 3) until the alarm ("AL01; Low tank level") is no longer generated.

Temperature setting

- Press the [▼] and [▲] keys to change the SV to the required value.

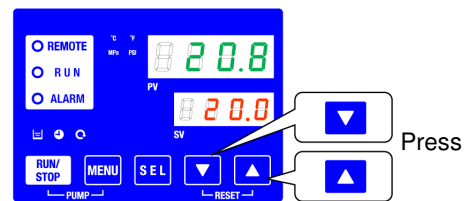

(e.g.) "Set value of circulating fluid discharge temperature" 20.0oC (Default value)

Start of the product

- Keep the [RUN/STOP] key pressed for approx. 2 seconds.
→The [RUN] lamp lights up (in green) and the product starts running. The circulating discharge temperature (PV) is controlled to the set temperature (SV).

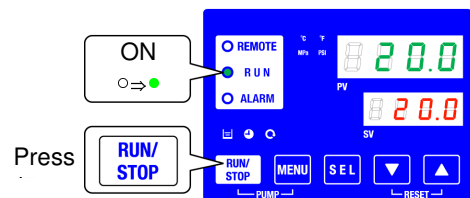

Stop of the product

- Keep the [RUN/STOP] key pressed for approx. 2 seconds.
→The [RUN] lamp flashes (in green) and continues the operation until the product is ready to stop. After approx. 10 seconds, the [RUN] lamp goes off and the product stops.

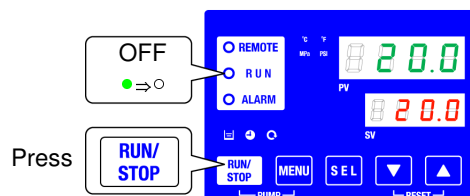

8. How to Reset Alarms

Caution

- Should some error occur, the [ALARM] lamp flashes (in red) and the buzzer sounds to inform the user of the error. Also, the alarm code will be displayed on the operation panel so that the cause can be checked on "9. Alarm Code List".

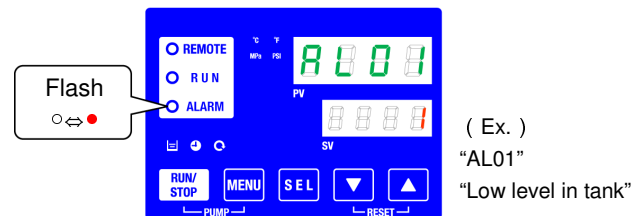

- Before resetting the alarm, read the "Cause and Remedy" of "9. Alarm Code List" and eliminate the cause explained there. Otherwise, the same alarm may be repeated.
- As accessories, the clear cover (for this manual) and alarm code list label are enclosed. Stick the label to the panel to check the content of alarm codes.

Reset of alarm

- Press the [RESET] key ([▼] and [▲] keys simultaneously).
→The buzzer and then [ALARM] lamp (red) go off.

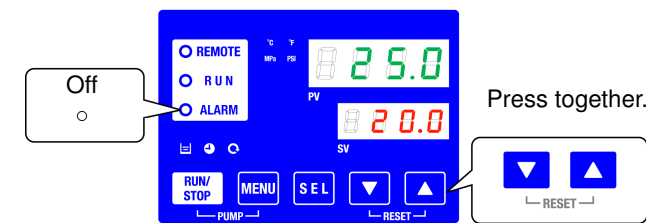

Before requesting service

Should some error occur, the user will be informed by the alarm (for warning). Check the cause and restart the product after eliminating it. If the same alarm is repeated frequently, or multiple alarms occur at the same time, which is obviously abnormal compared to the past performance of the product, contact the retailer or SMC sales representative where you purchased the product.

SMC Corporation

Address : 4-14-1 Sotokanda, Chiyoda-ku, Tokyo 101-0021, Japan
TEL : +81 3 5207 8249 FAX : +81 3 5298 5362
URL : <http://www.smcworld.com>

This manual is subject to change without prior notice.

9. Alarm Code List

Alarm code	Description	Operation	Cause / Remedy (Press the reset key after eliminating the cause.)
AL01	Low level in tank	Stop ^{*1}	The fluid level has fallen below the level indicator. Fill the circulating fluid.
AL02	High circulating fluid discharge temp.	Stop	- Reduce the ambient temperature or heat load.
AL03	Circulating fluid discharge temp. rise	Continued ^{*1}	- Wait until the temperature decreases.
AL04	Circulating fluid discharge temp. drop	Continued ^{*1}	Check the ambient temperature condition and the temperature of supplied circulating fluid.
AL05	High circulating fluid return temp.	Stop	- Check the circulating fluid flows. - Check the heat load are within the specified range.
AL06	High circulating fluid discharge pressure	Stop	Check the user's piping for bends, squash and foreign matters.
AL07	Abnormal pump operation	Stop	Restart and check the pump is operating.
AL08	Circulating fluid discharge pressure rise	Continued ^{*1}	Check the user's piping for bends, squash and foreign matters.
AL09	Circulating fluid discharge pressure drop	Continued ^{*1}	Restart and check the pump is operating.
AL10	High compressor intake temp.	Stop	Check the temperature of the circulating fluid returning to the product.
AL11	Low compressor intake temp.	Stop	- Check the circulating fluid flows.
AL12	Low super heat temperature	Stop	- Check the circulating fluid in the evaporator has not frozen.
AL13	High compressor discharge pressure	Stop	Reduce the ambient temperature or heat load.
AL15	Refrigerant circuit pressure (high pressure side) drop	Stop	Check the ambient temperature is within the specified range.
AL16	Refrigerant circuit pressure (low pressure side) rise	Stop	Reduce the ambient temperature or heat load.
AL17	Refrigerant circuit pressure (low pressure side) drop	Stop	Check the circulating fluid flows.
AL18	Compressor overload	Stop	Leave for 10 minutes and restart, and check the compressor is operating.
AL19 ^{*2}	Communication error ^{*2}	Continued ^{*1}	The request message from the host computer has not arrived. Send it again.
AL20	Memory error	Stop	Written data is different from read data. Ask for the service of RAM.
AL21	DC line fuse cut	Stop ^{*1}	Ask for the service of the fuse of the DC circuit.
AL22	Circulating fluid discharge temp. sensor failure	Stop	The temperature sensor is short-circuited or opened. Ask for the service of the temperature sensor.
AL23	Circulating fluid return temp. sensor failure	Stop	
AL24	Compressor intake temp. sensor failure	Stop	
AL25	Circulating fluid discharge pressure sensor failure	Stop	The pressure sensor is short-circuited or opened. Ask for the service of the pressure sensor.
AL26	Compressor discharge pressure sensor failure	Stop	
AL27	Compressor intake pressure sensor failure	Stop	
AL28	Maintenance of pump	Continued	The timing of a periodical check is informed.
AL29 ^{*3}	Maintenance of fan motor ^{*3}	Continued	Recommended to ask for the check and service of the pump, fan motor and compressor.
AL30	Maintenance of compressor	Continued	
AL31 ^{*2}	Contact input1 Signal detection	Stop ^{*1}	Contact input is detected.
AL32 ^{*2}	Contact input2 Signal detection	Stop ^{*1}	

*1 "Stop" or "Continued" are default setting. The user can changed to "Continued" and "Stop". For details, read the Operation Manual attached.

*2 "AL19, AL31, AL32" is disabled in the default setting. When this function needs to be enabled, refer to the Operation Manual attached.

*3 HRS***-A** (Air-cooled refrigeration type).

*4 Refer to the "Operation Manual" (separate sheet) for other alarms.