



Operation Manual

PRODUCT NAME

Suction cups with flange

MODEL / Series / Product Number

ZXP7-PFL1-ZP**-X1***

The outward appearance showed on this manual is an example of the suction cups with flange which is indicated by the product number: ZXP7-PFL1-ZPB25JS-X1. Refer to the suction cup catalog for the detail of other applicable suction cups.

SMC Corporation

Contents

Safety Instructions	2
1. Parts included in the package.....	4
2. Names of Parts of the Product.....	5
3. Specifications	6
3.1. Specifications	6
3.2. How to calculate theoretical lifting force	6
3.3. How to order	7
4. Mounting	8
4.1. Mounting	8
4.3. Piping	9
5. Dimensions.....	10
5.1. Suction cups with flange	10
5.2. Center of gravity (ZXP7-PFL1-ZPB25JN-X1)	11
5.3. Suction cup with adapter	12
6. How to change the number of cups	14
6.1 Change to 1 cup	14
6.2 Change to 2 cups	15
7. Maintenance.....	16
7.1. Maintenance for suction cups with flange	16
7.2. Maintenance for suction cup	16
8. Precautions	17
8.1 Air supply	17
8.2 Suction cups with flange precautions	18
8.3 Suction cup precautions	19
9. Troubleshooting.....	23



Safety Instructions

These safety instructions are intended to prevent hazardous situations and/or equipment damage. These instructions indicate the level of potential hazard with the labels of “Caution,” “Warning” or “Danger.” They are all important notes for safety and must be followed in addition to International Standards (ISO/IEC)*1), and other safety regulations.

*1) ISO 4414: Pneumatic fluid power -- General rules relating to systems.

ISO 4413: Hydraulic fluid power -- General rules relating to systems.

IEC 60204-1: Safety of machinery -- Electrical equipment of machines .(Part 1: General requirements)

ISO 10218: Manipulating industrial robots -Safety.

etc.



Caution

Caution indicates a hazard with a low level of risk which, if not avoided, could result in minor or moderate injury.



Warning

Warning indicates a hazard with a medium level of risk which, if not avoided, could result in death or serious injury.



Danger

Danger indicates a hazard with a high level of risk which, if not avoided, will result in death or serious injury.

Warning

1. The compatibility of the product is the responsibility of the person who designs the equipment or decides its specifications.

Since the product specified here is used under various operating conditions, its compatibility with specific equipment must be decided by the person who designs the equipment or decides its specifications based on necessary analysis and test results.

The expected performance and safety assurance of the equipment will be the responsibility of the person who has determined its compatibility with the product.

This person should also continuously review all specifications of the product referring to its latest catalog information, with a view to giving due consideration to any possibility of equipment failure when configuring the equipment.

2. Only personnel with appropriate training should operate machinery and equipment.

The product specified here may become unsafe if handled incorrectly.

The assembly, operation and maintenance of machines or equipment including our products must be performed by an operator who is appropriately trained and experienced.

3. Do not service or attempt to remove product and machinery/equipment until safety is confirmed.

1. The inspection and maintenance of machinery/equipment should only be performed after measures to prevent falling or runaway of the driven objects have been confirmed.

2. When the product is to be removed, confirm that the safety measures as mentioned above are implemented and the power from any appropriate source is cut, and read and understand the specific product precautions of all relevant products carefully.

3. Before machinery/equipment is restarted, take measures to prevent unexpected operation and malfunction.

4. Contact SMC beforehand and take special consideration of safety measures if the product is to be used in any of the following conditions.

1. Conditions and environments outside of the given specifications, or use outdoors or in a place exposed to direct sunlight.

2. Installation on equipment in conjunction with atomic energy, railways, air navigation, space, shipping, vehicles, military, medical treatment, combustion and recreation, or equipment in contact with food and beverages, emergency stop circuits, clutch and brake circuits in press applications, safety equipment or other applications unsuitable for the standard specifications described in the product catalog.

3. An application which could have negative effects on people, property, or animals requiring special safety analysis.

4. Use in an interlock circuit, which requires the provision of double interlock for possible failure by using a mechanical protective function, and periodical checks to confirm proper operation.



Safety Instructions

Caution

The product is provided for use in manufacturing industries.

The product herein described is basically provided for peaceful use in manufacturing industries. If considering using the product in other industries, consult SMC beforehand and exchange specifications or a contract if necessary.
If anything is unclear, contact your nearest sales branch.

Limited warranty and Disclaimer/Compliance Requirements

The product used is subject to the following “Limited warranty and Disclaimer” and “Compliance Requirements”.

Read and accept them before using the product.

Limited warranty and Disclaimer

1. The warranty period of the product is 1 year in service or 1.5 years after the product is delivered, whichever is first.*2)

Also, the product may have specified durability, running distance or replacement parts. Please consult your nearest sales branch.

2. For any failure or damage reported within the warranty period which is clearly our responsibility, a replacement product or necessary parts will be provided.

This limited warranty applies only to our product independently, and not to any other damage incurred due to the failure of the product.

3. Prior to using SMC products, please read and understand the warranty terms and disclaimers noted in the specified catalog for the particular products.

***2) Suction cups are excluded from this 1 year warranty.**

A suction cup is a consumable part, so it is warranted for a year after it is delivered.

Also, even within the warranty period, the wear of a product due to the use of the suction cup or failure due to the deterioration of rubber material are not covered by the limited warranty.

Compliance Requirements

1. The use of SMC products with production equipment for the manufacture of weapons of mass destruction (WMD) or any other weapon is strictly prohibited.

2. The exports of SMC products or technology from one country to another are governed by the relevant security laws and regulation of the countries involved in the transaction. Prior to the shipment of a SMC product to another country, assure that all local rules governing that export are known and followed.

Caution

SMC products are not intended for use as instruments for legal metrology.

Measurement instruments that SMC manufactures or sells have not been qualified by type approval tests relevant to the metrology (measurement) laws of each country.

Therefore, SMC products cannot be used for business or certification ordained by the metrology (measurement) laws of each country.

1. Parts included in the package

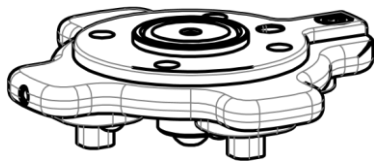

Cup mounting flange 1 pc.

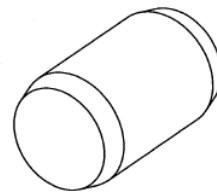

Parallel pin (6x10): 1 pc.

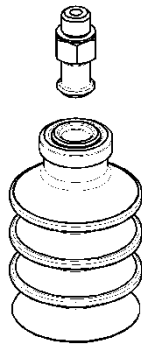

Suction cup with adapter: 4 pcs.

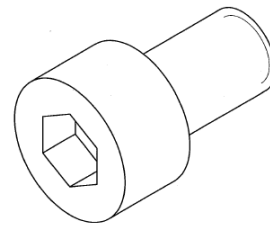

Hexagon socket head cap screw (M6x10): 4 pcs.



Plug: 1 pc.
Part No. M-5P
When Rc1/8 port use as vacuum pressure supply port.
(Mount to unused port.)



Plug: 4 pcs.
Part No. M-3P
Used for decreasing the number of suction cups.

2. Names of Parts of the Product

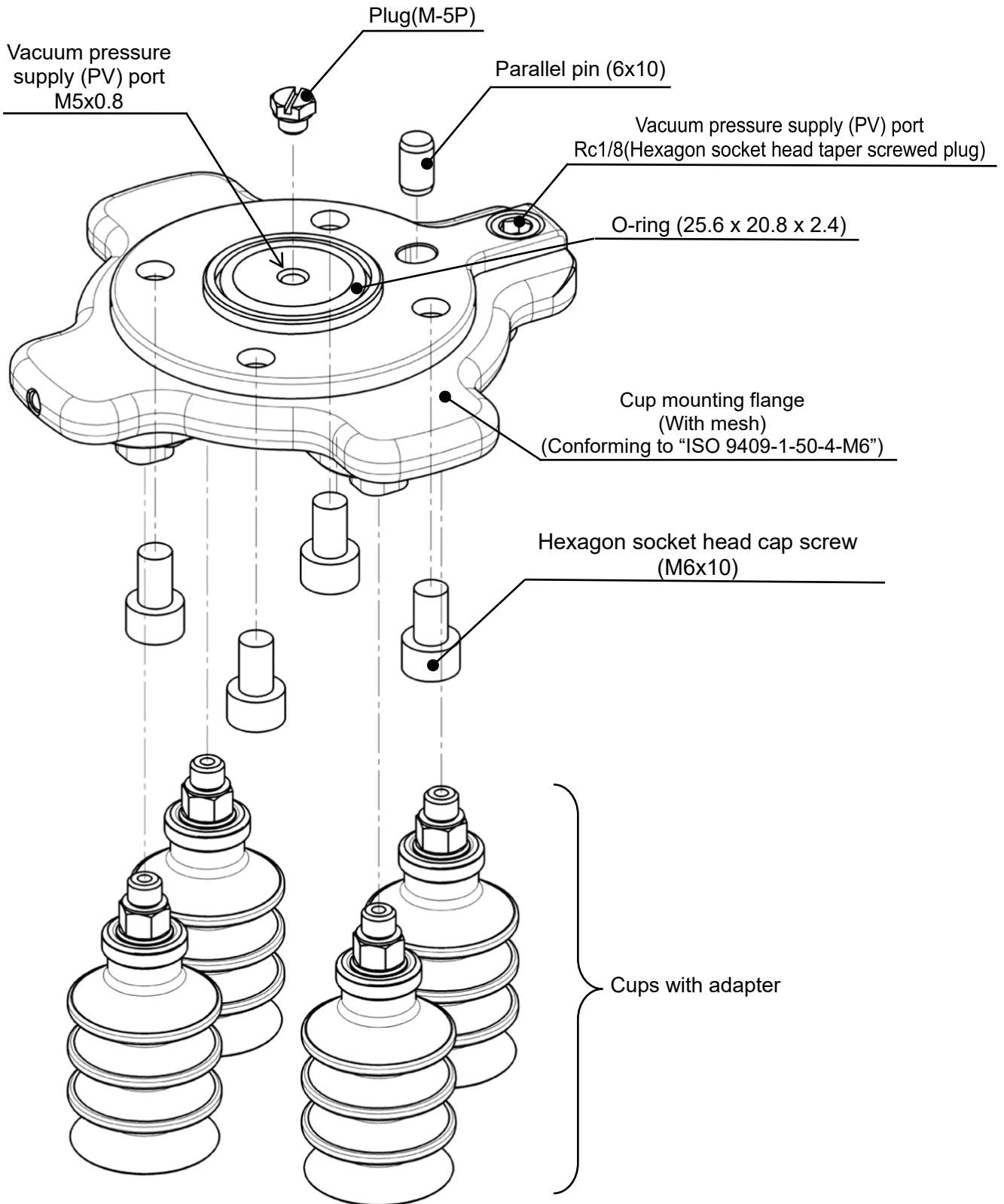

3. Specifications

3.1. Specifications

■ Product specifications

Standards	Conforming to "ISO 9409-1-50-4-M6"
Applicable fluid	Air
Operating temperature range [°C]	5 to 50
Weight [g] (Except cups with adapter)	228
Max. work load [kg] Note2)	7
Air pressure supply (P) port	M5x0.8, Rc1/8
Applicable suction cups	Refer to "3.3. How to order"

Note 1) The weight changes by the selected suction cup. Refer to "3.3 How to order".

Note 2) May be restricted depending on the cup diameter, mounting orientation, or workpiece. Please use within the max. work load. Suction and transfer exceeding the max. work load may result in reduced vacuum pressure due to air leakage.

3.2. How to calculate theoretical lifting force

*This manual shows how to calculate theoretical lifting force only. Refer to the catalog of suction cups for further detail of suction cup selection method.

■ How to calculate theoretical lifting force

The theoretical lifting force of a cup can be found by calculation or from the theoretical lifting force table.

Calculation

$$W = P \times S \times 0.1 \times \frac{1}{t}$$

W: Lifting force [N]

P: Vacuum pressure [kPa]

S: Cup area [cm²]

t: Safety factor Horizontal lifting: 4 or more

Vertical lifting: 8 or more

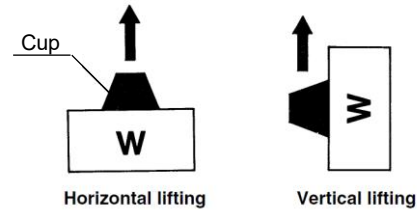

(This type of application should generally be avoided.)

Theoretical lifting force table

The theoretical lifting force (not including the safety factor) can be determined by the cup diameter and vacuum pressure.

The required lifting force can then be determined by dividing the theoretical lifting force by the safety factor t.

$$\text{Lifting force} = \text{Theoretical lifting force} / t$$

Theoretical lifting force (Theoretical lifting force = $P \times S \times 0.1$)

Cup diameter (Φ8 to Φ32)

Cup diameter [mm]		Φ8	Φ10	Φ13	Φ16	Φ20	Φ25	Φ32
S: Cup area [cm ²]		0.50	0.79	1.33	2.01	3.14	4.91	8.04
Vacuum pressure [kPa]	-85	4.2	6.6	11	17	26	41	68
	-80	4.0	6.2	10	16	25	39	64
	-75	3.7	5.8	10	15	23	36	60
	-70	3.5	5.5	9.3	14	22	34	56
	-65	3.2	5.1	8.6	13	20	31	52
	-60	3.0	4.7	8.0	12	18	29	48
	-55	2.7	4.3	7.3	11	17	27	44
	-50	2.5	3.9	6.7	10	15	24	40
	-45	2.2	3.5	6.0	9.0	14	22	36
-40	2.0	3.1	5.3	8.0	12	19	32	

3.3. How to order

■ Suction cups with flange

Suction cup part *1 Refer to the table below for the applicable cups.

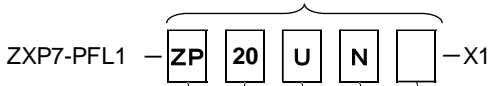

1) Cup series

Symbol	Cup Series
ZP	Basic
ZP3P	Bellows type for film packaging workpieces

2) Cup diameter

Symbol	Cup diameter
08	Φ8
10	Φ10
13	Φ13
16	Φ16
20	Φ20
25	Φ25
B25	Φ25
B30	Φ30
32	Φ32

3) Cup form

Symbol	Cup form
U	Flat
C	Flat with rib
B	Bellows
UT	Thin flat
J	Multistage bellows
JT2	2.5-stage bellows
JT5	5.5-stage bellows

4) Cup material

Symbol	Material
N	NBR
S	Silicone rubber (White) *1
U	Urethane rubber
F	FKM
SF	Silicone rubber (Blue) *1

*1 The silicone material is compliant with the FDA(U.S. Food and Drug Administration) regulation 21CFR § 177

5) Attachment *2

Symbol	Attachment
Nil	With (guide) attachment
M	With mesh attachment

*2 Only applicable to the cup form "JT□." Note that "M" applies only to cup form: JT2.

· See the table below for the suction cup part combination.

· Refer to the catalog of suction cup on the SMC website for the detail of suction cup.

*1

■ Suction Cup Part Numbers and Weight

ZXP7-PFL1 - (1) (2) (3) (4) (5) -X1

Applicable cups					Cup part numbers						
(1) Cup series	(2) Cup diameter	(3) Cup form	(4) Cup material	(5) Attachment	Cup with adapter				Adapter unit Vacuum inlet: Male thread M6x1	Cup unit	
					Part number	Weight by cup material (g/cup)					
						N (NBR)	S/SF (Silicone)	U (Urethane)	F (FKM)		
ZP	08	U	*		ZPT08U*-A6	4	4	4	4	ZPT1-A6	ZP08U*
ZP	08	B	*		ZPT08B*-A6	4	4	4	4		ZP08B*
ZP	10	UT	*		ZPT10UT*-A6	4	4	4	4	ZPT10U*	ZP10UT*
ZP	13	UT	*		ZPT13UT*-A6	4	4	4	4		ZP13UT*
ZP	16	UT	*		ZPT16UT*-A6	4	4	4	4	ZPT16U*	ZP16UT*
ZP	10	U	*		ZPT10U*-AS6	7	7	7	7		ZP10U*
ZP	13	U	*		ZPT13U*-AS6	7	7	7	8	ZPT2-AS6	ZP13U*
ZP	16	U	*		ZPT16U*-AS6	7	7	7	8		ZP16U*
ZP	20	U	*		ZPT20U*-AS6	9	10	10	10	ZPT3-AS6	ZP20U*
ZP	25	U	*		ZPT25U*-AS6	10	10	10	11		ZP25U*
ZP	32	U	*		ZPT32U*-AS6	10	11	11	12	ZPT2-AS6	ZP32U*
ZP	10	C	*		ZPT10C*-AS6	7	7	7	7		ZP10C*
ZP	13	C	*		ZPT13C*-AS6	7	7	7	7	ZPT16C*	ZP13C*
ZP	16	C	*		ZPT16C*-AS6	7	7	7	8		ZP16C*
ZP	20	C	*		ZPT20C*-AS6	9	10	10	11	ZPT3-AS6	ZP20C*
ZP	25	C	*		ZPT25C*-AS6	10	10	10	11		ZP25C*
ZP	32	C	*		ZPT32C*-AS6	10	11	11	12	ZPT2-AS6	ZP32C*
ZP	10	B	*		ZPT10B*-AS6	7	7	7	8		ZP10B*
ZP	13	B	*		ZPT13B*-AS6	7	8	8	8	ZPT3-AS6	ZP13B*
ZP	16	B	*		ZPT16B*-AS6	8	8	8	9		ZP16B*
ZP	20	B	*		ZPT20B*-AS6	11	11	11	13	ZPT2-AS6	ZP20B*
ZP	25	B	*		ZPT25B*-AS6	11	12	12	14		ZP25B*
ZP	32	B	*		ZPT32B*-AS6	14	15	15	18	ZPT3-AS6	ZP32B*
ZP	20	UT	*		ZPG20UT*-7A-X2	4	4	4	4		ZPT1-A6
ZP	16	J	*		ZPG16J*-7A-X2	8	8	8	9	ZPT2-AS6	ZP2-16J*
ZP	B25	J	*		ZPGB25J*-7A-X2	14	15	15	18	ZPT3-AS6	ZP2-B25J*
ZP	B30	J	*		ZPGB30J*-7A-X2	18	19	19	25		ZP2-B30J*
ZP3P	20	JT2	SF		ZP3PG20JT2SF-7A-X2	-	21	-	-	ZP3PA-T1JT-7A-X2	ZP3P-20JT2SF-W
ZP3P	20	JT2	SF	M	ZP3PG20JT2SF-M-7A-X2	-	21	-	-		ZP3P-20JT2SF-WM
ZP3P	32	JT2	SF		ZP3PG32JT2SF-7A-X2	-	48	-	-	ZP3PA-T2JT-7A-X2	ZP3P-32JT2SF-W
ZP3P	32	JT2	SF	M	ZP3PG32JT2SF-M-7A-X2	-	48	-	-		ZP3P-32JT2SF-WM
ZP3P	20	JT5	SF		ZP3PG20JT5SF-7A-X2	-	23	-	-	ZP3PA-T1JT-7A-X2	ZP3P-20JT5SF-WG
ZP3P	25	JT5	SF		ZP3PG25JT5SF-7A-X2	-	25	-	-		ZP3P-25JT5SF-WG
ZP3P	32	JT5	SF		ZP3PG32JT5SF-7A-X2	-	54	-	-	ZP3PA-T2JT-7A-X2	ZP3P-32JT5SF-WG

Input the material symbol ("N," "S," "U," or "F") into the * in the part number.

4. Mounting

4.1. Mounting

■ Mounting procedure

- 1) Confirm the gasket seal on the adapter, then mount 4 cups with adapter to the cup mounting flange.
(Tightening torque: $1\text{N} \cdot \text{m}$ or tighten for 45 degrees using a spanner after tightening by hand)
 - 2) Mount parallel pin to the robot tool flange pin hole.
 - 3) Align the parallel pin of the robot tool flange with the robot mounting flange, and assemble them with bolts included in the accessories. (Tightening torque: $5.2\pm 0.5\text{Nm}$)
- Removal should be performed by following the mounting procedure in reverse.

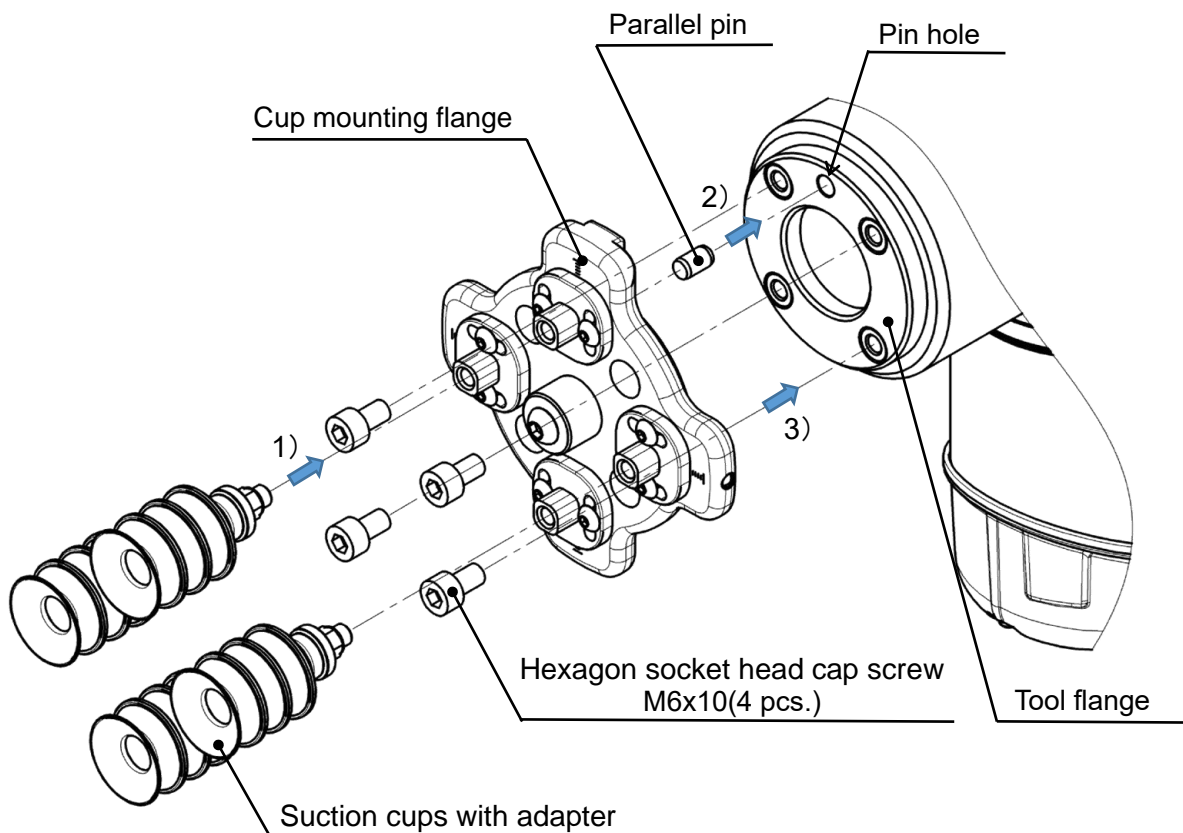
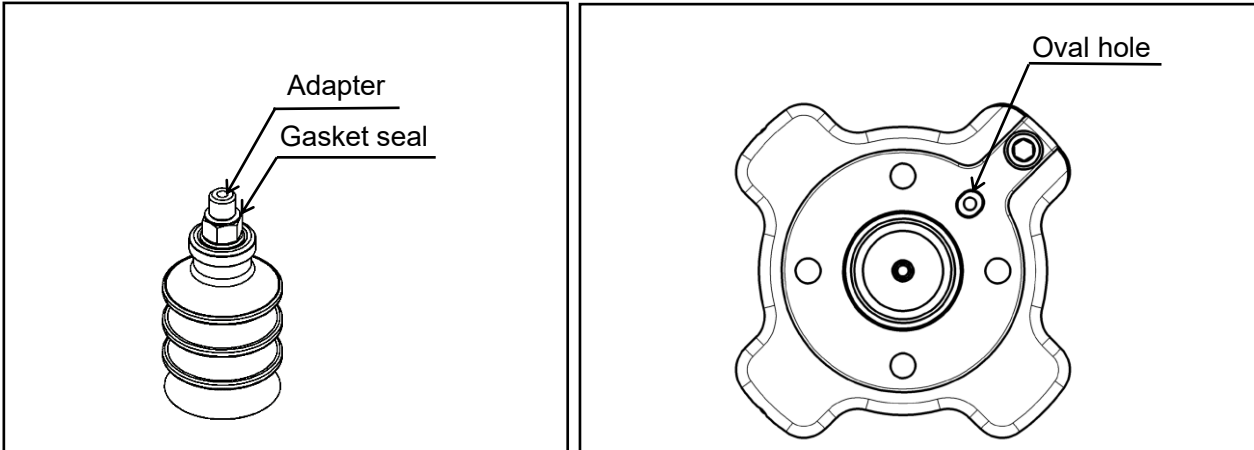

4.3. Piping

■ Tubing

If Rc1/8 port use as vacuum pressure supply port, please mount the plug (part number: M-5P) to M5x0.8 vacuum pressure supply (PV) port.

Please order one-touch fitting and tube separately for mounting to Rc1/8 port.

(Recommended one-touch fitting: KQ2L08-01NS, recommended tube: TU0805)

Connect a tube to the vacuum pressure supply (PV) port.

(Refer to the P.18 “ 2) Tube attachment ”)

To remove the tube, push the release button and pull out the tube.

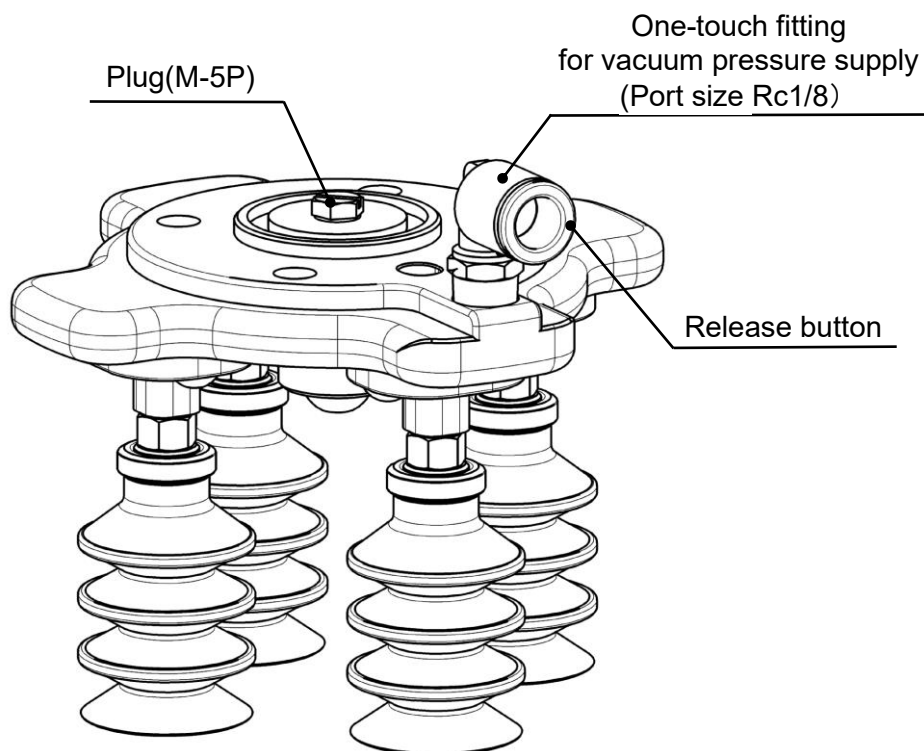

5. Dimensions

5.1. Suction cups with flange

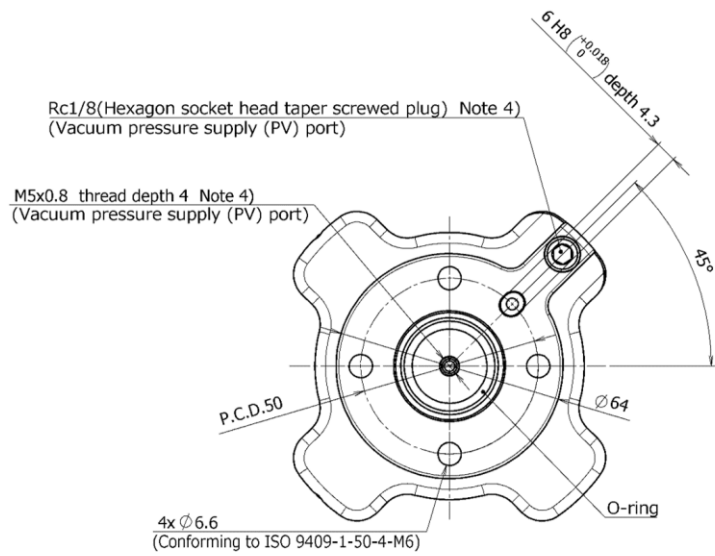

B (2 : 1)
When mounting plug(M-5P)

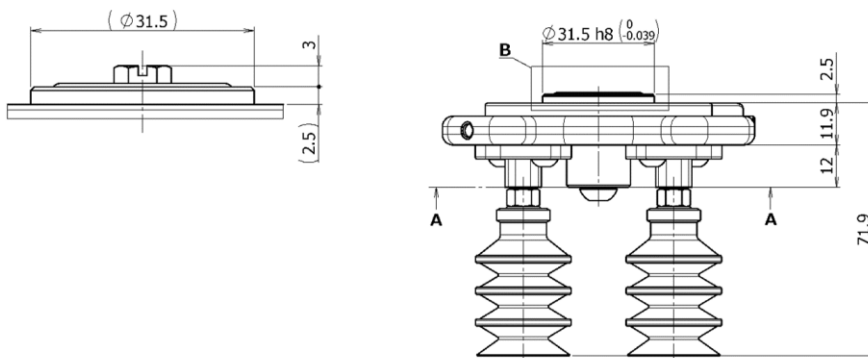

A-A
Mounting part of
suction cup with adapter

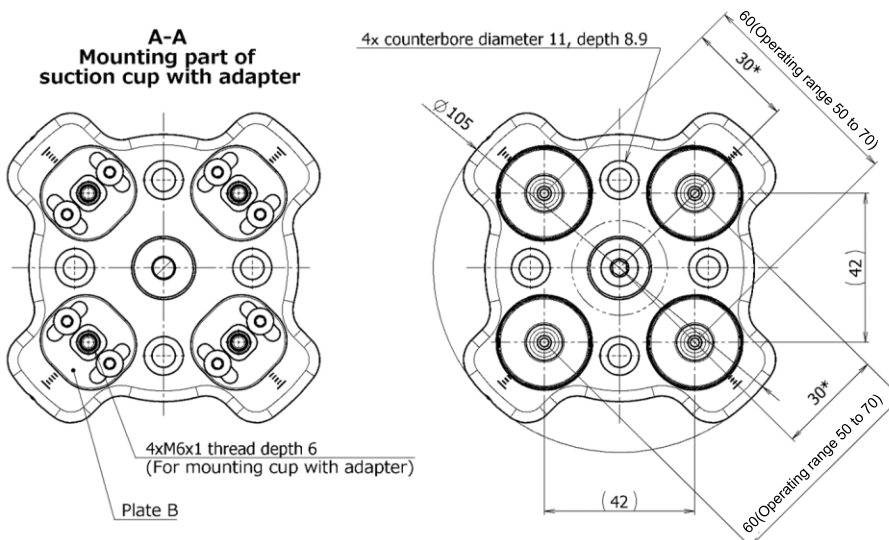

*Operating range: 25 to 35 (When a cup is mounted in the center)
As interference between cups may occur depending on the cup diameter, select the cup diameter according to the pitch to be used.
*Cup distance is changeable.

5.2. Center of gravity (ZXP7-PFL1-ZPB25JN-X1)

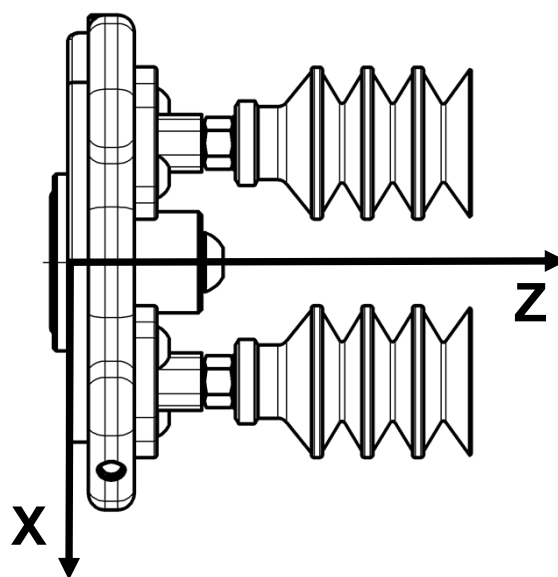
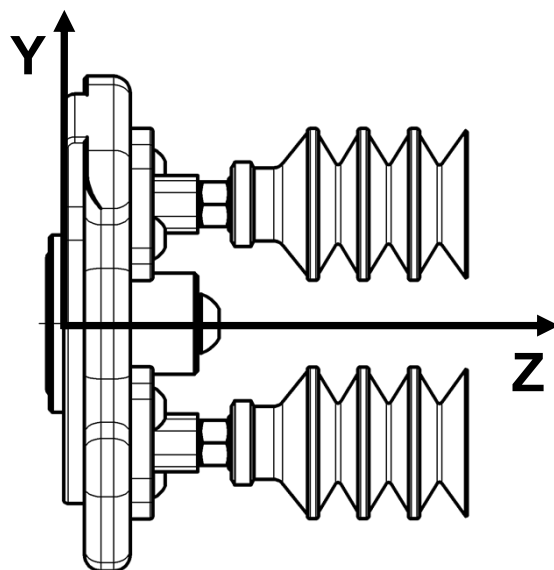
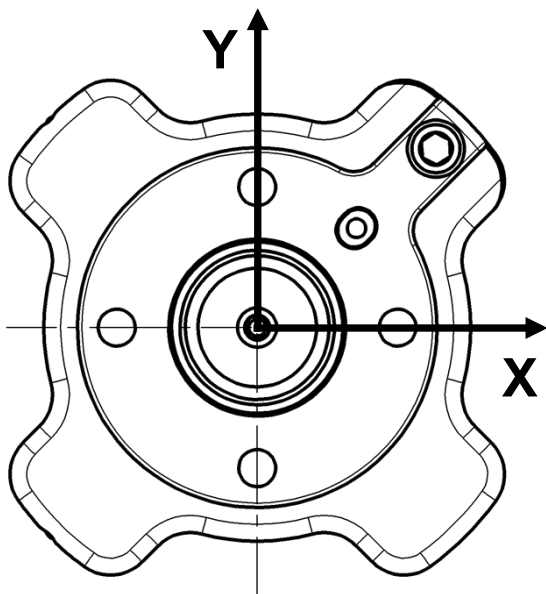

(Unit: mm)

Center of gravity		
X	Y	Z
0.64	0.57	13.96

5.3. Suction cup with adapter

*It is shown here for representative model only. See the suction cup catalog for the other models.

Model : ZPT*U*-AS6
(Suction cup form : Flat type)

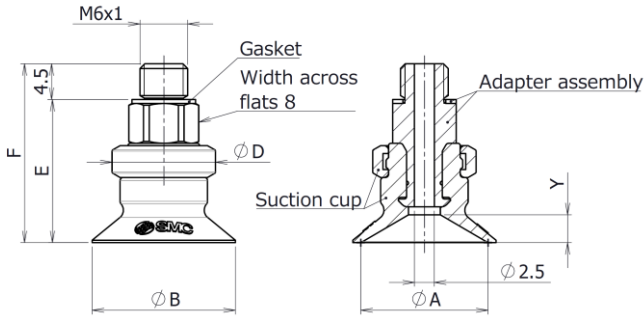

Dimensions

Model	A	B	D	E	F	Y
ZPT10U*-AS6	10	12	13	17.5	22	3
ZPT13U*-AS6	13	15		18	22.5	3.5
ZPT16U*-AS6	16	18		19.5	24	4
ZPT20U*-AS6	20	23	15	19.5	24	4
ZPT25U*-AS6	25	28		20	24.5	4.5
ZPT32U*-AS6	32	35				

Model : ZPT*C*-AS6
(Suction cup form : Flat type with ribs)

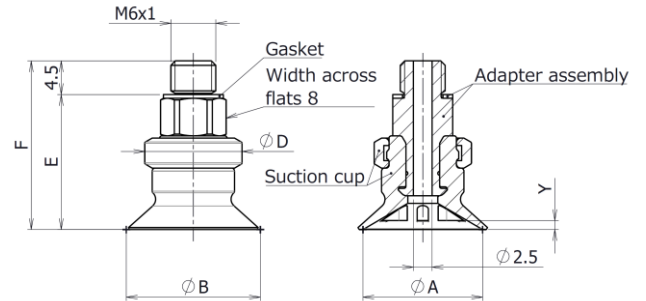

Dimensions

Model	A	B	D	E	F	Y
ZPT10C*-AS6	10	12	13	17.5	22	1.7
ZPT13C*-AS6	13	15				1.8
ZPT16C*-AS6	16	18				1.2
ZPT20C*-AS6	20	23	15	19.5	24	1.7
ZPT25C*-AS6	25	28				1.8
ZPT32C*-AS6	32	35				2.3

Model : ZPT*B*-AS6
(Suction cup form : Bellows type)

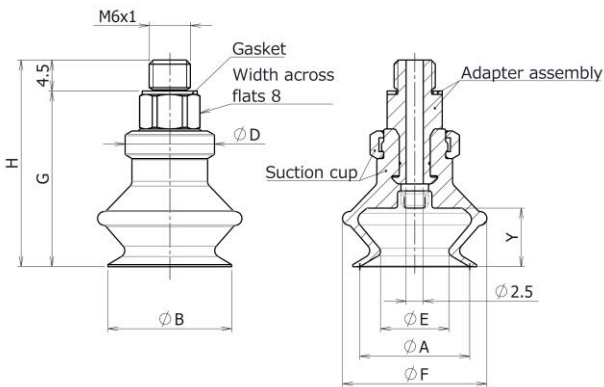

Dimensions

Model	A	B	D	E	F	G	H	Y
ZPT10B*-AS6	10	12	13	5.5	13.5	21.5	26	5.5
ZPT13B*-AS6	13	15		8.7	19	24	28.5	7.5
ZPT16B*-AS6	16	18		10	21	25.5	30	8.5
ZPT20B*-AS6	20	22	15	12.6	25	29	33.5	10.5
ZPT25B*-AS6	25	27		16	28	29.5	34	
ZPT32B*-AS6	32	34		18.9	37	34.5	39	14

Model : ZPG20UT*-7A-X2
(Suction cup form : Thin flat type)

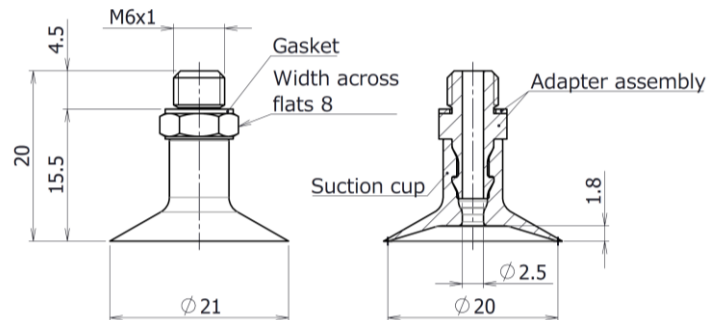

Model : ZPG16J*-7A-X2
 (Suction cup form : Multistage bellows type 2.5-Stage)

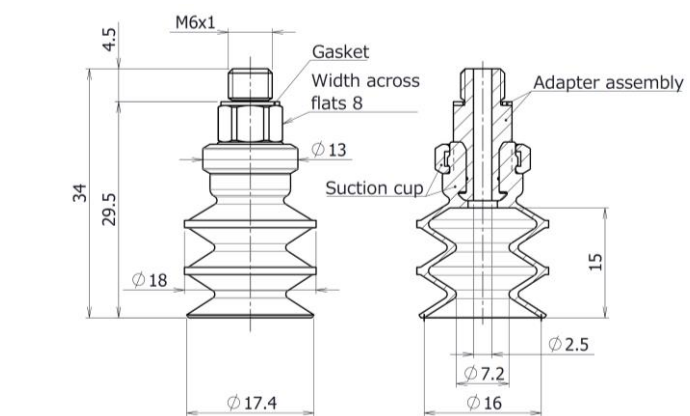

Model : ZPG(B25,B30)J*-7A-X2
 (Suction cup form : Multistage bellows type 3.5-Stage)

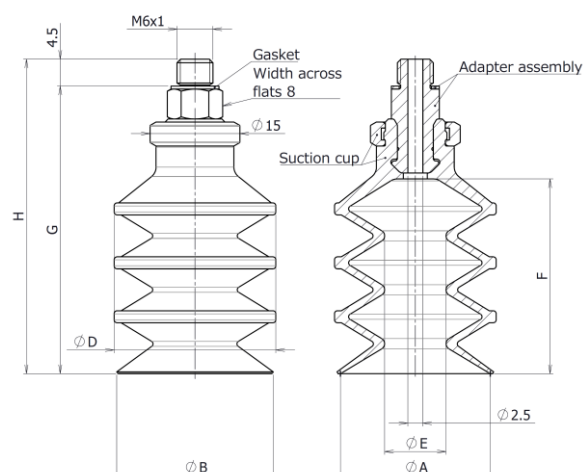

Dimensions

Model	A	B	D	E	F	G	H
ZPGB25J*-7A-X2	25	26	27	10.2	32.5	48	52.5
ZPGB30J*-7A-X2	30	33	32	13.8	38	54.5	59

Model : ZP3PG(20,25)JT5SF-7A-X2

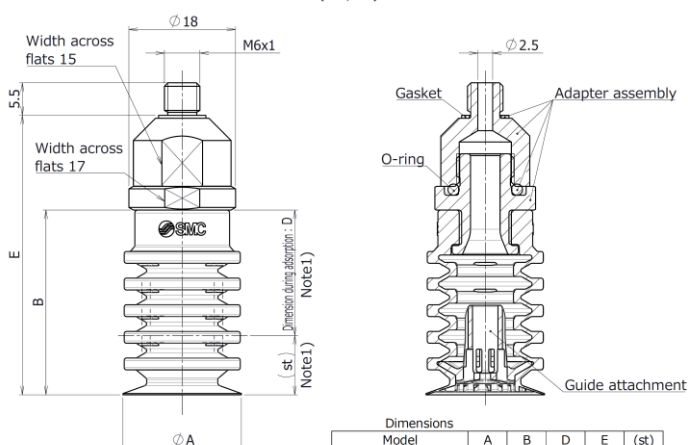

Model	A	B	D	E	(st)
ZP3PG20JT5SF-7A-X2	20	31.2	21.2	47.2	10
ZP3PG25JT5SF-7A-X2	25	35	23	51	12

Model : ZP3PG32JT5SF-7A-X2

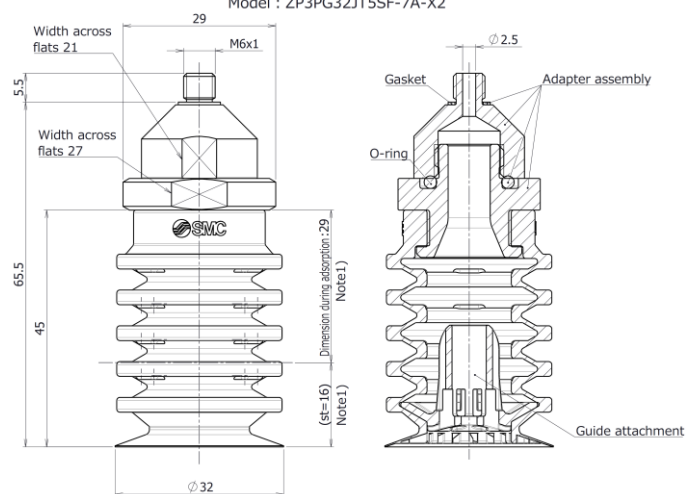

Note1) "D" and (st) indicate the reference value during gripping at vacuum pressure: -85[kPa].

6. How to change the number of cups

6.1 Change to 1 cup

1. Removal of the cup.

- (1) Remove the suction cup with adapter from plate B using a spanner.
- (2) Loosen the bolt (M4x8), then remove plate B from plate A.
Be careful not to lose the O-ring.
- (3) Loosen the bolt for sealing (M6x8), then remove the cup from plate A.

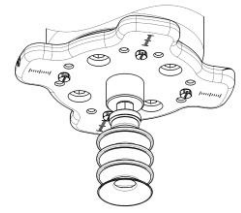

Completion drawing

2. Mounting of the plug and suction cup with adapter

- (1) Confirm the gasket seal in the accessory plug, then mount the plugs to plate A.
(4 places)
- (2) Confirm the gasket seal in the adapter, then mount the suction cup with adapter removed in the process (1) to plate A.

Reassemble the parts by reversing the disassembling process with specified tightening torque.

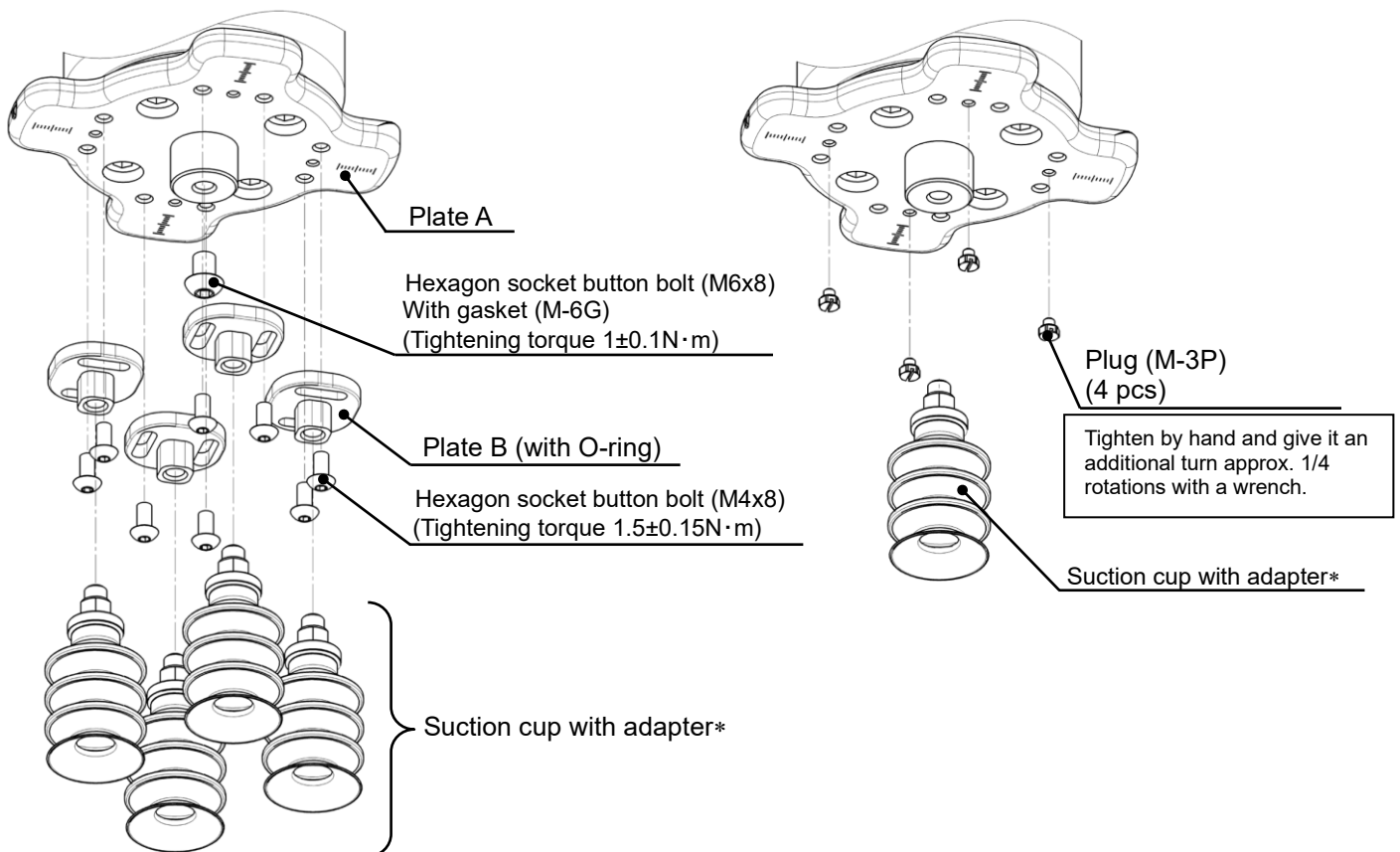

(1) Disassemble the suction cups with adapter

(2) Mounting plugs and a suction cup with adapter

Caution

- * Tightening torque: 1Nm, (As reference, tighten by 45 degrees using a spanner after tightening by hand.) If tightened excessively, thread portion may be damaged and gasket may be deformed. This will cause air leakage. Insufficient tightening may loosen the thread or cause air leakage.

6.2 Change to 2 cups

1. Removal of the cup

- (1) Remove the suction cup with adapter from the plate B using a spanner.
- (2) Loosen the bolt (M4x8), then remove plate B from plate A.
Be careful not to lose the O-ring.

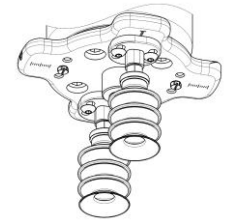

Completion drawing

2. Mounting of the plug

- Confirm the gasket seal in the plug, then mount the plugs to plate A.
Reassemble the parts by reversing the disassembling process with specified tightening torque.

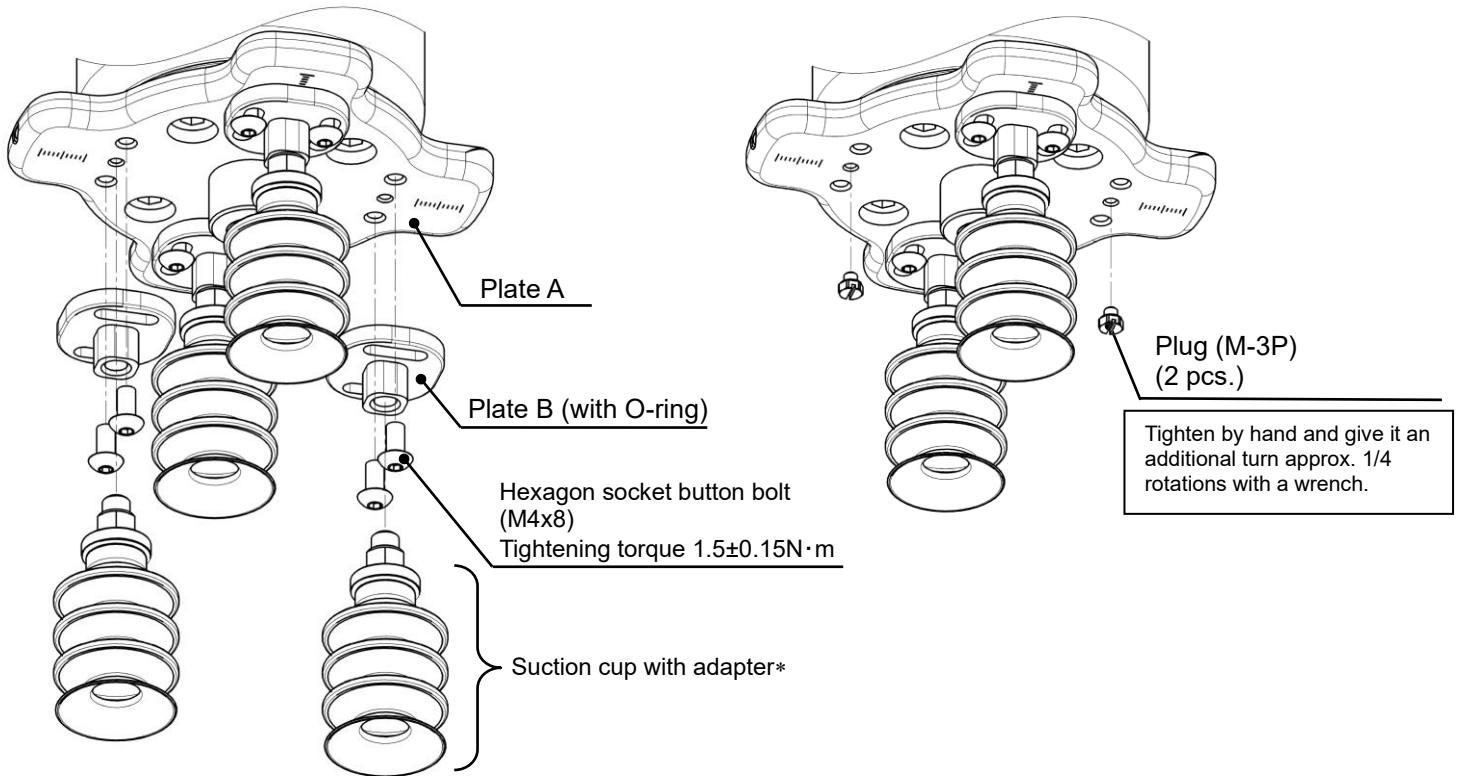

(1) Disassemble the suction cups with adapter

(2) Plug mounting

Caution

- * Tightening torque: $1\text{N} \cdot \text{m}$, (As reference, tighten by 45 degrees using a spanner after tightening by hand)
If tightened excessively, thread portion may be damaged and gasket may be deformed. This will cause air leakage. Insufficient tightening may loosen the thread or cause air leakage.

7. Maintenance

- Implement the maintenance and check shown below in order to use the vacuum gripper safely and in an appropriate way for a long period of time.

7.1. Maintenance for suction cups with flange

Caution

1) Check before and after the maintenance work

When the product is to be removed, turn off the power supply, and be sure to cut off the supply pressure and exhaust the compressed air. Confirm that the air is released to atmosphere.

When mounting the product after the maintenance work, supply compressed air, connect to the power, check if it functions properly and have a leakage inspection.

2) Maintenance should be performed according to the procedure indicated in the Operation Manual.

Improper handling can cause damage and malfunction of equipment and machinery.

3) Maintenance work

Compressed air can be dangerous when handled incorrectly. Therefore, in addition to observing the product specifications, replacement of elements and other maintenance activities should be performed by personnel with sufficient knowledge and experience pertaining to pneumatic equipment.

4) Draining

Remove condensate from air filters and mist separators regularly. If the collected drainage is drained to the downstream side, it can stick inside of the product, causing operation failure and failure to reach the specified vacuum pressure.

5) Do not disassemble or modify the product, other than the replacement parts specified in this manual.

7.2. Maintenance for suction cup

Caution

1) Suction cups are disposable. Replace them on a regular basis.

Continued use of suction cups will cause wear and tear on the gripping surface, and the exterior dimensions will gradually get smaller and smaller. As the cups' diameter gets smaller, their lifting force will decrease, though gripping will still remain possible.

It is extremely difficult to provide advice on the frequency of suction cup replacement. This is because there are numerous factors at work, including surface roughness, operating environment (temperature, humidity, ozone, solvents, etc.), and operating conditions (vacuum pressure, workpiece weight, pressing force of the suction cups on the workpieces, presence or absence of a buffer, etc.).

(The weakening of bent parts or the wear or sticking of rubber parts may occur with the bellows type cup.)

Thus, the customer should decide when suction cups should be replaced, based on their condition at the time of initial use.

The bolts may become loose depending on the operating conditions and environment. Be sure to perform regular maintenance.

<How to replace the suction cup>

- Pull the lock ring upward, and, after lifting it up to the adapter, remove the old cup by pulling it downward.
 - While holding the lock ring in the raised position place a new cup onto the adapter.
 - Confirm that the cup is securely in place, and then return the lock ring to its original position.
- * The cup without lock ring is just inserted to the end of the adapter.

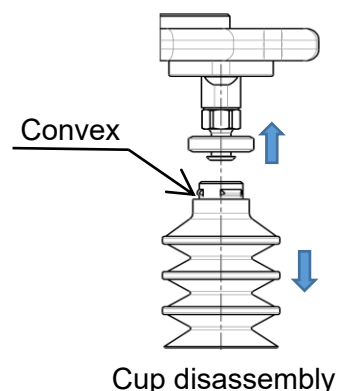
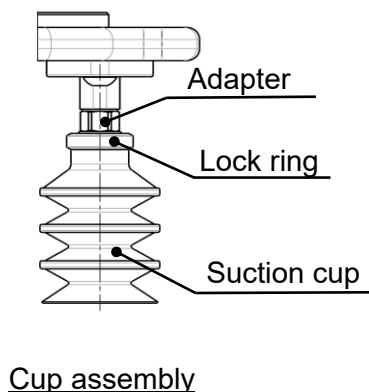

2) Mesh

If it is used in such a way that foreign matter is absorbed from the air or the workpiece, the mesh may become clogged. If the mesh is clogged, it will cause a reduction in the ejector performance. Clean the mesh periodically as necessary by washing, air blow and so on. If mesh clogging cannot be improved by cleaning, replace plate B.

•Part number for plate B for replacement : ZXP7-APL1-A-X1

Refer to "6.1 Change to one cup" for the replacement method.

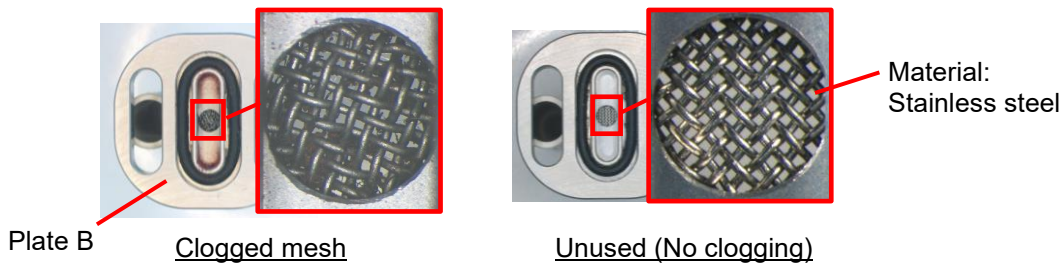

8. Precautions

8.1 Air supply

⚠ Warning

■ Use clean air.

Supply air containing foreign matter, water, oil, condensate, etc., can cause malfunction of the supply valve and release valve. So, install air preparation equipment on the upstream side of the product (refer to the piping example below) and perform maintenance periodically to control the supply air properly.

Refer to "SMC Air Preparation System" for further details on compressed air quality.

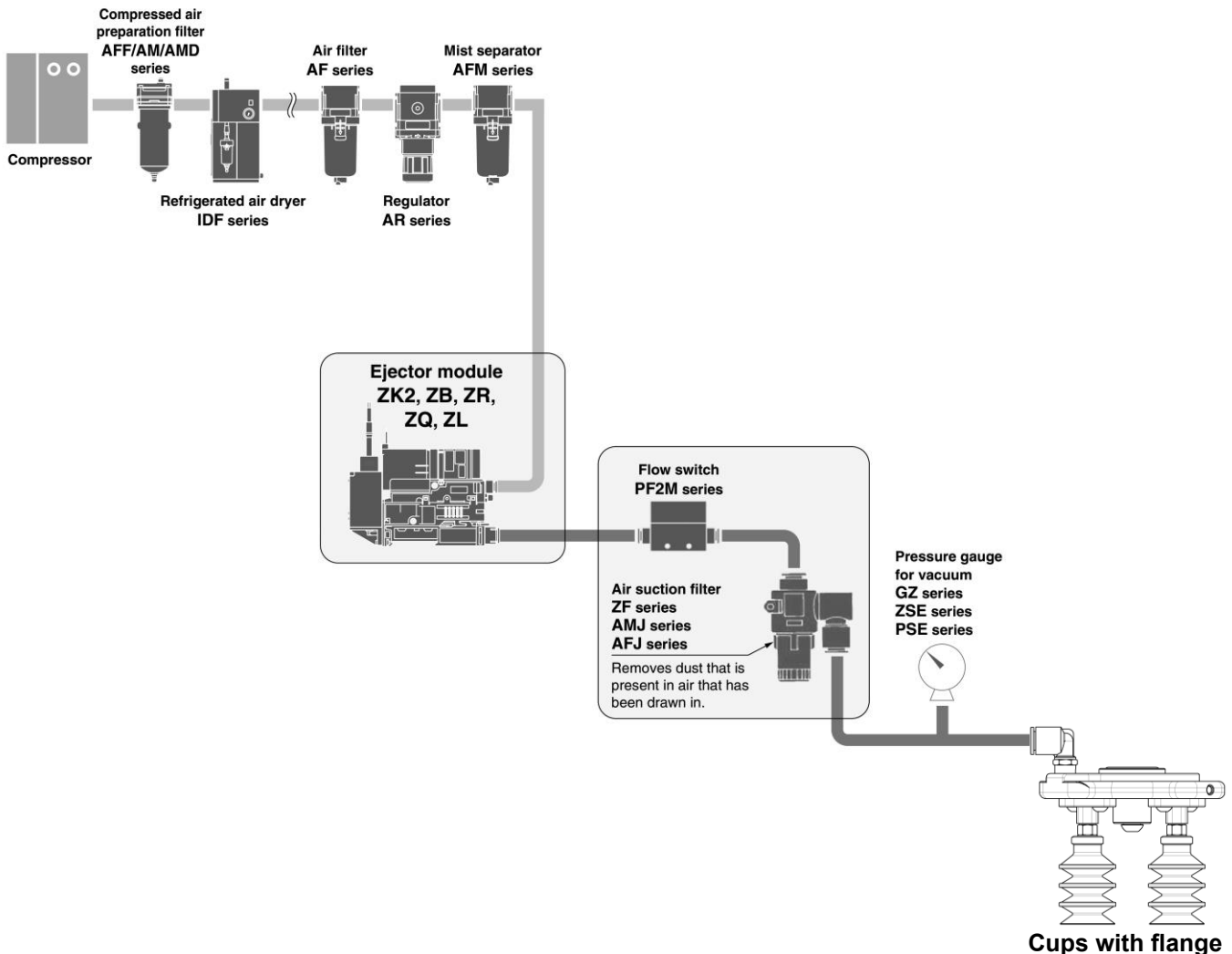

8.2 Suction cups with flange precautions

■ Designing



Warning

If power or air supply is shutdown, vacuum pressure may decrease and this product may drop a workpiece during gripping.

Please perform of safety measures by customer systems.

■ Mounting



Warning

1) Tighten to the specified tightening torque.

If the tightening torque is exceeded, the body and the mounting screws may break. However, insufficient torque may cause displacement of the body and loosening of the mounting screws.

2) Hold the product itself when handling.

It can cause the malfunction of the product.

■ Piping



Caution

1) Flushing of the inside of the pipes

Before piping is connected, it should be thoroughly blown out with air (flushing) or washed to remove chips, cutting oil, and other debris from inside the pipe.

2) Tube attachment

- Take a tube having no flaws on its periphery and cut it off at a right angle. When cutting the tube, use tube cutters TK-1,2,3,5, or 6. Do not use pliers, nippers, scissors, etc. If cutting is done with tools other than tube cutters, the tube may be cut diagonally or become flattened, etc., making a secure installation impossible, and causing problems such as the tube pulling out after installation or air leakage. Allow some extra length in the tube.

- Grasp the tube and push it in slowly, inserting it securely all the way into the fitting.

- After inserting the tube, pull on it lightly to confirm that it will not come out. If it is not installed securely all the way into the fitting, this can cause problems such as air leakage or the tube pulling out.

3) Tube detachment

- Push in the release button sufficiently, pushing its collar equally around the circumference.

- Pull out the tube while holding down the release button so that it does not come out. If the release button is not pressed down sufficiently, there will be increased bite on the tube and it will become more difficult to pull it out.

- When the removed tube is to be used again, cut off the portion which has been chewed before reusing it. If the chewed portion of the tube is used as is, this can cause trouble such as air leakage or difficulty in removing the tube.

4) Other Tube Brands

When using other than SMC brand tube, confirm that the following specifications are satisfied with respect to the tube outside diameter tolerance.

- Nylon tube Within ± 0.1 mm

- Soft nylon tube Within ± 0.1 mm

- Polyurethane tube Within +0.15mm, Within -0.2mm

Do not use tube which do not meet these outside diameter tolerances. It may not be possible to connect them, or they may cause other trouble, such as air leakage or the tube pulling out after connection.

5) Do not apply unnecessary forces, such as twisting, pulling moment loads, vibration, impact, etc., on fittings or tubing.

6) Tubing, with the exception of coiled tubing, requires stationary installation. Do not use standard tubing (non-coiled) in applications where tubing is required to travel inside the flexible protection tube. Tubing that travels may sustain abrasion, extension, or severance due to tensile force. The removal of tubing from the fitting may also occur. Use caution prior to use in an application.

- Do not lift the product body with the tube after connecting the tube to the product. Otherwise, damage to the one-touch fittings may occur. For details, refer to the "Handling Precautions for SMC Products" on the SMC website: <https://www.smcworld.com>

7) **Adjust the length of air tube following by the movement of the robot arm to avoid adding tension the tube.**

When adding the tension of tube repeatedly, it may result in air leakage.

And the tube bending radius in the vicinity of the fitting should be at least the minimum bending radius of the tubing.

■ **Workpiece**

If water drops or dust are attached on the workpiece surface, they may go into the vacuum ejector and may cause the low vacuum performance. Also when workpieces are permeable, there is a case that sufficient lifting force cannot get. In such cases, it is necessary to perform a suction test to check the compatibility to your application before actual usage.

8.3 Suction cup precautions

■ **Design**

 **Warning**

1) **In cases where the workpieces are heavy or dangerous objects, etc., take measures to address a possible loss of gripping force (installation of a drop prevention guide, etc.).**

In the case of transportation by vacuum gripping using suction cups, the gripping force is lost when there is a drop in vacuum pressure. Furthermore, since vacuum pressure can also deteriorate due to the wear and cracking of cups, vacuum leakage from piping, etc., be certain to perform maintenance on vacuum equipment.

■ **Selection**

 **Caution**

1) **The cup materials which can be used differ depending upon the operating environment.**

An appropriate cup material should be selected. Furthermore, since suction cups are manufactured for use with industrial products, they should not come into direct contact with medicines, food products, etc.

2) **Depending upon the weight and shape of the workpieces, the diameter, quantity, and shape of cups suitable for use will vary.**

Refer to “3.2. How to calculate theoretical lifting force” for the theoretical lifting force. Also, the selectable cups will differ based upon conditions other than the above, such as the condition of the workpiece surface (presence or absence of oil or water), the workpiece material, and its gas permeability. Confirmation is necessary by actually performing vacuum gripping on the subject workpieces.

3) **Do not apply an impact or large force to a cup when gripping a workpiece.**

This will cause the deformation, cracking, and wear of the cup to be accelerated. The stiffening ribs, etc., should touch lightly, while staying within the cup skirt's deformation range. Positioning should be performed accurately, especially in the case of small-diameter cups.

4) **When transporting vertically, factors such as acceleration, wind pressure, and impact force must be considered in addition to the workpiece weight.**

Use caution particularly when lifting items such as glass plates and circuit boards because a large force will be applied by wind pressure. When a workpiece which is oriented vertically is transported horizontally, large forces are applied by acceleration when movement is started and stopped. Furthermore, in cases where the cup and workpiece can slip easily, accelerations and decelerations of horizontal movement should be kept to a minimum.

5) **When transporting flat shaped workpieces that have large surface areas using multiple cups, care must be taken in arranging the cups, so that the workpieces are evenly gripped.**

6) **Use caution since the workpiece could rotate during transfer.**

Use of more than one cup for each workpiece is recommended.

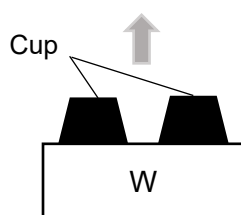

Horizontal lifting

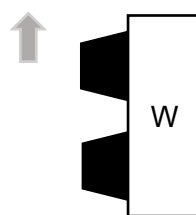

Vertical lifting

(This type of application should generally be avoided.)

■Gripping

This product has 4 pneumatically connected cups per ejector. If one cup fails to operate, all other cups cannot grip the object. Safety measures need to be taken to prevent falling of workpiece during transfer of the object. When gripping with cups which do not grip object is required, connect the vacuum saving valve, ZP2V series (Applicable model: ZP2V-B6-05). The valve suppresses the decrease of the vacuum pressure and there is a case that the workpiece can be held.

For the feasibility of workpiece and conditions of customer, operation check with the actual equipment is required.

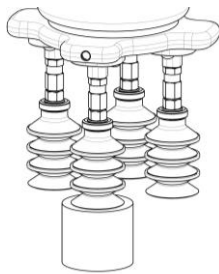
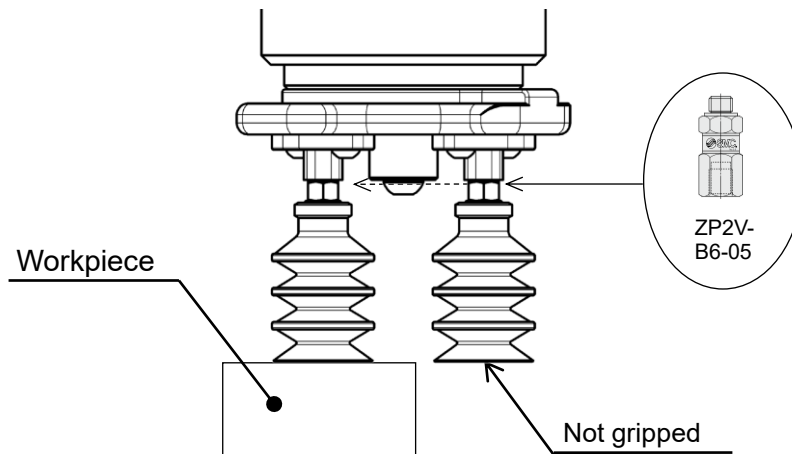

1 cup gripping

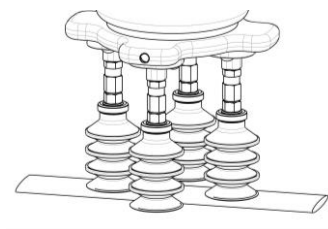

2 cups gripping

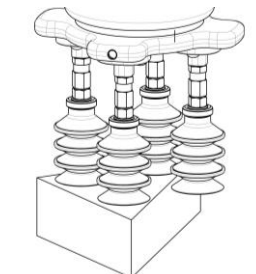

3 cups gripping

The following graph shows the performance when using vacuum gripper (ZXP7N) and ZP2V in combination with this product.

Refer to the ZXP series catalog for details of vacuum gripper.

If preparing a vacuum source separately, refer to ZP2V catalog “Model Selection” and evaluate with the actual condition.

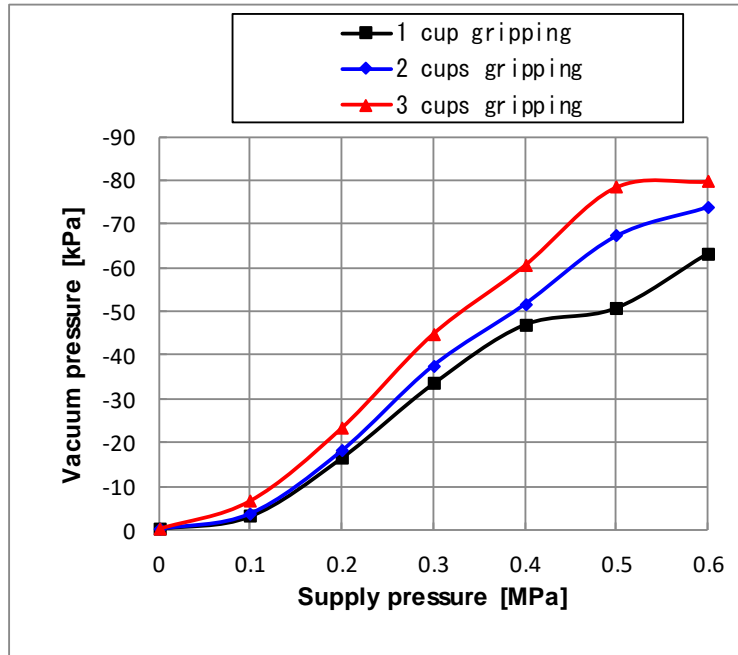

Exhaust Characteristics by using the vacuum saving valves: ZP2V-B06-05

* This data shows the data at the workpiece with no air leakage.

<Reference>

Theoretical lifting force of vacuum cup diameter 32mm with ZP2V-B06-05 at supply pressure 0.5 MPa

	Vacuum pressure [kPa]	Theoretical lifting force [N]	Horizontal lifting force [N] (Safety factor 1/4)
1 cup gripping	-50	40.2	10
2 cups gripping	-67	53.8	13.4
3 cups gripping	-73	58.7	14.6

(Calculated by “ $W = P \times S$, $S = \pi \cdot r^2$, $r = \Phi 32 / 2$ ”. Refer to 3.3 How to calculate theoretical lifting force for the detail.)

■ Maintenance

 **Caution**

1) **Perform pad maintenance regularly.**

Since pads are essentially rubber, deterioration is unavoidable. The rate of deterioration depends upon factors such as conditions of use, environment, and temperature. Regular maintenance should be performed. If any damage, splitting, cracking, or abrasion has occurred in a pad, replace it immediately. Also, take care not to damage the outside of the pad

■ Storage

 **Caution**

1) **It is recommended to store suction cups in the environment shown in the table below.**

Storing in an environment other than that recommended below may lead to changes in properties (deformation, discoloration, cracking, increased adhesiveness, etc.).

Recommended Storage Environment for Suction cups

Temperature	15 to 25[°C]
Humidity	50[%] or less, No condensation
Other	Location that is shaded from direct sunlight or fluorescent light Location without the presence of ozone (For NBR and conductive NBR)

9. Troubleshooting

Condition & Description of improvement	Contributing factor	Countermeasure
Initial gripping problem (During trial operation)	Gripping area is small. (Lifting force is lower than the workpiece mass.)	Recheck the relationship between workpiece mass and lifting force. - Use a suction cup with a large gripping area. - Increase the quantity of suction cups.
	Vacuum pressure is low. (Leakage from gripping surface) (Air permeable workpiece)	Eliminate (reduce) leakage from gripping surface. - Reconsider the shape of a suction cup. Check the relationship between suction flow rate and arrival pressure of vacuum ejector. - Increase gripping area.
	Inadequate supply pressure of vacuum ejector	Measure supply pressure in vacuum generation state. - Use standard supply pressure. - Reconsider compressed air circuit (line).
	Clogging of vacuum ejector (Infiltration of foreign matter during piping)	Follow the instruction of the ejector used about foreign matter removal.
	The pressure just before the supply (PV) port is low.	Depending on the piping volume (piping length and diameter), if the pressure just before the supply (PV) port falls below specified value, the performance such as vacuum pressure may reduce. - Raise the upstream pressure, and the pressure just before the supply (PV) port becomes specified value.
Late vacuum achieving time (Shortening of response time)	The set vacuum pressure for the suction verification is too high.	Set to suitable setting pressure.
Fluctuation in vacuum pressure	Fluctuation in supply pressure	Reconsider compressed air circuit (line). (Addition of a tank etc.)
	Vacuum pressure may fluctuate under certain conditions due to ejector characteristics.	Lower or raise supply pressure a little at a time, and use in a supply pressure range where vacuum pressure does not fluctuate.
Occurrence of abnormal noise (intermittent noise) from exhaust of vacuum ejector	Intermittent noise may occur under certain conditions due to ejector characteristics.	Lower or raise supply pressure a little at a time, and use in a supply pressure range where the intermittent noise does not occur.
Gripping problem over time (Gripping is normal during trial operation.)	Clogging of the silencer	Replace the silencer. Add a filter to supply (compressed) air circuit.
	Clogging of the mesh	Clean the mesh periodically as necessary by washing, air blow and so on or replacing plate B. Refer to "7.2 Maintenance for suction cup".
	Presence of foreign matter in the ejector.	Follow the instruction of the ejector used about foreign matter removal. Add a filter to supply (compressed) air circuit.
	Air leakage due to loosen the compressed vacuum pressure supply (PV) port	If the fitting of the vacuum pressure supply (PV) port is loose, tighten up it. Refer to the catalog of one-touch fittings about tightening torque.
	Cup (rubber) deterioration, cracking, etc.	Replace cups. Check the compatibility of vacuum cup material and workpiece.
Workpiece is not released.	The increase of stickiness due to the wearing of the cup (rubber).	Replace cups. Check the compatibility of the cup material and workpiece.
	Vacuum pressure is too high.	Set the vacuum pressure to the minimum value necessary.

Revision history
Rev. A: Applicable suction cup with adapter and adapter unit part number changed

SMC Corporation

4-14-1, Sotokanda, Chiyoda-ku, Tokyo 101-0021 JAPAN

Tel: + 81 3 5207 8249 Fax: +81 3 5298 5362

URL <https://www.smcworld.com>

Note: Specifications are subject to change without prior notice and any obligation on the part of the manufacturer.

© 2023 SMC Corporation All Rights Reserved



No. TQ1230001-OM107