



Operation Manual

PRODUCT NAME

Vacuum Gripper

MODEL / Series / Product Number

ZXP7*41-**-X1***

The outward appearance showed on this manual is an example of the vacuum gripper with suction cups which is indicated by the product number: ZXP7A41-ZPB25JS-X1. Refer to the suction cup catalog for the detail of other applicable suction cups.

SMC Corporation

Contents

Safety instructions.....	2
1. Parts included in the package.....	6
2. Names of Parts of the Product.....	7
3. Specifications.....	8
3.1. Specifications	8
3.2. Flow rate / Exhaust characteristics	9
3.3. How to calculate theoretical lifting force	10
3.4. How to order	11
4. Mounting.....	12
4.1. Mounting	12
4.2. Wiring	14
4.3. Piping	15
4.4. TMComponent	16
5. Dimensions.....	20
5.1. Vacuum Gripper	20
5.2. Center of gravity	21
5.3. Suction cup with adapter	22
6. How to change the number of cups.....	24
6.1 Change to 1 cup (with flange)	24
6.2 Change to 1 cup (without flange)	25
6.3 Change to 2 cups	26
7. Maintenance.....	27
7.1. Maintenance for vacuum gripper	27
7.2. Maintenance for suction cup	28
8. Precautions.....	29
8.1 Air supply	29
8.2 Vacuum gripper precautions	29
8.3 Suction cup precautions	32
9. Troubleshooting.....	35



Safety Instructions

These safety instructions are intended to prevent hazardous situations and/or equipment damage. These instructions indicate the level of potential hazard with the labels of “**Caution**,” “**Warning**” or “**Danger**.” They are all important notes for safety and must be followed in addition to International Standards (ISO/IEC)^{*)}, and other safety regulations.

*1) ISO 4414: Pneumatic fluid power - General rules and safety requirements for systems and their components
ISO 4413: Hydraulic fluid power - General rules and safety requirements for systems and their components
IEC 60204-1: Safety of machinery - Electrical equipment of machines - Part 1: General requirements
ISO 10218-1: Robots and robotic devices - Safety requirements for industrial robots - Part 1: Robots
etc.



Danger

Danger indicates a hazard with a high level of risk which, if not avoided, will result in death or serious injury.



Warning

Warning indicates a hazard with a medium level of risk which, if not avoided, could result in death or serious injury.



Caution

Caution indicates a hazard with a low level of risk which, if not avoided, could result in minor or moderate injury.



Warning

1. The compatibility of the product is the responsibility of the person who designs the equipment or decides its specifications.

Since the product specified here is used under various operating conditions, its compatibility with specific equipment must be decided by the person who designs the equipment or decides its specifications based on necessary analysis and test results. The expected performance and safety assurance of the equipment will be the responsibility of the person who has determined its compatibility with the product. This person should also continuously review all specifications of the product referring to its latest catalog information, with a view to giving due consideration to any possibility of equipment failure when configuring the equipment.

2. Only personnel with appropriate training should operate machinery and equipment.

The product specified here may become unsafe if handled incorrectly. The assembly, operation and maintenance of machines or equipment including our products must be performed by an operator who is appropriately trained and experienced.

3. Do not service or attempt to remove product and machinery/equipment until safety is confirmed.

1. The inspection and maintenance of machinery/equipment should only be performed after measures to prevent falling or runaway of the driven objects have been confirmed.
2. When the product is to be removed, confirm that the safety measures as mentioned above are implemented and the power from any appropriate source is cut, and read and understand the specific product precautions of all relevant products carefully.
3. Before machinery/equipment is restarted, take measures to prevent unexpected operation and malfunction.

4. Our products cannot be used beyond their specifications. Our products are not developed, designed, and manufactured to be used under the following conditions or environments.

Use under such conditions or environments is not covered.

1. Conditions and environments outside of the given specifications, or use outdoors or in a place exposed to direct sunlight.
2. Use for nuclear power, railways, aviation, space equipment, ships, vehicles, military application, equipment affecting human life, body, and property, fuel equipment, entertainment equipment, emergency shut-off circuits, press clutches, brake circuits, safety equipment, etc., and use for applications that do not conform to standard specifications such as catalogs and operation manuals.
3. Use for interlock circuits, except for use with double interlock such as installing a mechanical protection function in case of failure. Please periodically inspect the product to confirm that the product is operating properly.



Safety Instructions

Caution

We develop, design, and manufacture our products to be used for automatic control equipment, and provide them for peaceful use in manufacturing industries.

Use in non-manufacturing industries is not covered.

Products we manufacture and sell cannot be used for the purpose of transactions or certification specified in the Measurement Act.

The new Measurement Act prohibits use of any unit other than SI units in Japan.

Limited warranty and Disclaimer/Compliance Requirements

The product used is subject to the following “Limited warranty and Disclaimer” and “Compliance Requirements”. Read and accept them before using the product.

Limited warranty and Disclaimer

1. The warranty period of the product is 1 year in service or 1.5 years after the product is delivered, whichever is first.*2)

Also, the product may have specified durability, running distance or replacement parts. Please consult your nearest sales branch.

2. For any failure or damage reported within the warranty period which is clearly our responsibility, a replacement product or necessary parts will be provided.

This limited warranty applies only to our product independently, and not to any other damage incurred due to the failure of the product.

3. Prior to using SMC products, please read and understand the warranty terms and disclaimers noted in the specified catalog for the particular products.

***2) Vacuum pads are excluded from this 1 year warranty.**

A vacuum pad is a consumable part, so it is warranted for a year after it is delivered.



Also, even within the warranty period, the wear of a product due to the use of the vacuum pad or failure due to the deterioration of rubber material are not covered by the limited warranty

Compliance Requirements

1. The use of SMC products with production equipment for the manufacture of weapons of mass destruction (WMD) or any other weapon is strictly prohibited.

2. The exports of SMC products or technology from one country to another are governed by the relevant security laws and regulations of the countries involved in the transaction. Prior to the shipment of a SMC product to another country, assure that all local rules governing that export are known and followed.









■ Explanation of Symbols

Symbol	Definition
	Things you must not do. Instructions are provided as a drawing or sentence next to the symbol.
	Things you must do Instructions are provided as a drawing or sentence next to the symbol.



■ Operator

1. This Operation Manual is intended for those who have knowledge of machinery using pneumatic equipment, and have sufficient knowledge of assembly, operation and maintenance of such equipment.
Only those persons are allowed to perform assembly, operation and maintenance.
2. Read and understand this Operation Manual carefully before assembling, operating or providing maintenance to the product.

■ Safety Instructions

 Warning	
 Disassembly prohibited	Do not disassemble, modify (including the replacement of board) or repair other than instructed in this manual. Otherwise, an injury or failure can result.
 Do not	Do not operate the product outside of the specifications. Do not use for flammable or harmful fluids. Fire, malfunction, or damage to the product can result. Please check the specifications before use.
 Do not	Do not use in an atmosphere containing flammable or explosive gases. Fire or an explosion can result. The product is not designed to be explosion proof.
 Do not	Do not use the product in a place where static electricity is a problem. Otherwise failure or malfunction of the system can result.
 Do not	Do not cut off the power and compressed air supplied to this product while it is operating. Otherwise it can cause injury due to dropping of workpieces or damage to the system.
 Instruction	If using the product in an interlocking circuit <ul style="list-style-type: none"> - Provide a double interlocking system, for example a mechanical system. - Check the product for proper operation. Otherwise malfunction can result, causing an accident.
 Instruction	The following instructions must be followed during maintenance <ul style="list-style-type: none"> - Turn off the power supply - Stop the air supply, exhaust the residual pressure in piping and verify that the air is released before performing maintenance work. It may cause an injury.

⚠ Caution

 Do not touch	Do not touch the terminals and connectors while the power is on. Otherwise electric shock, malfunction or damage to the switch can result.
 Instruction	Perform sufficient trial run. Otherwise, injury or damage to the system can result due to suction failure depending on the conditions of the suction of the workpiece. Perform sufficient verification before using this product.
 Instruction	After maintenance is complete, perform appropriate functional inspections and leak test. Stop operation if the equipment does not function properly or there is leakage of fluid. If there is leakage from parts other than the piping, the product might be broken. Cut off the power supply and stop the fluid supply. Do not supply fluid if there is leakage. Safety cannot be assured in the case of an unexpected malfunction.

■ Precautions for Handling

Follow the instructions given below for selecting and handling of the vacuum gripper.

*Product specifications

- It is recommended to use compressed air which purity class is 2:6:3 of ISO8573-1:2010.
- The applicable fluid is air.
Do not use a fluid containing chemicals, synthetic oils including organic solvent, salt and corrosive gases.
Otherwise, damage to the vacuum gripper and malfunction can result.
- Use the specified operating pressure.
- Reserve a space for maintenance.
Design the system allowing the required space for maintenance.
- Use the specified voltage. Otherwise failure or malfunction can result.
- Do not exceed the specified maximum allowable load. Otherwise it can cause damage or shorten the life of the product.
- Design the product to prevent reverse current when the circuit is opened or the product is forced to operate for operational check. Reverse current can cause malfunction or damage the product.

*Operating environment

- Do not use in an environment where corrosive gases, chemicals, sea water, water or steam are present.
- Do not use the product in a place where the product could be splashed by oil or chemicals.
If the product is to be used in an environment containing oils or chemicals such as coolant or cleaning solvent, even for a short time, the solenoid valve or pressure switch/sensor may be adversely affected (damage, malfunction, or hardening of the lead wires).
- Do not use in an area where surges are generated.
When there are machines or equipment that generate large surge near the pressure switch/sensor (magnetic type lifter, high frequency inductive furnace, motor, etc.), this can result in deterioration and damage of the internal elements. Take measures against the surge sources, and prevent the lines from coming into close contact.
- Do not use a load which generates surge voltage.
When a surge-generating load such as a relay or solenoid is directly driven, use the product with a surge absorbing element built-in.
- Mount the product in a location that is not affected by vibration or impact.
It will cause failure or malfunction.
- Do not use the product in an environment that is exposed to temperature cycle.
Heat cycles other than ordinary changes in temperature can adversely affect the inside of the product.
- Do not expose the product to direct sunlight.
If using in a location directly exposed to sunlight, protect the product from the sunlight.
- Keep within the specified operating fluid and ambient temperature range.
Operation under low temperature may lead to damage or operation failure due to frozen moisture in the fluid or air.
Protection against freezing is necessary. Mounting of an air dryer is recommended for elimination of drainage and water.
Avoid abrupt temperature changes even within the specified temperature range.
- Do not use in a location where the product is exposed to radiant heat from surrounding heat sources.
Insufficient air quality may cause operation failure.

1. Parts included in the package

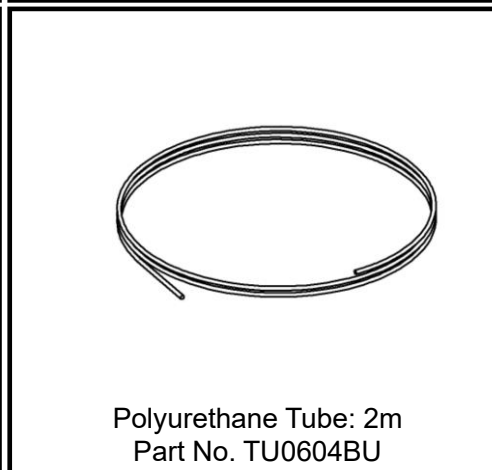
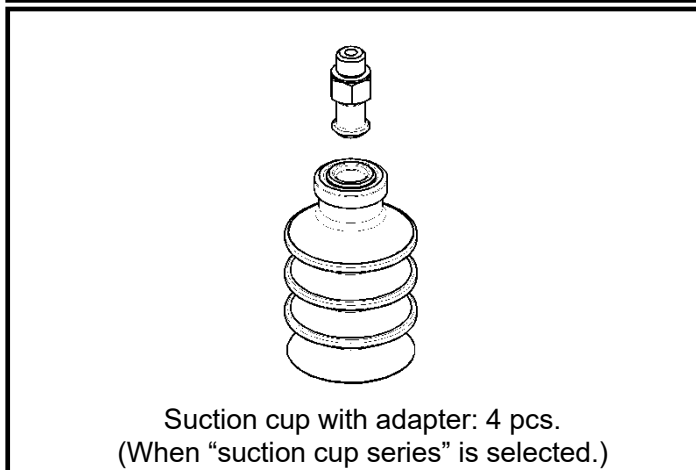
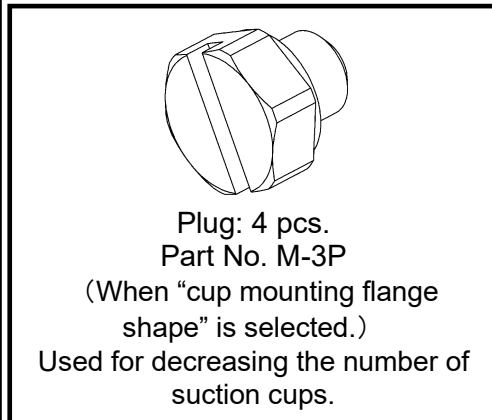
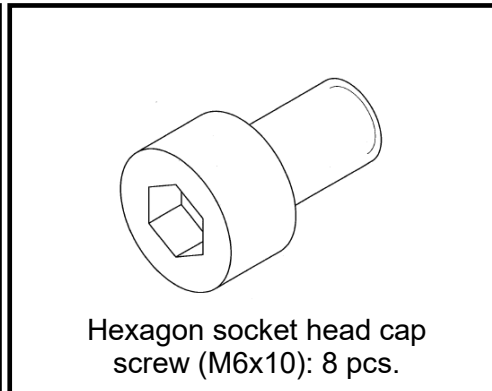
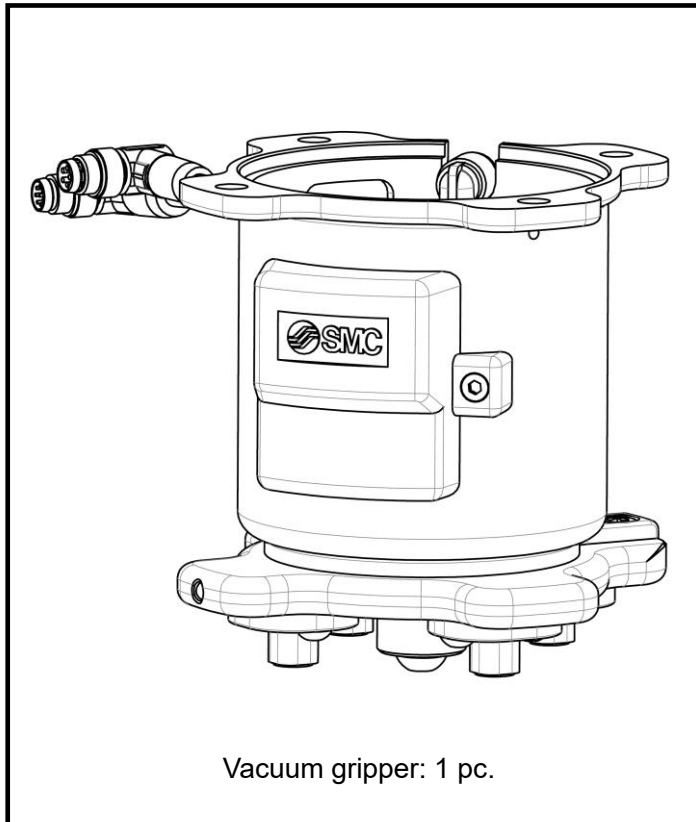
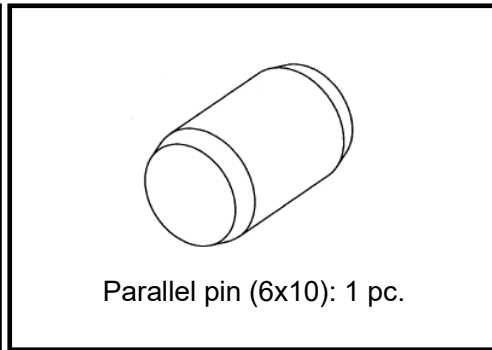
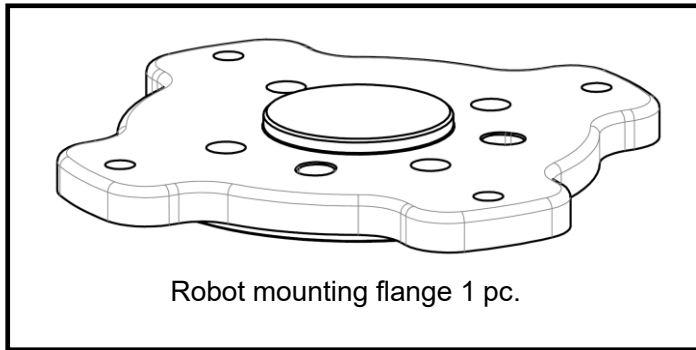

* Download the TMCComponent from the SMC website and then store it in your USB memory.

2. Names of Parts of the Product

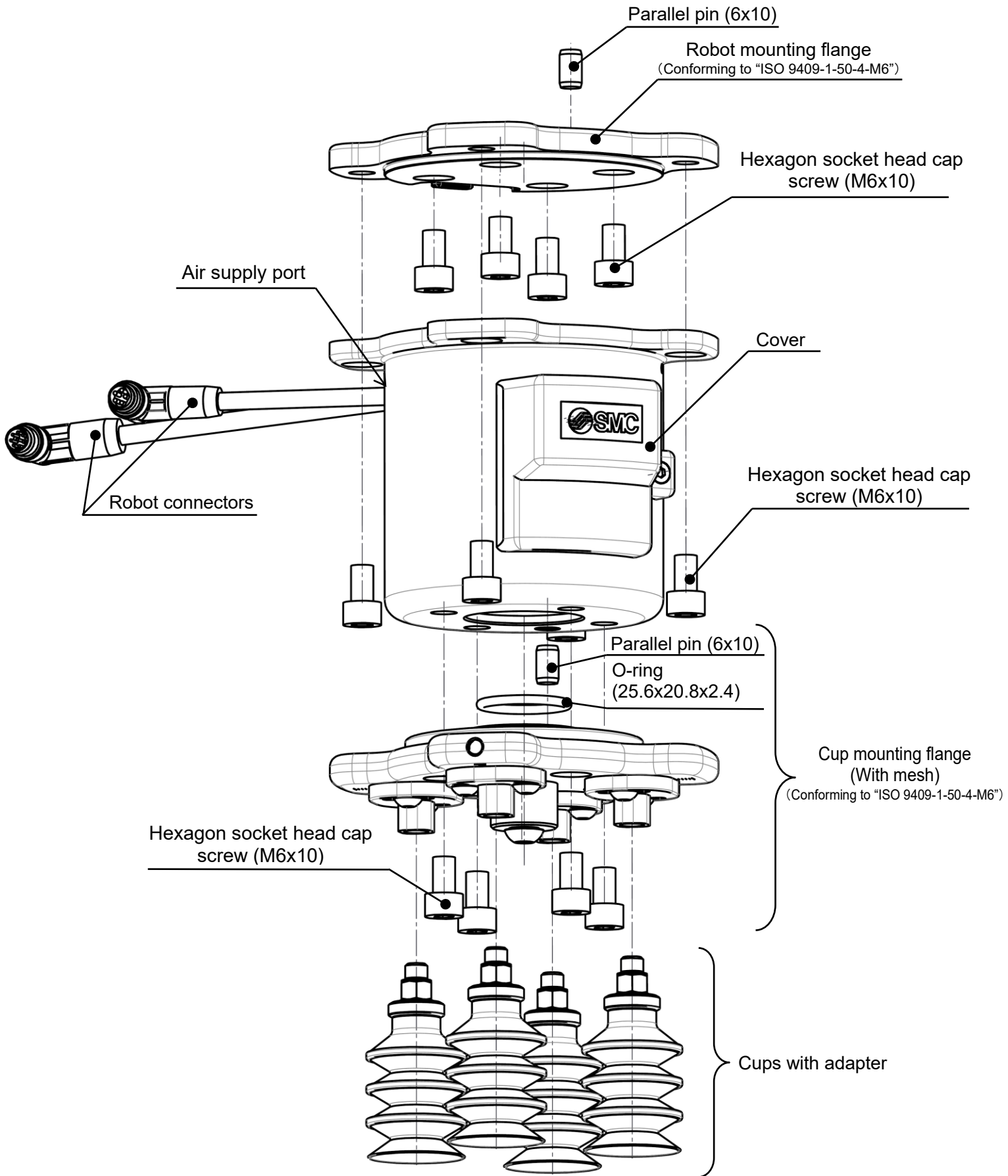

3. Specifications

3.1. Specifications

■ Product specifications

Common	Standards		Conforming to "ISO 9409-1-50-4-M6"
	Applicable fluid		Air
	Operating temperature range [°C]		5 to 50
	Connector type		M8 8-pin connector (Plug) M8 5-pin connector (Plug)
	Weight [g]	ZXP7N41-X1	597
		ZXP7A41-X1	810
		Example) ZXP7A41-ZPB25JS-X1	866 note1)
	Max. work load [kg] Note2)		7
	Impact / Vibration resistance [m/s ²] Note3)		150 / 30
	Air pressure supply (P) port		One-touch fitting (Φ6)
Power supply voltage [V]		24 VDC ±10%	
Vacuum ejector	Max. vacuum pressure [kPa] note4)		-84
	Suction flow rate [L/min(ANR)] note4)		17
	Air consumption [L/min(ANR)] note4)		57
	Supply pressure range [MPa]		0.3 to 0.55
	Standard supply pressure [MPa] note5)		0.5
Solenoid valve	Model		V114
Pressure sensor	Model		PSE541-R04
	Rated pressure range [kPa]		0 to -101
	Accuracy [%] (Ambient temperature at 25°C)		±2 F.S. (within rated pressure range)
	Linearity [%]		±0.4 F.S.
	Repeatability [%]		±0.2 F.S.
	Temperature characteristics [%]		±2 F.S. (25°C reference)
Applicable suction cups		Refer to "3.4. How to order"	
Standard		CE/UKCA MARKED	

Note 1) The weight changes by the selected suction cup. Refer to "3.4 How to order".

Note 2) May be restricted depending on the cup diameter, mounting orientation, or workpiece. Please use within the max. work load. Suction and transfer exceeding the max. work load may result in reduced vacuum pressure due to air leakage.

Note 3) Impact resistance: The characteristics are satisfied after tested one time in each of the X, Y and Z directions without energization. (Initial value)

Vibration resistance: The characteristics are satisfied after tested a one sweep in each of the X, Y and Z directions at 10 to 500 Hz without energization. (Initial value)

Note4) Values are at the standard supply pressure and based on SMC's measurement standards.

They depend on atmospheric pressure (weather, altitude, etc.) and the measurement method.

Note 5) This value indicates the pressure right before the air pressure supply pressure (P) port when vacuum is generated.

The pressure right before the P port of the vacuum gripper when vacuum is generated may fall below 0.5 MPa due to the air supply capacity, piping size, and the amount of air being consumed by other devices being operated simultaneously.

3.2. Flow rate / Exhaust characteristics

■ Flow rate / Exhaust characteristics.

The flow rate characteristics correspond to the standard supply pressure (0.5MPa).

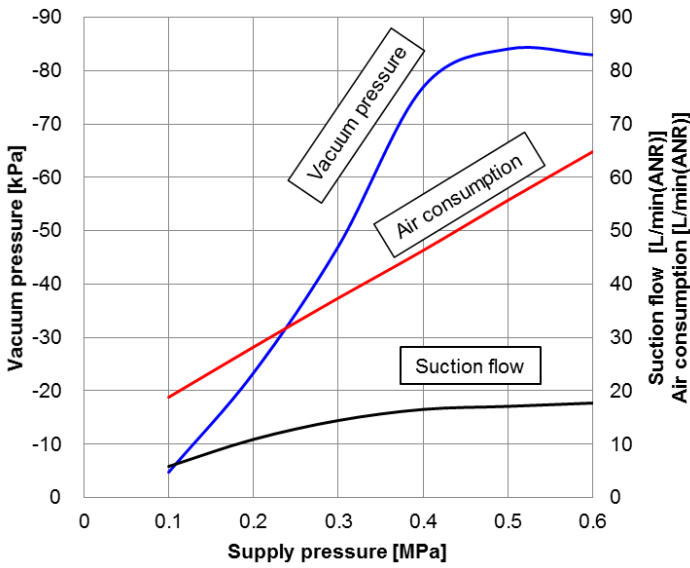

Exhaust characteristics

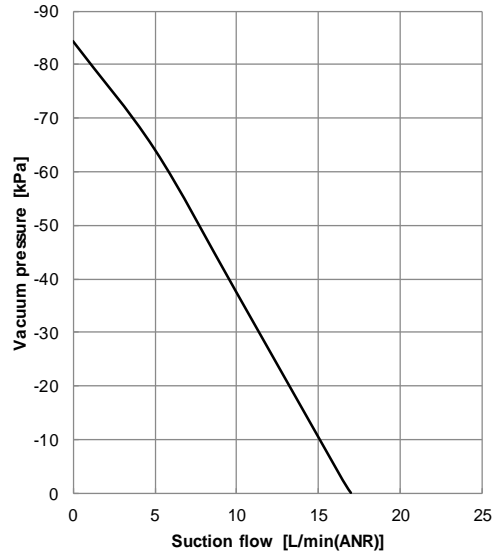

Flow rate characteristics

* The actual suction flow at the point of suction varies depending on the piping conditions to the vacuum port.

■ How to read the flow rate characteristics Graph

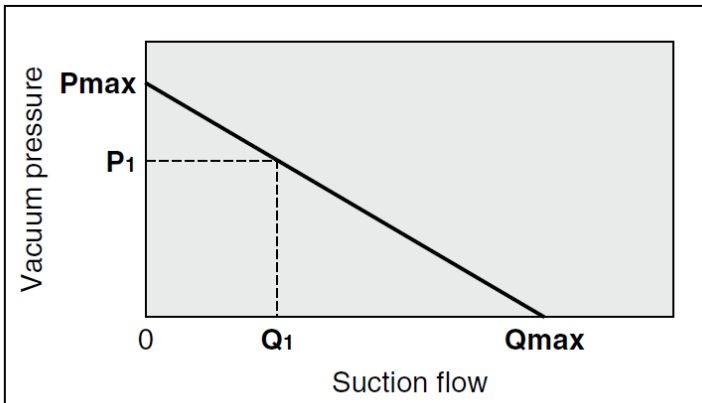

Flow rate characteristics are expressed in ejector vacuum pressure and suction flow. If suction flow changes, the vacuum pressure will also be changed. Normally this relationship is expressed in ejector standard operating pressure use. In the graph, Pmax is maximum vacuum pressure and Qmax is maximum suction flow. The values are specified according to catalog use. Changes in vacuum pressure are expressed in the below order.

1. When the ejector suction port is covered and made airtight, the suction flow becomes zero and vacuum pressure is at the maximum value (Pmax).
2. When the suction port is opened gradually, air can flow through, (air leakage), suction flow increases, but vacuum pressure decreases. (condition P1 and Q1)
3. When the suction port is opened further and fully opened, suction flow moves to the maximum value (Qmax), but vacuum pressure is near zero (atmospheric pressure).

As described above, the vacuum pressure changes when the suction flow changes. In other words, when there is no leakage from the vacuum port, the vacuum pressure can reach its maximum, but as the amount of leakage increases, the vacuum pressure decreases. When the amount of leakage and the maximum suction flow become equal, the vacuum pressure becomes almost zero.

In the case when a ventilative or leaky workpiece should be gripped, take note that vacuum pressure will not rise.

3.3. How to calculate theoretical lifting force

*This manual shows how to calculate theoretical lifting force only. Refer to the catalog of suction cups for further detail of suction cup selection method.

■ How to calculate theoretical lifting force

The theoretical lifting force of a cup can be found by calculation or from the theoretical lifting force table.

Calculation

$$W = P \times S \times 0.1 \times \frac{1}{t}$$

W: Lifting force [N]
 P: Vacuum pressure [kPa]
 S: Cup area [cm²]
 t: Safety factor Horizontal lifting: 4 or more
 Vertical lifting: 8 or more

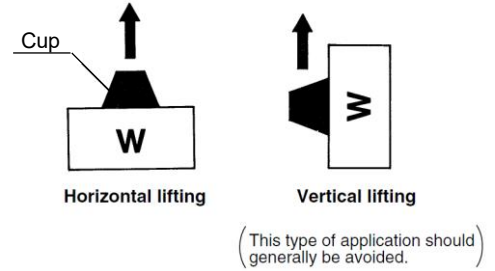

Theoretical lifting force table

The theoretical lifting force (not including the safety factor) can be determined by the cup diameter and vacuum pressure.

The required lifting force can then be determined by dividing the theoretical lifting force by the safety factor t.

$$\text{Lifting force} = \text{Theoretical lifting force} / t$$

Theoretical lifting force (Theoretical lifting force = P x S x 0.1)

Cup diameter (Φ8 to Φ32)

Cup diameter [mm]		Φ8	Φ10	Φ13	Φ16	Φ20	Φ25	Φ32
S: Cup area [cm ²]		0.50	0.79	1.33	2.01	3.14	4.91	8.04
Vacuum pressure [kPa]	-85	4.2	6.6	11	17	26	41	68
	-80	4.0	6.2	10	16	25	39	64
	-75	3.7	5.8	10	15	23	36	60
	-70	3.5	5.5	9.3	14	22	34	56
	-65	3.2	5.1	8.6	13	20	31	52
	-60	3.0	4.7	8.0	12	18	29	48
	-55	2.7	4.3	7.3	11	17	27	44
	-50	2.5	3.9	6.7	10	15	24	40
	-45	2.2	3.5	6.0	9.0	14	22	36
-40	2.0	3.1	5.3	8.0	12	19	32	

3.4. How to order

■ Vacuum Gripper

Suction cup part *1 Refer to the table below for the applicable cups.

ZXP 7 A 41 - ZP 20 U N □ - X1

Vacuum Gripper

1) Body size

Symbol	Size
7	75mm

2) Cup mounting flange shape

Symbol	Shape
A	With flange (42 mm x 42 mm)
N	Without flange

3) Compatible robot manufacturer

Symbol	Robot manufacturer
41	OMRON TECHNICS TM1, TM12, TM14

4) Cup series

Symbol	Cup Series
ZP	Basic
ZP3P	Bellows type for film packaging workpieces
Nil	Without cup

5) Cup diameter

Symbol	Cup diameter
08	Φ8
10	Φ10
13	Φ13
16	Φ16
20	Φ20
25	Φ25
B25	Φ25
B30	Φ30
32	Φ32
Nil	Without cup

6) Cup form

Symbol	Type
U	Flat
C	Flat with rib
B	Bellows
UT	Thin flat
J	Multistage bellows
JT2	2.5-stage bellows
JT5	5.5-stage bellows
Nil	Without cup

7) Cup material

Symbol	Material
N	NBR
S	Silicone rubber (White) +2
U	Urethane rubber
F	FKM
SF	Silicone rubber (Blue) +2
Nil	Without cup

8) Attachment *3

Symbol	Attachment
Nil	With (guide) attachment
M	With mesh attachment

*2 The silicone material is compliant with the FDA (U.S. Food and Drug Administration) regulation 21CFR § 177.

*3 Only applicable to the cup form "JT□." Note that "M" applies only to cup form: JT2.

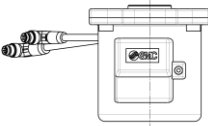

Without Flange

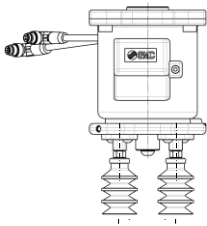

With Flange

· See the table below for the suction cup part combination.
 · Refer to the catalog of suction cup on the SMC website for the detail of suction cup.

*1

■ Suction Cup Part Numbers and Weight

ZXP7(A,N)41 - (4) (5) (6) (7) (8) -X1

Applicable cups					Cup part numbers							
(4) Cup series	(5) Cup diameter	(6) Cup form	(7) Cup material	(8) Attachment	Cup with adapter				Adapter unit (Vacuum inlet: Male thread M6 x 1)	Cup unit		
					Part number	Weight by cup material (g/cup)						
						N (NBR)	S/SF (Silicone)	U (Urethane)	F (FKM)			
ZP	08	U	*		ZPT08U*-A6	4	4	4	4	ZPT1-A6	ZP08U*	
ZP	08	B	*		ZPT08B*-A6	4	4	4	4		ZP08B*	
ZP	10	UT	*		ZPT10UT*-A6	4	4	4	4		ZP10UT*	
ZP	13	UT	*		ZPT13UT*-A6	4	4	4	4		ZP13UT*	
ZP	16	UT	*		ZPT16UT*-A6	4	4	4	4	ZP16UT*		
ZP	10	U	*		ZPT10U*-AS6	7	7	7	7	ZPT2-AS6	ZP10U*	
ZP	13	U	*		ZPT13U*-AS6	7	7	7	8		ZP13U*	
ZP	16	U	*		ZPT16U*-AS6	7	7	7	8		ZP16U*	
ZP	20	U	*		ZPT20U*-AS6	9	10	10	10		ZP20U*	
ZP	25	U	*		ZPT25U*-AS6	10	10	10	11	ZPT3-AS6	ZP25U*	
ZP	32	U	*		ZPT32U*-AS6	10	11	11	12		ZP32U*	
ZP	10	C	*		ZPT10C*-AS6	7	7	7	7		ZPT2-AS6	ZP10C*
ZP	13	C	*		ZPT13C*-AS6	7	7	7	7			ZP13C*
ZP	16	C	*		ZPT16C*-AS6	7	7	7	8	ZP16C*		
ZP	20	C	*		ZPT20C*-AS6	9	10	10	11	ZP20C*		
ZP	25	C	*		ZPT25C*-AS6	10	10	10	11	ZPT3-AS6	ZP25C*	
ZP	32	C	*		ZPT32C*-AS6	10	11	11	12		ZP32C*	
ZP	10	B	*		ZPT10B*-AS6	7	7	7	8		ZPT2-AS6	ZP10B*
ZP	13	B	*		ZPT13B*-AS6	7	8	8	8			ZP13B*
ZP	16	B	*		ZPT16B*-AS6	8	8	8	9	ZP16B*		
ZP	20	B	*		ZPT20B*-AS6	11	11	11	13	ZP20B*		
ZP	25	B	*		ZPT25B*-AS6	11	12	12	14	ZPT3-AS6	ZP25B*	
ZP	32	B	*		ZPT32B*-AS6	14	15	15	18		ZP32B*	
ZP	20	UT	*		ZPG20UT*-7A-X2	4	4	4	4		ZPT1-A6	ZP2-20UT*
ZP	16	J	*		ZPG16J*-7A-X2	8	8	8	9		ZPT2-AS6	ZP2-16J*
ZP	B25	J	*		ZPGB25J*-7A-X2	14	15	15	18	ZPT3-AS6	ZP2-B25J*	
ZP	B30	J	*		ZPGB30J*-7A-X2	18	19	19	25		ZP2-B30J*	
ZP3P	20	JT2	SF		ZP3PG20JT2SF-7A-X2	-	21	-	-		ZP3PA-T1JT-7A-X2	ZP3P-20JT2SF-W
ZP3P	20	JT2	SF	M	ZP3PG20JT2SF-M-7A-X2	-	21	-	-			ZP3P-20JT2SF-WM
ZP3P	32	JT2	SF		ZP3PG32JT2SF-7A-X2	-	48	-	-	ZP3PA-T2JT-7A-X2	ZP3P-32JT2SF-W	
ZP3P	32	JT2	SF	M	ZP3PG32JT2SF-M-7A-X2	-	48	-	-			ZP3P-32JT2SF-WM
ZP3P	20	JT5	SF		ZP3PG20JT5SF-7A-X2	-	23	-	-	ZP3PA-T1JT-7A-X2	ZP3P-20JT5SF-WG	
ZP3P	25	JT5	SF		ZP3PG25JT5SF-7A-X2	-	25	-	-		ZP3P-25JT5SF-WG	
ZP3P	32	JT5	SF		ZP3PG32JT5SF-7A-X2	-	54	-	-		ZP3PA-T2JT-7A-X2	ZP3P-32JT5SF-WG

Input the material symbol ("N", "S", "U", or "F") into the □ in the part number.

4. Mounting

4.1. Mounting

■ Mounting procedure

- 1) Confirm the gasket seal on the adapter, then mount 4 cups with adapter to the vacuum gripper.
(Tightening torque: $1\text{N} \cdot \text{m}$ or tighten for 45 degrees using a spanner after tightening by hand)
- 2) Mount parallel pin to the robot flange pin hole.
- 3) Align the parallel pin of the robot flange with the robot mounting flange, and assemble them with bolts included in the accessories. (Tightening torque: $5.2 \pm 0.5\text{Nm}$)
- 4) Tighten the vacuum gripper to the robot mounting flange.
(Tightening torque: $5.2 \pm 0.5\text{Nm}$)

Removal should be performed by following the mounting procedure in reverse.

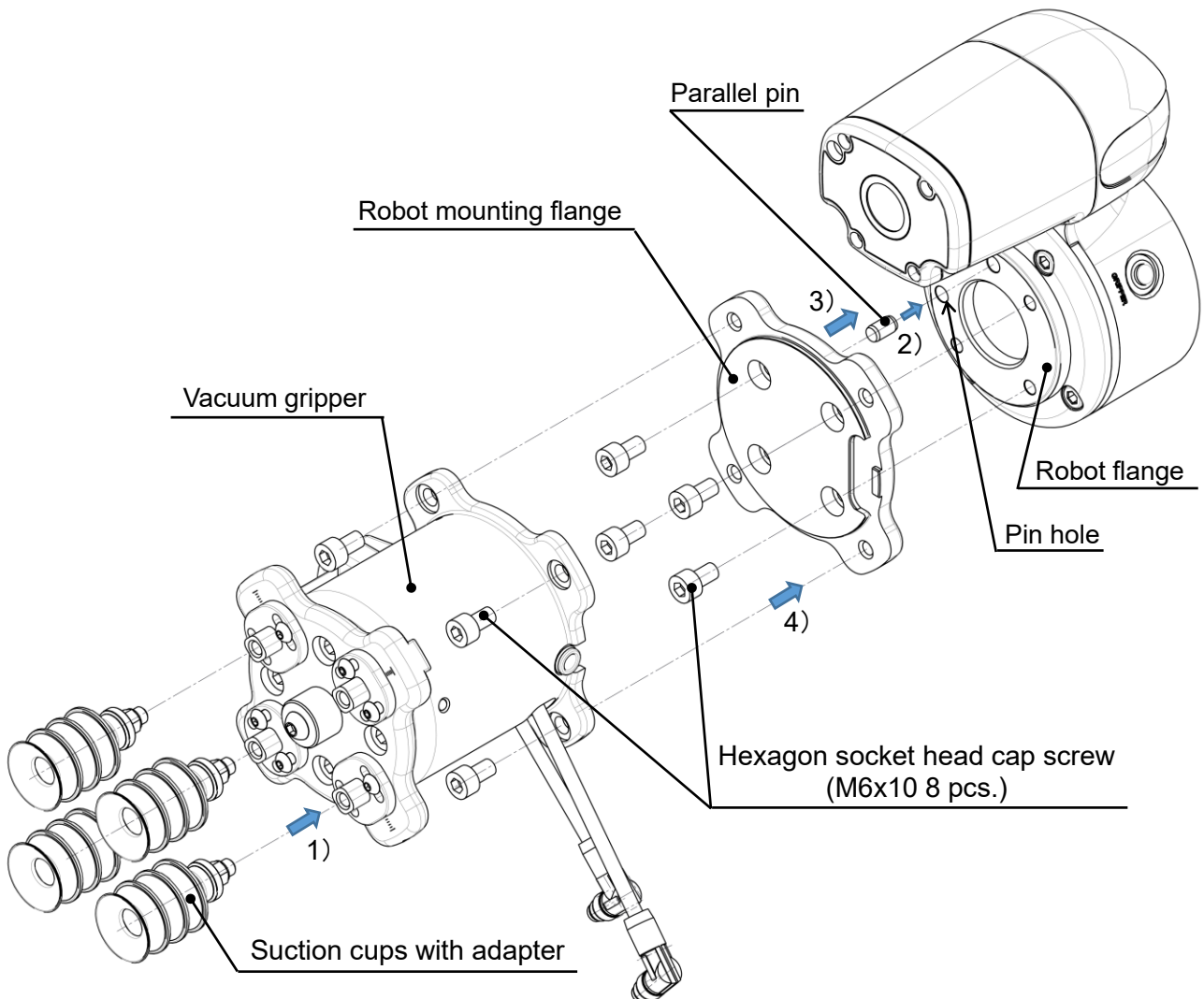
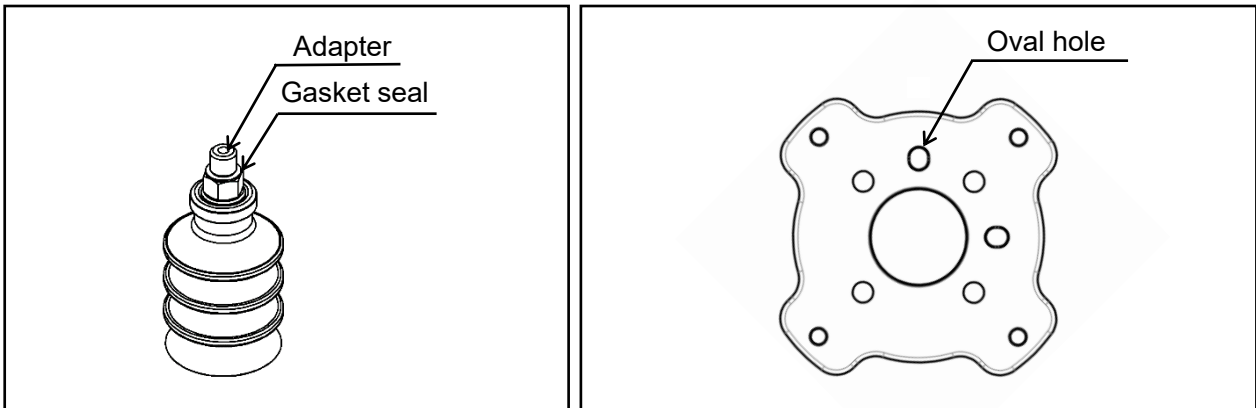

 Caution

Vacuum gripper direction can be changed in 90-degree increments when attached to a robot. At that time, install it in the direction of the lower figure. (90-degree between the camera module and the cover of the vacuum gripper.)

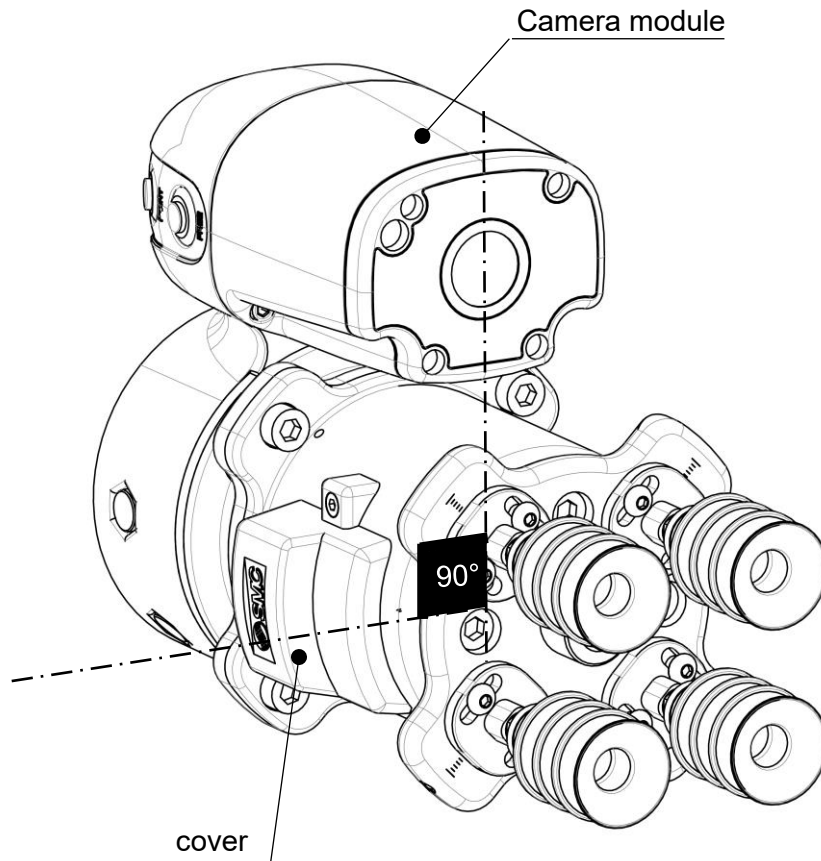

4.2. Wiring

■ Mount the M8 connector cables

Mount the M8 connector cables (plug) to the M8 connector (socket) of the robot tool flange.

*Do not energize while securing the connector.

*Check that the connector is not loose

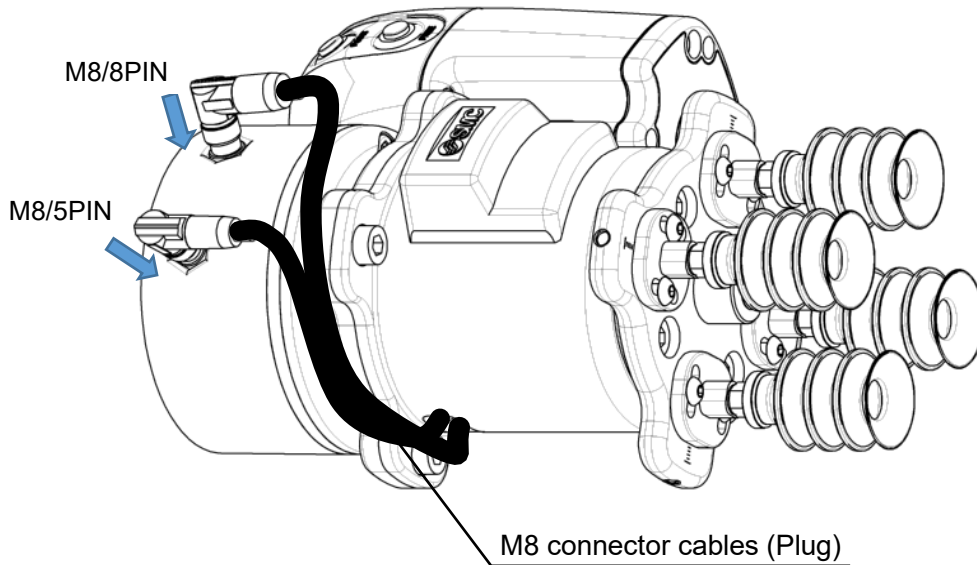

■ M8/8PIN

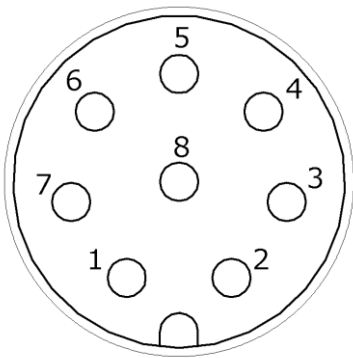

M8/8PIN plug angle

Pin	Wire color	Function
1	White	Power supply voltage (24V)
2	-	N.C.(Non connection)
3	-	N.C.(Non connection)
4	-	N.C.(Non connection)
5	Gray	Pilot valve for supply *
6	Pink	Release valve *
7	-	N.C.(Non connection)
8	-	N.C.(Non connection)

* Set the polarity of the robot output to NPN.

■ M8/5PIN

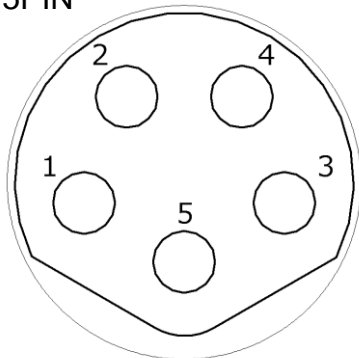

M8/5PIN plug angle

Pin	Wire color	Function
1	Brown	Power supply voltage (24V)
2	-	N.C.(Non connection)
3	-	N.C.(Non connection)
4	Black	Pressure sensor output
5	Gray	Power supply voltage (GND)

4.3. Piping

■ Tube

Connect a tube (applicable tube O.D. $\varnothing 6$) to the air pressure supply (P) port.
 (Refer to the P.30 " 2) Tube attachment ")

To remove the tube, push the release button and pull out the tube.

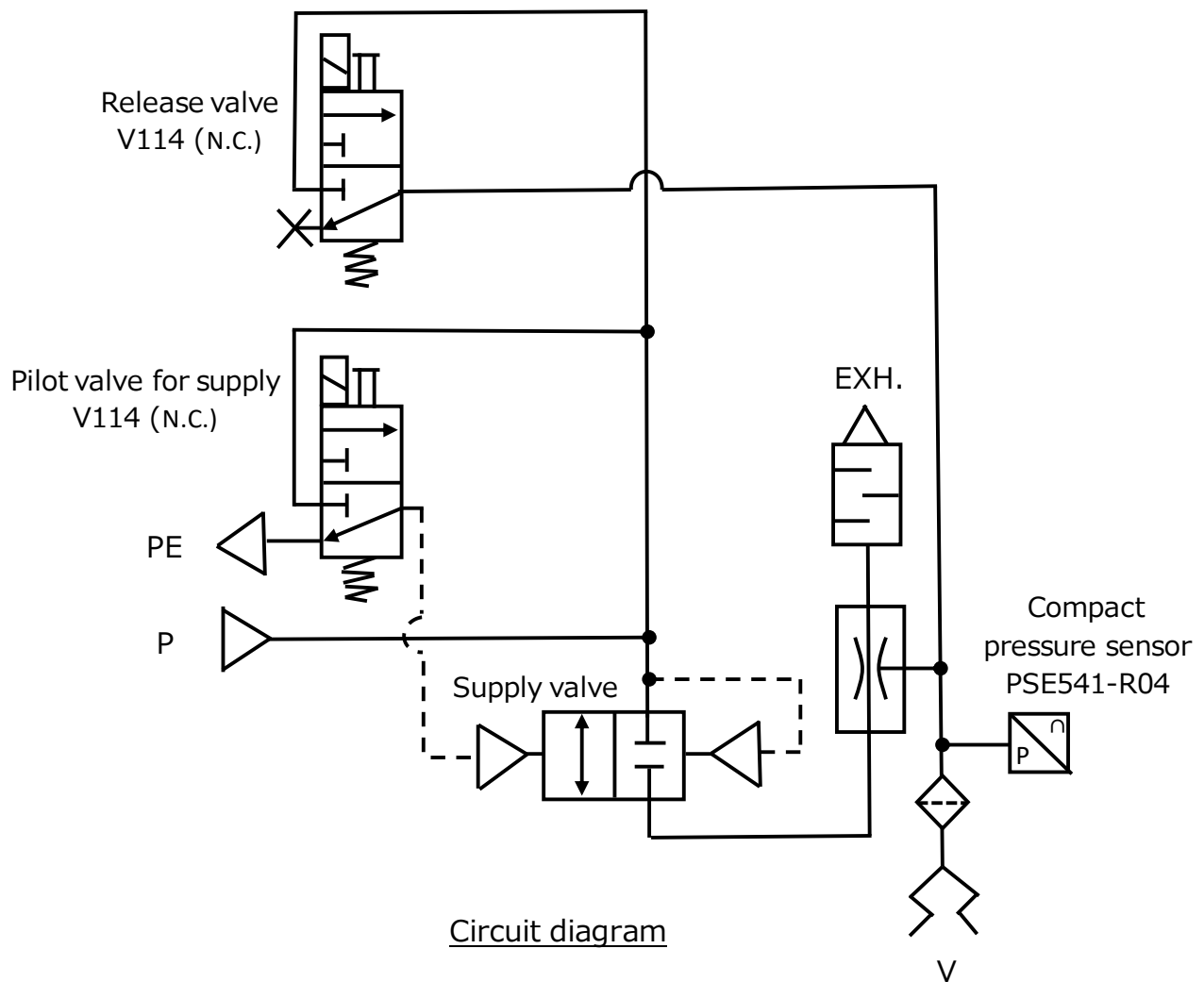
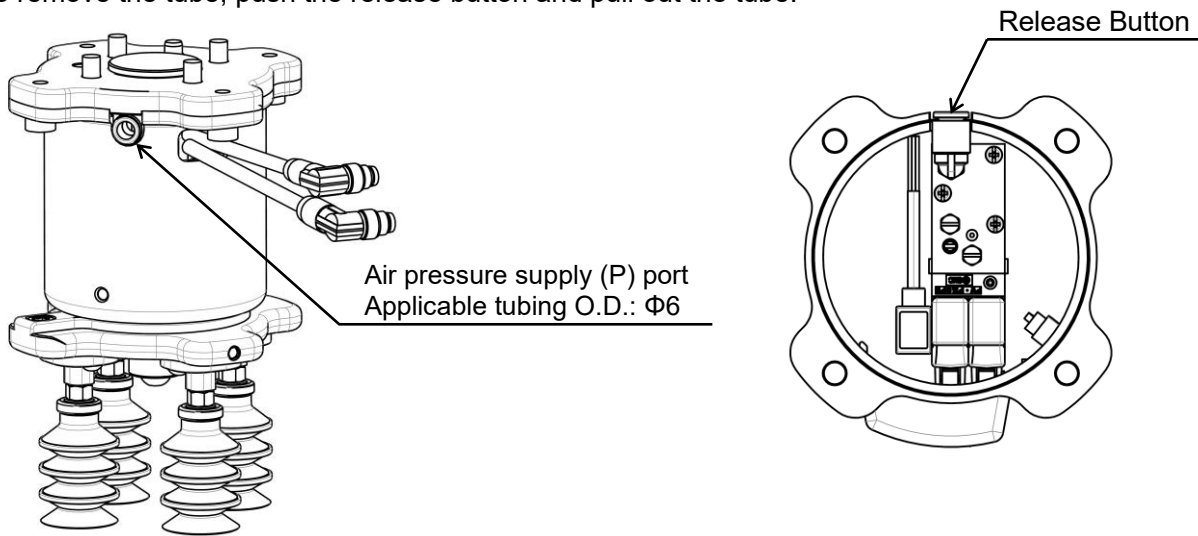

4.4. TMComponent

TMComponent is an independent software package for the robot applications and you need to import the software package to use in TMflow (robot software) directly.

Here is the list of the SMC Vacuum Gripper TMComponents.

- VacuumSensor_SMC_ZXP_***_Adsorb (The gripper adsorbs in vacuum to grip a workpiece)
- VacuumSensor_SMC_ZXP_***_Release (The gripper blows off to release a workpiece)

Note) *** is the version number starting from 001.

Import TMComponent

1. Download the TMComponent from the SMC website.
2. Label the USB drive with "TMROBOT".
3. Place the downloaded the zipped component files in the USB with the folder directory TMROBOT:\TM_Export\TMComponent\ComponentObject\.
4. Insert the USB storage device in the robot controller
5. In TMflow, click the **triple bar** icon and select **System**
6. Select **Import/Export** and click **Import**. Then select the TMComponent in the Robot List window and click on **OK**.
7. Click on the **Component** button of the Import navigation pane. Then select the relevant SMC components to be added and click **Import**.

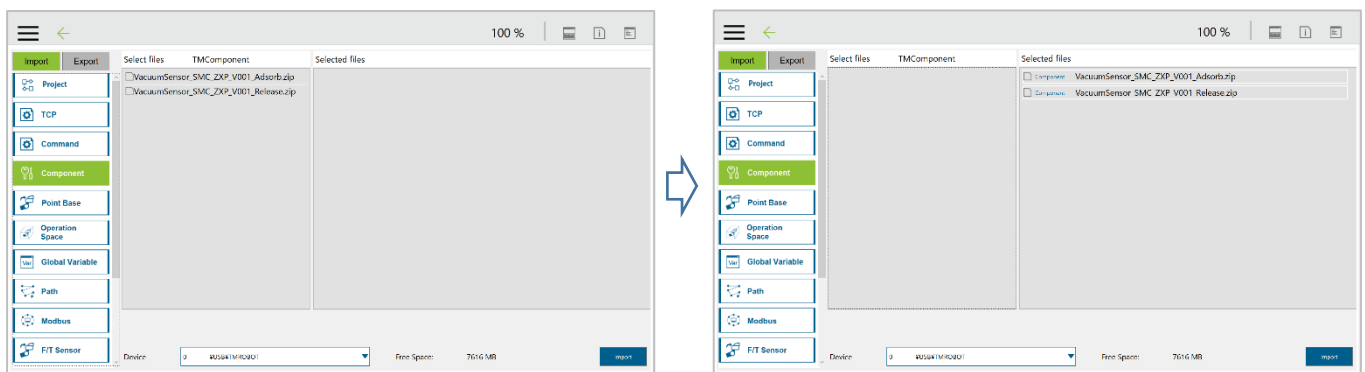

Enable TMComponent

8. Click the **triple bar** icon and go back to the main menu. Then select **Setting** to display the System Setting window.
9. Click on the **Component** icon
10. Enable required Components in the Component List by ticking the radio button beside each of them. A Component that is enabled displays a green radio button. Then click on the **Save** button.

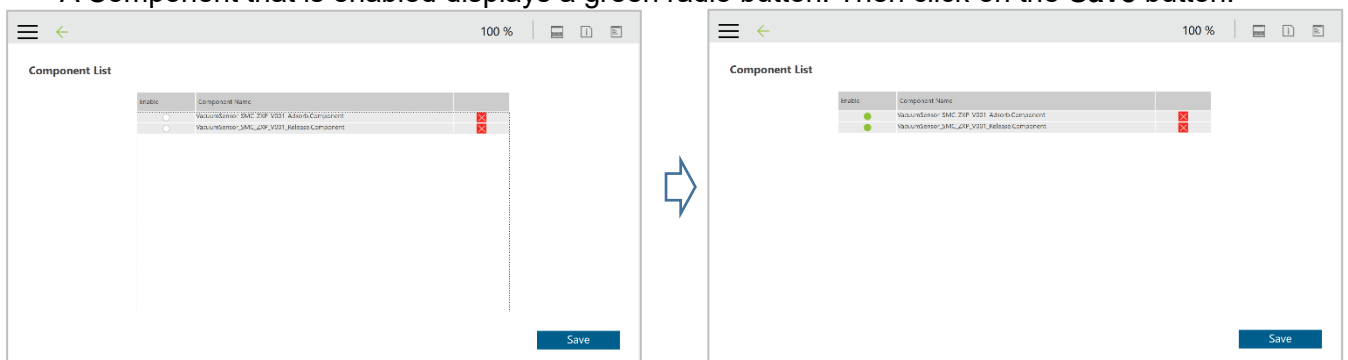

Configure gripper button

The user can assign SMC Gripper Components to the Gripper button and use to adsorb and release the workpiece.

1. Click the **triple bar** icon and go back to the main menu. Then select **Setting** icon.
2. Click on **Gripper Button** icon.
3. In the Gripper Button window, tick the **Using Customized Component** radio button and select the Component you want to assign to either one of the Gripper actions.

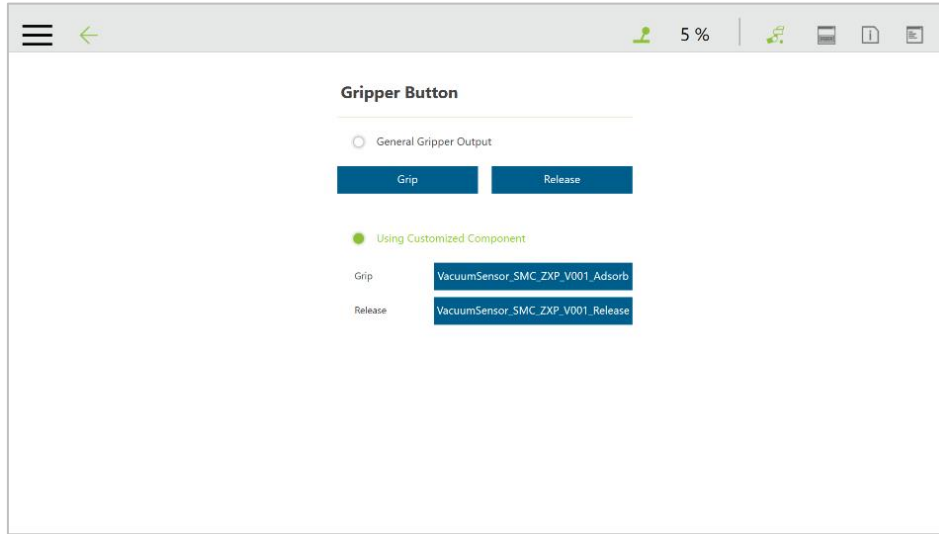

Use TMCComponent

Component Adsorb node

This component is used to grip a part by vacuum absorption.

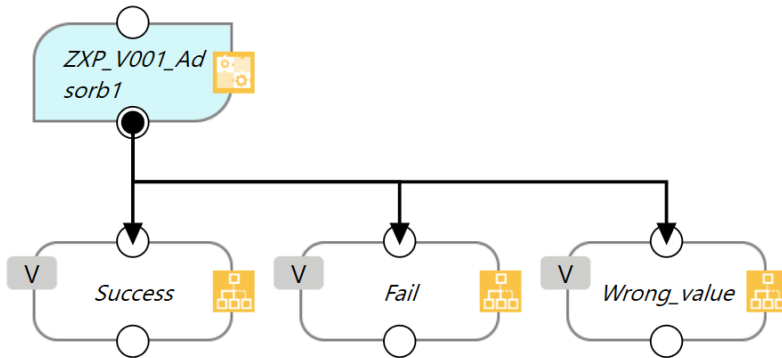

- Success : Adsorbs in vacuum and move to the next operation without checking the vacuum pressure level when Adsorb_and_ CheckVacuumLevel is set to false.

Adsorbs in vacuum and if the vacuum pressure level is reached to set value meaning a workpiece is gripped, move to the next operation when Adsorb_and_ CheckVacuumLevel is set to true.
- Fail : The vacuum pressure level is not reached to the set value and will not move to the next operation when Adsorb_and_ CheckVacuumLevel is set to true.
- Wrong_value : The set value of VacuumPressureLevel _Setting or AdsorbErrorDetectTime_ Setting is out of range.

Function	Type	Default	Description
Adsorb_and_ CheckVacuumLevel	bool	false	CheckVacuumLevel function enable or disable setting When set to false, adsorb in vacuum but not to check vacuum pressure level When set to true, adsorb in vacuum and check vacuum pressure level
VacuumPressureLevel _Setting	int	-60	Vacuum pressure level setting (Unit: kPa, Range: -100k..0kPa) Set the value of vacuum pressure level for detecting the absorption
AdsorbErrorDetectTime _Setting	int	50	Adsorb error detection time setting (Unit: ms, Range: 50..5000ms) Set the time to continuously check the vacuum pressure level. If the vacuum pressure level is not reached to the set value within the adsorb error detection time, it means unsuccessful absorption.

Component Release node

This component is used to release a workpiece by blowing off. The vacuum pressure level is not checked in this case.

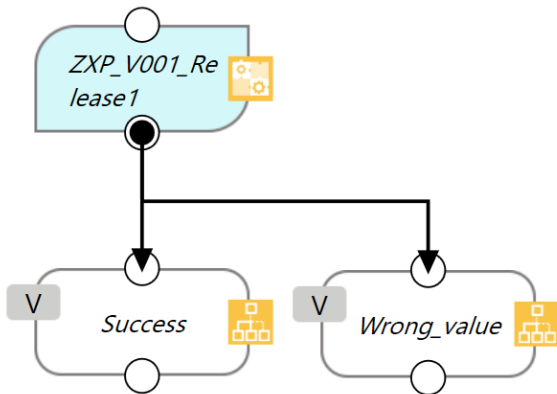

- Success : Blow off and move to the next operation
- Wrong_value : The set value of BlowOffTime_Setting is out of range

Function	Type	Default	Description
BlowOffTime_Setting	int	100	Blow off time setting (Unit: ms, Range: 0..1000ms) Set the time to blow off

5. Dimensions

5.1. Vacuum Gripper

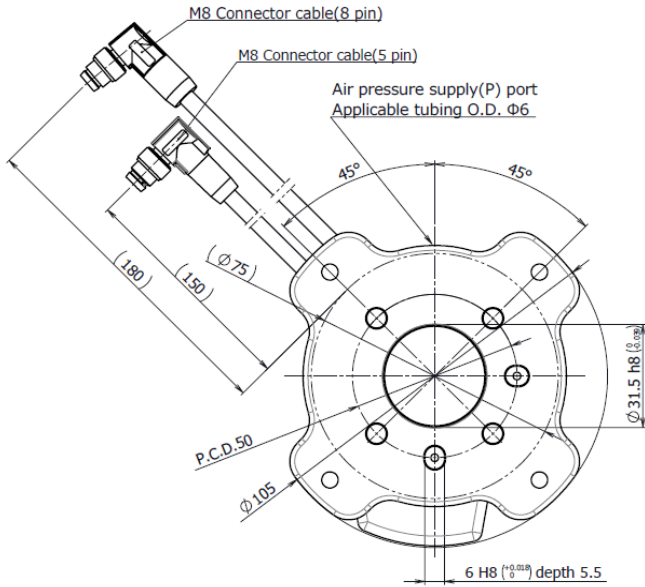

Robot mounting flange
(Conforming to ISO 9409-1-50-4-M6)

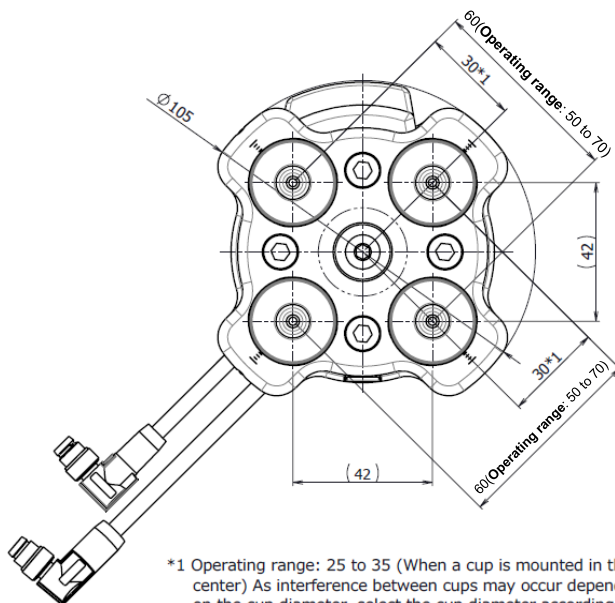
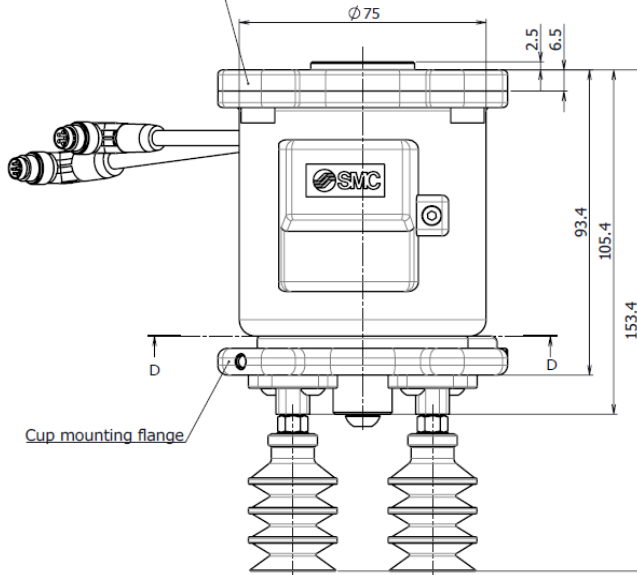

*1 Operating range: 25 to 35 (When a cup is mounted in the center) As interference between cups may occur depending on the cup diameter, select the cup diameter according to the pitch to be used.

* Cup distance is changeable.

Without cup mounting flange

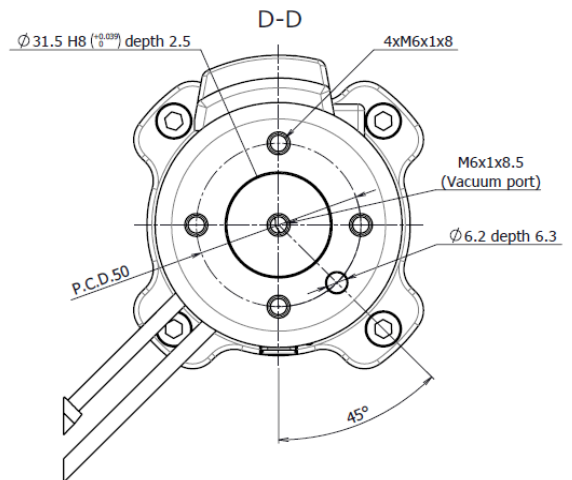

* The vacuum port doesn't come with mesh.

5.2. Center of gravity (ZXP7A41-ZPB25JN-X1)

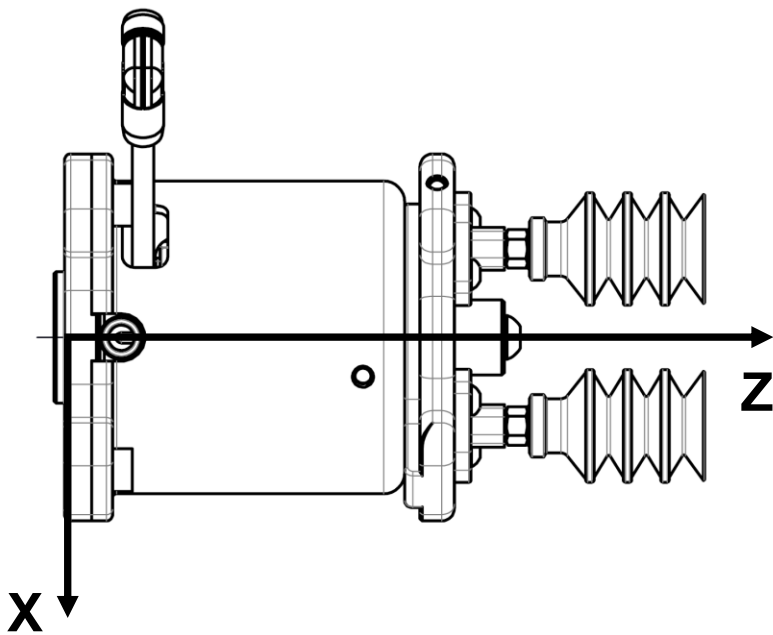
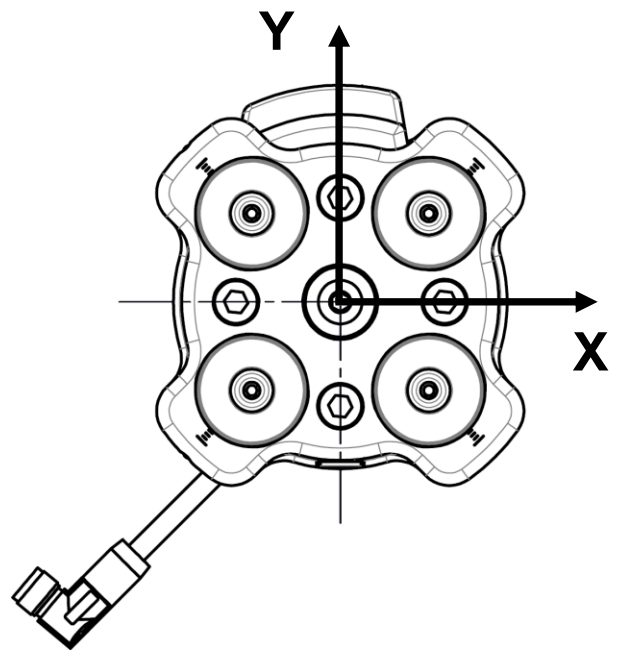
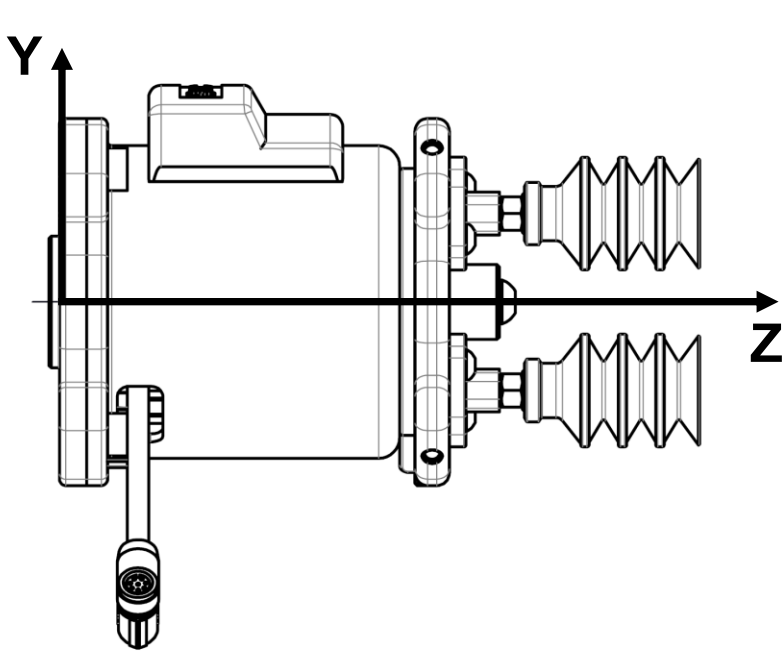

(Unit : mm)

Center of gravity		
X	Y	Z
0.01	0.68	56.48

5.3. Suction cup with adapter

*It is shown here for representative model only. See the suction cup catalog for the other models.

Model : ZPT*U*-AS6
(Suction cup form : Flat type)

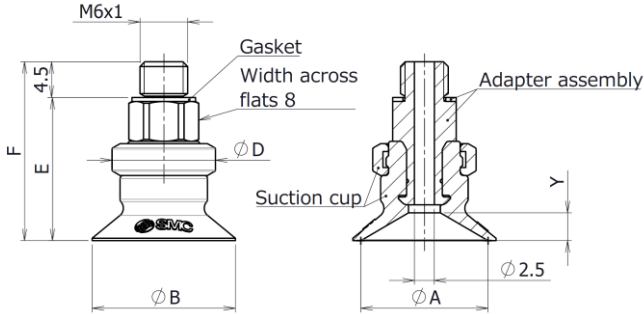

Dimensions

Model	A	B	D	E	F	Y
ZPT10U*-AS6	10	12	13	17.5	22	3
ZPT13U*-AS6	13	15		18	22.5	3.5
ZPT16U*-AS6	16	18	15	19.5	24	4
ZPT20U*-AS6	20	23		20	24.5	4.5
ZPT25U*-AS6	25	28				
ZPT32U*-AS6	32	35				

Model : ZPT*C*-AS6
(Suction cup form : Flat type with ribs)

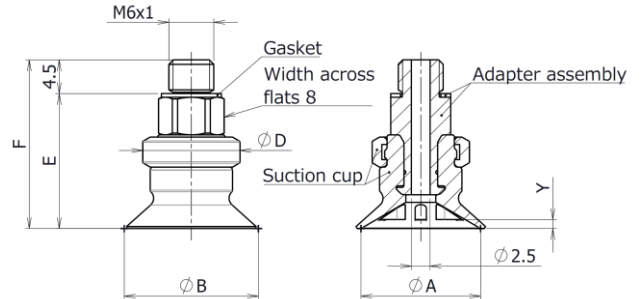

Dimensions

Model	A	B	D	E	F	Y
ZPT10C*-AS6	10	12	13	17.5	22	1.7
ZPT13C*-AS6	13	15		18	22.5	1.8
ZPT16C*-AS6	16	18		19.5	24	1.7
ZPT20C*-AS6	20	23	15	20	24.5	2.3
ZPT25C*-AS6	25	28				
ZPT32C*-AS6	32	35				

Model : ZPT*B*-AS6
(Suction cup form : Bellows type)

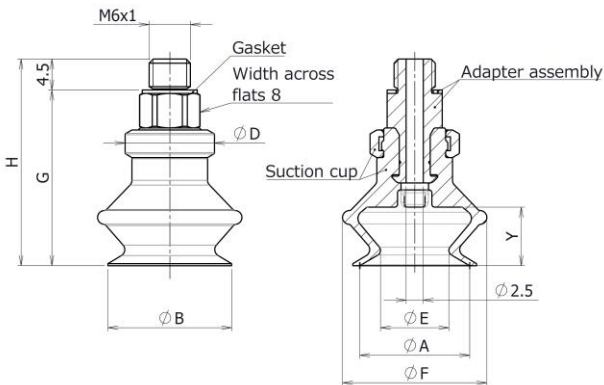

Dimensions

Model	A	B	D	E	F	G	H	Y
ZPT10B*-AS6	10	12	13	5.5	13.5	21.5	26	5.5
ZPT13B*-AS6	13	15		8.7	19	24	28.5	7.5
ZPT16B*-AS6	16	18		10	21	25.5	30	8.5
ZPT20B*-AS6	20	22	15	12.6	25	29	33.5	10.5
ZPT25B*-AS6	25	27		16	28	29.5	34	
ZPT32B*-AS6	32	34		18.9	37	34.5	39	14

Model : ZPG20UT*-7A-X2
(Suction cup form : Thin flat type)

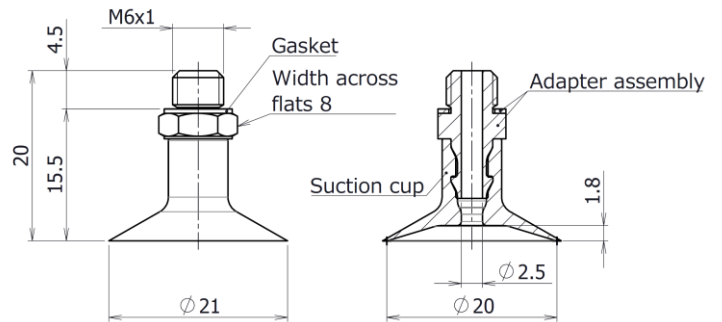

Model : ZPG16J*-7A-X2
 (Suction cup form : Multistage bellows type 2.5-Stage)

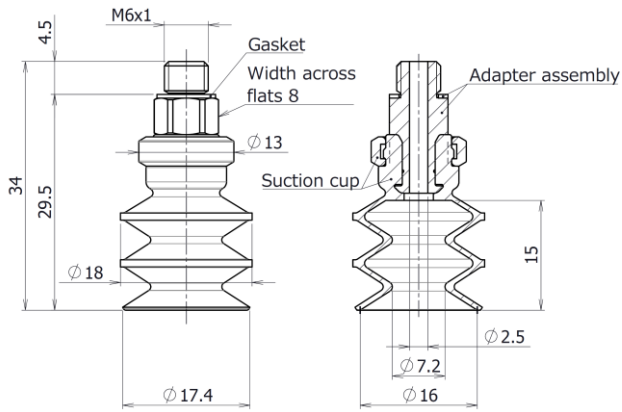

Model : ZPG(B25,B30)J*-7A-X2
 (Suction cup form : Multistage bellows type 3.5-Stage)

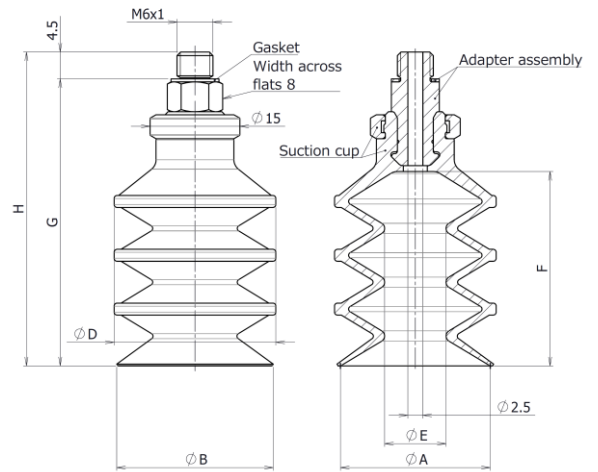

Dimensions

Model	A	B	D	E	F	G	H
ZPGB25J*-7A-X2	25	26	27	10.2	32.5	48	52.5
ZPGB30J*-7A-X2	30	33	32	13.8	38	54.5	59

Model : ZP3PG(20,25)JT5SF-7A-X2

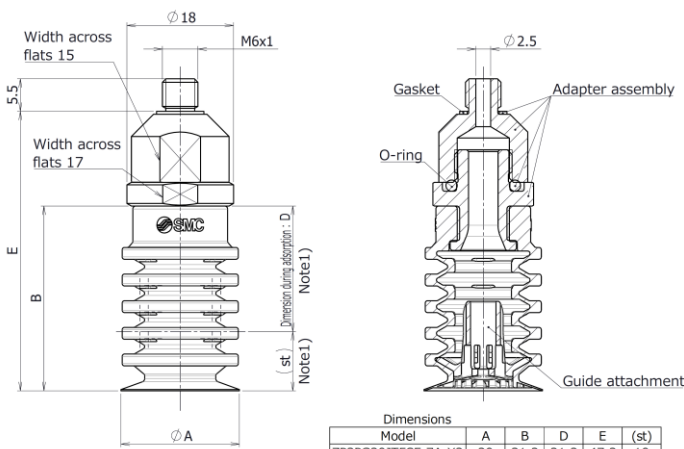

Model	A	B	D	E	(st)
ZP3PG20JT5SF-7A-X2	20	31.2	21.2	47.2	10
ZP3PG25JT5SF-7A-X2	25	35	23	51	12

Model : ZP3PG32JT5SF-7A-X2

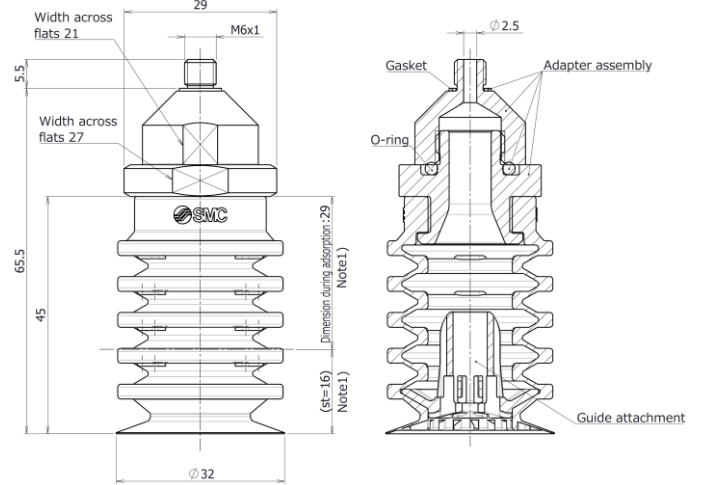

Note1) "D" and (st) indicate the reference value during gripping at vacuum pressure: -85[kPa].

6. How to change the number of cups

6.1 Change to 1 cup (with flange)

1. Removal of the cup.

- (1) Remove the suction cup with adapter from plate B using a spanner.
- (2) Loosen the bolt (M4 x 8), then remove plate B from plate A.
Be careful not to lose the O-ring.
- (3) Loosen the bolt for sealing (M6X8), then remove the cup from plate A.

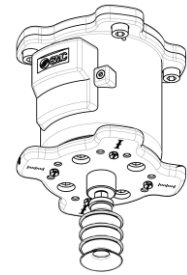

Completion drawing

2. Mounting of the plug and suction cup with adapter

- (1) Confirm the gasket seal in the accessory plug, then mount the plugs to plate A.
(4 places)
- (2) Confirm the gasket seal in the adapter, then mount the suction cup with adapter removed in the process (1) to plate A.

Reassemble the parts by reversing the disassembling process with specified tightening torque.

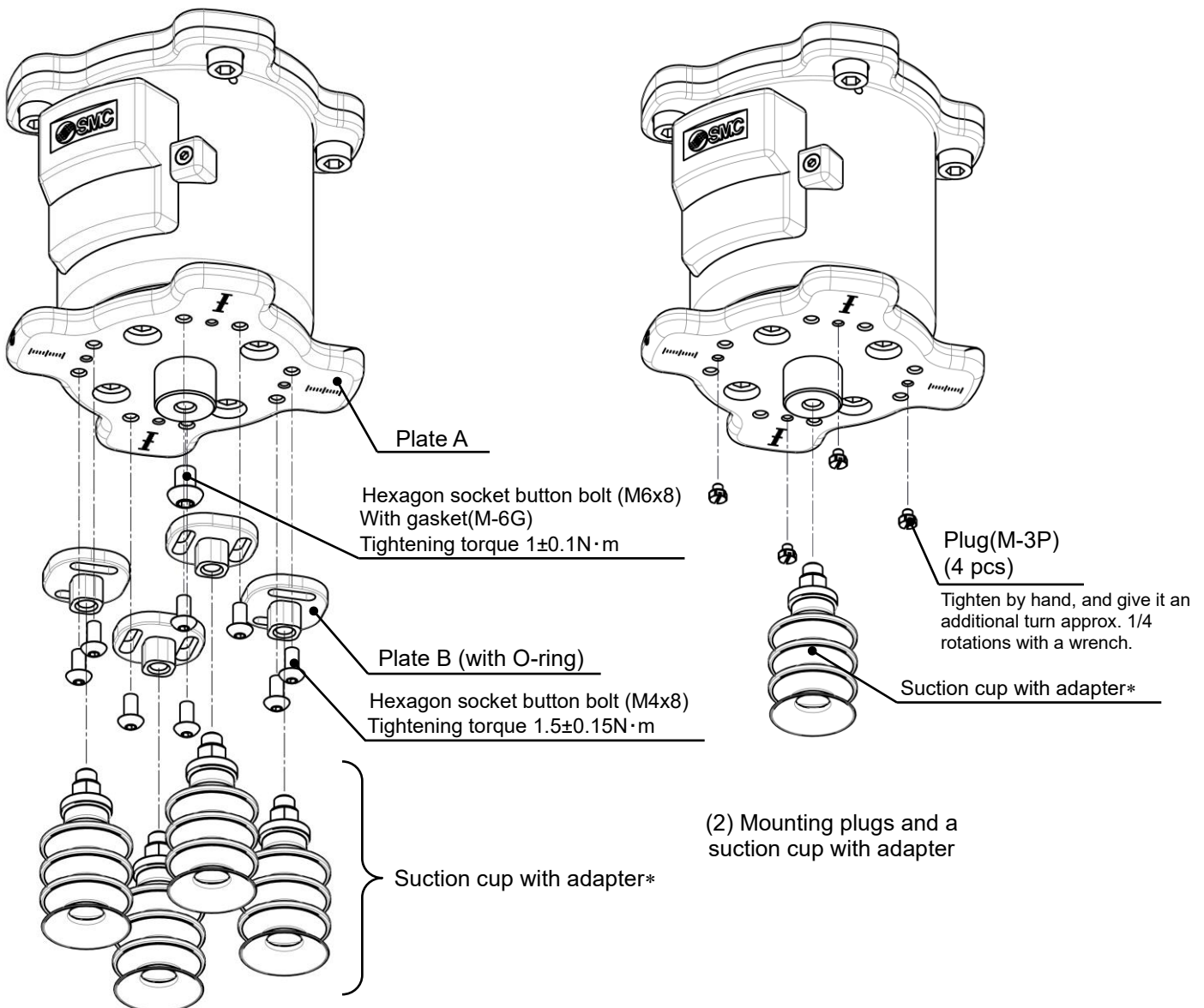

(1) Disassemble the suction cups with adapter

Caution

- * Tightening torque: $1 \text{ N} \cdot \text{m}$, (As reference, tighten by 45 degrees using a spanner after tightening by hand))
If tightened excessively, thread portion may be damaged and gasket may be deformed. This will cause air leakage. Insufficient tightening may loosen the thread or cause air leakage.

6.2 Change to 1 cup (without flange)

*No mesh in the vacuum (V) port. If the mesh is necessary in the vacuum (V) port, use the vacuum gripper with cup mounting flange.

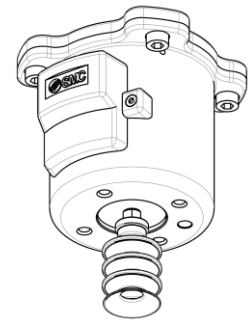

Completion drawing

1. Removal of the cup mounting flange

- (1) Loosen the bolt (M6 x 10), then remove the cup mounting flange.
Be careful not to lose the O-ring.
- (2) Remove the parallel pin.

2. Mounting of the suction cup with adapter

- (1) Remove the suction cup with adapter from the flange with cup removed in the process 1 above.
- (2) Confirm the gasket seal in the adapter, then mount the suction cup with adapter removed in the process (1) to the product.

Reassemble the parts by reversing the disassembling process with specified tightening torque.

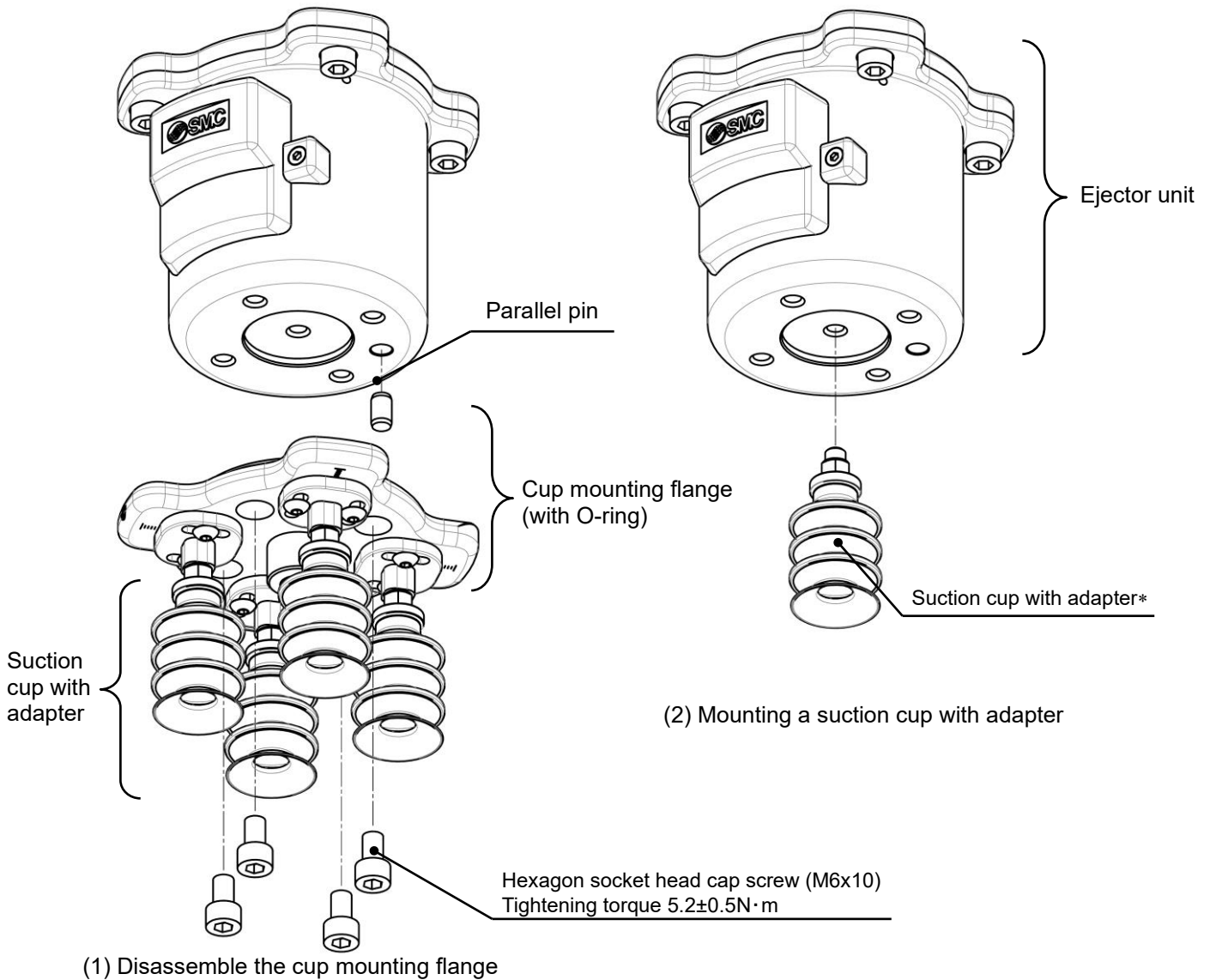

Caution

* Tightening torque: 1N · m, (As reference, tighten by 45 degrees using a spanner after tightening by hand))
If tightened excessively, thread portion may be damaged and gasket may be deformed. This will cause air leakage. Insufficient tightening may loosen the thread or cause air leakage.

6.3 Change to 2 cups

1. Removal of the suction cup with adapter
 - (1) Remove the suction cup with adapter from the plate B using a spanner.
 - (2) Loosen the bolt (M4 x 8), then remove plate B from plate A.
Be careful not to lose the O-ring.

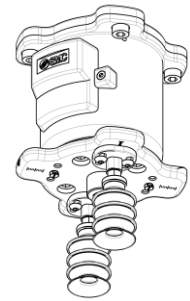

Completion drawing

2. Mounting of the plug

Confirm the gasket seal in the plug, then mount the plugs to plate A.
Reassemble the parts by reversing the disassembling process with specified tightening torque.

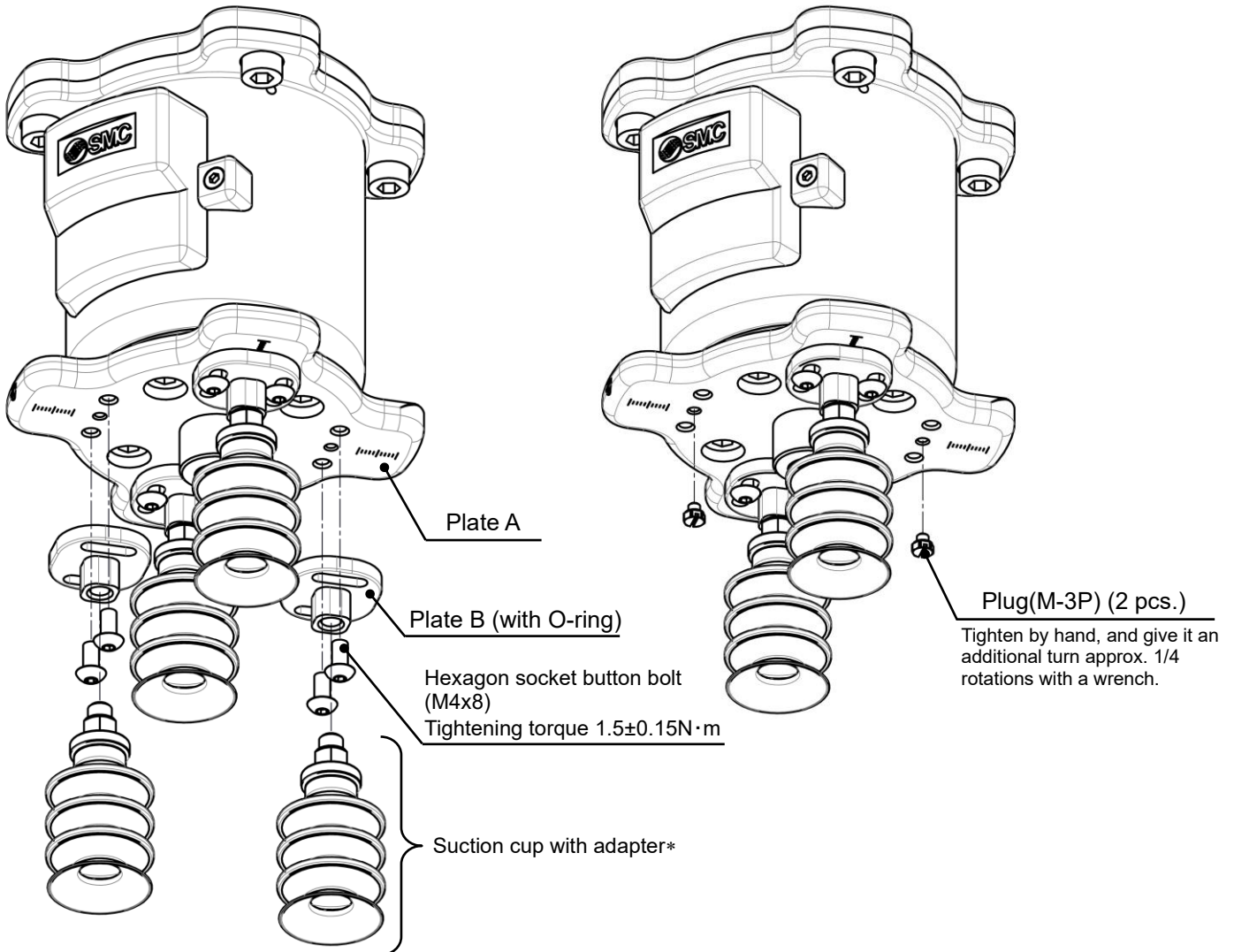

(1) Disassemble the suction cups with adapter

(2) Plug mounting

Caution

- * Tightening torque: 1N · m, (As reference, tighten by 45 degrees using a spanner after tightening by hand)
If tightened excessively, thread portion may be damaged and gasket may be deformed. This will cause air leakage. Insufficient tightening may loosen the thread or cause air leakage.

7.Maintenance

Implement the maintenance and check shown below in order to use the vacuum gripper safely and in an appropriate way for a long period of time.

7.1. Maintenance for vacuum gripper

Caution

1) **Check before and after the maintenance work**

When the product is to be removed, turn off the power supply, and be sure to cut off the supply pressure and exhaust the compressed air. Confirm that the air is released to atmosphere.

When mounting the product after the maintenance work, supply compressed air, connect to the power, check if it functions properly and have a leakage inspection.

2) **Maintenance should be performed according to the procedure indicated in the Operation Manual.**

Improper handling can cause damage and malfunction of equipment and machinery.

3) **Maintenance work**

Compressed air can be dangerous when handled incorrectly. Therefore, in addition to observing the product specifications, replacement of elements and other maintenance activities should be performed by personnel with sufficient knowledge and experience pertaining to pneumatic equipment.

4) **Draining**

Remove condensate from air filters and mist separators regularly. If the collected drainage is drained to the downstream side, it can stick inside of the product, causing operation failure and failure to reach the specified vacuum pressure.

5) **Replace the silencer built into the vacuum gripper regularly.**

It is recommended to replace the silencer when the pressure drop reaches 5kPa as a guideline. The replacement cycle varies depending on the operating conditions, operating environment and supply air quality. However, if there is a vacuum pressure drop and/or delay in the vacuum (gripping) response time which causes problem with the settings during operation, stop the operation of the product and replace the silencer regardless of the above mentioned replacement guideline.

• **Part number for the silencer assembly for replacement: ZX1-HS1**

< Silencer Assembly Replacement Procedure >

- Remove the cover.
- Loosen the 2 cross-recessed pan head screws to remove the silencer assembly.
- Assemble the new silencer assembly.
- Mount the cover.

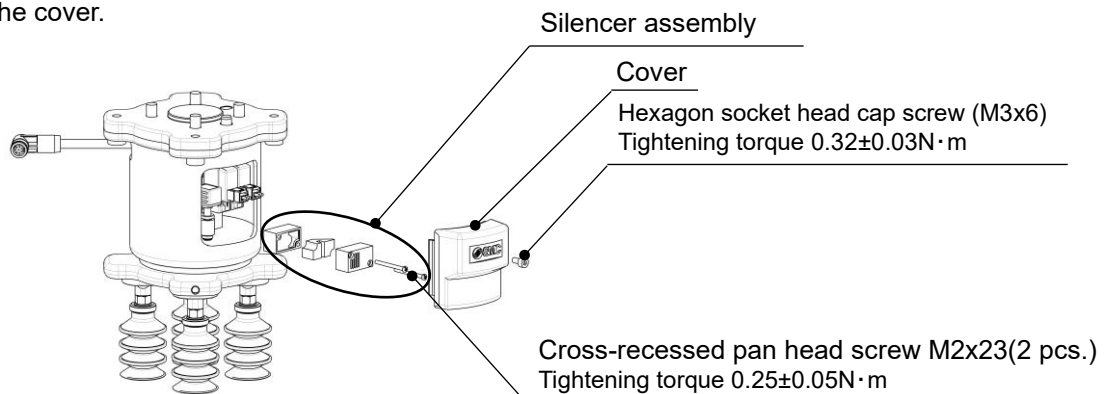

6) **Do not disassemble or modify the product, other than the replacement parts specified in this manual.**

7.2. Maintenance for suction cup

Caution

1) Suction cups are disposable. Replace them on a regular basis.

Continued use of suction cups will cause wear and tear on the gripping surface, and the exterior dimensions will gradually get smaller and smaller. As the cups' diameter gets smaller, their lifting force will decrease, though gripping will still remain possible.

It is extremely difficult to provide advice on the frequency of suction cup replacement. This is because there are numerous factors at work, including surface roughness, operating environment (temperature, humidity, ozone, solvents, etc.), and operating conditions (vacuum pressure, workpiece weight, pressing force of the suction cups on the workpieces, presence or absence of a buffer, etc.).

(The weakening of bent parts or the wear or sticking of rubber parts may occur with the bellows type cup.) Thus, the customer should decide when suction cups should be replaced, based on their condition at the time of initial use.

The bolts may become loose depending on the operating conditions and environment. Be sure to perform regular maintenance.

<How to replace the suction cup>

- Pull the lock ring upward, and, after lifting it up to the adapter, remove the old cup by pulling it downward.
 - While holding the lock ring in the raised position place a new cup onto the adapter.
 - Confirm that the cup is securely in place, and then return the lock ring to its original position.
- * The cup without lock ring is just inserted to the end of the adapter.

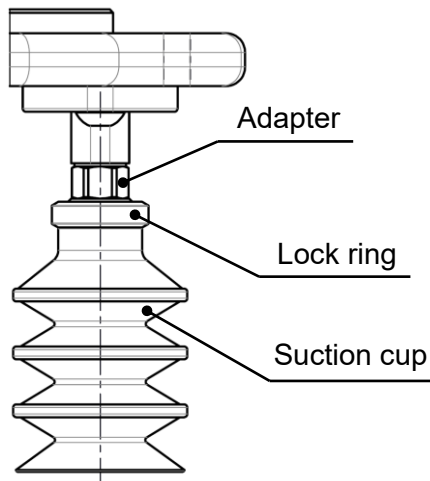

Cup assembly

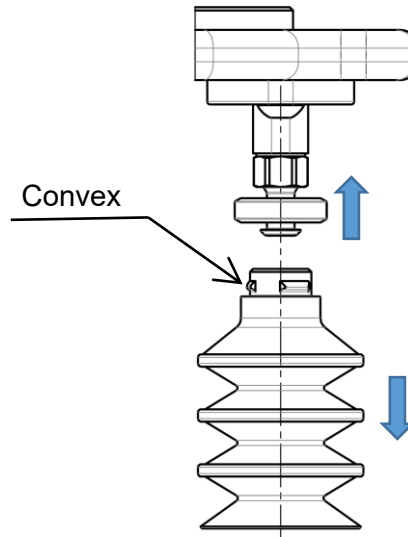

Cup disassembly

2) Mesh

If it is used in such a way that foreign matter is absorbed from the air or the workpiece, the mesh may become clogged. If the mesh is clogged, it will cause a reduction in the ejector performance. Clean the mesh periodically as necessary by washing, air blow and so on. If mesh clogging cannot be improved by cleaning, replace plate B.

•Part number for plate B for replacement : ZXP7-APL1-A-X1

Refer to "6.1 How to change to one cup (with flange)" for the replacement method.

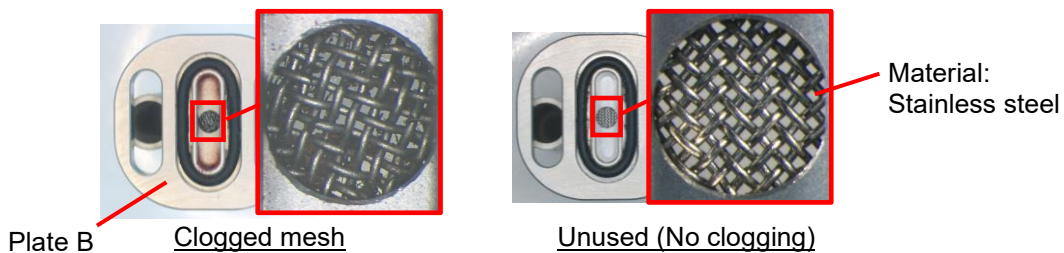

8. Precautions

8.1 Air supply

Warning

■ Use clean air.

It is recommended to use compressed air which purity class is 2:6:3 of ISO8573-1:2010. Supply air containing foreign matter, water, oil, condensate, etc., can cause malfunction of the supply valve and release valve. So, install air preparation equipment on the upstream side of the product (refer to the piping example below) and perform maintenance periodically to control the supply air properly.

Refer to "SMC Air Preparation System" for further details on compressed air quality.

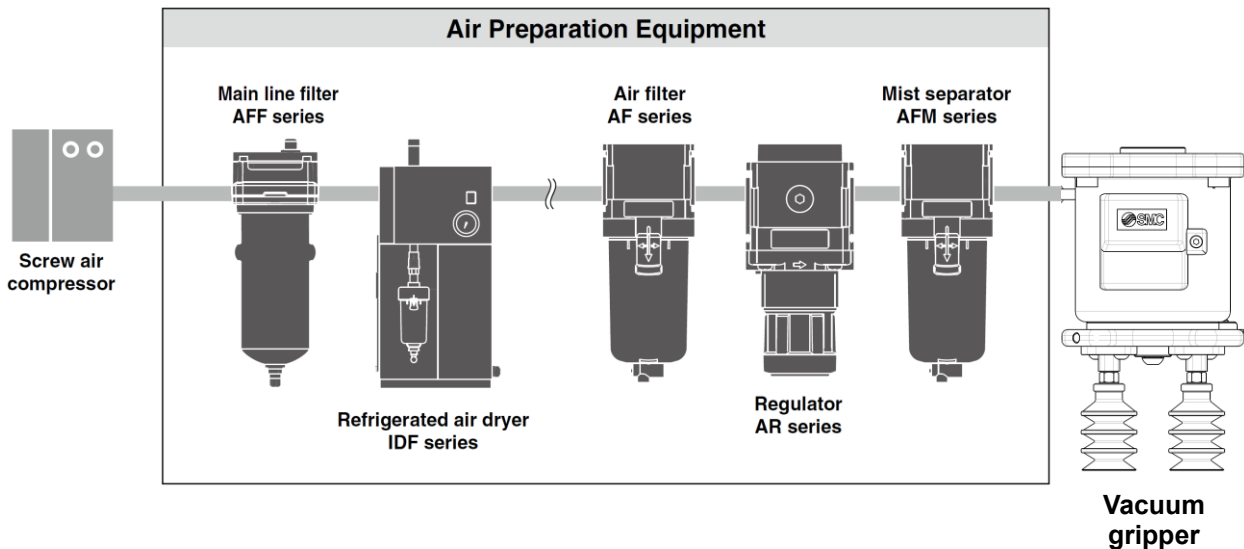

8.2 Vacuum gripper precautions

■ Designing

Warning

If power or air supply is shutdown, vacuum pressure may decrease and this product may drop a workpiece during gripping.

Please perform of safety measures by customer systems.

■ Mounting

Warning

1) Tighten to the specified tightening torque.

If the tightening torque is exceeded, the body and the mounting screws may break. However, insufficient torque may cause displacement of the body and loosening of the mounting screws.

2) Hold the product itself when handling.

Do not pull the M8 connector cable strongly or lift up the product by holding this cable. It can cause the malfunction of the product.

■ Wiring

Warning

1) Do not wire while energizing the product.

Doing so may result in damage to the internal parts of the solenoid valve or pressure sensor. In some cases, this damage may result in a malfunction.

2) Do not disassemble the M8 connector cable or make any modifications, including additional machining.

Doing so may cause human injury and/or an accident.

Caution

1) Avoid repeatedly bending or stretching the M8 connector cable as well as applying force to it.

■ Piping

Caution

1) **Flushing of the inside of the pipes**

Before piping is connected, it should be thoroughly blown out with air (flushing) or washed to remove chips, cutting oil, and other debris from inside the pipe.

2) **Tube attachment**

- Take a tube having no flaws on its periphery and cut it off at a right angle. When cutting the tube, use tube cutters TK-1,2,3,5, or 6. Do not use pliers, nippers, scissors, etc. If cutting is done with tools other than tube cutters, the tube may be cut diagonally or become flattened, etc., making a secure installation impossible, and causing problems such as the tube pulling out after installation or air leakage. Allow some extra length in the tube.
- Grasp the tube and push it in slowly, inserting it securely all the way into the fitting.
- After inserting the tube, pull on it lightly to confirm that it will not come out. If it is not installed securely all the way into the fitting, this can cause problems such as air leakage or the tube pulling out.

3) **Tube detachment**

- Push in the release button sufficiently, pushing its collar equally around the circumference.
- Pull out the tube while holding down the release button so that it does not come out. If the release button is not pressed down sufficiently, there will be increased bite on the tube and it will become more difficult to pull it out.
- When the removed tube is to be used again, cut off the portion which has been chewed before reusing it. If the chewed portion of the tube is used as is, this can cause trouble such as air leakage or difficulty in removing the tube.

4) **Other Tube Brands**

When using other than SMC brand tube, confirm that the following specifications are satisfied with respect to the tube outside diameter tolerance.

- Nylon tube Within ± 0.1 mm
- Soft nylon tube Within ± 0.1 mm
- Polyurethane tube Within +0.15mm, Within -0.2mm

Do not use tube which do not meet these outside diameter tolerances. It may not be possible to connect them, or they may cause other trouble, such as air leakage or the tube pulling out after connection.

5) **Do not apply unnecessary forces, such as twisting, pulling moment loads, vibration, impact, etc., on fittings or tubing.**

6) **Tube, with the exception of coiled tube, requires stationary installation. Do not use standard tube (non-coiled) in applications where tube is required to travel inside the flexible protection tube. Tubing that travels may sustain abrasion, extension, or severance due to tensile force. The removal of tube from the fitting may also occur. Use caution prior to use in an application.**

- Do not lift the product body with the tube after connecting the tube to the product. Otherwise, damage to the one-touch fittings may occur. For details, refer to the "Handling Precautions for SMC Products" on the SMC website: <https://www.smcworld.com>

7) **Adjust the length of air tubing following by the movement of the robot arm to avoid adding tension the tubing.**

When adding the tension of tubing repeatedly, it may result in air leakage.

And the tubing bending radius in the vicinity of the fitting should be at least the minimum bending radius of the tubing.

■ Exhaust from Ejector

- 1) If the operating environment contains a lot of particles or mist, the silencer may be clogged.

If the silencer is clogged, it will cause a reduction in the ejector performance. Replace the silencer in such case. (Refer to "7.1. Maintenance for vacuum gripper")

■ Exhaust noise

When vacuum ejector generates vacuum, noise can be heard from the exhaust port when the standard supply pressure is close to the pressure that generates peak vacuum pressure making vacuum pressure unstable. If the vacuum pressure range is adequate for gripping, there should not be a problem. If the noise causes a problem or affects the setting of the pressure sensor, change the supply pressure slightly to avoid the pressure range of the noise.

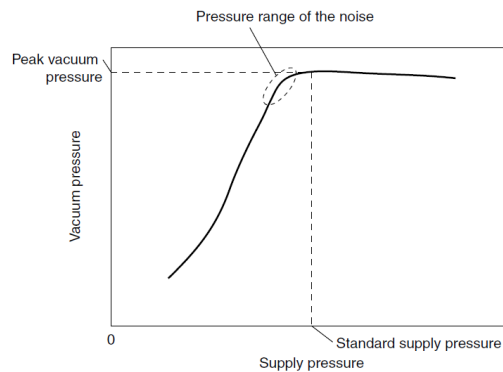

■ Workpiece

If water drops or dust are attached on the workpiece surface, they may go into the vacuum ejector and may cause the low vacuum performance. Also when workpieces are permeable, there is a case that sufficient lifting force cannot get. In such cases, it is necessary to perform a suction test to check the compatibility to your application before actual usage.

■ Field of view of the camera

⚠ Caution

Suction cups may interfere to the field of view of the camera, depending on the cup size or cup distance.

In case that the position detection of workpiece by using the camera module on the robot, the camera may not detect the workpiece correctly because of focusing to the suction cups. In such case, take measures such as to set the view of detection area of the camera which is not interfering the suction cups.

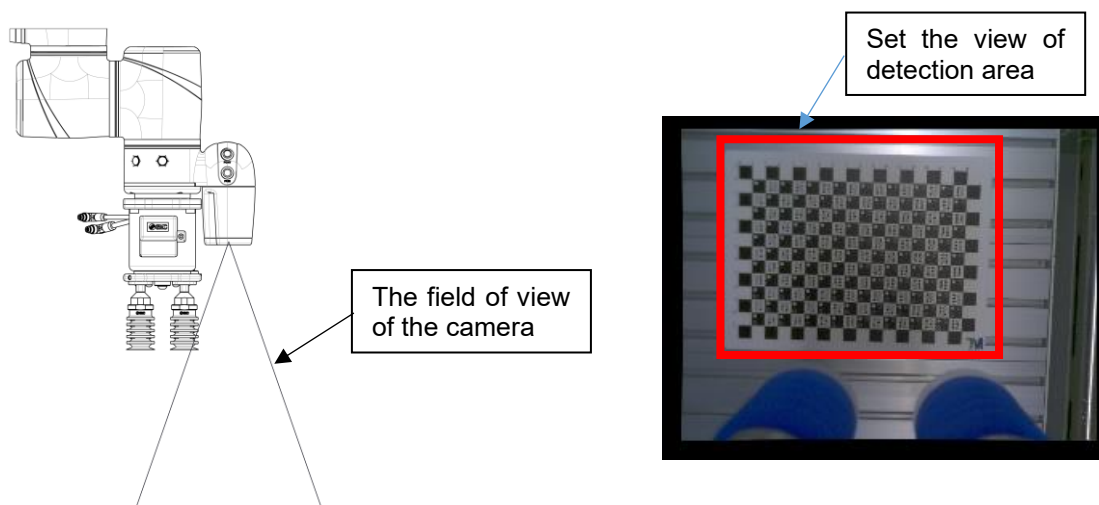

8.3 Suction cup precautions

■ Design

Warning

- 1) **In cases where the workpieces are heavy or dangerous objects, etc., take measures to address a possible loss of gripping force (installation of a drop prevention guide, etc.).**

In the case of transportation by vacuum gripping using suction cups, the gripping force is lost when there is a drop in vacuum pressure. Furthermore, since vacuum pressure can also deteriorate due to the wear and cracking of cups, vacuum leakage from piping, etc., be certain to perform maintenance on vacuum equipment.

■ Selection

Caution

- 1) **The cup materials which can be used differ depending upon the operating environment.**
An appropriate cup material should be selected. Furthermore, since suction cups are manufactured for use with industrial products, they should not come into direct contact with medicines, food products, etc.
- 2) **Depending upon the weight and shape of the workpieces, the diameter, quantity, and shape of cups suitable for use will vary.**

Refer to “3.3. How to calculate theoretical lifting force “ for the theoretical lifting force. Also, the selectable cups will differ based upon conditions other than the above, such as the condition of the workpiece surface (presence or absence of oil or water), the workpiece material, and its gas permeability. Confirmation is necessary by actually performing vacuum gripping on the subject workpieces.

- 3) **Do not apply an impact or large force to a cup when adsorbing a workpiece.**
This will cause the deformation, cracking, and wear of the cup to be accelerated. The stiffening ribs, etc., should touch lightly, while staying within the cup skirt's deformation range. Positioning should be performed accurately, especially in the case of small-diameter cups.
- 4) **When transporting vertically, factors such as acceleration, wind pressure, and impact force must be considered in addition to the workpiece weight.**
Use caution particularly when lifting items such as glass plates and circuit boards because a large force will be applied by wind pressure. When a workpiece which is oriented vertically is transported horizontally, large forces are applied by acceleration when movement is started and stopped. Furthermore, in cases where the cup and workpiece can slip easily, accelerations and decelerations of horizontal movement should be kept to a minimum.
- 5) **When transporting flat shaped workpieces that have large surface areas using multiple cups, care must be taken in arranging the cups, so that the workpieces are evenly gripped.**
- 6) **Use caution since the workpiece could rotate during transfer.**
Use of more than one cup for each workpiece is recommended.

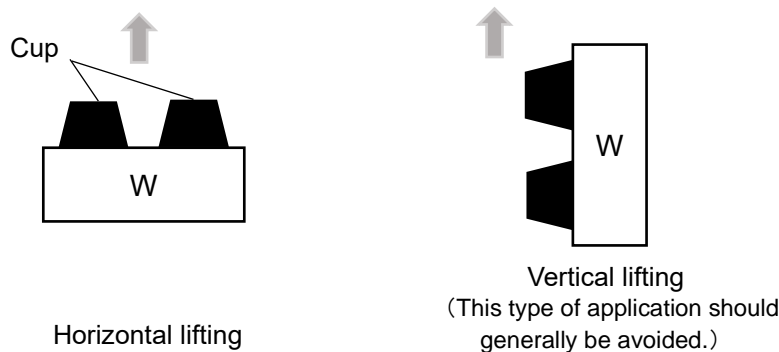

■ Gripping

This product has 4 pneumatically connected cups per ejector. If one cup fails to operate, all other cups cannot grip the object. Safety measures need to be taken to prevent falling of workpiece during transfer of the object. When gripping with cups which do not grip object is required, connect the vacuum saving valve, ZP2V series (Applicable model: ZP2V-B6-05). The valve suppresses the decrease of the vacuum pressure and there is a case that the workpiece can be held.

For the feasibility of workpiece and conditions of customer, operation check with the actual equipment is required.

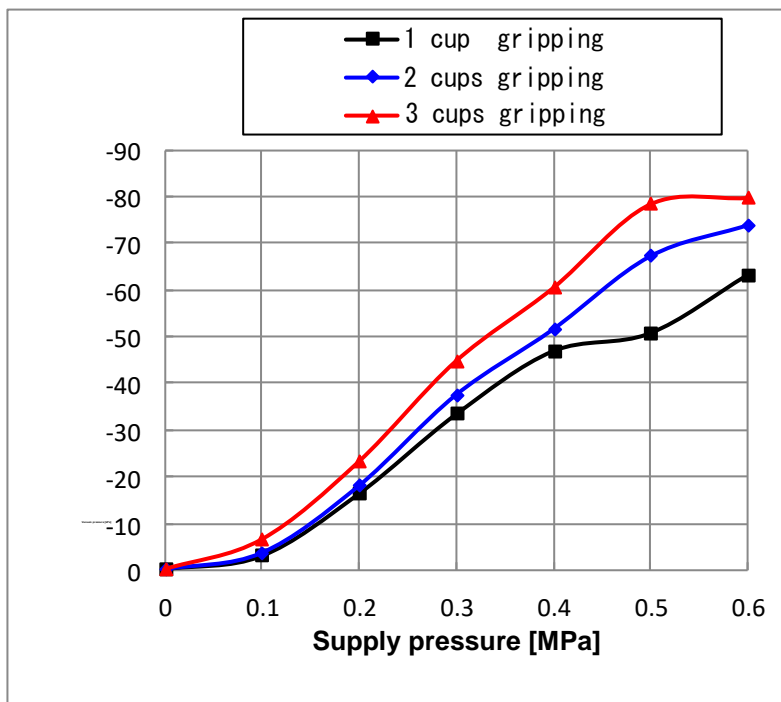
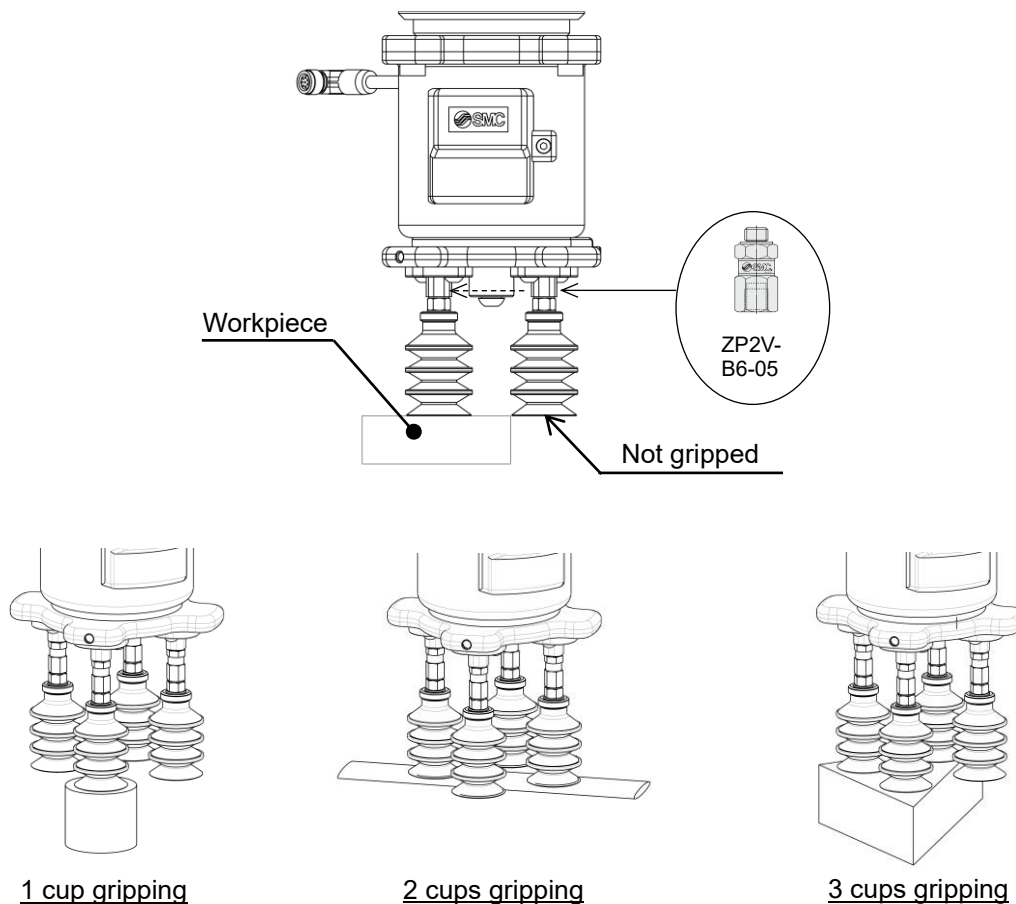

Exhaust Characteristics by using the vacuum saving valves: ZP2V-B06-05

* This data shows the data at the workpiece with no air leakage.

<Reference>

Theoretical lifting force of vacuum cup diameter 32mm with ZP2V-B06-05 at supply pressure 0.5 MPa

	Vacuum pressure [kPa]	Theoretical lifting force [N]	Horizontal lifting force [N] (Safety factor 1/4)
1 cup gripping	-50	40.2	10
2 cups gripping	-67	53.8	13.4
3 cups gripping	-73	58.7	14.6

(Calculated by "W = P X S, S = $\pi \cdot r^2$, r = $\Phi 32 / 2$ ". Refer to 3.3 How to calculate theoretical lifting force for the detail.)

■ Storage

 **Caution**

- 1) **It is recommended to store suction cups in the environment shown in the table below.**
Storing in an environment other than that recommended below may lead to changes in properties (deformation, discoloration, cracking, increased adhesiveness, etc.).

Recommended Storage Environment for Suction cups

Temperature	15 to 25[°C]
Humidity	50[%] or less, No condensation
Other	Location that is shaded from direct sunlight or fluorescent light Location without the presence of ozone (For NBR and conductive NBR)

9. Troubleshooting

Condition & Description of improvement	Contributing factor	Countermeasure
Initial a gripping problem (During trial operation)	Gripping area is small. (Lifting force is lower than the workpiece mass.)	Recheck the relationship between workpiece mass and lifting force. - Use a suction cup with a large gripping area. - Increase the quantity of suction cups.
	Vacuum pressure is low. (Leakage from gripping surface) (Air permeable workpiece)	Eliminate (reduce) leakage from gripping surface. - Reconsider the shape of a suction cup. Check the relationship between suction flow rate and arrival pressure of vacuum ejector. - Increase gripping area.
	Inadequate supply pressure of vacuum ejector	Measure supply pressure in vacuum generation state. - Use standard supply pressure. - Reconsider compressed air circuit (line).
	Clogging of vacuum ejector (Infiltration of contamination during piping)	Remove contamination. Product needs to be repaired. Flush and installation of air filter on inside in circuits for countermeasure.
	The pressure just before the supply (P) port is low.	Depending on the piping volume (piping length and diameter), if the pressure just before the supply (P) port falls below 0.5MPa, the performance such as vacuum pressure may reduce. - Raise the upstream pressure, and the pressure just before the supply (P) port becomes 0.5MPa.
Late vacuum achieving time (Shortening of response time)	The set vacuum pressure for the suction verification is too high.	Set to suitable setting pressure.
Fluctuation in vacuum pressure	Fluctuation in supply pressure	Reconsider compressed air circuit (line). (Addition of a tank etc.)
	Vacuum pressure may fluctuate under certain conditions due to ejector characteristics.	Lower or raise supply pressure a little at a time, and use in a supply pressure range where vacuum pressure does not fluctuate.
Occurrence of abnormal noise (intermittent noise) from exhaust of vacuum ejector	Intermittent noise may occur under certain conditions due to ejector characteristics.	Lower or raise supply pressure a little at a time, and use in a supply pressure range where the intermittent noise does not occur.
Gripping problem over time (Gripping is normal during trial operation.)	Clogging of the silencer	Replace the silencer. Add a filter to supply (compressed) air circuit.
	Clogging of the mesh	Clean the mesh periodically as necessary by washing, air blow and so on or replacing plate B. Refer to "7.2 Maintenance for suction cup".
	Presence of contamination in the ejector.	Remove contamination. Product needs to be repaired. Flush and installation of air filter on inside in circuits for countermeasure.
	Air leakage due to loosen the compressed air supply (P) port	If the fitting of the air supply (P) port is loose, tighten up it. Please refer to the catalog of one-touch fittings about tightening torque.
	Cup (rubber) deterioration, cracking, etc.	Replace cups. Check the compatibility of vacuum cup material and workpiece.
Workpiece is not released.	The increase of stickiness due to the wearing of the cup (rubber).	Replace cups. Check the compatibility of the cup material and workpiece.
	Vacuum pressure is too high.	Set the vacuum pressure to the minimum value necessary.

Revision history

Rev. A: Circuit modified. Appearance dimension change Add to Center of gravity Revise errors. Add to troubleshooting
Rev. B: Add caution and troubleshooting, apply for UKCA
Rev. C: Applicable suction cup with adapter and adapter unit part number changed
Rev. D: Safety Instructions correction Product specifications Pressure sensor error correction, notation correction

SMC Corporation

Tel: + 81 3 5207 8249 Fax: +81 3 5298 5362
URL <https://www.smcworld.com>

Note: Specifications are subject to change without prior notice and any obligation on the part of the manufacturer.
© SMC Corporation All Rights Reserved