



# Operation Manual

PRODUCT NAME

Digital Pressure Switch

MODEL / Series / Product Number

*ZSE10(F)*  
*ISE10*

**SMC Corporation**

## Table of Contents

Safety Instructions	3
Model Indication and How to order	10
Summary of Product parts	12
Definition and terminology	13
Mounting and Installation	16
Installation	16
Piping	18
Wiring	19
Internal circuit and wiring example	20
Pressure Setting	21
Measurement mode	21
Function Setting	23
Function selection mode	23
Default setting	23
F0 Units selection function	25
F1 Setting of OUT1	26
F2 Setting of OUT2	29
F3 Response time	31
F4 Auto-preset function	32
F6 Fine adjustment of display value	34
F11 Display resolution	35
F80 Power saving mode	36
F81 Security code	37
F90 Setting of all functions	38
F97 Copy function	40
F98 Check of output	42
F99 Reset to the default setting	44
Other Settings	45
Maintenance	48
If the security code is forgotten	48
Troubleshooting	49
Specifications	57
Dimensions	59



# Safety Instructions

These safety instructions are intended to prevent hazardous situations and/or equipment damage. These instructions indicate the level of potential hazard with the labels of “**Caution**,” “**Warning**” or “**Danger**.” They are all important notes for safety and must be followed in addition to International Standards (ISO/IEC)<sup>\*)</sup>, and other safety regulations.

\*1) ISO 4414: Pneumatic fluid power - General rules and safety requirements for systems and their components  
ISO 4413: Hydraulic fluid power - General rules and safety requirements for systems and their components  
IEC 60204-1: Safety of machinery - Electrical equipment of machines - Part 1: General requirements  
ISO 10218-1: Robots and robotic devices - Safety requirements for industrial robots - Part 1: Robots  
etc.



## **Danger**

**Danger** indicates a hazard with a high level of risk which, if not avoided, will result in death or serious injury.



## **Warning**

**Warning** indicates a hazard with a medium level of risk which, if not avoided, could result in death or serious injury.



## **Caution**

**Caution** indicates a hazard with a low level of risk which, if not avoided, could result in minor or moderate injury.

## **Warning**

### **1. The compatibility of the product is the responsibility of the person who designs the equipment or decides its specifications.**

Since the product specified here is used under various operating conditions, its compatibility with specific equipment must be decided by the person who designs the equipment or decides its specifications based on necessary analysis and test results. The expected performance and safety assurance of the equipment will be the responsibility of the person who has determined its compatibility with the product. This person should also continuously review all specifications of the product referring to its latest catalog information, with a view to giving due consideration to any possibility of equipment failure when configuring the equipment.

### **2. Only personnel with appropriate training should operate machinery and equipment.**

The product specified here may become unsafe if handled incorrectly. The assembly, operation and maintenance of machines or equipment including our products must be performed by an operator who is appropriately trained and experienced.

### **3. Do not service or attempt to remove product and machinery/equipment until safety is confirmed.**

1. The inspection and maintenance of machinery/equipment should only be performed after measures to prevent falling or runaway of the driven objects have been confirmed.
2. When the product is to be removed, confirm that the safety measures as mentioned above are implemented and the power from any appropriate source is cut, and read and understand the specific product precautions of all relevant products carefully.
3. Before machinery/equipment is restarted, take measures to prevent unexpected operation and malfunction.

### **4. Our products cannot be used beyond their specifications. Our products are not developed, designed, and manufactured to be used under the following conditions or environments. Use under such conditions or environments is not covered.**

1. Conditions and environments outside of the given specifications, or use outdoors or in a place exposed to direct sunlight.
2. Use for nuclear power, railways, aviation, space equipment, ships, vehicles, military application, equipment affecting human life, body, and property, fuel equipment, entertainment equipment, emergency shut-off circuits, press clutches, brake circuits, safety equipment, etc., and use for applications that do not conform to standard specifications such as catalogs and operation manuals.
3. Use for interlock circuits, except for use with double interlock such as installing a mechanical protection function in case of failure. Please periodically inspect the product to confirm that the product is operating properly.



# Safety Instructions

## Caution

**We develop, design, and manufacture our products to be used for automatic control equipment, and provide them for peaceful use in manufacturing industries.**

**Use in non-manufacturing industries is not covered.**

Products we manufacture and sell cannot be used for the purpose of transactions or certification specified in the Measurement Act.

The new Measurement Act prohibits use of any unit other than SI units in Japan.

## Limited warranty and Disclaimer/Compliance Requirements

The product used is subject to the following “Limited warranty and Disclaimer” and “Compliance Requirements”.

Read and accept them before using the product.

### Limited warranty and Disclaimer

1. The warranty period of the product is 1 year in service or 1.5 years after the product is delivered, whichever is first.\*2)

Also, the product may have specified durability, running distance or replacement parts. Please consult your nearest sales branch.

2. For any failure or damage reported within the warranty period which is clearly our responsibility, a replacement product or necessary parts will be provided.

This limited warranty applies only to our product independently, and not to any other damage incurred due to the failure of the product.

3. Prior to using SMC products, please read and understand the warranty terms and disclaimers noted in the specified catalog for the particular products.

**\*2) Vacuum pads are excluded from this 1 year warranty.**

A vacuum pad is a consumable part, so it is warranted for a year after it is delivered.

Also, even within the warranty period, the wear of a product due to the use of the vacuum pad or failure due to the deterioration of rubber material are not covered by the limited warranty

### Compliance Requirements

1. The use of SMC products with production equipment for the manufacture of weapons of mass destruction (WMD) or any other weapon is strictly prohibited.

2. The exports of SMC products or technology from one country to another are governed by the relevant security laws and regulations of the countries involved in the transaction. Prior to the shipment of a SMC product to another country, assure that all local rules governing that export are known and followed.

## Operator

- ◆ This operation manual is intended for those who have knowledge of machinery using pneumatic equipment, and have sufficient knowledge of assembly, operation and maintenance of such equipment. Only those persons are allowed to perform assembly, operation and maintenance.
- ◆ Read and understand this operation manual carefully before assembling, operating or providing maintenance to the product.

### ■ Safety Instructions

#### **Warning**

- Do not disassemble, modify (including changing the printed circuit board) or repair.  
An injury or failure can result.
- Do not operate the product outside of the specifications.  
Do not use for flammable or harmful fluids.  
Fire, malfunction, or damage to the product can result.  
Verify the specifications before use.
- Do not operate in an atmosphere containing flammable or explosive gases.  
Fire or an explosion can result.  
This product is not designed to be explosion proof.
- Do not use the product in a place where static electricity is a problem.  
Otherwise it can cause failure or malfunction of the system.
- If using the product in an interlocking circuit:
  - Provide a double interlocking system, for example a mechanical system
  - Check the product regularly for proper operationOtherwise malfunction can result, causing an accident.
- The following instructions must be followed during maintenance:
  - Turn off the power supply
  - Stop the air supply, exhaust the residual pressure and verify that the air is released before performing maintenanceOtherwise an injury can result.

## Caution

- Do not touch the terminals and connectors while the power is on.  
Otherwise electric shock, malfunction or damage to the product can result.
- After maintenance is complete, perform appropriate functional inspections and leak tests.  
Stop operation if the equipment does not function properly or there is a leakage of fluid.  
When leakage occurs from parts other than the piping, the product might be faulty.  
Disconnect the power supply and stop the fluid supply.  
Do not apply fluid under leaking conditions.  
Safety cannot be assured in the case of unexpected malfunction.

## ■ NOTE

- Follow the instructions given below when designing, selecting and handling the product.
  - The instructions on design and selection (installation, wiring, environment, adjustment, operation, maintenance, etc.) described below must also be followed.
    - \*Product specifications
      - The direct current power supply to be used should be UL approved as follows.  
Circuit (of Class2) which is of maximum 30 Vrms (42.4 V peak) or less, with UL1310 Class2 power supply unit or UL1585 Class2 transformer.
      - The Pressure switch is a UL approved product only if it has a  mark on the body.
      - Use the specified voltage.  
Otherwise failure or malfunction can result.
      - Do not exceed the specified maximum allowable load.  
Otherwise it can cause damage or shorten the lifetime of the Pressure switch.
      - Design the product to prevent reverse current when the circuit is opened or the product is forced to operate for operational check.  
Reverse current can cause malfunction or damage to the product.
      - Input data to the Pressure switch is not deleted, even if the power supply is cut off.  
(Writing time: 1,000,000 times, Data duration: 10 years after power off)
      - Use the clean air  
This can cause operating failure.  
If compressed air containing condensate is used, install an air dryer or drain catch before the filter and perform drainage regularly.  
If drainage is not performed regularly and condensate enters the secondary side, it can cause operating failure of pneumatic equipment.  
If regular drainage is difficult, the use of a filter with an auto drain is recommended.
      - Applicable fluid is air, inert gases and incombustible gases.  
Do not use a fluid containing chemicals, synthetic oils including organic solvent, salt and corrosive gases.  
Otherwise, damage to the product and malfunction can result.  
Check the details of the specifications before using.
      - Use the specified operating pressure.  
Otherwise it can cause damage to the Pressure switch or inability to measure correctly.
      - Reserve a space for maintenance.  
Allow sufficient space for maintenance when designing the system.

## ●Product handling

### \*Installation

- Tighten to the specified tightening torque.

If the tightening torque is exceeded the mounting screws and brackets may be broken.

If the tightening torque is insufficient, the product can be displaced and loosen the mounting screws.

(Refer to "Mounting and Installation" on page 16.)

- Do not apply excessive stress to the product when it is mounted with a panel mount.

Otherwise damage to the product and disconnection from the panel mount can result.

- Be sure to ground terminal FG when using a commercially available switch-mode power supply.

- Do not drop, hit or apply shock to the Pressure switch.

Otherwise damage to the internal parts can result, causing malfunction.

- Do not pull the lead wire forcefully, not lift the product by pulling the lead wire. (Tensile force 35 N or less)

Hold the body when handling to avoid the damage of the Pressure switch which lead to cause the failure and malfunction.

- For piping of the Pressure switch, hold the piping with a spanner on the metal part of the piping (Piping attachment).

Holding other part with spanner leads to damage the Pressure switch.

- The tightening torque of piping must be 1 N•m for M5 (This is equivalent to approximate 1/6 extra tightening after manual tightening.) and 7 to 9 N•m for R1/8 and NPT1/8.

Exceeding this value can damage the piping.

- For piping of the Pressure switch, hold the piping with a spanner on the metal part of the piping (Piping attachment).

Holding other part with spanner leads to damage the Pressure switch.

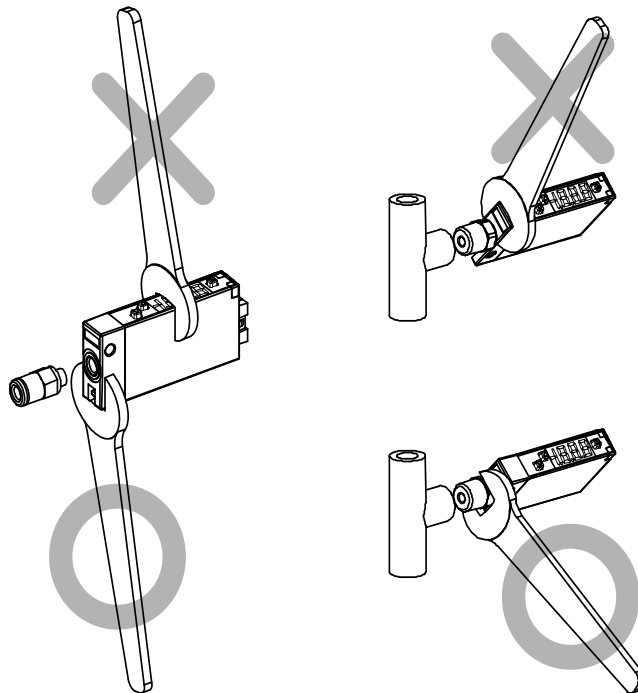

M5 female thresd type

R1/8, NPT1/8 type

- Eliminate any dust left in the piping by air blow before connecting the piping to the product.

Otherwise it can cause damage or malfunction.

- Do not insert metal wires or other foreign matter into the pressure measurement port.

It can damage the pressure sensor causing failure or malfunction.

- Never mount a Pressure switch in a location that will be used as a foothold.  
The product may be damaged if excessive force is applied by stepping or climbing onto it.
- If the entering of foreign material to the fluid is possible, install and pipe the filter or the mist separator to the inlet to avoid failure and malfunction.

#### \*Wiring

- Do not pull the lead wires.  
In particular, never lift a Pressure switch equipped with fitting and piping by holding the lead wires.  
Otherwise damage to the internal parts can result, causing malfunction or to be off the connector.
- Avoid repeatedly bending or stretching the lead wire, or placing heavy load on them.  
Repetitive bending stress or tensile stress can cause the sheath of the wire to peel off, or breakage of the wire.  
If the lead wire can move, fix it near the body of the product.  
The recommended bend radius of the lead wire is 6 times the outside diameter of the sheath, or 33 times the outside diameter of the insulation material, whichever is larger.  
Replace the damaged lead wire with a new one.
- Wire correctly.  
Incorrect wiring can break the Pressure switch.
- Do not perform wiring while the power is on.  
Otherwise damage to the internal parts can result, causing malfunction.
- Do not route wires and cables together with power or high voltage cables.  
Otherwise the product can malfunction due to interference of noise and surge voltage from power and high voltage cables to the signal line. Route the wires (piping) of the product separately from power or high voltage cables.
- Confirm proper insulation of wiring.  
Poor insulation (interference from another circuit, poor insulation between terminals, etc.) can lead to excess voltage or current being applied to the product, causing damage.
- Design the system to prevent reverse current when the product is forced to operate for operational check.  
Depending on the circuit used, insulation may not be maintained when operation is forced, allowing reverse current to flow, which can cause malfunction and damage the product.
- Keep wiring as short as possible to prevent interference from electromagnetic noise and surge voltage.  
Do not use a cable longer than 30 m.  
Wire the DC(-) line(blue) as close as possible to the power supply.
- When analogue output is used, install a noise filter (line noise filter, ferrite element, etc.) between the switch-mode power supply and this product.

#### \*Environment

- Do not use the product in area that is exposed to corrosive gases, chemicals, sea water, water or steam.  
Otherwise failure or malfunction can result.
- Do not use in a place where the product could be splashed by oil or chemicals.  
If the product is to be used in an environment containing oils or chemicals such as coolant or cleaning solvent, even for a short time, it may be adversely affected (damage, malfunction, or hardening of the lead wires).
- Do not use in an area where surges are generated.  
If there is equipment which generates a large amount of surge (solenoid type lifter, high frequency induction furnace, motor, etc.) close to the Pressure switch, this may cause deterioration or breakage of the internal circuit of the Pressure switch. Avoid sources of surge generation and crossed lines.
- Do not use a load which generates surge voltage.  
When a surge-generating load such as a relay or solenoid is driven directly, use a Pressure switch with a built-in surge absorbing element.
- The product is CE marked, but not immune to lightning strikes. Take measures against lightning strikes in the system.  
This product is CE marked, it may happen that the set value of product is changed by the noise impressed in excess.
- Mount the product in a place that is not exposed to vibration or impact.  
Otherwise failure or malfunction can result.



- Prevent foreign matter such as remnant of wires from entering the Pressure switch.  
Take proper measures for the remnant not to enter the Pressure switch in order to prevent failure or malfunction.
- Do not use the product in an environment that is exposed to temperature cycle.  
Heat cycles other than ordinary changes in temperature can adversely affect the inside of the product.
- Do not expose the product to direct sunlight.  
If using in a location directly exposed to sunlight, shade the product from the sunlight.  
Otherwise failure or malfunction can result.
- Keep within the specified fluid and ambient temperatures range.  
The fluid and ambient temperatures should be -5 to 50 °C. Operation under low temperature (5 °C or less) leads to cause damage or operation failure due to frozen moist in the fluid or air.  
Protection against freezing is necessary. Air dryer is recommended for elimination of drain and water.  
Avoid sudden temperature change even within specified temperature.
- Do not operate close to a heat source, or in a location exposed to radiant heat.  
Otherwise malfunction can result.

#### \*Adjustment and Operation

- Turn the power on after connecting a load.  
Otherwise it can cause excess current causing instantaneous breakage of the Pressure switch.
- Do not short-circuit the load.  
Although error is displayed when the Pressure switch load is short circuit, generated excess current lead to cause the damage of the Pressure switch.
- Do not press the setting buttons with a sharp pointed object.  
It may damage the setting buttons.
- If using the product to detect very small pressure rates, warm up the product for 10 to 15 minutes first.  
There will be a drift on the display and the analogue output of approximate 1% immediately after the power supply is turned on within 10 minutes.
- Perform settings suitable for the operating conditions.  
Incorrect setting can cause operation failure.  
For details of each setting, refer to page 21 to 47 of this manual.
- Do not touch the LED during operation.  
The display can vary due to static electricity.

#### \*Maintenance

- Turn off the power supply, stop the supplied air, exhaust the residual pressure and verify the release of air before performing maintenance.  
There is a risk of unexpected malfunction.
- Perform regular maintenance and inspections.  
There is a risk of unexpected malfunction.
- Perform drainage regularly.  
If condensate enters the secondary side, it can cause operating failure of pneumatic equipment.
- Do not use solvents such as benzene, thinner etc. to clean the Pressure switch.  
They could damage the surface of the body and erase the markings on the body.  
Use a soft cloth to remove stains. For heavy stains, use a cloth soaked with diluted neutral detergent and fully squeezed, then wipe up the stains again with a dry cloth.

# Model Indication and How to order

**ISE10** - **M5** - **A** -            

Set pressure range

	Symbol	Content
Positive pressure	ISE10	-0.1 to 1 MPa
Vacuum pressure	ZSE10	0 to -101 kPa
Compound pressure	ZSE10F	-100 to 100 kPa

Piping specification

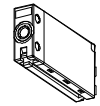
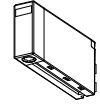
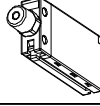
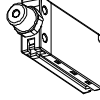
Symbol	Content	
M5	M5 female thread Side piping <sup>*1</sup>	
M5R	M5 female thread Rear piping <sup>*1</sup>	
*01	R1/8 Side piping <sup>*2</sup>	
*N01	NPT1/8 Side piping <sup>*2</sup>	

- \*: Made to Order
- \*1: When using the tight mounting or direct mounting, select an appropriate fitting while referring to the dimensions.
- \*2: For piping specifications 01 and N01, the tight mounting or direct mounting cannot be made since the fitting interferes with the piping.

Output specification

Symbol	Content
A	NPN open collector 2 outputs
B	PNP open collector 2 outputs
*C	NPN open collector 1 output + Analog voltage output
*E	PNP open collector 1 output + Analog voltage output

\*: Made to Order

Option 3

Symbol	Calibration certificate
Nil	-
K	○

Option 2

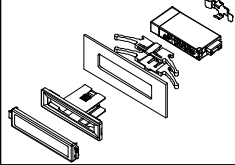
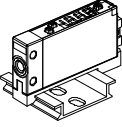
Symbol	Content	
Nil	No option	
D <sup>*3</sup>	Panel mount adapter + Front protective cover	
R <sup>*4</sup>	DIN rail mounting bracket <sup>*5</sup>	

- \*3: This option cannot be selected for the piping specification of 01 and N01.
- \*4: This option cannot be selected for the piping specification of M5R, 01 and N01.
- \*5: The DIN rail must be prepared by the customer.

Option 1

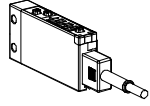
Symbol	Content	
Nil	Without lead wire	
G	With connector attached wire (lead wire 2 m, Equipped with 5 cores) and connector cover	

Unit specification

Symbol	Content
Nil	With unit conversion function <sup>*1</sup>
M	Fixed SI unit <sup>*2</sup>
*P	With unit conversion function (psi initial value) <sup>*1</sup>

\*1: The new Measurement Law prohibits the use of pressure switch with the unit conversion function in Japan.

A unit label is attached.

\*2: Fixed unit kPa, MPa

○Accessories / Part numbers

If an accessory is required independently, order with the following part number.

Description	Part number	Remarks
Panel mount adapter	ZS-39-B	-
Panel mount adapter + Front protective cover	ZS-39-D	-
Front protective cover	ZS-39-01	-
Lead wire with connector + connector cover	ZS-39-5G	5 cores, 2 m
R1/8 conversion adapter	ZS-39-N1 *	-
NPT1/8 conversion adapter	ZS-39-N2 *	-
DIN rail mounting adapter	ZS-39-R	-

\*: Made to Order

## Summary of Product parts

### Names of individual parts

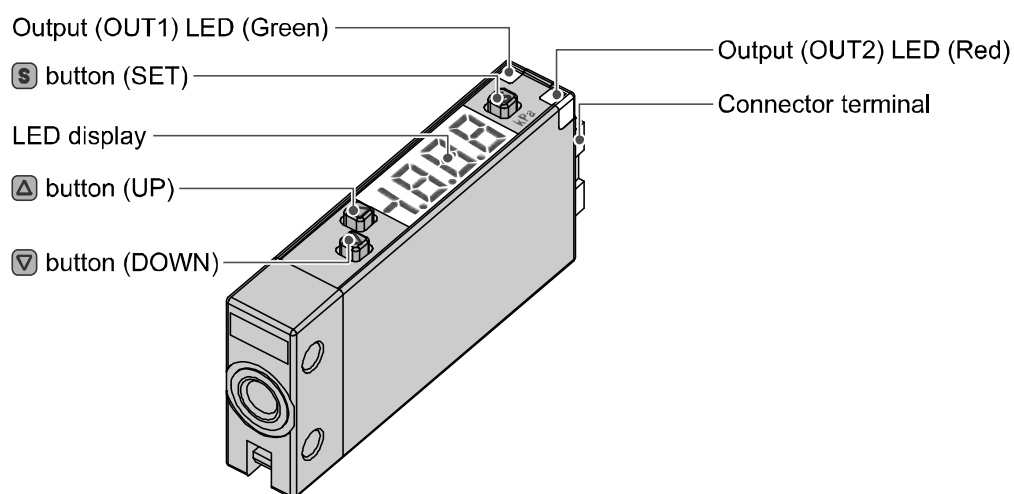

Output (OUT1) LED (Green): LED is ON when the switch output (OUT1) is ON.

Output (OUT2) LED (Red): Led is ON when the switch output (OUT2) is ON.

LED display: Displays the current status of pressure, setting mode and error code.

**▲** button (UP): Selects the mode or increases the ON/OFF set value.  
Press this button to change to the peak display mode.

**▼** button (DOWN): Selects the mode or decreases the ON/OFF set value.  
Press this button to change to the bottom display mode.

**S** button (SET): Press this button to change to another mode and to set a value.

## ■ Definition and terminology

	Terms	Meaning
7	7-segment display	When "8" is shown on the display. It is called 7-segment because 8 consists of 7 pieces of "-" (segments)".
A	Analogue output function	A function to output the voltage in proportion to the pressure.
	(Analogue) voltage output	Refer to "Analogue output function".
	Auto preset	A function to automatically set up the pressure by having equipment hold and release a workpiece via vacuum adsorption. This function is used in an application where vacuum adsorption of a workpiece is confirmed by a Pressure switch.
B	Bottom value display	Indicates the minimum pressure reached up to that moment.
C	Chattering	The problem of the switch output turning ON and OFF repeatedly around the set value at high frequency due to the effect of pulsation.
	Chattering preventing function	A function to delay the response time of switch output in order to prevent chattering.
	Copy destination Pressure switch	A Pressure switch whose settings are copied to when using the copy function.
	Copy function	A function to copy a pressure setting value and function setting (excluding fine adjustment of display value).
	Copy source Pressure switch	A Pressure switch whose settings are copied when using the copy function.
D	Digit (Minimum setting unit)	Shows how precisely the pressure can be displayed or set by the digital Pressure switch. When 1 digit=1 kPa, the pressure is given with an increment of 1kPa, e.g., 1, 2, 3, ..., 99, 100.
E	Error indication	With the self-diagnostic function of the Pressure switch, this indicates that there is an error which could cause a switch failure.
F	Fine adjustment mode	Refer to "Fine adjustment of display value".
	Fine adjustment of display value	A displayed pressure value can be adjusted within the range of $\pm 5\%$ R.D. ( $\pm 5\%$ of the displayed value). It is used if a true pressure value is known or to correct the difference of a displayed value of the measurement equipment nearby which measures the same pressure.
	F.S. (full span/full scale)	Abbreviation for full span or full scale; this means the maximum fluctuation range of the Pressure switch rated value. For example, when the output voltage is 1 to 5[V], the F.S. will be $5-1=4$ [V]. (Ref: $1\%F.S.=4 \times 0.01=0.04$ [V])
	Function selection mode	This is a mode in which each function is set up, and is a separate menu from the pressure setup. If the setting needs to be changed, "F*", each item can be set up. The items to be set up are: display colour, operation mode, output type, response time, display resolution, fine adjustment of display value, auto preset, power-saving mode and security code number.
H	Hysteresis	The difference between the pressure switch ON and OFF points, used to prevent chattering
	Hysteresis mode	Refer to "List of output modes" on page 28.

	Terms	Meaning
I	Indication accuracy	The deviation between displayed pressure value and the true pressure.
	Insulation resistance	Insulation resistance of the product itself. The resistance between an electrical circuit and the pressure switch body.
	Indication resolution	How fine the rated pressure range can be displayed (example: If a product for 0 to 1 MPa can display pressure by 0.001 MPa, the display resolution is 1/1000.)
	Indicator LED	The LED that turns on when the switch output is on.
	Indication unit	The unit of pressure used on the display.
K	Key lock function	A function that locks the setting buttons so that no accidental setting changes can be made.
M	Manual setup	Manual pressure set up without using auto preset. This term is used to distinguish from the pressure set up using auto preset.
	Max. applied voltage	The maximum value of applied voltage available to the output wire of the NPN output.
	Max. load current	The maximum current available to the output wire of the switch output.
	Max. (Min) load impedance	The maximum (minimum) load (resistance value and impedance) which can be connected to the output (output wire) of the analogue current output.
	Measurement mode	The condition in which the pressure is detected and displayed and the switch output is operating.
	Min. setting unit	Refer to "digit".
N	Normal output	The switch output operation in which the switch is turned on when pressure equal to or greater than the set value is detected. In the (hysteresis mode) window comparator mode, it is the operation in which the switch is turned on when pressure is within the switch output range (P1L to P1H or P2L to P2H). (Refer to "List of output modes" on page 28.)
	NPN (open collector) output	The switch output which uses the NPN transistor for output.
O	Operating mode	There are two choices, hysteresis mode and window comparator mode.
	Output impedance	The resistance value of a component between the voltage output element and the analogue voltage output. It is indicated as a resistance value which is converted in accordance with the condition in which resistance is directly connected to the voltage output element. There may be an error in the output voltage depending on this output impedance and the input impedance of customers' equipment. (example: If the Pressure switch with output impedance of 1kΩ is connected to the A/D converter to detect the analogue output of 5V, the detected voltage by the A/D converter becomes $5(V) \times 1(M\Omega)/(1(k\Omega) + 1(M\Omega)) \doteq 4.995(V)$ , and there is an error of approximate 0.005 V).
	Output type	The operation type of the switch output. Either normal output or reversed output can be selected. (Refer to "List of output modes" on page 28.)
P	Peak value display	Displays the maximum pressure reached up to that moment.
	Piping-port size	The size of the port on the switch body with which a device can be connected
	PNP (open collector) output	The switch output that uses the PNP transistor for output.
	Power saving mode	The condition in which the display is turned off to reduce current consumption
	Pressure-sensing part	The pressure-detecting part of a pressure-detecting element.
	Pressure setting	The setting of pressure to determine the point at which the Pressure switch turns on and off.
	Proof pressure	The pressure beyond which the Pressure switch will be damaged.

	Terms	Meaning
R	Rated pressure range	The pressure range in which the Pressure switch meets the specifications. Values outside of this range can be set if they are within the set pressure range, but cannot be guaranteed to meet the product specifications.
	Repeatability	Reproducibility of the displayed value for pressure and ON-OFF output operating point when the pressure changes.
	Residual voltage	The difference between the ideal ON voltage and the actual voltage when the switch output is on. It depends on present load current and ideally should be "0".
	Resolution	Refer to "Indication resolution".
	Response time	The elapsed time until the ON-OFF output begins operating, since the pressure supplied to the Pressure switch has reached the set value. Generally, the shorter the response time, the better the performance.
	Reversed output	The switch output operation in which the switch is turned on when pressure equal to or less than the set value is detected. In the (hysteresis mode) window comparator mode, it indicates the operation in which a switch is turned on when pressure is outside the switch output range (n1L to n1H or n2L to n2H). (Refer to "List of output modes" on page 28.)
	Ripple	A type of chattering.
S	Setting of function	Refer to "Function selection mode".
	Setting pressure range	The pressure range within which the switch output can be set.
	Switch output	Alternatively called "ON-OFF output".
U	Units selection function	Function to change the unit in which the value of pressure is displayed. Only a product with this function can change the unit. A product with Units selection function cannot be purchased if it is used within Japan. Pressure is indicated only by SI units in Japan.
W	Wetted part (or part exposed to fluid)	The part of the Pressure switch which is in contact with the detected fluid, such as a pressure sensor, seal, or fitting.
	Window comparator mode	An output type which holds the output when the pressure is within a certain range. (Refer to "List of output modes" on page 28.)
	Withstand voltage	The ability to withstand a voltage applied between an electrical circuit and the body. If more voltage is applied to the product, the product may be damaged. (voltage mentioned here is not power voltage to activate the product).
Z	Zero clear function	The function which can adjust the displayed pressure value to "0".

# Mounting and Installation

## ■ Installation

### ○ Mounting

\*: The required tightening torque of the piping port is 1 N•m for M5 (This is equivalent to approximately 1/6 extra tightening after manual tightening) and 7 to 9 N•m for R1/8 and NPT1/8.

- Mount with the set screws M3 size (2 pcs.) supplied for direct installation.  
The required tightening torque of the mounting screws is 0.5 to 0.7 N•m.

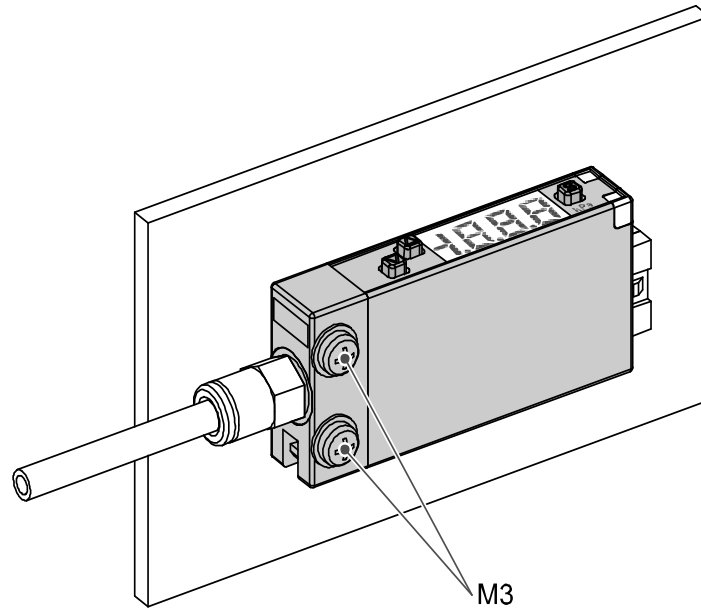

### ○ Mounting with panel mount adapter

- Panel mount adapter + Front protective cover (Model: ZS-39-D)

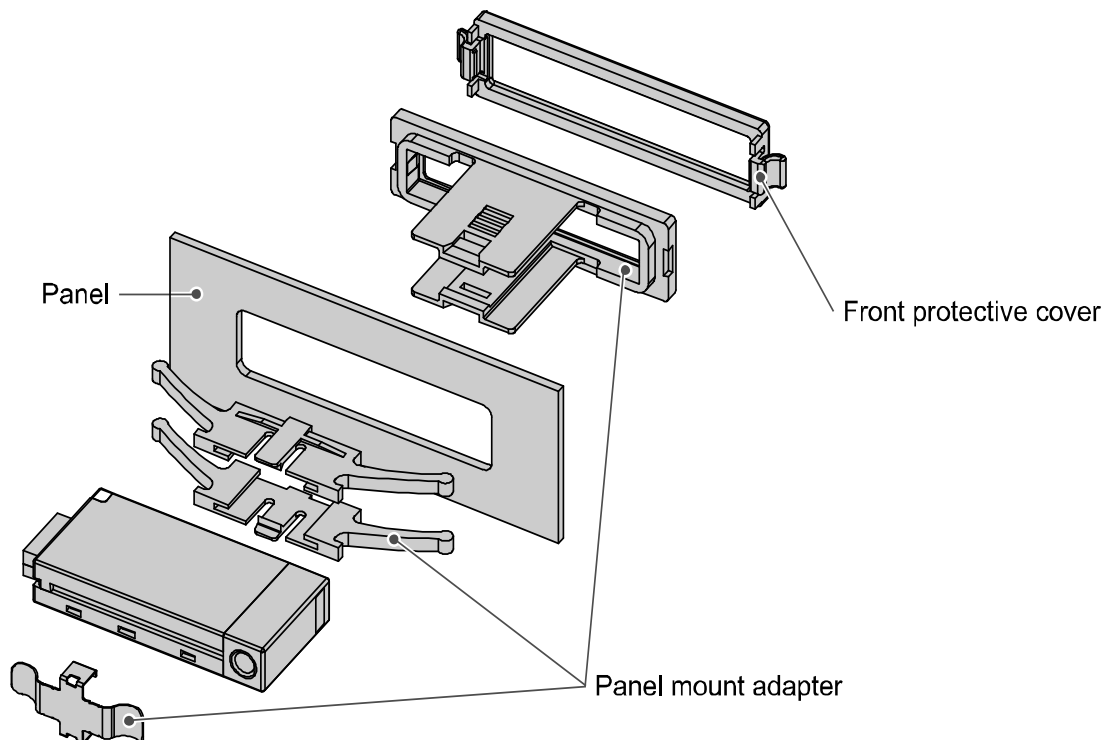



○Removal and mounting on DIN rail

- It is necessary to prepare a DIN rail adapter for the mounting on the DIN rail. (Model: ZS-39-R)
- Take care not to bend the claws of the DIN rail adapter when mounting.

<Mounting on DIN rail adapter>

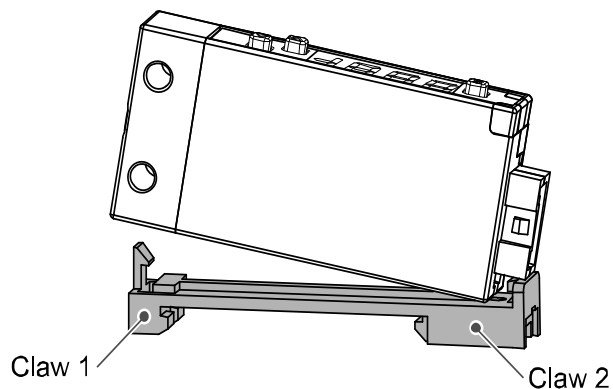

Engage the Pressure switch with claw 2 of the DIN rail adapter, then press down on to claw 1 until it clicks.

<Mounting on DIN rail>

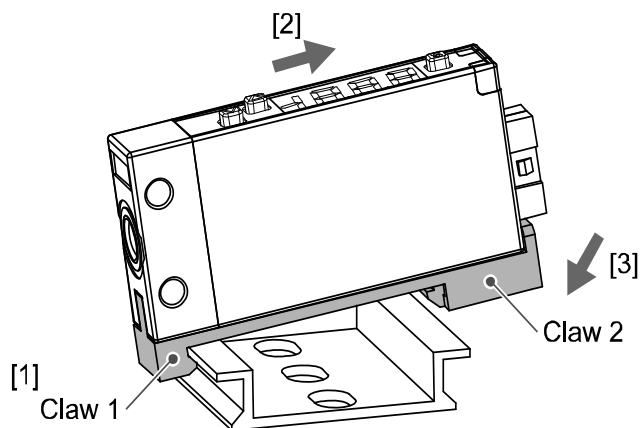

Engage claw 1 of the adapter on to the DIN rail as shown [1], apply force in direction [2], then press downward [3] until claw 2 clicks on to the DIN rail.

<Removal from DIN rail>

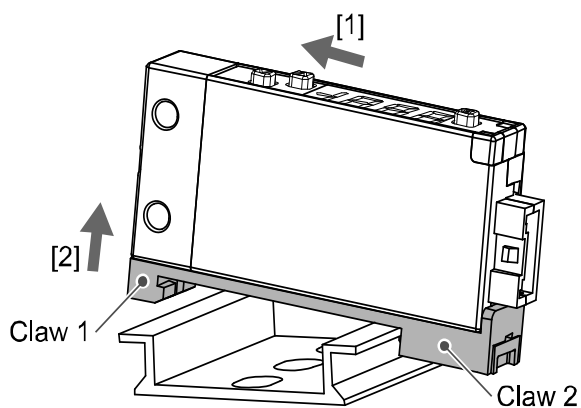

Move in the direction [1], and remove claw 1 in direction [2] as shown.

## ■Piping

### ○Connection using One-touch fitting

1. Cut the tube end perpendicular.
2. Hold the tube and insert it into the One-touch fitting slowly until it bottoms out.

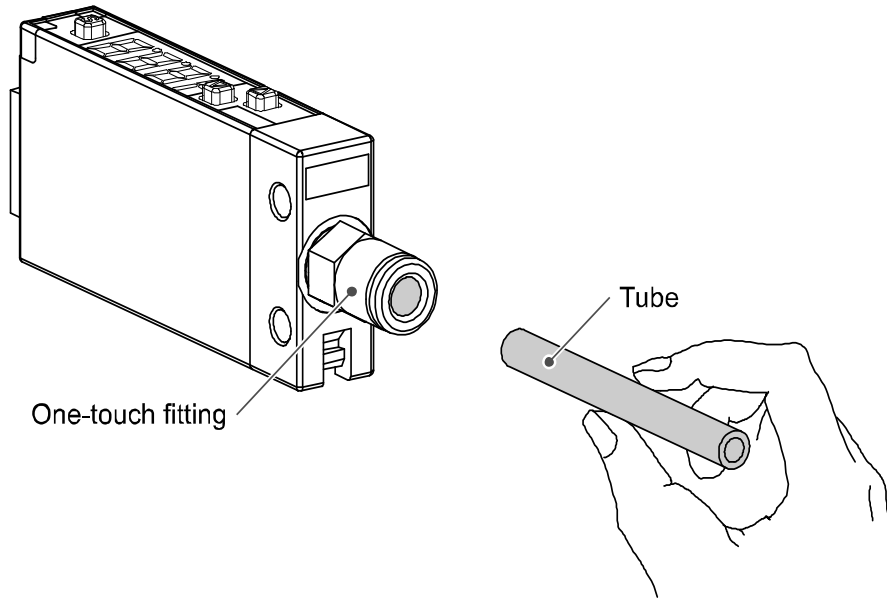

## ⚠ Warning

- Do not use the Pressure switch in a place where electrical static charge will be a problem. It can cause an error and damage to the system.

- Allow sufficient tube length to prevent twist and tensile or moment loads from being applied to the fitting or tube.
- When using a tube manufactured by a company other than SMC, check that its outside diameter tolerance satisfies the following values:
  - 1) Nylon tube:  $\pm 0.1$  mm maximum
  - 2) Soft nylon tube:  $\pm 0.1$  mm maximum
  - 3) Polyurethane tube:  $+0.15$  mm/ $-2$  mm maximum

## ■Wiring

### ○Connection

- Connections should only be made with the power supply turned off.
- Use separate routes for the Pressure switch wiring and any power or high voltage wiring. Otherwise, malfunction may result due to noise.
- Ensure that the FG terminal is connected to ground when using a commercially available switch-mode power supply. When a switch-mode power supply is connected to the product, switching noise will be superimposed and the product specification can no longer be met. This can be prevented by inserting a noise filter, such as a line noise filter and ferrite core, between the switch-mode power supply and the product, or by using a series power supply instead of a switch-mode power supply.

### ○Connector

#### Connecting/Disconnecting

- When mounting the connector, insert it straight into the socket, holding the lever and connector body, and push the connector until the lever hooks into the housing, and locks.
- When removing the connector, press down the lever to release the hook from the housing and pull the connector straight out.

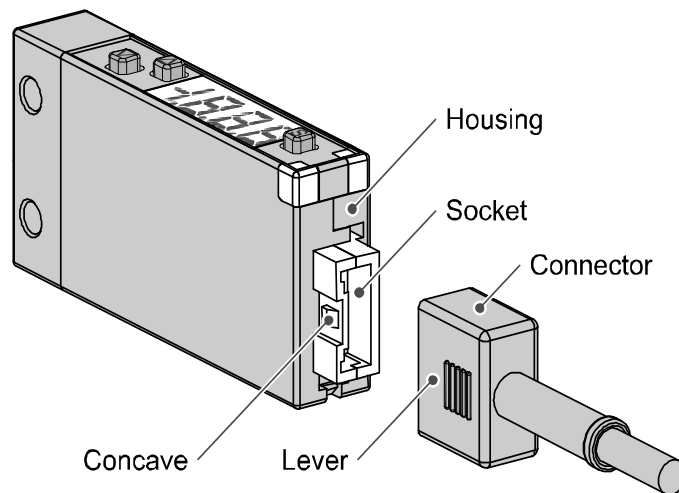

#### Connector pin numbers

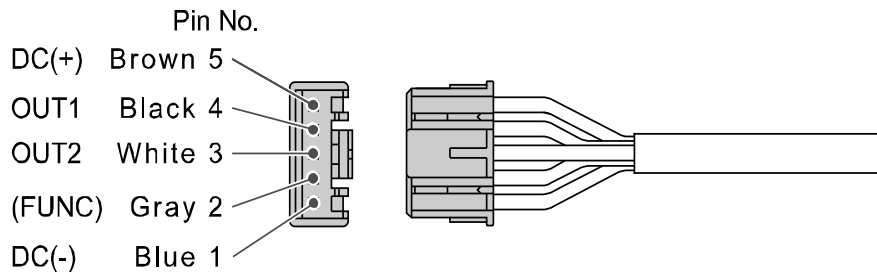

■ Internal circuit and wiring example

Z/ISE10(F)-□-□-□□□□

● Output specification

- A NPN open collector 2 outputs  
Max. 28 V, 80 mA  
Residual voltage 2 V or less

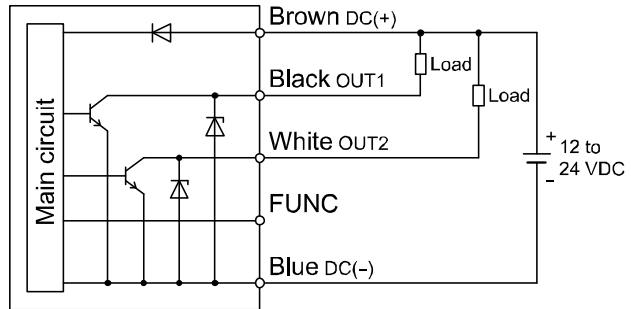

- B PNP open collector 2 outputs  
Max. 80 mA  
Residual voltage 2 V or less

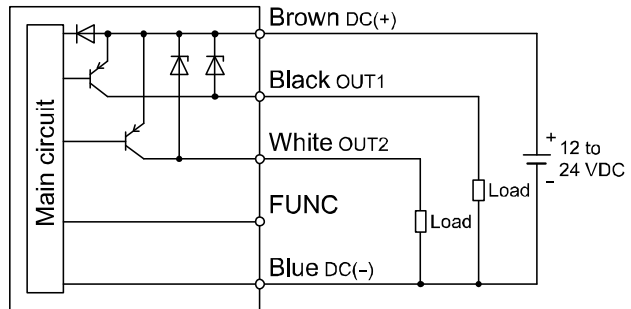

- C NPN open collector 1 output  
Max. 28 V, 80 mA  
Residual voltage 2 V or less  
Analogue voltage output  
Output impedance approx. 1 kΩ

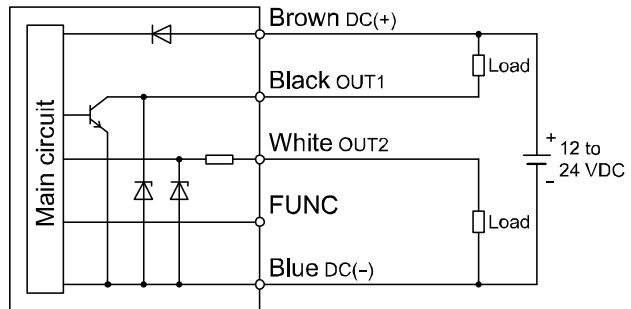

- E PNP open collector 1 output  
Max. 80 mA  
Residual voltage 2 V or less  
Analogue voltage output  
Output impedance approx. 1 kΩ

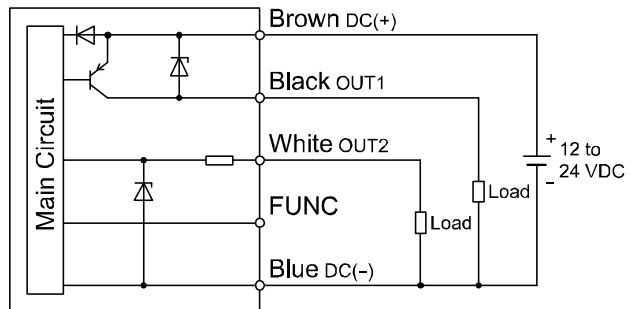

# Pressure Setting

## ■ Measurement mode

The measurement mode is the condition where the pressure is detected and displayed, and the switch function is operating.

This is the basic mode, and other modes should be selected for setting changes and other function settings.

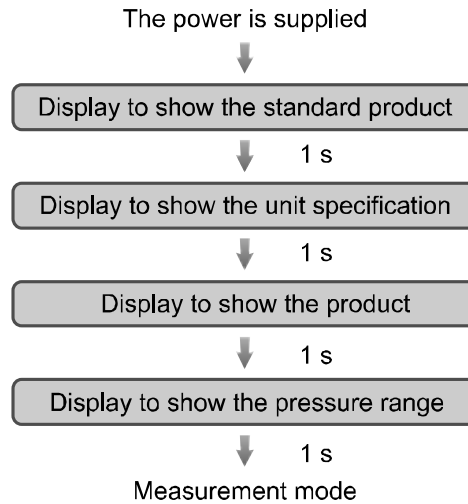

Setting the ON and OFF points of the Pressure switch.

### Operation

When the pressure exceeds a set value, the Pressure switch will be turned ON.

When the pressure falls below the set value by the amount of hysteresis or more, the Pressure switch will be turned OFF.

The default setting of the output set value is the central value between the atmospheric pressure and the upper limit of the rated pressure range.

If this condition, shown below, is acceptable, then keep these settings.

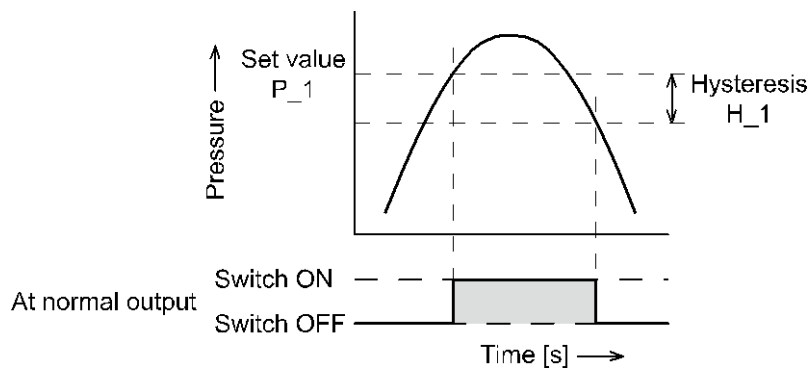

## <Operation>

[Hysteresis mode]

- 1, Press the **S** button once in measurement mode.



- 2, [P\_1] or [n\_1] and the set value are displayed in turn.

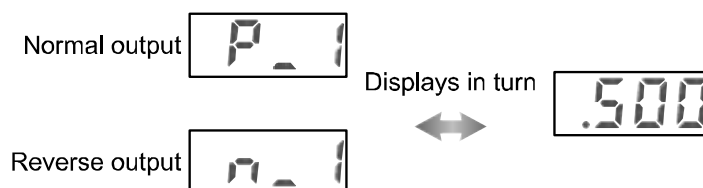

- 3, Press the **▲** or **▼** button to change the set value.  
The **▲** button is to increase and the **▼** button is to decrease.

- Press the **▲** button once to increase by one digit, and press it continuously to keep increasing the set value.

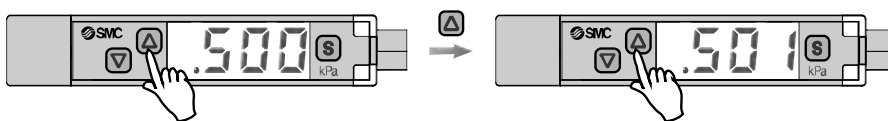

- Press the **▼** button once to decrease by one digit, and press it continuously to keep decreasing the set value.

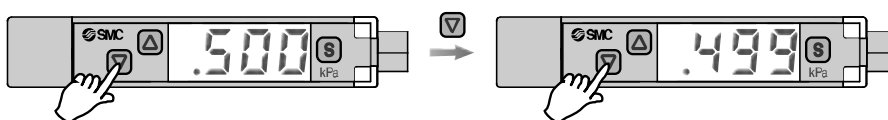

- 4, Press the **S** button to finish the setting.  
For models with 2 outputs, [P\_2] or [n\_2] will be displayed. Set as above.

The Pressure switch operates within a set pressure range (from P1L to P1H) during window comparator mode. Set P1L (switch lower limit) and P1H (switch upper limit) using the setting procedure above. When reversed output is selected, [n1L] and [n1H] are displayed.

### Zero clear of Display

The display is reset to zero when the **▲** and **▼** buttons are pressed simultaneously for 1 second. For the first operation, always perform zero clear with no pressure applied.

# Function Setting

## ■ Function selection mode

In measurement mode, press the **[S]** button for 2 seconds or longer to display [F 0]. Select to display the function to be changed, [F□□].

Press the **[S]** button for 2 seconds or longer in function selection mode to return to measurement mode.

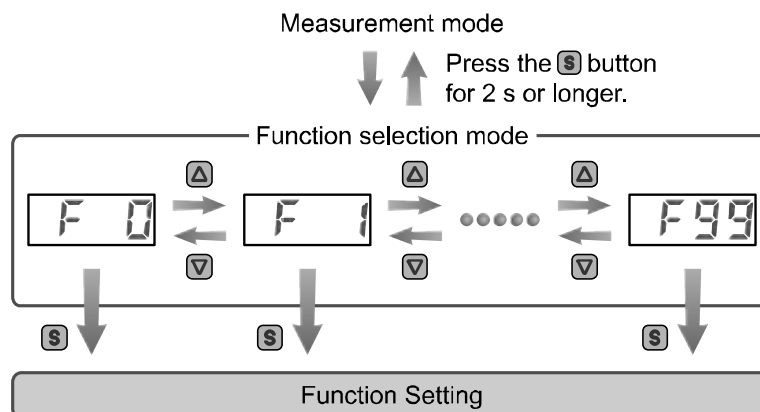

\*: Some functions are not available depending on part number. All functions are displayed with [F□□] followed by the function description. If a function is not available, the function is displayed as [---].

## ■ Default setting

At the time of shipment, the following settings are provided.

If this condition is acceptable, then keep these settings.

To change the settings, enter function selection mode.

### • [F 0] Units selection function ➡ Page 25

Unit specification	Model	Default setting
Nil or M	ISE10	MPa
	ZSE10(F)	kPa
P	ISE10	psi
	ZSE10(F)	

### • [F 1] Setting of OUT1 ➡ Page 26

Item	Description	Default setting
Output mode	Select hysteresis mode, window comparator mode or OFF mode.	Hysteresis mode
Reversed output	Select reversed output.	Normal output
Pressure setting	Set the ON or OFF point of the switch output	ISE10: 0.500 MPa ZSE10: -50.5 kPa ZSE10F: 50.0 kPa
Hysteresis	Set the hysteresis to prevent chattering.	ISE10: 0.050 MPa ZSE10: 5.1 kPa ZSE10F: 5.0 kPa

- [F 2] Setting of OUT2 ➡ Page 29  
Same setting as [F 1] OUT1.

- Other parameter setting

Item	Page	Default setting
[F 3] Response time	page 31	2.5 ms
[F 4] Auto-preset function	page 32	Manual
[F 6] Fine adjustment of display value	page 34	0%
[F11] Display resolution	page 35	1000-split
[F80] Power saving mode	page 36	OFF
[F81] Security code	page 37	OFF
[F90] Setting of all functions	page 38	OFF
[F97] Copy function	page 40	OFF
[F98] Check of output	page 42	Normal
[F99] Reset to the default setting	page 44	OFF



## ■[F 0] Units selection function

Only the product with Units selection function can be set.

The displayed unit can be changed, and depends on the pressure range.

(kPa/MPa units are available when the product does not have the units selection function).

### <Operation>

Press the  $\Delta$  or  $\nabla$  button in function selection mode to display [F 0].

Press the  $\text{S}$  button.  $\downarrow$  Move on to select the display unit.

### Select the Display Unit

Press the  $\Delta$  or  $\nabla$  button to select the display unit.

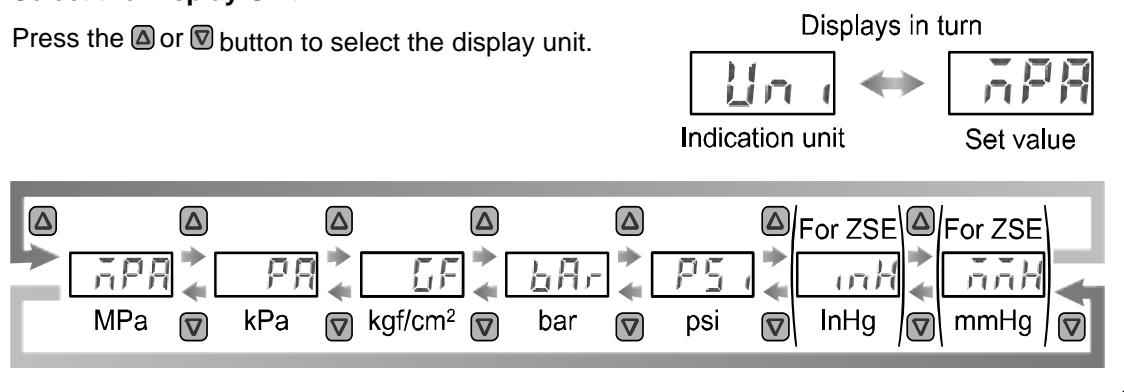

Press the  $\text{S}$  button to set.  $\downarrow$  Return to function selection mode.

Setting of [F 0] Units selection function completed

### •Display unit and minimum setting unit

Unit	ZSE10F	ZSE10	ISE10
MPa	0.001	0.001	0.001
kPa	0.1	0.1	1
kgf/cm <sup>2</sup>	0.001	0.001	0.01
bar	0.001	0.001	0.01
psi	0.02	0.01	0.1
InHg	0.1	0.1	-
mmHg	1	1	-

## ■[F 1] Setting of OUT1

Set output method of OUT1.

The output turns on when the pressure exceeds the set value. The default setting of the output set value is the central value between the atmospheric pressure and the upper limit of the rated pressure range.

For the operation of each setting, refer to "List of output modes" on page 28.

### <Operation>

Press the  $\Delta$  or  $\nabla$  button in function selection mode to display [F 1].

Press the  $\text{S}$  button.  $\downarrow$  Move on to setting of output mode.

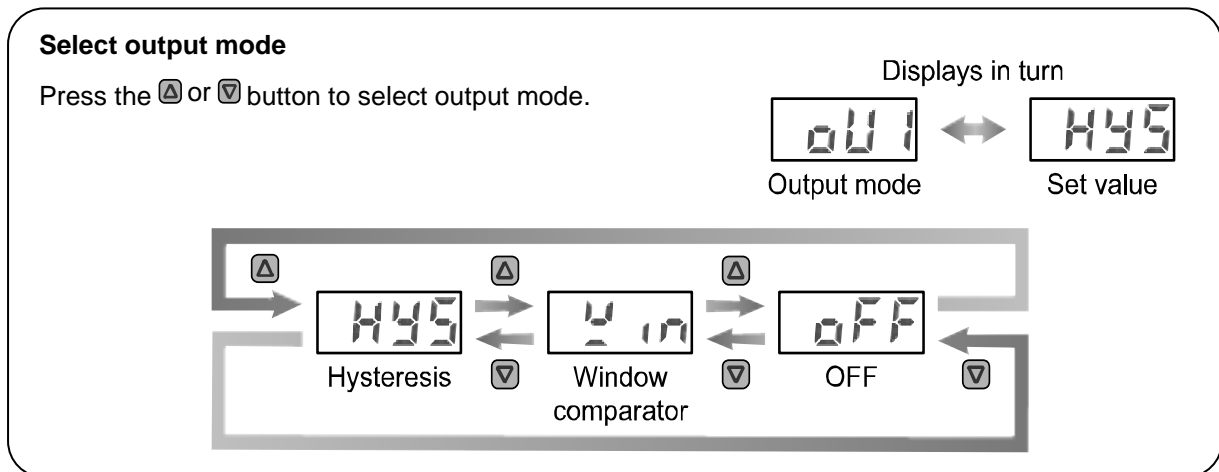

Press the  $\text{S}$  button to set.  $\downarrow$  Move on to setting of reversed output.

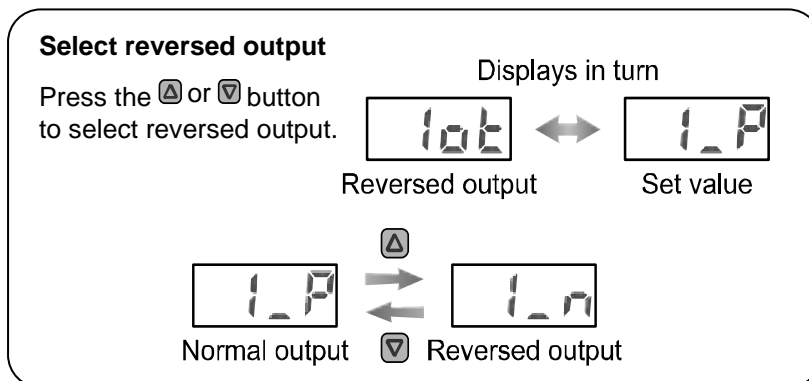

Press the  $\text{S}$  button to set.  $\downarrow$  Move on to setting of pressure.

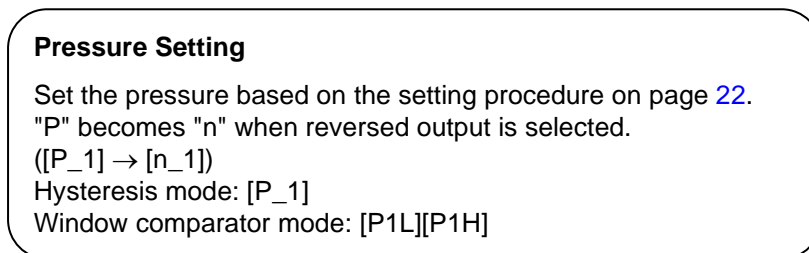



Press the  $\text{S}$  button to set.  $\downarrow$  Move on to setting of hysteresis.

[oFF] (unused) selected.

Press the  $\text{S}$  button to set.

Move on to setting of display colour.

### Setting of Hysteresis

Press the  or  button to select hysteresis.

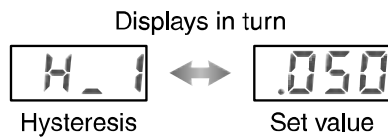

Press the  button to set.  Return to function selection mode. 

Setting of [F 1] operation of OUT1 completed

\*1: The selected parameter become effective after pressing the  button.

\*2: After setting, it is possible to move to measurement mode by pressing the  button for 2 seconds or longer.

\*3: When using with OUT1 turned off, select "OFF" in output mode.

•List of output modes

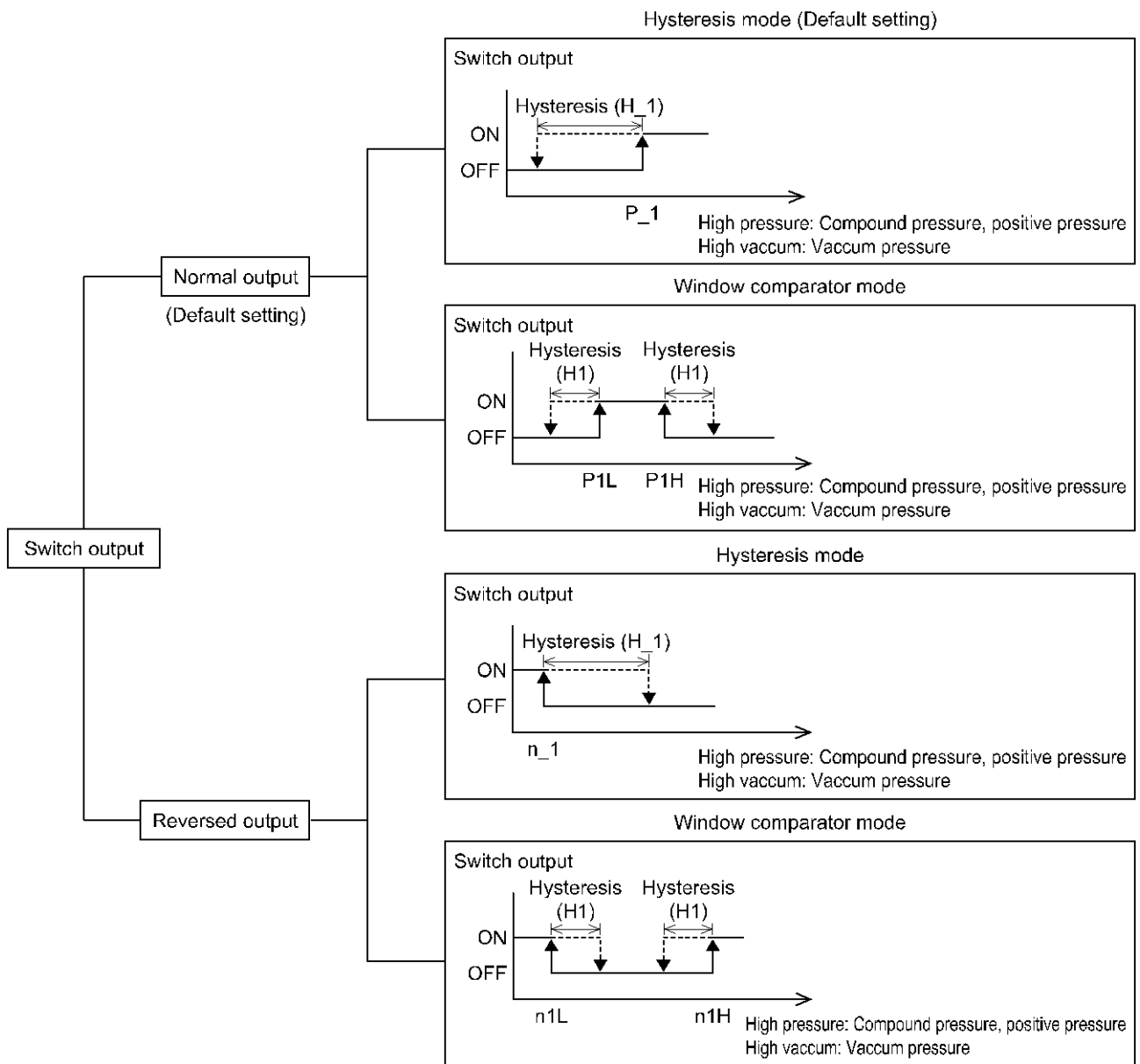

If the set point when the switch output is changed is outside the set pressure range due to switching between normal and reversed output, the hysteresis will automatically be compensated.

\*: The above figure shows the operation of OUT1.

For the operation of OUT2, "1" shown in the figure above becomes "2". (Ex)  $P_{11} \rightarrow P_{21}$

## ■[F 2] Setting of OUT2

Set output method of OUT2.

The output turns on when the pressure exceeds the set value. The default setting of the output set value is the central value between the atmospheric pressure and the upper limit of the rated pressure range.

For the operation of each setting item, refer to "List of output modes" on page 28.

### <Operation>

Press the  $\Delta$  or  $\nabla$  button in function selection mode to display [F 2].

Press the  $\text{S}$  button.  $\downarrow$  Move on to setting of output mode.

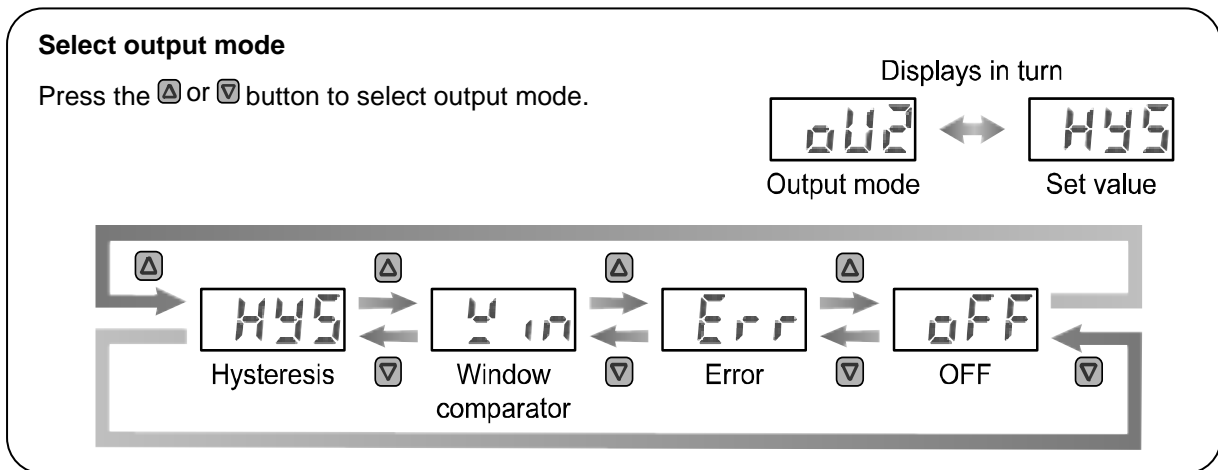

Press the  $\text{S}$  button to set.  $\downarrow$  Move on to setting of reversed output.

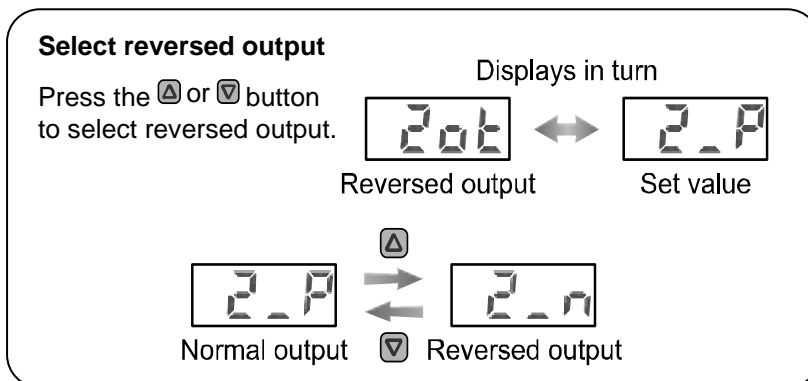

Press the  $\text{S}$  button to set.  $\downarrow$  Move on to setting of pressure.

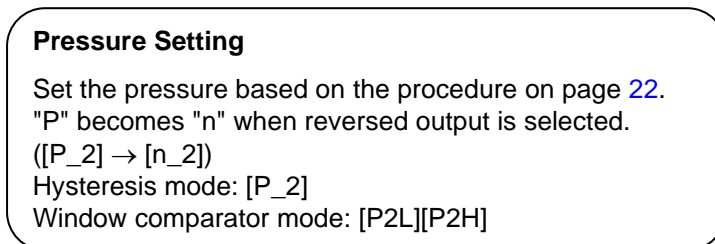

Press the  $\text{S}$  button to set.  $\downarrow$

[oFF] (unused) selected.

Press the  $\text{S}$  button to set.

Return to function selection mode.

Output mode [Err] selected.

Press the  $\text{S}$  button to set.

Return to function selection mode. \*4

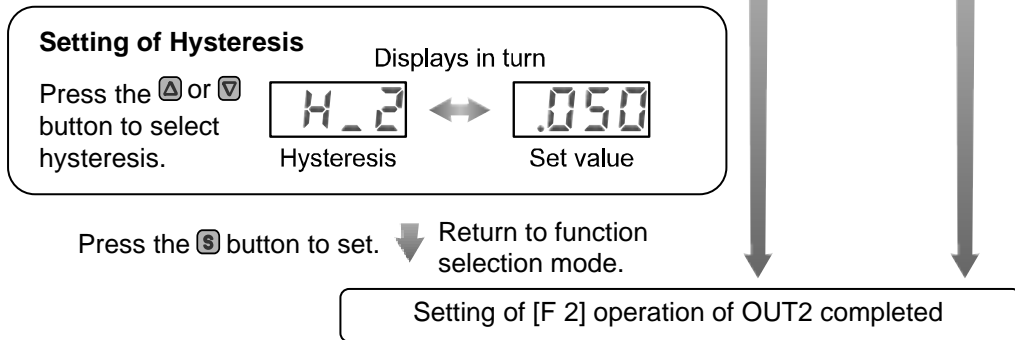

- \*1: The selected parameter becomes effective after pressing the  $S$  button.
- \*2: After setting, it is possible to move to measurement mode by pressing the  $S$  button for 2 seconds or longer.
- \*3: If the output specification is 1 output or Analogue output, the display shows [---], and this function cannot be set.
- \*4: When "Err" is selected in output mode, after normal and reversed display function, the display will return to [F 2].  
Output when error other than Er2 or Er3 is displayed. (Er0, 4, 7 may not be output depending on the status of the data)
- \*5: When using with OUT2 turned off, select "OFF" in output mode.

## ■[F 3] Response time

Select the response time of the switch output.

Output chattering can be prevented by setting the response time.

### <Operation>

Press the  $\Delta$  or  $\nabla$  button in function selection mode to display [F 3].

Press the  $\text{\$}$  button.  $\downarrow$  Move on to setting of response time.

**Setting of response time**

Press the  $\Delta$  or  $\nabla$  button to select response time.

Displays in turn

Response time      Set value

2.5 ms    20 ms    100 ms    500 ms    1000 ms    2000 ms



Press the  $\text{\$}$  button to set.  $\downarrow$  Return to function selection mode.



Setting of [F 3] Response time completed

## ■[F 4] Auto-preset function

When hysteresis mode is selected, the auto-preset function can calculate an optimum pressure value automatically based on the on-going operation.

### <Operation>

Press the  or  button in function selection mode to display [F 4].

Press the  button.  Move on to setting of auto-preset.

### Setting of Auto-preset

Press the  or  button to select auto-preset.

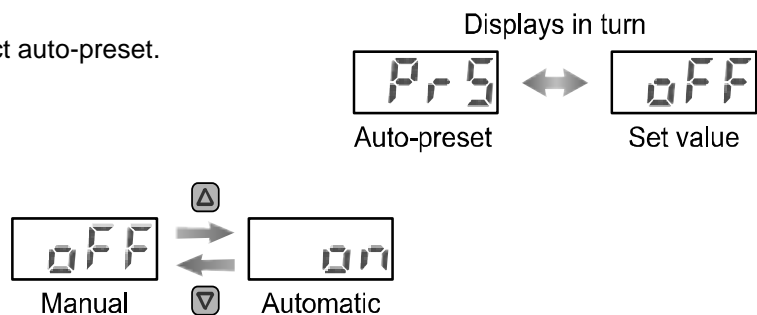

Press the  button to set.  Return to function selection mode.

Setting of [F 4] Auto-preset function completed

Press the  button during measurement mode to set the pressure.

Then press the  button again to change the pressure setting, while the display is flashing.



•Auto-preset

When auto-preset is selected in function selection mode, the set pressure can be calculated and stored from a measured pressure value. The set value is automatically optimized by repeating the suction and release of the workpiece during setting.

1, Selection of auto-preset OUT1

Press the **S** button in measurement mode to display "AP1".  
(If OUT1 does not need to be set, press the **▲** and **▼** buttons simultaneously for 1 second or longer to move to "AP2").



Auto-preset is ready

2, Preparation of OUT1 device

Prepare the device for which the pressure of OUT1 is to be set.

3, Setting of auto-preset value of OUT1

Press the **S** button to display "A1L".  
After measurement starts, operate the device and change the pressure. When the pressure change is detected, "A1H" will appear automatically, and so continue to operate the device.  
(If the **▲** and **▼** buttons are pressed simultaneously for 1 second or longer while "A1L" is displayed, measurement is stopped and "AP2" will appear).

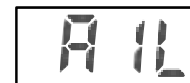

Auto-preset is being set

4, Selection of auto-preset OUT2

Press the **S** button to set "P\_1" and "H\_1" ("n\_1" and "H\_1" for reversed mode) and display "AP2".  
(If OUT2 does not need to be set, press the **▲** and **▼** buttons simultaneously for 1 second or longer to return to measurement mode).

5, Preparation and setting of OUT2 device

Prepare the device for which the pressure of OUT2 is to be set, and perform the setting of OUT2 in the same way as for OUT1.  
After "A2L" is displayed and measurement starts, the pressure change will be detected, and "A2H" will appear automatically.  
(If the **▲** and **▼** buttons are pressed simultaneously for 1 second or longer when "A2L" is displayed, measurement is stopped and the display will return to measurement mode).

6, Completion of setting

Press the **S** button to set "P\_2" and "H\_2" ("n\_2" and "H\_2" for reversed mode) and complete auto-preset mode. After that, the display will return to measurement mode.

The set values for OUT1 are displayed in auto-preset mode as follows.

•Normal output

$$P_1 = A - (A - B) / 4$$

$$H_1 = (A - B) / 2$$

•Reversed output

$$n_1 = B + (A - B) / 4$$

$$H_1 = (A - B) / 2$$

A = Max. pressure

B = Min. pressure



The set values of OUT2 become as follows "\_", i.e. "P\_2", "n\_2" and "H\_2".

If this setting is not necessary, press the **▲** and **▼** buttons simultaneously for 1 second or longer.

## ■[F 6] Fine adjustment of display value



This function is used to manually perform fine adjustment of the displayed pressure. It is adjustable within the range  $\pm 5\%$ R.D.

### <Operation>



Press the  or  button in function selection mode to display [F 6].

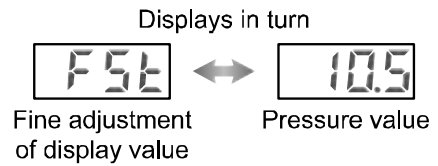

Press the  button.  Move on to setting of fine adjustment of display value.

### Setting of fine adjustment of display value

Press the  or  button to change the set pressure value.



Press the  button to set. 

If the  and  buttons are pressed simultaneously for 1 second or longer while [F5C] is displayed, the adjusted value is set.

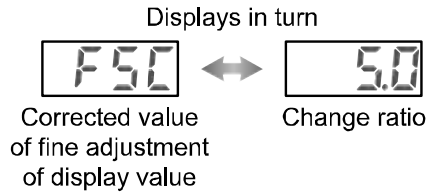

Press the  button to set.  Return to function selection mode.

Setting of [F 6] Fine adjustment of display value completed

## ■[F11] Display resolution

This function is used to change the pressure display resolution.  
This can be used to prevent the digits from flickering on the display.

### <Operation>

Press the  $\Delta$  or  $\nabla$  button in function selection mode to display [F11].

Press the  $\text{S}$  button.  $\downarrow$  Move on to setting of display resolution.

### Setting of display resolution

Press the  $\Delta$  or  $\nabla$  button to select display resolution.

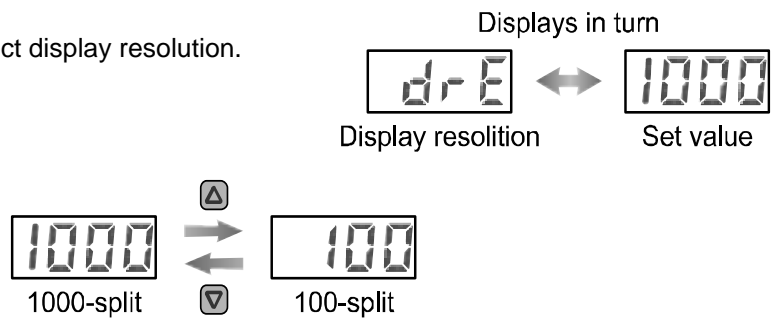

Press the  $\text{S}$  button to set.  $\downarrow$  Return to function selection mode.

Setting of [F11] Display resolution completed

\*: Not selectable depending on selected display units.

The display resolution selectable unit is MPa, kPa (for ZSE only), kgf/cm<sup>2</sup>, bar, psi and inHg.

The display units kgf/cm<sup>2</sup>, bar, psi and inHg are selectable only for models with the units selection function.

➡ [F 0] Units selection function on page 25.

## ■[F80] Power saving mode

Power saving mode is selectable.

When the Pressure switch is left for 30 seconds with no key operation, it will enter power saving mode.

### <Operation>

Press the or button in function selection mode to display [F80].

Press the button. Move on to setting of power saving mode.

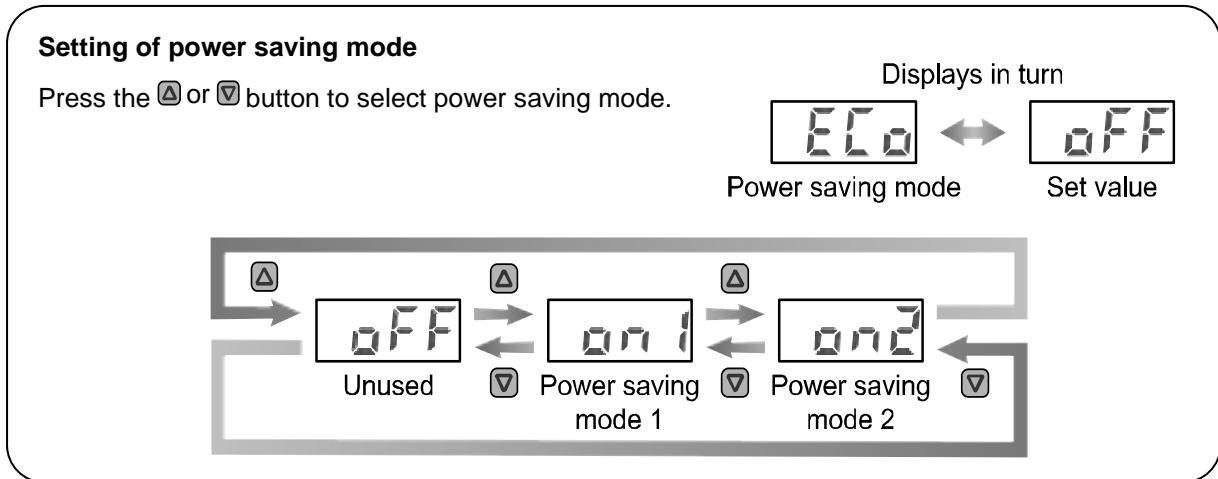

Press the button to set. Return to function selection mode.

Setting of [F80] Power saving mode completed

Power saving mode 1 remains enabled until turned off.

In power saving mode 1, the brightness of the whole display will be reduced.

In power saving mode 2, any key operation will return the normal display. If there is no key operation for 30 seconds or more, the display will return to power saving mode (only in measurement mode).

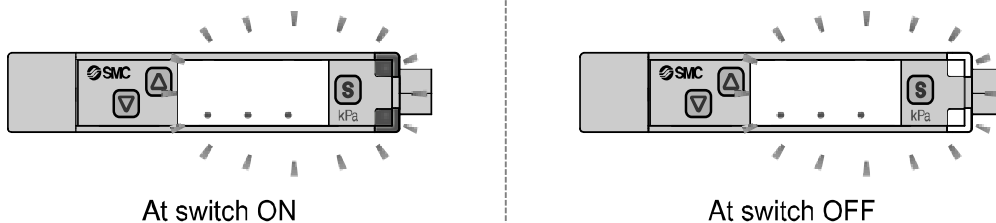

In power saving mode 2, only the decimal points flash, and the point of flashing moves.





## ■[F81] Security code



A security code can be selected, which must be entered to unlock the keys when the keys are locked.

### <Operation>

Press the  or  button in function selection mode to display [F81].

Press the  button.  Move on to setting of security code.

### Setting of security code

Press the  or  button to select security code.

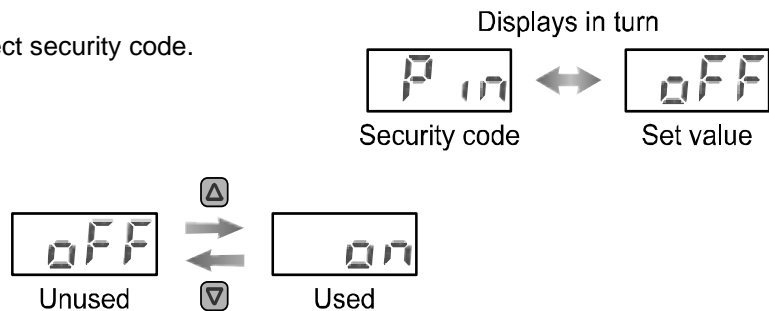

Press the  button to set.  Return to function selection mode.

Setting of [F81] Security code completed

If the security code is used, it becomes necessary to enter the security code to release the key lock. The security code can be decided optionally by the operator. The default setting is "000".

Refer to page 46 for the security code input.

## ■[F90] Setting of all functions

All functions can be set, one after the other.

### <Operation>

Press the or button in function selection mode to display [F90].

Press the button. ↓ Move on to setting of all functions.

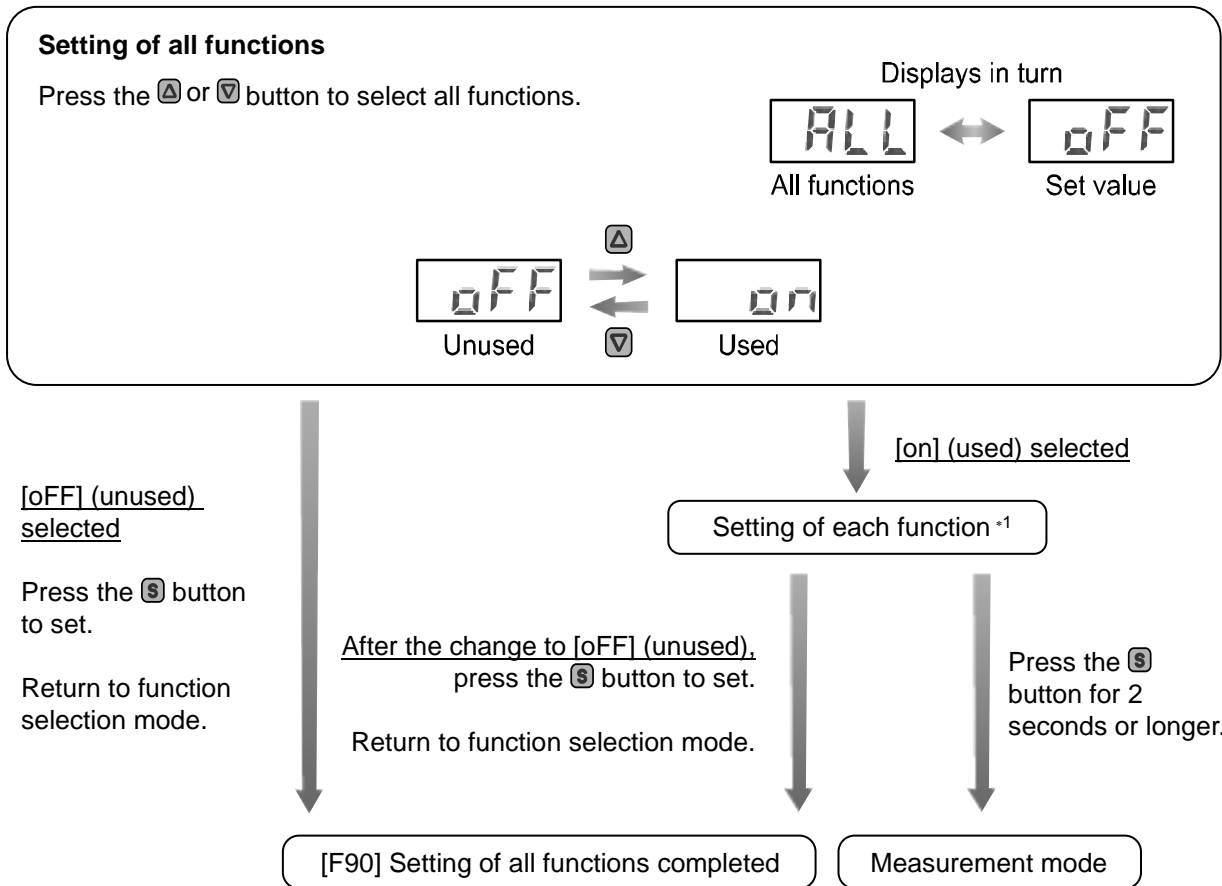

#### \*1: Setting of functions

Every time the button is pressed, the function steps in the order of Function of settings on page 39.

Set using the or button.

Refer to each section for the setting details.

•Order of Function of setting

Order	Function	Applicable model
1	Selection of display unit	All models
2	Select output mode (OUT1)	All models
3	Select reversed output (OUT1)	All models
4	Setting of pressure (OUT1)	All models
5	Setting of hysteresis (OUT1)	All models
6	Select output mode (OUT2)	Only for the product with output specification of NPN2 and PNP2
7	Select reversed output (OUT2)	
8	Setting of pressure (OUT2)	
9	Setting of hysteresis (OUT2)	
10	Response time	All models
11	Display resolution	All models
12	Auto-preset function	All models
13	Fine adjustment of display value	All models
14	Power saving mode	All models
15	Security code	All models

\*: Measurement mode will return from any setting item by pressing the  button for 2 seconds or longer.

\*: Function that will be set by the return to the measurement mode.

## ■[F97] Copy function

The set values of pressure and functions (except for corrected value of fine adjustment of display value) can be copied. When the pressure range, output and unit specifications are the same, this function becomes available. The set value can be copied to up to 10 Pressure switches simultaneously.

### <Connection>

Connect the Pressure switches with the power supply turned off.

Connect the FUNC terminals of the copy source Pressure switch and the copy destination Pressure switches, and then turn on the power supply.

The copy source Pressure switch is the switch from which the setting is to be copied.

The copy destination Pressure switch is the switch to which the setting is to be copied.

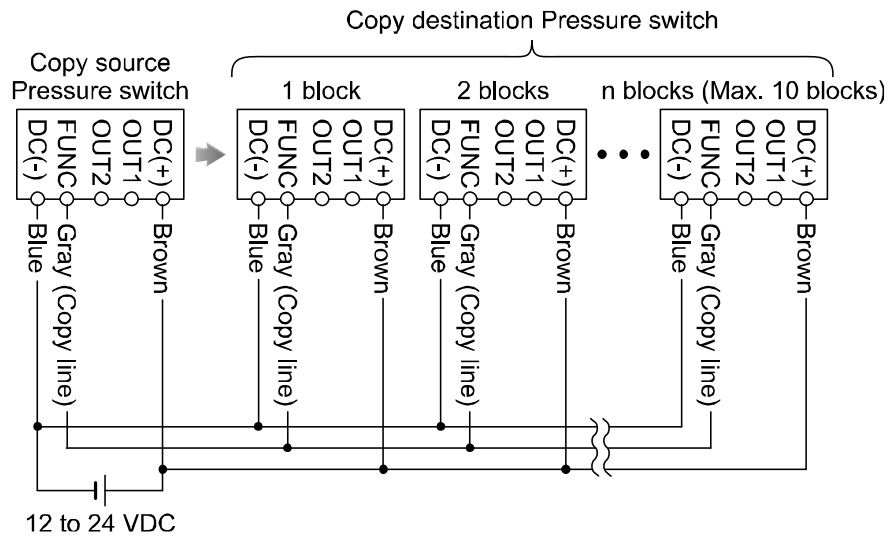

### <Operation>

Press the  $\Delta$  or  $\nabla$  button of the copy source Pressure switch in function selection mode to display [F97].

Press the  $\text{S}$  button.  $\downarrow$  Move on to the selection of copy function.

#### Selection of copy function

Press the  $\Delta$  or  $\nabla$  button to select copy function.

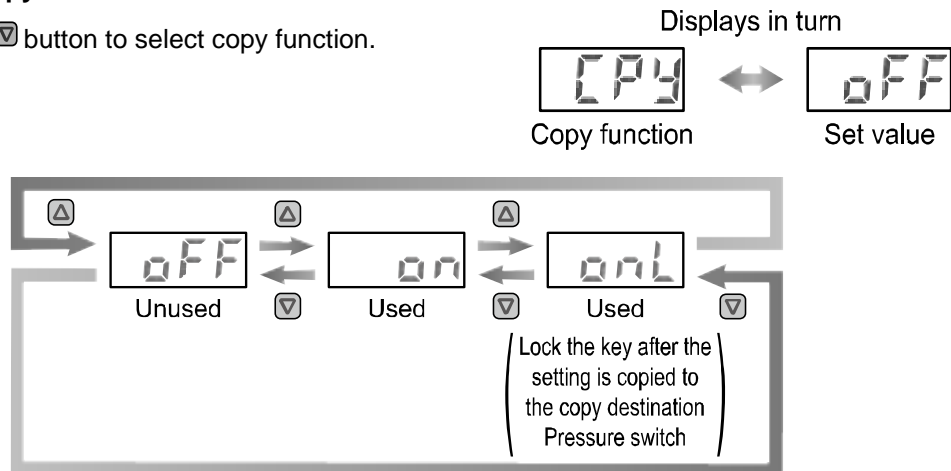

Press the  $\text{S}$  button to set.  $\downarrow$



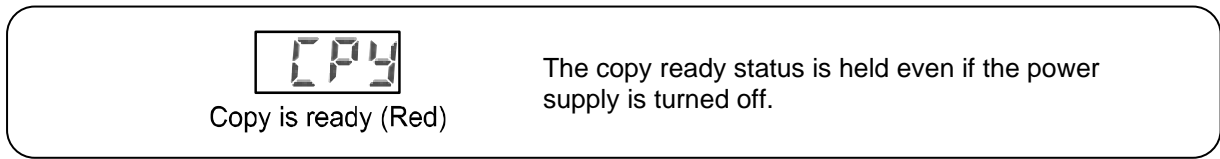

Press the **[S]** button to start copying. ↓

	The copy source Pressure switch	The copy destination Pressure switch
Sending/Receiving	<p>Flashing (Red)</p>	<p>Flashing (Red)</p>
Copy completed	<p>Displays in turn</p> <p>(Red)</p>	<p>Displays in turn</p> <p>(Red)</p>

Press the **[S]** button.

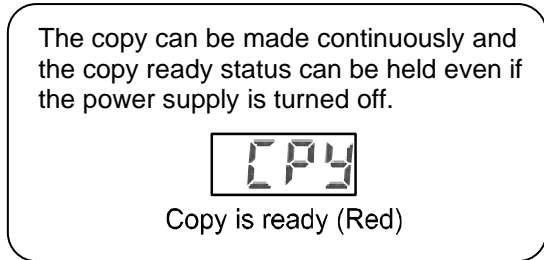

Press the **[▲]** and **[▼]** buttons simultaneously for 1 second or longer.

Press the **[S]** button.

To complete the copy function, press the **[▲]** and **[▼]** buttons simultaneously for 1 second or longer.

Setting of [F97] Copy function completed

\*: If the copy to the copy destination Pressure switch is not completed, it is detected as a copy function sending/receiving error. Press the **[▲]** and **[▼]** buttons simultaneously for 1 second or longer to return to measurement mode. Then, check the wiring and specifications of the switch and retry copy function.

■[F98] Check of output

Output from the switch can be confirmed.  
It can be selected to provide or not to provide the output.

<Operation>

Press the or button in function selection mode to display [F98].

Press the button. Move on to check of output.

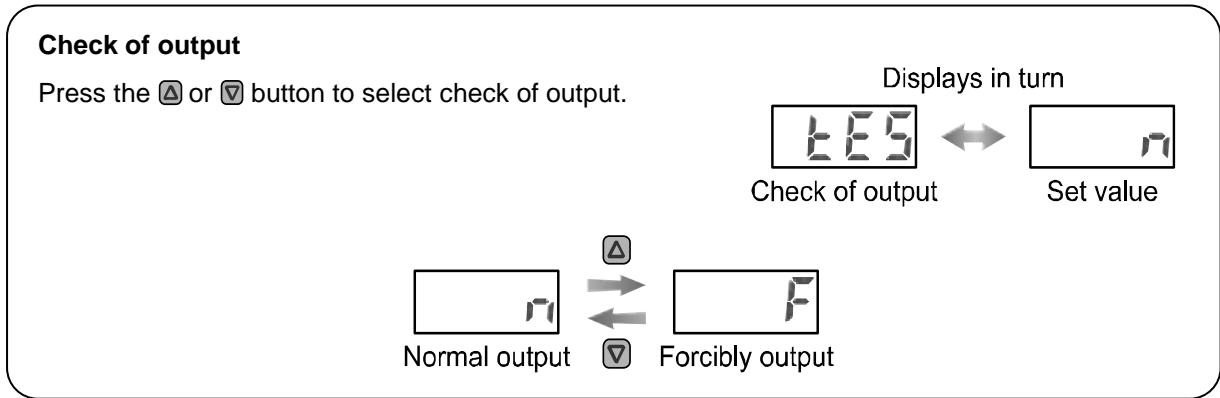

If [n] (normal output) is selected, press the button to set.

Return to function selection mode.

If [F] (forcibly output) is selected, press the button to set.

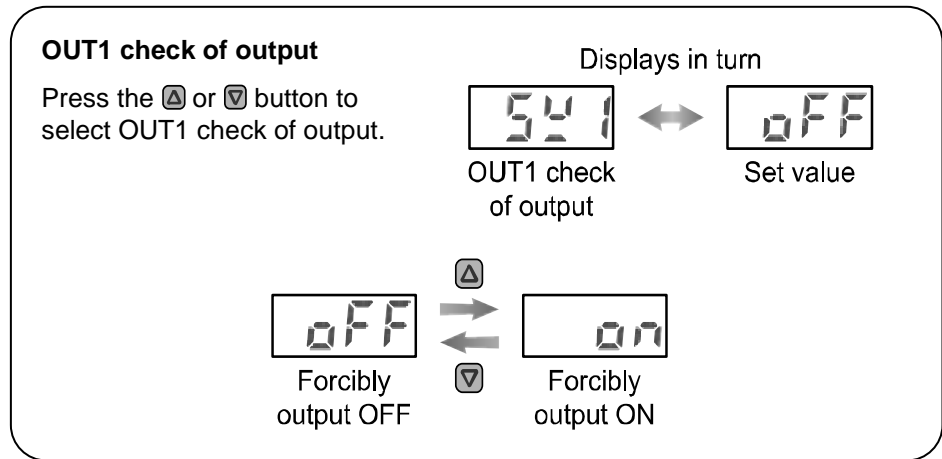

If OUT2 output is not provided, press the button to set after returning to [n] (normal output).

Return to function selection mode.

If OUT2 output is provided, press the button to set.

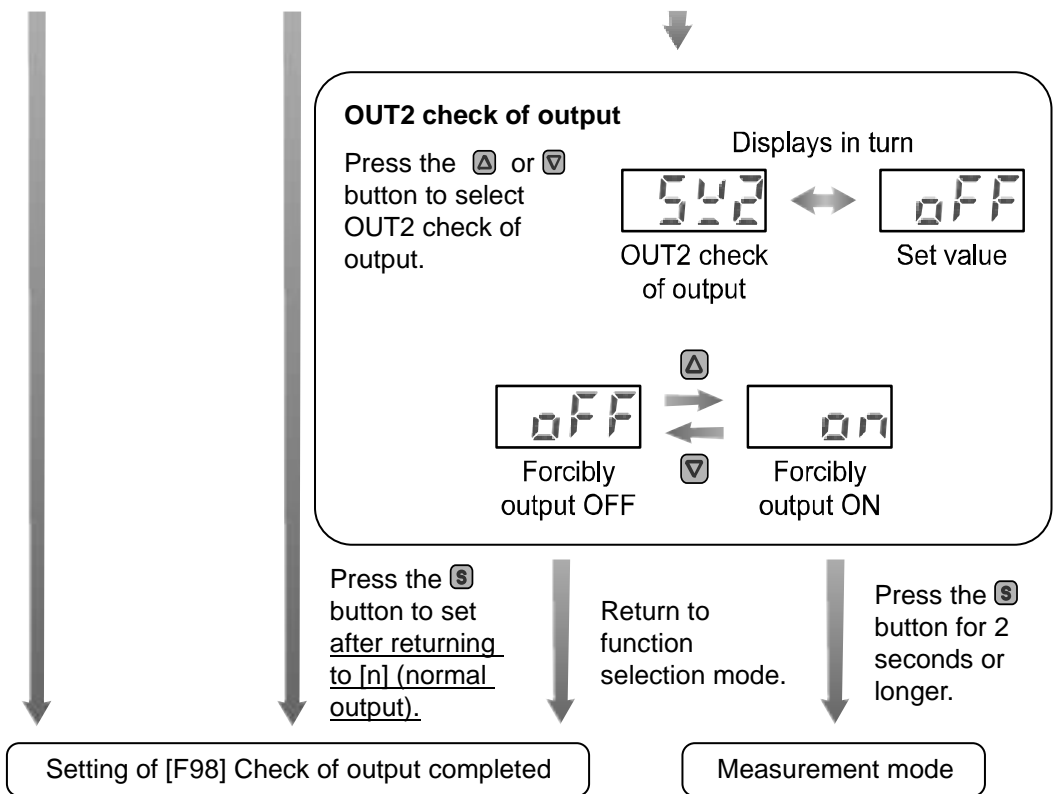





\*: If the  $\text{S}$  button is pressed for 2 seconds or longer, the mode is returned to measurement mode regardless of the current mode.

## ■[F99] Reset to the default setting





If the setting of the pressure switch becomes unknown, the default setting can be restored.

### <Operation>

Press the  or  button in function selection mode to display [F99].

Press the  button.  Move on to reset to the default setting.

#### Reset to the default setting

Set the display [ON] by pressing the  or  button, then press the  and  buttons simultaneously for 5 seconds or longer.

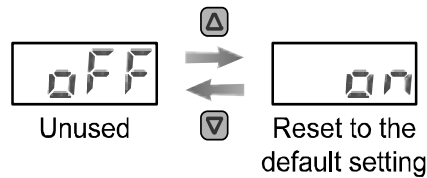

Displays in turn

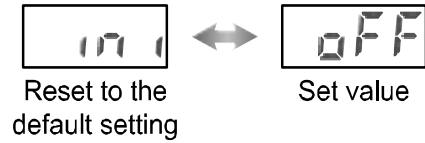

[oFF] (unused) selected

Press the  button to set.

Return to function selection mode.

The setting is reset to the default setting, and the mode returns to the function selection mode.

Setting of [F99] Reset to the default setting completed

## Other Settings

### ○Peak/Bottom value display



The maximum (minimum) pressure from when the power was supplied to this moment is detected and updated. In peak/bottom display mode, this pressure is displayed.

For peak display, when the  button is pressed for 1 second or longer, the maximum pressure and "Hi" starts flashing, and is held.

To release holding the display of the maximum pressure, press the  button for 1 second or longer again to return to measurement mode.

For bottom display, when the  button is pressed for 1 second or longer, the minimum pressure and "Lo" starts flashing and is held.



To release holding the display of the minimum pressure, press the  button for 1 second or longer again to return to measurement mode.

If the  and  buttons are pressed simultaneously for 1 second or longer while the pressure is being held, the maximum (minimum) values are reset.

### ○Zero clear

A displayed value can be adjusted to zero when the pressure to be measured is within  $\pm 7\%$ F.S. ( $\pm 3.5\%$ F.S. for compound pressure) of the pressure at the time of shipment from the factory.

(A tolerance range of  $\pm 1\%$ F.S. may apply due to individual product differences).

Press the  and  buttons simultaneously for 1 second or longer, to clear the display to "0".

The display will return to measurement mode automatically.

For analogue output, the analogue output will be changed along with the display.

### ○Key lock

The key lock function is used to prevent errors occurring due to unintentional changes of the set values. If a button operation is performed while the key lock setting is ON, "LoC" is displayed for approximately 1 second.

(When the  button is pressed, the set pressure will be displayed following "LoC").



#### <Operation - Without security code input- >

- 1, Press the  button for 5 seconds or longer in measurement mode.

The current setting "LoC" or "UnL" is displayed.

(Selecting or releasing the key lock is carried out in a similar way).



- 2, Press the  or  button to select key lock (or key unlock).

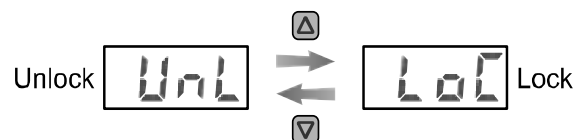

- 3, Press the  button to store the setting.

### <Operation - With security code input- >

#### •Locking

- 1, Press the **[S]** button for 5 seconds or longer in measurement mode.  
The current setting "UnL" is displayed.



- 2, Press the **[▲]** or **[▼]** button to select keys lock "LoC".

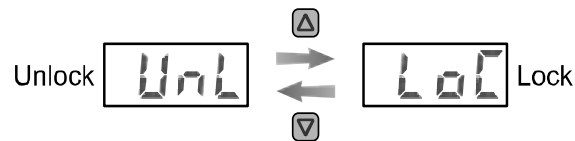

- 3, Press the **[S]** button to store the setting.

#### •Unlocking

- 1, Press the **[S]** button for 5 seconds or longer in measurement mode.  
The current setting "LoC" is displayed.

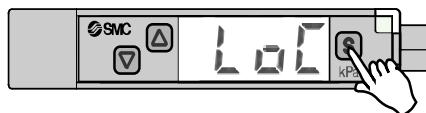

- 2, Press the **[▲]** or **[▼]** button to select keys unlock "UnL".

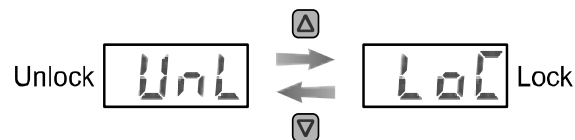

- 3, When the **[S]** button is pressed, input of the security code will be requested.  
For how to enter the security code, refer to "How to enter the security code" on page 47.

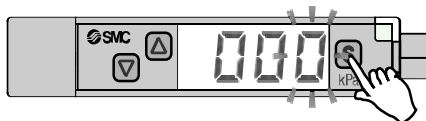

- 4, If the security code entered is correct, the display will change to "UnL". Press any of the **[▲]**, **[S]** or **[▼]** buttons to release the key lock and return to measurement mode.  
If the security code entered is incorrect, "FAL" will be displayed and the security code must be entered again. If an incorrect security code is entered three times, "LoC" is displayed and the display will return to measurement mode.

•How to change the security code

At the time of shipment, the security code is set to "000", but this can be changed to any number.

<Operation>

- 1, After the key lock setting has been completed, perform the first three steps in the unlocking procedure (page 46).
- 2, After the security code has been entered and the display changes to "UnL", press the **S** and **V** buttons simultaneously for 5 seconds or longer.  
"000" is displayed and a new security code can now be entered.  
For how to enter the security code, refer to "How to enter the security code".  
The new security code will be displayed.
- 3, After checking the security code is as required, press the **S** button for 1 second or longer.  
The display will return to measurement mode.  
At this time, if the **A** or **V** button is pressed, any security code changes are lost, and the change of security code procedure must be repeated.

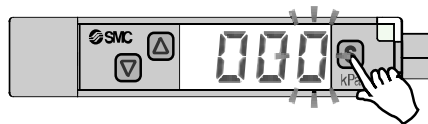

•How to enter the security code

The first digit will start flashing.

Press the **A** or **V** button to select a value.

Press the **S** button to set and the next digit will start flashing.

(If the **S** button is pressed at the last digit, the first digit will start flashing again).

After the setting is completed, press the **S** button for 1 second or longer.

(If a key operation is not performed for 30 seconds while entering the security code, the measurement mode will return).

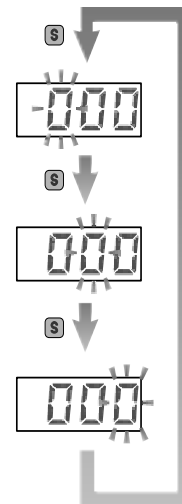

## Maintenance

### **How to reset the product for a power cut or forcible de-energizing**

The setting of the product will be retained as it was before a power cut or de-energizing.

The output condition is also basically recovered to that before a power cut or de-energizing, but may change depending on the operating environment.

Therefore, check the safety of the whole installation before operating the product.

If the installation is using accurate control, wait until the product has warmed up (approximately 10 to 15 minutes).

## If the security code is forgotten

If you have forgotten your security code, please contact SMC directly.



# Troubleshooting

## ○Troubleshooting

Applicable Pressure switch: **ZSE10(F)/ISE10**

If the cause of the failure cannot be identified and normal operation can be recovered by replacement with a new Pressure switch, this indicates that the Pressure switch itself is faulty. Pressure switch damage can be caused by the operating environment (network construction, etc.), therefore contact SMC.

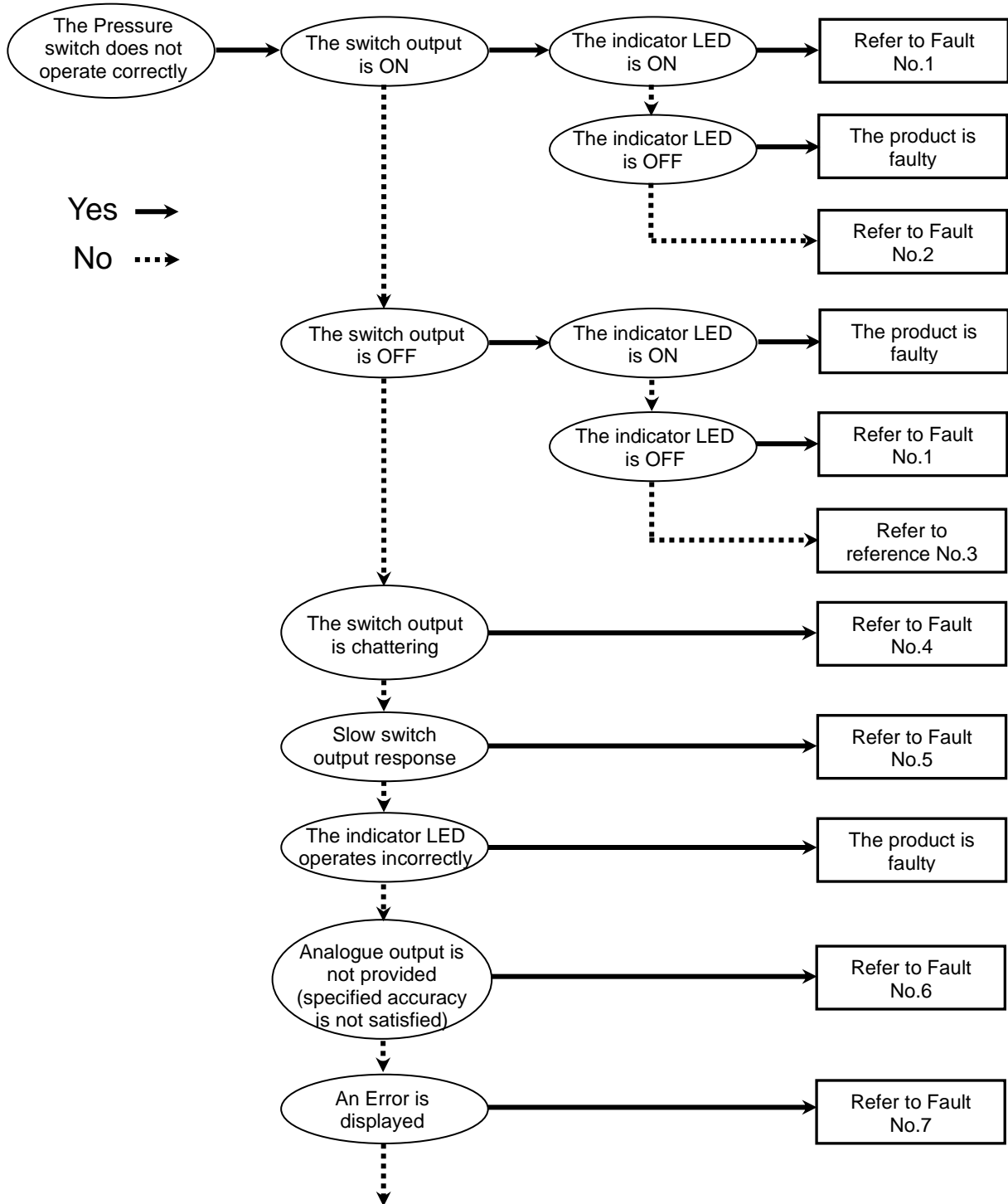

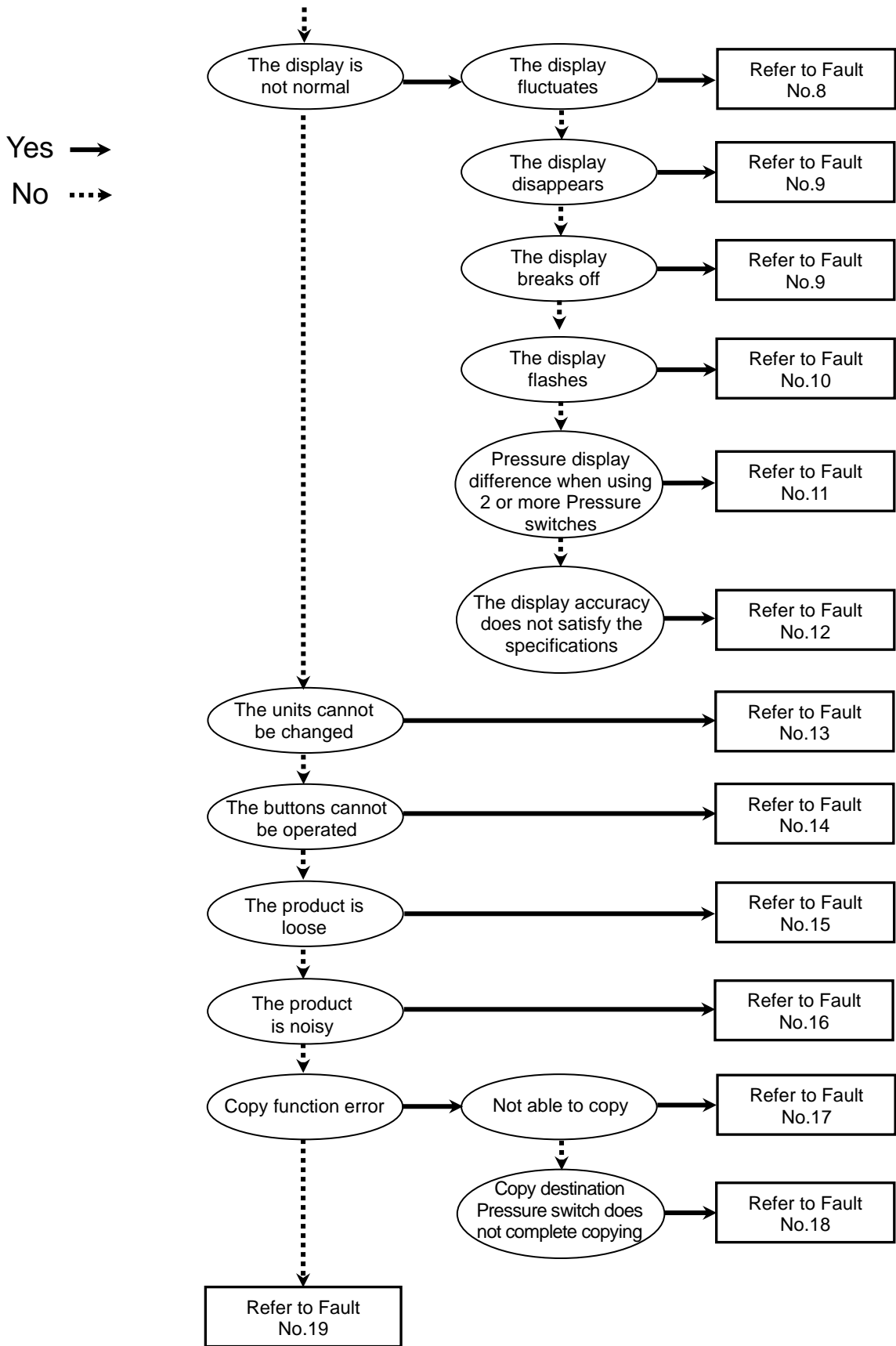

○Faults and countermeasures

Fault No.	Fault	Possible cause	Investigation method	Countermeasure
1	<ul style="list-style-type: none"> <li>●Output remains ON. Indicator LED remains ON.</li> <li>●Output remains OFF. Indicator LED remains OFF.</li> </ul>	Incorrect pressure setting	(1) Check the set pressure. (2) Check the operation mode, hysteresis and output type. (hysteresis mode / window comparator mode, normal / reversed output)	(1) Reset the pressure setting. (2) Reset the function settings.
		Product failure		Replace the product.
2	Output remains ON. Indicator LED works correctly.	Incorrect wiring	Check the wiring of the output. Check if the load is connected directly to DC(+) or DC(-).	Correct the wiring.
		Product failure		Replace the product.
3	Output remains OFF. Indicator LED works correctly.	Incorrect wiring	Check the wiring of the output. Check if the load is connected directly to DC(+) or DC(-).	Correct the wiring.
		Unsuitable model selection	Check if PNP is used when NPN should have been selected, or the other way around.	Review the selected model (output type).
		Broken lead wire	Check if there is bending stress applied to any parts of the lead wire. (bending radius and tensile force applied).	Correct the wiring conditions. (adjust the tensile force and increase the bending radius).
		Product failure		Replace the product.
4	Switch output generates chattering.	Incorrect wiring	Check the wiring. Check that the brown and blue wires are connected to DC(+) and DC(-) respectively, and if the output wiring is loose (contact failure).	Correct the wiring.
		Incorrect settings	(1) Check the set pressure. (2) Check that the hysteresis range is not too narrow. (3) Check the response time set at initial setting. Check that the response time is not too short.	(1) Reset the pressure setting. (2) Increase the hysteresis. (3) Reset the function settings.
		Product failure		Replace the product.
5	Slow switch output response	Incorrect pressure setting	Check the pressure setting. Check that the detected pressure and the set pressure value are not the same or not too close.	Reset the pressure setting. Set the pressure setting value so it is not too close to the detected pressure.

Fault No.	Fault	Possible cause	Investigation method	Countermeasure
6	Analogue output (OUT2) is not provided. (specified accuracy is not satisfied).	Incorrect wiring	Check that the analogue output (OUT2) is connected to a load.	Correct the wiring.
		Non-compliance with the load specification.	(1) Check that the correct load is connected. (2) Check that the impedance of the input equipment (A/D transformer) is suitable.	Connect a suitable load.
		Insufficient warm-up time	Check if the product satisfies the specified accuracy after 10 minutes warm up time.	After energizing, the display and output can drift. For detecting fine pressures, warm up the product for 10 to 15 minutes.
		Product failure		Replace the product.
7	<ul style="list-style-type: none"> <li>•An over current error (Er1, Er2) is displayed.</li> <li>•System error (Er0, Er4, Er6, Er7, Er8 or Er9) is displayed.</li> <li>•The display shows "HHH".</li> <li>•The display shows "LLL".</li> <li>•Residual pressure error (Er3) is displayed.</li> </ul>	Over current to the output (Er1, Er2)	(1) Check that the switch output load current is not more than 80 mA. (2) Check that the connected load satisfies the specifications, and check the load for short circuits. (3) Check that any relay is connected with a surge voltage suppressor. (4) Check if the wiring is not in the same route as (or bundled together with) a high voltage cable or power cable.	(1), (2) Connect the load as specified. (3) Use a relay with a surge voltage suppressor or take measures to prevent noise. (4) Separate the wiring route from any high voltage cable or power cable.
		Incorrect operation of the internal data of the Pressure switch (Er0, Er4, Er6, Er7, Er8, Er9)	(1) Check that there is no noise interference such as static electricity, and check for noise sources. (2) Check that the power supply voltage is within the range 12 to 24 VDC $\pm 10\%$ .	(1) Remove the noise and the noise source (or take measures to prevent noise interference), and reset the product, or turn off the power supply and turn it on again. (2) Supply a correct voltage of 12 to 24 VDC $\pm 10\%$ .
		Applied pressure is over the upper limit (HHH).	(1) Check that the pressure is not above the upper limit of the set pressure range. (2) Check that foreign matter has not entered the piping.	(1) Adjust the pressure to within the set pressure range. (2) Take measures to prevent foreign matter from entering the piping.
		Applied pressure is under the lower limit (LLL).	(1) Check that the pressure is not below the lower limit of the set pressure range. (2) Check that foreign matter has not entered the piping.	(1) Adjust the pressure to within the set pressure range. (2) Take measures to prevent foreign matter from entering the piping.
		Pressure is not atmospheric pressure at zero-clear operation (Er3)	Check that during the zero clear operation, pressure above $\pm 7\%$ F.S. ( $\pm 3.5\%$ F.S. for compound pressure) was not applied.	Return the applied pressure to atmospheric pressure, and retry the zero clear operation.
		Product failure		Replace the product.

Fault No.	Fault	Possible cause	Investigation method	Countermeasure
8	Displayed value fluctuates.	Incorrect power supply	Check that the power supply voltage is within the range 12 to 24 VDC $\pm 10\%$ .	Supply the correct voltage of 12 to 24 VDC $\pm 10\%$ .
		Incorrect wiring	Check the wiring to the power supply. Check that the brown and blue wires are connected to DC(+) and DC(-) respectively and that the output wiring is not loose (contact failure).	Correct the wiring.
		Factory pressure change	Check if the factory pressure has changed.	If the fluctuation is not acceptable, the pressure switch display resolution can be changed
9	<ul style="list-style-type: none"> <li>•Indicator turns off.</li> <li>•A part of the display misses.</li> </ul>	Incorrect power supply	Check that the power supply voltage is within the range of 12 to 24 VDC $\pm 10\%$ .	Supply the correct voltage of 12 to 24 VDC $\pm 10\%$ .
		Power saving mode	Check if the power saving mode is selected.	Reset the function settings.
		Incorrect wiring	Check the power supply wiring. Check that the brown and blue wires are connected to DC(+) and DC(-) respectively and that the output wiring is not loose (contact failure).	Correct the wiring.
		Product failure		Replace the product.
10	Display is flashing.	The peak / bottom value display mode is selected.	Check if the peak value or bottom value display mode has been selected.	Turn off the peak / bottom value display mode if not required.
		Wiring failure	(1) Check the power supply wiring. (2) Check if there is bending stress applied to any parts of the lead wire.	(1) Correct the wiring (2) Correct the wiring conditions (reduce the tensile force and increase the bending radius).
11	Pressure display difference when using 2 or more Pressure switches.	Dispersion within the display accuracy range	Check if the dispersion is within the display accuracy range.	Use the fine adjustment mode to adjust the display if the dispersion is within the display accuracy range.
		Product failure		Replace the product.

Fault No.	Fault	Possible cause	Investigation method	Countermeasure
12	The pressure display accuracy does not satisfy the specifications.	Foreign matter	Check if any foreign matter has entered the pressure port.	Install a 5 μm filter to prevent foreign matter from entering the pressure port. Also, clean the filter regularly to prevent drainage deposits.
		Air or fluid leakage	Check if air or fluid are leaking from the piping.	Rework the piping. If an excessive tightening torque is applied, the mounting bracket, screws or the product may be damaged.
		Insufficient warm-up time	Check if the product satisfies the specified accuracy after 10 minutes warm up time.	After energizing, the display and output can drift. For detecting fine pressures, warm up the product for 10 to 15 minutes.
		Product failure		Replace the product.
13	The display units cannot be changed.	Improper model selection (Selection of model "without Units selection function")	Check if there is a "-M" at the end of the part number printed on the product	"M" in the part number means that the unit cannot be changed. (kPa↔MPa can be selected) *: The units selection function is not available in Japan due to a new measurement law. *: It is fixed to the SI unit "kPa", "MPa".
		Product failure		Replace the product.
14	The buttons cannot be operated.	Key lock mode	Check if the key lock mode is turned on.	Turn off the key lock mode.
		Product failure		Replace the product.
15	The product is loose.	Incorrect installation	Check that the panel mount adapter and the product are correctly assembled.	Mount the product on the panel correctly.
		Product failure		Replace the product.
16	The product is noisy.	Air or fluid leakage	Check if air or fluid are leaking from the piping.	Rework the piping. If an excessive tightening torque is applied, the mounting bracket, screws or the product may be damaged.
		Product failure		Replace the product.
17	<ul style="list-style-type: none"> <li>•Copy function error</li> <li>•Unable to copy</li> </ul>	Incorrect wiring	(1) Check the wiring connection at the FUNC terminal. (2) Check the power supply wiring.	Correct the wiring.
		Product failure		Replace the product.

Fault No.	Fault	Possible cause	Investigation method	Countermeasure
18	Copy destination Pressure switch does not complete the copy function.	Incorrect wiring	(1) Check the wiring connection at the FUNC terminal. Check the power supply wiring. (2) Check the lead wire lengths.	(1) Correct the wiring. (2) The maximum transmitting distance of the copy function is 4 m. Shorten the lead wire to 4 m or less.
		Improper model selected	The model number of the copy source Pressure switch and the copy destination Pressure switch are different from each other.	Check the model numbers. Copying is available when the pressure range, output specification and units specification are identical.
		Too many pressure switches connected	Check the number of connected copy destination Pressure switches.	The number of connected products for which copying is possible is up to 10 pcs. Reduce the number to 10 pcs or less.
		Product failure		Replace the product.
19	The operation is unstable. (chattering)	Pressure source fluctuation, small hysteresis or the response time is too short.	(1) Check the set pressure (hysteresis) (2) Check the response time	(1) Check the pressure setting. (2) Reset the function settings.
		Incorrect wiring or broken lead wire	(1) Check the power supply wiring. (2) Check if there is bending stress applied to any parts of the lead wire.	(1) Correct the wiring (2) Correct the wiring conditions (reduce the tensile force and increase the bending radius).
		Product failure		Replace the product.

○Error indication

This function is to display error location and content when a problem or an error occurs.

Error Name	Error Display	Error Type	Troubleshooting Method
Over current Error	Er 1 Er 2	The switch output load current is more than 80 mA.	Turn the power off and remove the cause of the over current. Then turn the power on.
Zero-clear Error	Er 3	During zero clear operation, pressure above $\pm 7\%$ F.S. ( $\pm 3.5\%$ F.S. for compound pressure) is applied. After 1 second, the mode will return to measurement mode. The zero clear range can vary $\pm 1\%$ F.S. with individual product differences.	Perform zero clear operation again after restoring the applied pressure to an atmospheric pressure condition.
Pressurizing Error	HHH	Pressure has exceeded the upper limit of the set pressure range.	Adjust the applied pressure to a level within the set pressure range.
	LLL	Pressure has exceeded the lower limit of the set pressure range.	
System Error	Er 0 Er 4 Er 6 Er 7 Er 8 Er 9	Displayed in the case of an internal data error.	Turn the power off and turn it on again. If resetting fails, an investigation by SMC Corporation will be required.

If the error can not be reset after the above measures are taken, then please contact SMC.



# Specifications

Model No.	ZSE10 (vacuum)	ZSE10F (compound)	ISE10 (positive pressure)	
Rated pressure range	0.0 to -101.0 kPa	-100.0 to 100.0 kPa	-0.100 to 1.000 MPa	
Set pressure range	10.0 to -105.0 kPa	-105.0 to 105.0 kPa	-0.105 to 1.050 MPa	
Withstand pressure	500 kPa	500 kPa	1.5 MPa	
Minimum display unit	0.1 kPa	0.1 kPa	0.001 MPa	
Applicable fluid	Air, inert gases and incombustible gases			
Power supply voltage	12 to 24 VDC $\pm 10\%$ , ripple (p-p) 10% or less (Protected against inverse connection)			
Current consumption	40 mA or less			
Switch output	NPN or PNP open collector output 2 outputs (selectable)			
Switch output	Max. load current	80 mA		
	Max. applied voltage	28 V (NPN output)		
	Residual voltage	2 V or less (at 80 mA load current)		
	Response time	2.5 ms or less (Chattering-proof function working: 20, 100, 500, 1000 or 2000 ms selected)		
	Short circuit protection	Provided		
Repeatability	$\pm 0.2\%$ F.S. $\pm 1$ digit			
Hys teresis	Hysteresis mode	0 to variable *1		
	Window comparator mode			
Analogue output	Voltage output	Output voltage (rated pressure range)	1 to 5 V $\pm 2.5\%$ F.S.	0.6 to 5 V $\pm 2.5\%$ F.S.
		Linearity	$\pm 1\%$ F.S.	
		Output impedance	approx. 1 k $\Omega$	
Display	3 1/2 digits, 7-segment display, colour display (red)			
Display accuracy	$\pm 2\%$ F.S. $\pm 1$ digit (at ambient temperature 25 $\pm 3$ °C)			
Indicator LED	LED is ON when output is ON. OUT1: Green OUT2: Red			
Environment	Enclosure	IP40		
	Ambient temperature range	Operation: -5 to 50 °C, Storage: -10 to 60 °C (No condensation or freezing)		
	Ambient humidity range	Operation, Storage: 35 to 85%RH (No condensation)		
	Withstand voltage	1000 VAC, 1 minute between terminals and housing		
	Insulation resistance	50 M $\Omega$ or more at 500 VDC between terminals and housing		
Temperature characteristics	$\pm 2\%$ F.S. (25 °C reference)			
Lead wire	Oil resistant vinyl cabtyre cable 5 cores $\phi$ 3.5, 2 m Sectional area of conductor: 0.15 mm <sup>2</sup> (AWG26) Outside diameter of insulator: 1.0 mm			
Standard	CE marked (EMC directive, RoHS directive), UL (CSA)			

\*1: If the applied voltage fluctuates around the set value, the hysteresis must be set to more than the fluctuation width. Otherwise, chattering will occur.

○Piping specifications

Model No.		M5	M5R	01	N01
Port size		M5×0.8	M5×0.8	R1/8 M5(0.8)	NPT1/8 M5(0.8)
Material of Wetted parts	Pressure sensing part	Silicone			
	Piping port	C3602 (Electro less nickel plating) O-ring: HNBR			
Weight	With lead wire and connector attached (5-core, 2 m)	55 g		63 g	
	Without lead wire and connector	15 g		23 g	

○Analogue output

Voltage output

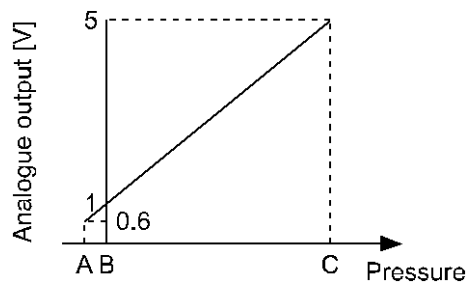

Range	Rated pressure range	A	B	C
Vacuum	0.0 to -101.0 kPa	-	0	-101 kPa
Compound	-100.0 to 100.0 kPa	-	-100 kPa	100 kPa
Positive pressure	-0.100 to 1.000 MPa	-0.1 MPa	0	1 MPa

## ■ Dimensions

### ○ Side piping

Z/ISE10(F)-M5-#-####

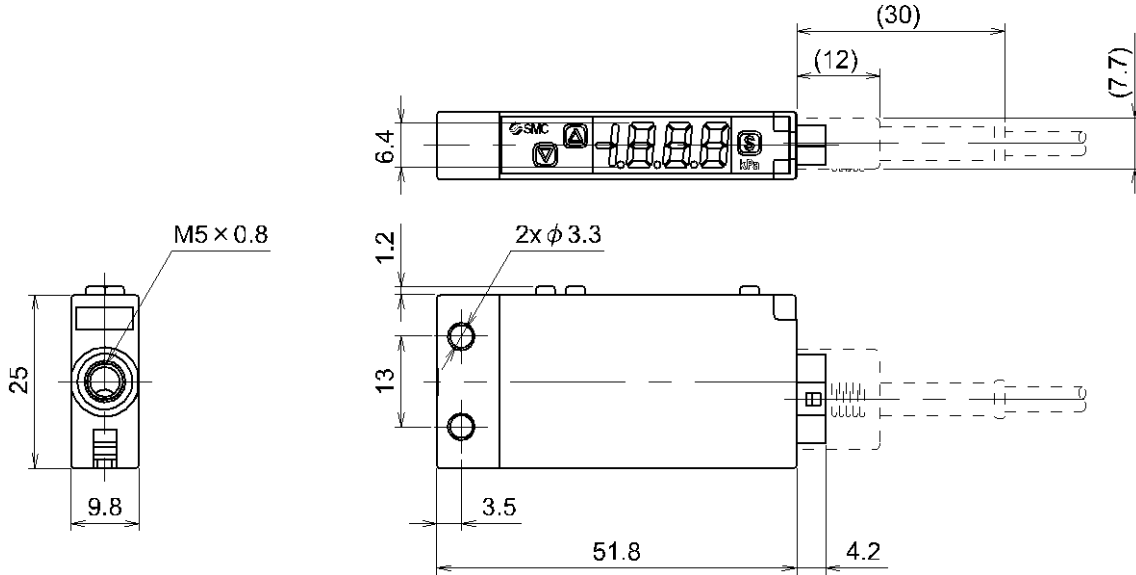

### ○ Rear piping

Z/ISE10(F)-M5R-#-####

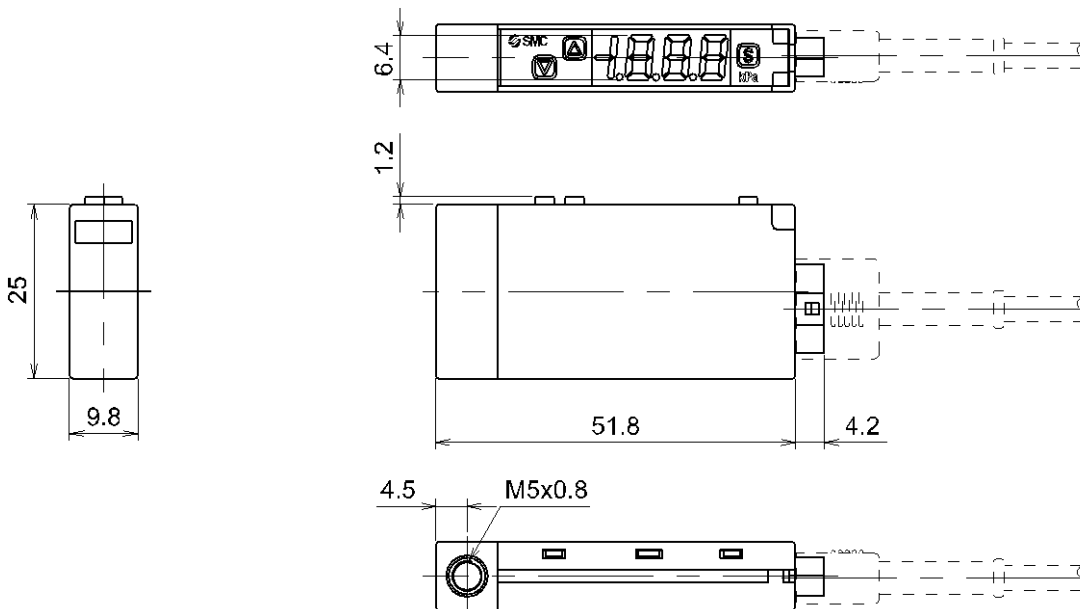

○Side piping  
 Z/ISE10(F)-01-#-####

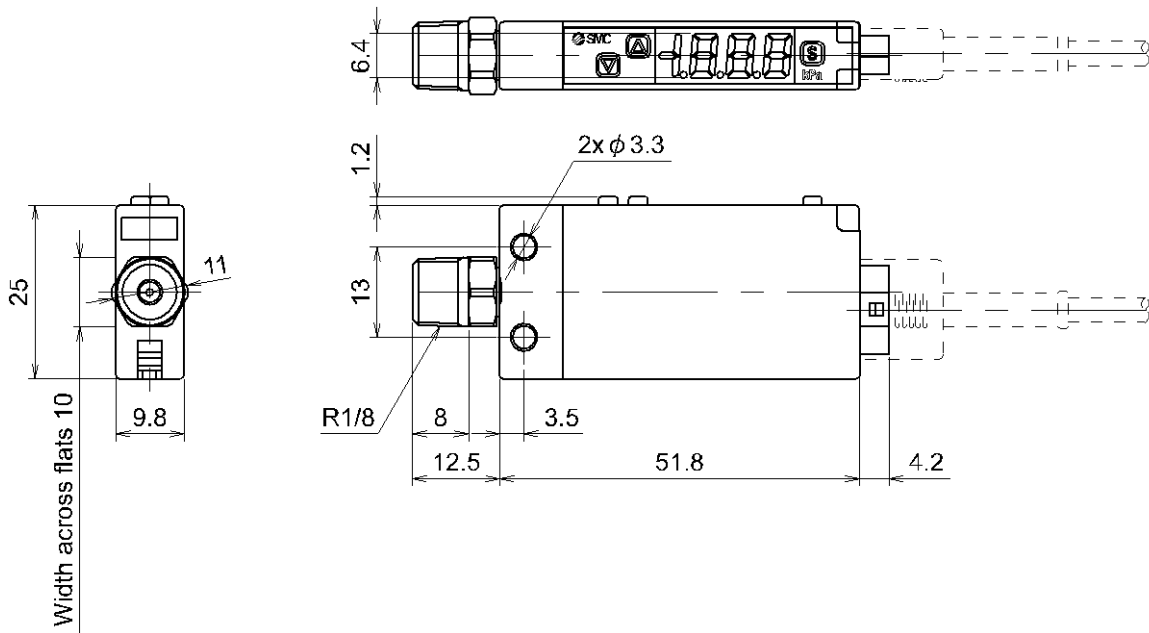

○Side piping  
 Z/ISE10(F)-N01-#-####

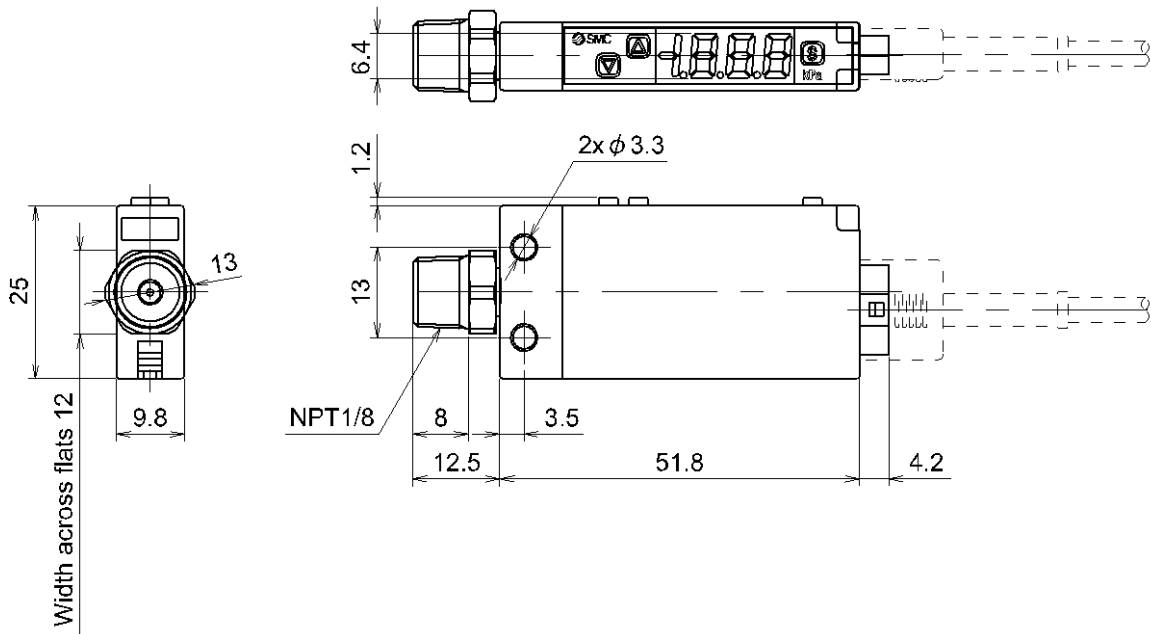

○ Panel mount side piping  
 Z/ISE10(F)-M5-#-### + ZS-39-B

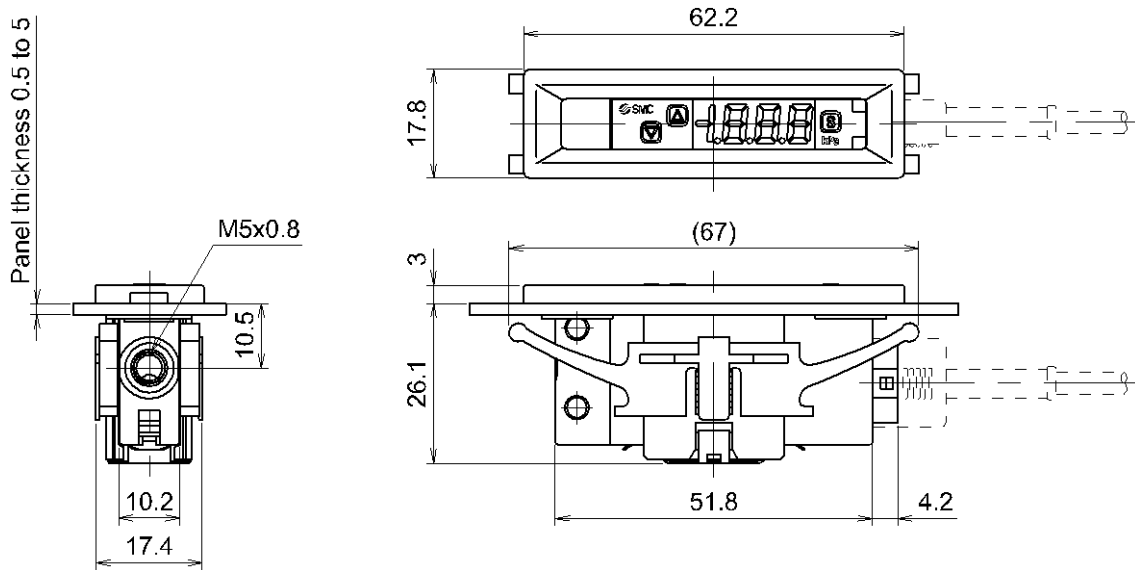

○ Panel mount rear piping  
 Z/ISE10(F)-M5R-#-### + ZS-39-B

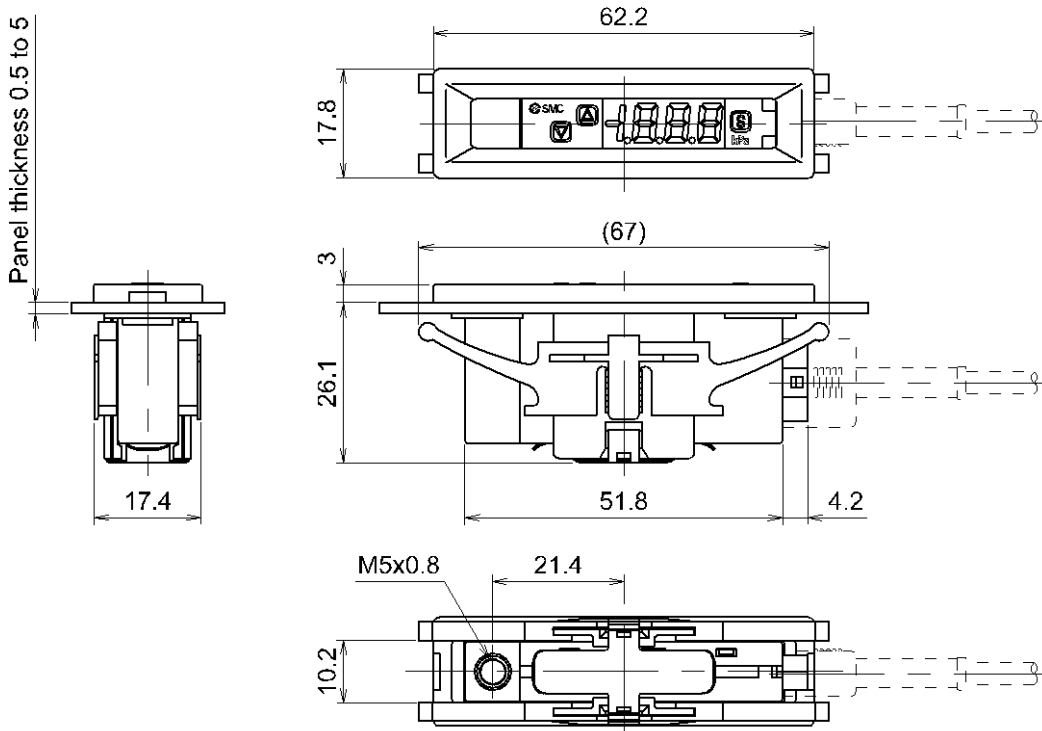

○Panel mount side piping + Front protective cover

Z/ISE10(F)-M5-#-##D#

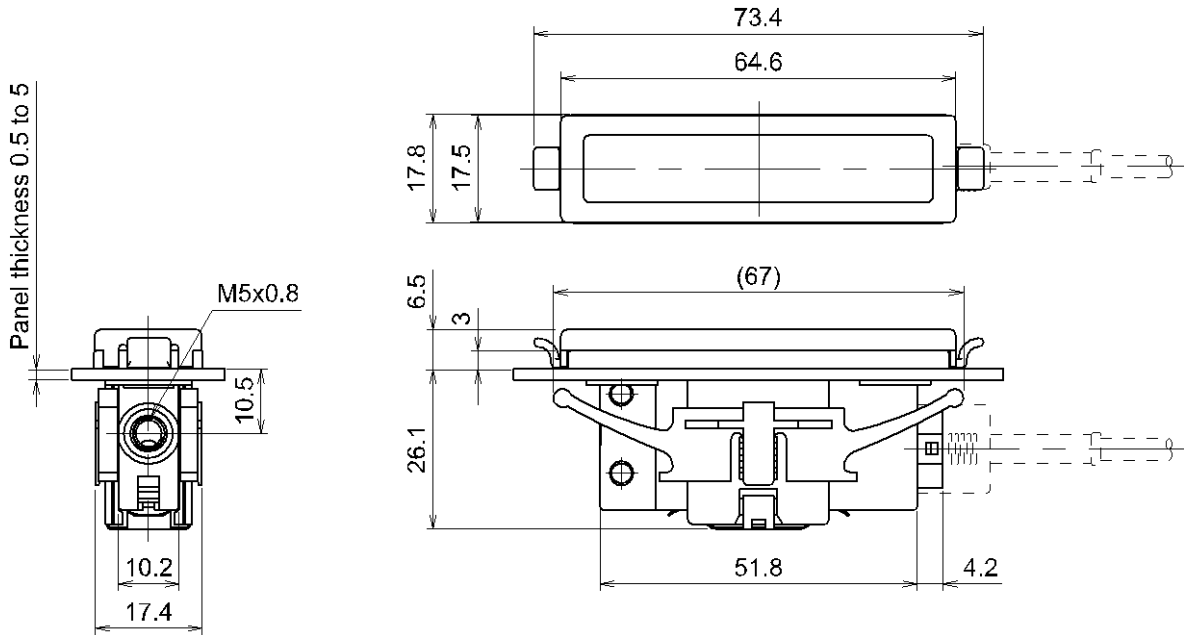

○Panel mount rear piping + Front protective cover

Z/ISE10(F)-M5R-#-##D#

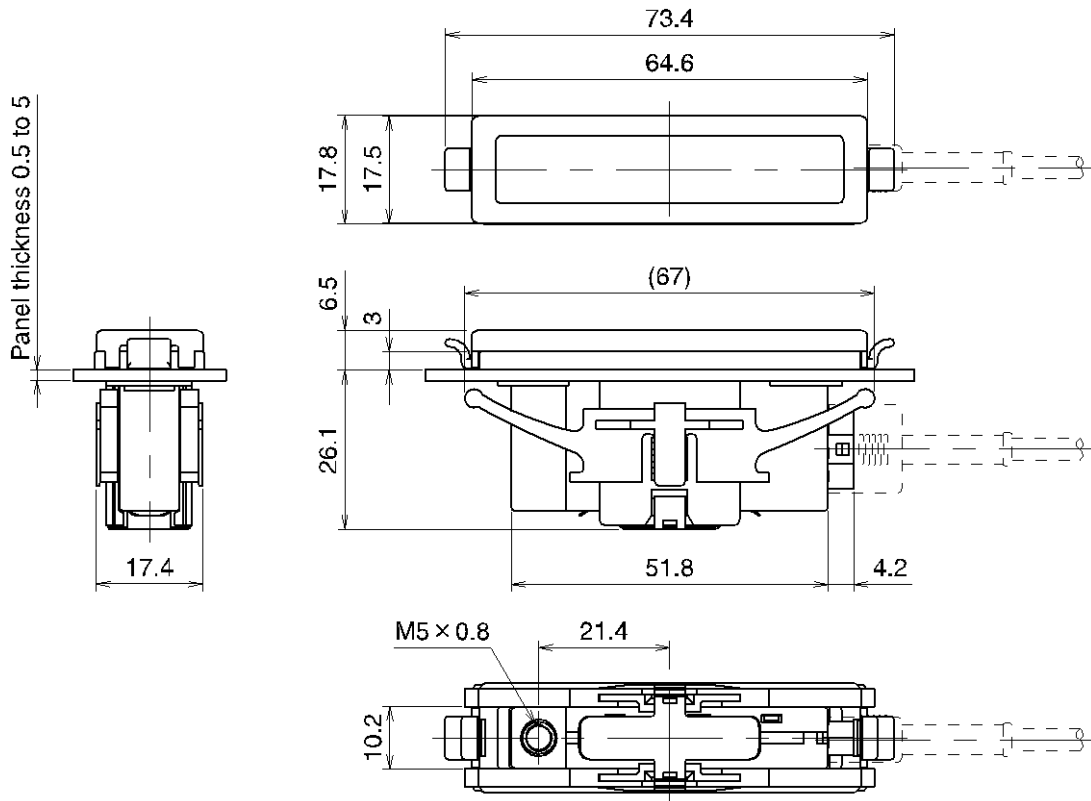

○Panel cut-out dimensions

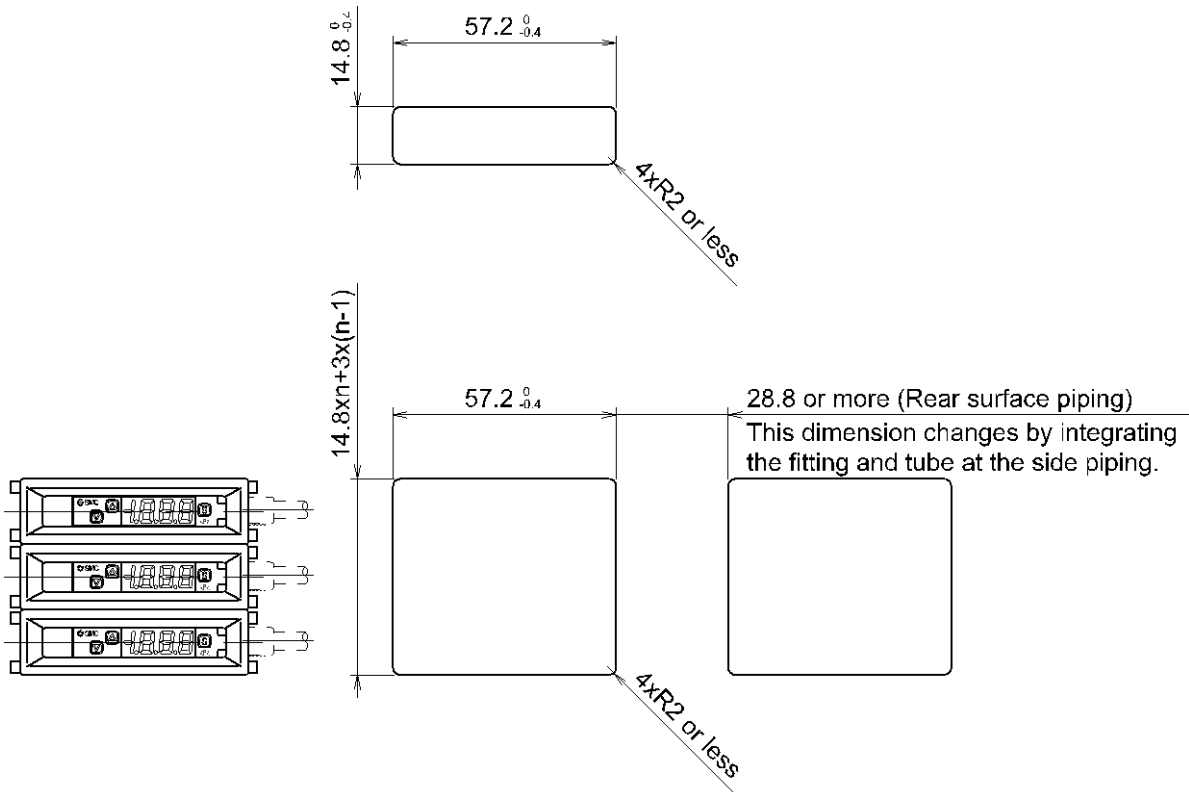

○DIN rail mounted side piping

Z/ISE10(F)-M5-#-##R#

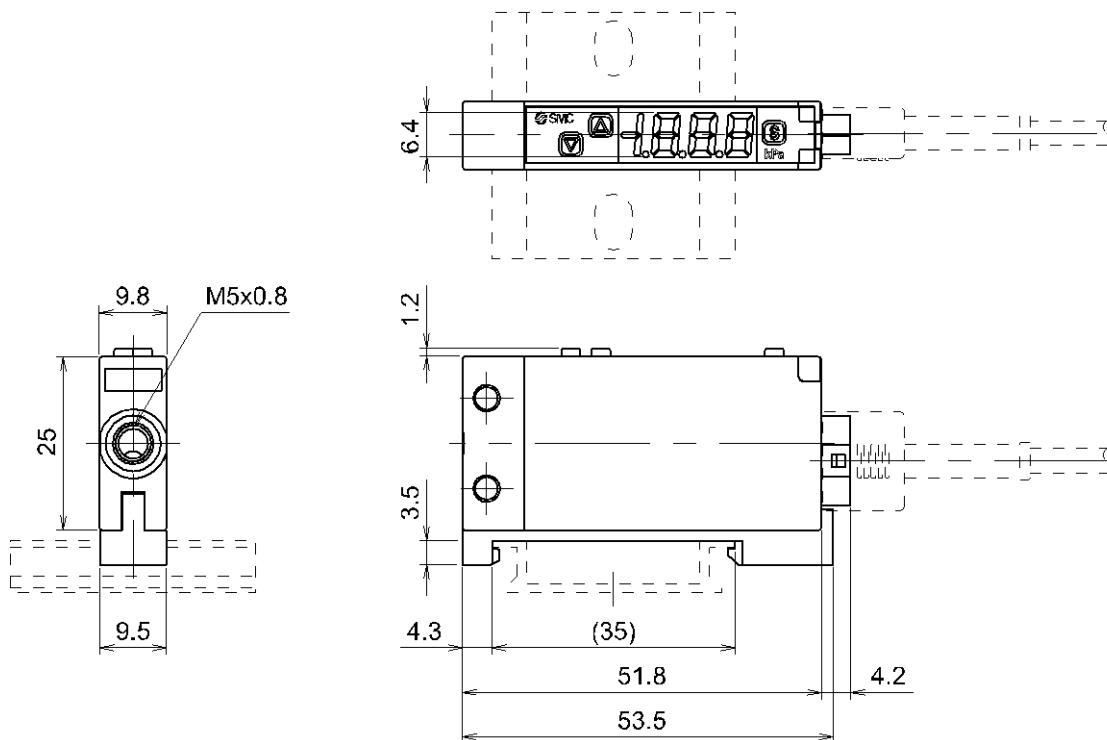

#### Revision history

A: Revision.  
B: Revision.  
C: Modified errors in text.  
D: Contents are added.  
E: Measurement laws are added.  
F: Contents are added.  
G: Contents revised in several places.  
H: Contents revised in several places. [June 2018]  
I: Contents revised in several places.  
[March 2020]  
J: Contents revised in several places.  
[February 2022]  
K: Contents revised in several places. [May 2024]

## SMC Corporation

Tel: + 81 3 5207 8249 Fax: +81 3 5298 5362  
URL <https://www.smcworld.com>

Note: Specifications are subject to change without prior notice and any obligation on the part of the manufacturer.  
© SMC Corporation All Rights Reserved

