



Operation Manual

PRODUCT NAME

Vacuum Manifold for fieldbus system

MODEL / Series / Product Number

ZKJ Series

SMC Corporation

Contents

Safety Instructions	2
1. How to Order	9
2. Summary of Product Parts	12
3. Installation	14
3.1. Installation	14
3.2. Air Supply	14
3.3. Piping	15
4. Solenoid Valve	17
5. SI Unit	18
6. Construction/Replacement Parts	20
6.1. Construction	20
6.2. Component Parts	21
6.3. Replacement Parts	21
7. Exploded View of Manifold/Replacement Parts	23
7.1. Exploded View of Manifold	23
7.2. Component Parts for Manifold	23
7.3. Replacement Parts	24
7.4. Manifold Option	25
7.5. How to Increase Manifold Stations	26
8. Maintenance	27
8.1. Maintenance	27
8.2. Replacement Procedure	28
9. Specifications	31
10. Pneumatic Circuit	34
11. Exhaust/Flow Rate Characteristics	35
11.1. Exhaust Characteristics/Flow Rate Characteristics (Representative value)	35
11.2. Release Flow Rate Characteristics (Representative value)	37
12. Limitations of Use	38
13. Troubleshooting	39



Safety Instructions

These safety instructions are intended to prevent hazardous situations and/or equipment damage. These instructions indicate the level of potential hazard with the labels of “**Caution**,” “**Warning**” or “**Danger**.” They are all important notes for safety and must be followed in addition to International Standards (ISO/IEC)^{*)}, and other safety regulations.

*1) ISO 4414: Pneumatic fluid power - General rules and safety requirements for systems and their components
ISO 4413: Hydraulic fluid power - General rules and safety requirements for systems and their components
IEC 60204-1: Safety of machinery - Electrical equipment of machines - Part 1: General requirements
ISO 10218-1: Robots and robotic devices - Safety requirements for industrial robots - Part 1: Robots
etc.



Danger

Danger indicates a hazard with a high level of risk which, if not avoided, will result in death or serious injury.



Warning

Warning indicates a hazard with a medium level of risk which, if not avoided, could result in death or serious injury.



Caution

Caution indicates a hazard with a low level of risk which, if not avoided, could result in minor or moderate injury.



Warning

1. The compatibility of the product is the responsibility of the person who designs the equipment or decides its specifications.

Since the product specified here is used under various operating conditions, its compatibility with specific equipment must be decided by the person who designs the equipment or decides its specifications based on necessary analysis and test results. The expected performance and safety assurance of the equipment will be the responsibility of the person who has determined its compatibility with the product. This person should also continuously review all specifications of the product referring to its latest catalog information, with a view to giving due consideration to any possibility of equipment failure when configuring the equipment.

2. Only personnel with appropriate training should operate machinery and equipment.

The product specified here may become unsafe if handled incorrectly. The assembly, operation and maintenance of machines or equipment including our products must be performed by an operator who is appropriately trained and experienced.

3. Do not service or attempt to remove product and machinery/equipment until safety is confirmed.

1. The inspection and maintenance of machinery/equipment should only be performed after measures to prevent falling or runaway of the driven objects have been confirmed.
2. When the product is to be removed, confirm that the safety measures as mentioned above are implemented and the power from any appropriate source is cut, and read and understand the specific product precautions of all relevant products carefully.
3. Before machinery/equipment is restarted, take measures to prevent unexpected operation and malfunction.

4. SMC products cannot be used beyond their specifications. They are not developed, designed, and manufactured to be used under the following conditions or environments. Use under such conditions or environments is not allowed.

1. Conditions and environments outside of the given specifications, or use outdoors or in a place exposed to direct sunlight.
2. Use for nuclear power, railways, aviation, space equipment, ships, vehicles, military application, equipment affecting human life, body, and property, combustion equipment, entertainment equipment, emergency shut-off circuits, press clutches, brake circuits, safety equipment, etc., and use for applications that do not conform to standard specifications such as catalogs and operation manuals.
3. Use for interlock circuits, except for use with double interlock such as installing a mechanical protection function in case of failure. Please periodically inspect the product to confirm that the product is operating properly.



Safety Instructions

Caution

SMC develops, designs, and manufactures products to be used for automatic control equipment, and provides them for peaceful use in manufacturing industries.

Use in non-manufacturing industries is not allowed.

Products SMC manufactures and sells cannot be used for the purpose of transactions or certification specified in the Measurement Act of each country.

The new Measurement Act prohibits use of any unit other than SI units in Japan.

Limited warranty and Disclaimer/Compliance Requirements

The product used is subject to the following “Limited warranty and Disclaimer” and “Compliance Requirements”. Read and accept them before using the product.

Limited warranty and Disclaimer

1. The warranty period of the product is 1 year in service or 1.5 years after the product is delivered, whichever is first.*2)
Also, the product may have specified durability, running distance or replacement parts. Please consult your nearest sales branch.
2. For any failure or damage reported within the warranty period which is clearly our responsibility, a replacement product or necessary parts will be provided.
This limited warranty applies only to our product independently, and not to any other damage incurred due to the failure of the product.
3. Prior to using SMC products, please read and understand the warranty terms and disclaimers noted in the specified catalog for the particular products.

***2) Vacuum pads are excluded from this 1 year warranty.**









A vacuum pad is a consumable part, so it is warranted for a year after it is delivered.

Also, even within the warranty period, the wear of a product due to the use of the vacuum pad or failure due to the deterioration of rubber material are not covered by the limited warranty



Compliance Requirements

1. The use of SMC products with production equipment for the manufacture of weapons of mass destruction (WMD) or any other weapon is strictly prohibited.
2. The exports of SMC products or technology from one country to another are governed by the relevant security laws and regulations of the countries involved in the transaction. Prior to the shipment of a SMC product to another country, assure that all local rules governing that export are known and followed.

Safety Instructions

 Warning	
 Disassembly prohibited	Do not disassemble, modify (including the replacement of board) or repair other than instructed in this manual. Otherwise, an injury or failure can result.
 Do not	Do not operate the product outside of the specifications. Do not use for flammable or harmful fluids. Fire, malfunction, or damage to the product can result. Please check the specifications before use.
 Do not	Do not use in an atmosphere containing flammable or explosive gases. Fire or an explosion can result. The product is not designed to be explosion proof.
 Do not	Do not use the product in a place where static electricity is a problem. Otherwise failure or malfunction of the system can result.
 Do not	Do not cut off the power and compressed air supplied to this product while it is operating. Otherwise it can cause injury due to dropping of workpieces or damage to the system.
 Instruction	If using the product in an interlocking circuit - Provide a double interlocking system, for example a mechanical system. - Check the product for proper operation. Otherwise malfunction can result, causing an accident.
 Instruction	The following instructions must be followed during maintenance - Turn off the power supply - Stop the air supply, exhaust the residual pressure in piping and verify that the air is released before performing maintenance work. It may cause an injury.

⚠ Caution

 Do not touch	<p>Do not touch the terminals and connectors while the power is on.</p> <p>Otherwise electric shock, malfunction or damage to the switch can result.</p>
 Instruction	<p>Perform sufficient trial run.</p> <p>Otherwise, injury or damage to the system can result due to suction failure depending on the conditions of the suction of the workpiece or the pressure switch settings.</p> <p>Perform sufficient verification before using this product.</p>
 Instruction	<p>After maintenance is complete, perform appropriate functional inspections and leak test.</p> <p>Stop operation if the equipment does not function properly or there is leakage of fluid.</p> <p>If there is leakage from parts other than the piping, the product might be broken.</p> <p>Cut off the power supply and stop the fluid supply.</p> <p>Do not supply fluid if there is leakage.</p> <p>Safety cannot be assured in the case of an unexpected malfunction.</p>

■ Handling Precautions

Follow the instructions given below for selecting and handling of the vacuum manifold.

- The instructions on design and selection (installation, wiring, environment, adjustment, operation, piping, maintenance, etc.) described below must be followed.

*Product specifications

- Be sure to check the specifications.

This product is designed only for use in compressed air systems (including vacuum). Do not operate at pressures, temperatures, etc., beyond the range of specifications, as this can cause damage or malfunction. (Refer to the specifications)

We do not guarantee against any damage if the product is used outside of the specification range.
- It is recommended to use compressed air which purity class is 2:6:3 of ISO8573-1:2010.

If compressed air containing condensate is used, install an air dryer or drain catch before the filter and perform draining regularly.

If draining is not performed regularly and condensate enters the secondary side, it can cause operating failure of pneumatic equipment.

When it is difficult to control drainage, the use of a filter with an auto drain is recommended.
- The applicable fluid is air.

Do not use a fluid containing chemicals, synthetic oils including organic solvent, salt and corrosive gases.

Otherwise, damage to the vacuum unit and malfunction can result.

Check the details of the specifications before use.
- Use the specified operating pressure.

Otherwise it can cause damage to the vacuum unit or inability to adsorb correctly.

The parts around the vacuum port of this product are designed to be used with vacuum pressure.
- Reserve a space for maintenance.

Design the system allowing the required space for maintenance.
- Use the specified voltage.

Otherwise failure or malfunction can result.
- Do not exceed the specified maximum allowable load.

Otherwise it can cause damage or shorten the life of the product.
- Design the product to prevent reverse current when the circuit is opened or the product is forced to operate for operational check.

Reverse current can cause malfunction or damage the product.

- Do not use the vacuum unit to drive an actuator such as a cylinder and fill the pressure vessel with compressed air (when release pressure is constantly applied).

Otherwise this can result in damage or reduced performance. The service life (based on SMC's test condition) is 10 million times. When using the product with exhaust sealing valve to drive an actuator such as a cylinder, gripper and etc, the service life is decreased due to the piping condition of the vacuum port. Reference value is as follows,

10 million times at piping volume 5,890mm³(ø8x5x300mm), 5 million times at piping volume 157000mm³(ø8x5x8,000mm).

- Cannot be used for use as an emergency shutoff valve, etc.

The valves listed in this catalog are not designed for safety applications such as an emergency shutoff valve. If the valves are used in such applications, other reliable safety assurance measures should also be adopted.

●Product handling

* Installation

- Tighten to the specified tightening torque.

If the tightening torque is exceeded, the product, the mounting screws and brackets can be broken. Insufficient torque can cause displacement of the product and loosening of the mounting screws.

- Do not drop, hit or apply excessive shock to the product.

Otherwise damage to the internal parts of the product can result, causing malfunction.

- When carrying the vacuum manifold, make sure that the connections are not stressed.

Otherwise, the damage to connections can result. In addition, some combinations of the manifold may be very heavy, so use more than one person to carry or install the unit.

- Never mount a product in a location that will be used as a foothold.

The product may be damaged if excessive force is applied by stepping or climbing onto it.

- Eliminate any dust left in the piping by using a blast of air before connecting the piping to the product.

It will cause failure or malfunction.

- If the fluid may contain foreign matter, install and connect a filter or mist separator to the inlet.

It will cause failure or malfunction.

* Wiring (Including connecting/disconnecting of the connectors)

- Do not pull hard on the lead wire, or lift the product by holding the lead wires of the solenoid valve or the pressure sensor.

Otherwise damage to the solenoid valve or the internal parts of the pressure sensor can result, causing malfunction or causing the connector to come off.

- Avoid repeatedly bending, stretching or applying a heavy object or force to the lead wire.

- Wire correctly.

Incorrect wiring can cause malfunction or breakage of the SI Unit, control unit, solenoid valve or the pressure sensor.

- Do not perform wiring while the power is on.

Otherwise damage to the SI Unit, control unit, solenoid valve or the pressure sensor can result, causing malfunction.

- Do not route wires and cables together with power or high voltage cables.

Route the wires (piping) of the solenoid valve or the pressure switch/sensor separately from power or high voltage cables in order to avoid noise or surge entering the signal line from the power or high voltage line.

- Confirm proper insulation of wiring.

Poor insulation (interference with other circuits, poor insulation between terminals etc.) can apply excessive voltage or current to the SI Unit, control unit, solenoid valve or the pressure sensor, causing damage.

- Take appropriate measures against noise, such as using a noise filter, when the fieldbus system is incorporated into equipment.

Otherwise, noise can cause malfunction.

*Operating environment

- IP65 enclosure: The protection structure against solid foreign objects is dust-tight type and the protection structure against water-jet-proof type.
Dust-tight means that no dust can enter the inside of the equipment.
Water-jet-proof means that the product is not adversely affected by direct water jets from any direction. That is, even when direct water jets are applied to the product for 3 minutes by means of the pre-determined method, there is no water entry that hinders the correct operation inside the equipment. Be sure to take appropriate protective measures if the product is to be used in an environment where it will be constantly exposed to water or fluids other than water splash. In particular, the product cannot be used in environments where oils, such as cutting oil or cutting fluid, are present.
- When using high-noise reduction silencer, keep the exhaust port of the silencer from coming in direct contact with water or other liquids.
It will cause failure or malfunction.
- Select the proper type of protection according to the environment of operation.
IP65 protection is achieved when the following conditions are met:
 - (1) The units are connected properly with fieldbus cable with M12, M8 connector and power cable with M12, M8 connector.
 - (2) Suitable connecting of connectors for supply valve and release valve assembly, pressure sensor assembly and the control unit.
 - (3) Suitable mounting of SI Unit, control unit, vacuum units, etc.
 - (4) Be sure to fit a seal cap on any unused connectors.
- Do not use in an environment where corrosive gases, chemicals, sea water, water or steam are present.
These may cause failure or malfunction.
- Do not use the product in a place where the product could be splashed by oil or chemicals.
If the product is to be used in an environment containing oils or chemicals such as coolant or cleaning solvent, even for a short time, the solenoid valve or pressure switch/sensor may be adversely affected (damage, malfunction, or hardening of the lead wires).
- Do not use in an area where surges are generated.
When there are machines or equipment that generate large surge near the pressure switch/sensor (magnetic type lifter, high frequency inductive furnace, motor, etc.), this can result in deterioration and damage of the internal elements. Take measures against the surge sources, and prevent the lines from coming into close contact.
- Do not use a load which generates surge voltage.
When a surge-generating load such as a relay or solenoid is directly driven, use the product with a surge absorbing element built-in.
- The product is CE/UKCA marked, but not immune to lightning strikes, so take measures against lightning strikes. Be aware of excessive surrounding noise.
The product is CE/UKCA marked and has passed the EMC test, but excessive noises in the surrounding area may affect the functioning of the product.
- Mount the product in a location that is not affected by vibration or impact.
It will cause failure or malfunction.
- Do not let foreign matter, such as wire debris, get inside the product.
In order to avoid failure and malfunction, do not let foreign matter, such as wire debris, get inside the product.
- Do not use the product in an environment that is exposed to temperature cycle.
Heat cycles other than ordinary changes in temperature can adversely affect the inside of the product.
- Do not expose the product to direct sunlight.
If using in a location directly exposed to sunlight, protect the product from the sunlight.
Failure or malfunction may occur.
- Keep within the specified operating fluid and ambient temperature range.
Operation under low temperature may lead to damage or operation failure due to frozen moisture in the fluid or air.
Protection against freezing is necessary. Mounting of an air dryer is recommended for elimination of drainage and water.
Avoid abrupt temperature changes even within the specified temperature range.
- Do not use in a location where the product is exposed to radiant heat from surrounding heat sources.
Insufficient air quality may cause operation failure.

* Adjustment and Operation

- If using the product to detect very small pressures, warm up the product for 10 to 15 minutes first.
There will be a drift on the display of approximately 1% for 10 minutes after the power supply is turned on.
- Perform settings suitable for the operating conditions.
Incorrect setting can cause operation failure.
For details of each setting, refer to the Operation Manual of the SI Unit for vacuum manifold.
- Please refer to the PLC manufacturer's manual, etc. for details of the SI unit programming and addresses.
The programming content related to the protocol is designed by the manufacturer of the PLC used.

*Piping

- Preparation before piping
Before piping, perform air blow (flushing) or cleaning to remove any cutting chips, cutting oil, dust, etc. from the piping.
- Wrapping of pipe tape
When installing piping or a tube fitting into a port, prevent cutting chips and sealant material from getting inside the product.
If a sealant tape is used, leave 1 thread exposed at the end of threads.
- When connecting tubing, consider factors such as changes in the tubing length due to pressure, and allow a sufficient margin.
Otherwise, it can damage the fitting and cause the tube to come off. Refer to Fittings & Tubing Precautions from 1 to 4 shown in Best Pneumatics 6 on SMC's website (URL <https://www.smcworld.com>) for the recommended piping conditions.

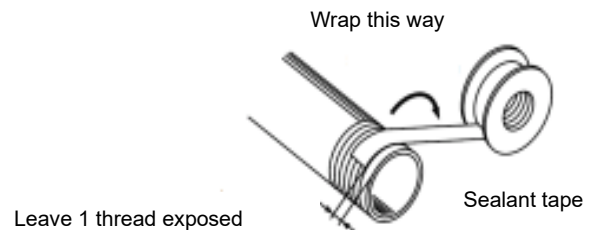

*Maintenance

- Turn off the power supply, stop the supplied air, exhaust the residual compressed air in the piping and verify the release of air before performing maintenance.
There is a risk of unexpected malfunction of component.
- Perform regular maintenance and inspections.
There is a risk of unexpected failure of components due to the malfunction of equipment and machinery.
- After maintenance is complete, perform appropriate functional inspections.
Stop operation if the equipment does not function properly.
Otherwise, safety is not assured due to an unexpected malfunction or incorrect operation.
- Perform draining regularly.
If condensate enters the secondary side, it can cause operating failure of pneumatic equipment.
- Do not use solvents such as benzene, thinner etc. to clean the product.
This may damage the surface of the body or erase the markings on the body.
Use a soft cloth to remove stains. For heavy stains, use a cloth soaked with diluted neutral detergent and fully squeezed, then wipe up the stains again with a dry cloth.

1. How to Order

Vacuum Manifold

ZZKJ 04 - FAN - L8
 (1) (2) (3)

(1) Number of Manifold Stations Note 1) 2) 3)

Symbol	Manifold Stations	Single unit stations
04	4 stations	Max. 4 stations
08	8 stations	Max. 8 stations
12	12 stations	Max. 12 stations
16	16 stations	Max. 16 stations

Note 1) The product outline is every four stations manifold. Be sure that the total number of the vacuum units, positive pressure units and the blanking plates is equal to the manifold stations.

Note 2). The manifold model number cannot be ordered alone.

Note 3) The vacuum unit and positive pressure unit can be increased by exchanging the blanking plate, and also decreased for maintenance. Refer to [How to Increase Manifold Stations](#) on page 26.

(2) SI Unit

Symbol	Protocol
DAN	EtherCAT®
EAN	EtherNet/IP™
FAN	PROFINET
KAN	IO-Link

(3) U-side end plate and supply (P) port

Symbol	Type
L8	ø8 One-touch fitting elbow
LN9	ø5/16" One-touch fitting elbow

Vacuum Unit

ZKJ 07 C8 H □ - A 5 U - T1 - □
 (1) (2) (3) (4) (5)(6) (7) (8) (9)

Remains blank when no option is selected.

(1) Nominal Nozzle Size

Symbol	Nominal size
07	ø0.7
10	ø1.0
12	ø1.2
15	ø1.5

(2) Vacuum (V) port, Supply (P) port

Symbol	Standard	Vacuum (V) port	Supply (P) port
C6	Metric	ø6	Plug
C8		ø8	
N7	Inch	ø1/4"	
N9		ø5/16"	
C6U	Metric	ø6	ø6 <small>Note 4)</small>
C8U		ø8	
N7U	Inch	ø1/4"	ø1/4" <small>Note 4)</small>
N9U		ø5/16"	

Note 4) When selecting "Plug for individual supply" for options (8) or increasing the flow rate of supply air, select Supply port.

(3) Exhaust (EXH) port

Symbol	Exhaust type
H	High-noise reduction silencer exhaust
P	Port exhaust ^{Note 5)}

Note 5) Port size of exhaust port; mm: ø8, inch: ø5/16"

(4) Exhaust sealing valve ^{Note 6)}

Symbol	Specification
Nil	-
V	Exhaust sealing valve

Note 6) When "15" for (1) nominal nozzle size is selected, 'V' cannot be available.

(5) Combination of Supply Valve and Release Valve ^{Note 7)}

Symbol	Supply valve	Release valve
A	N.C.	N.C.
E	N.O.	N.C.

Note 7) Be sure to check the factory default setting for the supply valve of the SI unit. Change the SI unit settings in accordance with the selected supply valve.

(6) Rated Voltage

Symbol	Voltage
5	24 VDC

(7) Light/surge voltage suppressor and common specification

Symbol	Light	Surge voltage suppressor	Polarity
U	●	●	Non-polar

(8) Pressure sensor ^{Note 8) 9)}

Symbol	Specification
T1	-100 to 100 [kPa]
T2	-100 to 200 [kPa]

Note 8) When "Nil" is selected for (4) exhaust sealing valve, T1 is required. When "V" is selected, T2 is required.

Note 9) The factory default setting for the pressure sensor specification of the SI unit is T1. Change the SI unit settings in accordance with the specifications of the selected pressure sensor.

(9) Option ^{Note 10)}

Symbol	Type
Nil	Without option
E	Release flow control valve Screwdriver operation type long lock nut
M	Plug for individual supply ^{Note 11) 12)} (Blocking the air supply passage to the D side)
R	Manual override for residual pressure release ^{Note 13)}
Y	Vacuum (V) port release to atmosphere type ^{Note 14) 15)} (Check valve: 1 pc.)

Note 10) When more than one option is selected, list the option symbols in alphabetical order. (Example -EM)

Note 11) The supply (P) port for vacuum manifold is mounted only on the U side. When option M is selected, select the supply (P) port for (2) on the D side of the vacuum unit and positive pressure unit where the plug for individual supply is mounted. For detail, refer to [Manifold Option](#) on page 25.

Note 12) The plug for individual supply is mounted on the first station to block the air supply passage to the D side. Option M can be selected after second station.

Note 13) Manual override to release vacuum (V) port to atmosphere. When option R is selected, option Y cannot be used together.

Note 14) When option Y is selected, the energy saving function is not available. When the vacuum generation is stopped, the vacuum (V) port is released to the atmosphere.

Note 15) When option Y is selected, "V" for (4) exhaust sealing valve cannot be selected.

■ Positive pressure Unit

ZKJ 1V C6 P - 1 5 U -

(1) (2) (3) (4)(5)(6) (7)

Remains blank when no option is selected.

(1) Unit type ^{Note 16)}

Symbol	Type
1V	Positive Pressure Unit

Note 16) When a positive pressure unit is used in the SI unit's default settings, the diagnostic information (pressure sensor disconnection) is issued. Change the SI unit settings in accordance with the selected type.

(2) Output A(4), B(2) port, Supply P(1) port

Symbol	Standard	Vacuum (V) port	Supply P(1) port
C6	Metric	ø6	Plug
C8		ø8	
N7	Inch	ø1/4"	
N9		ø5/16"	
C6U	Metric	ø6	ø6 ^{Note 17)}
C8U		ø8	ø8 ^{Note 17)}
N7U	Inch	ø1/4"	ø1/4" ^{Note 17)}
N9U		ø5/16"	ø5/16" ^{Note 17)}

Note 17) When selecting "Plug for individual supply" for options (8) or increasing the flow rate of supply air, select Supply port.

(3) Exhaust E(3/5) port

Symbol	Exhaust type
P	Port exhaust ^{Note 18)}

Note 18) Port size of exhaust port; mm: ø8, inch: ø5/16"

(4) Type of actuation

Symbol	Type	
1	2-position	Single
2		Double
A	4-position dual 3-port	N.C./N.C.

(5) Rated Voltage

Symbol	Voltage
5	24 VDC

(6) Light/surge voltage suppressor and common specification

Symbol	Light	Surge voltage suppressor	Polarity
U	●	●	Non-polar

(7) Option

Symbol	Type
Nil	Without option
M	Plug for individual supply ^{Note 19) 20)} (Blocking the air supply passage to the D side)

Note 19) The supply (P) port for vacuum manifold is mounted only on the U side. When option M is selected, select the supply port for (2) on the D side of the vacuum unit and positive pressure unit where the plug for individual supply is mounted. For detail, refer to [Manifold Option](#) on page 25.

Note 20) The plug for individual supply is mounted on the first station to block the air supply passage to the D side. Option M can be selected after second station.

2. Summary of Product Parts

Manifold

Control Unit

Blanking plate

SI Unit

(EX260-VPN1)
(EX260-VEN1)

Fieldbus interface connector
(BUS OUT/Port2)

Fieldbus interface connector
(BUS IN/Port1)

Power supply connector
(PWR)

Supply (P) port

4 x M6 Mounting hole

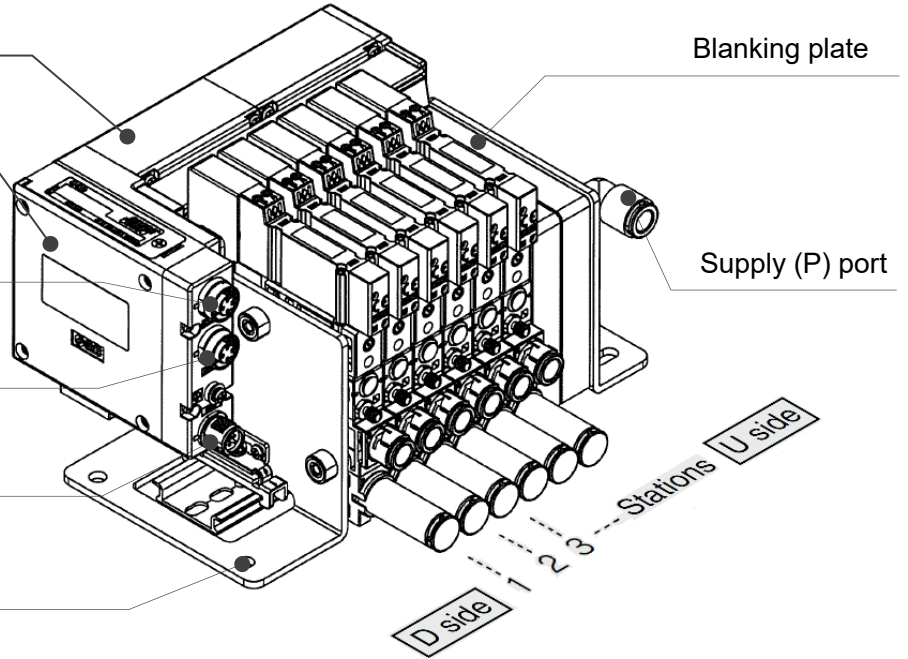

SI Unit

(EX260-VIL1)

Communication /
Power supply connector

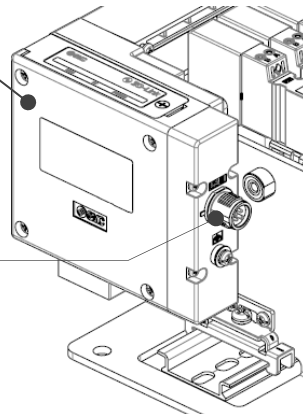

SI Unit

(EX260-VEC1)

Communication connector
(ECAT IN)

Communication connector
(ECAT OUT)

Power supply connector
(PWR IN)

Power supply connector
(PWR OUT)

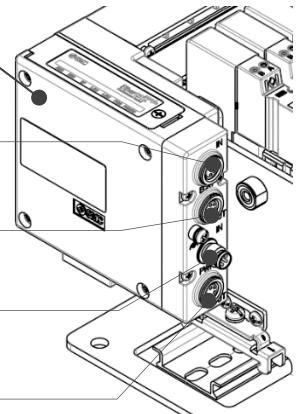

■ Vacuum Unit

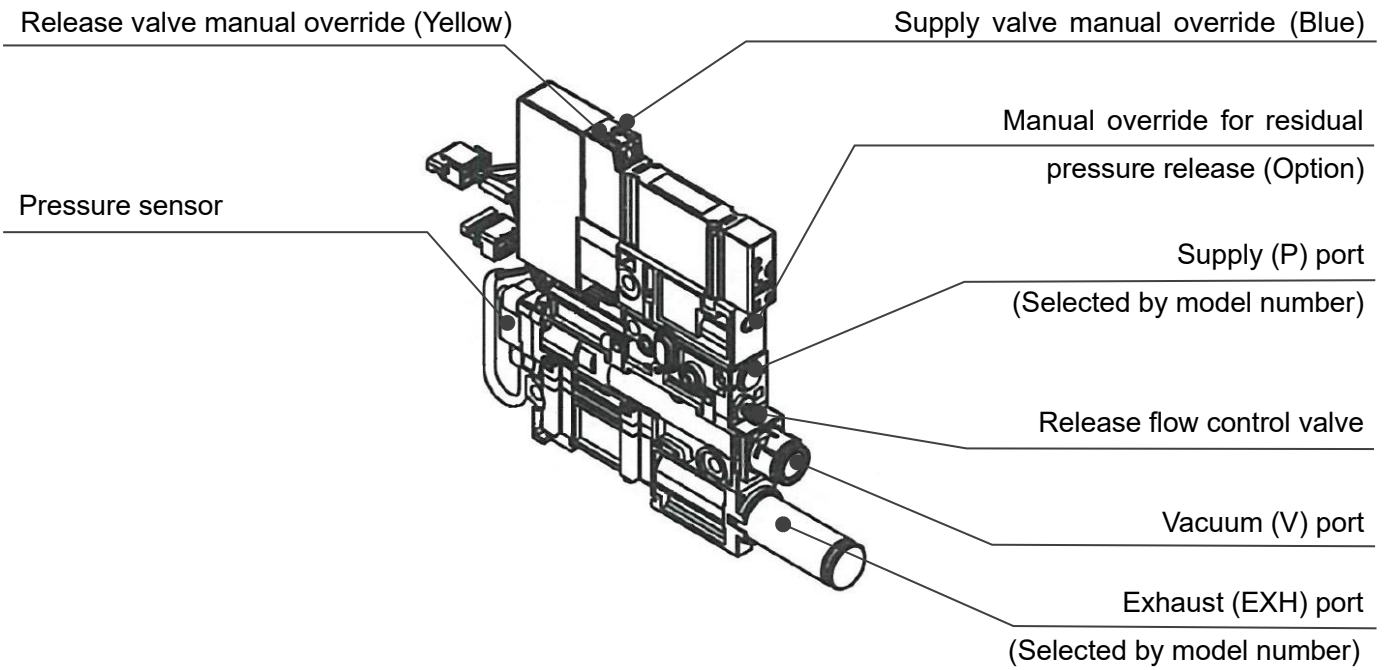

■ Positive pressure Unit

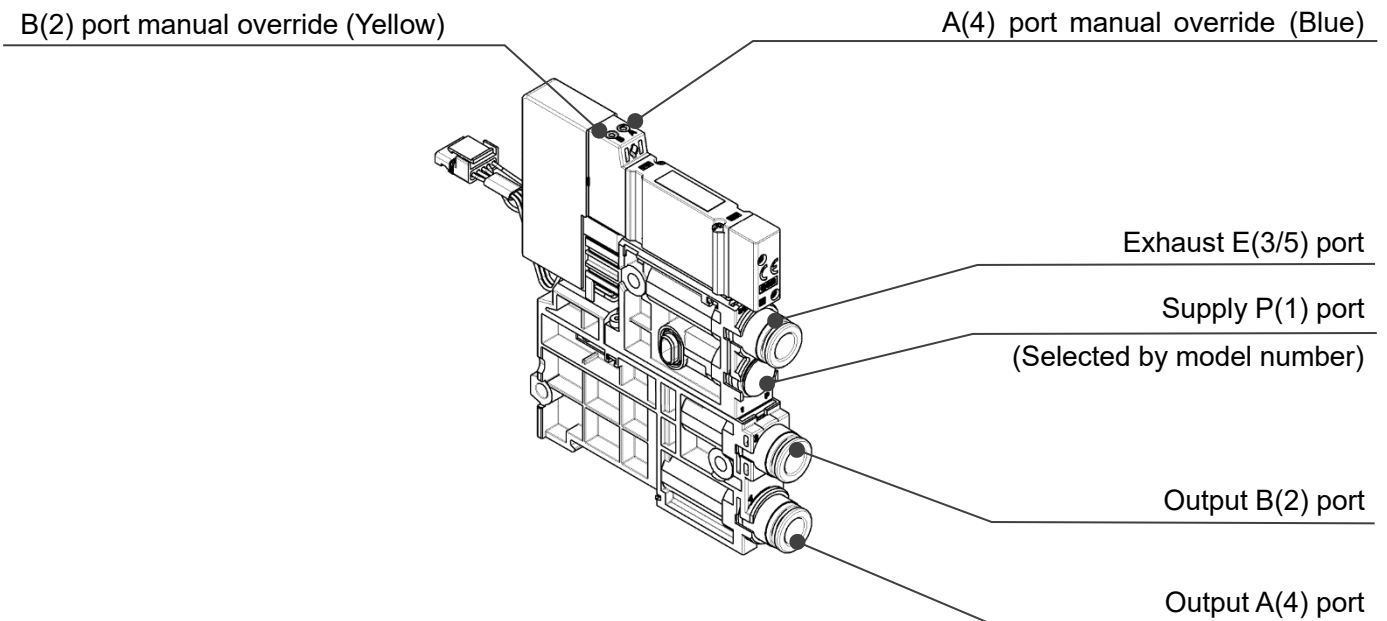

3. Installation

3.1. Installation

Mount and tighten the manifold using the holes in the end plate (4 x M6).

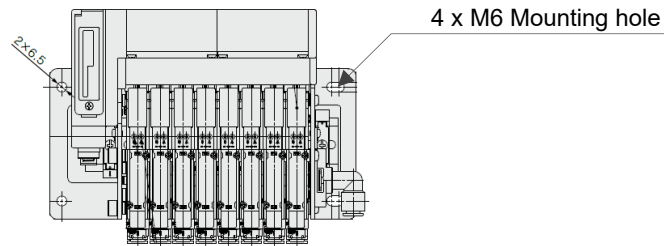

■ Precaution

1. Do not drop, hit, or apply excessive impact to the product when handling it.
Even if the body looks undamaged, the internal components may be damaged, leading to a malfunction.
2. Load to the vacuum manifold
Do not lift the product by holding the one touch fitting or High-noise reduction silencer. This may cause damage to the body.
The vacuum manifold is made of resin; therefore, do not apply load to the port after mounting. Prevent any kind of operation which generates moment as this may cause reduced performance or damage to the body.
3. Installation
Manifold can be mounted onto the floor using M6 holes on the end plate. The DIN rail installed in the product is used for connecting the vacuum unit, etc. Do not use mounting holes of the DIN rail to mount the product.
4. Ensure sufficient space for maintenance activities
When installing the products, allow access for maintenance.
5. Ventilation
Provide ventilation when using a vacuum manifold in a confined area, such as in a closed control panel.
For example, install a ventilation opening, etc., in order to prevent pressure from increasing inside of the confined area and to release the heat generated by the valve.

3.2. Air Supply

■ Use clean air

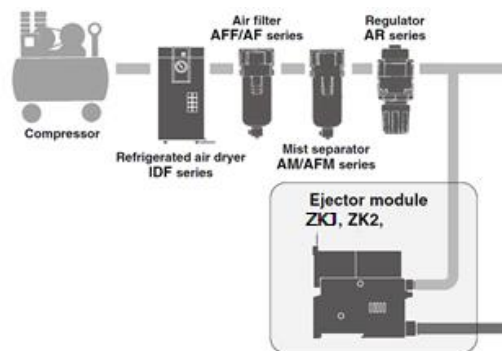

1. Using compressed air which contains chemicals, synthetic oils containing organic solvents, salts or corrosive gases, etc. can cause damage or malfunction. Do not use compressed air containing toxic impurities.
2. If the compressed air contains excessive drainage or carbon powder, it can stick to the vacuum generating part (the nozzle diffuser) or inside of the solenoid valve or the pressure sensor and cause deterioration of the performance or operation failure.

3. Quality of supply air

It is recommended to use compressed air which purity class is 2:6:3 of ISO8573-1:2010.

Supply air containing foreign matter, water, oil or condensate, etc. can cause malfunction of supply and release valve.

It is recommended that an air filter and a mist separator are connected to the upstream side of the vacuum manifold to prevent foreign matter (drainage) from entering into the product, and perform periodic maintenance of the mist separator to keep supply air quality.

The purity class of compressed air quality based on ISO8573-1:2010

2 : 6 : 3

Solid particle				Moisture		Oil	
Class	Max number of particles per m ³ Particle size d (μm)			Class	Pressure dew point (°C) at air pressure of 0.7 MPa	Class	Oil concentration (mg/m ³)
	0.1 < d ≤ 0.5	0.5 < d ≤ 1.0	1.0 < d ≤ 5.0				
1	≤ 20,000	≤ 400	≤ 10	1	≤ -70	1	≤ 0.01
2	≤ 400,000	≤ 6,000	≤ 100	2	≤ -40	2	≤ 0.1
3	Not specified	≤ 90,000	≤ 1,000	3	≤ -20	3	≤ 1
4	Not specified	Not specified	≤ 10,000	4	≤ +3	4	≤ 5
5	Not specified	Not specified	≤ 100,000	5	≤ +7		
				6	≤ +10		

3.3. Piping

The sizes of each port and the operating pressure range are as follows:

Use the product within the specified operating pressure range. Operation with a pressure exceeding the maximum operating pressure leads to breakage of the product. The parts around the vacuum port of the vacuum unit are designed to be used with vacuum pressure.

Vacuum Unit

Port	Size		Operating pressure range [MPa]
	Metric	Inch	
P (U-side end plate)	ø8	ø5/16"	0.3 to 0.5
P (Vacuum unit) ^{Note 1) 2)}	ø6	ø1/4"	
V	ø6, ø8	ø1/4", ø5/16"	-
EXH (Port exhaust)	ø8	ø5/16"	-

Positive pressure Unit

Port	Size		Operating pressure range [MPa]
	Metric	Inch	
P (U-side end plate)	ø8	ø5/16"	0.3 to 0.5
P (Positive pressure unit) ^{Note 1)}	ø6, ø8	ø1/4", ø5/16"	
A, B	ø6, ø8	ø1/4", ø5/16"	-
EXH	ø8	ø5/16"	-

-: Not applicable

Note 1) P port (Vacuum unit and Positive pressure unit) is available when selecting for model number. P ports (U-side End plate and each unit) are connected inside.

Note 2) For an adequate performance, the number of stations when operated simultaneously depends on the nozzle diameter. Refer to [Maximum Number of Manifold Stations that Can Operate Simultaneously](#) on page 32.

■ Precautions

1. **When piping to the product, be careful not to confuse a vacuum port with an exhaust port. Otherwise this can result in damage or reduced performance. Apply compressed air after confirming that the piping is connected correctly.**
2. For maintenance and inspection purposes, ensure to install the residual pressure release system when piping.
V port is released to atmosphere when performing the manual override for residual pressure release (option). Please perform after ensuring measured are in place to prevent the workpieces from dropping, etc.

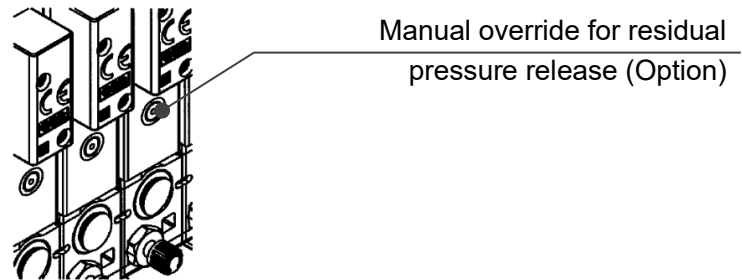

3. Insertion of the tube

- (1) Cut the tube perpendicularly, being careful not to damage the external surface. Use SMC's tube cutter TK-1, 2 or 3 for cutting. Do not cut the tube with pliers, nippers, scissors, etc. If the tube is cut by any tools other than a tube cutter, the cut surface of the tube will be slanted or flat, making it difficult to be connected securely, causing the tube to come off or air leakage after the tube is connected. Also, allow a sufficient margin of tube length.
- (2) Hold the tube and push it in slowly, inserting it securely all the way into the fitting.
- (3) After inserting the tubing, pull on it gently to confirm that it will not come out. If it is not installed securely all the way into the fitting, problems such as leakage or disconnection of the tube can occur.

4. Removal of the tube

- (1) Push the release button flange evenly and sufficiently to release the tube. Do not push in the tubing before pressing the release button.
- (2) Hold down the release button while pulling out the tube. If the release button is not held down fully, it will be more difficult to pull out the tube.
- (3) If the removed tubing is to be used again, cut off the section of the tubing which has been gripped. Re-using the gripped portion of the tube can cause problems such as air leakage or difficulty in removing the tube.

5. Other manufacturers' tubes

If tubes of brands other than SMC are used, confirm that the materials and tolerance of the tubing outside diameter will satisfy the following specifications.

- (1) Nylon tube: Within ± 0.1 mm
- (2) Soft nylon tube: Within ± 0.1 mm
- (3) Soft polyurethane tube: Within $+0.15$ mm, within -0.2 mm

Do not use tubing which does not meet these outside diameter tolerances. It may not be possible to connect them, or they may cause other trouble, such as air leakage or the tube pulling out after connection.

6. Piping

- (1) Allow a sufficient margin of tube length when piping, in order to prevent twisting, tensile, moment loads, vibration or impact being applied to the tubes and fittings.
This can cause damage to the tube fittings and crushing, bursting or disconnection of tubing.
- (2) Piping to the product is assumed to be static piping.
If the tube moves, it may become worn, elongated or torn due to tensile forces, or disconnected from the fitting. Ensure the tube is in a static condition at all times before using.
- (3) Prevent the connected tube from being rotated.
If the fittings are used in this way, the fitting may be broken.
- (4) Do not lift the product by holding the piping after the tube is connected to the vacuum (V) port.
Otherwise, the filter case and/or the One-touch tube fitting will be damaged.

4. Solenoid Valve

Manual override operation

Regardless of an electric signal for the valve, the manual override is used for switching the main valve. Connected actuator is started by manual operation. A diagnosis information may occur when using the manual override during fieldbus communication. Use the manual override when the power supply is turned off. Manual override is non-locking push type. Push the manual override with a screwdriver of a diameter smaller than the hole until it reaches the end. Confirm that the product operates safely before the manual override is operated.

LED indication

Red LED turns on when the supply valve is energized. Green LED turns on when the release valve is energized.

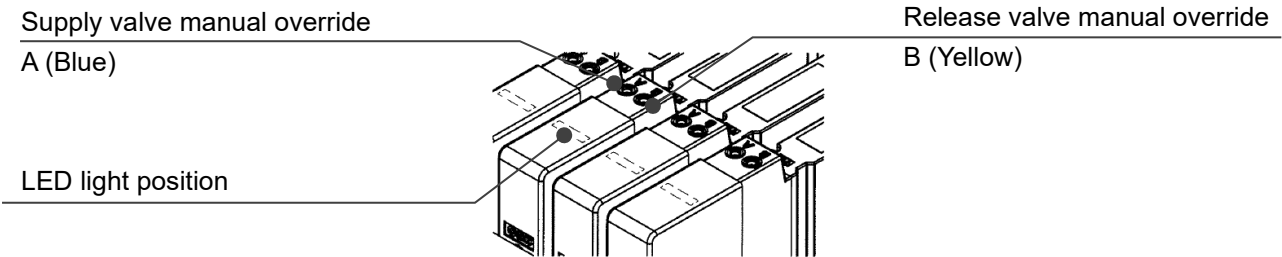

Electrical wiring

Wiring should be connected as shown below. Light/surge voltage suppressor circuit is equipped.

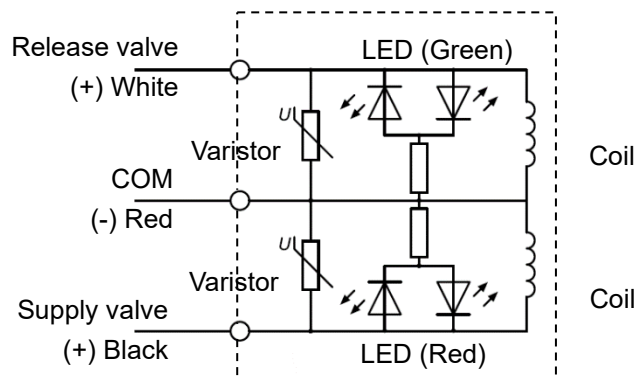

Precautions

1. Extended periods of continuous energization

If a valve will be continuously energized for an extended period of time, the temperature of the valve will increase due to the heat generated by the coil assembly. This will likely adversely affect the performance of the valve and any nearby peripheral equipment. Therefore, if the valve is to be energized for periods of longer than 30 minutes at a time, or if during the hours of operation the energized period per day is longer than the de-energized period, we advise using a N.O. (normally open) valve.

2. Resumption after a long period of holding time

When resuming operation after a long period of holding time, there are cases in which, regardless of whether the product is in an ON or OFF state, there is a delay in the initial response time due to adhesion. Conducting several cycles of running-in operation will solve this problem. Please consider implementing this before resumption.

3. Energization

When workpiece is being adsorbed, please keep generating the vacuum pressure to prevent the workpiece from dropping. Do not perform the operation to generate vacuum and release pressure at the same time. It may cause malfunction.

4. Air leakage

Zero air leakage is not guaranteed for the supply valve or release valve. Be aware that because there is a chance of air and vacuum leakage, the pressure may change if the V port side is tightly sealed.

5. SI Unit

The SI Unit controls a vacuum manifold. The SI Unit compatible with the vacuum manifold is shown below.

Part number	Protocol
EX260-VEC1	EtherCAT®
EX260-VPN1	PROFINET
EX260-VEN1	EtherNet/IP™
EX260-VIL1	IO-Link

The following vacuum unit parameters can be set by SI Unit.

Parameter	Explanation
Channel	Set whether the vacuum unit is installed at each station. ^{Note 1)}
Supply valve type	Set the supply valve type (Normally Open (N.O.) or Normally Close (N.C.)).
Energy saving function	Set Enable/Disable of energy saving function. ^{Note 2)}
Pressure value	Set the value for energy saving function and vacuum/release confirmation.
Pressure range	Set the rated pressure range of pressure sensor.
Count value	Set the value for valve protection function.

Note 1) When the positive pressure unit or blanking plate is installed, set Disable for each channel.

Note 2) When Option “Y” for the vacuum unit is selected, set Disable for energy saving function.

■ Energy saving function

While the vacuum instruction signal is ON, the supply valve closes automatically when the vacuum pressure reaches the setting value. The supply valve then opens automatically and generates vacuum when the vacuum pressure drops.

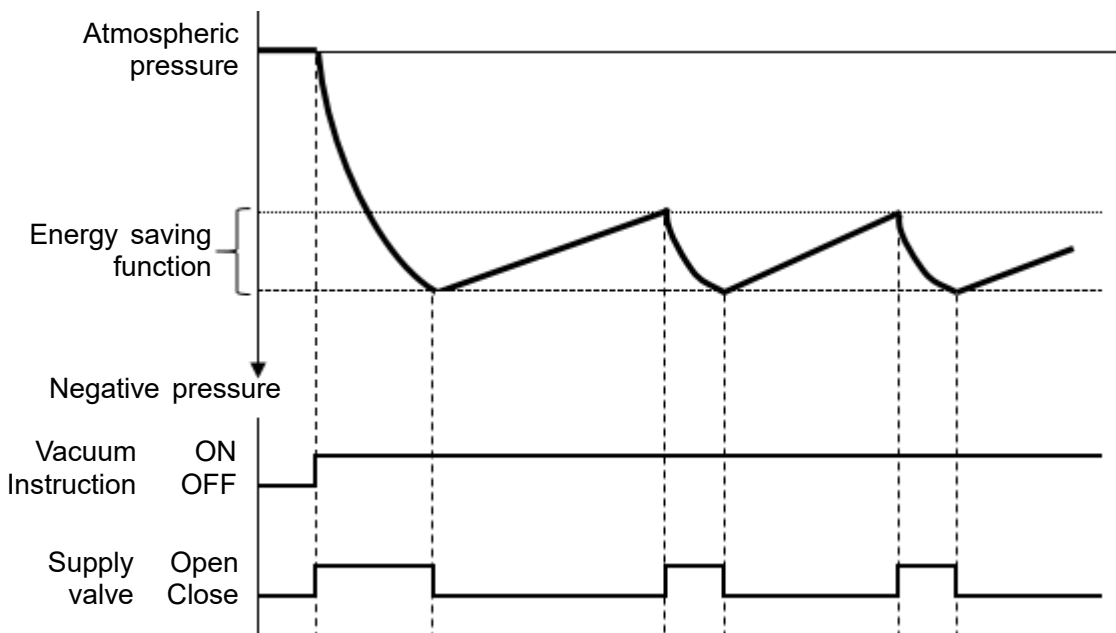

■ Pressure value

The pressure value parameter for energy saving function (P2, H2), vacuum confirmation (P1, H1) and release confirmation (P3, H3) can be set. The release pressure varies depending on the supply pressure, piping conditions and the number of vacuum units operating simultaneously. Set the release confirmation signal value with care.

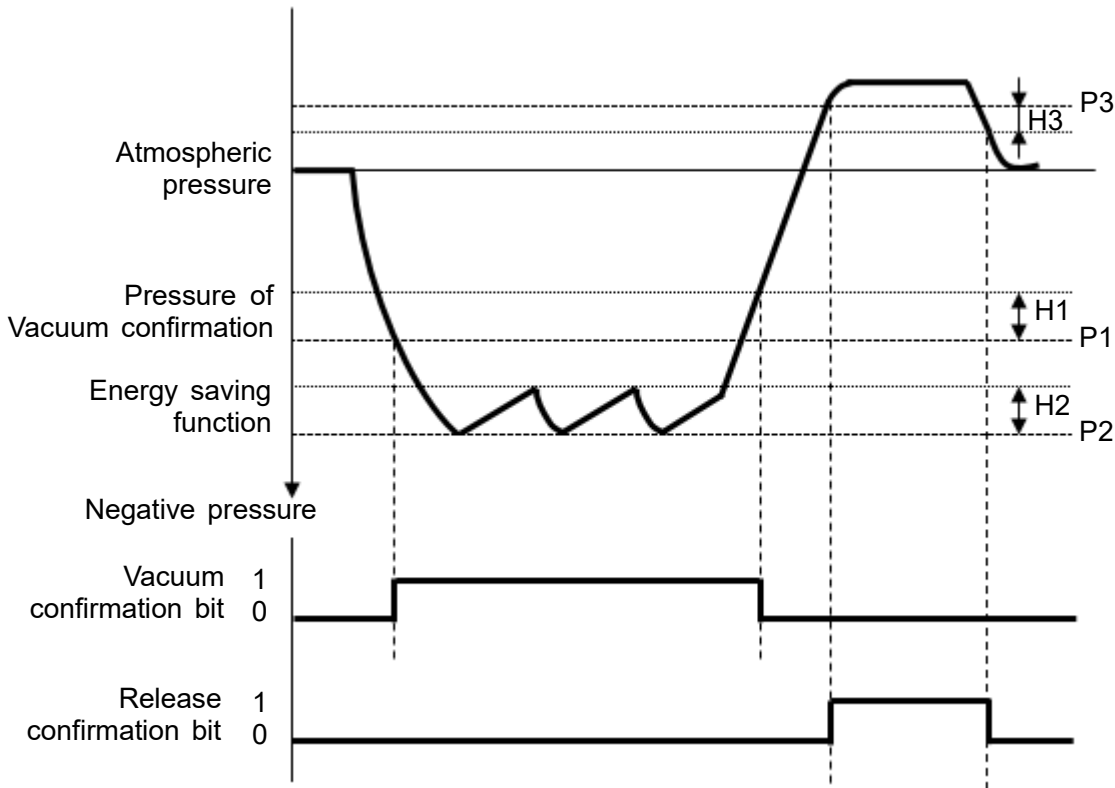

■ Valve protection

During operation of energy saving function, if the switching of vacuum stop/generate has reached the 'Count value', energy saving operation automatically switches to continuous adsorbing to prevent excessive valve operation.

Energy saving function resumes by turning the power supply for the logic/sensors or for the valves OFF/ON, or instruction for releasing valve protection from the SI Unit.

If valve protection operates with high frequency, review the setting value or perform maintenance to the vacuum units and pads.

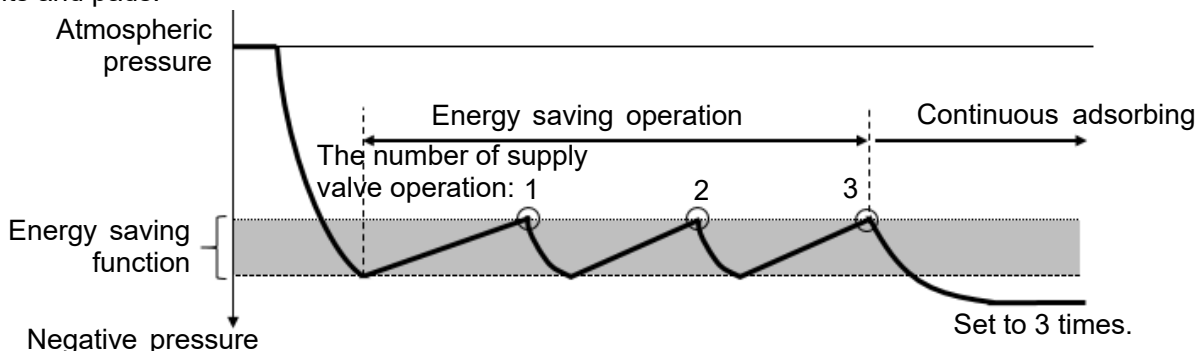

■ Zero clear

This function adjusts the displayed pressure to zero.

When using the SI Unit for the first time, perform zero clear when the residual pressure is exhausted and the pressure is not applied.

■ For further details of the parameters and functions, refer to the SI Unit Operation Manual.

6. Construction/Replacement Parts

6.1. Construction

■ Vacuum Unit

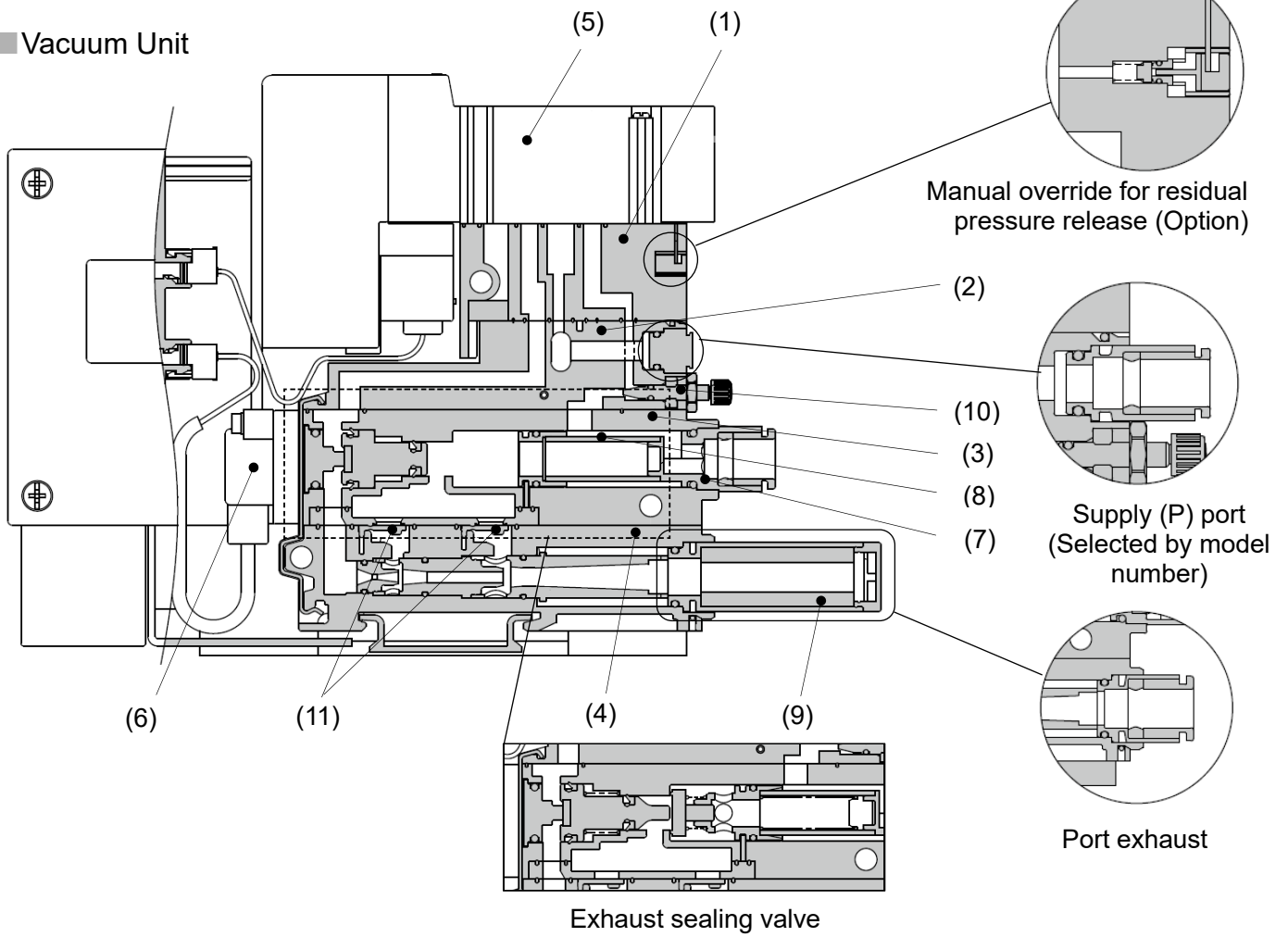

■ Positive pressure Unit

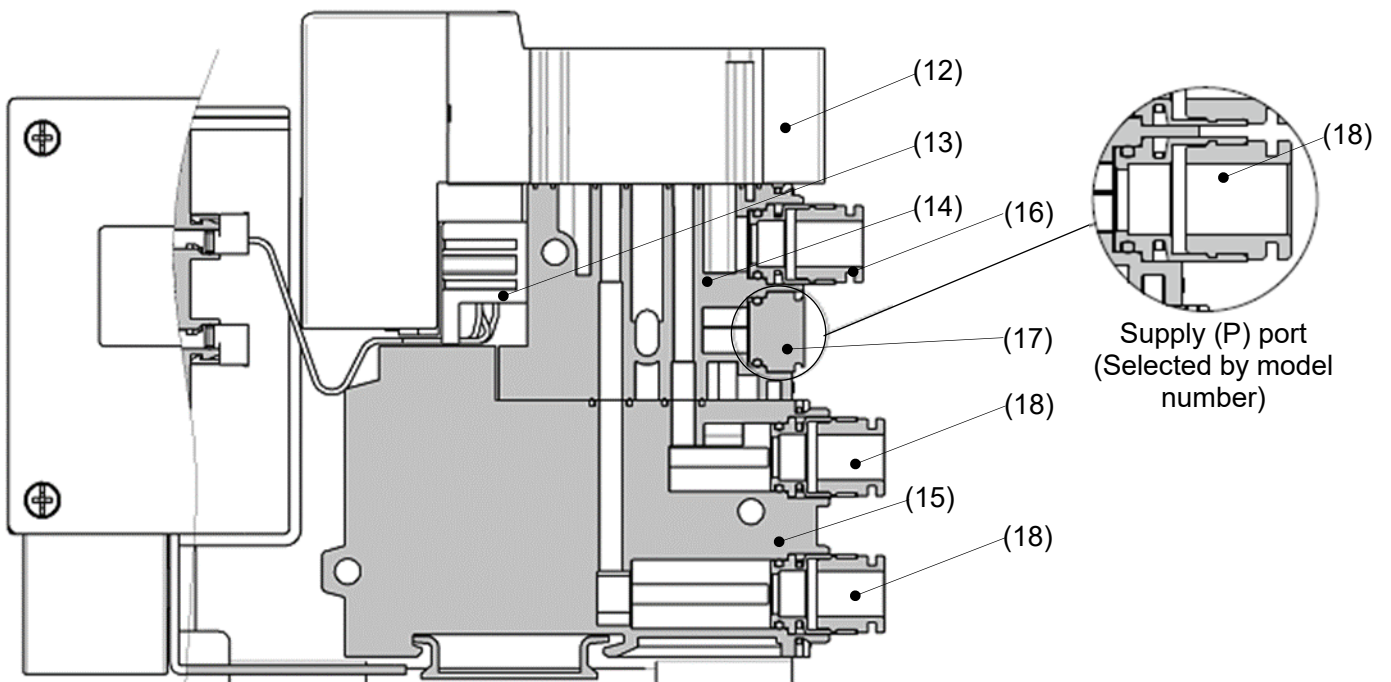

6.2. Component Parts

Vacuum Unit

No.	Item	Material	Remarks
1	Valve adapter assembly	PBT	FKM, HNBR, SUS and aluminum are also used
2	Valve body assembly	PBT	FKM and SUS are also used
3	Sealing valve body assembly	PBT	FKM, HNBR, SUS and aluminum are also used
4	Ejector body assembly	PBT	HNBR and SUS are also used
5	Supply valve and release valve assembly	-	Refer to Replacement Parts on Page 21
6	Pressure sensor assembly	-	-
7	Vacuum port adapter assembly	-	Refer to Replacement Parts on Page 21 One-touch fitting with filter element (with spring when exhaust sealing valve specification)
8	Filter element	Non-woven close	Refer to Replacement Parts on Page 21 Nominal filtration rating: 30µm, 10 pcs. per set
9	High-noise reduction silencer assembly One-touch fitting assembly	POM,PVA -	Refer to Replacement Parts on Page 21 With sound absorbing material Port size; mm: ø8, inch: ø5/16"
10	Needle assembly	Brass	Electroless nickel plated brass, resin, steel and FKM are also used
11	Check valve	HNBR	When option "Y" is selected, the check valve on the left side as shown in the construction figure is not mounted

Positive pressure Unit

No.	Item	Material	Remarks
12	Valve assembly	-	-
13	Valve connector assembly	-	-
14	Adapter plate assembly	PBT	HNBR and SUS are also used
15	Body assembly	PBT	HNBR and SUS are also used
16	One-touch fitting assembly	-	Refer to Replacement Parts on Page 21
17	Port plug assembly	-	Refer to Replacement Parts on Page 21
18	One-touch fitting assembly	-	Refer to Replacement Parts on Page 21

6.3. Replacement Parts

(5) Supply valve and release valve assembly

[With two mounting screws]

ZKJ - JSY3 A 00 - 5U

(Tightening torque for mounting screw: 0.2 Nm)

● Valve type

Symbol	Supply valve	Release valve
A	N.C.	N.C.
E	N.O.	N.C.

(7) Vacuum port adapter assembly

(Purchasing order is available in units of 1 piece.)

ZKJ - VA1S 8 FV - A

● One-touch fitting size

6	ø6	Metric
8	ø8	
7	ø1/4"	Inch
9	ø5/16"	

● Exhaust sealing valve specification

Nil	For vacuum unit without exhaust sealing valve
V	For vacuum unit with exhaust sealing valve (with spring)

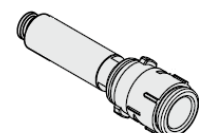
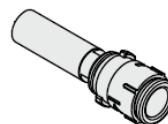

For vacuum unit with exhaust sealing valve

(8) Filter element
(10 pcs. per set)

ZK2 - FE1 - 3 - A

● Nominal filtration rating

3	30µm
---	------

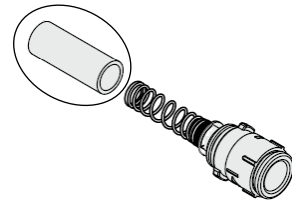
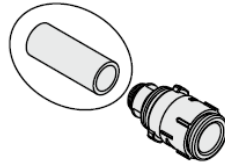

For vacuum unit with exhaust sealing valve

(9) High-noise reduction silencer assembly

ZK2 - SC3F - 4 - A

● Nozzle size

4	For nozzle size 07, 10
6	For nozzle size 12, 15

One-touch fitting assembly
(Purchasing order is available in units of 10 pieces.)

VVQ1000 - 51A - C8

● Port size

C8	ø8 One-touch fitting
N9	ø5/16" One-touch fitting

Sound absorbing material for High-noise reduction silencer (5 pcs. per set)

ZK2 - SE4 - 6 - A

(16) One-touch fitting assembly (Purchasing order is available in units of 10 pieces.)

VVQ1000 - 51A - C8

● Port size

C8	ø8 One-touch fitting
N9	ø5/16" One-touch fitting

(17) Port plug assembly

VVQZ2000 - CP

(18) One-touch fitting assembly (Purchasing order is available in units of 10 pieces.)

VVQ1000 - 51A - C6

● Port size

C6	ø6 One-touch fitting
C8	ø8 One-touch fitting
N7	ø1/4" One-touch fitting
N9	ø5/16" One-touch fitting

7. Exploded View of Manifold/Replacement Parts

7.1. Exploded View of Manifold

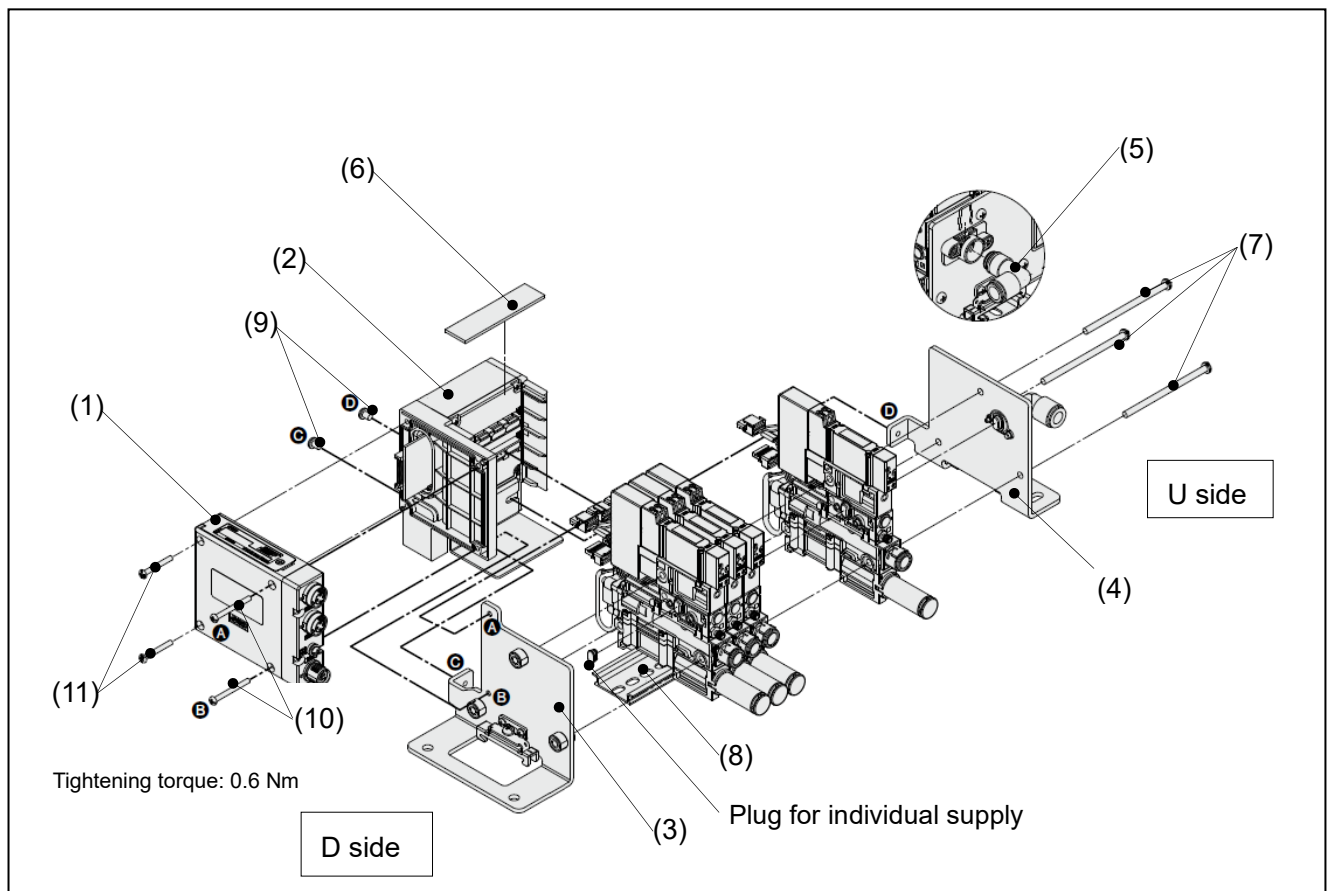

7.2. Component Parts for Manifold

No.	Item	Material	Remarks
1	SI Unit	-	Refer to Replacement Parts on Page 24
2	Control Unit	-	Refer to Replacement Parts on Page 24
3	D side end plate assembly	SUS	Refer to Replacement Parts on Page 24
4	U side end plate assembly	SUS	Refer to Replacement Parts on Page 24
5	One-touch fitting elbow assembly	-	Refer to Replacement Parts on Page 24
6	Protection plate	PC	Refer to Replacement Parts on Page 24
7	Tension bolt	steel	Refer to Replacement Parts on Page 24
8	DIN rail	aluminum	Refer to Replacement Parts on Page 24
9	Round head combination screw	steel	Refer to Replacement Parts on Page 24
10	Round head combination screw	steel	Refer to Replacement Parts on Page 24
11	Round head combination screw	steel	Refer to Replacement Parts on Page 24

7.3. Replacement Parts

(1) SI Unit

EX260 - V PN 1

● SI Unit

Symbol	Protocol
EC	EtherCAT®
EN	EtherNet/IP™
PN	PROFINET
IL	IO-Link

(2) Control Unit

ZKJ - S0 04 - A

● Applicable stations

04	For 4 stations manifold
08	For 8 stations manifold
12	For 12 stations manifold
16	For 16 stations manifold

(3) D side end plate assembly

ZKJ - ED1 - A

(4) U side end plate assembly

ZKJ - EU1 - L8 - A

● Symbol

L8	ø8 One-touch fitting elbow
LN9	ø5/16" One-touch fitting elbow

(5) One-touch fitting elbow assembly

SZ3000 - 74 - 1A - L8 (ø8 Elbow)

KQ2L09 - 14 - X224 (ø5/16" Elbow)

(6) Protection plate

ZKJ - PL2 - 4 - A

● Applicable stations

4	For 4 stations manifold
8	For 8 stations manifold
12	For 12 stations manifold
16	For 16 stations manifold

(7) Tension bolt (3 pcs. per set)

ZKJ - TB1 - 4 - A

● Applicable stations

4	For 4 stations manifold
8	For 8 stations manifold
12	For 12 stations manifold
16	For 16 stations manifold

(8) DIN rail

VZ1000 - 11 - 1 - 1

● Length symbol

1	For 4 stations manifold (110.5mm)
6	For 8 stations manifold (173mm)
10	For 12 stations manifold (223mm)
15	For 16 stations manifold (285.5mm)

(9) Round head combination screw (10 pcs. per set)

ZKJ - TB2 - A (M4 x 5)

(10) Round head combination screw (10 pcs. per set)

ZKJ - TB3 - A (M3 x 30)

(11) Round head combination screw (10 pcs. per set)

ZKJ - TB4 - A (M3 x 24)

7.4. Manifold Option

■ Blanking plate (With two connector plug assembly)

ZKJ - BP1 - A

Used in situations where vacuum units and positive pressure units are not mounted for manifold.

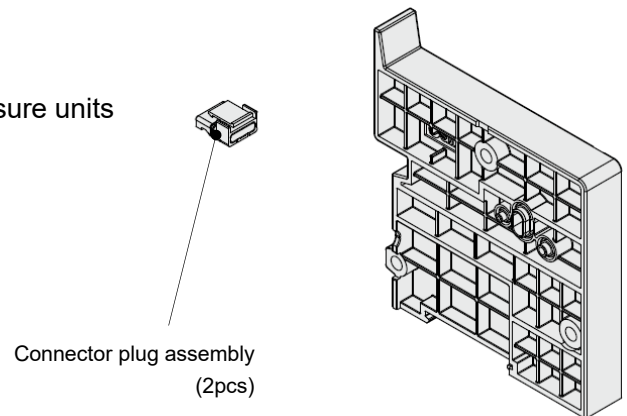

When a blanking plate is used in the SI unit's default settings, the diagnostic information (pressure sensor disconnection) is issued. Change the SI unit settings in accordance with the selected type.

■ Plug for individual supply

ZK2 - MP2F - A

By placing "Plug for individual supply" in a vacuum manifold's pressure supply passage, two different pressures can be supplied to one manifold.

The supply (P) port for vacuum manifold is mounted only on the U side.

Be sure to select the supply (P) port for model number on the D side

of the vacuum unit and positive pressure unit where the plug for individual supply is mounted.

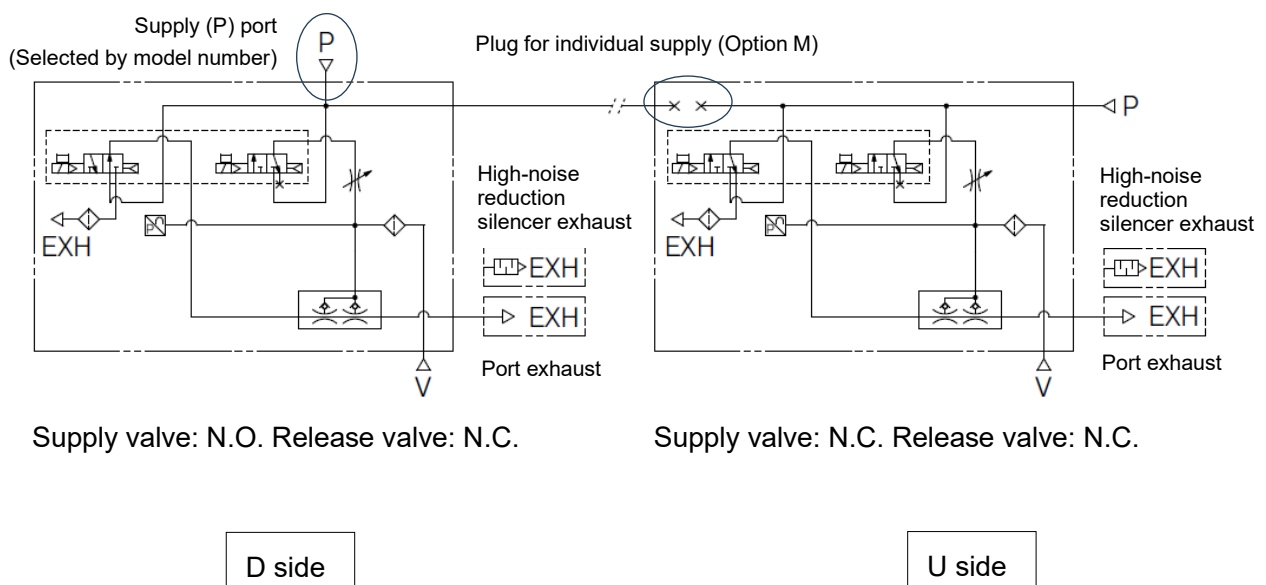

7.5. How to Increase Manifold Stations

- 1) Remove two screws from the back of the Control Unit and two screws from the side of SI Unit.

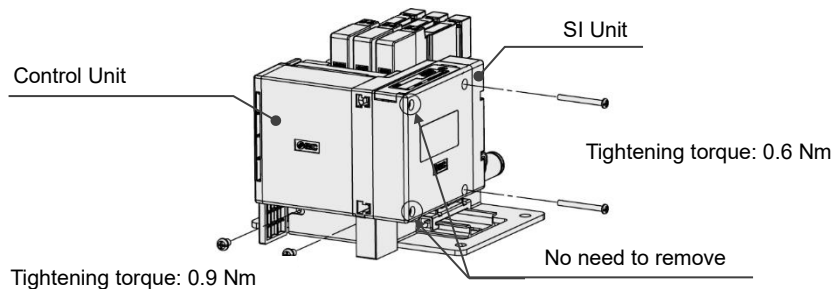

- 2) Separate the connected vacuum units from the Control Unit.
- 3) Loosen the screw of the DIN rail mounting bracket on the End plate U as shown below (no need to remove the screw).

- 4) Remove three tension bolts.
- 5) Remove the End plate U from the DIN rail.
- 6) Remove the Protection plate.

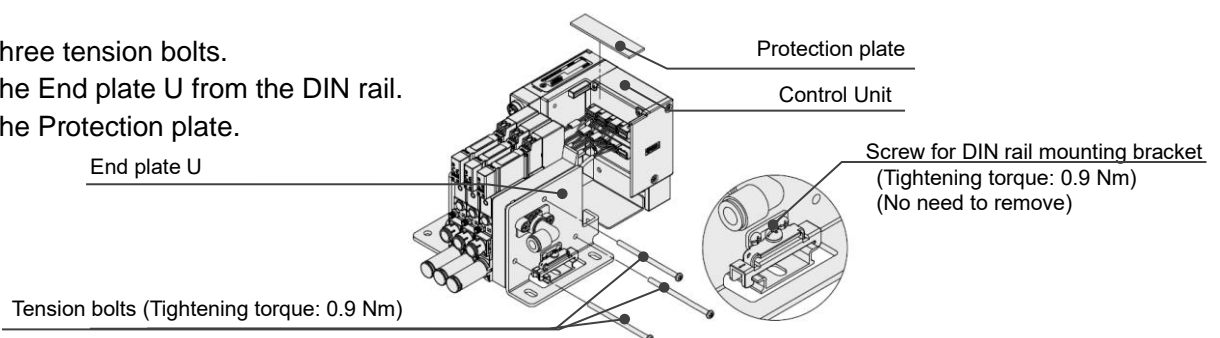

- 7) Separate the blanking plate from the connected vacuum units and remove the hook from the groove by pressing the blanking plate as shown Fig. A. Remove the blanking plate from the DIN rail.
- 8) Remove the connector plug assembly connected to the Control unit. To detach the connector, hold the lever and connector body. Remove the hook from the groove by pressing the lever downward, and pull the connector straight out.
- 9) Mount the vacuum units to be added on the DIN rail, and align and connect the air passages of vacuum units so that the lead wires do not get caught.
- 10) Insert the supply valve and release valve assembly connector to the top of the Control Unit (VALVE), and the pressure sensor assembly connector to the bottom of the Control Unit (SENSOR). Lock the connectors by pushing the lever hook into the concave groove on the housing.

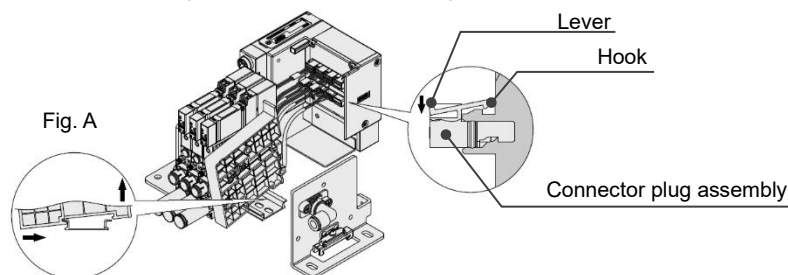

- 11) Mount each of the removed parts by following steps (1) to (6) in reverse.

Note1) When exchanging the first station

When exchanging to the vacuum unit or positive pressure unit, order each unit with the plug for individual supply (option M). When exchanging to the blanking plate, order the blanking plate and the plug for individual supply separately and mount it on the D side of blanking plate. Refer to [Manifold option](#) on page 25.

Note2) When increasing over 4, 8, 12 manifold stations, exchange the Control Unit, Tension bolts, Protection plate and DIN rail for suitable parts for manifold stations. Refer to [Replacement Parts](#) on page 24.

8. Maintenance

8.1. Maintenance

Implement the maintenance and checks shown below in order to use the vacuum manifold safely and in an appropriate way for a long period of time.

- 1) Maintenance should be performed according to the procedure indicated in the Operation Manual. Improper handling can cause damage and malfunction of equipment and machinery.
- 2) Maintenance work
Compressed air can be dangerous when handled incorrectly. Therefore, in addition to observing the product specifications, replacement of elements and other maintenance activities should be performed by personnel with sufficient knowledge and experience pertaining to pneumatic equipment.
- 3) Draining
Remove condensate from air filters and mist separators regularly. If the collected drainage is drained to the downstream side, it can stick inside of the product, causing operation failure and failure to reach the specified vacuum pressure.
- 4) Replace the filter element built into the vacuum unit and the silencer regularly (refer to the replacement procedure below.).
It is recommended to replace the filter element and the silencer when the pressure drop reaches 5kPa as a guideline. The replacement cycle varies depending on the operating conditions, operating environment and supply air quality.
However, if there is a vacuum pressure drop and/or delay in the vacuum (adsorption) response time which causes problem with the settings during operation, stop the operation of the product and replace the element regardless of the above mentioned replacement guideline.
- 5) Operation in an environment where there is a lot of dust in the air
The processing capacity of the filter element built into the product may be insufficient. It is recommended to use SMC's air suction filter (ZFA, ZFB, ZFC series) in order to avoid problems beforehand.
- 6) Check before and after the maintenance work
When the product is to be removed, turn off the power supply, and be sure to cut off the supply pressure and exhaust the compressed air. Confirm that the air is released to atmosphere.
When mounting the product after the maintenance work, supply compressed air, connect to the power, check if it functions properly and have a leakage inspection.
- 7) Do not disassemble or modify the product, other than the replacement parts specified in this manual.
- 8) Tighten to the specified tightening torque.
If the tightening torque is exceeded, the product, the mounting screws, brackets can be broken. Insufficient torque can cause displacement of the product from each proper position and loosening of the mounting screws.
- 9) Eliminate any dust left in the piping by using a blast of air before connecting the piping to the product.
Otherwise, failure or malfunction may occur.
- 10) If the fluid contains foreign matter, install and connect a filter or mist separator to the inlet.
Otherwise, failure, malfunction or inaccurate measurements from the pressure sensor may occur.

8.2. Replacement Procedure

8.2.1. Replacement procedure for filter element

Be sure to install the filter element. If the filter element is not installed, this can result reduced performance.

- 1) To pull out the vacuum port adapter assembly, rotate the adapter by about 90 degrees in direction A and pull in direction B. The adapter can be removed with the filter element from the sealing valve body.
- 2) Remove the filter element from the vacuum port adapter assembly and replace it with a new filter element. When the vacuum unit is exhaust sealing valve type, be careful not to drop the spring from the vacuum port adapter.

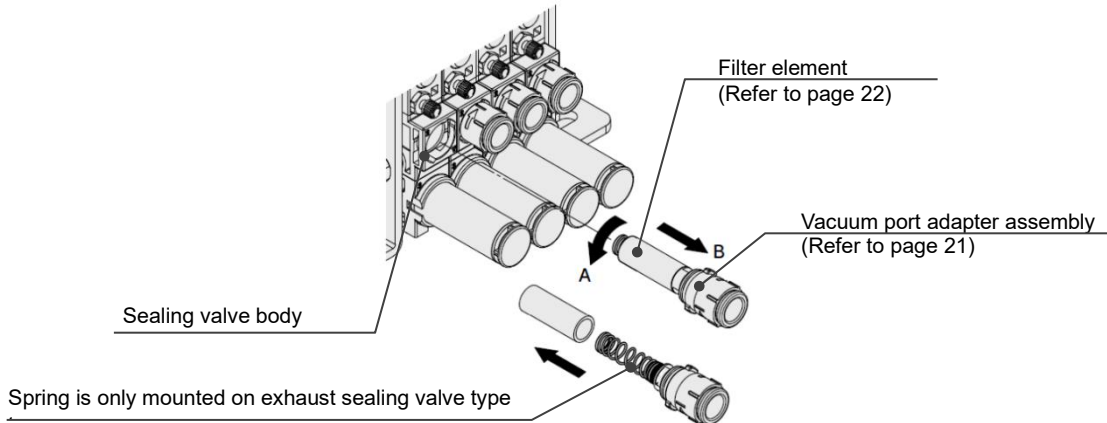

- 3) When installing the filter, insert the filter to the end so that there is no gap or bending between the filter element and the vacuum port adapter. A gap or bending will cause interference with internal parts, the filter element to deform and deterioration of the performance.



- 4) Put the filter element back into the sealing valve body following this procedure in reverse. To mount the vacuum port adapter assembly into the sealing valve body assembly, turn the vacuum port adapter so that the mark of the adapter is on top (rotation stops there.).

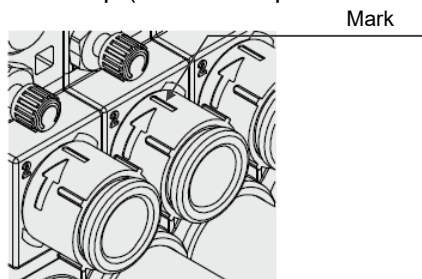

If it is difficult to remove the vacuum port adapter assembly, you can remove the adapter with a hexagon wrench using the hexagonal hole in V port. The table shows the port size and the width across flats.

V port size	Width across flats
ø6	4
ø8, ø5/16"	6
ø1/4"	4.76

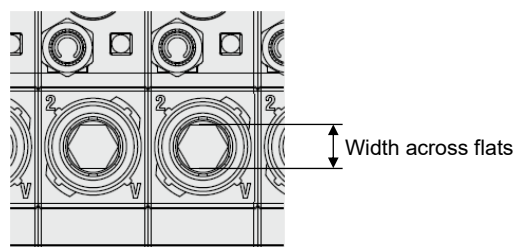

8.2.2. Replacement procedure for vacuum unit exhaust port (High-noise reduction silencer assembly, One-touch fitting assembly)

- 1) Flip the vacuum manifold.
- 2) To remove the clip that holds the High-noise reduction silencer, insert a precision screwdriver. Move the screwdriver to pull out the clip.

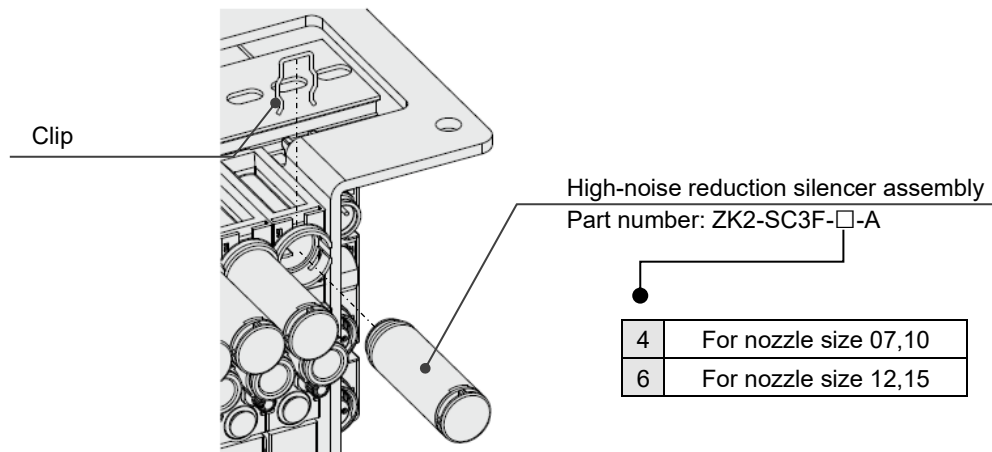

- 3) Remove the High-noise reduction silencer.

(Procedure to put parts back together)

- 4) Insert the High-noise reduction silencer and insert the clip into the groove. (Push completely to the end.)

Note1) The figure shows in the case of High-noise reduction silencer assembly.

Note2) Do not pull or bend the two projections at the end surface of the diffuser. These are spacers to prevent the displacement of the diffuser and they may break if force is applied.

When only replacing the Sound Absorbing Material (for High-noise Reduction Silencer exhaust)

- 1) Use the notch to remove the cap.
- 2) Use a precision screwdriver to remove the sound absorbing material.
- 3) Insert the new sound absorbing material, and return the cap.

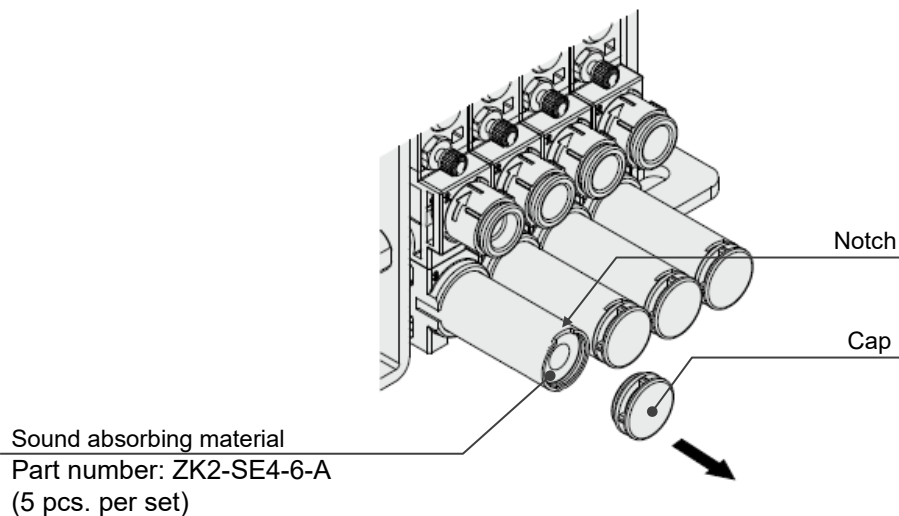

8.2.3. Replacement procedure for positive pressure unit each port (one-touch fitting assembly)

8.2.3.1. exhaust port, P port and B port

- 1) Remove the two screws from the valve assembly.
- 2) Remove the solenoid valve assembly from the adapter plate assembly and the valve connector assembly.

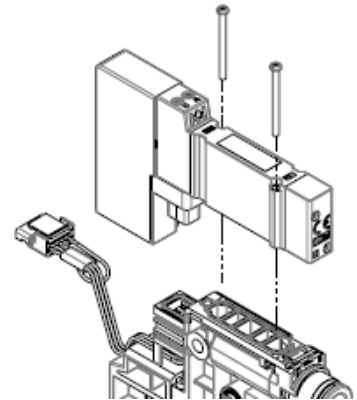

- 3) To remove the clip that holds the one-touch fitting assembly for the exhaust port and the P port, insert a precision screwdriver. Move the screwdriver to pull out the clip.
- 4) Remove the one-touch fitting assembly/port plug assembly for the exhaust port and the P port.

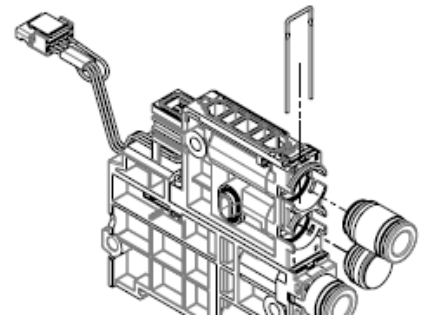

- 5) To remove the clip that holds the one-touch fitting assembly for the B port, insert a precision screwdriver. Move the screwdriver to pull out the clip.
- 6) Remove the one-touch fitting assembly for the B port.

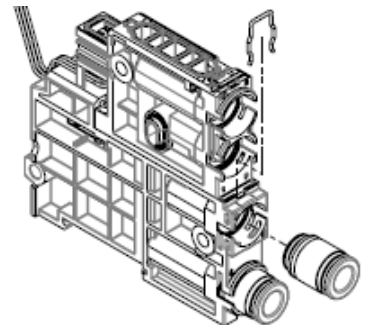

(Procedure to put parts back together)

- 7) Insert the one-touch fitting assembly into the B port and insert the clip into the groove (Push completely to the end).
- 8) Then insert the one-touch fitting assembly/port plug assembly into the exhaust port and the P port and insert the clip into the groove (Push completely to the end).

8.2.3.2. A port

- 1) The A port is the same replacement procedure for the vacuum unit exhaust port.

9. Specifications

■ Vacuum unit ^{Note 1)}

Model		ZKJ07	ZKJ10	ZKJ12	ZKJ15	
Fluid		Air				
Nozzle diameter [mm]		0.7	1.0	1.2	1.5	
Standard supply pressure [MPa]		0.4				
Max. vacuum pressure [kPa] ^{Note 2)}		-89				
Max. Suction flow ^{Note 2) 3)} [L/min(ANR)]	Port exhaust	Without exhaust sealing valve	31	53	63	74
		With exhaust sealing valve	30	48	57	-
	High-noise reduction silencer exhaust	Without exhaust sealing valve	31	51	60	68
		With exhaust sealing valve	30	45	54	-
Air consumption [L/min(ANR)] ^{Note 2)}		26	48	68	102	
Supply pressure range [MPa]		0.3 to 0.5				
Type of actuation		Supply valve: N.C., Release valve: N.C. (ZKJ-JSY3A) Supply valve: N.O., Release valve: N.C. (ZKJ-JSY3E)				
Response time at 0.5 [MPa] ^{Note 4)}		23ms or less				
Max. operating frequency		3Hz				
Manual override		Non-locking push type				
Power consumption		0.4W				
Environmental resistance	Ambient temperature range		0~50°C (No condensation)			
	Vibration resistance ^{Note 5)}		30m/s ²			
	Impact resistance ^{Note 6)}		150m/s ²			
	Withstand voltage		500 [VAC] for 1 [min] between FE and all accessible terminals			
	Insulation resistance		10 [MΩ] or more (500 [VDC] is given between FE and all accessible terminals)			
	Enclosure ^{Note 7)}		IP65			
Standards		CE/UKCA marked (EMC, RoHS)				

Note 1) The supply valve and release valve mounted on this product is the SMC dual 3-port valve JSY3000 series. Refer to the Web Catalogue for details on the JSY3000 series.

Note 2) Values at the standard supply pressure. Values are based on standard of SMC measurements. They depend on atmospheric pressure (weather, altitude, etc.) and the measurement method.

Note 3) If the vacuum port diameter is $\Phi 6$ or $\Phi 1/4$ ", Max. Suction flow rate is reduced by 15% or less.

Note 4) It shows supply valve/release valve specification. Based on dynamic performance test, JIS B 8419-2010 (Coil temperature: 20[°C], at rated voltage).

Note 5) The characteristics are satisfied when tested for 2 hours in each of the X, Y and Z directions at 10 to 500 Hz without energization (Initial value).

Note 6) The characteristics are satisfied when tested one time in each of the X, Y and Z directions without energization (Initial value).

Note 7) Cannot be used in an environment where oil, such as cutting oil, splashes or it is constantly exposed to water. Take appropriate protective measures.

Positive pressure unit

Model		ZKJ1V□P-15U	ZKJ1V□P-25U	ZKJ1V□P-A5U
Fluid		Air		
Supply pressure range [MPa]		0.3 to 0.5		
Type of actuation		2-position single	2-position double	4-position dual 3-port (N.C./N.C.)
Response time at 0.5 [MPa] ^{Note 4)}		18ms or less	12ms or less	23ms or less
Max. operating frequency		5Hz		
Manual override		Non-locking push type		
Power consumption		0.4W		
Environmental resistance	Ambient temperature range	0~50°C (No condensation)		
	Vibration resistance ^{Note 5)}	30m/s ²		
	Impact resistance ^{Note 6)}	150m/s ²		
	Withstand voltage	500 [VAC] for 1 [min] between FE and all accessible terminals		
	Insulation resistance	10 [MΩ] or more (500 [VDC] is given between FE and all accessible terminals)		
	Enclosure ^{Note 7)}	IP65		
Standards		CE/UKCA marked (EMC, RoHS)		

Positive pressure unit Flow Rate Characteristics

Model	Port size		1→4/2 (P→A/B)		4/2→3/5 (A/B→E)	
	1, 3/5 (P, E)	4, 2 (A, B)	C [dm ³ /(s·bar)]	b	C [dm ³ /(s·bar)]	b
ZKJ1VC6P-15U	C8	C6	1.33	0.38	1.44	0.39
ZKJ1VC6P-25U						
ZKJ1VC6P-A5U						
ZKJ1VC8P-15U		C8	1.46	0.46	1.44	0.28
ZKJ1VC8P-25U						
ZKJ1VC8P-A5U						

* Calculation of effective area S and sonic conductance C: $S = 5.0 \times C$

* Values measured in accordance with ISO 6358:1989, JIS B 8390:2000

Maximum Number of Manifold Stations that Can Operate Simultaneously ^{Note 8)}

Model	ZKJ07	ZKJ10	ZKJ12	ZKJ15
Air supply port: 1 Port (End plate U P port(ø8))	16	6	5	3
Air supply port: 2 Ports (End plate U P port(ø8), Vacuum unit P port(ø6))	16	8	7	4

Note 8) Values are the number of vacuum unit stations that can be generated vacuum simultaneously.

■ Noise Level (Reference values) Note 9) 10)

Model	ZKJ07	ZKJ10	ZKJ12	ZKJ15
Noise level[dB(A)]	52	63	67	71

Note 9) Values are at the standard supply pressure.

Note 10) Values are with 1 vacuum unit generating vacuum pressure adequately for adsorption with high-noise reduction silencer (Not guaranteed values).

■ Weight Note 11)

Manifold stations (vacuum units)	4 stations	8 stations	12 stations	16 stations
Weight[kg]	1.7	2.5	3.3	4.1

Note 9) When the blanking plate is mounted, please subtract 0.1 [kg] per unit.

■ SI Unit Specifications (For details, refer to the Operation Manual.)

Item			Specifications
Electrical	PWR	Operating voltage	24VDC±10%
		Internal current consumption at 24 VDC	100mA or less
	PWR(V)	Operating voltage	24VDC +10%,-5%
Vacuum	Functions		Energy saving Valve protection Zero clear

■ Control Unit Specifications

Model		ZKJ-S004-A	ZKJ-S008-A	ZKJ-S012-A	ZKJ-S016-A
Station		4	8	12	16
Input	Pressure sensor	4	8	12	16
	Pressure sensor short circuit detection / protection	Built-in (Common detection / protection)			
Output	Valve	8	16	24	32
	Valve short circuit detection / protection	Built-in (Individual detection / protection)			

■ Pressure Sensor specifications

(For details, refer to the PSE54□ series in the Web Catalog, and the Operation Manual.)

Item		Specifications
Rated pressure range	Without exhaust sealing valve	-100 to 100[kPa]
	With exhaust sealing valve	-100 to 200[kPa]
Withstand pressure <small>Note 12)</small>		500[kPa]
Accuracy		±3%F.S.
Current consumption		15mA or less
Pressure sensing section		Silicon

Note 12) Do not use the product to drive an actuator such as a cylinder (when release pressure is constantly applied).

10. Pneumatic Circuit

■ Vacuum unit

-No Option

Single unit: **ZKJ□□□-E5U-T1**

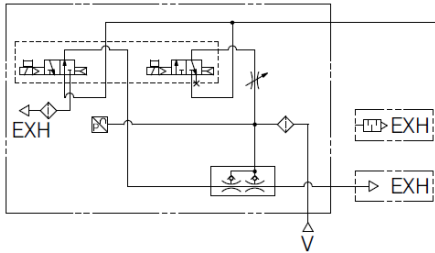

Supply valve: N.O. Release valve: N.C.

Single unit: **ZKJ□□□-A5U-T1**

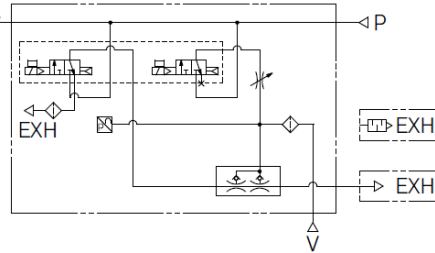

Supply valve: N.C. Release valve: N.C.

High-noise reduction
silencer exhaust

Port exhaust

-With manual override
for residual pressure release

Single unit: **ZKJ□□□-E5U-T1-R**

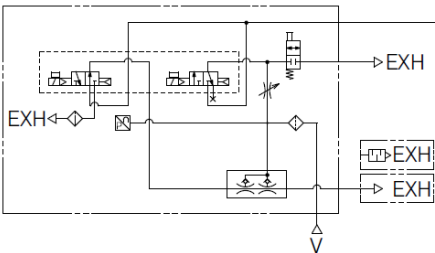

Supply valve: N.O. Release valve: N.C.

-With exhaust sealing valve

Single unit: **ZKJ□□□V-A5U-T2**

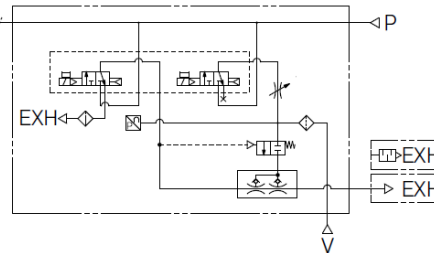

Supply valve: N.C. Release valve: N.C.

High-noise reduction
silencer exhaust

Port exhaust

-With supply port (P port)

Single unit: **ZKJ□□□U-E5U-T1**

Supply (P) port
(Selected by model number)

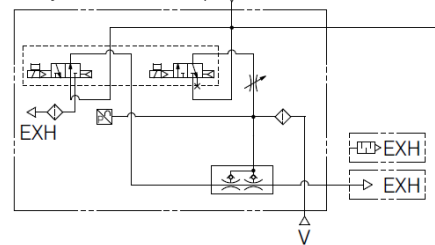

Supply valve: N.O. Release valve: N.C.

-With plug for individual supply

Single unit: **ZKJ□□□-A5U-T1-M**

Plug for individual supply (Option M)

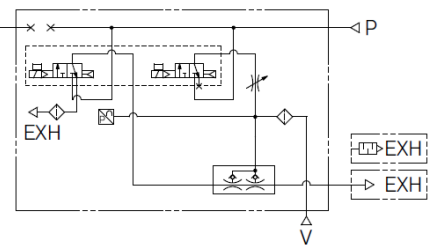

Supply valve: N.C. Release valve: N.C.

High-noise reduction
silencer exhaust

Port exhaust

■ Positive pressure unit

-No Option

Single unit:

ZKJ1V□P-15U

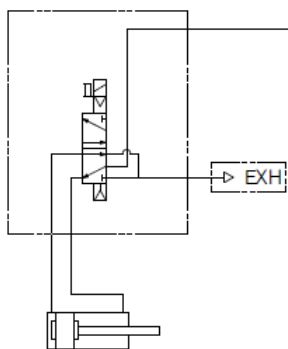

2-position single

ZKJ1V□P-25U

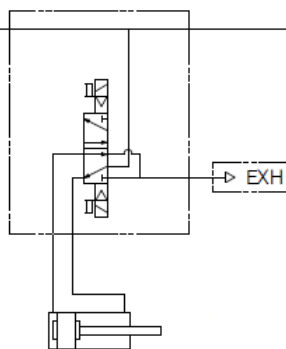

2-position double

ZKJ1V□P-A5U

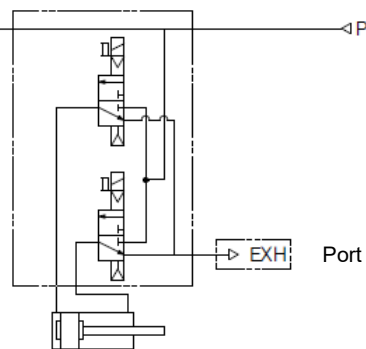

4-position dual 3-port (N.C./N.C.)

Port exhaust

11. Exhaust/Flow Rate Characteristics

11.1. Exhaust Characteristics/Flow Rate Characteristics (Representative value)

These values are at the standard supply pressure and based on standard of SMC measurements. They depend on atmospheric pressure (weather, altitude, etc.) and measurement method.

ZKJ07

Exhaust Characteristics

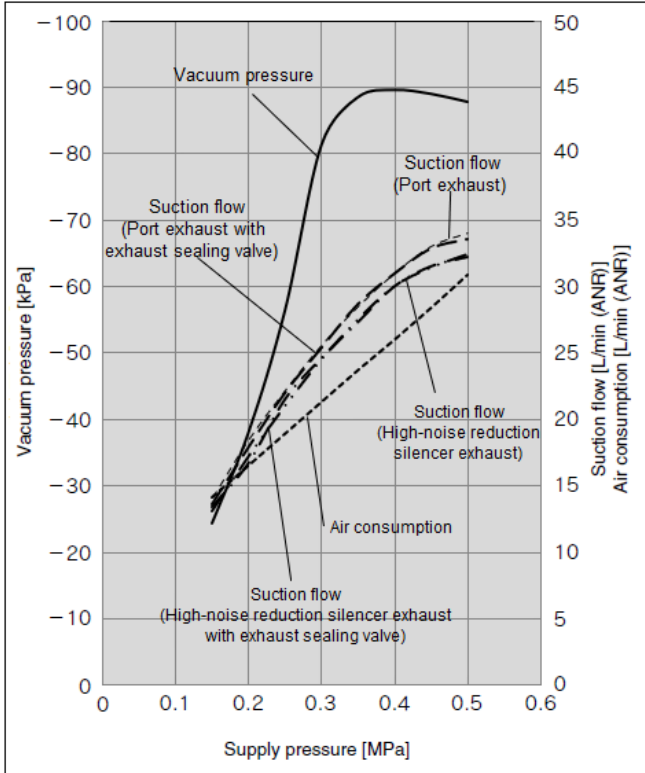

Flow Rate Characteristics

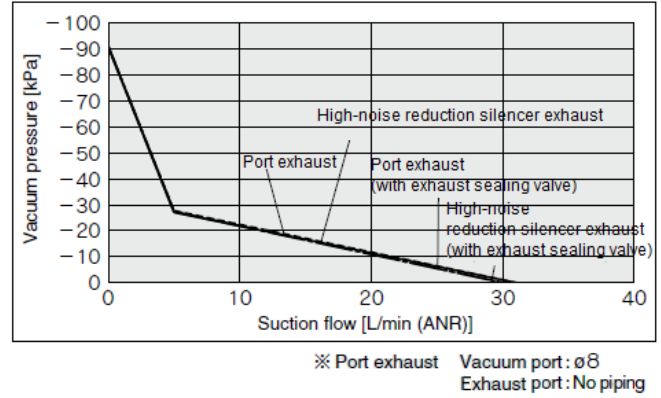

ZKJ10

Exhaust Characteristics

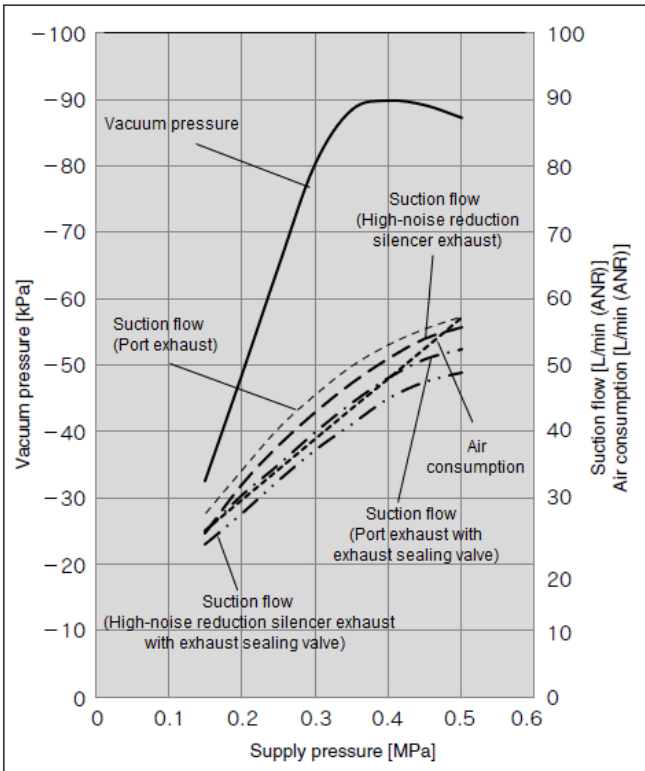

Flow Rate Characteristics

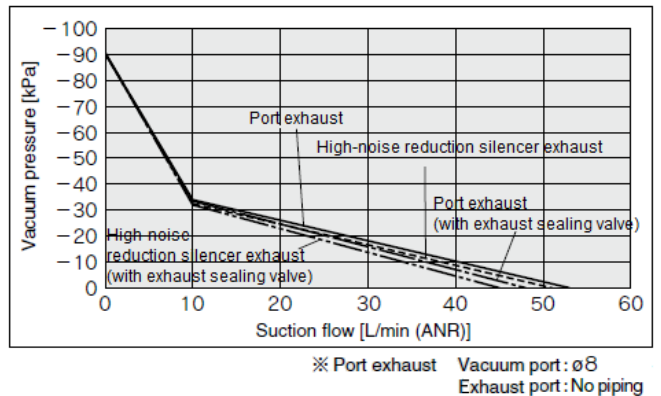

ZKJ12

Exhaust Characteristics

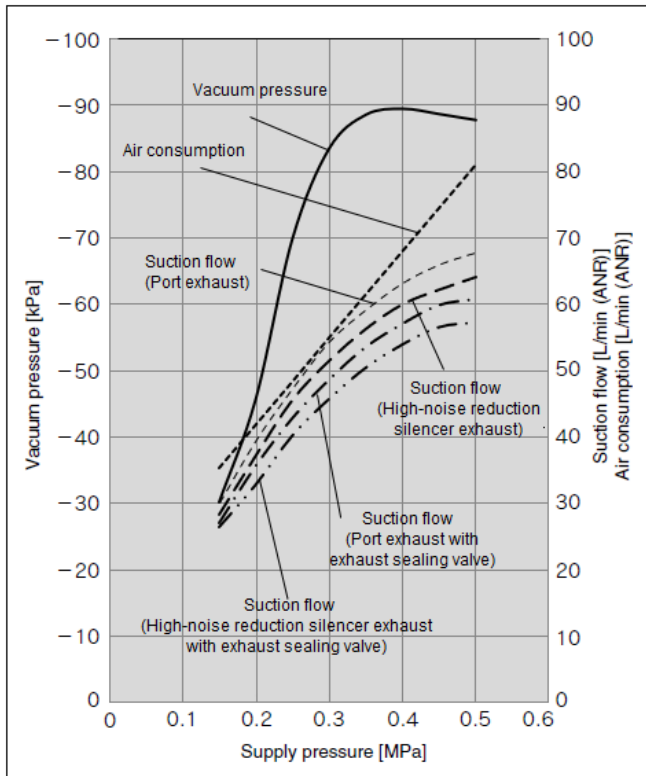

Flow Rate Characteristics

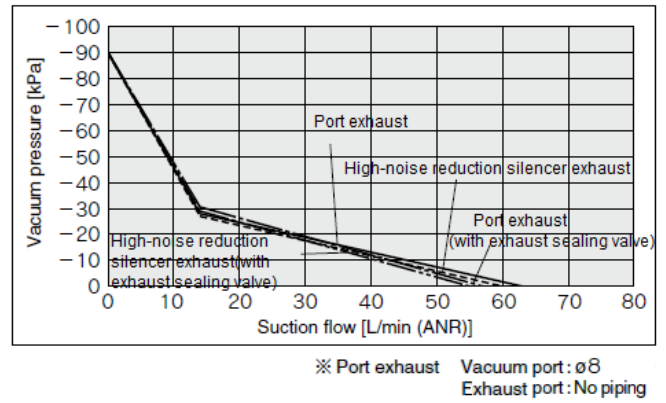

ZKJ15

Exhaust Characteristics

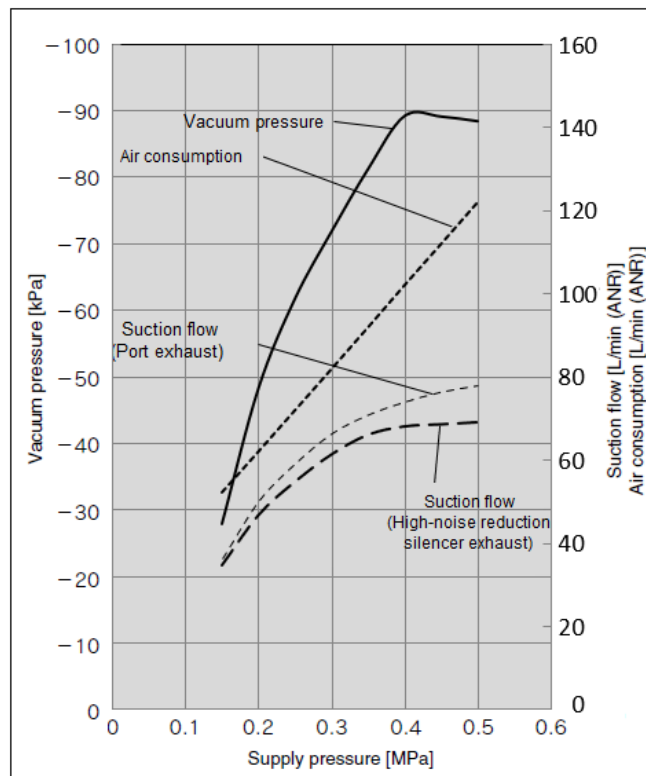

Flow Rate Characteristics

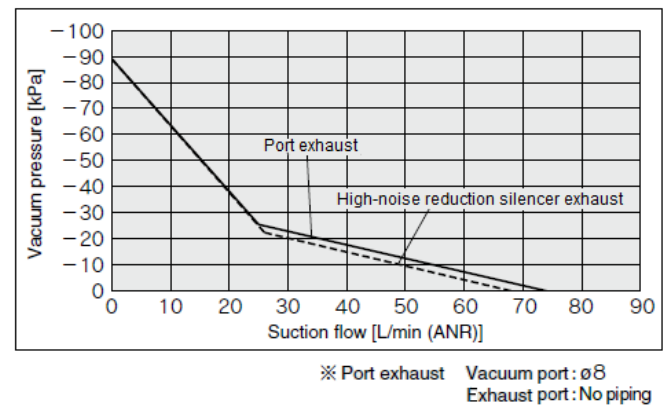

11.2. Release Flow Rate Characteristics (Representative value)

The graph shows the flow rate characteristics at different supply pressures when the release flow control valve is open from the fully closed state. The actual suction flow at the point of suction varies depending on the piping conditions to the vacuum port.

ZKJ07

without exhaust sealing valve

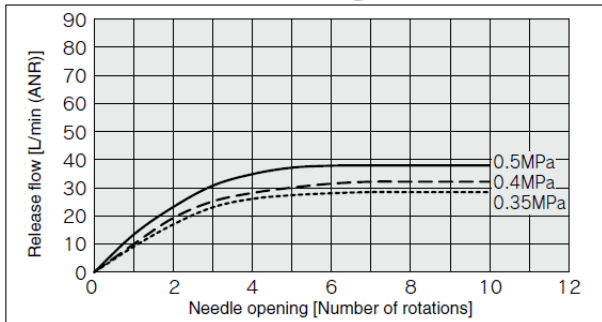

with exhaust sealing valve

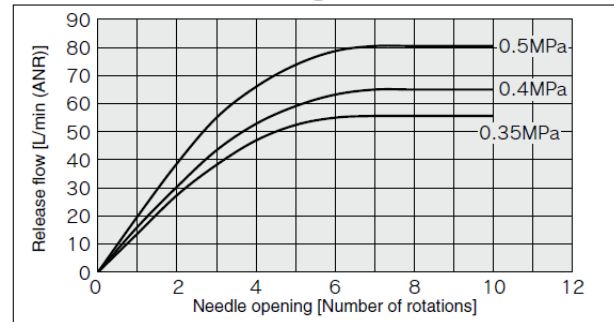

Precautions

- The flow rate characteristics show the representative values of the product itself.
They may change depending on piping, circuit and pressure conditions, etc. The flow rate characteristics and the number of needle rotations vary due to the range of the specifications of the product.
- The needle has a retaining mechanism, so it will not turn further when it reaches the rotation stop position.
Turning the needle too far may cause damage.
- Do not tighten the handle with tools such as nippers.
This can result in breakage due to idle turning.
- Do not over tighten the lock nut.
It is possible to tighten the standard lock nut (hexagon) manually. When tightening further with tools, tighten by approximately 15° to 30°. Over tightening may cause breakage.
- When screwdriver operation type needle is selected as option (E), make sure the lock nut is not loose to prevent the nut from coming off due to vibration.
- Leakage cannot be completely eliminated when the needle is fully closed. A certain amount of leakage is allowed in the products specifications. Tightening the needle to achieve zero leakage may result in equipment damage.

How to Read the Flow Rate Characteristics Graph

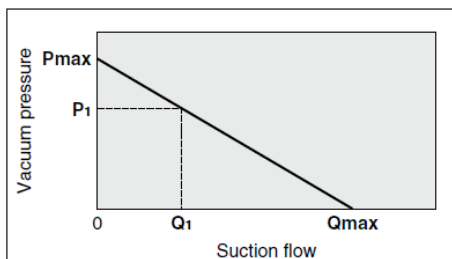

The flow rate characteristics indicate the relationship between the vacuum pressure and the suction flow of the ejector. They also show that when the suction flow changes, the vacuum pressure also changes. In general, this indicates the relationship at the ejector's standard operating pressure. In the graph, **Pmax** indicates the max. vacuum pressure, and **Qmax** indicates the max. suction flow. These are the values that are published as specifications in catalogs, etc. Changes in vacuum pressure are explained in the order below.

- If the ejector's suction port is closed and sealed tight, the suction flow becomes "0," and the vacuum pressure increases to the max. (**Pmax**).
- If the suction port is opened gradually and air is allowed to flow (the air leaks), the suction flow increases, and the vacuum pressure decreases. (The condition of **P1** and **Q1**)
- If the suction port is opened completely, the suction flow increases to the max. (**Qmax**), while the vacuum pressure then drops almost to "0" (atmospheric pressure).

As described above, the vacuum pressure changes when the suction flow changes. In other words, when there is no leakage from the vacuum (V) port, the vacuum pressure can reach its maximum, but as the amount of leakage increases, the vacuum pressure decreases. When the amount of leakage and the maximum suction flow become equal, the vacuum pressure becomes almost zero. When adsorbing workpieces which are permeable, subject to leakage, etc., caution is required as the vacuum pressure will not be very high.

12. Limitations of Use

■ Exhaust

The exhaust resistance should be as small as possible to obtain the full ejector performance. There should be no shield around the exhaust slit for silencer exhaust type. For port exhaust type, ensure that the back pressure does not exceed 5 kPa. Increased back pressure may lead to the reduction of suction flow and the achievable vacuum pressure decreased. Do not operate the vacuum unit or apply pressure to the exhaust port with the exhaust port closed. This increases the pressure in the product and can damage the vacuum unit.

■ Sound absorbing material

If the sound absorbing material is clogged, it will cause a reduction in the vacuum unit performance. Sometimes, if the operating environment contains a lot of particles or mist, the replacement of the filter element only is not enough to recover vacuum performance – as the sound absorbing material may be clogged. Replace the sound absorbing material. (Regular replacement of the filter element and sound absorbing material is recommended.)

■ Exhaust noise

When vacuum unit generates vacuum, noise can be heard from the exhaust port when the standard supply pressure is close to the pressure that generates peak vacuum pressure making vacuum pressure unstable. If the vacuum pressure range is adequate for adsorption, there should not be a problem. If the noise causes a problem or affects the setting of the SI Unit, change the supply pressure slightly to avoid the pressure range of the noise.

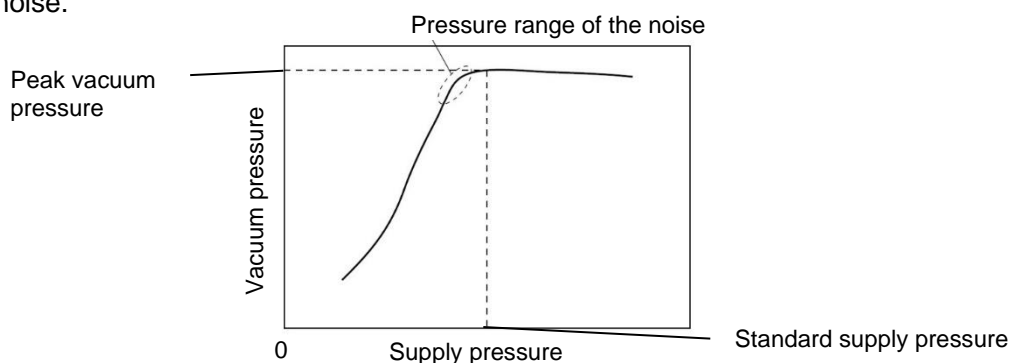

Models with a large nozzle diameter generate a large exhaust noise if the exhaust (EXH) port is opened. Install piping or a silencer to the exhaust port to reduce the exhaust noise.

■ Exhaust air

If solid substances are sucked in through the vacuum (V) port, they will be discharged from the exhaust port at a high speed if the exhaust (EXH) port is opened. Therefore, do not look into the exhaust port or direct the exhaust port toward a person when the vacuum unit is operating.

■ Holding vacuum pressure

Since valves are subject to air leakage, they cannot be used for applications such as holding vacuum pressure in a pressure vessel. SMC can issue no guarantees regarding the maintenance of workpiece adsorption when using check valves. Take separate safety measures to prevent workpieces from dropping in the case of an electrical power outage, etc.

■ Adsorbing the workpiece

When adsorbing the workpiece, ensure to turn on the vacuum instruction signal. The workpiece may drop due to the foreign matter adhering to the vacuum pad or leakage from the valve.

■ Exhaust air flows to the vacuum port

If each exhaust piping for the port exhaust vacuum units is connected and made into centralized piping, the exhausted air will flow back into the exhaust path which is not operating, and will then be exhausted from the vacuum port. Exhaust individually.

13. Troubleshooting

■ Troubleshooting chart

When any malfunction is observed, it is recommended to perform the following troubleshooting.

Failure phenomenon		Possible causes		Countermeasures	
Vacuum absorption failure	Vacuum is not generated	Supply valve does not operate	Decline in the power supply voltage	Refer to (1)	
			Electrical wire failure	Refer to (2) and (3)	
			The supply pressure exceeds the operating pressure range	Refer to (4)	
	Vacuum pressure decreased		Clogging by foreign matter or particles	Refer to (5) and (6)	
			Deterioration of the adsorbing part (pad) and air leakage due to wearing	Refer to (7)	
			Control failure (Simultaneous energization)	Refer to (8)	
			Incorrect assembly during maintenance (Mounting failure of the gasket or O-ring)	Refer to (9)	
		Insufficient supply pressure	Refer to (10)		
		Deformation of the check valve	Refer to (11)		
Fluctuation of vacuum pressure	Noise is generated intermittently when air is exhausted when absorbing by vacuum and vacuum pressure slightly fluctuates	Vibration of fluid when vacuum pressure is generated		Refer to (12)	
Air leakage from vacuum port	Air leakage from the vacuum port when the release valve is OFF	Exhaust air flows to the vacuum port		Refer to (13)	
Vacuum release failure	Release air is not output	Release flow control valve is fully closed		Refer to (14)	
		Release valve does not operate	Decline in the power supply voltage	Refer to (1)	
			Electrical wire failure	Refer to (2) and (3)	
			The supply pressure exceeds the operating pressure range	Refer to (4)	
			Control failure (Simultaneous energization)	Refer to (8)	
	Workpiece is not released smoothly	Decrease of release flow		Refer to (15)	
Adhesion of the workpiece and pad		Refer to (16)			
Operation failure of the pressure switch with energy saving function	Vacuum is not held. Supply valve chatters	Vacuum leakage		Refer to (17)	
		Deformation of the check valve		Refer to (11)	

Countermeasure

No.	Countermeasure
(1)	Adjust the rated voltage so that the supply voltage (PWR and PWR(V)) for the SI Unit is within specification of the rated voltage while the simultaneously energized equipment is ON.
(2)	Check the correct connection of the power supply and wiring of plug connectors.
(3)	The cable with power supply connector and the cable with communication connector will be broken by repeated bending. If the vacuum manifold is installed on a moving part, use the wiring intended for moving parts. Fix the wiring to the device so that it is not affected by vibrations.
(4)	If the supply pressure is lower than the operating pressure range, it may cause operation failure of the main valve. If the supply pressure is higher than the operating pressure range, it may cause operation failure because of the malfunction of the pressure sensor or early defect due to wear of seals. Adjust the supply pressure appropriate for the specification for each port. When vacuum units are generated vacuum simultaneously, consume a large amount of air during operation. Ensure that the supply pressure is within the operating range.
(5)	Oil mist in the supply air or particles in the piping cause clogging if they enter into the vacuum unit. This may cause operation failure. Blow the air piping with air to eliminate particles. It is recommended installing the mist separator and air filter for cleaner supply air. Perform regular maintenance for mist separator and filter. Refer to the product catalogue or operation manual for details of the maintenance.
(6)	Substances adhere to the surface of the workpiece may enter into the vacuum unit, causing clogging. Install an air suction filter with high filtration accuracy in the piping of the pad and vacuum unit against foreign matter in the suction air (fine substances penetrating the built in filter element). Perform regular maintenance for the filter. Refer to the product catalogue or operation manual for details of the maintenance.
(7)	Replace the pad. Revise the absorbing condition based on the relation between the vacuum pressure and workpiece.
(8)	If the release valve is energized while the supply valve operating, it may cause malfunction. Check the control program and wiring.
(9)	The gasket or O-ring that was removed or displaced during filter element maintenance or valve assembly replacement must be put back to the correct position before reassembling in order to avoid the leakage of vacuum or air during operation. If the gasket or O-ring is lost or broken, replace it with a new one.
(10)	If the supply pressure during the operation of the vacuum unit decreases, the generated vacuum pressure decreases. Apply adequate flow rate so that the supply pressure is adequate when other air equipment operating simultaneously.
(11)	If the check valve has a problem, vacuum pressure does not increase adequately. If the vacuum unit is operated while the exhaust port is pressurized or blocked, the check valve becomes deformed and held in the body vacuum path, making sealing impossible. In the following cases, the vacuum pressure does not increase adequately. Replace the vacuum unit. (1) The check valve in the vacuum unit is deteriorated by long-term use. (2) Dirt is adhered to the sealing surface.

No.	Countermeasure
(12)	<p>When adsorbing the workpiece, high speed air coming out of the nozzle collides into the diffuser I.D. and bounces back, generating vibration in the exhaust air. Because of this, the vacuum pressure fluctuates slightly and is not stabilized.</p> <p>There should be no functional problem with the vacuum unit. The phenomenon causes noise or could be a problem for the setting of vacuum switch. The noise can be eliminated by changing the supply pressure.</p> <p>Adjust the pressure regulating valve for supply pressure while checking the exhaust noise and vacuum pressure until the noise disappear.</p> <p>The vacuum unit may generate noise due to the increase of exhaust resistance. When the silencer becomes dirty, the replacement of the silencer element may improve the condition.</p>
(13)	<p>If each exhaust piping for port exhaust vacuum unit is connected and made into a centralized piping, the exhausted air flows back into the vacuum unit exhaust path which is not operating, and then exhausted from the vacuum port. Exhaust individually.</p>
(14)	<p>Release air is not output if the Release flow control valve is fully closed. Adjust the needle in an appropriate position.</p>
(15)	<p>If the suction filter is clogged, relief air passing through the filter decreases. Liquid or fine particles enter into the filter element fibers. Periodic maintenance or installation of an external air suction filter with a large capacity is recommended.</p>
(16)	<p>The vacuum pad surface contacting with the workpiece is deteriorated over the number of contacts. The workpiece may not be contacted correctly if the surface is deteriorated due to the increase of the rubber viscosity. If the rubber viscosity increases, replace the pad.</p>
(17)	<p>The product with energy saving function reduces air consumption by creating a vacuum between the check valve and pad in the vacuum unit while adsorbing the workpiece. This stops the air supply. When the holding vacuum decreases, the supply valve turns on at the previously set threshold to supply vacuum pressure so that the workpiece does not fall.</p> <p>Therefore, if the holding time is very short, highly frequent ON/OFF operation will cause phenomenon like chattering. In this case, improve the leakage or release the setting of energy saving. Refer to the SI Unit (EX260-V□□1) Operation Manual for release method.</p>

Revision history

A: Added contents[April 2022]
B: Added UKCA marked[July 2022]
C: Added specifications[September 2022]
D: Added specifications[February 2023]
E: Added specifications[August 2023]
F: Added specifications[September 2024]

SMC Corporation

Tel: + 81 3 5207 8249 Fax: +81 3 5298 5362

URL <https://www.smcworld.com>

Note: Specifications are subject to change without prior notice and any obligation on the part of the manufacturer.

EtherNet/IP™ is a trademark of ODVA.

EtherCAT® is registered trademark and patented technology, licensed by Beckhoff Automation GmbH, Germany.

©2022 SMC Corporation All Rights Reserved