



Operation Manual

PRODUCT NAME

Vacuum Gripper System

MODEL / Series / Product Number

ZGS*-400240***-*****

SMC Corporation

Contents

Safety Instructions.....	2
1. Parts included in the package	6
2. How to order	7
3. Summary of Product Parts	8
4. Mounting	9
5. Specifications	14
5.1. Specifications.....	14
5.2. Pneumatic Circuit.....	15
5.3. Wiring	16
5.4. Ejector flow characteristics (representative values).....	17
5.5. Ejector Exhaust characteristics (representative values)	18
6. Dimensions	20
6.1. Vacuum Gripper System with robot mounting flange	20
6.2. Vacuum Gripper System with robot mounting flange and offset flange	21
6.3. Vacuum Gripper System without robot mounting flange	22
6.4. Robot mounting flange	23
6.5. Offset flange.....	24
6.6. Tool center point and center of gravity and Weight	25
7. Technical information.....	27
7.1. Theoretical lifting force for each suction area	27
7.2. How to use the pressure switch to confirm gripping	29
7.3. Supply valve and release valve LED lamp indication.....	30
8. Maintenance.....	30
8.1. Maintenance for Vacuum Gripper System	30
8.2. How to replace parts	31
8.2.1 Parts name and parts number	31
8.2.2 How to replace foam with plate	33
8.2.3 How to replace foam.....	34
8.2.4 How to replace Vacuum saving valves.....	36
8.2.5 How to replace Ejector unit.....	37
8.2.6 How to replace Connector cable assembly	40
9. Precautions.....	41
10. Troubleshooting	42



Safety Instructions

These safety instructions are intended to prevent hazardous situations and/or equipment damage. These instructions indicate the level of potential hazard with the labels of “**Caution**,” “**Warning**” or “**Danger**.” They are all important notes for safety and must be followed in addition to International Standards (ISO/IEC^{*1)}, and other safety regulations.

*1) ISO 4414: Pneumatic fluid power - General rules and safety requirements for systems and their components
ISO 4413: Hydraulic fluid power - General rules and safety requirements for systems and their components
IEC 60204-1: Safety of machinery - Electrical equipment of machines - Part 1: General requirements
ISO 10218-1: Robots and robotic devices - Safety requirements for industrial robots - Part 1: Robots
etc.



Danger

Danger indicates a hazard with a high level of risk which, if not avoided, will result in death or serious injury.

Warning

Warning indicates a hazard with a medium level of risk which, if not avoided, could result in death or serious injury.

Caution

Caution indicates a hazard with a low level of risk which, if not avoided, could result in minor or moderate injury.

Warning

1. The compatibility of the product is the responsibility of the person who designs the equipment or decides its specifications.

Since the product specified here is used under various operating conditions, its compatibility with specific equipment must be decided by the person who designs the equipment or decides its specifications based on necessary analysis and test results. The expected performance and safety assurance of the equipment will be the responsibility of the person who has determined its compatibility with the product. This person should also continuously review all specifications of the product referring to its latest catalog information, with a view to giving due consideration to any possibility of equipment failure when configuring the equipment.

2. Only personnel with appropriate training should operate machinery and equipment.

The product specified here may become unsafe if handled incorrectly. The assembly, operation and maintenance of machines or equipment including our products must be performed by an operator who is appropriately trained and experienced.

3. Do not service or attempt to remove product and machinery/equipment until safety is confirmed.

1. The inspection and maintenance of machinery/equipment should only be performed after measures to prevent falling or runaway of the driven objects have been confirmed.
2. When the product is to be removed, confirm that the safety measures as mentioned above are implemented and the power from any appropriate source is cut, and read and understand the specific product precautions of all relevant products carefully.
3. Before machinery/equipment is restarted, take measures to prevent unexpected operation and malfunction.

4. Our products cannot be used beyond their specifications. Our products are not developed, designed, and manufactured to be used under the following conditions or environments. Use under such conditions or environments is not covered.

1. Conditions and environments outside of the given specifications, or use outdoors or in a place exposed to direct sunlight.
2. Use for nuclear power, railways, aviation, space equipment, ships, vehicles, military application, equipment affecting human life, body, and property, fuel equipment, entertainment equipment, emergency shut-off circuits, press clutches, brake circuits, safety equipment, etc., and use for applications that do not conform to standard specifications such as catalogs and operation manuals.
3. Use for interlock circuits, except for use with double interlock such as installing a mechanical protection function in case of failure. Please periodically inspect the product to confirm that the product is operating properly.



Safety Instructions

Caution

We develop, design, and manufacture our products to be used for automatic control equipment, and provide them for peaceful use in manufacturing industries. Use in non-manufacturing industries is not covered.

Products we manufacture and sell cannot be used for the purpose of transactions or certification specified in the Measurement Act.

The new Measurement Act prohibits use of any unit other than SI units in Japan.

Limited warranty and Disclaimer/Compliance Requirements

The product used is subject to the following "Limited warranty and Disclaimer" and "Compliance Requirements". Read and accept them before using the product.

Limited warranty and Disclaimer

1. The warranty period of the product is 1 year in service or 1.5 years after the product is delivered, whichever is first.*2)

Also, the product may have specified durability, running distance or replacement parts. Please consult your nearest sales branch.

2. For any failure or damage reported within the warranty period which is clearly our responsibility, a replacement product or necessary parts will be provided.

This limited warranty applies only to our product independently, and not to any other damage incurred due to the failure of the product.

3. Prior to using SMC products, please read and understand the warranty terms and disclaimers noted in the specified catalog for the particular products.

***2) Suction cups are excluded from this 1 year warranty.**

A suction cup is a consumable part, so it is warranted for a year after it is delivered.



Also, even within the warranty period, the wear of a product due to the use of the suction cup or failure due to the deterioration of rubber material are not covered by the limited warranty

Compliance Requirements

1. The use of SMC products with production equipment for the manufacture of weapons of mass destruction (WMD) or any other weapon is strictly prohibited.

2. The exports of SMC products or technology from one country to another are governed by the relevant security laws and regulations of the countries involved in the transaction. Prior to the shipment of a SMC product to another country, assure that all local rules governing that export are known and followed.









■ Explanation of Symbols

Symbol	Definition
	Things you must not do. Instructions are provided as a drawing or sentence next to the symbol.
	Things you must do Instructions are provided as a drawing or sentence next to the symbol.



■ Operator

1. This Operation Manual is intended for those who have knowledge of machinery using pneumatic equipment, and have sufficient knowledge of assembly, operation and maintenance of such equipment.
Only those persons are allowed to perform assembly, operation and maintenance.
2. Read and understand this Operation Manual carefully before assembling, operating or providing maintenance to the product.

■ Safety Instructions

 Warning	
 Disassembly prohibited	Do not disassemble, modify (including the replacement of board) or repair other than instructed in this manual. Otherwise, an injury or failure can result.
 Do not	Do not operate the product outside of the specifications. Do not use for flammable or harmful fluids. Fire, malfunction, or damage to the product can result. Please check the specifications before use.
 Do not	Do not use in an atmosphere containing flammable or explosive gases. Fire or an explosion can result. The product is not designed to be explosion proof.
 Do not	Do not use the product in a place where static electricity is a problem. Otherwise failure or malfunction of the system can result.
 Do not	Do not cut off the power and compressed air supplied to this product while it is operating. Otherwise it can cause injury due to dropping of workpieces or damage to the system.
 Instruction	If using the product in an interlocking circuit - Provide a double interlocking system, for example a mechanical system. - Check the product for proper operation. Otherwise malfunction can result, causing an accident.
 Instruction	The following instructions must be followed during maintenance - Turn off the power supply - Stop the air supply, exhaust the residual pressure in piping and verify that the air is released before performing maintenance work. It may cause an injury.

Caution

 Do not touch	<p>Do not touch the terminals and connectors while the power is on. Otherwise electric shock, malfunction or damage to the switch can result.</p>
 Instruction	<p>Perform sufficient trial run. Otherwise, injury or damage to the system can result due to suction failure depending on the conditions of the suction of the workpiece. Perform sufficient verification before using this product.</p>
 Instruction	<p>After maintenance is complete, perform appropriate functional inspections and leak test. Stop operation if the equipment does not function properly or there is leakage of fluid. If there is leakage from parts other than the piping, the product might be broken. Cut off the power supply and stop the fluid supply. Do not supply fluid if there is leakage. Safety cannot be assured in the case of an unexpected malfunction.</p>

■ Precautions for Handling

Follow the instructions given below for selecting and handling of the vacuum gripper system.

Product specifications

- Ensure to provide enough space for maintenance.
Design the system allowing the required space for maintenance.
- Use the specified voltage. Otherwise, failure or malfunction can result.
- Design the product to prevent reverse current when the circuit is opened, or the product is forced to operate for operational check. Reverse current can cause malfunction or damage the product.

Operating environment

- Do not use the product in environments where the following atmospheres exist:
 1. Corrosive gases, chemicals, sea water, water, water stream, or where there is contact with any of these
 2. Flammable gases or explosive gases
 3. Oil or chemicals
 4. Thermal cycles other than normal temperature changes
 5. Direct sunlight (ultraviolet rays) or outdoor
 6. Ambient temperature exceeds the operating temperature range (refer to the specification table)
 7. A source of heat, causing radiant heat
- Do not use the product in an area where surges are generated.
When there are machines or equipment that generate a large surge near the product (magnetic type lifter, high frequency inductive furnace, motor, etc.), this can result in deterioration and damage of the internal elements. Take measures against the surge sources and prevent the lines from coming into close contact.
- Do not use the product in an area where a strong magnetic field or strong electric field is generated; this can result in damage to internal parts and product malfunction.
- Do not allow oil, moisture, particles, dust, cutting chips, spatter, or other foreign objects to enter inside the product; this can result in deterioration in product performance or malfunction. Provide appropriate protection when using the product in an environment where contamination may occur.
- Do not apply vibration or impact to the product. Handle the product with care as vibration and impact may cause deterioration in product performance or malfunction.

1. Parts included in the package

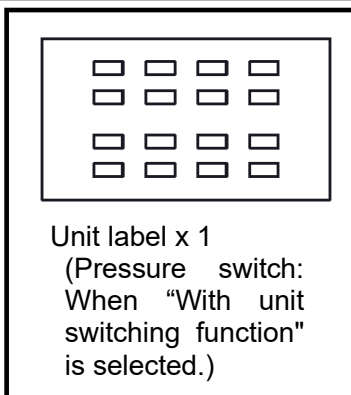
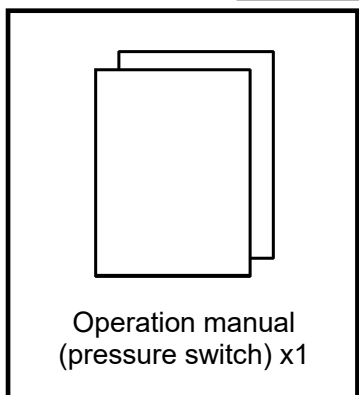
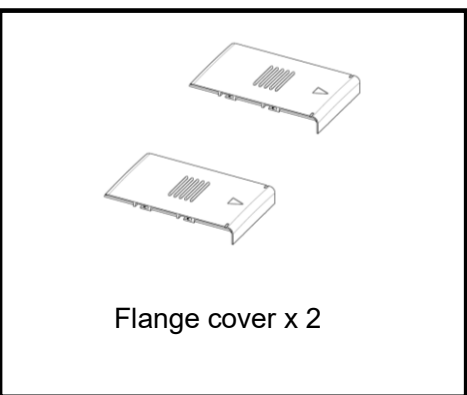
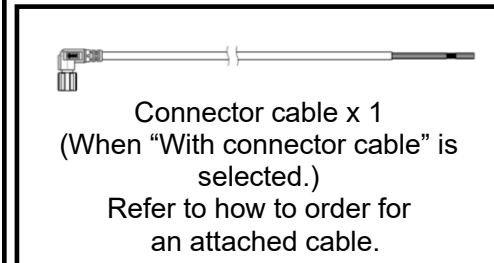
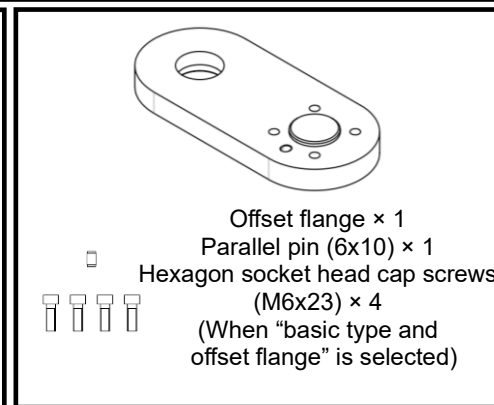
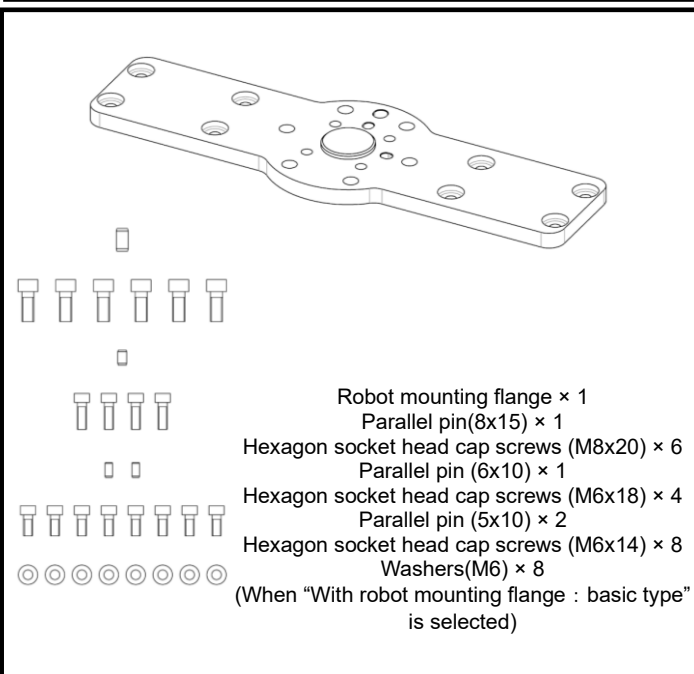
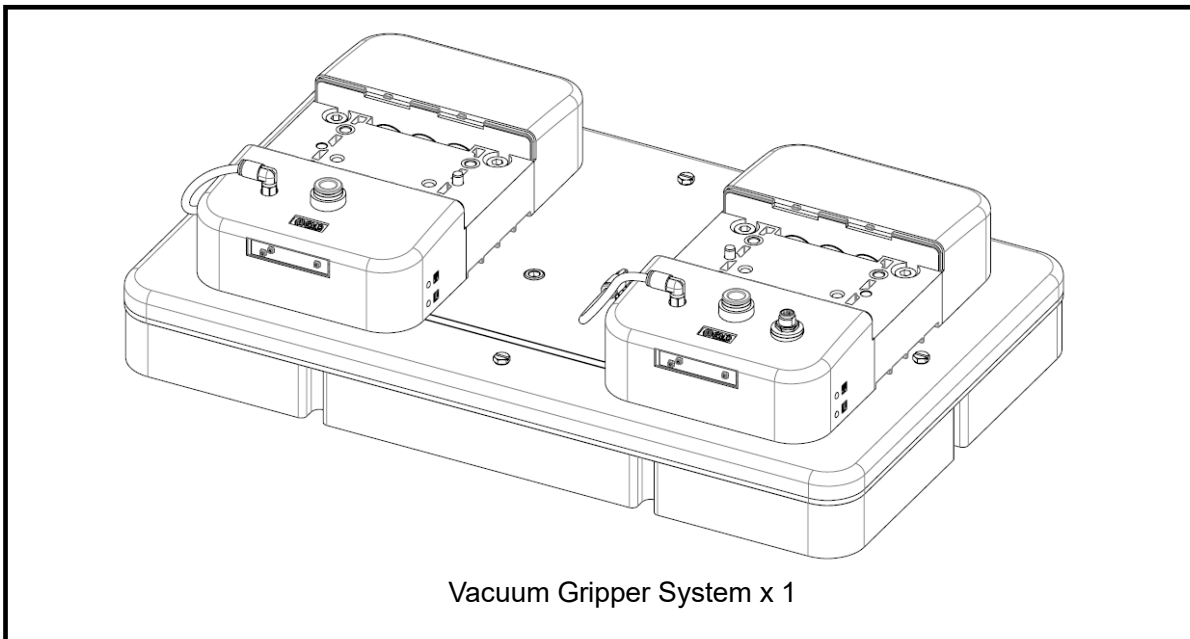

2. How to order

How to order

ZGS **NP** **K** - **400240** **B** **S** **4** - **R** **M** **1** **C8**

①
②
③
④
⑤
⑥
⑦
⑧
⑨
⑩

① Compatible Robot

Symbol		Robot manufacturer	Supported models	Switch output	Valve polarity
Identification symbol	Output type				
N	P	-	General purpose	PNP	-COM
	N			NPN	+COM
011	P	UNIVERSAL ROBOTS	UR10e	PNP	-COM
012			UR16e		
	UR20				
021	N	OMRON TECHMAN ROBOT	TM12(S)	NPN	+COM
			TM14(S)		
			TM16		
			TM20		
TM25S					
043	P	YASKAWA Electric	MOTOMAN-HC10(S)DTP	PNP	-COM
			MOTOMAN-HC20(S)DTP		
	N		MOTOMAN-HC10(S)DTP	NPN	+COM
			MOTOMAN-HC20(S)DTP		
051	P	FANUC	CRX-10iA(L)	PNP	-COM
			CRX-20iA		
			CRX-25iA		

② Combination of supply valve and release valve

Symbol	Supply valve	Release valve
B	N.O.	N.C.
K	N.C.	N.C.
Nil	None	None

③ Foam size

400240	400mmx240mm
--------	-------------

④ Foam

A	Thickness 20mm, Number of hole 91pcs
B	Thickness 30mm, Number of hole 91pcs

⑤ Suction plate

S	Vacuum saving valve type
M	Fixed orifice type

⑥ Number of Ejectors assemblies

2	2pcs
4	4pcs
6	6pcs

Total number of 2 Ejector unit

⑦ Connector cable for compatible robot

Nil*	With connector cable(For compatible models)
R	With connector cable(Discrete wire)
N	Without connector cable

* When "identification symbol: N" is selected in ① Compatible robot, "Nil:With cable (For compatible models)" cannot be selected.

⑧ Pressure switch unit specifications

Symbol	Switch unit
C	With unit switching function
M	SI unit only

※ Under the New Measurement Act, switches with the unit switching function are not permitted for use in Japan. (Only Symbol:M can be selected in Japan.)

⑨ Robot mounting flange

Nil	Without robot mounting flange
1	Basic type(Comforming to ISO 9409-1-50-4-M6)
2	Basic type(Comforming to ISO 9409-1-50-4-M6) and offset flange

Symbol2 can be selected, when compatible robot is "021N" only.

⑩ Air pressure supply (P) port

C8	Metric	Φ8 One-touch fitting
C10		Φ10 One-touch fitting
N9	Inch	Φ5/16" One-touch fitting
N11		Φ3/8" One-touch fitting

3. Summary of Product Parts

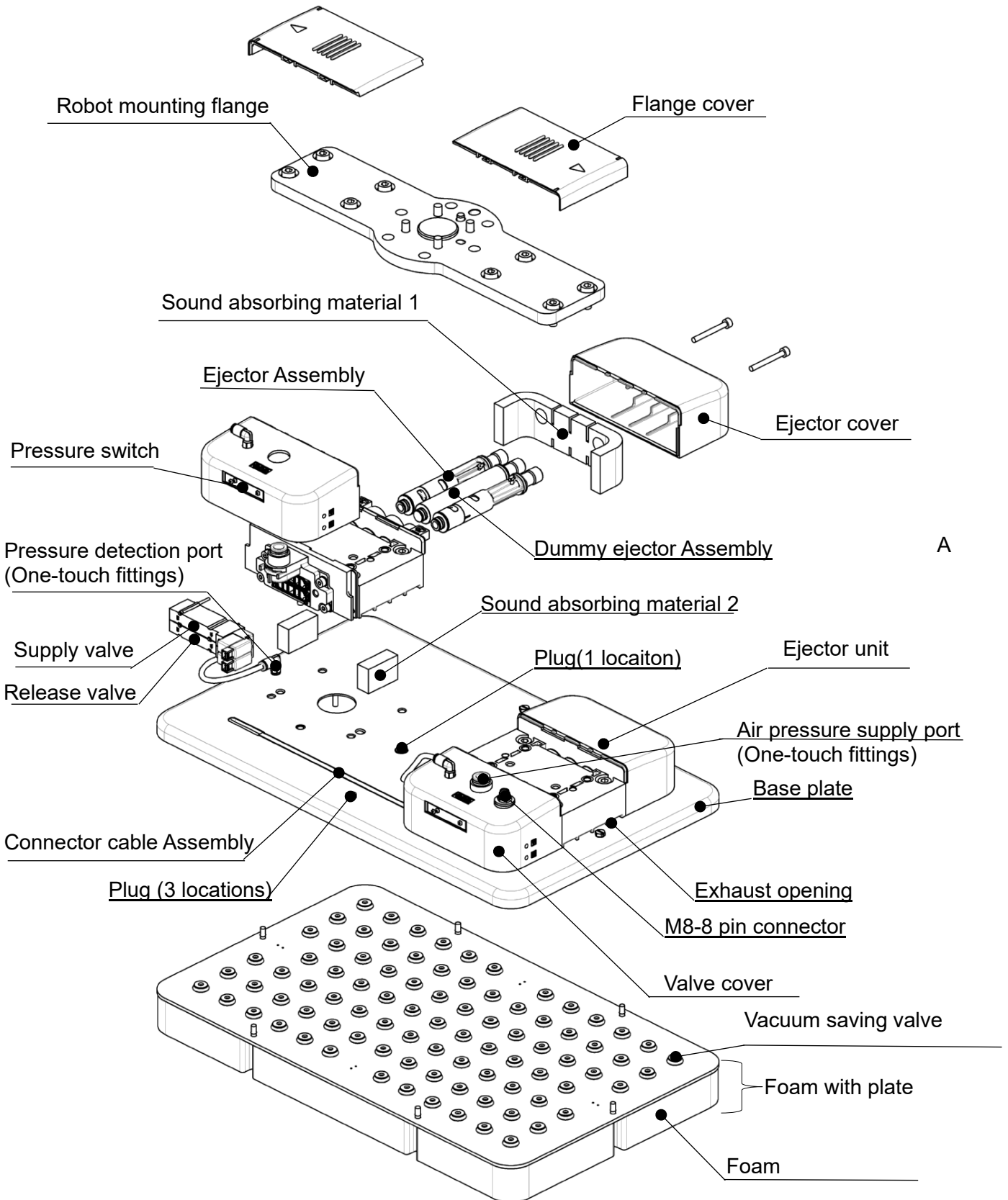

Shows the parts configuration for ZGS**(B,K)-400240*S4-**1*

4. Mounting

■ Mounting the vacuum gripper system on the robot

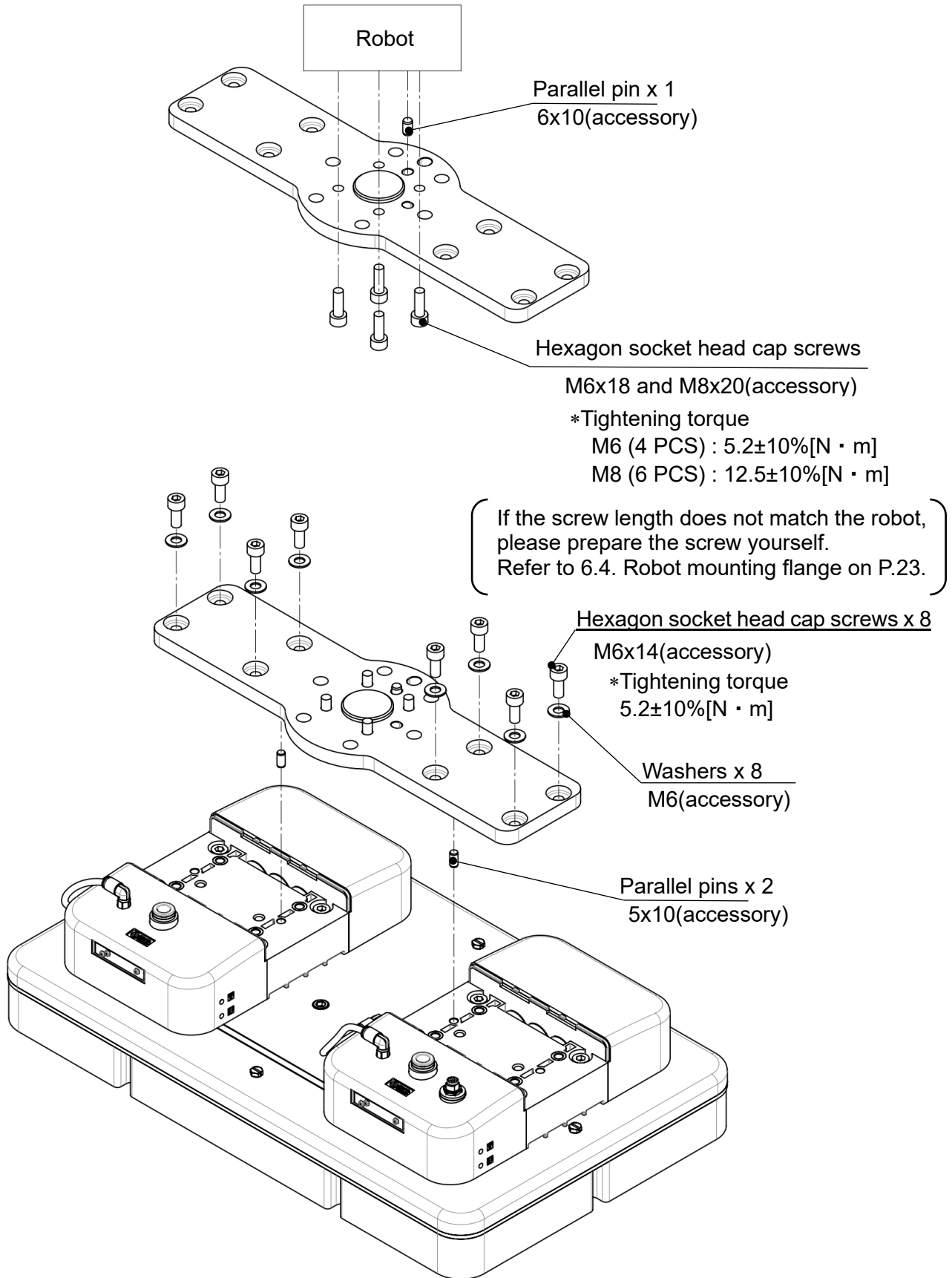

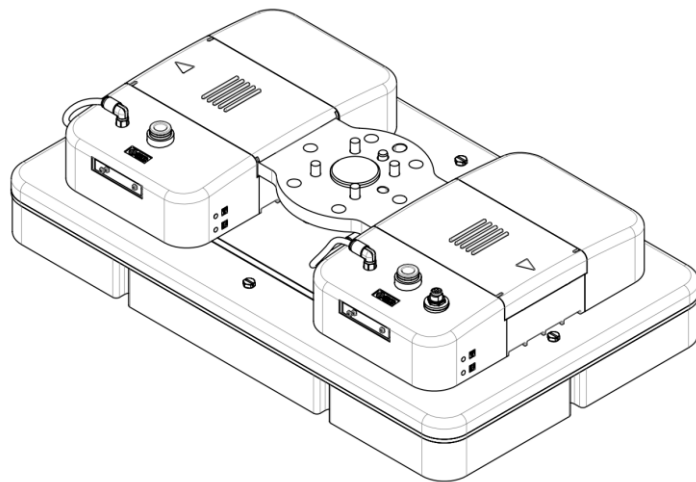
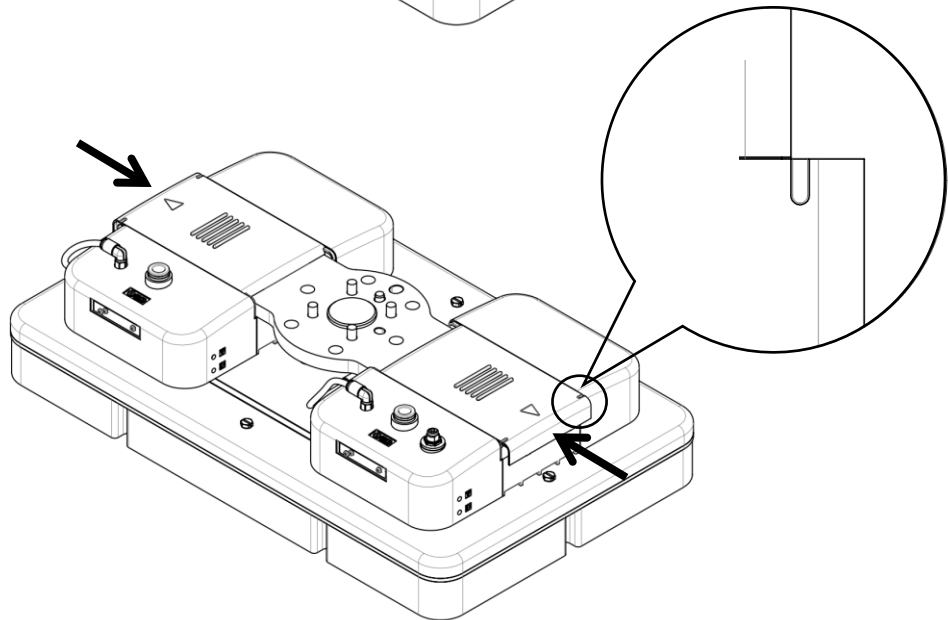
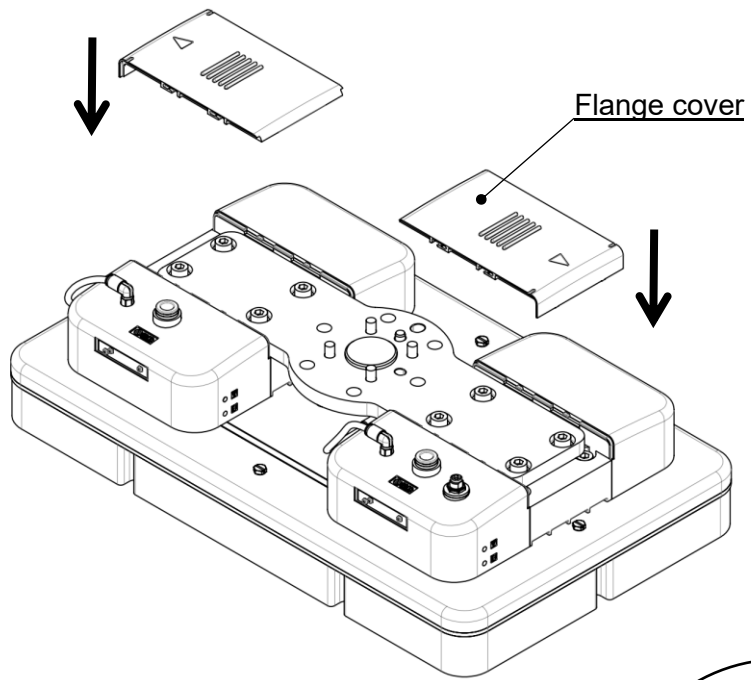

■ Mounting the vacuum gripper system on the robot (With offset flange)

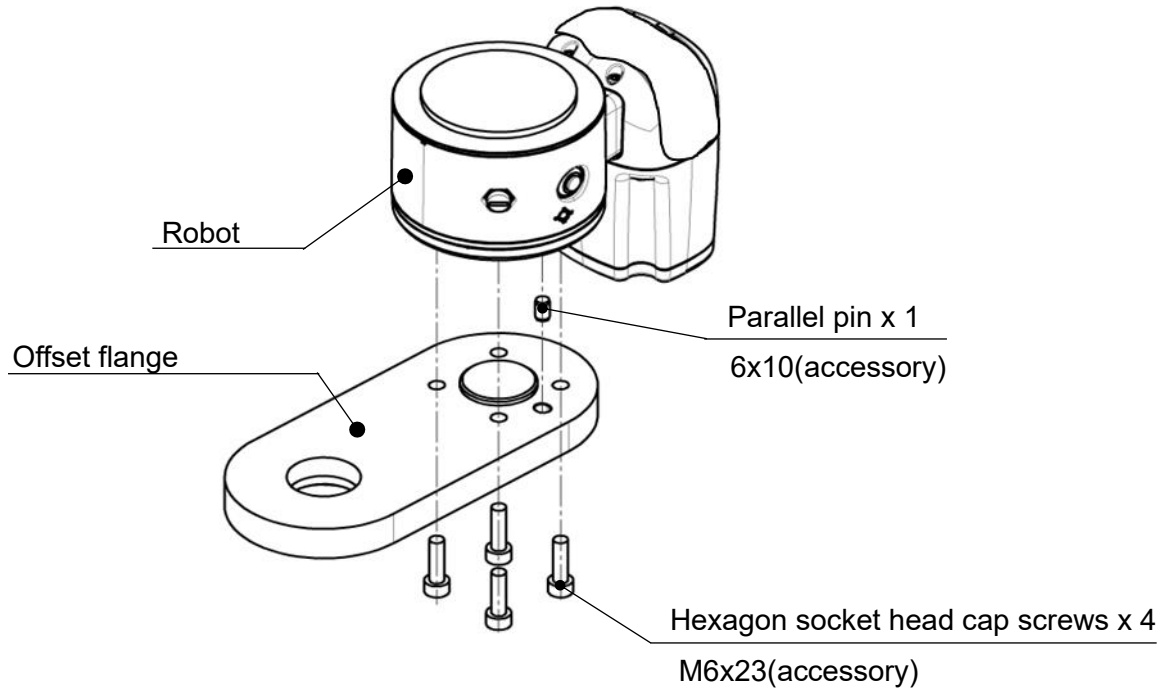

*If the screw length does not match the robot, please prepare the screw yourself.

*Tightening torque
M6 : $5.2 \pm 10\%$ [N · m]

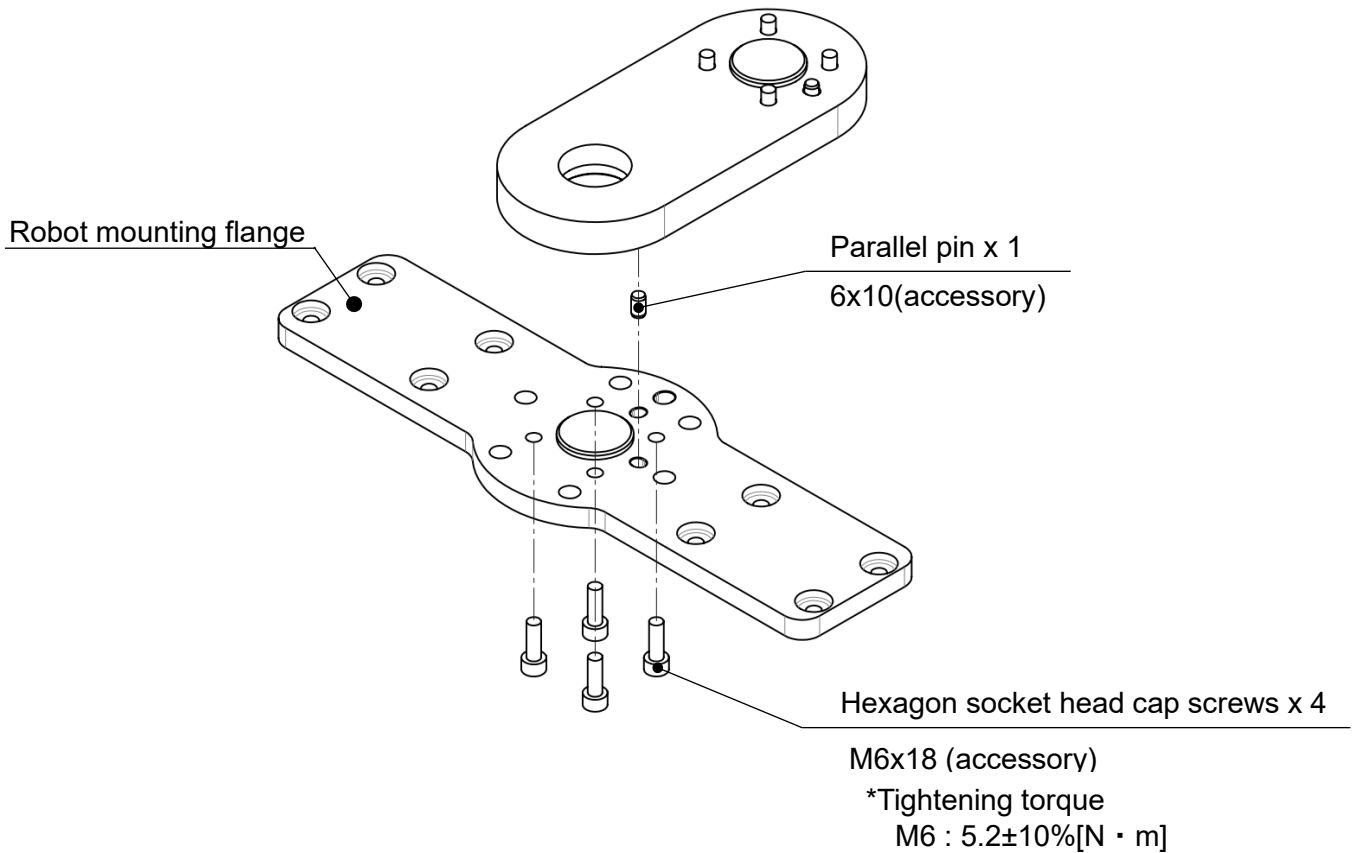

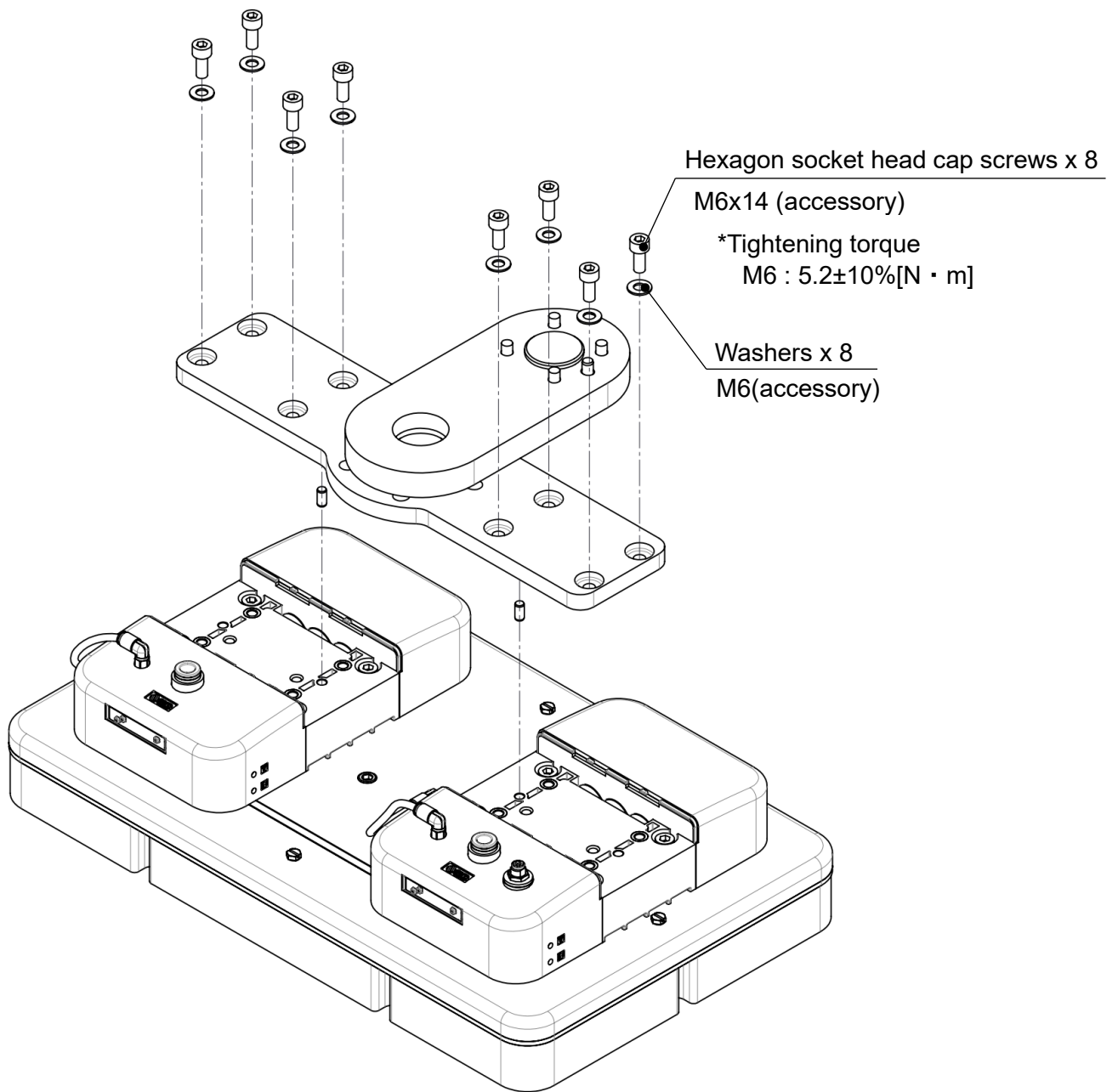

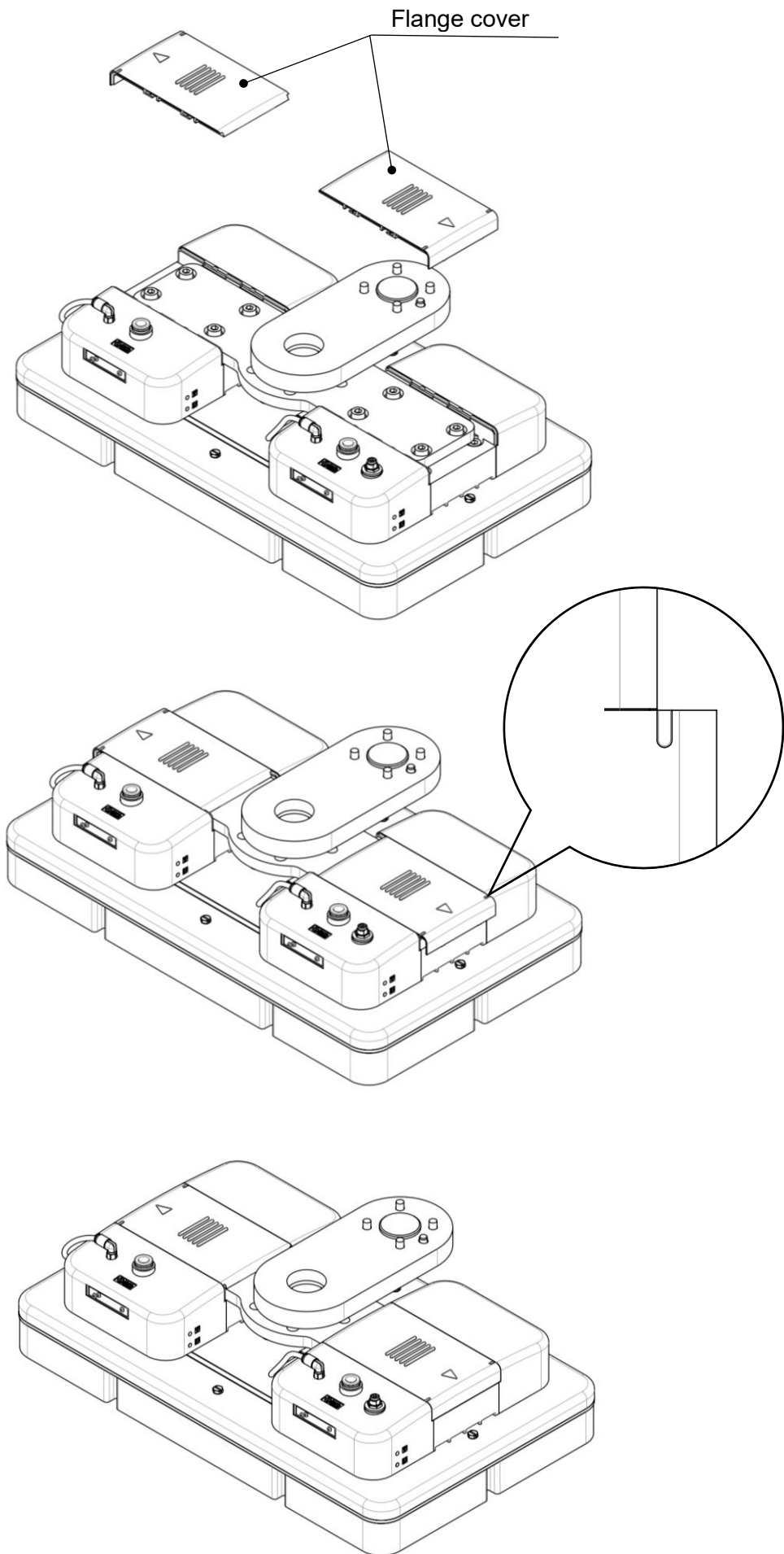

5. Specifications

5.1. Specifications

■ Product specification table

Table 1.

Number of ejectors assemblies [pcs]	2	4	6	
Fluid	Air			
Operating pressure range [MPa]	0.3~0.7			
Operating temperature range [°C]	5~50			
Standard supply pressure [MPa] ^{*1)}	0.58	0.6	0.6	
Max. vacuum pressure [kPa]	-75			
Air consumption [L/min(ANR)] ^{*2)}	228	454	661	
Suction flow [L/min(ANR)] ^{*2)}	-50 kPa	80	172	250
	maximum ^{*3)}	322	646	1022
Weight [kg] ^{*4)}	3.9			
Power supply voltage [V]	DC24±10%			
Power consumption [W]	2.7			
Exhaust noise [dB(A)] or less ^{*5)}	70			
Supply valve Release valve ^{*6)}	JSY3140-5MOZ- * equivalent			
Pressure switch	ZSE10-00-* equivalent			
standard	CE/UKCA MARKED			

*1) Indicates the pressure right before the supply pressure P port when a vacuum is generated.

It is affected by air supply capacity, pipe size, air consumption of other equipment operating simultaneously, etc.

During vacuum generation, the pressure immediately before the P port may fall below the standard supply pressure.

*2) Values are based on our measurement conditions at standard supply pressure and may vary depending on atmospheric pressure (weather, altitude, etc.) and measurement method.

*3) The maximum suction flow rate is an estimated value based on actual measurements under our measurement conditions (not a guaranteed value)

*4) In case of ZGSNPK-400240BS4-RM1C8

*5) Actual values measured under our measurement conditions (not guaranteed values).

*6) Refer to the JSY3000 series catalog for the specifications of the supply valve and release valve.

*7) Refer to the ZSE10 series catalog for pressure switch specifications.

5.2. Pneumatic Circuit

With valve

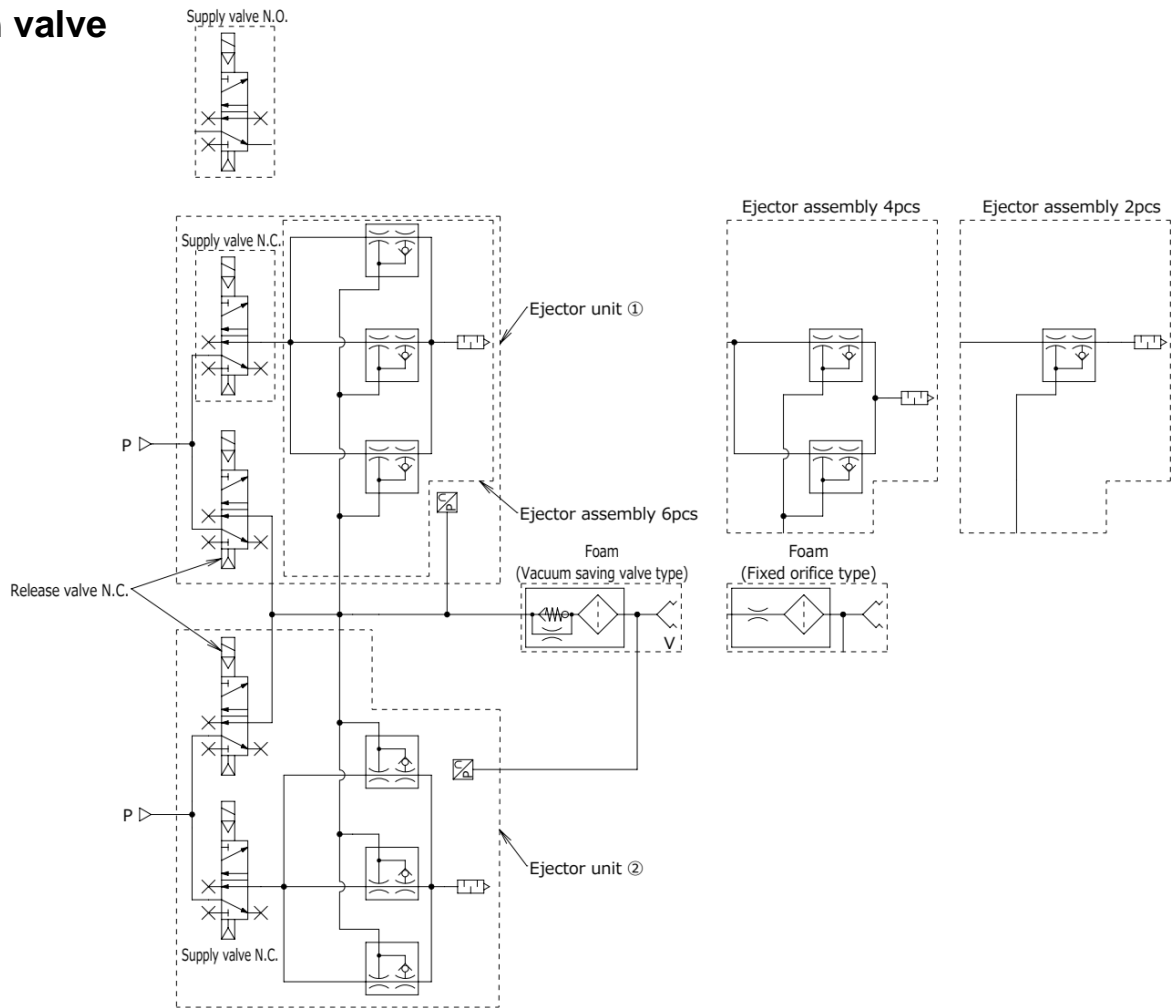

Without valve

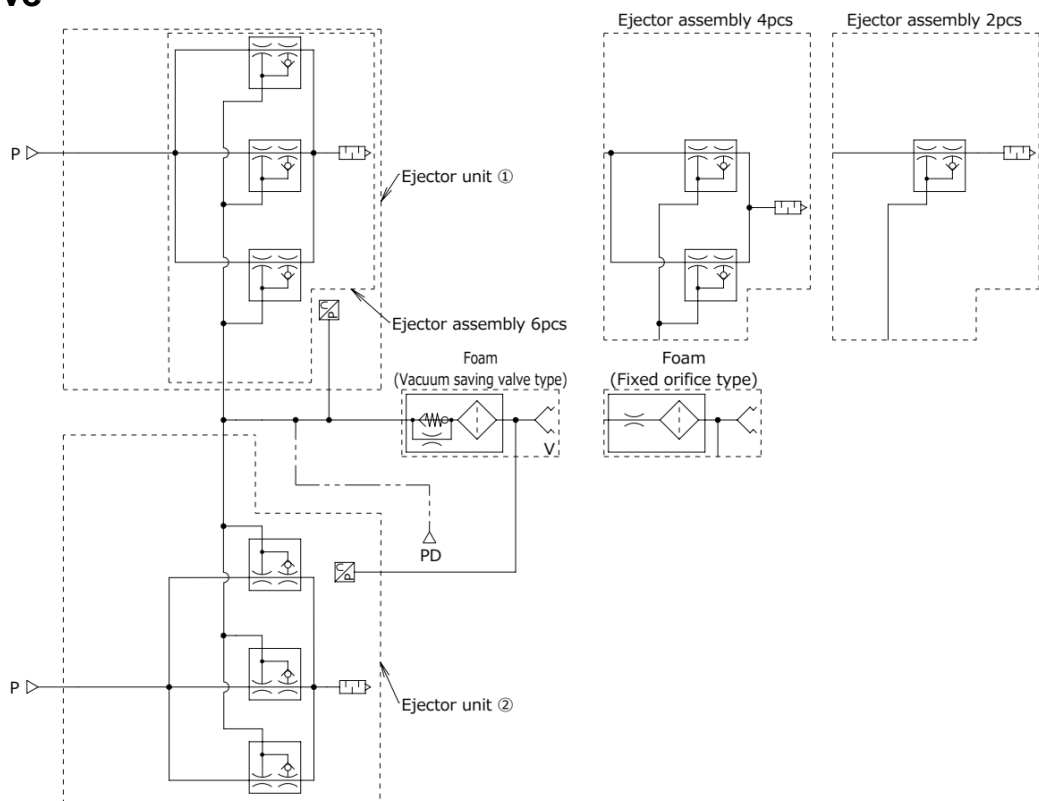

5.3. Wiring

■ Mounting the M8 connector cable

Connect the vacuum gripper system's M8 connector pin and the tool flange's tool I/O connector together with the M8 connector cable.

Do not energize while securing the connector.
Check that the connector is not loose.

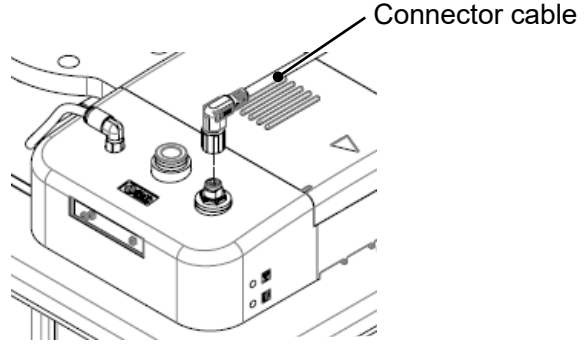

■ Connector cable

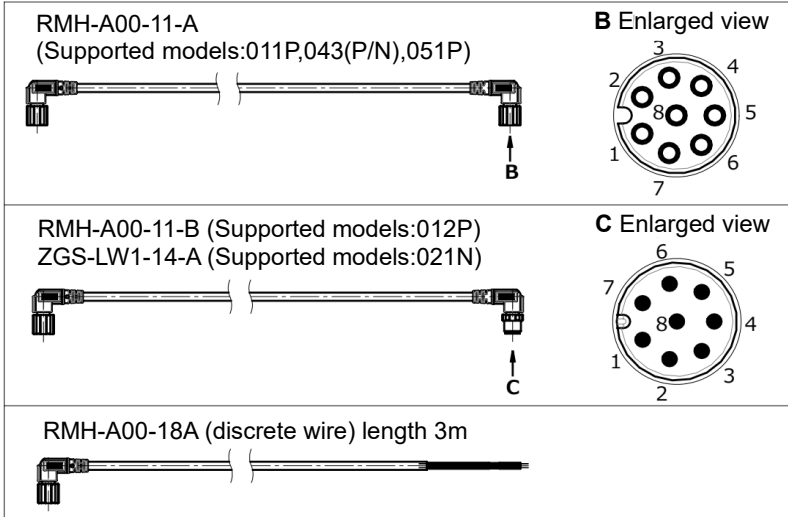

Symbol	Robot manufacturer	Vacuum gripper system side	Robot side	Product number.	Cable length [mm]	
011P	UNIVERSAL ROBOTS	M8 pin connector (socket)	M8-8 pin connector (socket)	RMH-A00-11-A	220	
012P			M8-8 pin connector (plug)	RMH-A00-11-B	160	
043P	YASKAWA Electric		M8-8 pin connector (socket)	RMH-A00-11-A	220	
043N						
051P	FANUC					
NP	-			Discrete wire	RMH-A00-18A	3000
NN						
021N	OMRON TECHMAN ROBOT		M8-8 pin connector (plug)	ZGS-LW1-14-A	300	

Table2. Connector pin assign

Pin no.	Lead wire color of discrete wire	UNIVERSAL ROBOTS FANUC YASKAWA Electric	YASKAWA Electric	OMRON TECHMAN ROBOT
		PNP type	NPN type	
1	White	-	-	Power supply voltage (DC24V) (+)
2	Brown	-	-	Pressure switch 1 output (OUT1) 【Digital】 (+)
3	Green	Pressure switch 2 output (OUT1) 【Digital】 (-)	Pressure switch 2 output (OUT1) 【Digital】 (+)	Pressure switch 2 output (OUT1) 【Digital】 (+)
4	Yellow	Pressure switch 1 output (OUT1) 【Digital】 (-)	Pressure switch 1 output (OUT1) 【Digital】 (+)	-
5	Gray	Power supply voltage (DC24V) (+)	Power supply voltage (DC24V) (+)	Supply valve (-) *1)
6	Black	Release valve (+) *1)	Release valve (-) *1)	Release valve (-) *1)
7	Blue	Supply valve (+) *1)	Supply valve (-) *1)	-
8	Red	Power supply voltage (GND) (-)	Power supply voltage (GND) (-)	Power supply voltage (GND) (-)

*1) In case of without valve, it is not connected.

Refer to the operation manual for how to use the pressure switch ZSE10.

5.4. Ejector flow characteristics (representative values)

*Flow characteristics are values at standard supply pressure.

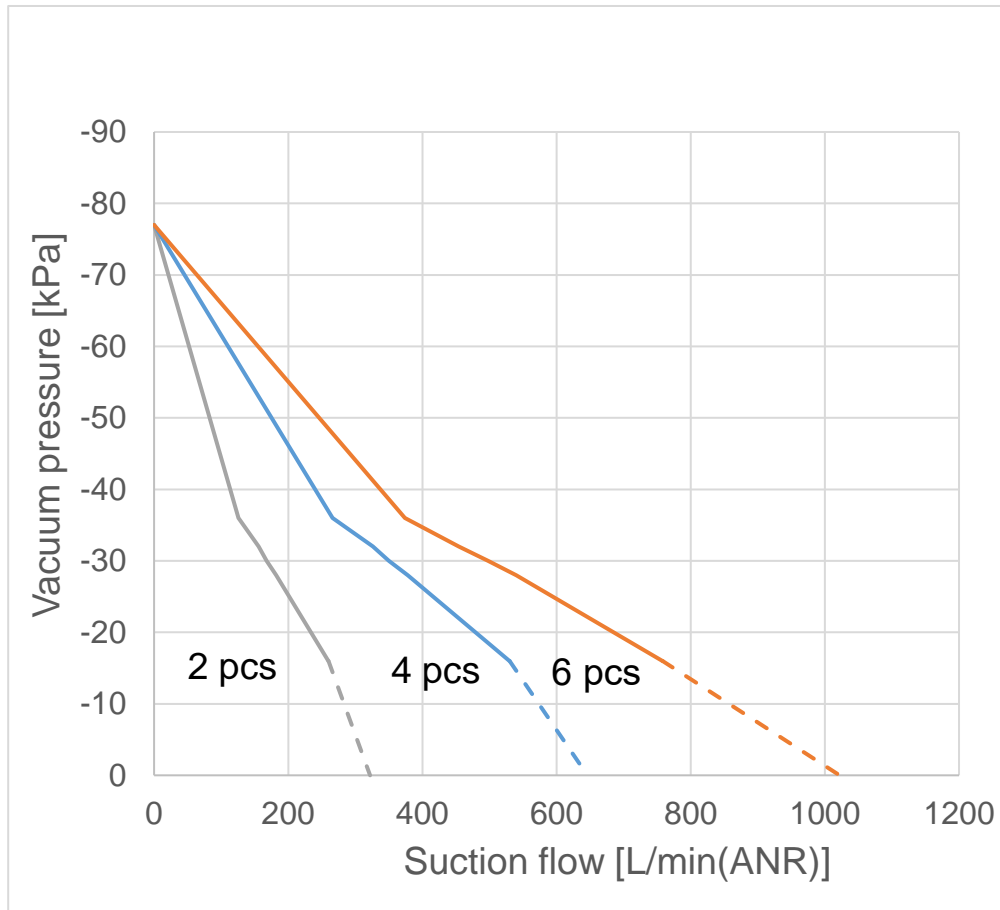
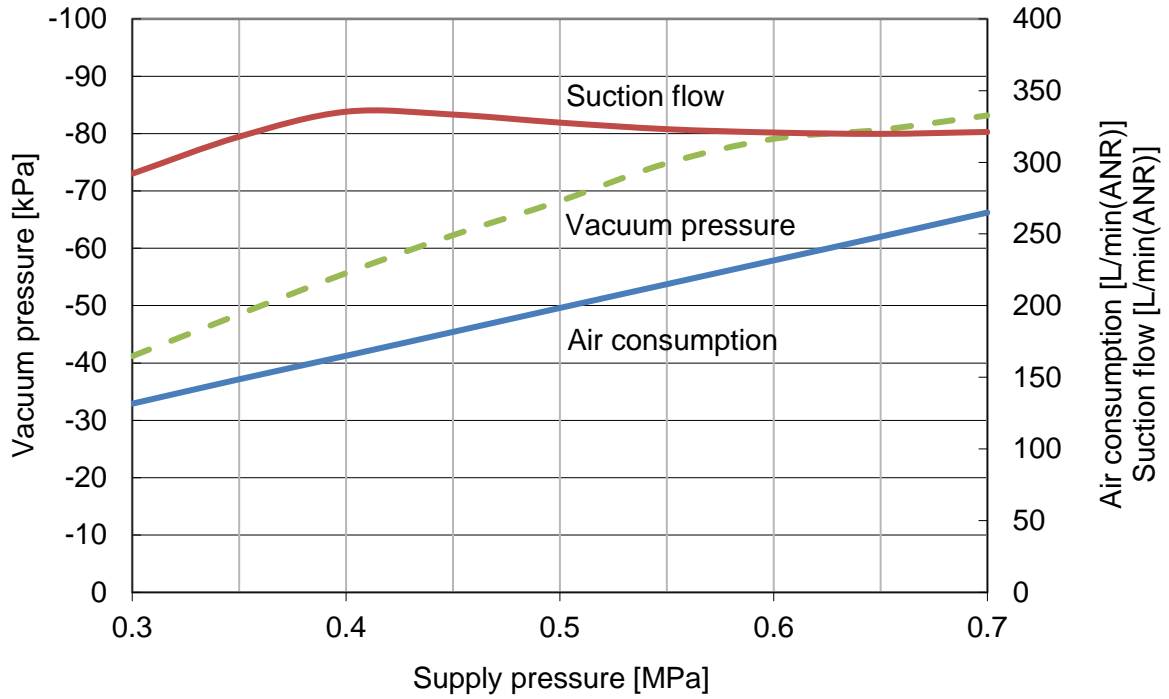

Table3. Air consumption/suction flow for each number of ejectors assemblies (representative values)

Number of ejectors assemblies [pcs]	Supply pressure [MPa]	Air consumption [L/min(ANR)]	Suction flow [L/min(ANR)] for each vacuum pressure [kPa]								Max. vacuum pressure [kPa]
			0	-10	-20	-30	-40	-50	-60	-70	
2	0.58	228	322	286	238	168	110	80	46	22	-75
4	0.6	454	646	574	490	350	222	172	104	54	
6	0.6	661	1022	864	706	498	338	250	144	66	

5.5. Ejector Exhaust characteristics (representative values)

When number of ejectors assemblies are 2 pcs,



When number of ejectors assemblies are 4 pcs,

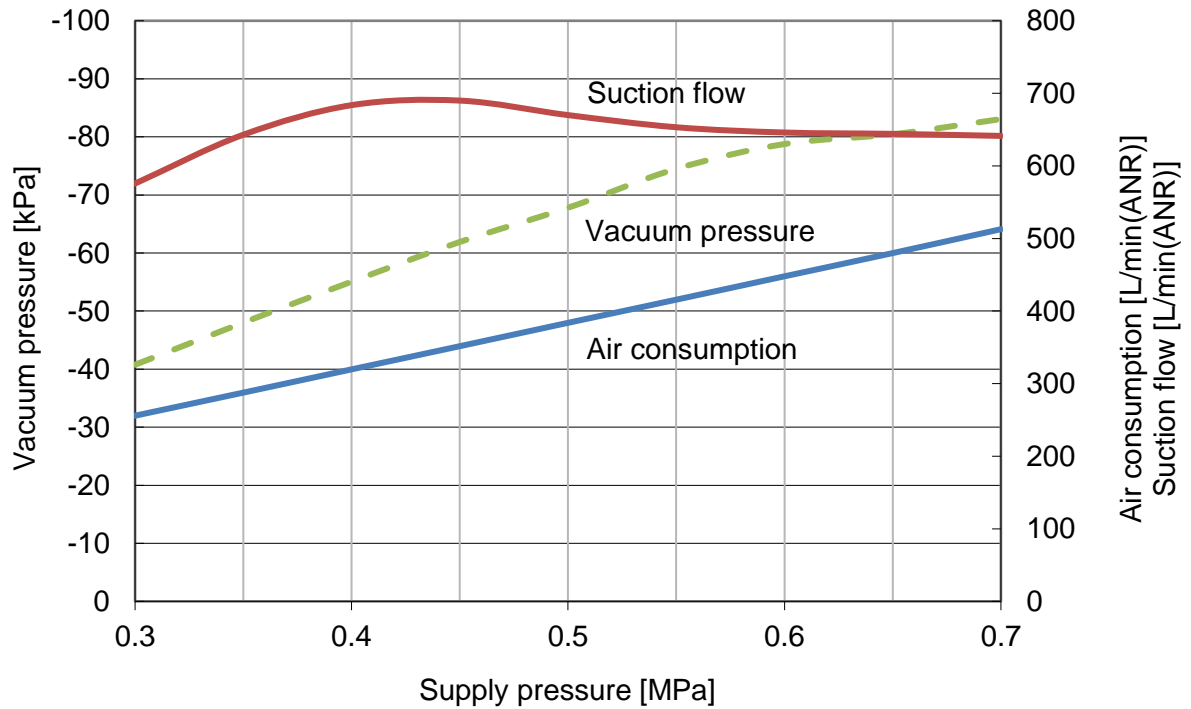

When number of ejectors assemblies are 6 pcs,

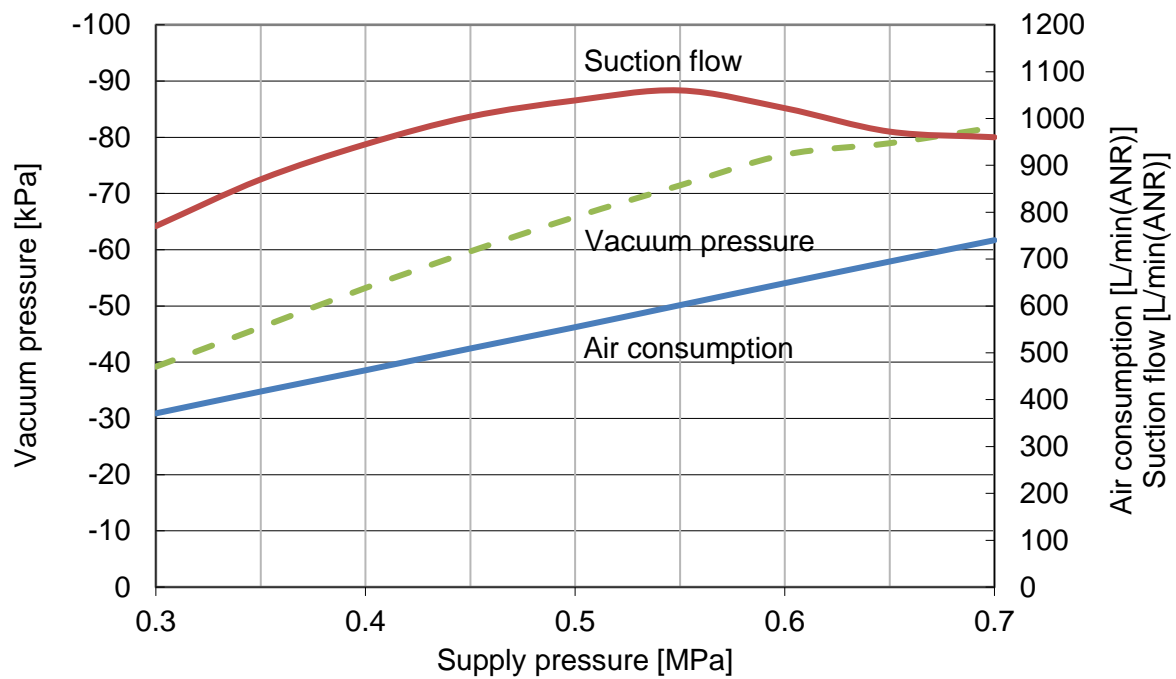

6. Dimensions

6.1. Vacuum Gripper System with robot mounting flange

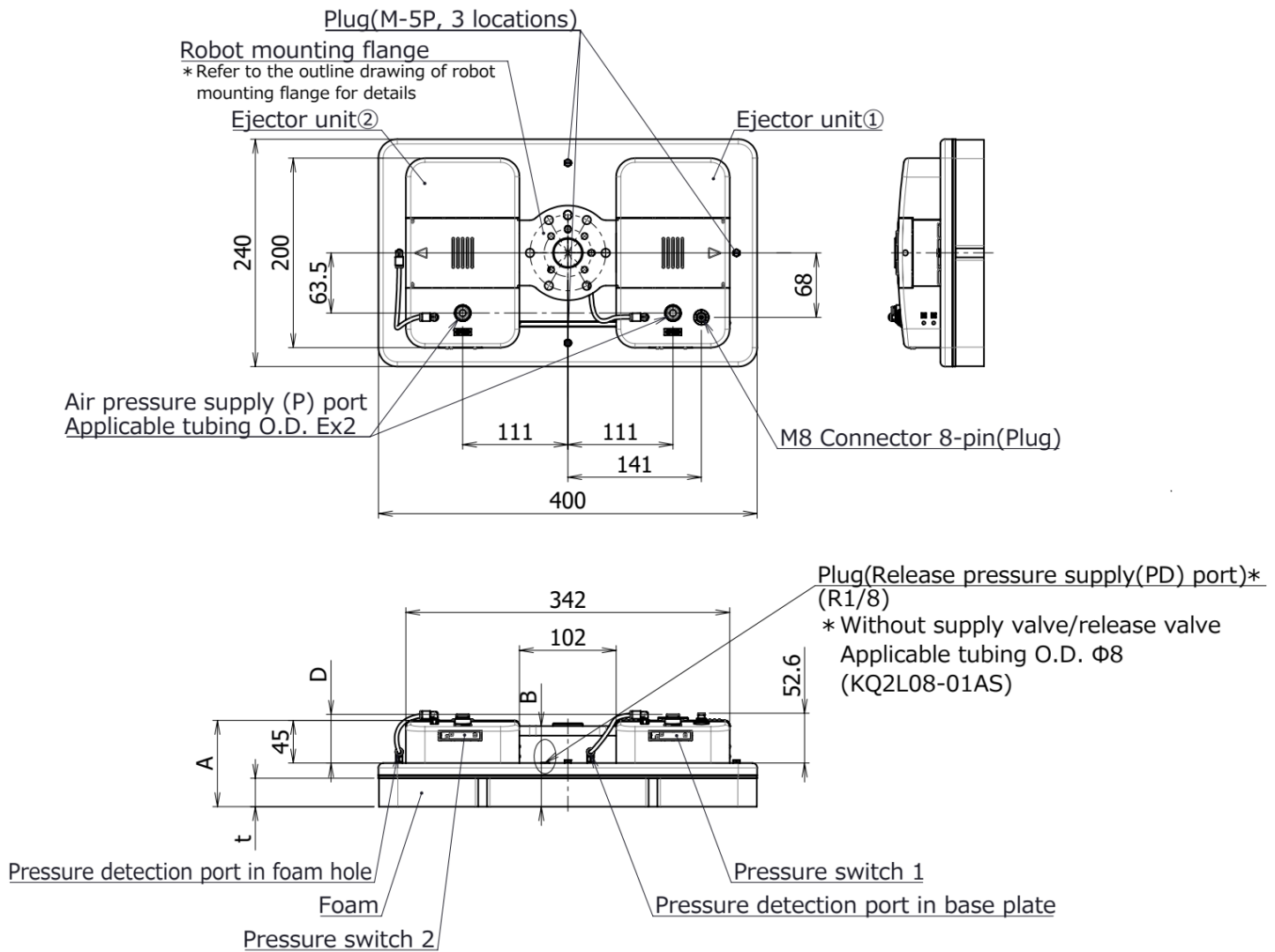

Table4-1. Dimensions

Order no.	t	A	B
ZGS***-400240A***-****	20	81	75
ZGS***-400240B***-****	30	91	85

Order no.	D	E
ZGS***-400240***-****C8	51.4	$\phi 8$
ZGS***-400240***-****C10	52	$\phi 10$
ZGS***-400240***-****N9	51.4	$\phi 5/16$ "
ZGS***-400240***-****N11	51.9	$\phi 3/8$ "

6.2. Vacuum Gripper System with robot mounting flange and offset flange

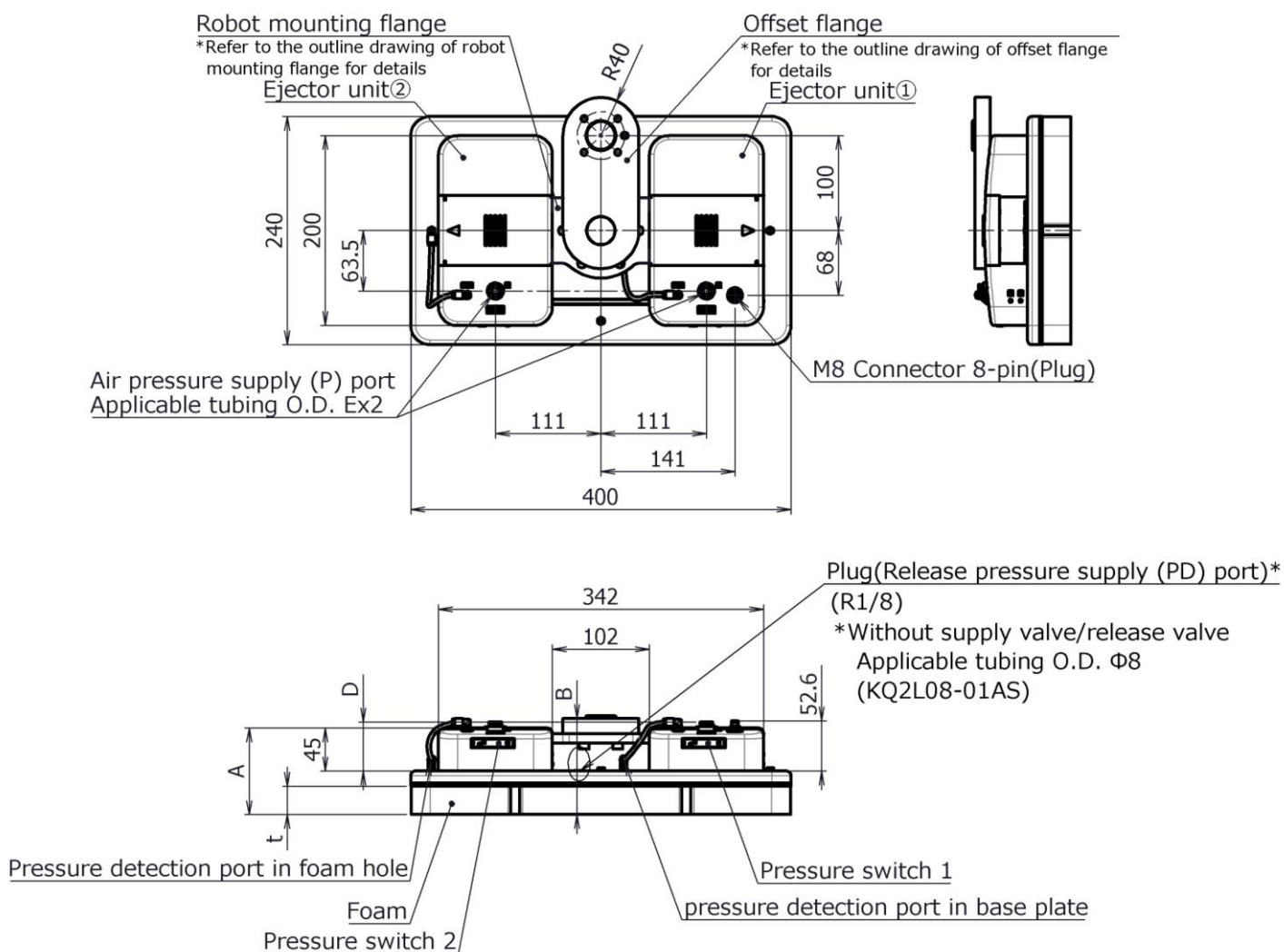

Table4-2. Dimensions

Order no.	t	A	B
ZGS021N*-400240A**-*2*	20	81	91
ZGS021N*-400240B**-*2*	30	91	101

Order no.	D	E
ZGS021N*-400240***-*C8	51.4	$\phi 8$
ZGS021N*-400240***-*C10	52	$\phi 10$
ZGS021N*-400240***-*N9	51.4	$\phi 5/16''$
ZGS021N*-400240***-*N11	51.9	$\phi 3/8''$

6.3. Vacuum Gripper System without robot mounting flange

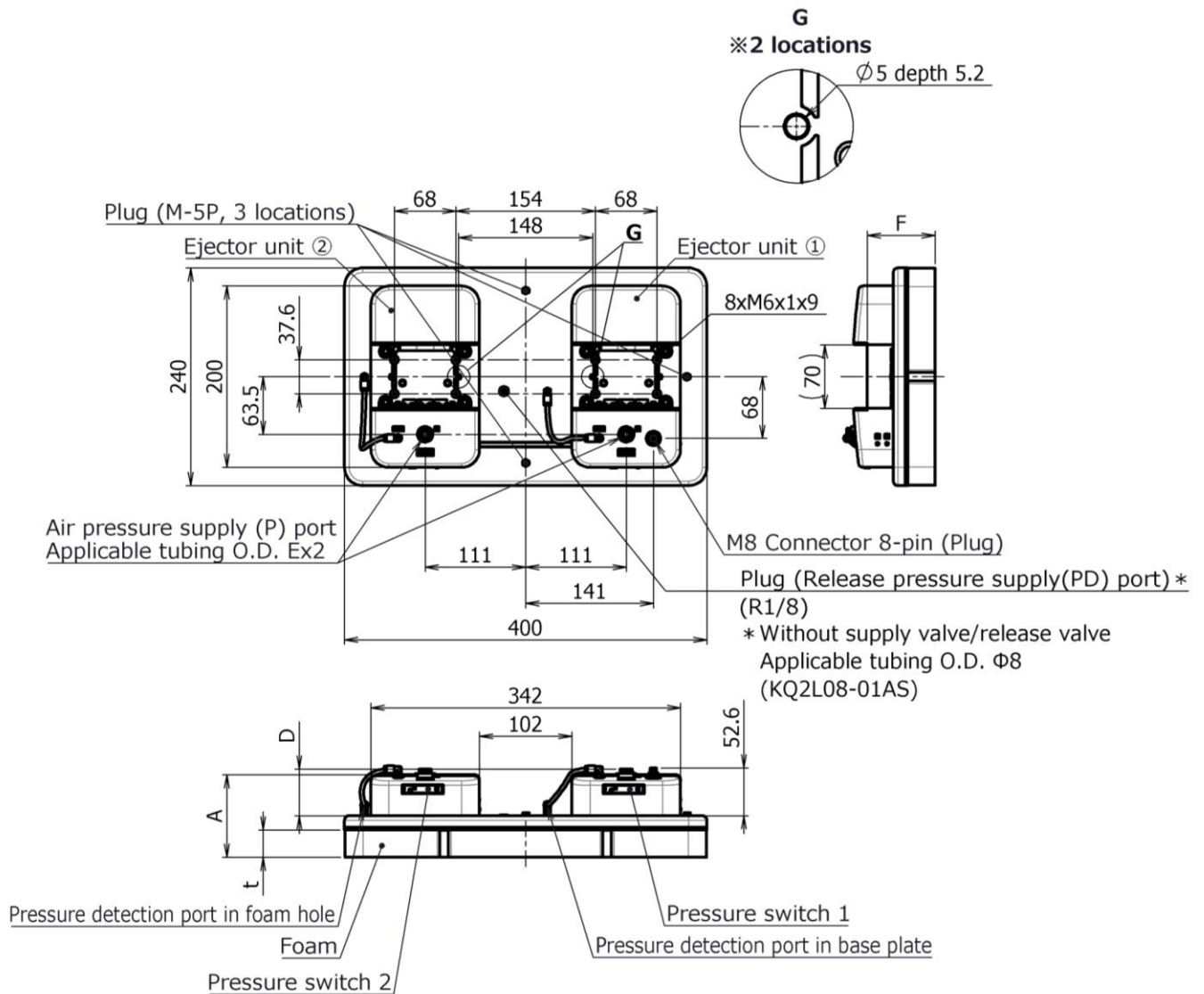
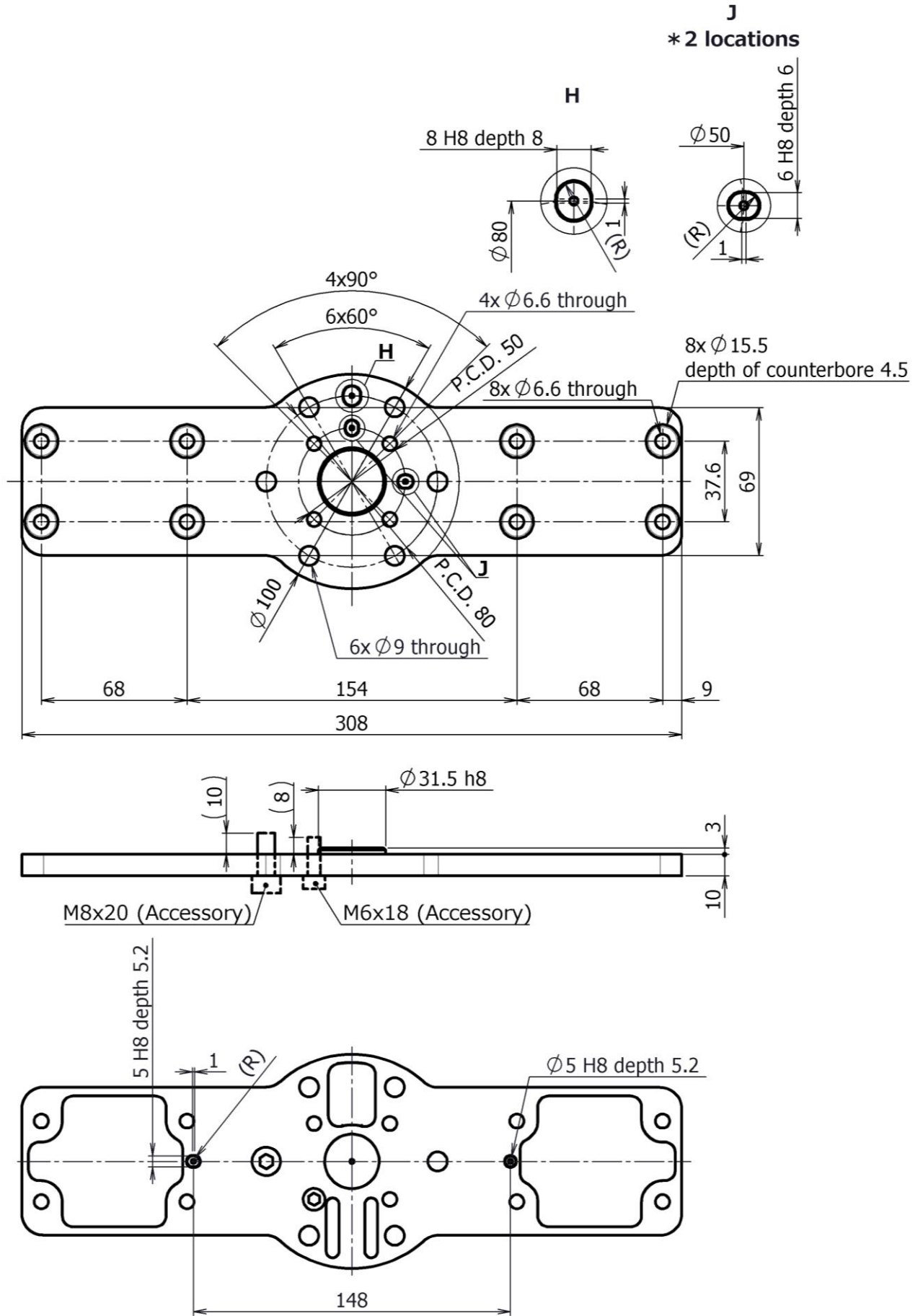

Table 5. Dimensions

Order no.	t	A	F
ZGS***-400240A***-***	20	81	65
ZGS***-400240B***-***	30	91	75

Order no.	D	E
ZGS***-400240***-***C8	51.4	φ8
ZGS***-400240***-***C10	52	φ10
ZGS***-400240***-***N9	51.4	φ5/16"
ZGS***-400240***-***N11	51.9	φ3/8"

6.4. Robot mounting flange



6.5. Offset flange

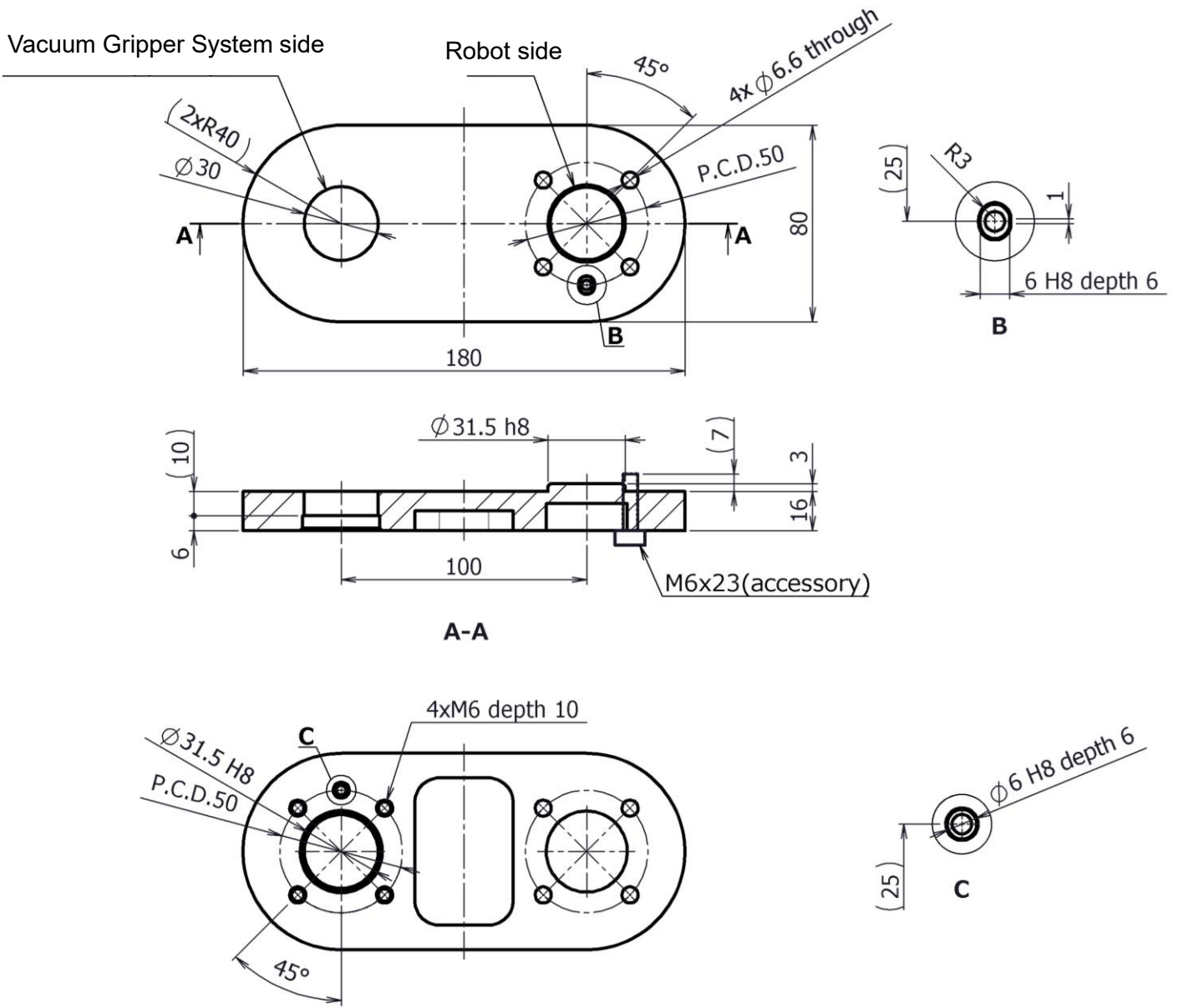

6.6. Tool center point and center of gravity and Weight

■ With robot mounting flange

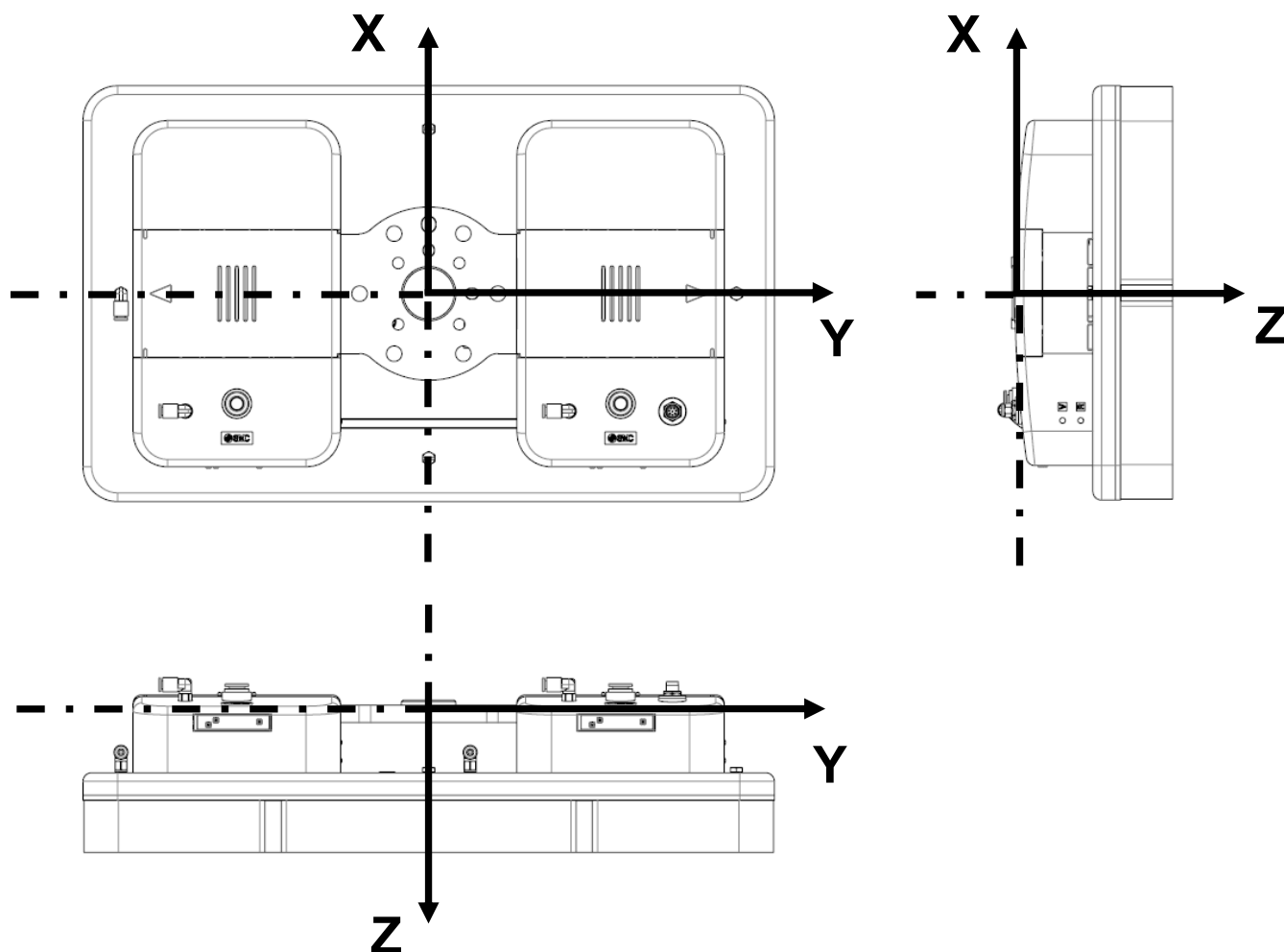

Table 6. T.C.P and C.O.G

In case of with flange for mounting the robot

(mm)

	ZGS***-400240 A **--**1*			ZGS***-400240 B **--**1*		
	Foam thickness 20mm			Foam thickness 30mm		
	X	Y	Z	X	Y	Z
Tool center point (T.C.P.)	0	0	75	0	0	85
Center of gravity (C.O.G.)	-1	3	31	-1	3	32

Table 7. weight

(kg)

	ZGS***-400240***--**1* With robot mounting flange	ZGS***-400240***--**_ * Without robot mounting flange
Weight	3.9	3.5

■ With robot offset flange

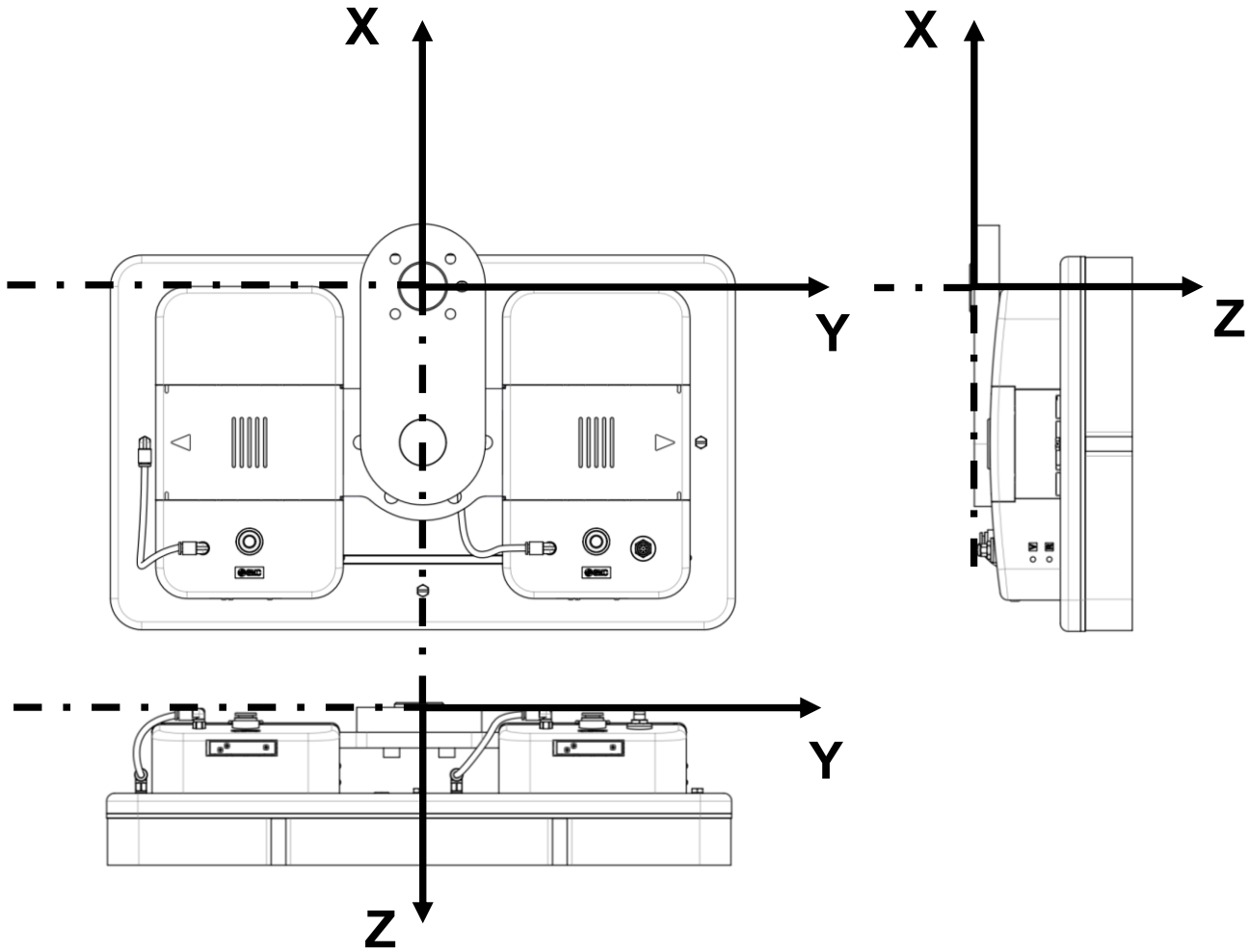

Table 6-a. T.C.P and C.O.G
In case of with offset flange

	(mm)					
	ZGS021N*—400240 A **—**2*			ZGS021N*—400240 B **—**2*		
	Foam thickness 20mm			Foam thickness 30mm		
	X	Y	Z	X	Y	Z
Tool center point (T.C.P.)	-100	0	91	-100	0	101
Center of gravity (C.O.G.)	-95	1	44	-95	1	45

Table 7-a. weight (kg)

	ZGS021N*—400240***—**2* With offset flange
Weight	4.4

7. Technical information

7.1. Theoretical lifting force for each suction area

Suction plate of vacuum saving valve type

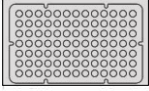
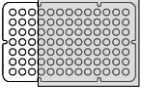
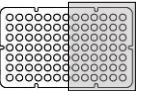
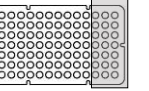
Number of ejectors assemblies[pcs]	Standard supply pressure [MPa]	Suction area [%]**3		100%	About 75%	About 50%	About 25%
		Number of suction holes [pcs]		91/91	70/91	42/91	21/91
2	0.58	Workpiece : Acrylic plate					
		Vacuum pressure [kPa]**1		-75.0	-59.4	-3.6	-1.9
		Theoretical lifting force[N]**2		2144	1306	48	13
		Lifting force considering safety factor[N]	Horizontal lifting (Safety factor:4)	536	326	11	3
Vertical lifting (Safety factor:8)	268		163	5	1		
4	0.6	Vacuum pressure [kPa]**1		-75.0	-70.9	-57.0	-6.1
		Theoretical lifting force[N]**2		2144	1559	752	40
		Lifting force considering safety factor[N]	Horizontal lifting (Safety factor:4)	536	389	188	10
			Vertical lifting (Safety factor:8)	268	194	94	5
6	0.6	Vacuum pressure [kPa]**1		-75.0	-71.9	-61.2	-56.8
		Theoretical lifting force[N]**2		2144	1581	808	375
		Lifting force considering safety factor[N]	Horizontal lifting (Safety factor:4)	536	395	201	93
			Vertical lifting (Safety factor:8)	268	197	100	46

*1 The vacuum pressure is the actual measured value when non-leakage workpiece (acrylic plate) is suctioned at the standard supply pressure. It is not guaranteed values.

*2 Theoretical lift force is a calculated value based on vacuum pressure and total foam hole area. It is necessary to judge the suitability for the workpiece with actual condition of use.

*3 Vacuum saving valve may not be activated when suction area is small.

(Recommended suction area: 2 ejectors, 75% or more, 4 ejectors: 50% or more, 6 ejectors: 25% or more)

Suction plate of fixed orifice type

Number of ejectors assemblies[pcs]	Standard supply pressure [MPa]	Suction area [%]		100%	About 75%	About 50%	About 25%
		Number of suction holes [pcs]		91/91	70/91	42/91	21/91
2	0.58	Vacuum pressure [kPa]**1		-75.0	-30.1	-11.1	-6.3
		Theoretical lifting force[N]**2		2144	662	146	42
		Lifting force considering safety factor[N]	Horizontal lifting (Safety factor:4)	536	165	36	10
			Vertical lifting (Safety factor:8)	268	82	18	5
4	0.6	Vacuum pressure [kPa]**1		-75.0	-48.9	-27.6	-19.7
		Theoretical lifting force[N]**2		2144	1075	364	130
		Lifting force considering safety factor[N]	Horizontal lifting (Safety factor:4)	536	268	91	32
			Vertical lifting (Safety factor:8)	268	134	45	16
6	0.6	Vacuum pressure [kPa]**1		-75.0	-55.8	-33.6	-26.6
		Theoretical lifting force[N]**2		2144	1227	443	175
		Lifting force considering safety factor[N]	Horizontal lifting (Safety factor:4)	536	306	110	43
			Vertical lifting (Safety factor:8)	268	153	55	21

*1 The vacuum pressure is the actual measured value when non-leakage workpiece (acrylic plate) is suctioned at the standard supply pressure. It is not guaranteed values.

*2 Theoretical lift force is a calculated value based on vacuum pressure and total foam hole area. It is necessary to judge the suitability for the workpiece with actual condition of use.

7.2. How to use the pressure switch to confirm gripping

The built-in pressure switch detects pressure of the following two locations.

At the time of shipment from the factory

1. Pressure in a foam hole
2. Pressure in Base plate

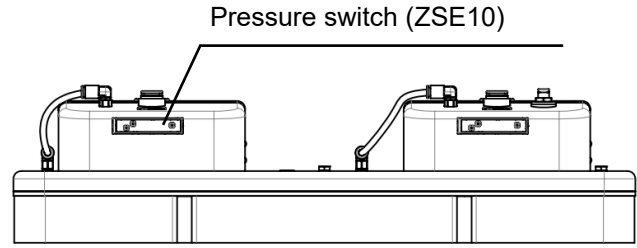

By changing the piping connection points, pressure detection port can be changed at any to points.

- Pressure in Base plate(1 point) + Pressure in a foam hole (1 point)
- or
- Pressure in two foam holes

⚠ If the pressure detection port in Base plate is not used, the port needs to plug. If not plugged, air leakage will occur, and the vacuum pressure cannot generate when gripping.

4 selectable ports to detect vacuum pressure in a foam hole.

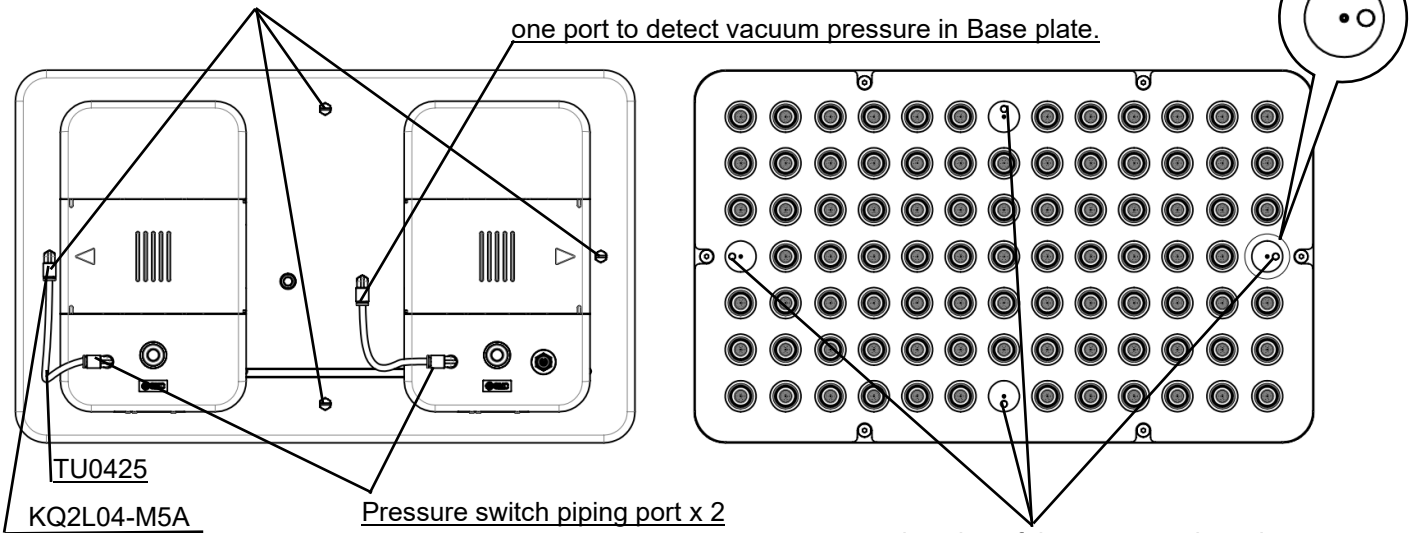

(Refer to No.20 on P.32)

location of the pressure detection port in of a foam hole(4 locations)
(Vacuum saving valve is not installed.)

< Usage example of the pressure detection port in a foam hole >

Pressure in a foam hole:0kPa

Pressure in Base plate:-50kPa

When detecting the pressure in a foam hole directly, workpiece drop can be detected.

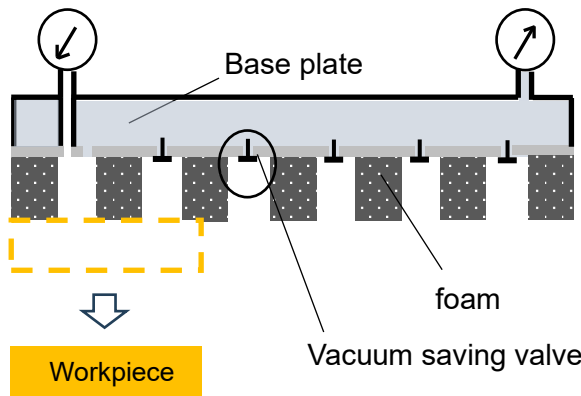

When workpiece drop occurs, the vacuum saving valves are closed and the vacuum pressure in Base plate increases. It may not detect the workpiece drop with pressure in Base plate.

7.3. Supply valve and release valve LED lamp indication

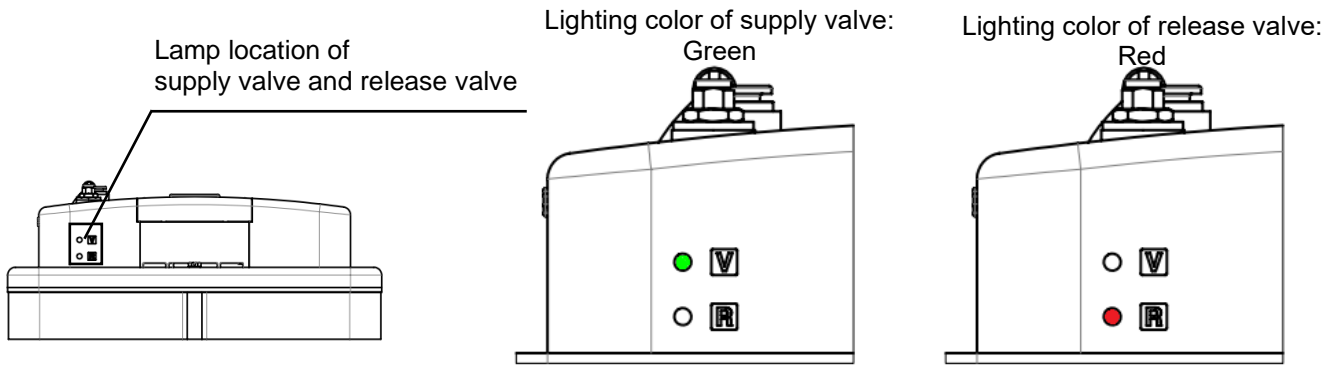

	Lamp indication	N.C.	N.O.
		Applicable product number ZGS**K-400240***-****	Applicable product number ZGS**B-400240**-****
Supply valve	Lit up(Green)	Suction ON	Suction OFF
	Off	Suction OFF	Suction ON

	Lamp indication	N.C.
		Release valve
	Off	Blow-off OFF

8. Maintenance

- Perform the maintenance and inspection shown below in order to use the electric vacuum gripper in a safe and appropriate manner for a long time.

8.1. Maintenance for Vacuum Gripper System

Caution

1) Inspection before and after maintenance

When removing the product from the equipment, ensure that the power supply is turned off and the vacuum pressure inside the product is released. When returning the product to the equipment after maintenance, connect to the power.

2) Inspect the vacuum gripper system regularly.

- Regularly inspect the vacuum gripper system to ensure that there are no cracks or wear in the foam. Replace the foam as necessary.
- Regularly inspect the mesh fitted to the foam or vacuum saving valve, the silencer element to ensure that they are not clogged. Clean or replace them as necessary. To check for clogging, use the pressure detection port in the base plate and measure the pressure during suction without a workpiece to grip. An increase in vacuum pressure without a workpiece indicates clogging. A decrease in vacuum pressure without a workpiece indicates air leakage.

3) Regularly tighten connections which may be loosened by the use for a long period.

The part connections may be loosened by vibration or impact when the gripper system is operated for a long time. Tighten the connections regularly to ensure that parts do not fall off and the gripper system is properly installed on the equipment.

4) Do not disassemble or modify the product, other than replacement of the parts specified in this manual.

8.2. How to replace parts

8.2.1 Parts name and parts number

Foam and Vacuum saving valve

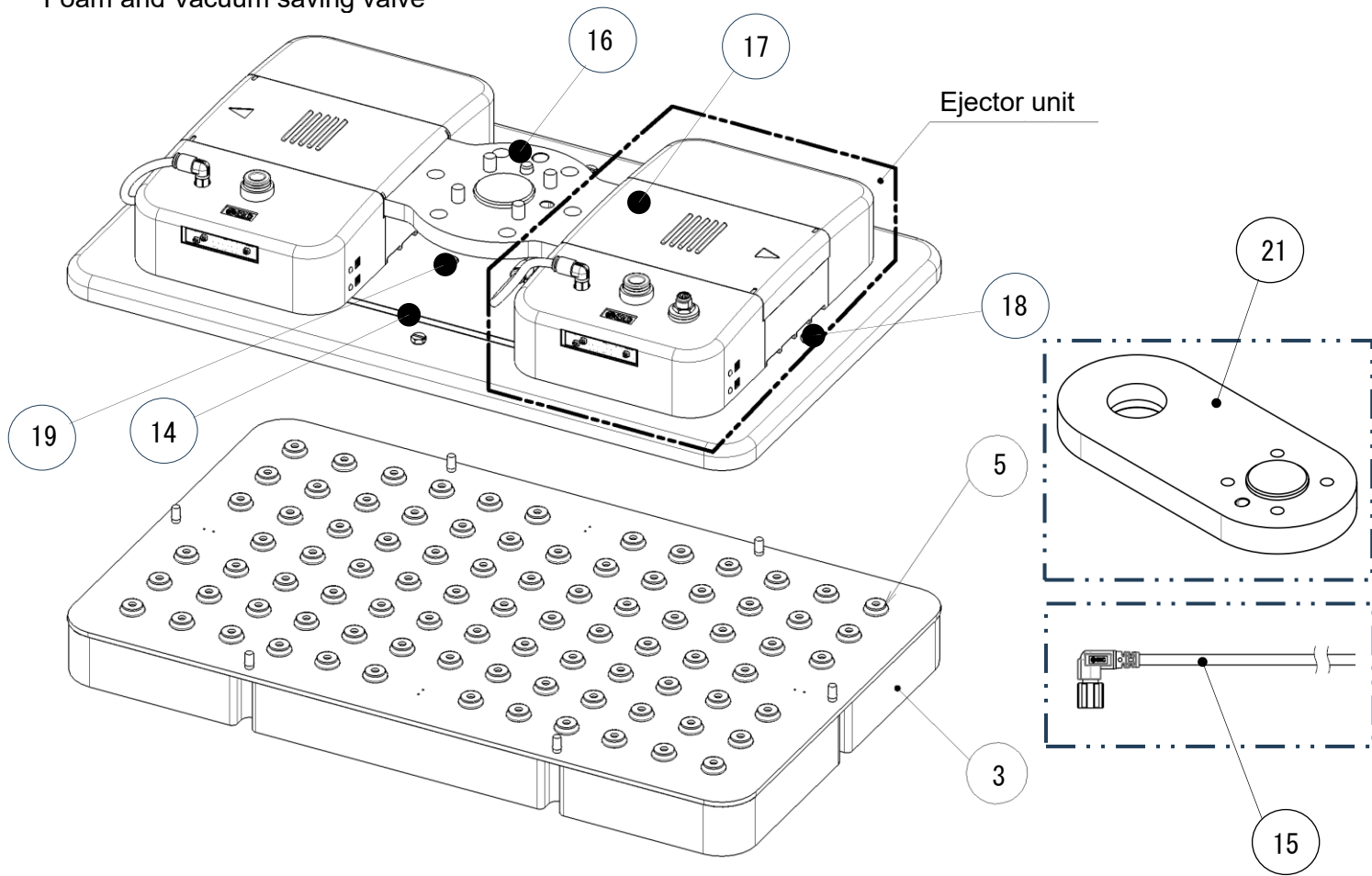

Ejector unit

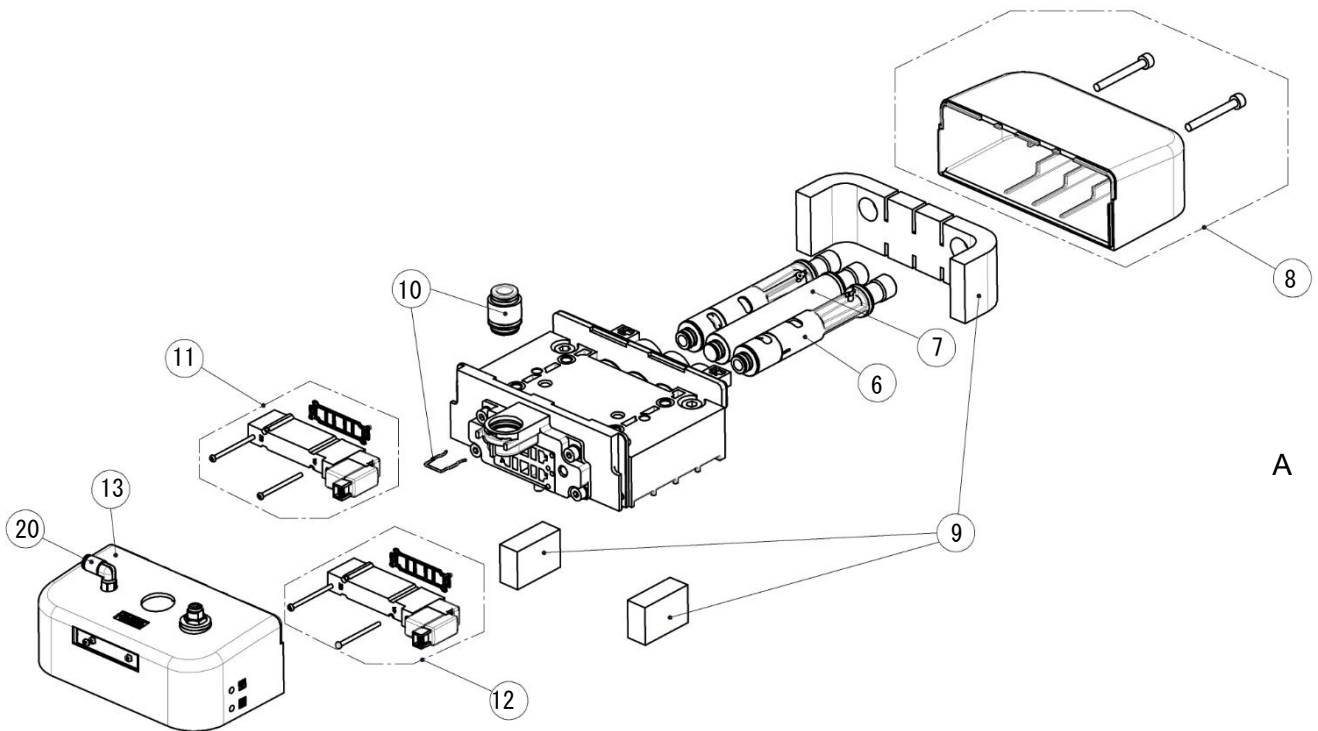

Table8. Spare part numbers

No	Description	Part No	Replacement procedure	Remarks
1	Foam with plate (For vacuum saving valve type)	ZGS-FM1-400240T20P-A		Refer to table9
		ZGS-FM1-400240T30P-A		
2	Foam with plate (For fixed orifice type)	ZGS-FM1-400240T20MP-A		
		ZGS-FM1-400240T30MP-A		
3	Foam (For vacuum saving valve type)	ZGS-FM1-400240T20-A		foam's thickness 20mm
		ZGS-FM1-400240T30-A		foam's thickness 30mm
4	Foam with mesh (For fixed orifice type)	ZGS-FM1-400240T20M-A		foam's thickness 20mm
		ZGS-FM1-400240T30M-A		foam's thickness 30mm
5	Vacuum saving valve	ZGS-BD2-A		Included stopper
6	Ejector assembly	ZGS-EJ1-V-A	Procedure.1→2→3→5	
7	Dummy ejector assembly	ZGS-EJ1-D-A	Procedure.1→2→3→5	
8	Ejector cover set	ZGS-LD2-A	Procedure.1→2→3→4	With mounting screws
9	Sound absorbing material set	ZGS-SE1-A	Procedure.1→2→3→4 Procedure.1→2→6→7	
10	One-touch fitting set	ZGS-PR1-* -A	Procedure.1→2→6→8→9	With clip Refer to below for part No. (For air pressure supply (P) port)
11	Supply valve set	ZGS-JSY3V-A	Procedure.1→2→6→8→9	With Gasket and mounting screws
12	Release valve set	ZGS-JSY3R-A	Procedure.1→2→6→8→9	With Gasket and mounting screws
13	Valve cover assembly	ZGS-LD1-***-A	Procedure.1→2→6→8	Refer to below for part No.
14	Connector cable assembly	ZGS-LW1-8-A		PNP type
		ZGS-LW1-6-A		NPN type
15	Connector cable	RMH-A00-11-A		
		RMH-A00-11-B		
		RMH-A00-18A		
		ZGS-LW1-14-A		
16	Robot mounting flange	ZGS-PL3-1-A		Refer to parts included in the package
17	Flange cover	ZGS-LD3-A	Procedure.1	Quantity:1
18	Plug	M-5P		
19	Plug	TB00070		
20	One-touch fitting	KQ2L04-M5A		(For pressure detection port) Refer to 7.2 of P.29
21	Offset flange	ZGS-PL5-1-A		Refer to parts included in the package

10 One-touch fittings set
ZGS-PR1- * -A



13 Valve cover assembly
ZGS-LD1- * * * -A

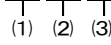

(1) Air pressure supply (P) port

Symbol	Air pressure supply (P) port
C8	φ8
C10	φ10
N9	φ5/16"
N11	φ3/8"

(1)	(2)	Compatible Robot
Cover shape	Robot Specifications	
Symbol	Symbol	
1 (With M8 connector)	P	NP,011P,012P,043P,052P
	N	NN,043N
	T	021N
2 (Without M8 connector)	P	NP,011P,012P,043P,052P
	N	NN,043N,021N

(3)

Pressure switch unit specifications

Symbol	Content
C	With unit switching function
M	Fixed SI unit

Table.9 part number and applicable product number

Maintenance part		For vacuum saving valve type	For fixed orifice type
Type	Thickness [mm]		
Form with plate	20	ZGS-FM1-400240T20P-A	ZGS-FM1-400240T20MP-A
	30	ZGS-FM1-400240T30P-A	ZGS-FM1-400240T30MP-A
Form	20	ZGS-FM1-400240T20-A	ZGS-FM1-400240T20M-A
	30	ZGS-FM1-400240T30-A	ZGS-FM1-400240T30M-A
(Applicable product number)		ZGS***-400240* S *-****	ZGS***-400240* M *-****

8.2.2 How to replace foam with plate

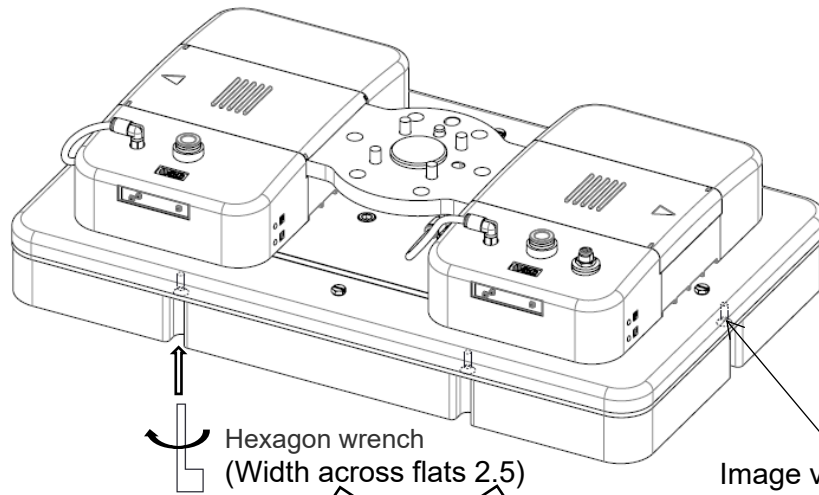

Foam with plate
(For vacuum saving valve type)

Foam with plate
(For fixed orifice type)

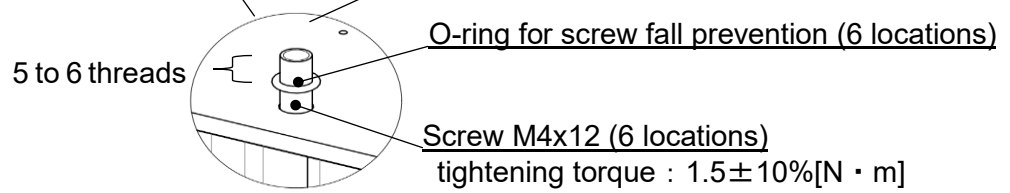
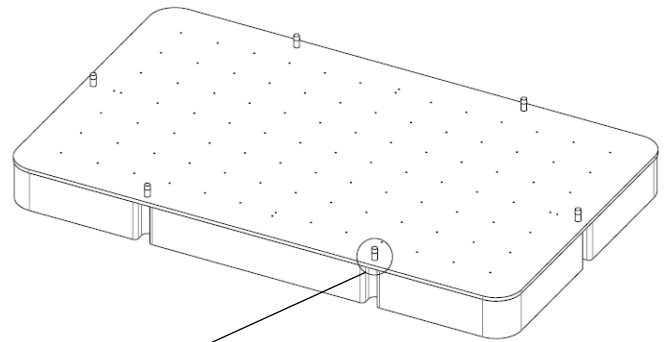
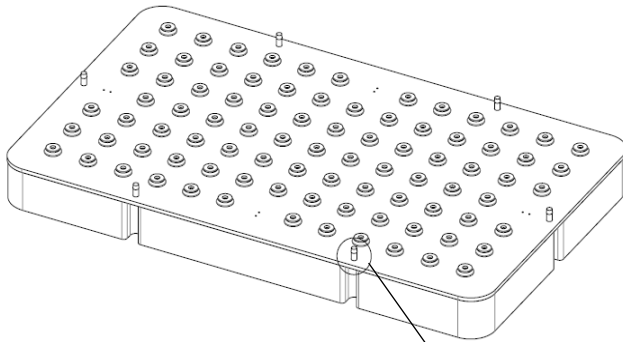

8.2.3 How to replace foam

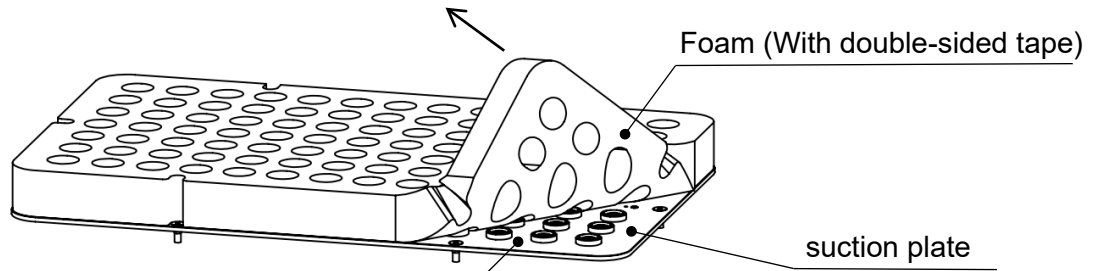

Clean suction plate surface for foam side with IPA (Isopropyl alcohol).

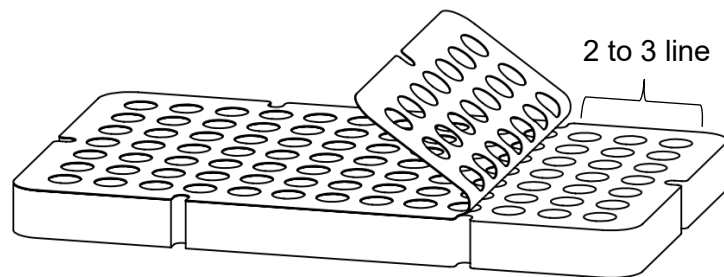
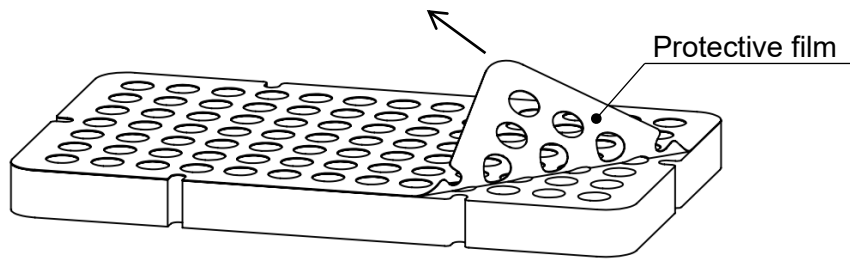

Mount foam to suction plate countersink side

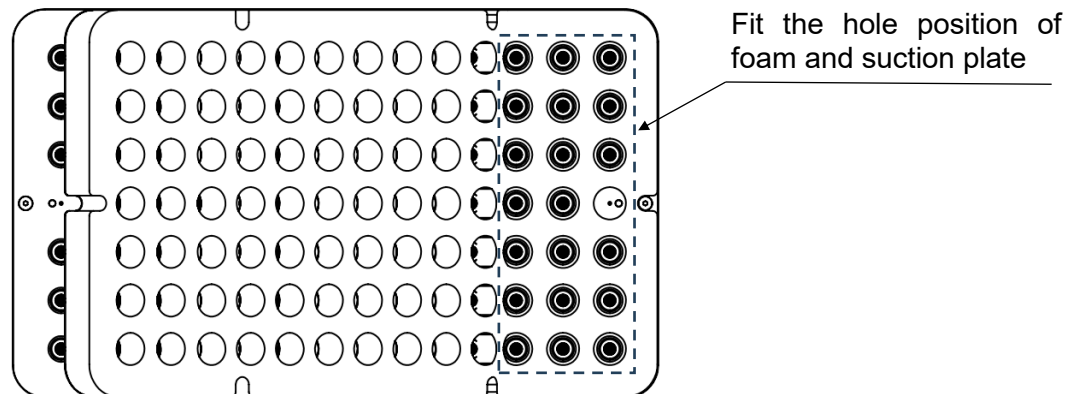
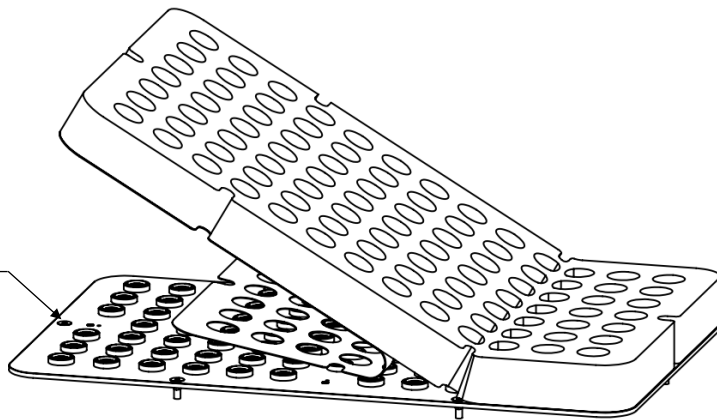

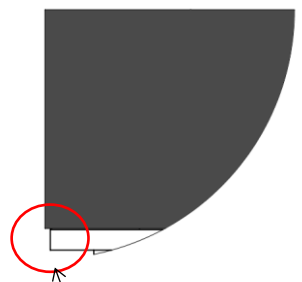
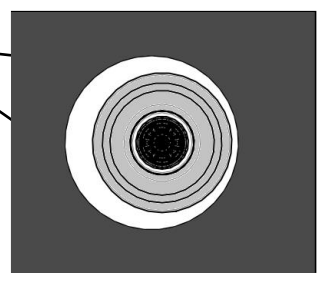
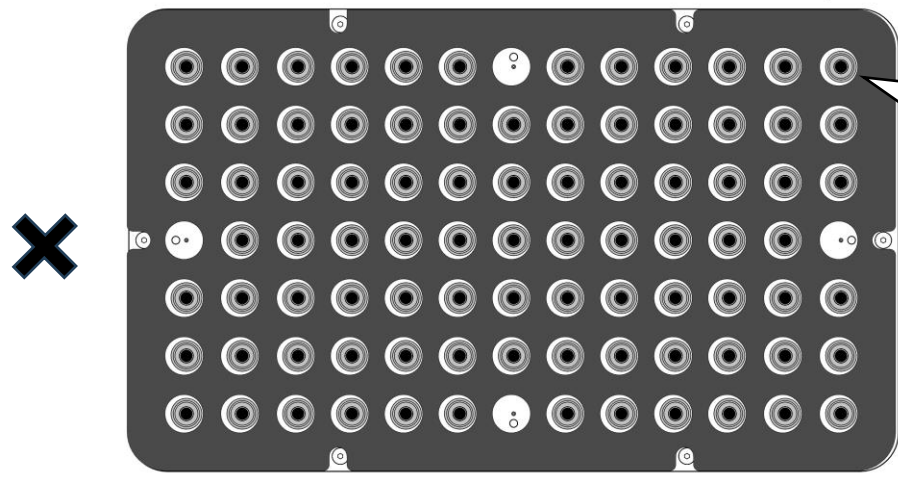
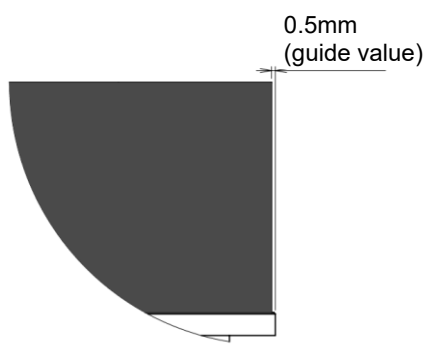
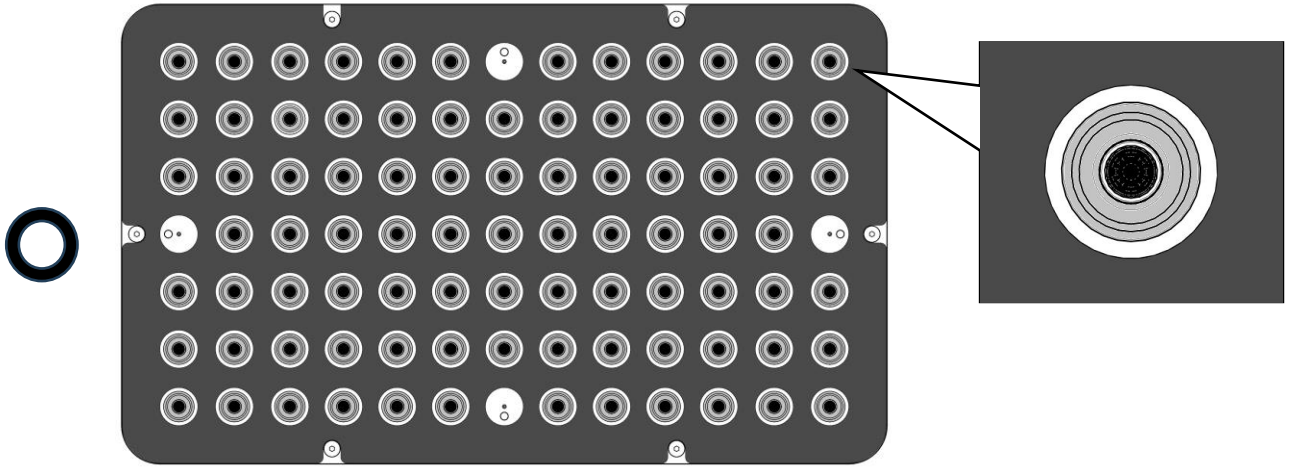

Protruding foam from suction plate

8.2.4 How to replace Vacuum saving valves

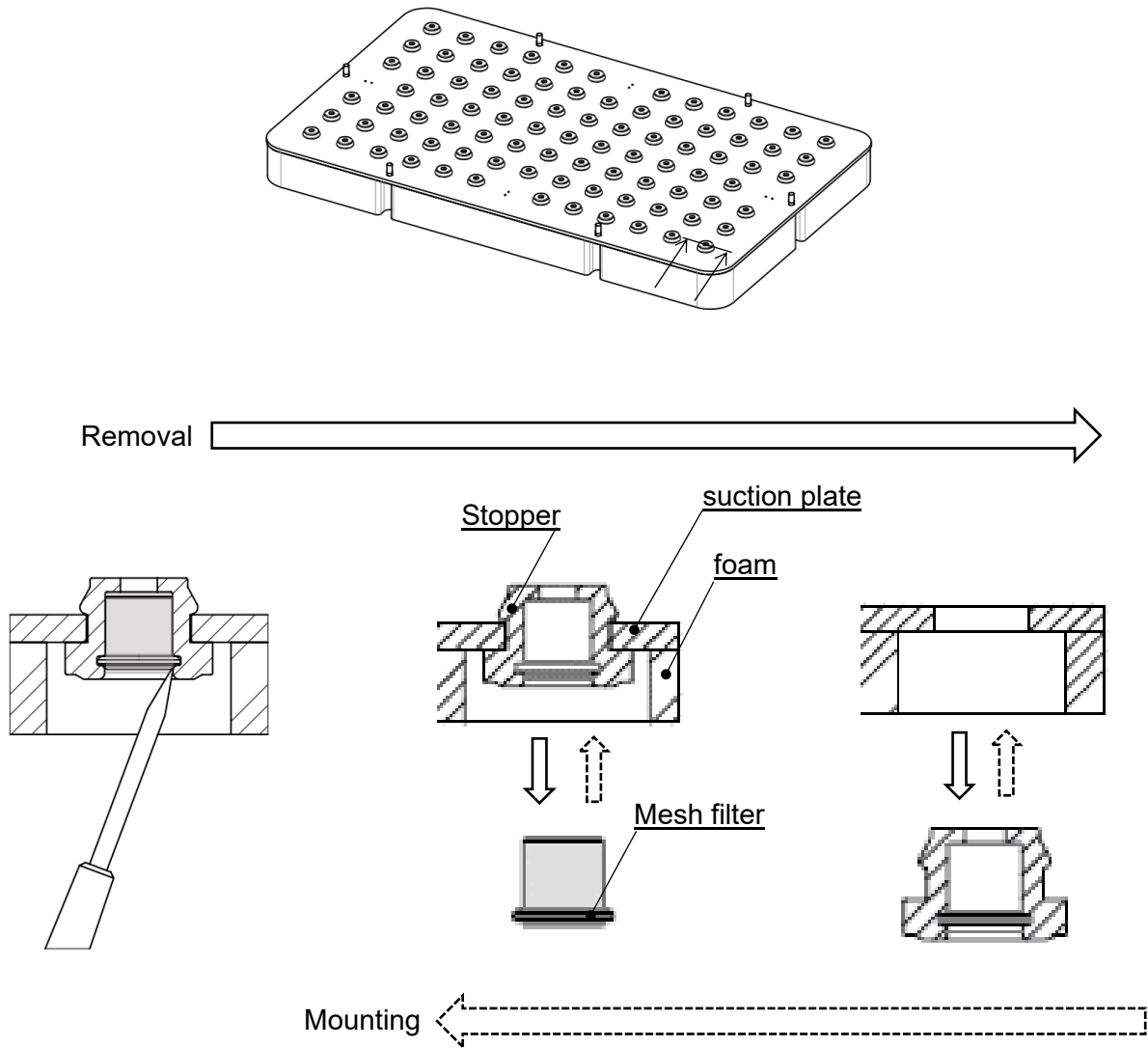

* If inserting of vacuum saving valve is hard,
greasing fluorine grease to inside of stopper thinly.

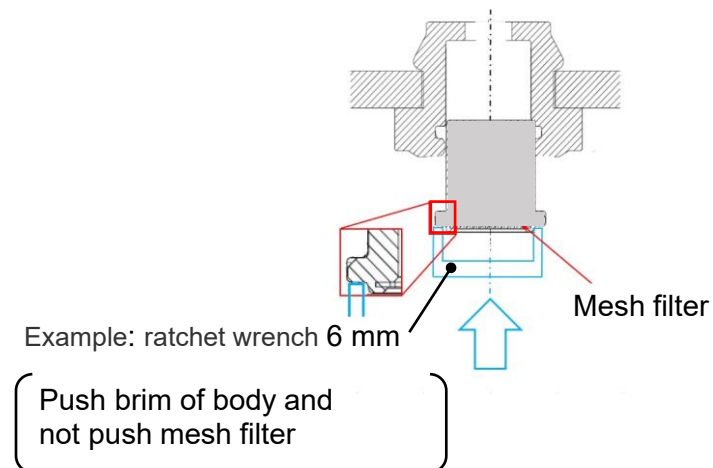

8.2.5 How to replace Ejector unit

(Refer to replacement procedure of Table 8. Spare part numbers)

Procedure 1

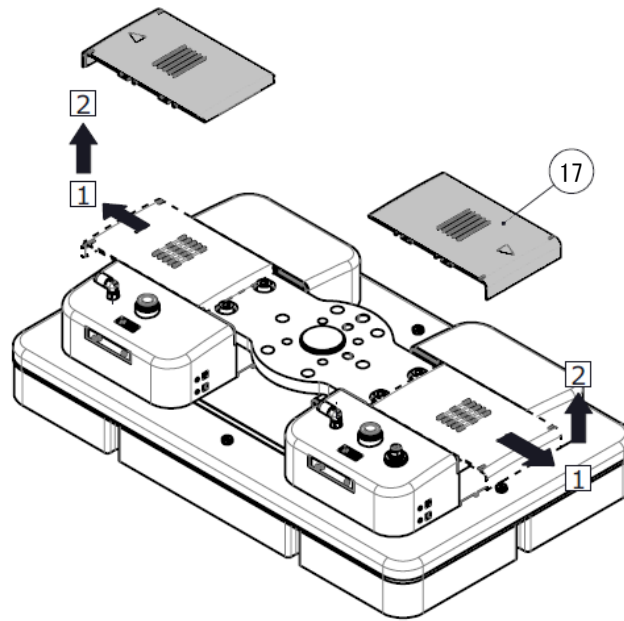

Procedure 2

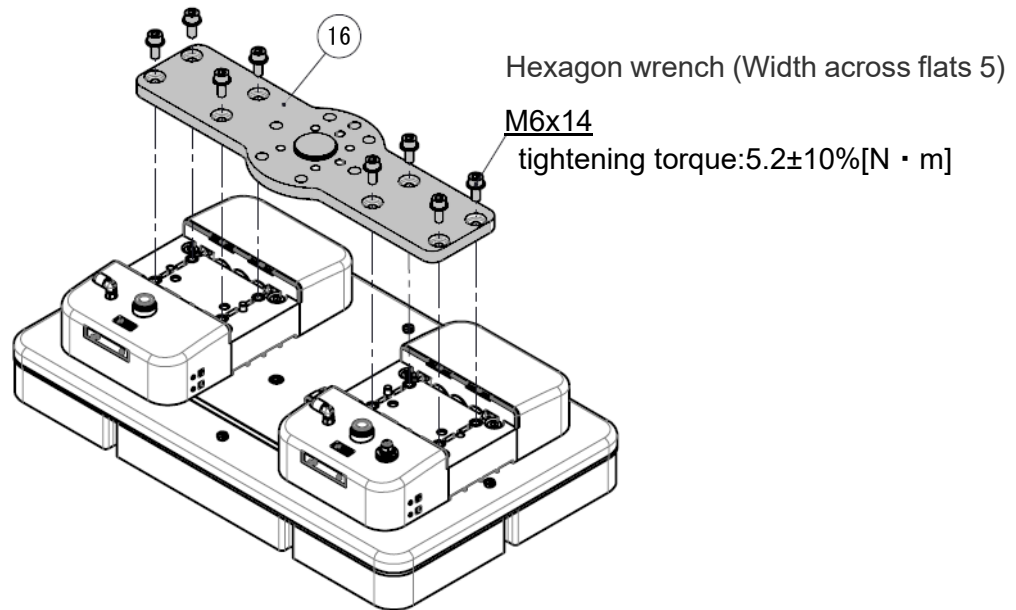

Procedure 3

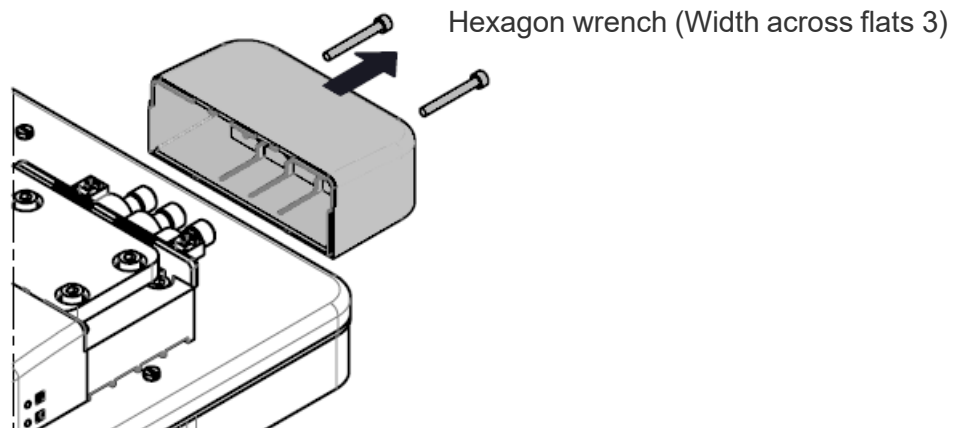

Procedure 4

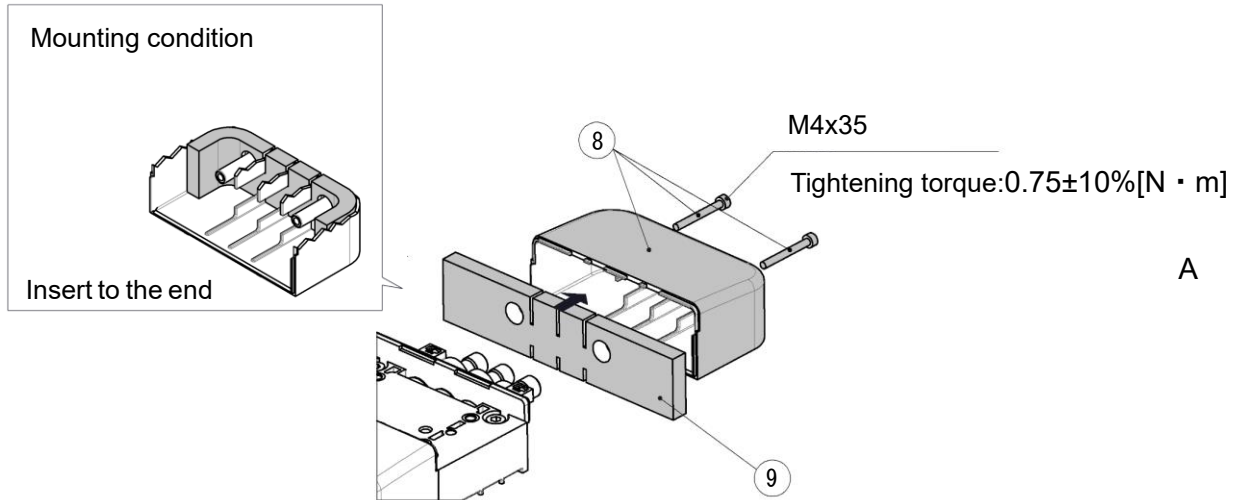

Procedure 5

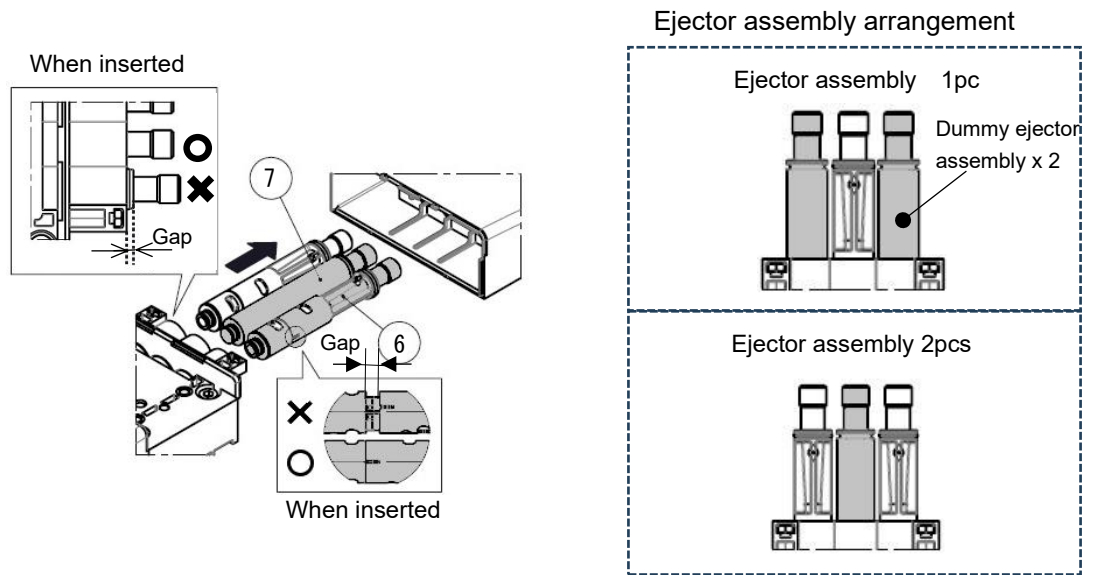

Procedure 6

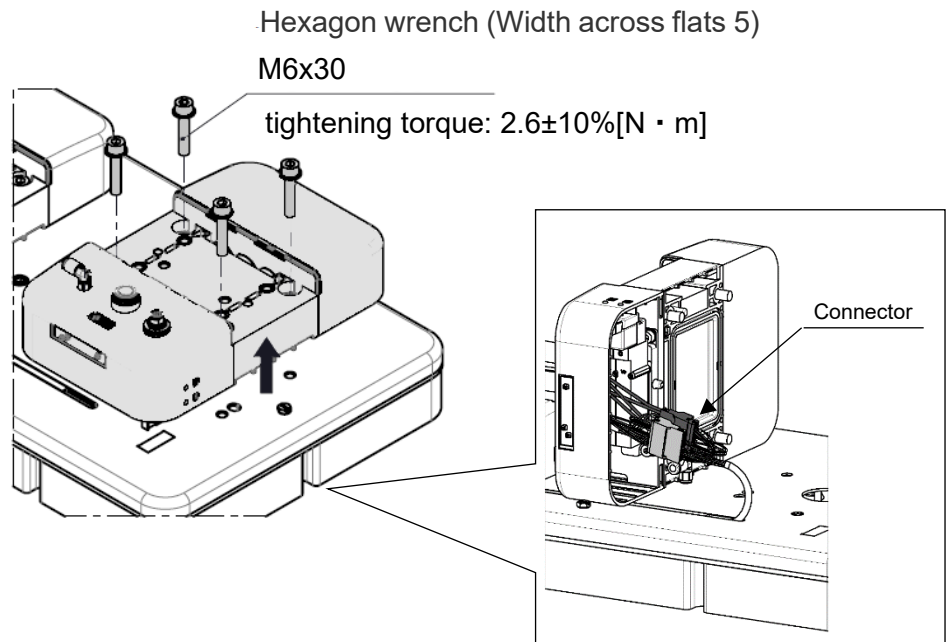

Procedure 7

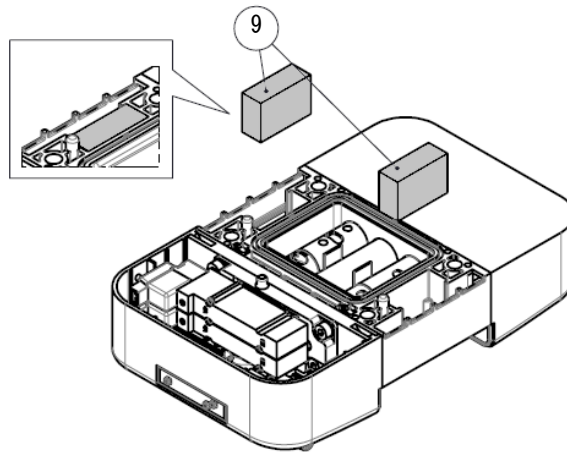

Procedure 8

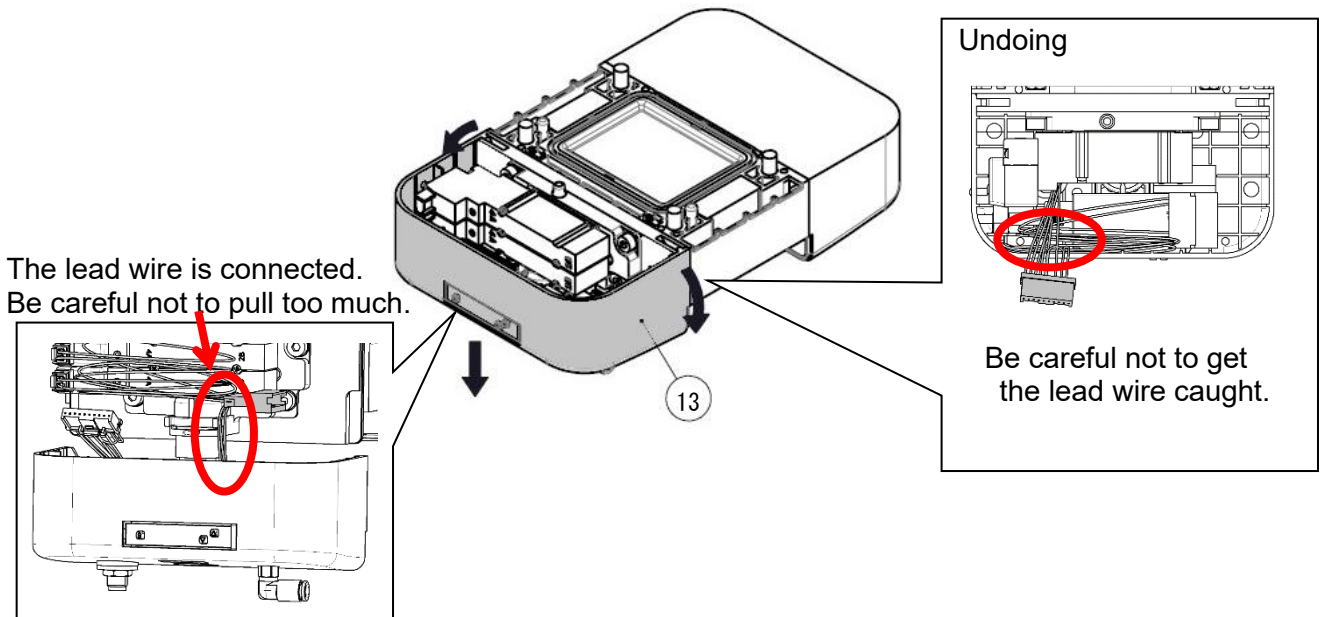

Procedure 9

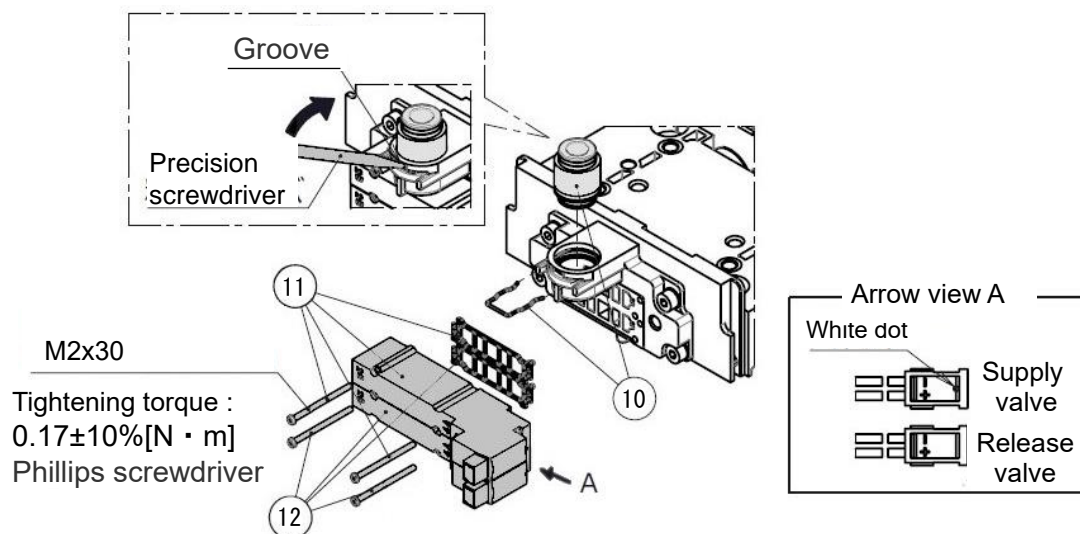

8.2.6 How to replace Connector cable assembly

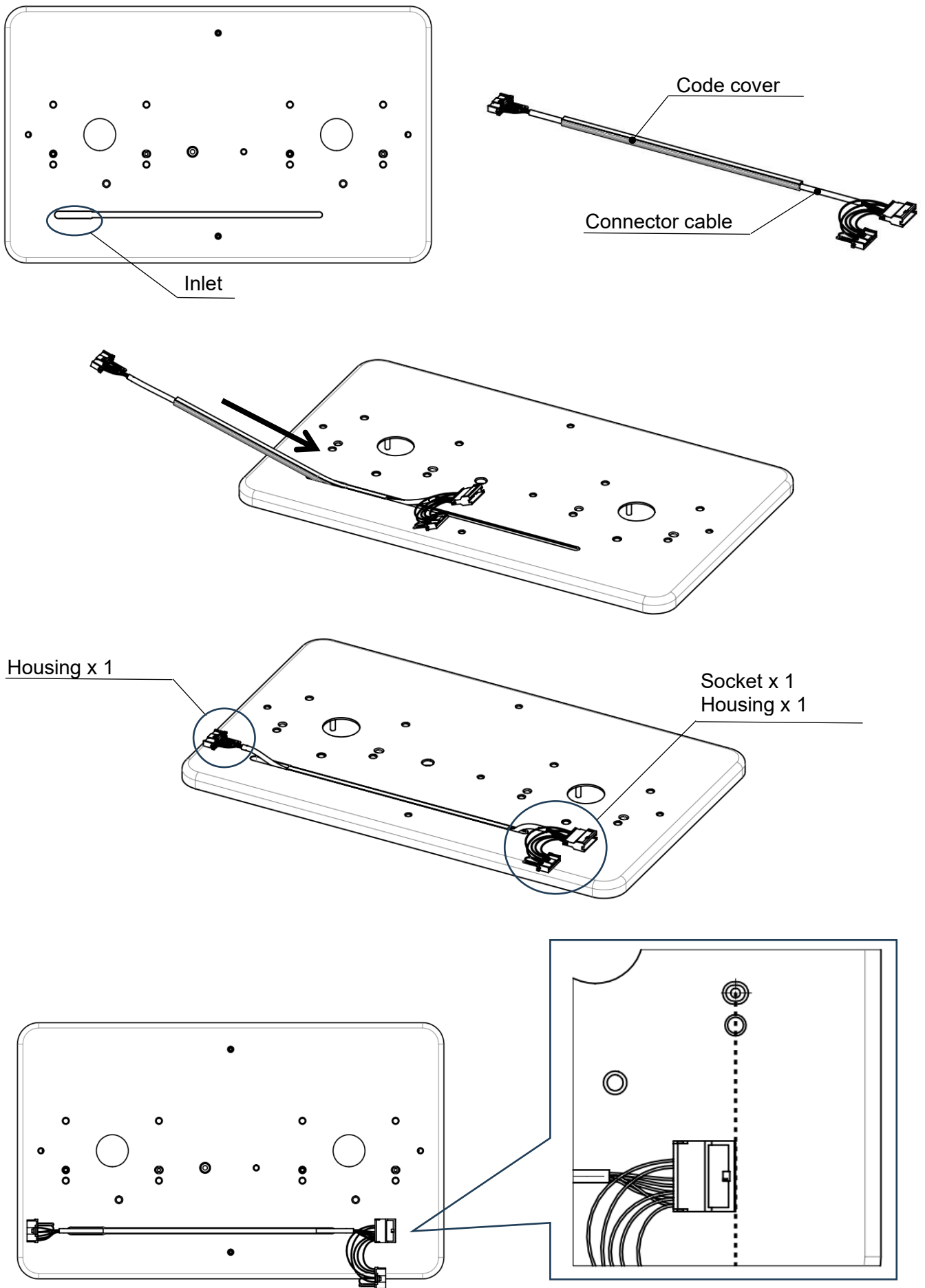

9. Precautions

Warning

Do not put a finger between the foam and the workpiece; it can be caught during suction.

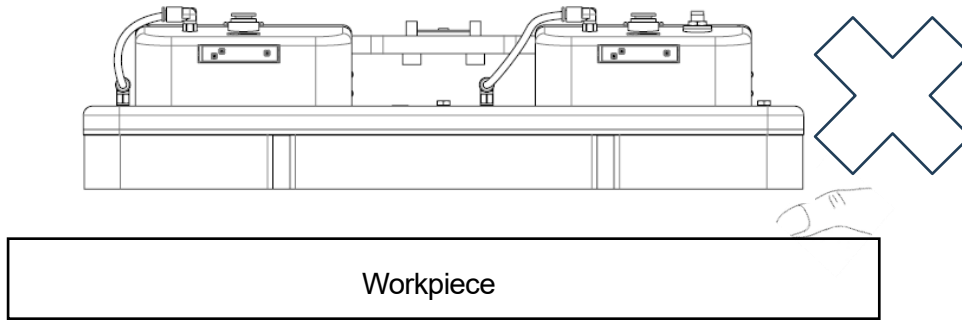

Caution

1) Test the product before use by installing it on the equipment and operating it in your operating environment or conditions to ensure that it meets required functionality, taking into account the following:

- The foam's thickness and airtightness vary due to production reasons.
- Porous workpieces such as cardboard cause more air leakage than other workpieces, resulting in a reduction in lifting force.

In addition, take safety measures before use to prevent accidents, such as workpieces being dropped during transport.

- 2) Design the equipment with safety in mind, taking into account a vacuum pressure drop caused by a power or air supply failure. Provide preventive measures against the fall of workpieces where this may cause danger.
- 3) Use this product within its specifications.
If it is used outside the specifications, its performance will be decreased, resulting in serious damage or injury.
- 4) Do not block the opening of the product and restrict air exhaust from it.

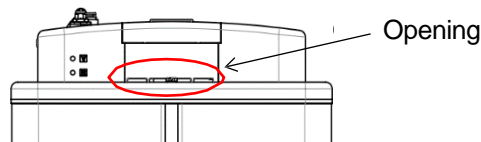

- 5) Before suction, press the foam onto the workpiece so that the foam adapts to the unevenness of the workpiece surface. It is recommended that the foam is compressed to approximately 50% of its original thickness.
- 6) Do not pressurize the product with the ejector cover removed; ejector assembly may jump out.
- 7) Premature clogging may occur if the product is used in a dusty environment or with dusty workpieces. Service the product regularly, including replacement of the foam.
- 8) The presence of oil or water on the product or workpiece can adversely affect the product, causing a decrease in performance.

■ Storage

Warning

- 1) Do not store the product in a place where it is exposed to rain, water, harmful gases or liquids.
- 2) Store the product out of direct sunlight and within the product's operating temperature range.
- 3) Do not apply vibration or impact to the product during storage.

10. Troubleshooting

When any failure occurs to the product, perform the following trouble shooting.

Failure phenomenon		Possible causes		Countermeasure No.
Vacuum absorption failure	Vacuum is not generated	Supply valve does not operate	Decline in the power supply voltage	1)
			Electrical wire failure	2)
			The supply pressure exceeds the operating pressure range.	3)
	Vacuum pressure decreased		Clogging by foreign matter or particles	4),5)
			Clogging of the filter	5)
			Clogging of the sound absorbing material.	4), 5)
			Deterioration of the adsorbing part and air leakage due to wearing.	6)
			Incorrect assembly during maintenance (incorrect mounting of the gasket or O-ring)	7)
			Insufficient supply pressure	8)
			Supply valve and release valve operate simultaneously	9)
Sealing failure due to the deterioration of the check valve	10)			
Fluctuation of vacuum pressure	Noise is generated intermittently when air is exhausted when absorbing by vacuum and vacuum pressure slightly fluctuates.	Vibration of fluid when vacuum pressure is generated	11)	
Vacuum release failure	Release air is not output	Release valve does not operate,	Decline in the power supply voltage	1)
			Electrical wire failure	2)
			The supply pressure exceeds the operating pressure range.	3)
	Workpiece is not released smoothly.		Decrease of release flow	12)
			Interlocking of supply valve and release valve	9)

No	Countermeasure
1)	Adjust the rated voltage so that the supply voltage for the solenoid valve is within +/-10% of the rated voltage while the simultaneously energized equipment is ON.± When the vacuum pressure switch is wired to the common power supply, the rated voltage shall be maintained while the switch is energized.
2)	Check the correct connection of the power supply and wiring of plug connectors.
3)	If the supply pressure is lower than the operating pressure range, it may cause operation failure of the solenoid valve. If the supply pressure is higher than the operating pressure range, it may cause operation failure because of early defect due to wear of seals. Adjust the supply pressure appropriate. Ejectors consume a large amount of air during operation. Ensure that the supply pressure is within the operating range.
4)	Oil mist in the supply air or particles in the piping cause clogging if they enter into the ejector. This may cause operation failure. Blow the air piping with air to eliminate particles. It is recommended installing the mist separator and air filter for cleaner supply air. Perform regular maintenance for mist separator and filter. Refer to the product catalogue or operation manual for details of the maintenance.
5)	Substances adhere to the surface of the workpiece may enter into the ejector, causing clogging. Perform regular maintenance for the foam with mesh, vacuum saving valve.
6)	Replace the foam or foam with plate. Revise the absorbing condition based on the relation between the vacuum pressure and workpiece.
7)	If the gasket or O-ring come out or get caught during maintenance, leakage of vacuum or air occurs from there. In this case, disassemble the parts and reassemble the gasket and O-ring correctly.
8)	If the supply pressure during the operation of the ejector decreases, the generated vacuum pressure decrease. Apply adequate flow rate so that the supply pressure is adequate when other air equipment operate simultaneously.
9)	Vacuum pressure and release flow decrease if the supply valve and release valve are operated simultaneously. Check the control program and wiring.
10)	In the following cases, the vacuum pressure does not increase adequately. (1) The check valve in the ejector assembly is deteriorated by long-term use. (2) Dirt adhered to the sealing surface. Replace the ejector assembly.
11)	When the ejector vacuums the workpiece, high speed air coming out of the nozzle collides into the diffuser I.D. and bounces back, generating vibration in the exhaust air. Because of this, the vacuum pressure fluctuates slightly and is not stabilized. There should be no functional problem with the ejector. The phenomenon causes noise or could be a problem for the setting of vacuum switch. The noise can be eliminated by changing the supply pressure. Adjust the pressure regulating valve for supply pressure while checking the exhaust noise and vacuum pressure until the noise disappear. Ejector may generate noise due to the increase of exhaust resistance. When the silencer becomes dirty, the replacement of the silencer element may improve the condition.
12)	If clogging occurs in the mesh fitted to the foam, and the mesh filter of the vacuum saving valve, resulting in release air decrease. Regular maintenance is necessary.

Revision history

Rev.A: Replaced diagram due to change in sound absorbing material [July 2024]
Rev B: Dealing with OMRON TECHMAN ROBOT [August 2024]
Rev C: Page 32 Added valve cover assembly part number [September 2024]

SMC Corporation

Tel: + 81 3 5207 8249 Fax: +81 3 5298 5362
URL <https://www.smcworld.com>

Note: Specifications are subject to change without prior notice and any obligation on the part of the manufacturer.
© SMC Corporation All Rights Reserved