



Operation Manual

PRODUCT NAME

High Vacuum Angle Valve / Straight Valve

MODEL / Series / Product Number

XMA/XYA Series

SMC Corporation

Contents

Safety Instructions	-----	2
1. Product Specific Precautions 1 (Precautions on Design, Selection, Mounting, Piping, Maintenance)	-----	4
2. Product Specific Precautions 2 (Maintenance parts)	-----	6
3. Specifications	-----	7
4. Construction / Dimensions	-----	8
5. Period and Scope of Warranty	-----	10
6. Parts Replacement Procedure	-----	11



Safety Instructions

These safety instructions are intended to prevent hazardous situations and/or equipment damage. These instructions indicate the level of potential hazard with the labels of “**Caution**,” “**Warning**” or “**Danger**.” They are all important notes for safety and must be followed in addition to International Standards (ISO/IEC)^{*1)}, and other safety regulations.

*1) ISO 4414: Pneumatic fluid power - General rules and safety requirements for systems and their components
ISO 4413: Hydraulic fluid power - General rules and safety requirements for systems and their components
IEC 60204-1: Safety of machinery - Electrical equipment of machines - Part 1: General requirements
ISO 10218-1: Robots and robotic devices - Safety requirements for industrial robots - Part 1: Robots
etc.



Danger

Danger indicates a hazard with a high level of risk which, if not avoided, will result in death or serious injury.



Warning

Warning indicates a hazard with a medium level of risk which, if not avoided, could result in death or serious injury.



Caution

Caution indicates a hazard with a low level of risk which, if not avoided, could result in minor or moderate injury.

Warning

1. The compatibility of the product is the responsibility of the person who designs the equipment or decides its specifications.

Since the product specified here is used under various operating conditions, its compatibility with specific equipment must be decided by the person who designs the equipment or decides its specifications based on necessary analysis and test results. The expected performance and safety assurance of the equipment will be the responsibility of the person who has determined its compatibility with the product. This person should also continuously review all specifications of the product referring to its latest catalog information, with a view to giving due consideration to any possibility of equipment failure when configuring the equipment.

2. Only personnel with appropriate training should operate machinery and equipment.

The product specified here may become unsafe if handled incorrectly. The assembly, operation and maintenance of machines or equipment including our products must be performed by an operator who is appropriately trained and experienced.

3. Do not service or attempt to remove product and machinery/equipment until safety is confirmed.

1. The inspection and maintenance of machinery/equipment should only be performed after measures to prevent falling or runaway of the driven objects have been confirmed.
2. When the product is to be removed, confirm that the safety measures as mentioned above are implemented and the power from any appropriate source is cut, and read and understand the specific product precautions of all relevant products carefully.
3. Before machinery/equipment is restarted, take measures to prevent unexpected operation and malfunction.

4. Our products cannot be used beyond their specifications. Our products are not developed, designed, and manufactured to be used under the following conditions or environments. Use under such conditions or environments is not covered.

1. Conditions and environments outside of the given specifications, or use outdoors or in a place exposed to direct sunlight.
2. Use for nuclear power, railways, aviation, space equipment, ships, vehicles, military application, equipment affecting human life, body, and property, fuel equipment, entertainment equipment, emergency shut-off circuits, press clutches, brake circuits, safety equipment, etc., and use for applications that do not conform to standard specifications such as catalogs and operation manuals.
3. Use for interlock circuits, except for use with double interlock such as installing a mechanical protection function in case of failure. Please periodically inspect the product to confirm that the product is operating properly.



Safety Instructions

Caution

We develop, design, and manufacture our products to be used for automatic control equipment, and provide them for peaceful use in manufacturing industries.

Use in non-manufacturing industries is not covered.

Products we manufacture and sell cannot be used for the purpose of transactions or certification specified in the Measurement Act.

The new Measurement Act prohibits use of any unit other than SI units in Japan.

Limited warranty and Disclaimer/Compliance Requirements

The product used is subject to the following “Limited warranty and Disclaimer” and “Compliance Requirements”. Read and accept them before using the product.

Limited warranty and Disclaimer

1. The warranty period of the product is 1 year in service or 1.5 years after the product is delivered, whichever is first.*2)
Also, the product may have specified durability, running distance or replacement parts. Please consult your nearest sales branch.
2. For any failure or damage reported within the warranty period which is clearly our responsibility, a replacement product or necessary parts will be provided.
This limited warranty applies only to our product independently, and not to any other damage incurred due to the failure of the product.
3. Prior to using SMC products, please read and understand the warranty terms and disclaimers noted in the specified catalog for the particular products.

***2) Vacuum pads are excluded from this 1 year warranty.**

A vacuum pad is a consumable part, so it is warranted for a year after it is delivered.

Also, even within the warranty period, the wear of a product due to the use of the vacuum pad or failure due to the deterioration of rubber material are not covered by the limited warranty

Compliance Requirements

1. The use of SMC products with production equipment for the manufacture of weapons of mass destruction (WMD) or any other weapon is strictly prohibited.
2. The exports of SMC products or technology from one country to another are governed by the relevant security laws and regulations of the countries involved in the transaction. Prior to the shipment of a SMC product to another country, assure that all local rules governing that export are known and followed.

1. Product Specific Precautions 1



Common Specific Precautions 1

Be sure to read before handling.

Precautions on Design



Warning

- All models

1. The body material is SCS13, the bellows is SUS316L, and other metal seal material is SUS304. Standard seal material in the vacuum section is FKM that can be changed to the other materials (please refer "How to Order"). Use fluids those are compatible with using materials after confirming.
2. Select materials for the actuation pressure piping, and heat resistance for fittings that are suitable for the applicable operating temperatures.

- Models with auto switch

1. The switch section should be kept at the temperature no greater than 60 °C.

Selection



Caution

- All models

1. When controlling valve responsiveness, take note of the size and length of piping, as well as the flow rate characteristics of the actuating solenoid valve.
2. Actuating press should be kept within the specified range. 0.4MPa to 0.5MPa is recommended.
3. Use within the limits of the operating pressure range.

- High temperature types

1. In the case of gases which cause a large amount of deposits, heat the valve body to prevent deposits in the valve.

Mounting



Caution

- All models

1. In high humidity environments, keep valves packed until the time of installation.
2. In case with switches, secure the lead wires so that they have sufficient slack, without any unreasonable force applied to them.
3. Perform piping so that excessive force is not applied to the flange sections. In case there is vibration of heavy objects or attachments, secure them so that torque is not applied directly to the flanges.
4. Vibration resistance allows for normal operation of up to 30 m/s² (45 to 250Hz), but continuous vibration may cause a decline in durability.
Arrange piping to avoid excessive vibration or impacts.

- High temperature types; (Temperature specifications/H0)

1. When a valve is to be heated, only the body section should be heated, excluding the bonnet section.

Piping



Caution

1. Before mounting, clean the surface of the flange seal and the O-ring with ethanol, etc.
2. There is an indentation of 0.1 to 0.2mm in order to protect the flange seal surface, and it should be handled so that the seal surface is not damaged in any way.

 **Warning**

If the fluid or reaction product (deposit) may cause the valve to become unsafe, the valve should be disassembled, cleaned and re-assembled by an operator who has sufficient knowledge and experience (e.g. a specialist).

 **Caution**

1. When removing deposits from the a valve, take care not to damage any part of its parts.
2. Replace the bonnet assembly and the O-ring when the end of its service life is approached.
*For details regarding endurance cycles, please reference Section 5 of this Operation manual titled Period and scope of warranty . (pages 10)
3. If damage is suspected prior to the end of the service life, perform early maintenance.
4. SMC specified parts should be used for service. Refer to the Construction / Maintenance parts table.
5. When removing the valve seal and external seal, take care not to damage the sealing surfaces. When installing the valve seal and external seal, be sure that the O-ring is not twisted. (Refer to Section 6 Parts Replacement Procedure (pages 11 to 13) for details.)

2. Product Specific Precautions 2



Common Specific Precautions 2

Be sure to read before handling

Maintenance Parts



Caution

Only SMC specified parts should be used. Please refer to operation manual.

The bonnet assembly should also be replaced when changing the seal material. Due to the different materials used, changing only the seal may prove inadequate.

Bonnet assembly/construction part number:1

Temperature specifications	Indicator	Valve size			
		16	25	40	50
General use	without	XLA16-30-1	XLA25-30-1	XLA40-30-1	XLA50-30-1
	with	XLA16A-30-1	XLA25A-30-1	XLA40A-30-1	XLA50A-30-1
High temperature	without	XLA16-30-1H	XLA25-30-1H	XLA40-30-1H	XLA50-30-1H
	with	XLA16A-30-1H	XLA25A-30-1H	XLA40A-30-1H	XLA50A-30-1H

Temperature specifications	Indicator	Valve size	
		63	80
General use	without	XLA63-30-1	XLA80-30-1
	with	XLA63A-30-1	XLA80A-30-1
High temperature	without	XLA63-30-1H	XLA80-30-1H
	with	XLA63A-30-1H	XLA80A-30-1H

Note1) The magnet for auto switch is not provided. When the magnet for auto switch is necessary, add "-M9/" at the suffix of the part number. (Not available for high temperature models)

Note2) An auto switch for high temperature is available with a different part number.

Note3) List the optional seal material symbol after the model number, except for the standard seal material (FKM: compound No. 1349-80).

Note4) The bonnet assembly includes the valve seal.

External seal, valve seal

Description Constructions No.	Material	Valve size			
		16	25	40	50
External seal 3	Standard	AS568-025V	AS568-030V	AS568-035V	AS568-039V
	Specific	AS568-025 **	AS568-030 **	AS568-035 **	AS568-039 **
Valve seal 2	Standard	B2401-V15V	B2401-V24V	B2401-P42V	AS568-227V
	Specific	B2401-V15 **	B2401-V24 **	B2401-P42 **	AS568-227 **

Description Construction No.	Material	Valve size	
		63	80
External seal 3	Standard	AS568-043V	AS568-045V
	Specific	AS568-043 **	AS568-045 **
Valve seal 2	Standard	AS568-233V	B2401-V85V
	Specific	AS568-233 **	B2401-V85 **

Note1) List the optional seal material symbol after the model number, except for the standard seal material (FKM: compound no. 1349-80).

Note2) Refer to the Construction on the page 9 for the construction numbers.

Note3) Please contact SMC if you would like to change the material of the valve seal from ULTIC ARMOR to another material, or from another material to ULTIC ARMOR.

Optional seal material

Seal material	EPDM	Barrel Perfluoro®	Kalrez®	Chemraz®			VMQ	FKM for PLASMA	ULTIC ARMOR®	FKM
Combination No.	2101-80	70W	4079	SS592	SS630	SSE38	1232-70	3310-75	UA4640	※
Symbol	-XN1	-XP1	-XQ1	-XR1	-XR2	-XR3	-XS1	-XT1	-XU1	-XF1

Note1) Due to the different materials used, changing only the seal may prove inadequate.

Barrel Perfluoro® is a registered trademark of MATSUMURA OIL Co.,Ltd.

Kalrez® is a registered trademark of the E.I. du Pont de Nemours and Company or its affiliates.

Chemraz® is a registered trademark of the Greene, Tweed Technologies, inc.

ULTIC ARMOR® is a registered trademark of the VALQUA, L

※ Same specifications as the standard FKM type

3. Specifications

Model Note 1		XMA-16	XMA-25 XYA-25	XMA-40 XYA-40	XMA-50 XYA-50	XMA-63 XYA-63	XMA-80 XYA-80	
Flange (valve) size		16,CF034	25	40,CF070	50	63,CF114	80	
Actuating type		Normally closed (Pressurize to open , spring seal)						
Fluid		Vacuum of inert gas						
Operating temperature °C		5 to 60 (High temperature type:5 to 150)						
Operating pressure Pa(abs)		Atmospheric pressure to 1×10^{-6}						
Conductance l/s Note 2		5	14	45	80	160	200	
Leakage Pa m ³ /s	Internal	1.3 x 10 ⁻¹⁰ for the standard material (FKM) at ambient temperatures , excluding gas permeation						
	External	1.3 x 10 ⁻¹¹ for the standard material (FKM) at ambient temperatures , excluding gas permeation						
Flange type	XMA	KF(NW),CF	KF(NW)	KF(NW),CF	KF(NW)	KF(NW),K(DN) ,CF	KF(NW), K(DN)	
	XYA	-	KF(NW)	KF(NW)	KF(NW)	KF(NW) K(DN)	KF(NW) K(DN)	
Main material		Body: SCS13(Stainless) Bellows: SUS316L, Main part: SUS304 and FKM (standard sealing material)						
Actuation pressure MPa(G)		0.4 to 0.7						
Air consumption cm ³ Note 3	At 0.5MPa	19	46	200	360	660	1350	
Port size		M5			Rc 1/8			
Weight Note 4	kg	XMA	0.33 (0.37)	0.61	1.40 (1.76)	2.00	3.60 (4.96)	6.20
			XYA	-	0.66	1.42	2.4	4.30

Note1) XYA-16 is not available due to the interference of the flange shape

Note2) The conductance is “molecular flow” measured with an elbow pipe which has the same dimension with each flange.

Note3) Air consumed by a reciprocating motion of a cylinder.

Note4) Figures in () indicates the weight of CF , conflate fittings.

4. Construction / Dimensions

4-1. Construction

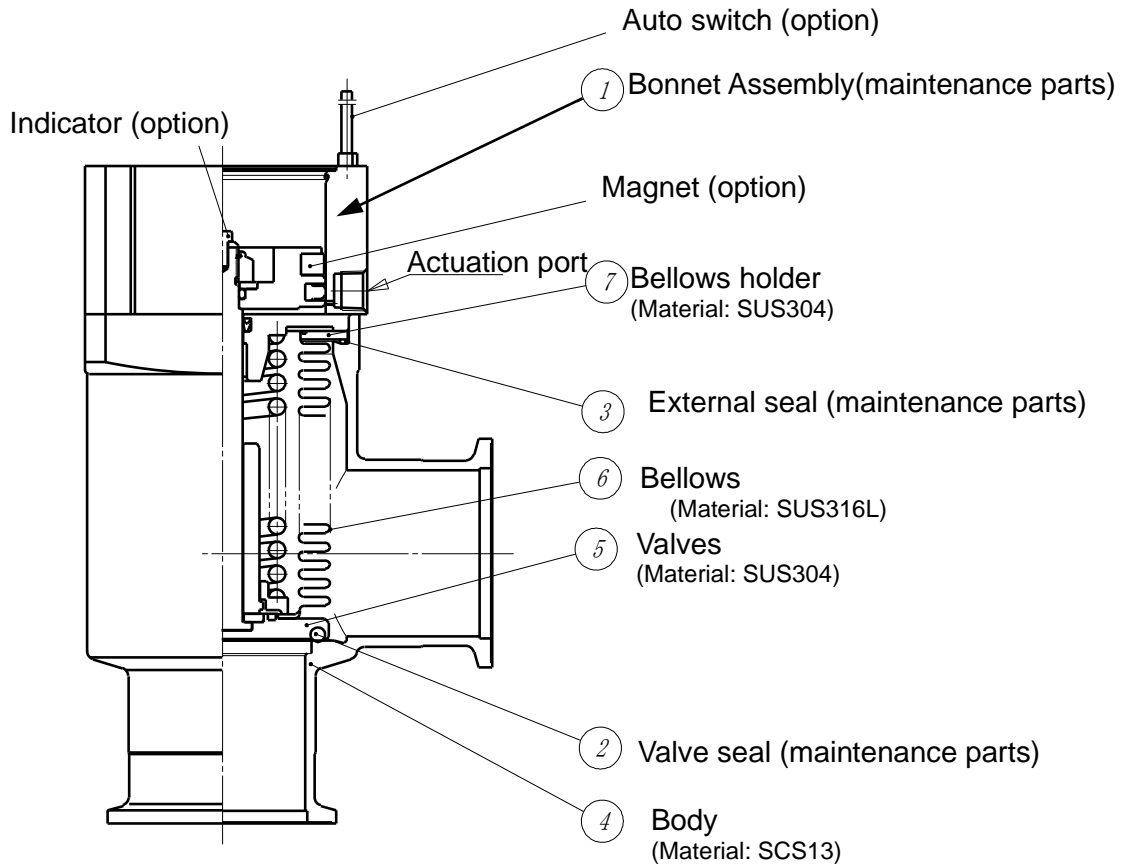

XMA series / Angled Valve

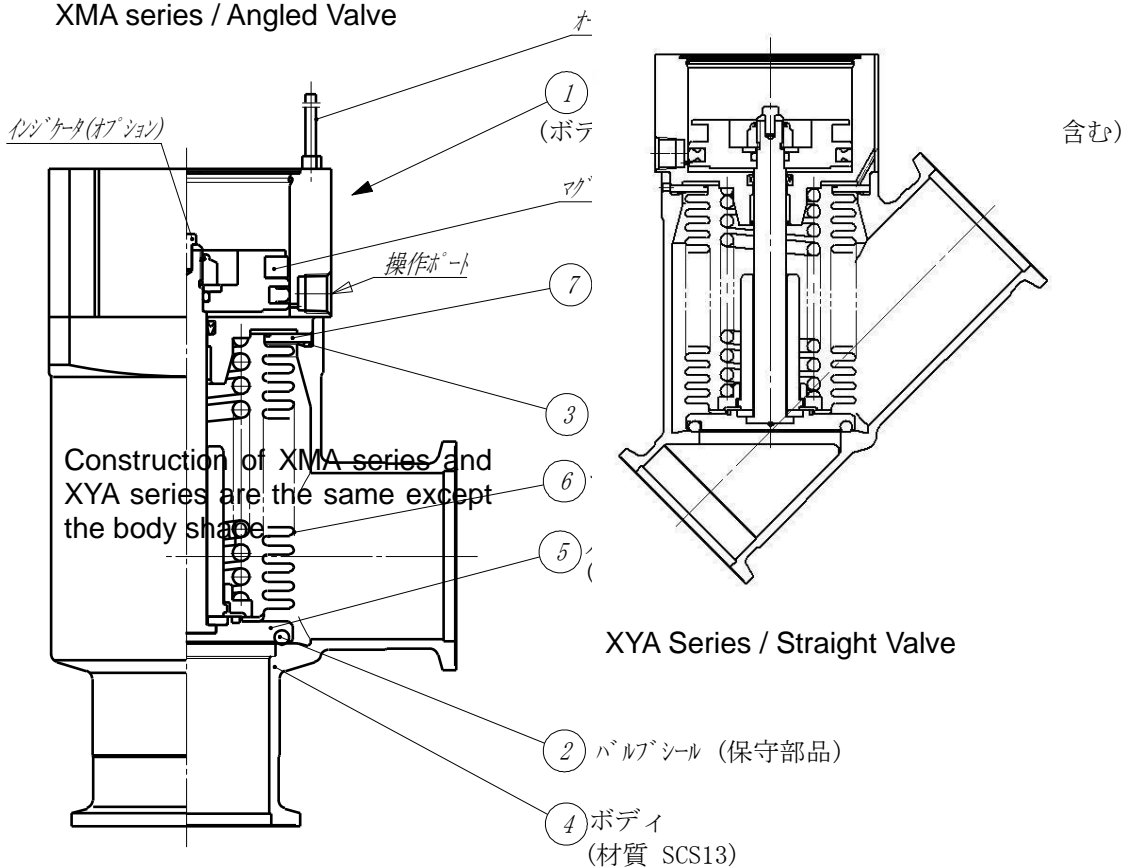

4-2. Exterior dimensions

XMA Series /
Angle Valve

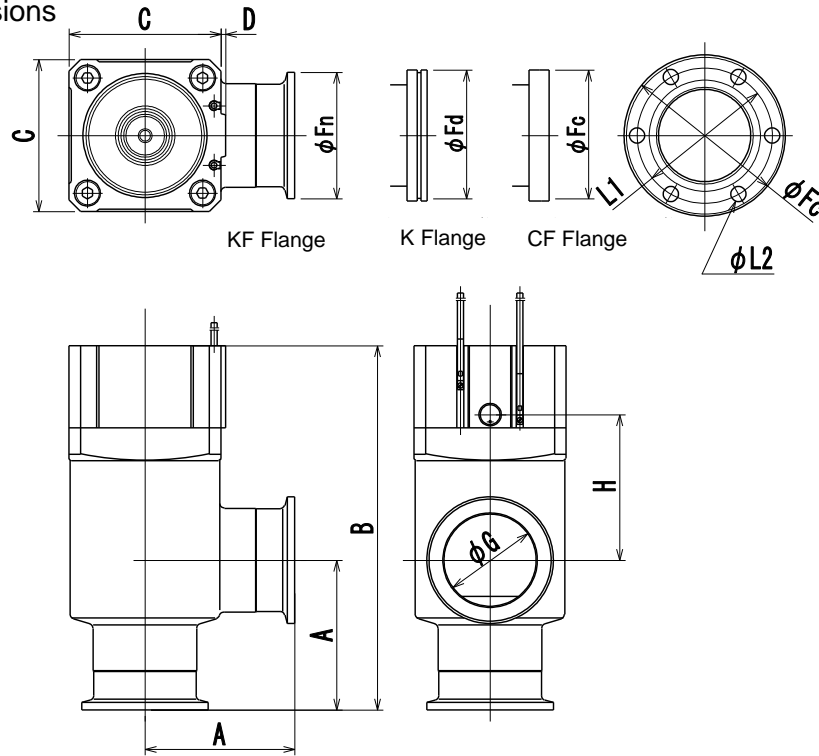

Unit:mm

Model	A	B	C	D	F_n	F_d	F_c	G	H	P.C.D. L1	L2
XMA-16	40	103	38	1	30	-	34	17	40	P.C.D. 27	6x ϕ 4.4
XMA-25	50	113	48	1	40	-	-	26	39	-	-
XMA-40	65	158	66	2	55	-	70	41	63	P.C.D. 58.7	6x ϕ 6.6
XMA-50	70	170	79	2	75	-	-	52	68	-	-
XMA-63	88	196	100	3	87	95	114	70	69	P.C.D. 92.1	8x ϕ 8.4
XMA-80	90	235	117	3	114	110	-	83	96	-	-

XYA Series / Straight Valve

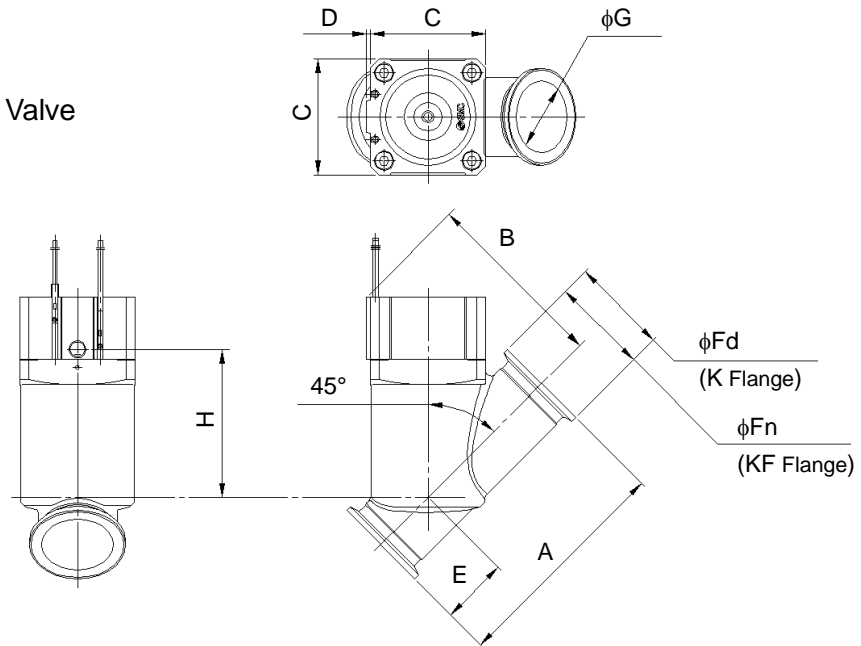

Model	A	B	C	D	E	F_n	F_d	G	H
XYA-25	100.2	79.5	48	1	23.5	40	-	26	64
XYA-40	130	106	66	2	38	55	-	41	84
XYA-50	178	119	79	2	53	75	-	52	95
XYA-63	209	149	100	3	61	87	95	70	118
XYA-80	268	178	117	3	80	114	110	83	142

5. Period and Scope of Warranty

The warranty period is 2,000,000 cycles (under SMC's endurance test conditions), 1 year in service or within 1.5 years after delivery, whichever comes first.

If the valve has been used outside of the specifications, or if a failure occurs as a result of mounting onto a machine or replacement of an assembly, seals, or etc. by the user, the warranty will not be applied.

Note) The endurance of the product will depend on the operating conditions (such as if the flow rate is large).

For any failure reported within the warranty period which is clearly our responsibility, the whole valve will be replaced. This guarantee does not apply to any damage incurred due to the failure of the valve.

Result of durability test (with the circuit shown on the right)

Internal/ external leakage and operation were checked by opening and closing a valve in internally evacuated condition at ordinary temperature (room temperature).

It was confirmed that this product satisfied the specification up to 2 million cycles.

The test was performed with FKM, the standard sealing material.

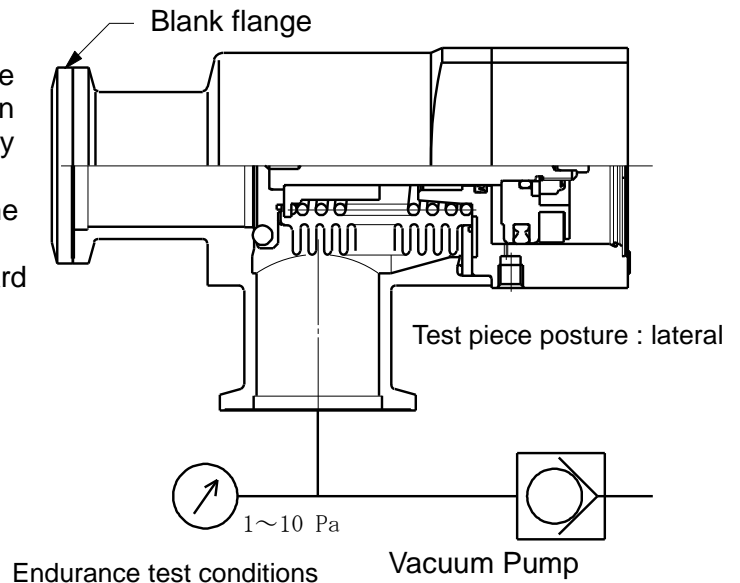

<Reference>

The pumping direction is not limited, but if the pumping creates a flow stream, the durability of the product could be impaired.

Therefore, the pumping direction shown on the right figure (bellows side pumping) is recommended. Also, the operating conditions should be checked beforehand because it affects the life.

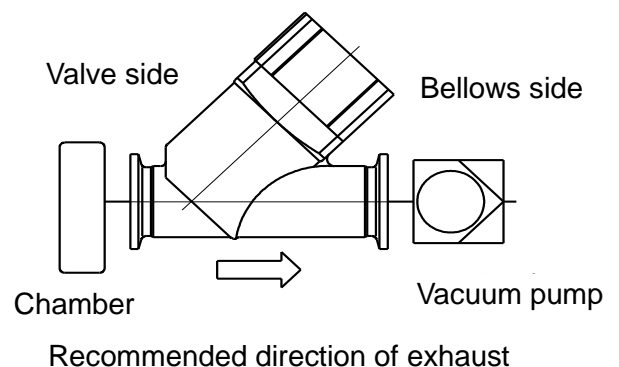
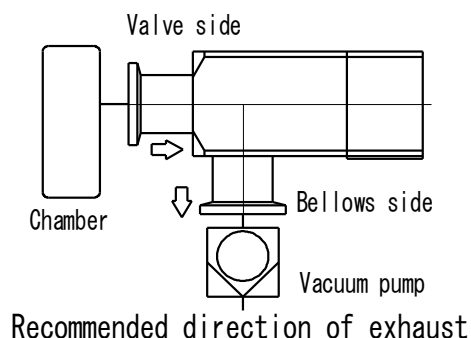

6. Parts Replacement Procedure

6-1. Precautions

Be sure to follow [1. Precautions 1] when disassembling the product for maintenance. Along with the precautions above, comply with the following precautions too.

Warning

- If it is expected that product materials may get stuck to the product, ensure safety is assured before handling. It is recommended to wear gloves and a mask.
- Pay attention to the handling of components according to the procedure in the next item onwards. Do not apply excessive force or impact. This will not only damage the product but also decrease its performance and life expectancy.
- It is not possible to disassemble the bonnet assembly of this product. If the components and assembly are damaged, or damage is expected, exchange the bonnet assembly itself.
- Do not disassemble the parts that are not explained in this operation manual. The performance and life may decrease. Also, it may cause danger.
- **Torque values specified in this manual must be followed.** Not adhering to these specifications, can result in damage to the product.

6-2. Disassembly procedure

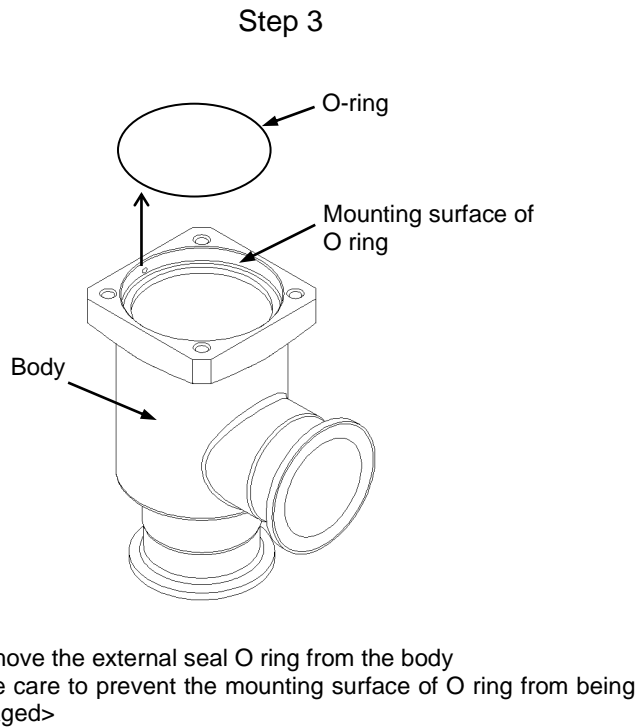
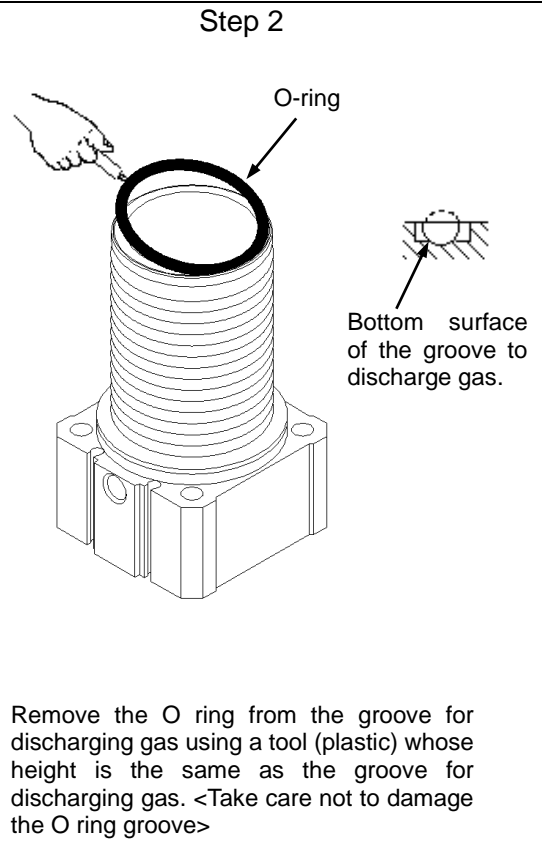
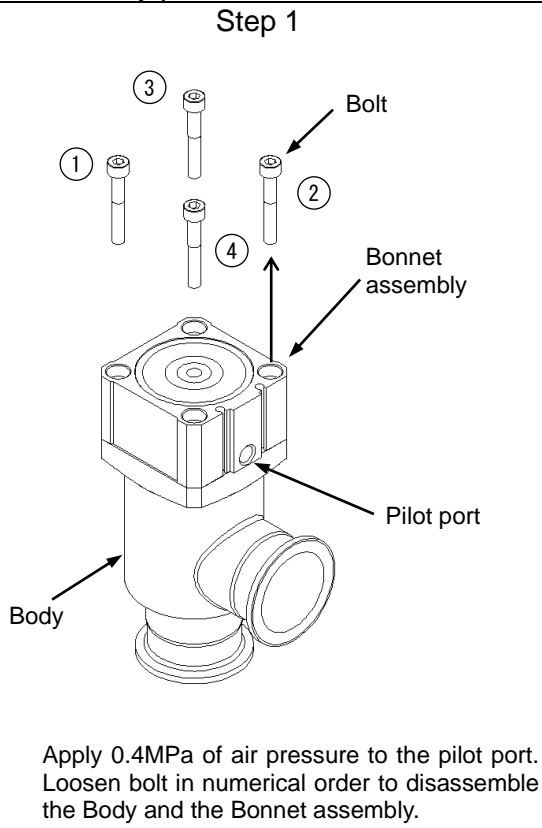

6-3. Assembly Procedure

Step 1

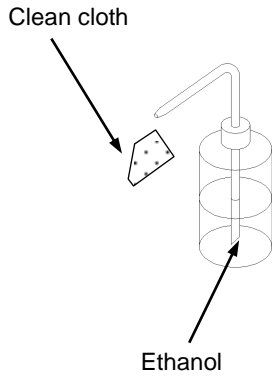

Assemble parts eliminating dust. Wipe off dust with a clean cloth soaked with ethanol. Blow parts with clean air if necessary. <Ensure there is no fiber or dust>

Step 2

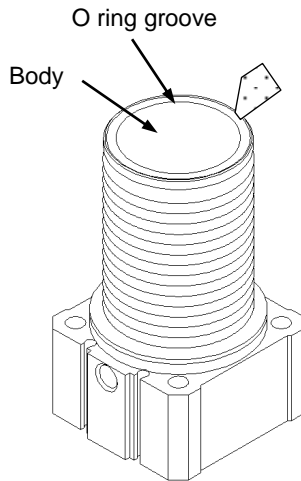

Eliminate the dust of O ring groove of pilot valve.

Step 3

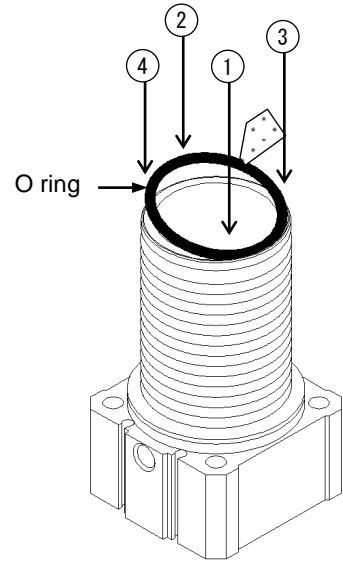

Wipe off the dust on the valve seal O ring surface. Place the O ring on the O ring groove. Press the O-ring into the groove in numerical order (press diagonally) to fit the O-ring into the groove. Take care not to twist the O ring. <Use dust-free gloves>

Step 4

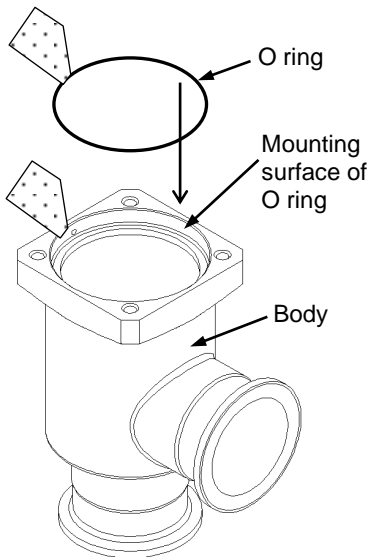

Wipe off the dust from the external seal O ring surface and the mounting surface of the body O ring. Place the O ring on the O ring mounting surface.

Step 5

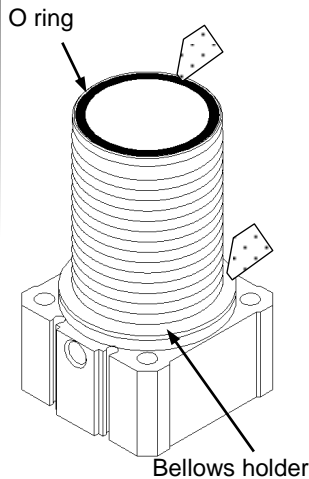

Wipe off any dust from the valve seal O-ring and the Bellows holder surface.

Step 6

Tightening torque N · m	
Valves Size	Tightening Torque
X*A-25	1.5
-40	2.5
-50	6
-63	6
-80	15

Apply 0.4MPa of air pressure to the pilot port. Tighten bolt in numerical order to assemble the Body and the Bonnet assembly. Manually tighten bolts until O-ring is compressed. Perform final torque with same numerical order.

Revision history

A	Limited warranty and Disclaimer	2013.01
B	Front cover, back cover, safety precautions Correction	2024.08

1st Printing :2011.8

SMC Corporation

Tel: + 81 3 5207 8249 Fax: +81 3 5298 5362
URL <https://www.smcworld.com>

Note: Specifications are subject to change without prior notice and any obligation on the part of the manufacturer.
© SMC Corporation All Rights Reserved