



Operation Manual

PRODUCT NAME

Vacuum Angle Valve(Vacuum Pilot)

MODEL / Series / Product Number

XLJ- $\begin{matrix} 25 \\ 40 \end{matrix}$ -*G1 Series

SMC Corporation

Contents

Safety Instructions	-----	2
1. Product Specific Precautions 1 (Precautions on Design, Selection, Mounting, Piping, Wiring, Maintenance)	-----	4
2. Product Specific Precautions 2 (Maintenance parts)	-----	5
3. Specifications	-----	6
4 Construction and Outer dimensions	-----	7
5. Period and scope of warranty	-----	8
6. Parts replacement procedure	-----	9



Safety Instructions

These safety instructions are intended to prevent hazardous situations and/or equipment damage. These instructions indicate the level of potential hazard with the labels of “**Caution**,” “**Warning**” or “**Danger**.” They are all important notes for safety and must be followed in addition to International Standards (ISO/IEC)*1), and other safety regulations.

*1) ISO 4414: Pneumatic fluid power - General rules and safety requirements for systems and their components
ISO 4413: Hydraulic fluid power - General rules and safety requirements for systems and their components
IEC 60204-1: Safety of machinery - Electrical equipment of machines - Part 1: General requirements
ISO 10218-1: Robots and robotic devices - Safety requirements for industrial robots - Part 1: Robots
etc.



Danger

Danger indicates a hazard with a high level of risk which, if not avoided, will result in death or serious injury.



Warning

Warning indicates a hazard with a medium level of risk which, if not avoided, could result in death or serious injury.



Caution

Caution indicates a hazard with a low level of risk which, if not avoided, could result in minor or moderate injury.



Warning

1. The compatibility of the product is the responsibility of the person who designs the equipment or decides its specifications.

Since the product specified here is used under various operating conditions, its compatibility with specific equipment must be decided by the person who designs the equipment or decides its specifications based on necessary analysis and test results. The expected performance and safety assurance of the equipment will be the responsibility of the person who has determined its compatibility with the product. This person should also continuously review all specifications of the product referring to its latest catalog information, with a view to giving due consideration to any possibility of equipment failure when configuring the equipment.

2. Only personnel with appropriate training should operate machinery and equipment.

The product specified here may become unsafe if handled incorrectly. The assembly, operation and maintenance of machines or equipment including our products must be performed by an operator who is appropriately trained and experienced.

3. Do not service or attempt to remove product and machinery/equipment until safety is confirmed.

1. The inspection and maintenance of machinery/equipment should only be performed after measures to prevent falling or runaway of the driven objects have been confirmed.
2. When the product is to be removed, confirm that the safety measures as mentioned above are implemented and the power from any appropriate source is cut, and read and understand the specific product precautions of all relevant products carefully.
3. Before machinery/equipment is restarted, take measures to prevent unexpected operation and malfunction.

4. Our products cannot be used beyond their specifications. Our products are not developed, designed, and manufactured to be used under the following conditions or environments. Use under such conditions or environments is not covered.

1. Conditions and environments outside of the given specifications, or use outdoors or in a place exposed to direct sunlight.
2. Use for nuclear power, railways, aviation, space equipment, ships, vehicles, military application, equipment affecting human life, body, and property, fuel equipment, entertainment equipment, emergency shut-off circuits, press clutches, brake circuits, safety equipment, etc., and use for applications that do not conform to standard specifications such as catalogs and operation manuals.
3. Use for interlock circuits, except for use with double interlock such as installing a mechanical protection function in case of failure. Please periodically inspect the product to confirm that the product is operating properly.



Safety Instructions

Caution

We develop, design, and manufacture our products to be used for automatic control equipment, and provide them for peaceful use in manufacturing industries.

Use in non-manufacturing industries is not covered.

Products we manufacture and sell cannot be used for the purpose of transactions or certification specified in the Measurement Act.

The new Measurement Act prohibits use of any unit other than SI units in Japan.

Limited warranty and Disclaimer/Compliance Requirements

The product used is subject to the following “Limited warranty and Disclaimer” and “Compliance Requirements”. Read and accept them before using the product.

Limited warranty and Disclaimer

1. The warranty period of the product is 1 year in service or 1.5 years after the product is delivered, whichever is first.*2)
Also, the product may have specified durability, running distance or replacement parts. Please consult your nearest sales branch.
2. For any failure or damage reported within the warranty period which is clearly our responsibility, a replacement product or necessary parts will be provided.
This limited warranty applies only to our product independently, and not to any other damage incurred due to the failure of the product.
3. Prior to using SMC products, please read and understand the warranty terms and disclaimers noted in the specified catalog for the particular products.

***2) Vacuum pads are excluded from this 1 year warranty.**

A vacuum pad is a consumable part, so it is warranted for a year after it is delivered.

Also, even within the warranty period, the wear of a product due to the use of the vacuum pad or failure due to the deterioration of rubber material are not covered by the limited warranty

Compliance Requirements

1. The use of SMC products with production equipment for the manufacture of weapons of mass destruction (WMD) or any other weapon is strictly prohibited.
2. The exports of SMC products or technology from one country to another are governed by the relevant security laws and regulations of the countries involved in the transaction. Prior to the shipment of a SMC product to another country, assure that all local rules governing that export are known and followed.

1. Product Specific Precautions 1



Common Precautions 1

Be sure to read before handling.

Design



Warning

● All models

1. The material of the body and the bonnet is A6063, the other materials for vacuum is SUS304, brass, equivalent material to SUS405, and PPS, and the seal material is FKM. In addition, the seal material sliding part for vacuum is applied vacuum grease (Y-VAC2).
Use fluids those are compatible with using materials after confirming.
2. Fluctuation of each voltage should be +/- 10% or less.

Selection



Caution

● All models

1. Keep within the specified range of the pilot pressure.
2. Fluid containing foreign matters and oil will cause malfunction and sealing failure. Remove such things from the fluid.

Mounting



Caution

● All models

1. In high humidity environments, keep the valve packed until the time of installation.
2. Perform piping so that excessive force is not applied to the flange sections. When there is vibration from heavy objects or attachments, etc., fix piping so that vibration will not apply torque directly to the flange section.

Piping and wiring



Caution

1. Before mounting, clean the surface of the flange seal and the O-ring with ethanol, etc.
2. There is an indentation of 0.1 to 0.2mm in order to protect the flange seal surface, and it should be handled so that the seal surface is not damaged in any way.
3. This product has piping directionality. Check the vacuum pump side and the chamber side shown on the construction drawing.
4. A wire for wiring should be 0.5 to 1.25mm² or more as reference.
5. In addition, the wire shall not be applied excessive force.
6. The power supply shall be operated together with the power supply for a vacuum pump.

Maintenance



Warning

If the fluid or reaction product (deposit) may cause the valve to become unsafe, the valve should be disassembled, cleaned and re-assembled by an operator who has sufficient knowledge and experience (e.g. a specialist).

Caution

1. Replace the bonnet assembly when the valve is approaching the end of its service life.
*For the endurance cycles, refer to Section 5 (page 8).
2. If damage is suspected prior to the end of the service life, perform early maintenance.
3. SMC specified parts should be used for service. Refer to the Construction / Maintenance parts table.
4. When removing the valve seal and external seal, take care not to damage the sealing surfaces. When installing the valve seal and external seal, be sure that the O-ring is not twisted.
5. Do not block the air release port and the breathing port. If they are blocked, it may cause malfunction. (Refer to 4-1 Structure and 4-2 Dimensions (P8)).

2. Product Specific Precautions 2



Common Precautions 2 Be sure to read before handling

Maintenance Parts



- SMC specified parts should be used for service. Refer to the construction drawing.
1. Replace the bonnet assembly when changing the sealant material. Due to the different materials used, changing only the seal may prove inadequate.

Bonnet assembly

Description Construction no.	Valve size	
	25	40
Bonnet assembly 1	XLJ25-30-*G1	XLJ40-30-*G1

External seal/ valve seal

Description Construction no.	Valve size	
	25	40
External seal 3	AS568-030V	AS568-035V
Valve seal 2	B2401-V24V	B2401-P42V

Note 1) Refer to the Construction of for the construction numbers.

Note 2) A voltage symbol (same as How to Order) is entered into the mark *

3. Specifications

Model	XLJ-25-*G1		XLJ-40-*G1	
Flange (valve) size	25		40	
Actuating type	Normally closed (vacuum pilot)			
Fluid	Evacuation with inert gas			
Operating temperature °C	5~40			
Direction of exhaust	Fixed Note 1			
Operating pressure Pa (abs)	Atmospheric pressure to 1×10^{-2}			
Conductance l/s Note 2	12		45	
Operating power voltage	100VAC, 200VAC, 110VAC, 220VAC, 230VAC, 240VAC, 24VDC, 12VDC			
Electrical entry	Grommet			
Leakage Pa · m ³ /s	Internal	1.3 x 10 ⁻⁸ at ambient temperature, excluding gas penetration		
	External	1.3 x 10 ⁻⁶ at ambient temperature, excluding gas penetration		
Type of flange	KF(NW)			
Main material	Body and bonnet: aluminum alloy, Main parts: SUS304 and FKM Solenoid valve: brass, SUS304, equivalent to SUS405, PPS, and FKM			
Surface treatment for body	Outside: hard anodized Inside: basis material			
Vacuum grease	Fluorine type grease: Y-VAC2			
Weight kg	0.95		1.5	
ON operation (simultaneously with pump) Note 3	Valve opens by vacuum pressure of pump side..			
OFF operation (simultaneously with pump)	Pump side opens to atmosphere after closing the valve.			

Note 1 See "Operation Description" and "Construction Drawing".

Note 2 The conductance is "molecular flow" measured with an elbow pipe which has the same dimension with each flange.

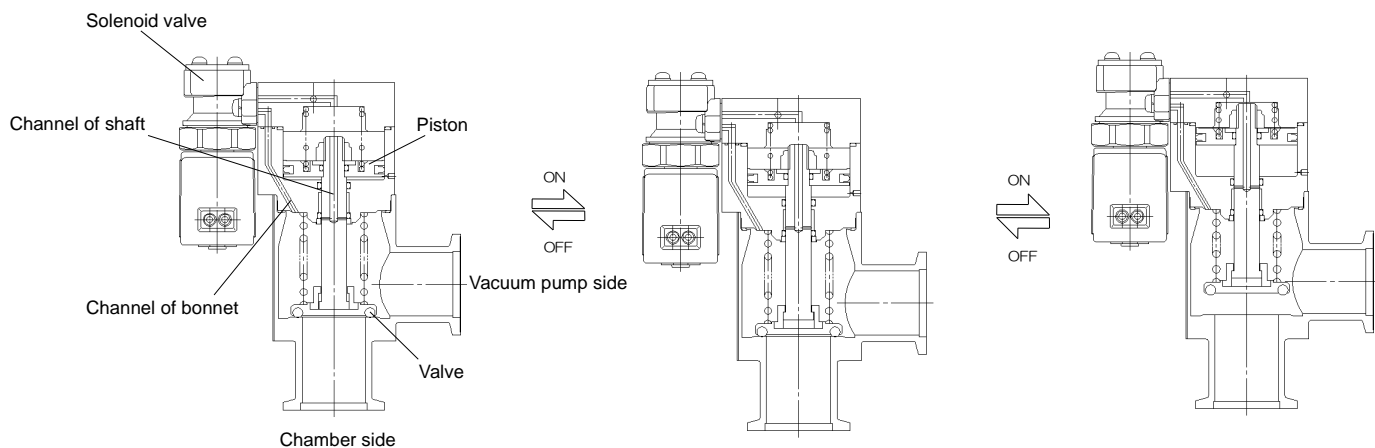

Open valve) When the solenoid valve is energized (simultaneously with the vacuum pump), the atmospheric vent port is closed, and the channel of the bonnet and the top of the piston are opened. If the pressure at the vacuum pump side decreases, the pressure at the top of the piston also decreases via the channels of the shaft and the body. The pressure difference generated at that time makes the piston move upward. If the pressure decreases more, the channel of the shaft is closed, but the pressure at the top of the piston decreases much more via the channel of the bonnet, and it opens the valve.

Close valve) When energizing to the solenoid valve is stopped (simultaneously with the vacuum pump), the channel of the bonnet is closed, and the atmospheric vent port and the top of the piston are opened. As the top of the piston gets atmospheric pressure via the atmospheric vent port, the valve is closed as the piston moves downward with the built-in spring. When the piston moves downward further, the channel of the shaft is opened, and it leads atmosphere to the vacuum pump side.

Note) Valve response depends on the pump capability. Please check and use this valve.

4. Construction and Outer dimensions

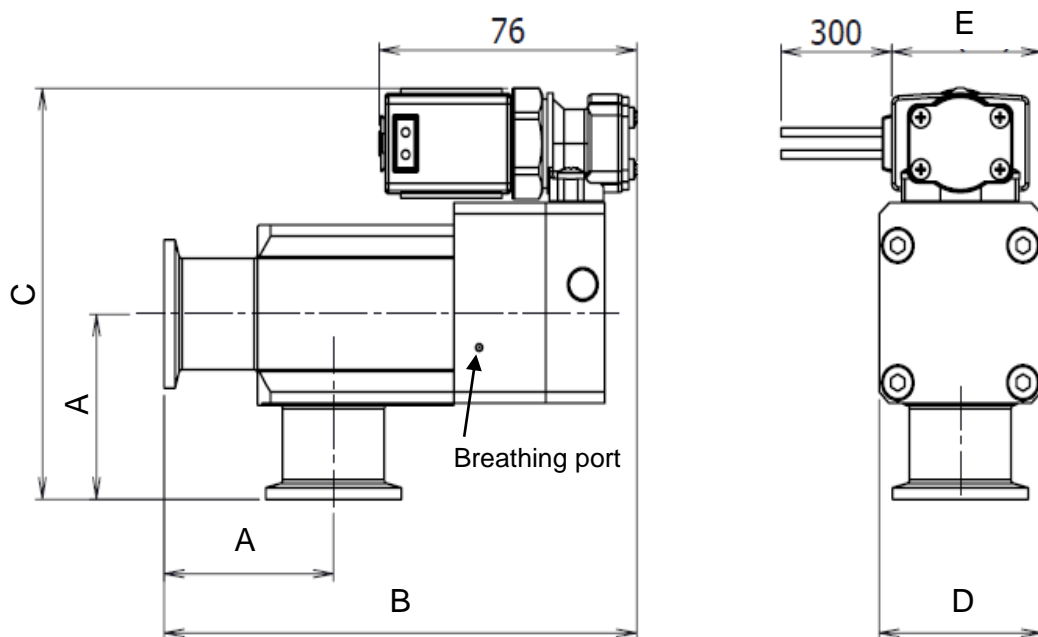
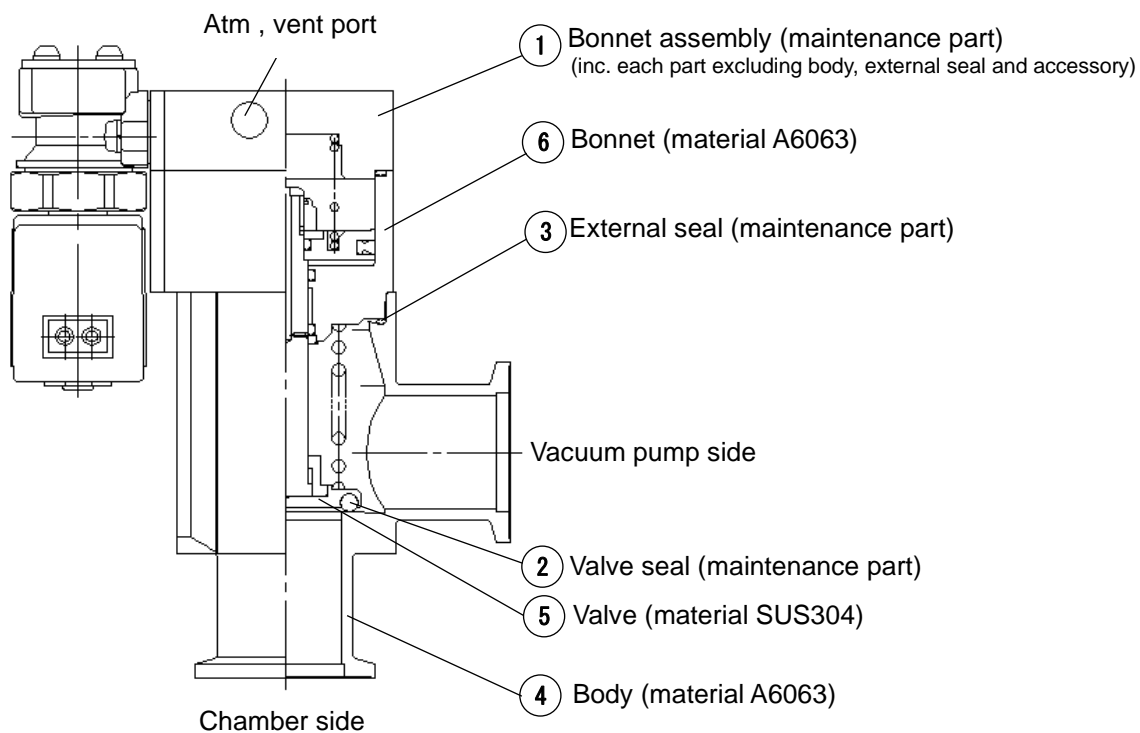

Dimensions [mm]

Model	A	B	C	D	E
XLJ-25	50	139	111	48	44 (54)
XLJ-40	65	168	128	66	53 (63)

Dimension in (brackets) is for AC type.

5. Period and scope of warranty

The guaranteed period covers the period which finishes the earliest among 0.5 million operating cycles [with our durability test conditions], 18 months after shipping from us, and 12 months after starting the use of the product at your place or your customer's place.

Note: The product durability is varied depending on the operating conditions (such as a use with large flow rate).

If the specification is not kept, or any non-conformance derived from mounting or replace of a device, an assembly, or an O-ring at your place occurs, the guarantee cannot be applied.

If any failure occurs due to our fault during the guaranteed period, we will guarantee the non-conformance by delivering a substitute in the worst case. However, responsibility of any damage which is led by the product failure is not taken by us.

Result of durability test

(with the circuit shown on the right)

Internal/ external leakage and operation were checked by opening and closing a valve at room temperature.

It was confirmed that this product Satisfied the specification up to 0.5 million cycles.

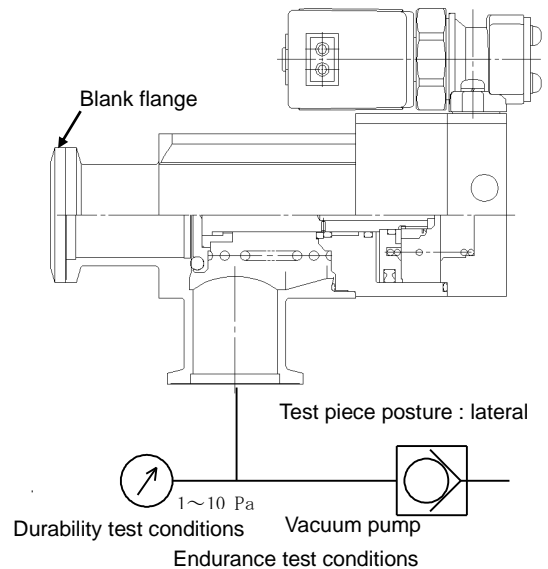

6. Parts Replacement Procedure

6-1. Precautions

Be sure to follow [1. Precautions 1] when disassembling the product for maintenance. Along with the precautions above, comply with the following precautions too.

Warning

- If it is expected that product materials may get stuck to the product, ensure safety is assured before handling. It is recommended to wear gloves and a mask.
- Pay attention to the handling of components according to the procedure in the next item onwards. Do not apply excessive force or impact. This will not only damage the product but also decrease its performance and life expectancy.
- It is not possible to disassemble the bonnet assembly of this product. If the components and assembly are damaged, or damage is expected, exchange the bonnet assembly itself.
- Do not disassemble the parts that are not explained in this operation manual. The performance and life may decrease. Also, it may cause danger.

6-2.Replacement Procedure of the valve seal (O-ring)

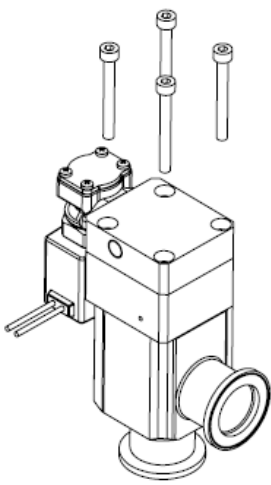
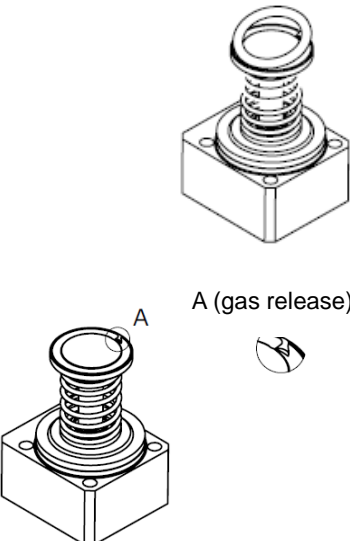
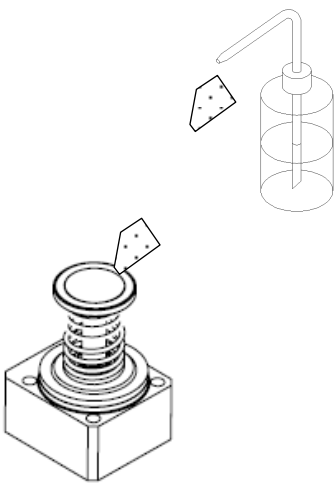
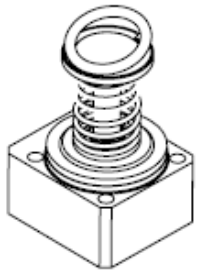
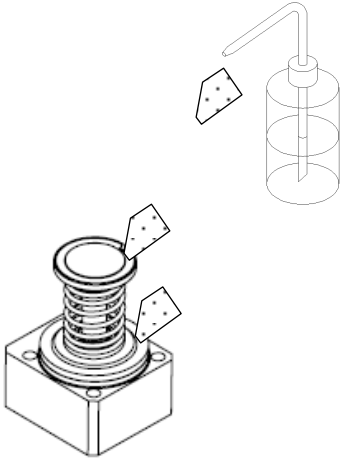
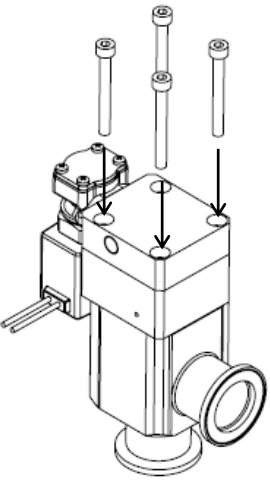
<p style="text-align: center;">Step 1</p>  <p>Loosen the bolts gradually in numerical order (alternately) with bonnet assembly held.</p>	<p style="text-align: center;">Step 2</p>  <p>A (gas release)</p> <p>Remove O-ring from the gas release groove with a tool which height is the same as the groove depth. (Mind not to damage O-ring groove)</p>	<p style="text-align: center;">Step 3</p>  <p>Apply ethanol to a clean cloth (such as BENCOT) to wipe off the dust in O-ring groove. (Ensure neither fiber nor dust is found at all.)</p>
<p style="text-align: center;">Step 4</p>  <p>Apply ethanol to a clean cloth (such as BENCOT) to wipe off dust on O-ring surface, and place the O-ring on the O-ring groove. Press O-ring in numerical order in above drawing (press diagonally) to mount O-ring into the groove. (Put on gloves which generate no particle)</p>	<p style="text-align: center;">Step 5</p>  <p>Apply ethanol to a clean cloth (such as BENCOT) to wipe off dust on O-ring surface and the external seal.</p>	<p style="text-align: center;">Step 6</p>  <p>Tighten the bolts gradually in numerical order (alternately) with bonnet assembly held.</p>

6-3. Replacement Procedure of the External Seal (O-ring)

Step 1

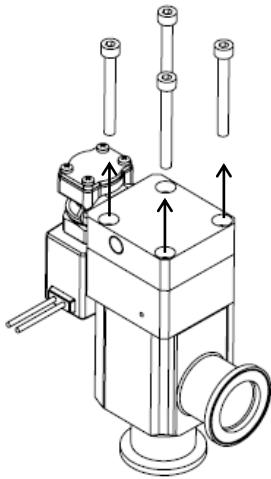

Loosen the bolts gradually in numerical order (alternately) with bonnet assembly held.

Step 2

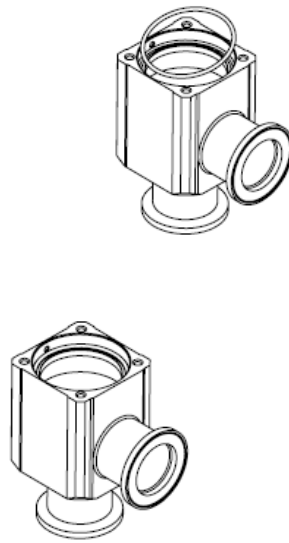

Remove the external seal from the body. (Mind not to damage the body mounting surface.)

Step 3

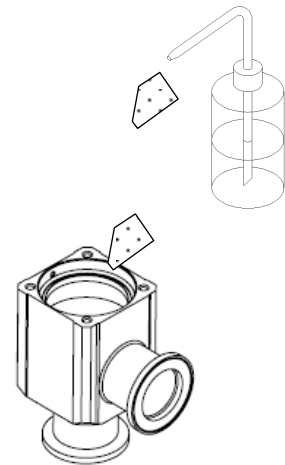

Apply ethanol to a clean cloth (such as BENCOT) to wipe off the dust on the external seal surface and the body mounting surface. Then, mount the external seal.

Step 4

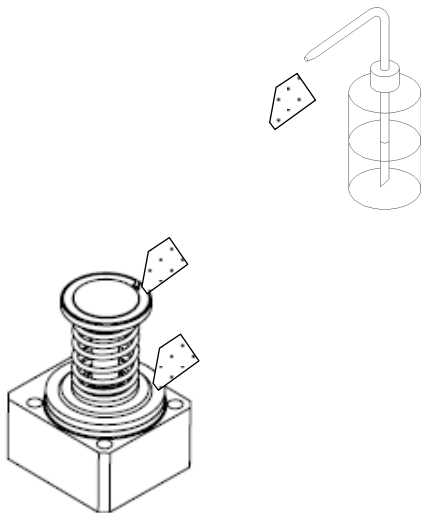

Apply ethanol to a clean cloth (such as BENCOT) to wipe off dust on the O-ring surface and the external seal surface.

Step 5

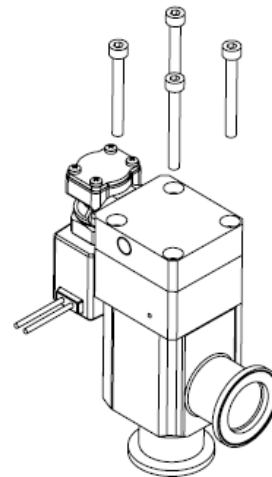

Tighten the bolts gradually in numerical order (alternately) with bonnet assembly held.

Revision history		
A	40 size added	2018.10
B	Front cover, back cover, safety precautions Correction	2024.08

1st Printing :2016.10

SMC Corporation

Tel: + 81 3 5207 8249 Fax: +81 3 5298 5362
 URL <https://www.smcworld.com>

Note: Specifications are subject to change without prior notice and any obligation on the part of the manufacturer.
 © SMC Corporation All Rights Reserved