



Operation Manual

PRODUCT NAME

High Vacuum L Type Valve

MODEL / Series / Product Number

XLFV-2 Series

SMC Corporation

Contents

Safety Instructions	-----	2
1. Product Specific Precautions 1 (Piping, Air Supply)	-----	4
2. Product Specific Precautions 2 (Precautions on Design, Selection, Mounting, Piping, Wiring, Maintenance)	-----	5
3. Product Specific Precautions 3 (Maintenance parts)	-----	7
4. Specifications	-----	9
5. Construction and Dimensions	-----	10
6. Period and Scope of Warranty	-----	12
7. Parts Replacement Procedure	-----	13



Safety Instructions

These safety instructions are intended to prevent hazardous situations and/or equipment damage. These instructions indicate the level of potential hazard with the labels of “**Caution**,” “**Warning**” or “**Danger**.” They are all important notes for safety and must be followed in addition to International Standards (ISO/IEC)^{*1)}, and other safety regulations.

*1) ISO 4414: Pneumatic fluid power - General rules and safety requirements for systems and their components
ISO 4413: Hydraulic fluid power - General rules and safety requirements for systems and their components
IEC 60204-1: Safety of machinery - Electrical equipment of machines - Part 1: General requirements
ISO 10218-1: Robots and robotic devices - Safety requirements for industrial robots - Part 1: Robots
etc.



Danger

Danger indicates a hazard with a high level of risk which, if not avoided, will result in death or serious injury.



Warning

Warning indicates a hazard with a medium level of risk which, if not avoided, could result in death or serious injury.



Caution

Caution indicates a hazard with a low level of risk which, if not avoided, could result in minor or moderate injury.



Warning

1. The compatibility of the product is the responsibility of the person who designs the equipment or decides its specifications.

Since the product specified here is used under various operating conditions, its compatibility with specific equipment must be decided by the person who designs the equipment or decides its specifications based on necessary analysis and test results. The expected performance and safety assurance of the equipment will be the responsibility of the person who has determined its compatibility with the product. This person should also continuously review all specifications of the product referring to its latest catalog information, with a view to giving due consideration to any possibility of equipment failure when configuring the equipment.

2. Only personnel with appropriate training should operate machinery and equipment.

The product specified here may become unsafe if handled incorrectly. The assembly, operation and maintenance of machines or equipment including our products must be performed by an operator who is appropriately trained and experienced.

3. Do not service or attempt to remove product and machinery/equipment until safety is confirmed.

1. The inspection and maintenance of machinery/equipment should only be performed after measures to prevent falling or runaway of the driven objects have been confirmed.
2. When the product is to be removed, confirm that the safety measures as mentioned above are implemented and the power from any appropriate source is cut, and read and understand the specific product precautions of all relevant products carefully.
3. Before machinery/equipment is restarted, take measures to prevent unexpected operation and malfunction.

4. Our products cannot be used beyond their specifications. Our products are not developed, designed, and manufactured to be used under the following conditions or environments. Use under such conditions or environments is not covered.

1. Conditions and environments outside of the given specifications, or use outdoors or in a place exposed to direct sunlight.
2. Use for nuclear power, railways, aviation, space equipment, ships, vehicles, military application, equipment affecting human life, body, and property, fuel equipment, entertainment equipment, emergency shut-off circuits, press clutches, brake circuits, safety equipment, etc., and use for applications that do not conform to standard specifications such as catalogs and operation manuals.
3. Use for interlock circuits, except for use with double interlock such as installing a mechanical protection function in case of failure. Please periodically inspect the product to confirm that the product is operating properly.



Safety Instructions

Caution

We develop, design, and manufacture our products to be used for automatic control equipment, and provide them for peaceful use in manufacturing industries.

Use in non-manufacturing industries is not covered.

Products we manufacture and sell cannot be used for the purpose of transactions or certification specified in the Measurement Act.

The new Measurement Act prohibits use of any unit other than SI units in Japan.

Limited warranty and Disclaimer/Compliance Requirements

The product used is subject to the following “Limited warranty and Disclaimer” and “Compliance Requirements”. Read and accept them before using the product.

Limited warranty and Disclaimer

1. The warranty period of the product is 1 year in service or 1.5 years after the product is delivered, whichever is first.*2)
Also, the product may have specified durability, running distance or replacement parts. Please consult your nearest sales branch.
2. For any failure or damage reported within the warranty period which is clearly our responsibility, a replacement product or necessary parts will be provided.
This limited warranty applies only to our product independently, and not to any other damage incurred due to the failure of the product.
3. Prior to using SMC products, please read and understand the warranty terms and disclaimers noted in the specified catalog for the particular products.

***2) Vacuum pads are excluded from this 1 year warranty.**

A vacuum pad is a consumable part, so it is warranted for a year after it is delivered.

Also, even within the warranty period, the wear of a product due to the use of the vacuum pad or failure due to the deterioration of rubber material are not covered by the limited warranty

Compliance Requirements

1. The use of SMC products with production equipment for the manufacture of weapons of mass destruction (WMD) or any other weapon is strictly prohibited.
2. The exports of SMC products or technology from one country to another are governed by the relevant security laws and regulations of the countries involved in the transaction. Prior to the shipment of a SMC product to another country, assure that all local rules governing that export are known and followed.

1. Product Specific Precautions 1



Precautions 1

Be sure to read before handling.

Piping



Caution

1. Refer to the Fittings and Tubing Precautions on the SMC website for handling One-touch fittings.
2. Before piping is connected, it should be thoroughly blown out with air (flushing) or washed to remove chips, cutting oil and other debris from inside the pipe.
3. When connecting pipes, fittings, etc., be sure that chips from the pipe threads and sealing material do not enter the valve. Furthermore, when sealant tape is used, leave 1.5 to 2 thread ridges exposed at the end of the threads.

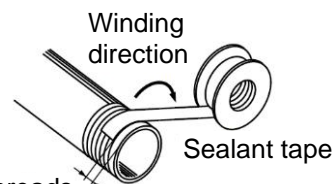

Air Supply



Warning

1. Please consult with SMC when using the product in applications other than compressed air.
2. Compressed air containing a large amount of drainage can cause malfunction of pneumatic equipment. An air dryer or water separator should be installed upstream from filters.
3. If condensation in the drain bowl is not emptied on a regular basis, the bowl will overflow and allow the condensation to enter the compressed air lines. It causes malfunction of pneumatic equipment. If the drain bowl is difficult to check and remove, installation of a drain bowl with an auto drain option is recommended.
4. Do not use compressed air that contains chemicals, synthetic oils including organic solvents, salt or corrosive gases, etc., as it can cause damage or malfunction.



Caution

1. When extremely dry air is used as the fluid, degradation of the lubrication properties inside the equipment may occur, resulting in reduced reliability (or reduced service life) of the equipment. Please consult with SMC.
2. Install an air filter at the upstream side of valve. Select an air filter with a filtration degree of 5 μm or finer.
3. Compressed air that contains a large amount of drainage can cause malfunction of pneumatic equipment such as valves. Therefore, take appropriate measures to ensure air quality, such as by providing an aftercooler, air dryer, or water separator.
4. Ensure that the fluid and ambient temperature are within the specified range. If the fluid temperature is 5°C or less, the moisture in the circuit could freeze, causing damage to the seals and equipment malfunction. Therefore, take appropriate measures to prevent freezing.
5. Moisture condensation can occur inside pneumatic systems due to a drop in temperature caused by the piping or operating conditions. This can degrade or wash away grease, resulting in shortened service life or malfunctions. For details, refer to the catalog "Precautionary measures against condensation in a pneumatic system" (CAT.P-E01-11).

For compressed air quality, refer to the SMC catalog "Air preparation system".

2. Product Specific Precautions 2



Precautions 2 Be sure to read before handling.

This valve (XLFV series) is equipped with a solenoid valve. The solenoid valve is a 3-port solenoid valve SYJ300 or SYJ500 series. Be sure to read the Operation Manuals of this valve and SYJ300 or SYJ500 before use.

Design



Warning

- All models

1. The body material is A6063, and other metal seal material is SUS304 and A2017. Refer to Chapter 5, "Construction and Dimensions" (P. 10) for details.
Standard seal material in the vacuum section is FKM that can be changed to the other materials. (Refer to Chapter 3, "Product Specific Precautions 3" (P. 8) for details.) Grease for vacuum is applied to the sliding part for the seals (Fluorine grease: Y-VAC2).
After confirming the type of material used, be sure to use compatible fluids.
2. Select materials for the actuation pressure piping and heat resistant fittings that are suitable for the applicable operating temperatures.

Selection



Caution

- All models

1. When controlling valve responsiveness, take note of the size and length of piping.
2. Keep the pilot pressure within the specified range.
3. Operate within the specified operating pressure range.
4. Operate within the specified operating temperature range.
5. Please note, when selecting a product without an auto switch(es) (excluding those with built-in magnet), it is not possible to mount an auto switch(es) following receipt of the product from an SMC factory.
6. Keep residual voltage leakage to 3% or less of the rated voltage for DC and 8% or less of the rated voltage for AC.

Mounting



Caution

- All models

1. In high humidity environments, keep the valve packed until the time of installation.
2. For models with switches, secure the lead wires so that they have sufficient slack, without any unreasonable force applied to them.
3. Perform piping so that excessive force is not applied to the flange sections. When there is vibration from heavy objects or attachments, etc., fix piping so that vibration will not apply torque directly to the flange section.
4. Vibration resistance allows for normal operation of up to 30m/s² (45 to 250Hz).
Be advised that continuous vibration may cause a decline in durability.
Arrange piping to avoid excessive vibration or impacts.

- When mounting the fitting to the pilot port, mount it so that the solenoid valve and plate are secured at the same time. Additionally, when replacing the solenoid valve, mount the screws in the same manner. Refer to Chapter 7, "Parts Replacement Procedure" (P. 17) for details.

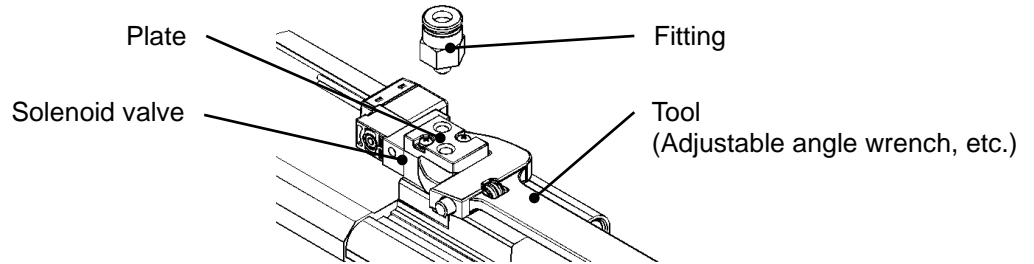

Piping



Caution

- Before mounting, clean the surface of the flange seal and the O-ring with ethanol, etc.
- There is an indentation of 0.1 to 0.2mm designed to protect the flange seal surface. Be careful when handling the product to prevent any damage to the seal surface.

Wiring



Caution

- When the solenoid valve with a DC type light/surge voltage suppressor is electrically connected, check whether there is polarity. If there is polarity, incorrect polarity may cause damage to the elements inside the valve or power supply equipment, and malfunction may result.
- When electric power is connected to the solenoid valve, be careful to apply the proper voltage. Improper voltage may cause a malfunction or the coil to burn out.
- After completing the wiring, confirm that the connections are correct.
- If an excessive force is applied to the lead wire, this may cause faulty wiring. Take appropriate measures so that a force of 30N or more is not applied to the lead wire.

Maintenance



Warning

If the fluid or reaction product (deposit) may cause the valve to become unsafe, the valve should be disassembled, cleaned and re-assembled by an operator who has sufficient knowledge and experience (e.g. a specialist).



Caution

- When removing deposits from the valve, take care not to damage any part of the valve.
- Replace the bonnet assembly when the valve is approaching the end of its service life. Refer to Chapter 6, "Period and Scope of Warranty" (P. 12) for details regarding endurance cycles.
- If potential damages are suspected prior to the end of the service life, perform maintenance earlier than noted. If there are scratches, dents or cracks on the seals (valve seal 1, 2) due to handling or operating conditions, please replace the parts with new ones. Refer to Chapter 3, "Product Specific Precautions 3" (P. 7 to 8) and Chapter 5, "Construction and Dimensions" (P. 10) for maintenance parts. Parts with the indication of "Maintenance part" can be replaced.
- SMC specified parts should be used for service. Refer to the Construction / Maintenance parts table.
- When removing the valve seal and external seal, take care not to damage the sealing surfaces. When installing the valve seal and external seal, be sure that the O-ring is not twisted. (Refer to Chapter 7, "Parts Replacement Procedure" (P. 13 to 17) for details.)

3. Product Specific Precautions 3



Precautions 3 Be sure to read before handling

Maintenance Parts



Caution

SMC specified parts should be used for maintenance service.

Refer to Chapter 5, "Construction and Dimensions" (P. 10) for the part indication numbers.

Bonnet assembly/Part indication number (1)

Indicator	Valve size			
	16	25	40	50
Without	XLFV16-30-1-2	XLFV25-30-1-2	XLFV40-30-1-2	XLFV50-30-1-2
With	XLFV16A-30-1-2	XLFV25A-30-1-2	XLFV40A-30-1-2	XLFV50A-30-1-2

Indicator	Valve size	
	63	80
Without	XLFV63-30-1-2	XLFV80-30-1-2
With	XLFV63A-30-1-2	XLFV80A-30-1-2

Note 1) Add the seal material symbol shown on page 8 at the suffix of the model number. This is not necessary for the standard seal material valve seal 1 and 2 (**FKM: Compound No. 1349-80**).
e.g.) XLFV16A-30-1-2-XN1

Note 2) The magnet for auto switch is not provided. When the magnet for auto switch is necessary, add "-M9/" at the suffix of the part number. (There is no magnet for auto switch for high temperature.)
e.g.) XLFV16-30-1-2M9//

Note 3) Auto switch and solenoid valve are not attached. When a product with an auto switch and solenoid valve is required, add the symbols for the auto switch and solenoid valve to the end of the part number.
e.g.) XLFV16A-30-1-2M9NA-5GS-XN1

Note 4) Bonnet assembly contains the valve seal 1, valve seal 2, and nut assembly. It does not contain external seal. Order separately if it is required.

External seal, Valve seal 1, Valve seal 2

Description Part indication No.	Material	Valve size			
		16	25	40	50
External seal (4)	Standard	AS568-025V	AS568-030V	AS568-035V	AS568-039V
	Special	AS568-025**	AS568-030**	AS568-035**	AS568-039**
Valve seal 1 (2)	Standard	B2401-V15V	B2401-V24V	B2401-P42V	AS568-227V
	Special	B2401-V15**	B2401-V24**	B2401-P42**	AS568-227**
Valve seal 2 (3)	Standard	B2401-P4V	B2401-P5V	B2401-P6V	B2401-P8V
	Special	B2401-P4**	B2401-P5**	B2401-P6**	B2401-P8**

Description Part indication No.	Material	Valve size	
		63	80
External seal (4)	Standard	AS568-043V	AS568-045V
	Special	AS568-043**	AS568-045**
Valve seal 1 (2)	Standard	AS568-233V	B2401-V85V
	Special	AS568-233**	B2401-V85**
Valve seal 2 (3)	Standard	B2401-P8V	B2401-P10V
	Special	B2401-P8**	B2401-P10**

Note 1) Add the seal material symbol shown on page 8 at the end of the model number (in place of **). This is not necessary for the standard seal material (**FKM: Compound No. 1349-80**).
e.g.) AS568-025-XN1

Nut assembly

Description Part indication No.	Valve size	16	25	40	50
Nut assembly (9)		XL1A16-10-1	XL1A25-10-1	XL1A40-10-1	XL1A50-10-1
Description Part indication No.	Valve size	63	80		
Nut assembly (9)		XL1A50-10-1	XL1A80-10-1		

Suffix for seal materials

Seal material	EPDM	Barrel Perfluoro®	Kalrez®	Chemraz®			VMQ	FKM for PLASMA	FKM
Combination No.	2101-80	70W	4079	SS592	SS630	SSE38	1232-70	3310-75	※
Symbol	-XN1	-XP1	-XQ1	-XR1	-XR2	-XR3	-XS1	-XT1	-XF1

Note 1) Barrel Perfluoro® is a registered trademark of MATSUMURA OIL Co.,Ltd.

Kalrez® is a registered trademark of the E.I.du Pont de Nemours and Company or its affiliates.

Chemraz® is a registered trademark of the Greene, Tweed Technologies, inc.

※Same specifications as the standard FKM type

Solenoid valve, Plate assembly

Description Part indication No.	Valve size	16	25	40
Solenoid valve (14)		SYJ319-***		
Plate assembly (15)		XL1AV16-90-2		
Description Part indication No.	Valve size	50	63	80
Solenoid valve (14)		SYJ519-***		
Plate assembly (15)		XLAV63-90-1		

Note 1) The -*** at the end of the solenoid valve part number is the selection symbol for voltage, electrical entry, and other specifications. For details about selection symbols, refer to the Web Catalog.

Note 2) The plate assembly includes the plate, gasket, and mounting screws.

4. Specifications

4-1. Valve specifications

Model	XLFV-16-2	XLFV-25-2	XLFV-40-2	XLFV-50-2	XLFV-63-2	XLFV-80-2	
Flange (valve) size	16	25	40	50	63	80	
Actuating type	Normally closed						
Fluid	Vacuum of inert gas						
Operating temperature °C	5 to 50						
Operating pressure Pa(abs)	Atmospheric pressure to 1×10^{-5}						
Conductance l/s ^{Note 1)}	5	14	45	80	160	200	
Leakage Pa·m ³ /s	Internal	1.3 x 10 ⁻¹⁰ for the standard material (FKM) at ambient temperatures , excluding gas permeation					
	External	1.3 x 10 ⁻¹⁰ for the standard material (FKM) at ambient temperatures , excluding gas permeation					
Flange type	KF (NW)			KF (NW), K (DN)			
Main material ^{Note 2)}	Body: aluminum alloy, Main part: SUS304 and FKM (standard sealant material)						
Surface treatment for body	Outside: hard anodized Inside: basis material						
Actuation pressure MPa(G)	0.4 to 0.7						
Air consumption cm ³ ^{Note 3)}	for 0.5MPa	31	61	220	390	680	1420
Solenoid valve	SYJ319			SYJ519			
Port size	M5: Port1(P), 3(R)			Rc1/8: Port1(P), M5: Port3(R)			
Weight kg	0.34	0.54	1.3	1.9	3.3	5.8	

Note 1) Conductance is "molecular flow" measured with an elbow pipe which has the same dimension as each applicable flange.

Note 2) Grease for vacuum is applied to the sliding part for the seals (Fluorine grease: Y-VAC2).

Note 3) For one cycle of cylinder.

Refer to Web Catalog for details of the solenoid valve.

5. Construction and Dimensions

5-1. Construction

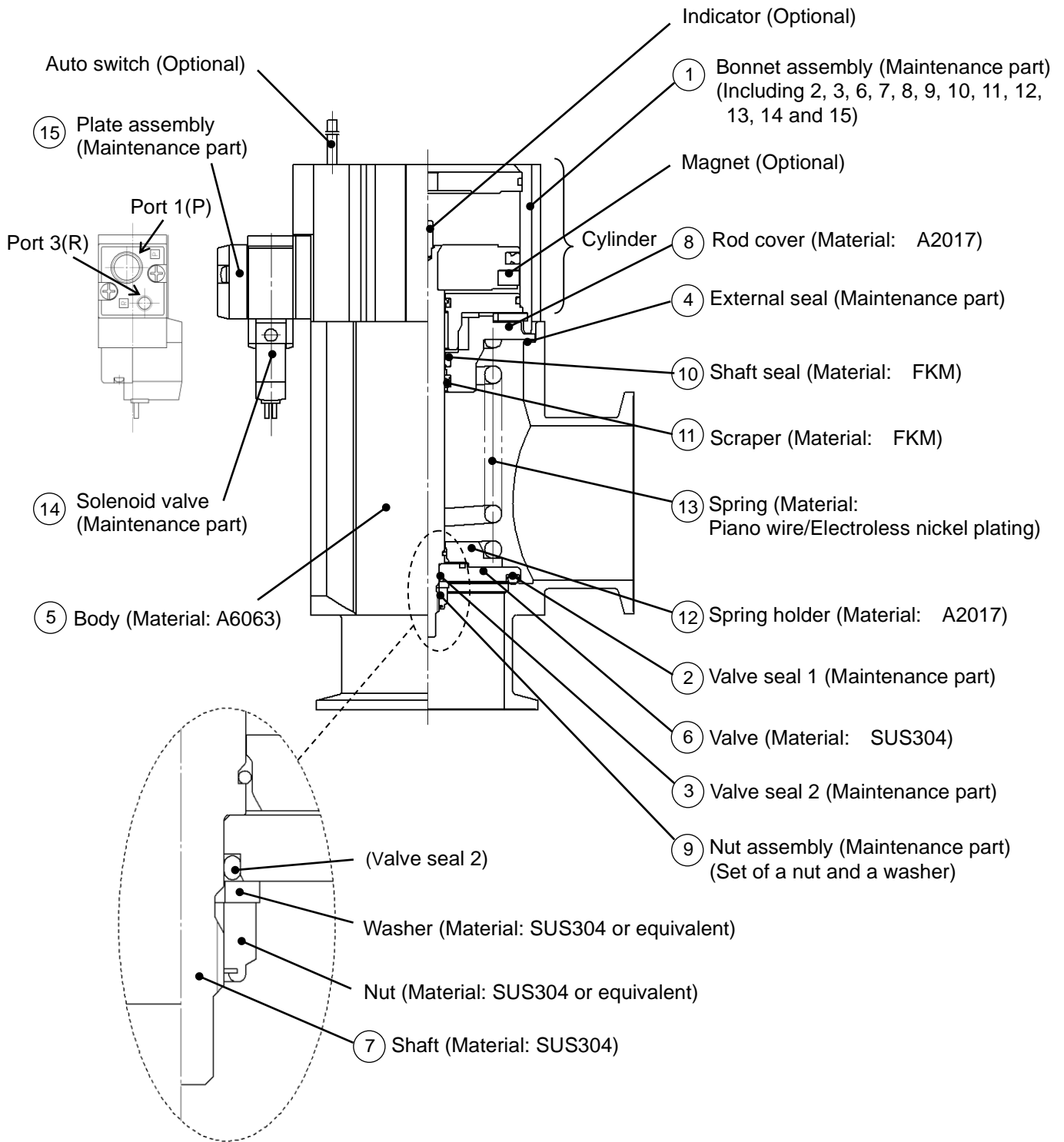

●Working principle

Port 1(P) is normally pressurized, and the valve opens when the solenoid valve is turned ON and closes when it is turned OFF.

5-2.Dimensions

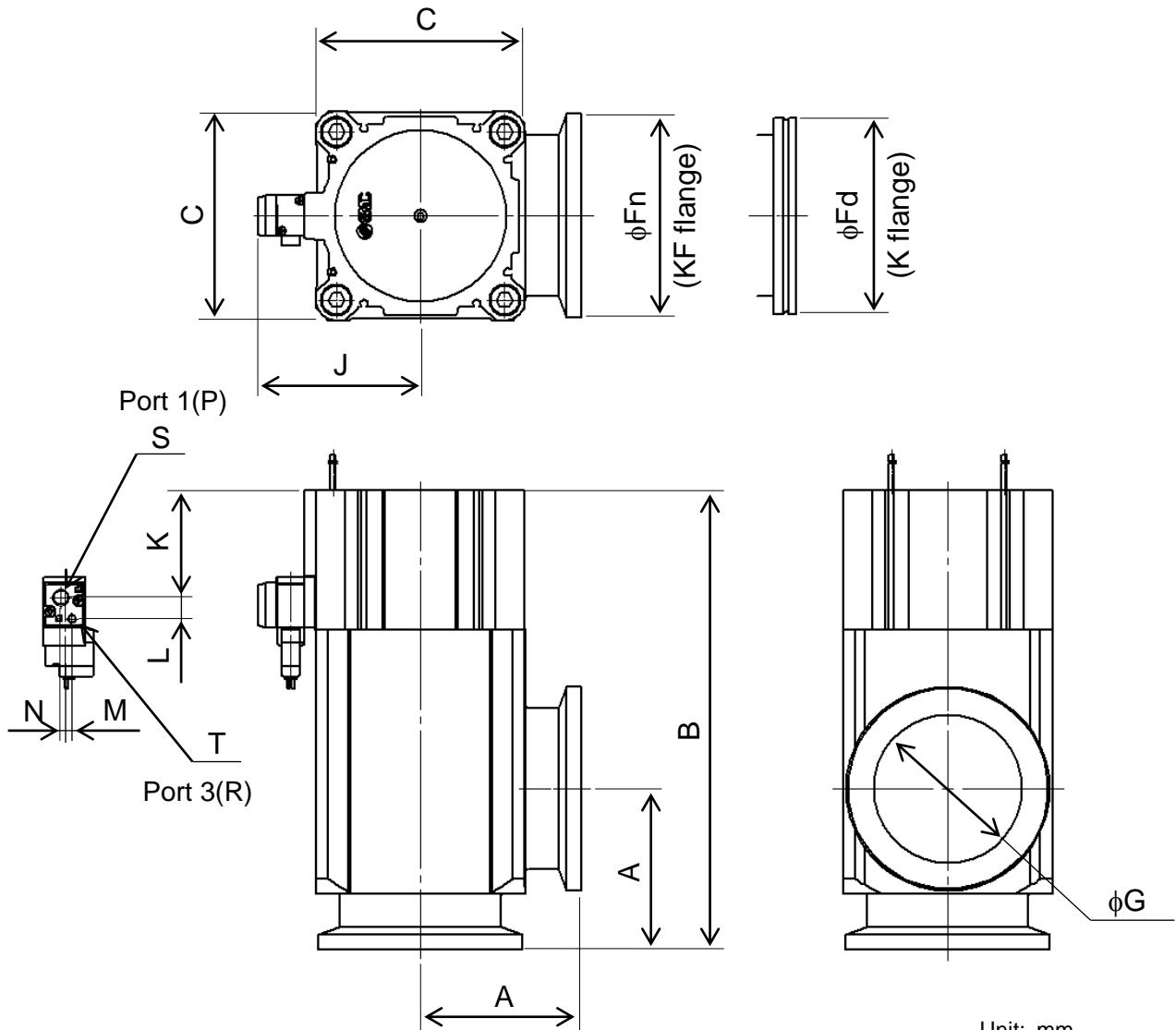

Unit: mm

Model	A	B	C	Fn	Fd	G	J
XLFV-16-2	40	108	38	30	-	17	41
XLFV-25-2	50	121	48	40	-	26	46
XLFV-40-2	65	171	66	55	-	41	54.5
XLFV-50-2	70	185	79	75	-	52	71
XLFV-63-2	88	212	100	87	95	70	80.5
XLFV-80-2	90	257	117	114	110	83	90.5

Model	K	L	M	N	S	T
XLFV-16-2	17.2	10.2	3.6	3.6	M5	M5
XLFV-25-2	21.4	10.2	3.6	3.6	M5	M5
XLFV-40-2	33.9	10.2	3.6	3.6	M5	M5
XLFV-50-2	35.3	12	4	2	Rc1/8	M5
XLFV-63-2	43.8	12	4	2	Rc1/8	M5
XLFV-80-2	59.8	12	4	2	Rc1/8	M5

6. Period and Scope of Warranty

The warranty period is 3 million cycles for sizes 16, 25 and 40, 2 million cycles for size 50, 63 and 80 (under SMC's endurance test conditions), 1 year in service or within 1.5 years after delivery, whichever comes first.

If the valve has been used outside of the specifications, or if a failure occurs as a result of mounting onto a machine or replacement of an assembly, seals, or etc. by the user, the warranty will not be applied.

Note) The endurance of the product will depend on the operating conditions (such as if the flow rate is large).

For any failure reported within the warranty period which is clearly our responsibility, the whole valve will be replaced. This guarantee does not apply to any damage incurred due to the failure of the valve.

Result of endurance test

(Using the circuit shown on the right)

The valve was opened and closed in an internal vacuum state at nominal (room) temperature and checked for internal and external leakage and proper operation.

We confirmed that the product satisfies the product specifications of 3 million cycles (for size 16, 25, 40) or 2 million cycles (for size 50, 63, 80).

The test was performed with FKM, the standard sealant material.

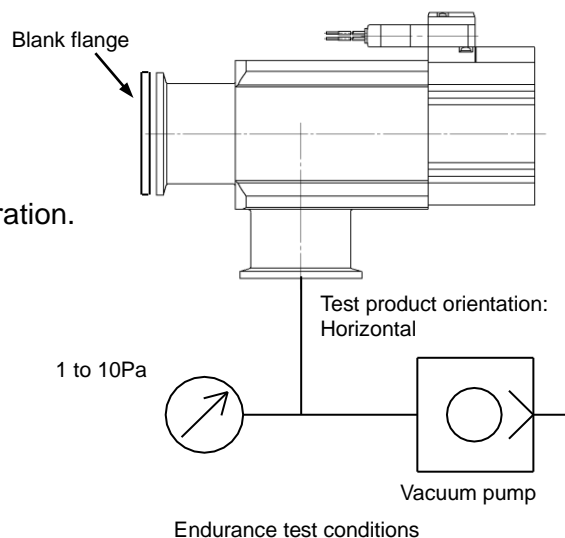

<Reference>

The pumping direction is not limited, but if the pumping creates a flow stream, the durability of the product could be impaired.

Therefore, the pumping direction shown on the right figure (shaft side pumping) is recommended. Also, the operating conditions should be checked prior to use, as this affects the life of the product.

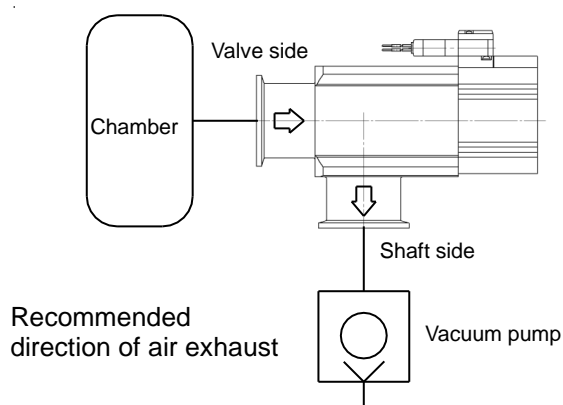

7. Parts Replacement Procedure

7-1. Precautions

Be sure to adhere to the instructions given in “2. Precautions 2”, when disassembling the product for maintenance. Along with the precautions listed in Chapter 2, the user should comply with those listed below.

Warning

- If it is expected that product materials may get stuck to the product, ensure safety is confirmed before handling. It is recommended that the user wear gloves and a mask.
- Pay attention to the handling of components in accordance with the procedures outlined, hereafter. Do not apply excessive force or impact. This may damage the product, as well as, decrease its performance and life expectancy.
- The cylinder portion of this product cannot be disassembled. When the cylinder portion or the bonnet assembly is damaged or is expected to have been damaged, replace the whole product or the bonnet assembly.
- Do not disassemble the parts that are not explained in this operation manual. This may decrease the performance and life expectancy of these parts. In addition, disassembly may cause danger.
- **Torque values specified in this manual must be followed.** Not adhering to these specifications, can result in damage to the product.

7-2. Disassembly Procedure

Step 1 Removal of bonnet assembly

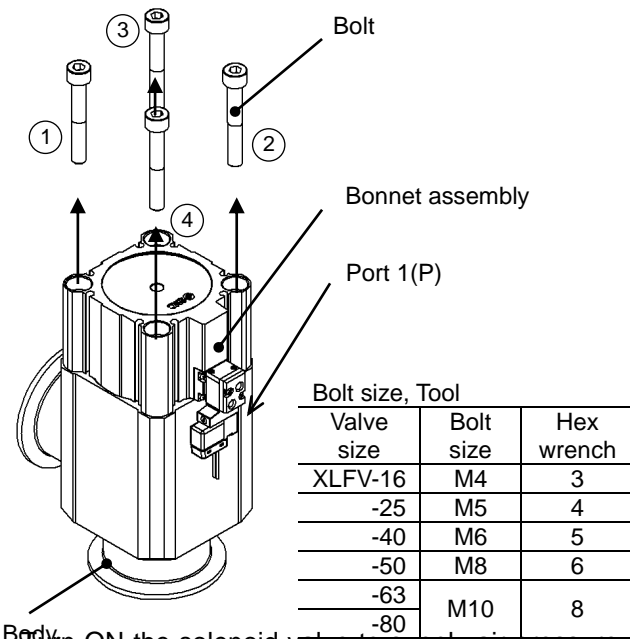

Turn ON the solenoid valve to supply air pressure of 0.4MPa (G) to the port 1(P). Loosen the bolts in numerical order to disassemble the body and the bonnet assembly. When it is difficult to remove the bonnet assembly due to adhesion of the external seal, pull the bonnet assembly straight up slowly without twisting the bonnet.

Step 2 Removal of valve seal 1

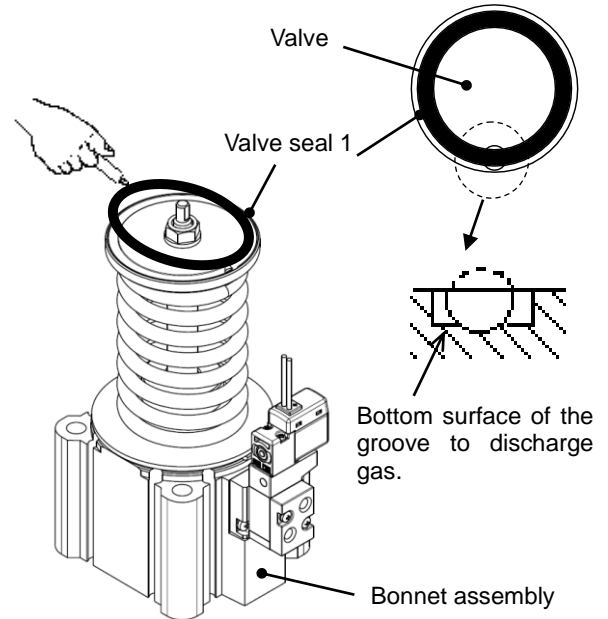

Remove the valve seal 1 from the seal mounting groove. Use a tool (e.g. which has a finger that is not longer than the depth from the bottom to the top of the groove). Use caution not to scratch the mounting groove surface of the seal.

Step 3 Removal of valve seal 2

Apply a spanner to the width across the flats of the shaft to prevent it from rotating.

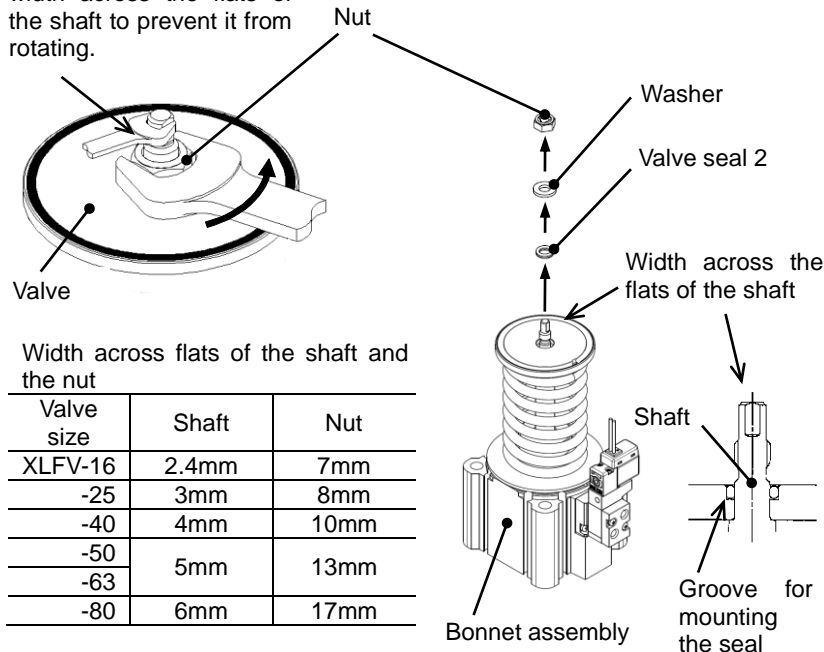

Apply a spanner to the width across the flats of the shaft of the bonnet assembly to hold the shaft, and remove the nut. Be careful not to damage the valve. Remove the washer and valve seal 2. Do not apply air pressure to the port 1(P) with the nut removed.

Step 4 Removal of external seal

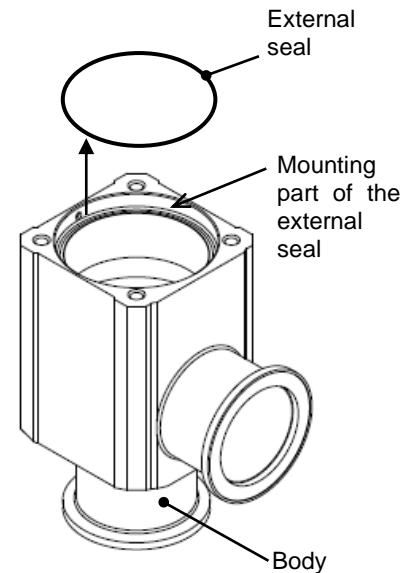

Remove the external seal from the body. (Take care not to damage the surface of the seal mounting groove.)

7-3. Assembly Procedure

Step 1 Preparation

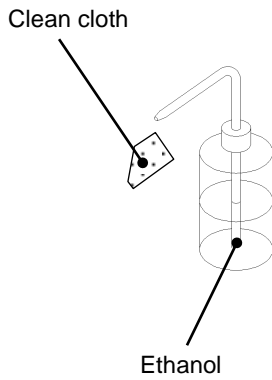

Assemble parts eliminating any dust or debris. Wipe off dust with a clean cloth soaked with ethanol. Blow parts with clean air if necessary. (Ensure there are no fibers or dust.)

Step 2 Reassembly of valve seal 2

Apply a spanner to the width across the flats of the shaft to prevent it from rotating.

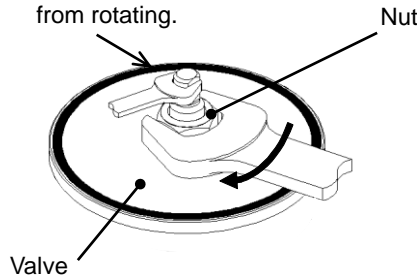

Width across flats of the shaft and the nut,
Tightening torque of nut (N·m)

Valve size	Shaft	Nut	Tightening torque
XLFV-16	2.4mm	7mm	0.9
-25	3mm	8mm	1.5
-40	4mm	10mm	2.5
-50	5mm	13mm	6.3
-63			
-80	6mm	17mm	14

Note)

For XLFV-16/25, mount the washer in the orientation that the groove of the washer faces to the valve seal 2.

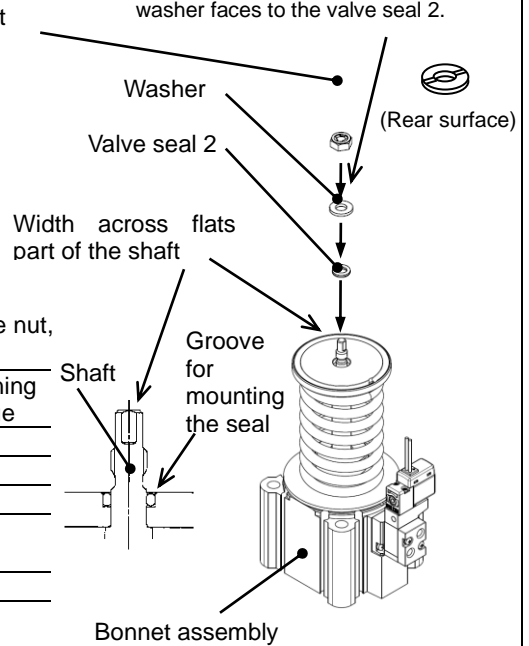

Mount the valve seal 2 and washer.

Securely mount the valve seal 2 into the seal mounting groove with caution not to damage the seal.

Mount the nut and hold the shaft at the width across the flats with a spanner, and tighten the nut with another spanner.

Secure the nut using the torque specified in the table.

Be sure to tighten the nut to the torque specified in the table as torques other than that specified may cause a loose nut or damage to the valve.

Step 3 Reassembly of valve seal 1 (No.1)

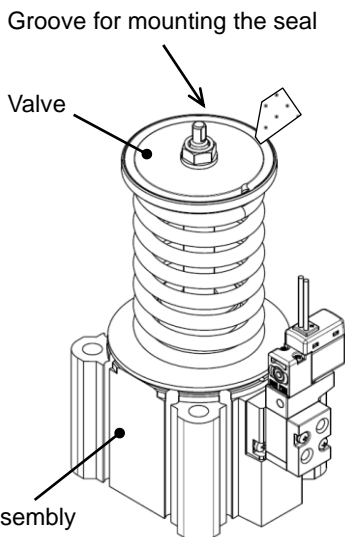

Eliminate any dust within groove for mounting the seal of the valve.

Step 4 Reassembly of valve seal 1 (No.2)

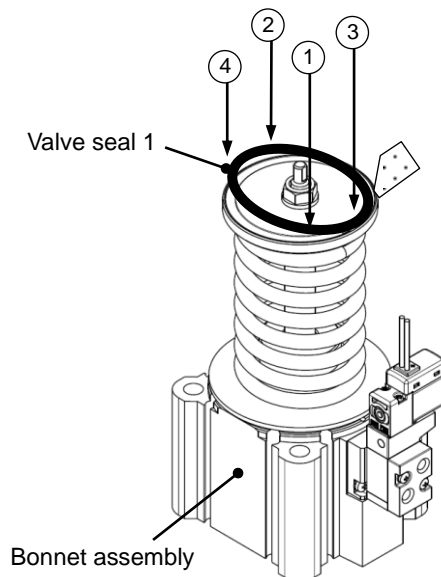

Wipe off any dust on the surface of the valve seal 1, then place the valve seal 1 in the seal mounting groove. Press the seal into the groove in numerical order (press diagonally) to fit the valve seal 1 into the groove. Do not twist the valve seal 1. Use dust-free gloves.

Step 5 Remount of external seal

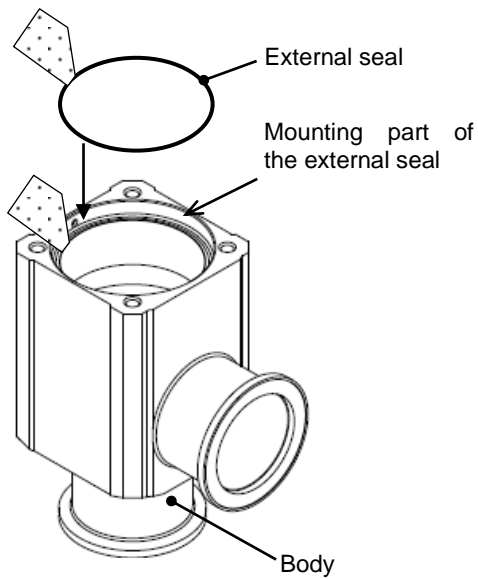

Wipe off any dust from the surface of the external seal and the mounting surface of the external seal on the body, then place the external seal in the mounting position on the body.

Step 6 Reassembly of bonnet assembly (No.1)

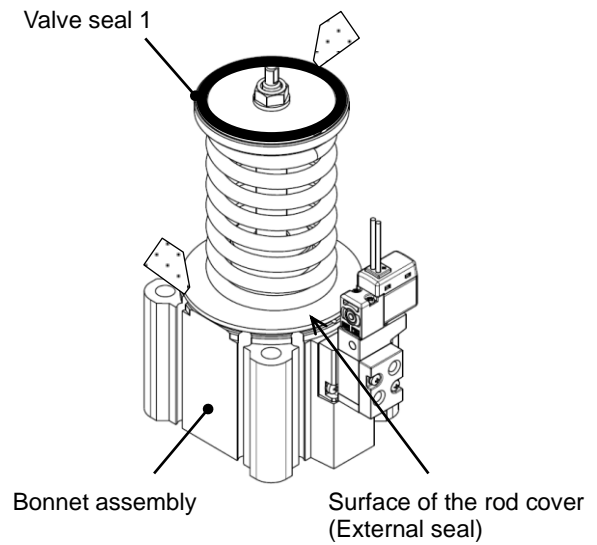

Wipe off any dust from the surfaces of the valve seal 1 and the rod cover.

Step 7 Reassembly of bonnet assembly (No.2)

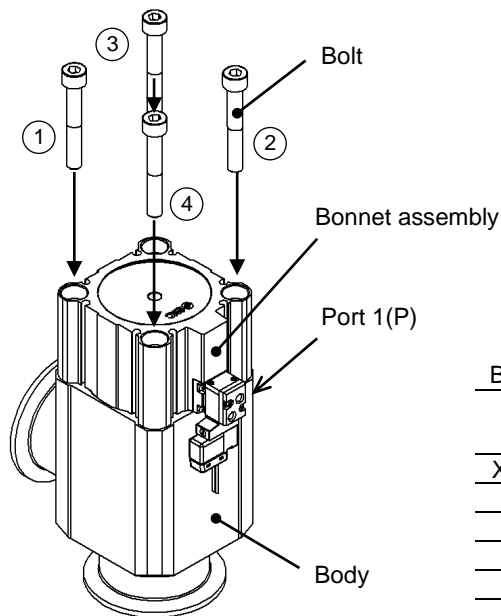

Bolt size, Tool, Tightening torque of bolt (N·m)

valve size	Bolt size	Hex wrench	Tightening torque
XLFV-16	M3	3	0.7
-25	M5	4	1.5
-40	M6	5	2.5
-50	M8	6	6.1
-63	M10	8	15
-80			

Turn ON the solenoid valve to supply air pressure of 0.4MPa (G) to the port 1(P). Tighten the bolts in numerical order to re-assemble the body with the bonnet assembly.

Manually tighten screws until the external seal is compressed. Perform final torqueing of the bolts in the same numerical order (diagonally).

7-4. Solenoid Valve Replacement Procedure

Step 1 Mounting the solenoid valve

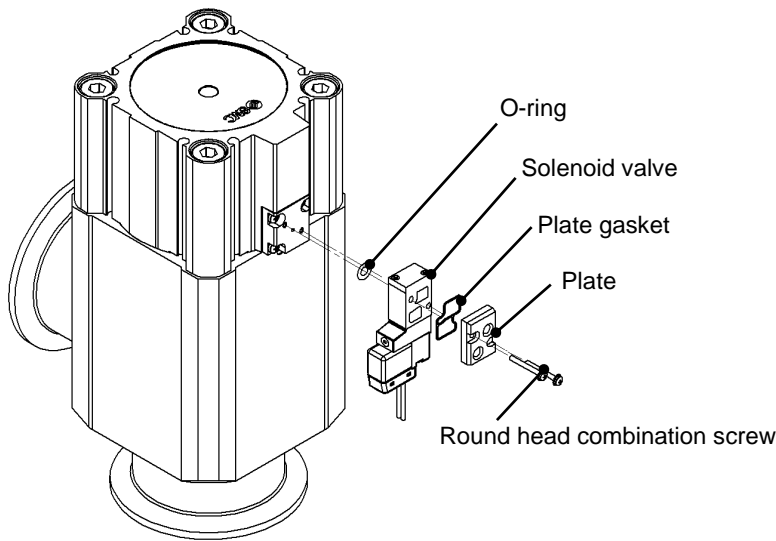

Note)

Tighten the mounting screws while holding the solenoid valve and plate securely. (Hold them using a monkey wrench).

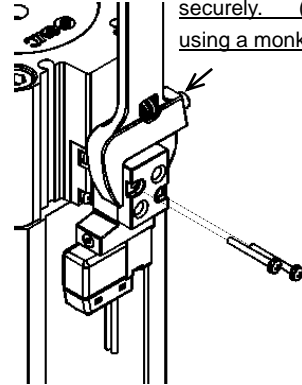

Set the parts in order of O-ring, solenoid valve, plate gasket, and plate. Tighten the screw to secure the solenoid valve.

Ensure that there the gasket is in place and there is not dust getting caught in parts.

Be sure to tighten the screw to the torque specified in the table. Otherwise, loose screw and air leakage can result.

The solenoid valve can be removed by removing the screws.

Screw size,

Tightening torque of screw (N·m)

Valve size	Screw size	Tightening torque
XLFV-16	M2	0.2
-25		
-40		
-50	M3	0.8
-63		
-80		

Revision history		
A	Front cover, back cover, safety precautions Correction	2024.08

1st printing: 2017.12

SMC Corporation

Tel: + 81 3 5207 8249 Fax: +81 3 5298 5362
URL <https://www.smcworld.com>

Note: Specifications are subject to change without prior notice and any obligation on the part of the manufacturer.
© SMC Corporation All Rights Reserved

XL-OMV0019-A