



Operation Manual

PRODUCT NAME

Two Hand Control Valve VR51

MODEL / Series / Product Number

VR51 Series

SMC Corporation

Contents

1. Safety Instructions	2
2. Application	9
3. Features	9
4. Specifications	9
5. How to Order	9
6. Basic Circuit Example	10
7. Construction	10
8. Piping Port Indication	11
9. Operation Timing and Output	11
10. Dimensions	12
11. Installation of Operation Buttons	13



Safety Instructions

These safety instructions are intended to prevent hazardous situations and/or equipment damage. These instructions indicate the level of potential hazard with the labels of “**Caution**,” “**Warning**” or “**Danger**.” They are all important notes for safety and must be followed in addition to International Standards (ISO/IEC)^{*1)}, and other safety regulations.

*1) ISO 4414: Pneumatic fluid power - General rules and safety requirements for systems and their components
ISO 4413: Hydraulic fluid power - General rules and safety requirements for systems and their components
IEC 60204-1: Safety of machinery - Electrical equipment of machines - Part 1: General requirements
ISO 10218-1: Robots and robotic devices - Safety requirements for industrial robots - Part 1: Robots
etc.



Danger

Danger indicates a hazard with a high level of risk which, if not avoided, will result in death or serious injury.



Warning

Warning indicates a hazard with a medium level of risk which, if not avoided, could result in death or serious injury.



Caution

Caution indicates a hazard with a low level of risk which, if not avoided, could result in minor or moderate injury.



Warning

1. The compatibility of the product is the responsibility of the person who designs the equipment or decides its specifications.

Since the product specified here is used under various operating conditions, its compatibility with specific equipment must be decided by the person who designs the equipment or decides its specifications based on necessary analysis and test results. The expected performance and safety assurance of the equipment will be the responsibility of the person who has determined its compatibility with the product. This person should also continuously review all specifications of the product referring to its latest catalog information, with a view to giving due consideration to any possibility of equipment failure when configuring the equipment.

2. Only personnel with appropriate training should operate machinery and equipment.

The product specified here may become unsafe if handled incorrectly. The assembly, operation and maintenance of machines or equipment including our products must be performed by an operator who is appropriately trained and experienced.

3. Do not service or attempt to remove product and machinery/equipment until safety is confirmed.

1. The inspection and maintenance of machinery/equipment should only be performed after measures to prevent falling or runaway of the driven objects have been confirmed.
2. When the product is to be removed, confirm that the safety measures as mentioned above are implemented and the power from any appropriate source is cut, and read and understand the specific product precautions of all relevant products carefully.
3. Before machinery/equipment is restarted, take measures to prevent unexpected operation and malfunction.

4. Our products cannot be used beyond their specifications. Our products are not developed, designed, and manufactured to be used under the following conditions or environments. Use under such conditions or environments is not covered.

1. Conditions and environments outside of the given specifications, or use outdoors or in a place exposed to direct sunlight.
2. Use for nuclear power, railways, aviation, space equipment, ships, vehicles, military application, equipment affecting human life, body, and property, fuel equipment, entertainment equipment, emergency shut-off circuits, press clutches, brake circuits, safety equipment, etc., and use for applications that do not conform to standard specifications such as catalogs and operation manuals.
3. Use for interlock circuits, except for use with double interlock such as installing a mechanical protection function in case of failure. Please periodically inspect the product to confirm that the product is operating properly.



Safety Instructions

Caution

We develop, design, and manufacture our products to be used for automatic control equipment, and provide them for peaceful use in manufacturing industries.

Use in non-manufacturing industries is not covered.

Products we manufacture and sell cannot be used for the purpose of transactions or certification specified in the Measurement Act.

The new Measurement Act prohibits use of any unit other than SI units in Japan.

Limited warranty and Disclaimer/Compliance Requirements

The product used is subject to the following “Limited warranty and Disclaimer” and “Compliance Requirements”.

Read and accept them before using the product.

Limited warranty and Disclaimer

1. The warranty period of the product is 1 year in service or 1.5 years after the product is delivered, whichever is first.*2)

Also, the product may have specified durability, running distance or replacement parts. Please consult your nearest sales branch.

2. For any failure or damage reported within the warranty period which is clearly our responsibility, a replacement product or necessary parts will be provided.

This limited warranty applies only to our product independently, and not to any other damage incurred due to the failure of the product.

3. Prior to using SMC products, please read and understand the warranty terms and disclaimers noted in the specified catalog for the particular products.

***2) Vacuum pads are excluded from this 1 year warranty.**

A vacuum pad is a consumable part, so it is warranted for a year after it is delivered.

Also, even within the warranty period, the wear of a product due to the use of the vacuum pad or failure due to the deterioration of rubber material are not covered by the limited warranty

Compliance Requirements

1. The use of SMC products with production equipment for the manufacture of weapons of mass destruction (WMD) or any other weapon is strictly prohibited.

2. The exports of SMC products or technology from one country to another are governed by the relevant security laws and regulations of the countries involved in the transaction. Prior to the shipment of a SMC product to another country, assure that all local rules governing that export are known and followed.

Design

Warning

1. Actuator drive

When an actuator, such as a cylinder, is to be driven using a valve, take appropriate measures to prevent potential danger caused by actuator operation.

2. Maintenance space

The installation should allow sufficient space for maintenance activities.

3. Ventilation

When a valve is used inside a sealed control panel, etc., provide ventilation to prevent a pressure increase caused by exhausted air inside the control panel or temperature rise caused by the heat generated by the valve.

4. Elimination of significant difference in piping length on VR51's inlet side

Make the piping work so that the piping lengths (L1 and L2) to the P1 and P2 sides to be connected to the inlet side of the VR51 have no significant difference. Additionally, make the piping work so that the piping lengths (L1' and L2') to two mechanical valves from the air supply also have no significant difference. If the difference between the piping lengths is significant, a time lag occurs during pressure increase of P1 and P2. This may cause the output to malfunction even when operated at the same time.

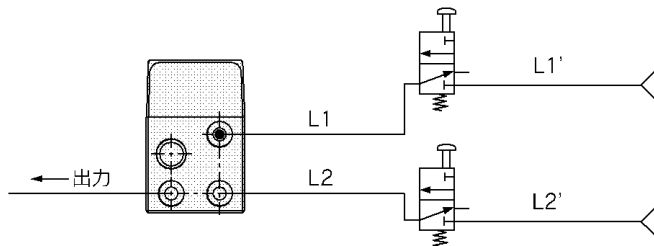

Selection

Warning

1. Confirm the specification.

The products presented in this catalog are designed only for use in compressed air systems. Do not operate at pressures or temperatures, etc., beyond the range of specifications, as this can cause damage or malfunction. (Refer to specifications.)

Contact SMC when using a fluid other than compressed air.

2. Using in low temperature

In the case of using in low temperature, take measures not to freeze the drainage or moisture.

Mounting

Warning

1. If air leakage increases or equipment does not operate properly, stop operation.

Check mounting conditions when air and power supplies are connected. Initial function and leakage tests should be performed after installation.

2. Operation manual

Mount and operate the product after reading the manual carefully and understanding its contents.

Also keep the manual where it can be referred to as necessary.

3. Painting and coating

Warnings or specifications printed or pasted on the product should not be erased, removed or covered up. Consult with SMC if paint is to be applied to resinous parts, as this may have an adverse effect due to the paint solvent.

Mounting



Caution

1. Tubing, with the exception of coiled tubing, requires stationary installation. Do not use standard tubing (non-coiled) in applications where tubing is required to travel within a cable carrier. Tubing that travels may sustain abrasion, extension, or severance due to tensile force, or may result in removal of tubing from fitting. Use caution prior to use for proper application.
2. Transportation, installation, piping, operation, manipulation, maintenance, and inspection should be conducted by a knowledgeable and experienced person.
Otherwise, electric shock, injuries, fire, etc. may occur.
3. Do not modify the product because this will likely cause injuries and damage.
4. Do not wipe the product with a cloth containing chemicals

Piping



Caution

1. Preparation before piping

Before piping is connected, it should be thoroughly blown out with air (flushing) or washed to remove chips, cutting oil and other debris from inside the pipe.

2. When piping on the product

In the case of connecting piping to the product, consult the operation manual and use caution to avoid making a mistake with the supply port, etc.

3. Connect tubing with some extra length to prevent torsion, stretching, or a moment load from being applied to the fittings and tubing. Damage to the fittings or flattening, as well as bursting or releasing of the tubing may occur, if the above is not followed.

4. The tubing connected to the product should be more than its minimum bending radius. If the minimum bending radius is tighter than that it should be, bending or flating of the tubing may occur.

The minimum bending radius is measured as following in accordance with JIS B 8381-1995. JIS specifies the tubing deformation ratio measured at the minimum bending ratio to be 25% or less.

* Except for the TU, TIUB, TUH, TRBU, TAU and TUS series

Tube deformation ratio at the minimum bending radius is obtained through the following formula, based on tubing diameter and mandrel diameter by wrapping the same radius mandrel tube.

$$\eta = \left(1 - \frac{L-D}{2d} \right) \times 100$$

Here, η : Deformation ratio (%)
 d : Tube diameter (mm)
 L : Measured length (mm)
 D : Mandrel diameter (mm)
 (Twice against the minimum bending radius)

Test temperature: $20 \pm 5^\circ\text{C}$

Relative humidity: $65 \pm 5\%$

Tube deformation ratio at the minimum bending radius

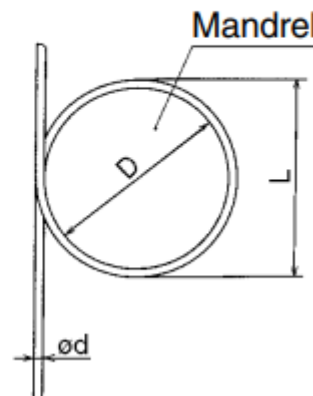

Handling of One-touch Fittings



Caution

1. Tube insertion and removal from One-touch fittings

1) Attaching of tubing

- a. Cut the tube perpendicularly, being careful not to damage the outside surface. Use SMC tube cutter "TK-1", "TK-2" or "TK-3". Do not cut the tube with pliers, nippers, scissors, etc., otherwise, the tube will be deformed and troubles may result.
- b. Outside diameter of polyurethane tubing is swelled by applying internal pressure. As such, it may be that the tubing cannot be re-inserted into One-touch fittings. Make sure to confirm the tubing outside diameter, and when the accuracy of the outside diameter is more than + 0.15, insert into One-touch fitting again, not cutting the tubing to use it. When tubing is re-inserted into One-touch fitting, make sure to confirm that the tubing was able to go through the release bush smoothly.
- c. Grasp the tube, slowly push it into the One-touch fittings until it comes to a stop.
- d. Pull the tubing back gently to make sure it has a positive seal. Insufficient installation may cause air to leak or the tube to release.

2) Removal of tubing

- a. Sufficiently depress the release bushing and tubing, making sure to apply even pressure around the release bushing.
- b. Pull out the tubing while depressing the release bushing so that it does not pop out. If the release bushing is not depressed sufficiently, there will be an increased bite on the tubing and it will become more difficult to pull out.
- c. When the removed tubing is reused, first cut off the section of the tubing which has been clamped. Reusing the clamped portion of the tubing can cause problems such as leakage, difficulties in removal, etc.

3) Connecting fittings with metal rods

After connecting a fitting with a metal rod (KC series, etc.) to a One-touch fitting, do not use in combination with tubes, resin plugs, or reducers. Doing so may result in the fittings coming loose.

- ##### 4) When mounting tubes, resin plugs, metal rods etc., do not press the release button. Also, do not press the release button unnecessarily before mounting them. This may cause those parts to come off.

Precautions on Other Tubing Brands



Caution

1. When using tubing brands other than SMC, confirm that the tubing outside diameter tolerances satisfy the following specifications.

- 1) Nylon tubing within ± 0.1 mm
- 2) Soft nylon tubing within ± 0.1 mm
- 3) Polyurethane tubing within +0.15 mm
within -0.2 mm

Do not use tubing if the outside diameter tolerance is not satisfied. It may not be possible to connect the tubing, or leakage or disconnection may occur after connection.

Lubrication



Caution

1. Lubrication

- 1) The valve has been lubricated for life at the manufacturer, and does not require any further lubrication.
- 2) If a lubrication is applied in the system, use turbine oil Class 1 (no additive), ISO VG32. However, once lubrication is applied it must be continued, as loss of the original lubricant may lead to malfunction.

Air Supply



Warning

1. Use clean air.

Do not use compressed air which contains chemicals, synthetic oils containing organic solvents, salts or corrosive gases, etc., as this can cause damage or malfunction.



Caution

1. Install air filters. Install air filters close to valves at their upstream side. A filtration degree of 5 µm or less should be selected.
2. Install an air dryer, after cooler or Drain Catch, etc. Air that includes excessive drainage may cause malfunction of valves and other pneumatic equipment. To prevent this, install an air dryer, after-cooler or water separator, etc.
3. If excessive carbon powder is seen, install a mist separator on the upstream side of the valve. If excessive carbon dust is generated by the compressor, it may adhere to the inside of valves and cause malfunction.
Refer to SMC's "Air Cleaning Equipment" catalog for compressed air quality.

Operating Environment



Warning

1. Do not use in atmospheres where the valve is in direct contact with corrosive gases, chemicals, salt water, water or steam.
2. Do not use in locations subject to vibration or impact. Confirm the specifications in the main section of the catalog.
3. Use a protective cover, etc., to shield valves from direct sunlight.
4. Shield valves from radiated heat generated by nearby heat sources.
5. Employ suitable protective measures in locations where there is contact with oil or welding spatter, etc.



Caution

1. Avoid using in a place where there is splashing oil, coolant, or water. In addition, avoid using where dust may adhere to it.

Maintenance



Warning

1. Perform maintenance procedures as shown in the operation manual.

If handled improperly, malfunction or damage of machinery or equipment may occur.

2. Removal of equipment and supply/exhaust of compressed air

When equipment is serviced, first confirm that measures are in place to prevent dropping of work pieces and run-away of equipment, etc. Then cut the supply pressure and power, and exhaust all compressed air from the system using its residual pressure release function. When the equipment is to be started again after remounting or replacement, first confirm that measures are in place to prevent lurching of actuators, etc., and then confirm that the equipment is operating normally.

3. Be sure to perform an inspection before operating for the first time as well as before operating for the first time after a long period of non-operation to make sure that the VR51 operates properly.

Failure to observe this precaution could lead to unsafe operation, such as unintended operation or malfunction.

4. During regular maintenance, check for the following and replace any components as necessary

- a) There are no scratches, corrosion, loose screws, or other visible damage on the valve body.
- b) There is no damage to the One-touch fittings.
- c) There is no damage to tubes, including kinks or flattening.
- d) There is no hardening, deteriorating, or softening of tubes.
- e) There is no air leakage.
- f) The air pressure is in the 0.25 MPa to 1 MPa range.
- g) There is output from the A port of the VR51 when the 2 control devices installed on the IN side are operated simultaneously.
- h) There is no output from the A port of the VR51 when 1 of the 2 control devices installed on the IN side is operated.
- i) There is no output from the A port of the VR51 when the 2 control devices installed on the IN side are operated more than 0.5 seconds apart.
- j) When the A port of the VR51 is in a state of output, if the operation of one of the control devices is stopped, the output from the A port ceases.

5. Do not repair the fittings or patch the tubing for reuse.

6. Remove drainage from air filters regularly.

Caution on Preparing the Buttons for Manipulation



Warning

1. When arranging the operation buttons, be sure to design and arrange according to clause 7 “Prevention of accidental actuation and of defeat” of CE/UKCA MARKED EN ISO13851:2019: “Safety of machinery — Two-hand control devices — Principles for design and selection.” If the operation buttons are incorrectly arranged, unexpected operation or motion may occur, resulting in an inability to maintain the safety of the device.

Pneumatic Pressure



Warning

1. Do not use the product with a pressure of under 0.25 MPa. The time lag for operating the VR51 is different depending on the operating pressure.
The higher the operating pressure, the shorter the time lag, and vice versa. If used under 0.25 MPa, an output will be available; however, safety is not likely to be maintained, even though the time lag may exceed 0.5 seconds.
2. Supply the same pressure to P1 and P2.
If the difference in supply pressure exceeds 0.1 MPa, the output may malfunction even when operated at the same time.

2. Application

The VR51 is a valve designed to be operated by both hands simultaneously at the startup of an actuator through button operation to ensure the safety of the worker.

As the worker uses both hands in operation of the start button, it is possible to prevent accidents including pinching of hands in a work process.

3. Features

- 1) If the difference in input timings (time of devices to be operated) between two air signals is 0.5 seconds or longer, there will not be an output.
- 2) If one air signal input is lost while VR51 is performing output, the output will be stopped.
- 3) To resume the output, it is necessary to simultaneously input two air signals again.
- 4) VR51 is compliant with Category 1, Type III A of the European Standards [Safety of machinery -- Two-hand control devices -- Principles for design and selection] (CE/UKCA MARKED EN ISO13851:2019).

4. Specifications

Fluid		Air	
Operating pressure		0.25~1MPa	
Proof pressure		1.5MPa	
Ambient and fluid temperature		-5~60°C (with no freezing)	
Flow rate characteristics		C[dm ³ /(s·bar)]	Cv
P→A		0.3	-
A→R		1.0	0.25
Port size	Metric size	Φ6	
	Inch size	Φ1/4	
Applicable tubing material Note)		Nylon, Soft nylon, Polyurethane, Flame resistant (FR) soft nylon, FR double layer, FR double layer polyurethane	
Weight		340g	
Accessory	Silencer	Part No. : AN101-01	
Option	Bracket	Part No. : VR51B	
Standard		EN ISO13851: 2019 Class: Type III A	

Note) In the case of using soft nylon or polyurethane tubing, use caution when the maximum operating pressure of the tubing is used.

5. How to Order

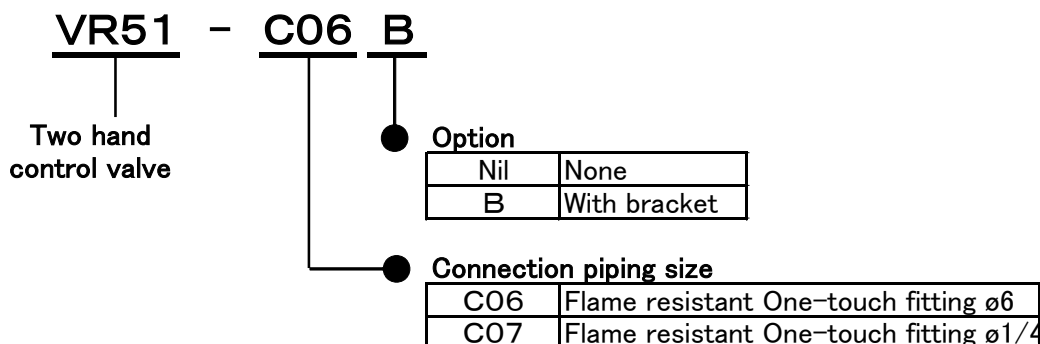

6. Example of a Basic Circuit Diagram

The basic circuit for use of VR51 is shown below.
Each value in parentheses indicates a port number of VR51-C07.

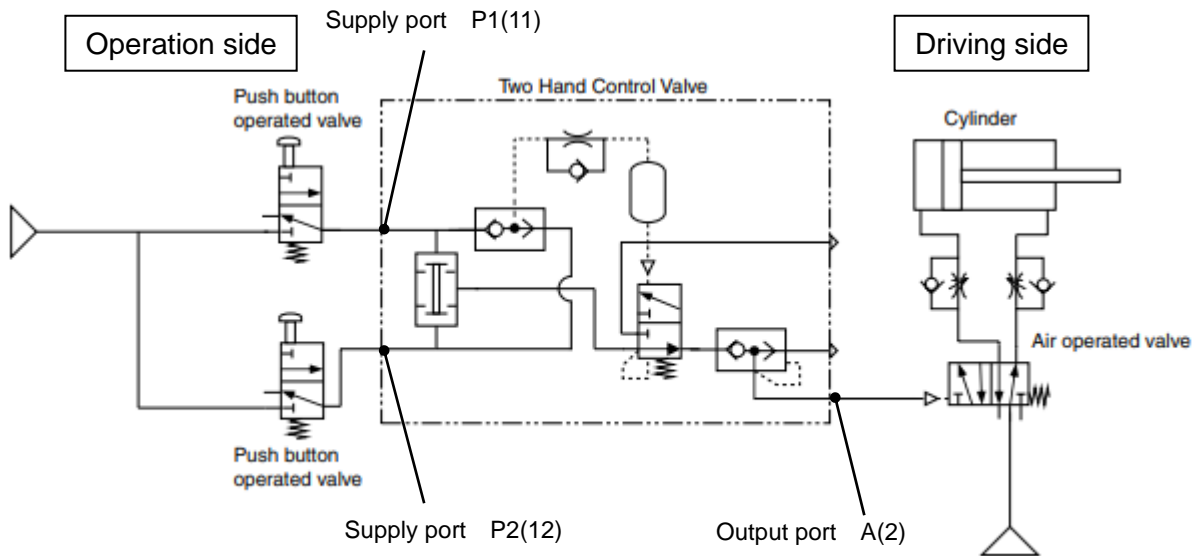

7. Construction

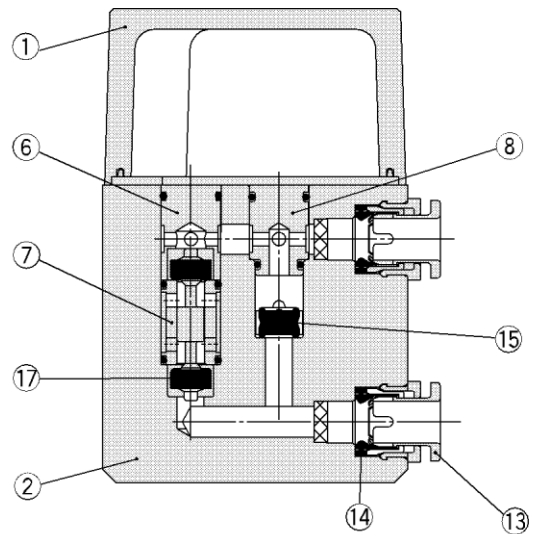
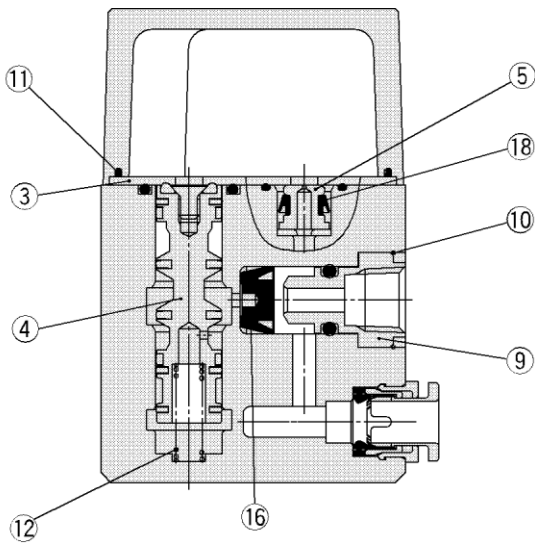

Component Parts

No.	Description	Material	Note
1	Cover	Aluminum die-cast	Gray
2	Body	Aluminum die-cast	White
3	Plate	Rolled steel	Nickel plated
4	Spool valve	Aluminum alloy	
5	Orifice	Brass	Electroless nickel plated
6	Valve seat	Aluminum alloy	
7	Valve guide B	Aluminum alloy	
8	Valve guide A	Aluminum alloy	
9	Guide	Brass	Electroless nickel plated

No.	Description	Material	Note
10	Clip	Stainless steel	
11	Gasket	H-NBR	
12	Spring	Stainless steel	
13	Cassette assembly		
14	Seal	NBR	
15	Valve	H-NBR	
16	Valve	NBR	
17	Valve	H-NBR	
18	U-shaped seal	H-NBR	

8. Piping Port Indication

Each value in parentheses indicates a port number for VR51-C07

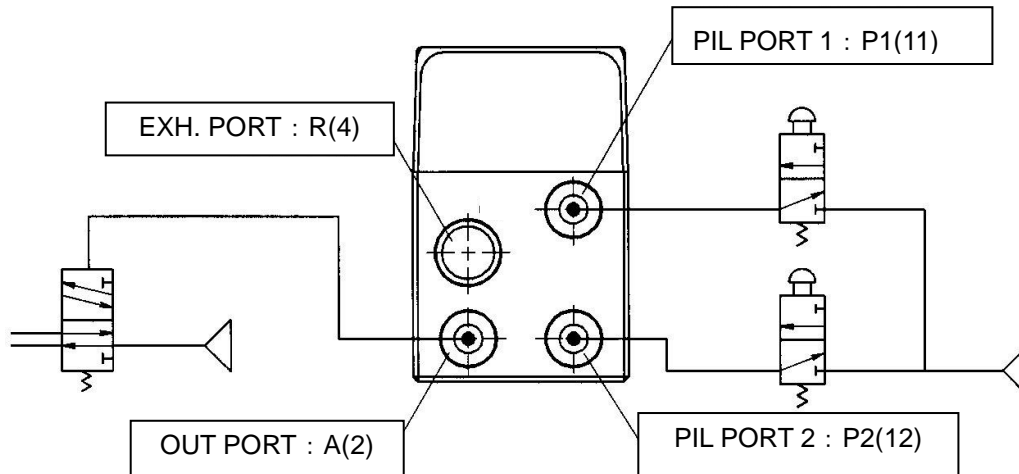

9. Operation Timing and Output

If the delay between the two input air signals is 0.5 seconds or longer, there will be no output.

The time delay with which output from VR51 is possible differs depending on the operating pressure.

The higher the operating pressure, the shorter the time delay, and vice versa .

The time delay with which output is possible is shown below. As it differs depending on the piping conditions and the device to be connected, use this graph only as a guide.

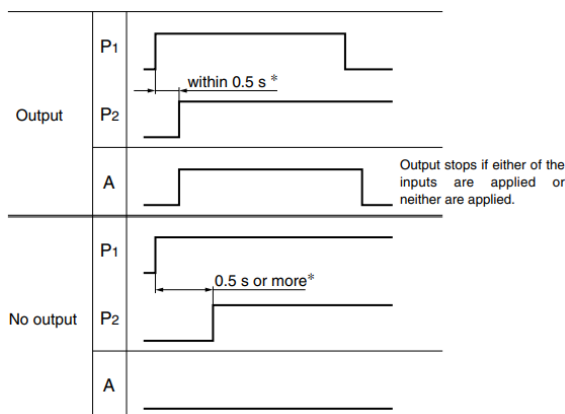

Time difference between inputs with which output from VR51 is possible

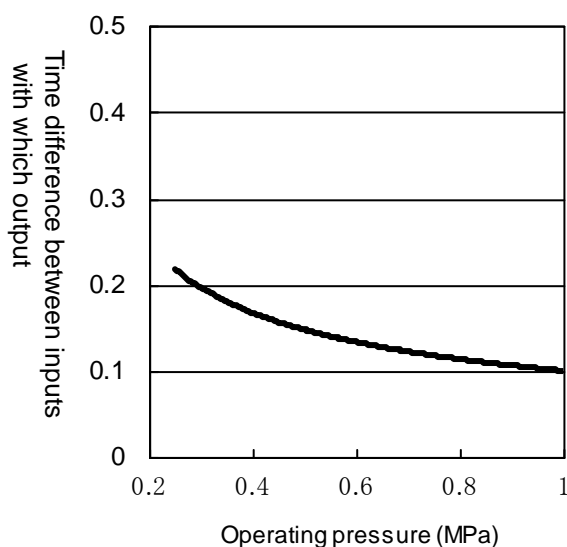

[Conditions]

1. Piping: Tube with an inside diameter of 4 mm such as T0604
2. Piping length: length on primary side of 1 m length on secondary side of 3 m
3. Device to be connected: a single air operated valve

10. Dimensions

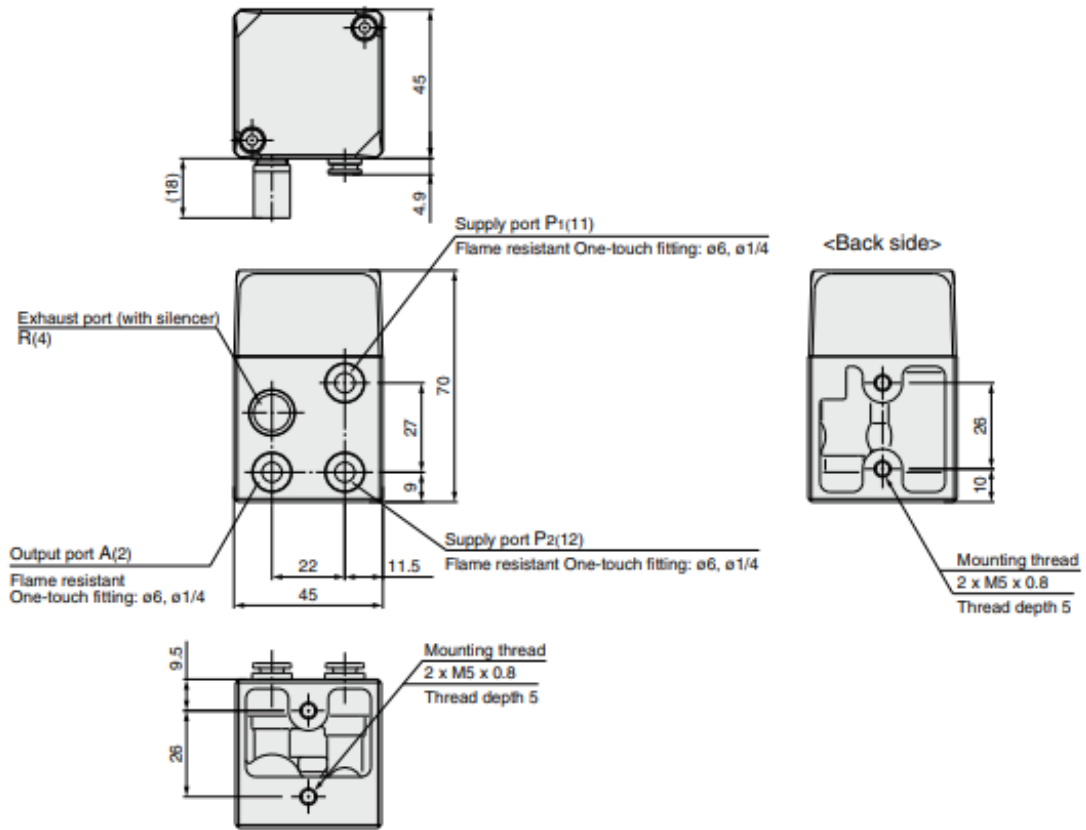

Bracket mounting dimensions

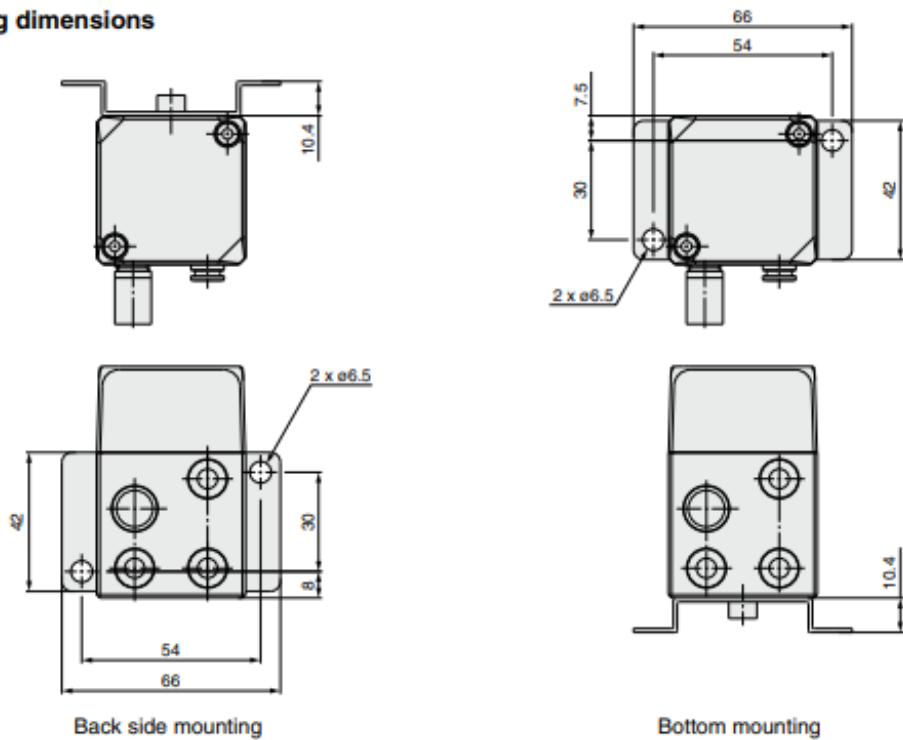

11. Installation of Operation Buttons

When installing operation buttons, design and arrange buttons in accordance with Section 7 “Prevention of accidental actuation and of defeat” of the international standards [Safety of machinery -- Two-hand control devices -- Principles for design and selection] (CE/UKCA MARKED EN ISO13851:2019).

- 1) Arrange the buttons so that it is not possible to operate both buttons at the same time only with a single hand.
- 2) Arrange the buttons so that it is not possible to operate both buttons at the same time only with a single arm.
- 3) Arrange the buttons so that it is not possible to operate both buttons at the same time by using any forearm (including both forearms) or any elbow (including both elbows).
- 4) Arrange the buttons so that it is not possible to operate both buttons at the same time by using a single hand and any part of body (such as knee and hip).

[Installation example]

- 1) Keep a sufficient distance between the buttons.

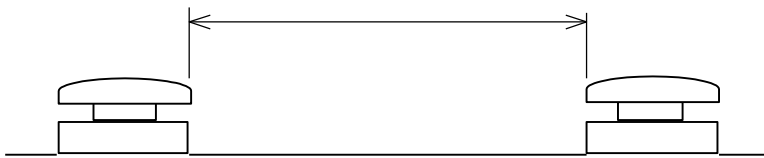

- 2) Install a shielding object between the buttons.



- 3) Install a cover on each button.



Revision history	
A: Updated standards and formats.	Oct/18/2023
B: Updated formats.	Mar/26/2024

SMC Corporation

Tel: + 81 3 5207 8249 Fax: +81 3 5298 5362

URL <https://www.smcworld.com>

Note: Specifications are subject to change without prior notice and any obligation on the part of the manufacturer.
© SMC Corporation All Rights Reserved