



Operation Manual

PRODUCT NAME

3-Port Solenoid Valve Modular Type/
Residual Pressure Relief Valve

MODEL/ Series

VP346E / VP546E / VP746E / VP946E Series

SMC Corporation

Contents

Contents	1
Safety Instructions	2,3
Design / Selection	4,5
Mounting	5
Piping	5
Wiring	5
Lubrication	5
Air Supply	5,6
Operating Environment	6
Maintenance	6
Specific Product Precautions	7,8,9
Trouble shooting	10,11



Safety Instructions

These safety instructions are intended to prevent hazardous situations and/or equipment damage. These instructions indicate the level of potential hazard with the labels of “**Caution**,” “**Warning**” or “**Danger**.” They are all important notes for safety and must be followed in addition to International Standards (ISO/IEC)*1), and other safety regulations.

*1) ISO 4414: Pneumatic fluid power - General rules and safety requirements for systems and their components
ISO 4413: Hydraulic fluid power - General rules and safety requirements for systems and their components
IEC 60204-1: Safety of machinery - Electrical equipment of machines - Part 1: General requirements
ISO 10218-1: Robots and robotic devices - Safety requirements for industrial robots - Part 1: Robots
etc.



Danger

Danger indicates a hazard with a high level of risk which, if not avoided, will result in death or serious injury.



Warning

Warning indicates a hazard with a medium level of risk which, if not avoided, could result in death or serious injury.



Caution

Caution indicates a hazard with a low level of risk which, if not avoided, could result in minor or moderate injury.

Warning

1. The compatibility of the product is the responsibility of the person who designs the equipment or decides its specifications.

Since the product specified here is used under various operating conditions, its compatibility with specific equipment must be decided by the person who designs the equipment or decides its specifications based on necessary analysis and test results. The expected performance and safety assurance of the equipment will be the responsibility of the person who has determined its compatibility with the product. This person should also continuously review all specifications of the product referring to its latest catalog information, with a view to giving due consideration to any possibility of equipment failure when configuring the equipment.

2. Only personnel with appropriate training should operate machinery and equipment.

The product specified here may become unsafe if handled incorrectly. The assembly, operation and maintenance of machines or equipment including our products must be performed by an operator who is appropriately trained and experienced.

3. Do not service or attempt to remove product and machinery/equipment until safety is confirmed.

1. The inspection and maintenance of machinery/equipment should only be performed after measures to prevent falling or runaway of the driven objects have been confirmed.
2. When the product is to be removed, confirm that the safety measures as mentioned above are implemented and the power from any appropriate source is cut, and read and understand the specific product precautions of all relevant products carefully.
3. Before machinery/equipment is restarted, take measures to prevent unexpected operation and malfunction.

4. SMC products cannot be used beyond their specifications. They are not developed, designed, and manufactured to be used under the following conditions or environments. Use under such conditions or environments is not allowed.

1. Conditions and environments outside of the given specifications, or use outdoors or in a place exposed to direct sunlight.
2. Use for nuclear power, railways, aviation, space equipment, ships, vehicles, military application, equipment affecting human life, body, and property, combustion equipment, entertainment equipment, emergency shut-off circuits, press clutches, brake circuits, safety equipment, etc., and use for applications that do not conform to standard specifications such as catalogs and operation manuals.
3. Use for interlock circuits, except for use with double interlock such as installing a mechanical protection function in case of failure. Please periodically inspect the product to confirm that the product is operating properly.



Safety Instructions

Caution

SMC develops, designs, and manufactures products to be used for automatic control equipment, and provides them for peaceful use in manufacturing industries.

Use in non-manufacturing industries is not allowed.

Products SMC manufactures and sells cannot be used for the purpose of transactions or certification specified in the Measurement Act of each country.

The new Measurement Act prohibits use of any unit other than SI units in Japan.

Limited warranty and Disclaimer/Compliance Requirements

The product used is subject to the following “Limited warranty and Disclaimer” and “Compliance Requirements”. Read and accept them before using the product.

Limited warranty and Disclaimer

1. The warranty period of the product is 1 year in service or 1.5 years after the product is delivered, whichever is first.*2)
Also, the product may have specified durability, running distance or replacement parts. Please consult your nearest sales branch.
2. For any failure or damage reported within the warranty period which is clearly our responsibility, a replacement product or necessary parts will be provided.
This limited warranty applies only to our product independently, and not to any other damage incurred due to the failure of the product.
3. Prior to using SMC products, please read and understand the warranty terms and disclaimers noted in the specified catalog for the particular products.

***2) Vacuum pads are excluded from this 1 year warranty.**

A vacuum pad is a consumable part, so it is warranted for a year after it is delivered.

Also, even within the warranty period, the wear of a product due to the use of the vacuum pad or failure due to the deterioration of rubber material are not covered by the limited warranty

Compliance Requirements

1. The use of SMC products with production equipment for the manufacture of weapons of mass destruction (WMD) or any other weapon is strictly prohibited.
2. The exports of SMC products or technology from one country to another are governed by the relevant security laws and regulations of the countries involved in the transaction. Prior to the shipment of a SMC product to another country, assure that all local rules governing that export are known and followed.



3/4/5-Port Solenoid Valves Precautions 1

Be sure to read this before handling products.

Design/Selection

⚠ Warning

1. Confirm the specifications.

Products represented in this instruction manual are designed only for use in compressed air systems. Do not operate at pressures or temperatures, etc., beyond the range of specifications, as this can cause damage or malfunction.

We do not guarantee against any damage if the product is used outside of the specification range.

2. Actuator drive

When an actuator, such as a cylinder, is to be driven using a valve, take appropriate measures (such as the installation of a cover or the restricting of access to the product) to prevent potential danger caused by actuator operation.

3. Holding pressure

Since valves are subject to air leakage, they cannot be used for applications such as holding pressure in a pressure vessel.

4. Not suitable for use as an emergency shutoff valve, etc.

The valves listed in this catalog are not designed for safety applications such as an emergency shutoff valve. If the valves are used in such applications, additional safety measures should be adopted.

5. Release of residual pressure

For maintenance and inspection purposes install a system for releasing residual pressure.

6. Ventilation

Provide ventilation when using a valve in a confined area, such as in a closed control panel. For example, install a ventilation opening, etc., in order to prevent pressure from increasing inside of the confined area and to release the heat generated by the valve.

7. Do not disassemble the product or make any modifications, including additional machining.

Doing so may cause human injury and/or an accident.

8. Resumption after a long period of holding time

When resuming operation after a long period of holding time, there are cases in which, regardless of whether the product is in an ON or OFF state, there is a delay in the initial response time due to adhesion. Conducting several cycles of running-in operation will solve this problem. Please consider implementing this before resumption.

⚠ Caution

1. Leakage voltage

Take note that the leakage voltage will increase when a resistor is used in parallel with a switching element or when a C-R circuit (surge voltage suppressor) is used for protecting a switching device because of the leakage voltage passing through the C-R circuit. The suppressor residual leakage voltage should be 3% or less of rated voltage.

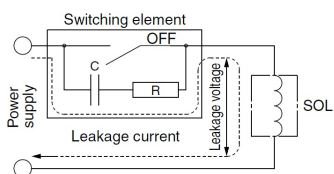

2. Surge voltage suppressor

1) The surge voltage suppressor built into the valve is intended to protect the output contacts so that the surge generated inside the valve does not adversely affect the output contacts. Therefore, if an overvoltage or overcurrent is received from an external peripheral device, the surge voltage protection element inside the valve is overloaded, causing the element to break. In the worst case, the breakage causes the electric circuit to enter short-circuit status. If energizing continues while in this state, a large current flows. This may cause secondary damage to the output circuit, external peripheral device, or valve, and may also cause a fire. So, take appropriate protective measures such as the installation of an overcurrent protection circuit in the power supply or a drive circuit to maintain a sufficient level of safety.

2) If a surge protection circuit contains nonstandard diodes, such as Zener diodes or varistor, a residual voltage that is in proportion to the protective circuit and the rated voltage will remain. Therefore, take into consideration the surge voltage protection of the controller.

In the case of diodes, the residual voltage is approximately 1V.

3. Surge voltage intrusion

With non-polar type valves, at times of sudden interruption of the loading power supply, such as emergency shutdown, surge voltage intrusion may be generated from loading equipment with a large capacity (power consumption), and a valve in a de-energized state may switch over (see Figure 1).

When installing a breaker circuit for the loading power supply, consider using a solenoid valve with polarity (with polarity protection diode), or install a surge absorption diode between the loading equipment COM line and the output equipment COM line (see Figure 2).

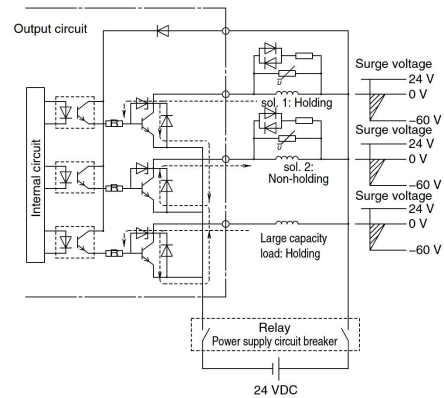

Figure 1. Surge intrusion circuit example (NPN outlet example)

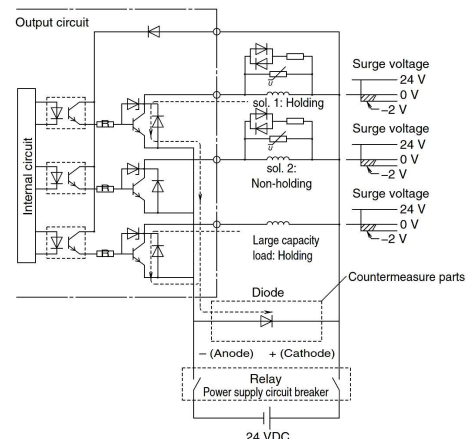

Figure 2. Surge intrusion countermeasure example (NPN outlet example)



3/4/5-Port Solenoid Valves Precautions 2

Be sure to read this before handling products.

Design/Selection

⚠ Caution

4. Operation in low temperature conditions

It is possible to operate a valve in extreme temperatures, as low as -10°C . Take appropriate measures to avoid the freezing of drainage, moisture, etc., in low temperatures.

5. Mounting orientation

The Mounting orientation is free.

6. Initial lubrication of main valve

The initial lubricant has already been applied to the main valve.

7. For the pilot EXH port (breathing hole)

If the valve pilot EXH port (breathing hole) is restricted extremely or blocked, abnormal operation of the valve may occur.

Mounting

⚠ Warning

1. Operation manual

Install the products and operate them only after reading the operation manual carefully and understanding its contents. Also, keep the manual where it can be referred to as necessary.

2. Ensure sufficient space for maintenance activities.

When installing the products, allow access for maintenance and inspection.

3. Tighten threads with the proper tightening torque.

When installing the products, follow the listed torque specifications.

4. If air leakage increases or equipment does not operate properly, stop operation.

Check mounting conditions when air and power supplies are connected. Initial function and leakage tests should be performed after installation.

5. Painting and coating

Warnings or specifications printed on or affixed to the product should not be erased, removed, or covered up.

Also, applying paint to resinous parts, as this may have an adverse effect due to the solvent in the paint.

Piping

⚠ Caution

1. Refer to the Fittings and Tubing Precautions for handling One-touch fittings.

2. Refer to F.R.L/Common Precautions for screwing in piping materials.

3. For handling of silencers, refer to AN Series/Product Specific Precautions.

4. For handling of spacer with bracket, refer to AC-D Series/Product Specific Precautions.

Wiring

⚠ Warning

1. The valve is an electrical product. For safety, install an appropriate fuse and circuit breaker before use.

⚠ Caution

1. Polarity

When connecting power to a solenoid valve with a light or surge voltage suppressor, check for polarity.

If the polarity connection is wrong, the valve will not operate.

2. Applied voltage

When electric power is connected to valve, be careful to apply the proper voltage. Improper voltage may cause malfunction or coil damage.

3. Check the connections.

Check if the connections are correct after completing all wiring.

4. External force applied to the lead wire

If an excessive force is applied to the lead wire, this may cause faulty wiring. Take appropriate measures so that a force of 30 N or more is not applied to the lead wire.

When instructions are given in the Specific Product Precautions, follow these specifications.

Lubrication

⚠ Warning

1. Lubrication

1) Have been lubricated for life by the manufacturer and therefore do not require lubrication while in service.

2) If a lubricant is used in the system, use class 1 (no additives) and class 2 (with additives) ISO VG32 turbine oil.

For details about lubricant manufacturers' brands, refer to the SMC website.

Once lubricant is utilized within the system, since the original lubricant applied within the product during manufacturing will be washed away, please continue to supply lubrication to the system. Without continued lubrication, malfunctions could occur.

If turbine oil is used, refer to the Safety Data Sheet (SDS) of the oil.

2. Lubrication amount

If the lubrication amount is excessive, the oil may accumulate inside the pilot valve, causing malfunction or response delay.

Air Supply

⚠ Warning

1. Type of fluids

Be sure to use compressed air for the fluid.

2. When there is a large amount of drainage

Compressed air containing a large amount of drainage can cause the malfunction of pneumatic equipment. An air dryer or water separator should be installed upstream from filters.

3. Drain flushing

If condensation in the drain bowl is not emptied on a regular basis, the bowl will overflow. This may cause the malfunction of pneumatic equipment.

If the drain bowl is difficult to check and remove, the installation of a drain bowl with an auto drain option is recommended.

For compressed air quality, refer to the SMC Best Pneumatics catalog.



3/4/5-Port Solenoid Valves Precautions 3

Be sure to read this before handling products.

Air Supply

⚠ Warning

4. Use clean air.

Do not use compressed air that contains chemicals, synthetic oils that include organic solvents, salt, corrosive gases, etc., as it can cause damage or malfunction.

⚠ Caution

- 1. When low dew point air is used as the fluid, degradation of the lubrication properties inside the equipment may occur, resulting in reduced reliability (or reduced service life) of the equipment. Consider using products compatible with low dew points such as those from the 25A- series.**
- 2. Install an air filter.**
Install an air filter upstream near the valve. Select an air filter with a filtration size of 5 µm or smaller.
- 3. Take measures to ensure air quality, such as by installing an aftercooler, air dryer, or water separator.**
Compressed air that contains a large amount of drainage can cause the malfunction of pneumatic equipment, such as valves. Therefore, take appropriate measures to ensure air quality, such as by providing an aftercooler, air dryer, or water separator.
- 4. If an excessive amount of carbon powder is present, install a mist separator on the upstream side of the valve.**
If excessive carbon dust is generated by the compressor, it may adhere to the inside of a valve and cause it to malfunction.
For compressed air quality, refer to the SMC Best Pneumatics catalog.

Operating Environment

⚠ Warning

- 1. Do not use in an atmosphere containing corrosive gases, chemicals, sea water, water, water steam, or where there is direct contact with any of these.**
- 2. Products with IP65 enclosures (based on IEC60529) are protected against dust and water.**
However, these products cannot be used in water.
- 3. Products compliant with IP65 satisfy the product specifications when mounted properly.**
Be sure to read the precautions for each product.
- 4. Do not use in an environment where flammable gas or explosive gas exists. Usage may cause a fire or explosion. The products do not have an explosion proof construction.**
- 5. Do not use in a place subject to heavy vibration and/or shock.**
- 6. The valve should not be exposed to prolonged sunlight.**
Use a protective cover.
- 7. Remove any sources of excessive heat.**
- 8. If it is used in an environment where there is possible contact with oil, weld spatter, etc., exercise preventive measures.**
- 9. When the valve is mounted in a control panel, make sure the ambient temperature is within the specifications of the valve.**

⚠ Caution

1. Temperature of ambient environment

Use the valve within the range of the ambient temperature specification of each valve. In addition, pay attention when using the valve in environments where the temperature changes drastically.

2. Humidity of ambient environment

- When using the valve in environments with low humidity, take measures to prevent static.
- If the humidity rises, take measures to prevent the adhesion of water droplets on the valve.

Maintenance

⚠ Warning

- 1. Perform maintenance and inspection according to the procedures indicated in the operation manual.**
If handled improperly, human injury and/or malfunction or damage of machinery and equipment may occur.
- 2. Removal of equipment, and supply/exhaust of compressed air**
Before components are removed, first confirm that measures are in place to prevent workpieces from dropping, run-away equipment, etc. Then, cut off the supply air and electric power, and exhaust all air pressure from the system using the residual pressure release function. When the equipment is operated after remounting or replacement, first confirm that measures are in place to prevent the lurching of actuators, etc. Then, confirm that the equipment is operating normally.
- 3. Low-frequency operation**
Valves should be operated at least once every 30 days to prevent malfunction. (Use caution regarding the air supply.)
- 4. Manual override**
When a manual override is operated, connected equipment will be actuated.
Operate only after safety is confirmed.
- 5. If the volume of air leakage increases or the valve does not operate normally, do not use the valve.**
Perform periodic maintenance on the valve to confirm the operating condition and check for any air leakage.

⚠ Caution

1. Drain flushing

Remove drainage from the air filters regularly.

2. Lubrication

In the case of rubber seals, once lubrication has been started, it must be continued.

Use class 1 (no additives) and class 2 (with additives) ISO VG32 turbine oil. For details about lubricant manufacturers' brands, refer to the SMC website. If other lubricant oil is used, it may cause a malfunction.

VP300, 500, 700, 900 Series / 3-Port Solenoid Valve Modular Type/
Residual Pressure Relief Valve



Specific Product Precautions 1

Be sure to read this before handling

Manual Override

⚠ Warning

Without an electric signal for the solenoid valve the manual override is used for switching the main valve. Connected actuator is started by manual operation. Use the manual override after confirming that there is no danger.

■ Non-locking push type

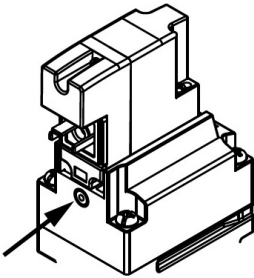

Press the manual override button with a small screwdriver until it stops. Release the screwdriver and the manual override will return.

■ Non-locking push type (Manual) (VP546E and VP746E only)

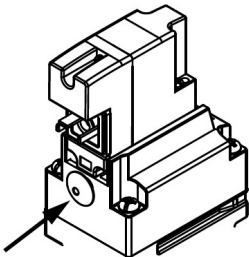

Press the manual override button with your finger until it stops. Release your finger and the manual override will return.

■ Push-turn locking type (Manual)

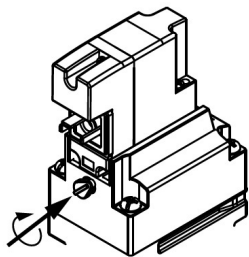

After pushing down, turn in the direction of the arrow. If it is not turned, it can be operated the same way as the non-locking type.

⚠ Caution

When locking the manual override with the push-turn locking type, be sure to push it down before turning. Turning without first pushing it down can cause damage to the manual override and other trouble such as air leakage, etc. Do not apply excessive torque when turning the locking type manual override. (0.1 N·m)

How to Use DIN Terminal Connector

⚠ Caution

● Connection

1. Loosen the holding screw and pull the connector out of the solenoid valve terminal block.
2. After removing the holding screw, insert a flat blade screwdriver, etc., into the notch on the bottom of the terminal block and pry it open, separating the terminal block and the housing.
3. Loosen the terminal screws (slotted screws) in the terminal block. Insert the lead core wires into the terminals according to the connection method, and secure the wires by re-tightening the terminal screws.
4. Secure the cord by fastening the gland nut.

- When making connections, please note that using a heavy-duty cord of a size outside of the range of supported sizes ($\varnothing 3.5$ to $\varnothing 7$) will not satisfy IP65 (enclosure) standards. Also, be sure to tighten the gland nut and holding screw within their specified torque ranges.
- After separating the terminal block and housing, the cord entry direction can be changed by rotating the housing in the desired direction (4 directions at 90° intervals).
* When equipped with a light, be careful not to damage the light with the cord's lead wires.
- Plug in and pull out the connector vertically without tilting it to one side.

● Compatible cable

Cord O.D.: $\varnothing 3.5$ to $\varnothing 7$
(Reference) 0.5 mm², 2-core or 3-core, equivalent to JIS C 3306

● Applicable crimped terminal

Ferrule: Weidmueller H0.5/6 (0.3 to 0.5 mm²), or equivalent.

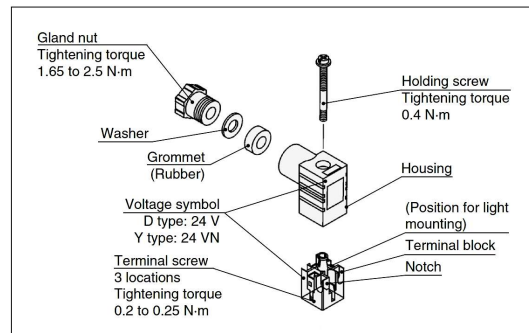

● “Y” type

- The Y type DIN connector is in compliance with the DIN standard of a 8 mm pitch between terminals.
- It is not interchangeable with the D type DIN connector with a 9.4 mm pitch between terminals.
 - To distinguish it from the D type DIN connector, “N” is listed at the end of voltage symbol.
 - The dimensions are the same as those of the D type DIN connector.



VP300, 500, 700, 900 Series / 3-Port Solenoid Valve Modular Type/ Residual Pressure Relief Valve

Specific Product Precautions 2

Be sure to read this before handling

Light/Surge Voltage Suppressor

DIN Terminal

With light/surge voltage suppressor (DZ,YZ)

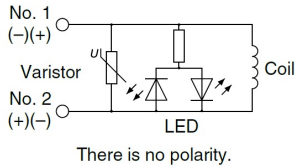

For M12 connector

With light / surge voltage suppressor (KOZ)

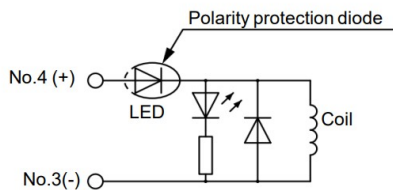

Pilot valve pin arrangement diagram for M12 connector

A coded , Plug

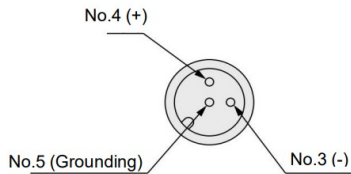

* The varistor surge voltage suppressor has residual voltage corresponding to the protective element and rated voltage; therefore, protect the controller side from the surge voltage.

Valve EXH.[3(R)] port

Caution

Do not plug the 3(R) port of this valve as it is a residual pressure relief valve.

Size	Silencer	
VP346E	AC20	AN20-02, AN202-02
VP546E	AC30	AN30-03, AN302-03
VP746E	AC40	AN40-04, AN402-04
VP946E	AC50 AC60	AN600-10, ANA1-10

Built-in check valve

Warning

A check valve is built into the pilot flow path to suppress the pilot pressure drop due to pressure fluctuation in the inlet side. There is a residual pressure between the check valve and the pilot valve, please be careful when replacing the pilot valve.

Soft start-up function

When the soft start-up function is selected, the initial pressure of the pneumatic system can be increased gradually.

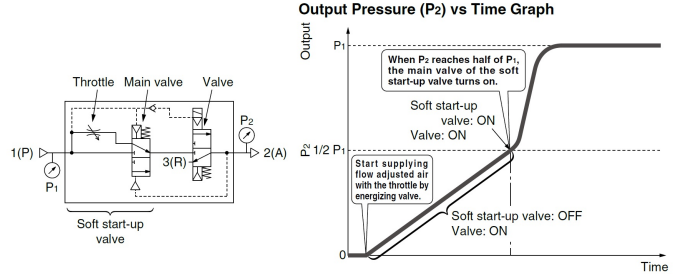

Adjustment method

Turn the needle of the throttle valve to the left from fully closed (as shipped) to adjust the initial speed of the drive equipment on the outlet side.

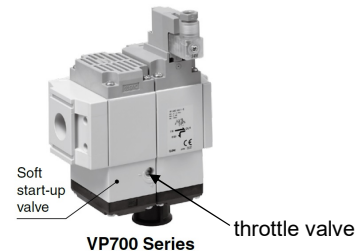

UL Approved Product

Caution

When conformity to UL is required, the product should be used with a UL1310 Class 2 power supply.

The product is a UL approved product only if it has a  mark on the body.



VP300, 500, 700, 900 Series / 3-Port Solenoid Valve Modular Type/ Residual Pressure Relief Valve

Specific Product Precautions 3

Be sure to read this before handling

Piping

Connection threads are not available for the residual pressure relief 3-port solenoid valve.

Piping adapter and spacer with bracket must be ordered separately.

Please refer to the AC-D series/product-specific precautions for handling.

●Piping Adapter

E **300** - **03** - D
 ① ② ③

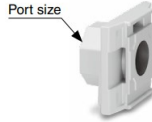

	Symbol	Description	① Body size [Applicable AC size]			
			200 [AC20]	300 [AC30]	400 [AC40]	600 [AC50, AC60]
② Pipe thread type	Nil	Rc	●	●	●	●
	N	NPT	●	●	●	●
	F	G	●	●	●	●
+						
③ Port size	01	1/8	●	—	—	—
	02	1/4	●	●	—	—
	03	3/8	●	●	●	—
	04	1/2	—	●	●	—
	06	3/4	—	—	●	●
	10	1	—	—	—	●
	12	1 1/4	—	—	—	●
14	1 1/2	—	—	—	●	

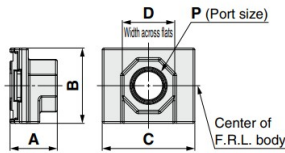

Model	P	A	B	C	D	Applicable AC size
E200-D	1/8, 1/4, 3/8	24	35	42	24	AC20-D
E300-D	1/4, 3/8, 1/2	27	43	53	30	AC30-D
E400-D	1/4, 3/8, 1/2, 3/4	30	51	71	36	AC40-D
E600-D	3/4, 1	39	64	90	46	AC50-D
	1 1/4, 1 1/2	42	64	90	63	AC60-D

●Spacer with Bracket

Y **300** T - D
 ① ②



	Symbol	Description	① Body size [Applicable AC size]			
			200 [AC20]	300 [AC30]	400 [AC40]	600 [AC50/AC60]
② Bracket	T	Spacer with bracket	●	●	●	●

Spacer with bracket

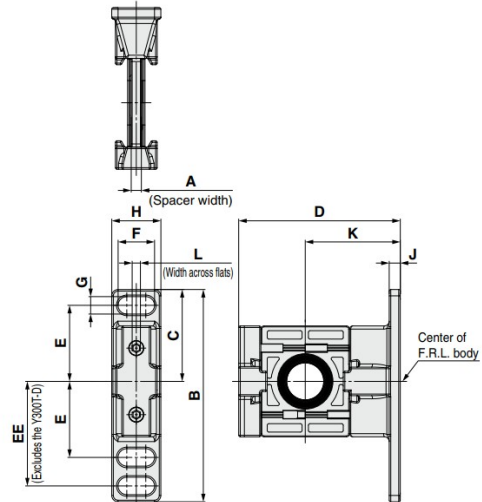

Model	A	B	C	D	E	EE	F	G	H	J	K	L	Applicable size
Y200T-D	3.2	67	29	51	24	33	11.5	5.5	15.5	3.5	30	2	AC20-D
Y300T-D	4.2	85	42.5	67.5	35	—	14	7	20	6	41	3	AC30-D
Y400T-D	5.2	115	50	85.5	40	55	18	9	26	7	50	3	AC40-D
Y600T-D	6.2	140	60	115	50	70	20	11	31.2	8	70	4	AC50-D
													AC60-D

Trouble shooting

Problem	When the valve is failing, use this flow chart to clarify the cause of the failure and take countermeasures appropriate for the cause.	Possible cause	Countermeasures
Operation failure Air is not switched.	<p>The valve operate when the manual override button is pushed?</p> <p>YES</p>	1) Operation failure or sticking of the main valve. <ul style="list-style-type: none"> ● Foreign matter from the piping and air source got caught in the main valve of the valve, causing a malfunction. ● Malfunction occurred due to sticking such as swelling of the rubber part of the main valve. 	<ul style="list-style-type: none"> - Replace the valve. - Clean the air supply. - If incorrect oil has been used for lubrication, remove the oil by air blow. - If there is a large amount of condensate, install an auto drain or a dryer.
	<p>Energized? Is valve switched?</p> <p>YES</p>	2) Reduced pressure Air source pressure is reduced and minimum operating pressure of the valve was not reached, causing an operation failure.	<ul style="list-style-type: none"> - Adjust the pressure within the specification range for the valve.
	<p>1) Leakage current</p> <p>Operation failure of the valve occurred due to residual voltage. (Valve is not turned OFF)</p>	3) Excessive oil supply Due to excessive lubrication, oil accumulated inside the valve, causing malfunction.	<ul style="list-style-type: none"> - Reduce the amount of lubrication to the amount at which the oil does not splash from the exhaust port [3(R), vent port].
	<p>2) Non-conformance of the installed pilot valve</p> <p>Foreign matter is caught in the moving part of the valve (or pilot valve). Swelling of rubber parts inside the valve (or pilot valve)</p>	1) Non-conforming of electric system <ul style="list-style-type: none"> - Incorrect wiring - Fuse blown out, lead wire broken - Incorrect contact at the contact and connection - Sequencer non-conforming - Supply voltage insufficient 	<ul style="list-style-type: none"> - Check all parts and replace the part, if necessary. - Check the supply voltage.
		2) Drop of supply voltage Operation failure of the valve due to voltage drop.	<ul style="list-style-type: none"> - Check the supply voltage. Take corrective action if voltage drop is confirmed.
		3) Non-conforming of the installed pilot valve <ul style="list-style-type: none"> - Broken wire in the coil or burnout (High supply voltage, incorrect coil specification, entry of water) 	<ul style="list-style-type: none"> - Replace the valve.
		2) Non-conformance of the installed pilot valve <ul style="list-style-type: none"> - Foreign matter is caught in the moving part of the valve (or pilot valve). - Swelling of rubber parts inside the valve (or pilot valve) 	<ul style="list-style-type: none"> - Check the residual voltage. - Keep the residual voltage at 3% or less of the rated voltage (DC coil).
		2) Non-conformance of the installed pilot valve <ul style="list-style-type: none"> - Foreign matter is caught in the moving part of the valve (or pilot valve). - Swelling of rubber parts inside the valve (or pilot valve) 	<ul style="list-style-type: none"> - Clean the air supply. - Eliminate foreign matter with air blow. - Replace the valve when actions above do not improve the condition.

Problem	When the valve is failing, use this flow chart to clarify the cause of the failure and take countermeasures appropriate for the cause.	Possible cause	Countermeasures
Response failure Valve and actuator become slow.	<div style="border: 1px solid black; border-radius: 10px; padding: 5px; width: fit-content; margin: 10px auto;"> The valve is slow. Actuators including cylinder become slow. </div>	<p>1) Leakage current When the valve is turned off, it became slow due to the residual voltage.</p> <p>2) Clogging of the filter and silencer Filter or silencer is clogged, or vent port is blocked.</p> <p>3) Operation failure or sticking of the main valve. Foreign matter from the piping and air source got caught in the main valve of the valve, causing a delay. Malfunction occurred due to sticking such as swelling of the rubber part of the main valve.</p>	<p>Check the residual voltage. Keep the residual voltage at 3% of the rated voltage (DC coil) or less.</p> <p>- Replace the filter. - Replace the silencer. - Do not block the valve vent port.</p> <p>- Replace the valve. - Check for abnormalities in devices other than valves. - Clean the air supply. - If incorrect oil has been used for lubrication, remove the oil by air blow. - If there is a large amount of condensate, install an auto drain or a dryer.</p>
Air leakage	<div style="border: 1px solid black; border-radius: 10px; padding: 5px; width: fit-content; margin: 10px auto;"> Find and check the air leakage point. </div> <div style="display: flex; justify-content: space-around; margin-top: 10px;"> <div style="border: 1px solid black; border-radius: 10px; padding: 5px; width: 30%;"> 1. Air leakage from OUT. [2(A)] port or EXH. [3(R)] port. </div> <div style="font-size: 2em;">➔</div> </div> <div style="display: flex; justify-content: space-around; margin-top: 10px;"> <div style="border: 1px solid black; border-radius: 10px; padding: 5px; width: 30%;"> 2. Air leakage from the vent port. </div> <div style="font-size: 2em;">➔</div> </div>	<p>1) Internal air leakage increased because foreign matter get caught in the main valve.</p> <p>2) Sealing failure of the actuator (cylinder)</p> <p>1) Foreign matter is caught in the pilot valve armature.</p> <p>2) Foreign matter caught in the valve seat</p>	<p>- Replace the valve. - Clean the air supply.</p> <p>- Refer to the operation manual of the actuator for details.</p> <p>- Replace the valve. - Clean the air supply.</p> <p>- Replace the valve. - Clean the air supply.</p>

If the countermeasures above are not effective, there may be a problem with the valve.
 Stop using the valve immediately.

If any of the examples below are applicable, there may be an internal problem with the valve. Stop using the valve immediately.

1. The voltage used was not the rated voltage.
2. The oil supplied was not the specified type.
3. Lubrication was stopped during operation. Or, lubrication was interrupted temporarily.
4. The product was directly exposed to water with the valve cover, connector block or SI unit removed.
5. Severe impact was applied.
6. Foreign matter such as condensate or dust has entered the product
7. Other than those specified, if precautions on the operation manual apply.

* In addition, if you request us to investigate, please send the valve back to us in its original condition with out disassembling it.

Revision history

B	VP300 and VP900 added	
	Some corrections	2024.7
C	Precautions for Solenoid Valve	2024.11
D	Applicable crimped terminal	2026.4

SMC Corporation

Tel: + 81 3 5207 8249 Fax: +81 3 5298 5362

URL <https://www.smcworld.com>

Note: Specifications are subject to change without prior notice and any obligation on the part of the manufacturer.
© SMC Corporation All Rights Reserved
ration All Rights Reserved

No.VP500-OMZ0005-D