



Operation Manual

PRODUCT NAME

BLOW GUN

MODEL/ Series/ Product Number

VMG

SMC Corporation

Contents

	Page
1. Safety Instructions	2-7
2. Features	8
3. Specifications	8
4. Construction	9
5. Optional parts	10-11
6. Applicable S coupler (socket)	11
7. How to mount an extension nozzle to the blow gun (VMG series)	12



Safety Instructions

These safety instructions are intended to prevent hazardous situations and/or equipment damage. These instructions indicate the level of potential hazard with the labels of “**Caution**,” “**Warning**” or “**Danger**.” They are all important notes for safety and must be followed in addition to International Standards (ISO/IEC)^{*1)}, and other safety regulations.

*1) ISO 4414: Pneumatic fluid power - General rules and safety requirements for systems and their components
ISO 4413: Hydraulic fluid power - General rules and safety requirements for systems and their components
IEC 60204-1: Safety of machinery - Electrical equipment of machines - Part 1: General requirements
ISO 10218-1: Robots and robotic devices - Safety requirements for industrial robots - Part 1: Robots
etc.

	Danger	Danger indicates a hazard with a high level of risk which, if not avoided, will result in death or serious injury.
	Warning	Warning indicates a hazard with a medium level of risk which, if not avoided, could result in death or serious injury.
	Caution	Caution indicates a hazard with a low level of risk which, if not avoided, could result in minor or moderate injury.

Warning

1. The compatibility of the product is the responsibility of the person who designs the equipment or decides its specifications.

Since the product specified here is used under various operating conditions, its compatibility with specific equipment must be decided by the person who designs the equipment or decides its specifications based on necessary analysis and test results. The expected performance and safety assurance of the equipment will be the responsibility of the person who has determined its compatibility with the product. This person should also continuously review all specifications of the product referring to its latest catalog information, with a view to giving due consideration to any possibility of equipment failure when configuring the equipment.

2. Only personnel with appropriate training should operate machinery and equipment.

The product specified here may become unsafe if handled incorrectly. The assembly, operation and maintenance of machines or equipment including our products must be performed by an operator who is appropriately trained and experienced.

3. Do not service or attempt to remove product and machinery/equipment until safety is confirmed.

1. The inspection and maintenance of machinery/equipment should only be performed after measures to prevent falling or runaway of the driven objects have been confirmed.
2. When the product is to be removed, confirm that the safety measures as mentioned above are implemented and the power from any appropriate source is cut, and read and understand the specific product precautions of all relevant products carefully.
3. Before machinery/equipment is restarted, take measures to prevent unexpected operation and malfunction.

4. Our products cannot be used beyond their specifications. Our products are not developed, designed, and manufactured to be used under the following conditions or environments. Use under such conditions or environments is not covered.

1. Conditions and environments outside of the given specifications, or use outdoors or in a place exposed to direct sunlight.
2. Use for nuclear power, railways, aviation, space equipment, ships, vehicles, military application, equipment affecting human life, body, and property, fuel equipment, entertainment equipment, emergency shut-off circuits, press clutches, brake circuits, safety equipment, etc., and use for applications that do not conform to standard specifications such as catalogs and operation manuals.
3. Use for interlock circuits, except for use with double interlock such as installing a mechanical protection function in case of failure. Please periodically inspect the product to confirm that the product is operating properly.



Safety Instructions

Caution

We develop, design, and manufacture our products to be used for automatic control equipment, and provide them for peaceful use in manufacturing industries.

Use in non-manufacturing industries is not covered.

Products we manufacture and sell cannot be used for the purpose of transactions or certification specified in the Measurement Act.

The new Measurement Act prohibits use of any unit other than SI units in Japan.

Limited warranty and Disclaimer/Compliance Requirements

The product used is subject to the following “Limited warranty and Disclaimer” and “Compliance Requirements”. Read and accept them before using the product.

Limited warranty and Disclaimer

1. The warranty period of the product is 1 year in service or 1.5 years after the product is delivered, whichever is first.* 2)
Also, the product may have specified durability, running distance or replacement parts. Please consult your nearest sales branch.
2. For any failure or damage reported within the warranty period which is clearly our responsibility, a replacement product or necessary parts will be provided.
This limited warranty applies only to our product independently, and not to any other damage incurred due to the failure of the product.
3. Prior to using SMC products, please read and understand the warranty terms and disclaimers noted in the specified catalog for the particular products.

***2) Vacuum pads are excluded from this 1 year warranty.**

A vacuum pad is a consumable part, so it is warranted for a year after it is delivered.

Also, even within the warranty period, the wear of a product due to the use of the vacuum pad or failure due to the deterioration of rubber material are not covered by the limited warranty

Compliance Requirements

1. The use of SMC products with production equipment for the manufacture of weapons of mass destruction (WMD) or any other weapon is strictly prohibited.
2. The exports of SMC products or technology from one country to another are governed by the relevant security laws and regulations of the countries involved in the transaction. Prior to the shipment of a SMC product to another country, assure that all local rules governing that export are known and followed.

Selection



Warning

1. Check the specifications.

The product is designed for use only in compressed air systems. Do not operate at pressures or temperatures, etc., beyond the range of specifications, as this can cause damage or malfunction.



Caution

1. Do not use the product with flammable, explosive, or toxic substances such as gas, gas fuel, and refrigerants. Such substances may permeate from inside the blow gun.

Mounting



Warning

1. Install a stop valve on the supply pressure side of the blow gun.

It will be emergency shut off in case of unexpected leakage or damage.

2. When installing a nozzle in the blow gun, wrap a sealant tape around the threads of the nozzle.
3. When installing the nozzle, first, tighten the threaded portion by hand, then use a wrench, secure the nozzle holder of the blow gun with a 22mm spanner without applying force to the body, and tighten the nozzle further two or three turns. As a reference value for the tightening torque, refer to the table below.

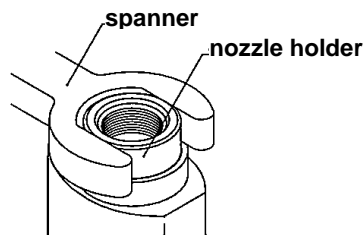

Nozzle tightening torque range	8 to 12 N · m
--------------------------------	---------------

Insufficient tightening may cause nozzle loosening.

4. When mounting the copper extension nozzle, follow the instructions "How to mount an extension nozzle to the blow gun (VMG series)" on page 12.

Piping



Caution

1. Before mounting, check the model, size, etc.

Also, check that there are no scratches, dents or cracks in the product.

2. Preparation before piping.

Before piping is connected, flush thoroughly with air or wash to remove chips, cutting oil and other debris from inside the pipe.

3. Sealant tape

When screwing piping or fittings into ports, ensure that chips from the pipe threads or sealing material do not enter the blow gun. If sealant tape is used, leave 1.5 to 2 thread ridges exposed at the end of the threads.

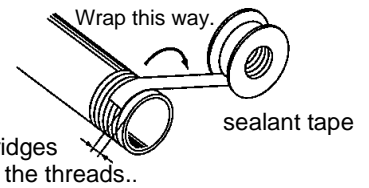

4. When tightening a fitting or coupler into the port, first, tighten the threaded portion by hand, then apply spanner of the width across flats of 22 to the width across flats of the port of the blow gun to avoid force being applied to the product body, tighten it a further two or three turns. Use the tightening torque specified in the table below.

Using an excessive tightening torque that is larger than the specified in the table below may damage the unit.

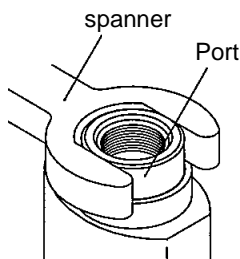

Male thread	torque
R1/4	8 to 12
R3/8	15 to 20

5. When connecting a tube, consider factors such as changes in the tubing length due to pressure, and allow sufficient leeway.
6. Make sure that no twist, turn, tensile force or moment load is applied on the port or tube. It may cause the fitting to fracture or the tube to crush, burst or come off.
7. Mount so that tubing is not damaged by becoming entangled or abrasion. This can cause crushing, bursting or disconnection of tubing, etc.

Lubrication



Warning

1. Do not introduce oil into the air supply.

This can damage or contaminate the object to be blown.

Air Supply



Warning

1. Use clean air.

Do not use compressed air that contains chemicals, synthetic oils including organic solvents, salt or corrosive gases, etc., as it can cause damage or malfunction.



Caution

1. Install air filters.

Install air filters close to the blow gun on the upstream side. A filtration degree of 5 micron millimeter or less should be selected.

2. Take appropriate measures to ensure air quality, such as by providing an aftercooler, air dryer, or water separator.

Compressed air containing a lot of contaminants may cause operation failure of the blow gun or contamination/damage of the object to be blown. Therefore, take appropriate measures to ensure air quality, such as by providing an after cooler, water separator.

Operating environment



Warning

- 1. Do not use in an environment where corrosive gases, chemicals, sea water, water or steam are present.**
- 2. If using in a location directly exposed to sunlight, shade the product from the sunlight.**
- 3. Do not mount the product in locations where it is exposed to radiant heat.**
- 4. Do not use the product in a place where static electricity is a problem. It may result in system failure or malfunction.**
- 5. Do not use the product in a place where welding spatter can splash or get inside the product, as it may cause the product to catch fire.**
- 6. Do not use in an environment where the product is directly exposed to cutting oil, lubricant oil or coolant liquid, etc. Consult with SMC if using in such an environment.**

Maintenance



Caution

- 1. Please check the following points in the regular maintenance, and replace the parts as necessary.**
 - a) Scratches, dent, frictional wear, corrosion
 - b) Air leakage
 - c) Squeezing or twisting of the tubing that is connected
 - d) Hardening, deterioration or softening of the tubing that is connected
 - e) Loosening of the nozzle
- 2. Before removing the product, stop the supply pressure and exhaust compressed air in the piping.**
- 3. Do not modify or reconstruct the product.**

Handling



Warning

- 1. To prevent lurching of the nozzle due to air pressure, confirm that the nozzle is not loosened or rattling by pulling it by hand before operation.**
- 2. Be sure to wear safety goggles to protect the eyes from splashed substances.**
- 3. Do not direct the tip of the nozzle at the face or any other parts of the human body. It may cause injury to personnel.**
- 4. Do not use the product to clean or remove toxic substances or chemicals.**
- 5. Do not drop, step on or hit the product. This may cause damage.**

6. If product is to be used in a public place, ensure product is not directed at people or used in a manner that could adversely affect the environment.

7. This product is not a toy.

8. After blowing, be sure to hang the product on a hook, etc.

If leaving the product in a dusty place, particles will enter the product and may result in malfunction.

9. Make sure that no twist, turn, tensile force or moment load is applied on the port or tube when using or storing the blow gun.

It may cause the fitting to fracture or the tube to crush, burst or come off.

10. When mounting a nozzle cover, align the hexagon part of the nozzle cover with the hexagon part of the nozzle.

When mounting the extended nozzle cover, ensure that the tip of the nozzle is inserted to the back of the extended nozzle cover.

11. When there are cracks or play with the nozzle cover or the extended nozzle cover, replace with a new one.

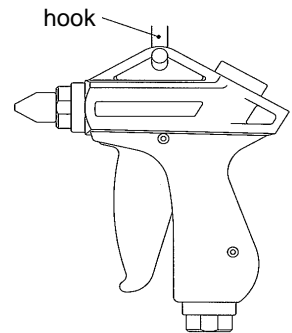

2. Features

1. Constant operational force irrespective of supply pressure

Due to the balanced design of the product, the operating force will not be affected by changes in the supply pressure.

For example, when it is used in the production and work lines using different pressure from each other in a factory, it can provide the same operational force.

2. Top or bottom piping and nozzles are selectable.

The top or bottom piping can be selected for each application and piping position. Also, the nozzle mounted to the end of the product can be chosen.

3. Energy saving valve design

The orifice shape of the main valve is improved to give a large effective area and reduce pressure loss.

4. Hand fitting design

The product is designed to fit the hand comfortably when gripped.

3. Specifications

Fluid	Air
Operating pressure range	0 to 1.0 MPa
Proof pressure	1.5 MPa
Ambient and fluid temperature range	-5 to 60 °C (No freezing)
Effective area (Without nozzle)	C (dm ³ /s-bar): 6.0, b: 0.25 (Effective area: 30 mm ²)
Port size	Rc, NPT, G 1/4 , 3/8
Piping direction	Bottom or Top
Nozzle port size	Rc1/4
Weight	165g
Operation force (When fully open)	7N

4. Construction

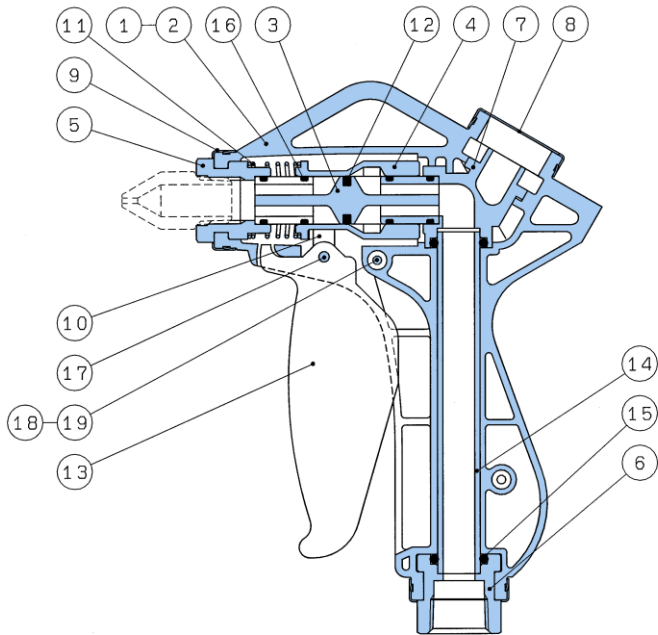

Components

No.	Description	Material	Remarks
1	Body L	PBT	
2	Body R	PBT	
3	Main valve	PBT	
4	Valve guide	POM	
5	Nozzle holder	Aluminum alloy	Anodized
6	Port	Aluminum alloy	Anodized
7	Elbow	PBT	Used only for VMG12*
8	Cover	Stainless steel	
9	Ring	Stainless steel	
10	Arm	PBT	
11	Spring	Stainless steel	
12	Main valve seal	HNBR	
13	Lever	PBT	
14	Piping (bottom)	POM	Used only for VMG11*
15	O-ring	NBR	
16	O-ring	NBR	
17	Parallel pin	Stainless steel	
18	Cross recessed round head screw	Stainless steel	
19	Hexagon nut	Stainless steel	

* Grease is applied to the rubber parts and the sliding parts.

5. Optional parts

Nozzle with male thread/ KN



Model	Nozzle size
KN-R02-100	ø1
KN-R02-150	ø1.5
KN-R02-200	ø2
KN-R02-250	ø2.5
VMG1-R02-300	ø3
VMG1-R02-350	ø3.5
VMG1-R02-400	ø4

High efficiency type nozzle/ KNH



Model	Nozzle size
KNH-R02-100	ø1
KNH-R02-150	ø1.5
KNH-R02-200	ø2

Low noise type nozzle with male thread/ KNS



Model	Nozzle size
KNS-R02-075-4	ø0.75x4
KNS-R02-090-8	ø0.9x8
KNS-R02-100-4	ø1x4
KNS-R02-110-8	ø1.1x8

Extended copper nozzle set



Model	Nozzle size	O.D.	Extended nozzle length
VMG1-06-150-100	ø1.5	ø6	100
VMG1-06-200-100	ø2		
VMG1-06-150-150	ø1.5		150
VMG1-06-200-150	ø2		
VMG1-06-150-300	ø1.5		300
VMG1-06-200-300	ø2		
VMG1-06-150-600	ø1.5		600
VMG1-06-200-600	ø2		
VMG1-08-250-100	ø2.5	ø8	100
VMG1-08-300-100	ø3		
VMG1-08-350-100	ø3.5		
VMG1-08-250-150	ø2.5		150
VMG1-08-300-150	ø3		
VMG1-08-350-150	ø3.5		
VMG1-08-250-300	ø2.5		300
VMG1-08-300-300	ø3		
VMG1-08-350-300	ø3.5		
VMG1-08-250-600	ø2.5		600
VMG1-08-300-600	ø3		
VMG1-08-350-600	ø3.5		

Note) The extended copper nozzle and the self-align fitting are shipped together without being assembled. Refer to "How to mount an extension nozzle to the blow gun (VMG series)" on page 12 for the assembly instructions.

Nozzle cover with male thread



Model	Material	Applicable VMG model	Nozzle type
P5670129-01	HNBR	VMG1**-*-01 to 04	Nozzle with male thread ø1 to ø2.5
P5670129-01F	Fluororubber		
P5670129-02	HNBR	VMG1**-*-05 to 07	Nozzle with male thread ø3 to ø4
P5670129-02F	Fluororubber		

Extended copper nozzle cover



Model	Material	Applicable VMG model	Nozzle type
P5670129-11	HNBR	VMG1**-*-31 to 38	ø6 copper tube Extended nozzle
P5670129-11F	Fluororubber		

6. Applicable S coupler (socket)

VMG model	Socket type	Model
VMG1**-11-* (With KK4P-02MS)	Male thread type	KK4S-02 to 04MS
	Female thread type	KK4S-02 to 03F
	Nut fitting type (For fiber reinforced urethane hose)	KK4S-50 to 85N
	With One-touch fitting Straight	KK4S-06 to 12H
	With One-touch fitting Elbow	KK4S-06 to 12L
VMG1**-12-* (With KK130P-02MS)	Male thread	KK130*-02 to 04MS
	Female thread	KK130*-02 to 04F
	With barb fitting (For rubber hose)	KK130*-07 to 13B
	Nut fitting (For fiber reinforced urethane hose)	KK130*-50 to 110N
	With One-touch fitting Straight	KK130*-06 to 12H

Refer to pages for tube fittings & tubings shown in the SMC's website
(URL <https://www.smcworld.com>) for details.

7. How to mount an extended nozzle to the blow gun (VMG Series)

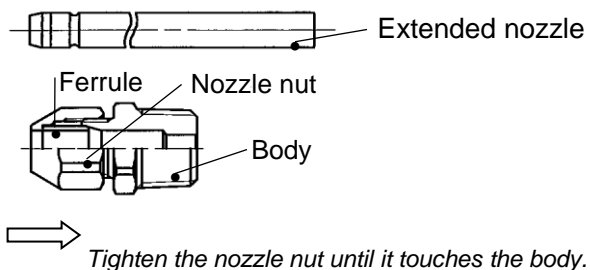
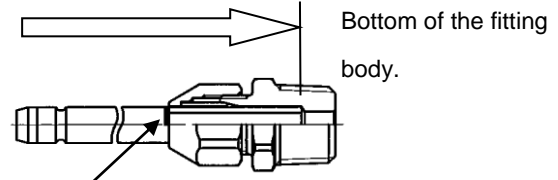
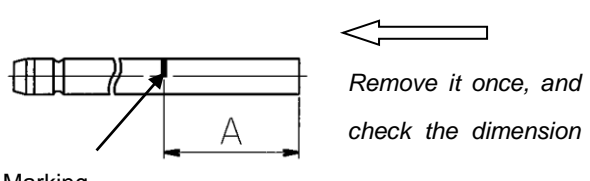
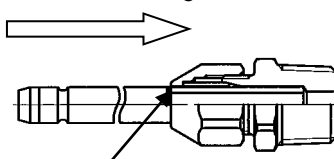
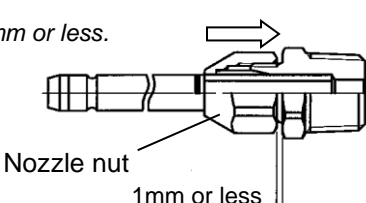
Preparation	<p>1. Check that the ferrule is mounted inside the fitting as shown in figure on the right. Hand-tighten the nozzle nut. Ensure ferrule is aligned properly.</p>	 <p style="text-align: center;"><i>Tighten the nozzle nut until it touches the body.</i></p>			
	<p>2. Insert the extended nozzle until it touches the fitting body. Then, mark a line on the extended nozzle at the edge of the nozzle nut.</p>	<p style="text-align: center;"><i>Insert the extended nozzle until it touches the bottom of the fitting body.</i></p>  <p style="text-align: center;">Put a mark.</p>			
	<p>3. Remove the extended nozzle once, and check the dimension A from the end of the extended nozzle to the marking.</p> <p>If the dimension A is different from the chart on the right, verify the alignment of the extended nozzle and adjust.</p>	<table border="1" style="width: 100%; border-collapse: collapse;"> <tr> <td style="padding: 5px;">Extended nozzle O.D. 6</td> <td style="padding: 5px;">A = Approx. 23 mm</td> </tr> <tr> <td style="padding: 5px;">Extended nozzle O.D. 8</td> <td style="padding: 5px;">A = Approx. 24 mm</td> </tr> </table>  <p style="text-align: center;"><i>Remove it once, and check the dimension</i></p>	Extended nozzle O.D. 6	A = Approx. 23 mm	Extended nozzle O.D. 8
Extended nozzle O.D. 6	A = Approx. 23 mm				
Extended nozzle O.D. 8	A = Approx. 24 mm				
Tightening	<p>4. After verifying the dimension A, insert the extended nozzle into the fitting body again.</p> <p>Confirm that the extended nozzle is inserted down to the marking.</p>	<p style="text-align: center;"><i>Insert to the marking.</i></p>  <p style="text-align: center;">Marking</p>			
	<p>5. Tighten the nozzle nut until the clearance between the fitting body and the nozzle nut is 1 mm or less.</p> <p>6. Pull the extended nozzle by hand to ensure that the extended nozzle is secure.</p>	<p style="text-align: center;"><i>Tighten the nozzle nut until the clearance becomes 1 mm or less.</i></p>  <p style="text-align: center;">Nozzle nut 1mm or less</p>			

Revision history	
A: Models added, Changes in the descriptions shown in "How to mount an extended nozzle to the Blow-Gun (Series VMG)", changes the torque.	
B: Safety Instructions added.	
C: Safety Instructions changed. Extended copper nozzle set corrected on page 10.	2023.12
D: Updated formats.	Mar/26/2024

SMC Corporation

Tel: + 81 3 5207 8249 Fax: +81 3 5298 5362
 URL <https://www.smcworld.com>

Note: Specifications are subject to change without prior notice and any obligation on the part of the manufacturer.
 © SMC Corporation All Rights Reserved