



Operation Manual

Product name

Hand Valve

Model / Series / Product Number

VH Series

SMC Corporation

Contents

- 1. Safety Instructions ----- 1 to 7
- 2. Application ----- 8
- 3. Specification ----- 8
- 4. How to Order ----- 9
- 5. Construction / Parts list ----- 10



Safety Instructions

These safety instructions are intended to prevent hazardous situations and/or equipment damage. These instructions indicate the level of potential hazard with the labels of “**Caution**,” “**Warning**” or “**Danger**.” They are all important notes for safety and must be followed in addition to International Standards (ISO/IEC)^{*1)}, and other safety regulations.

*1) ISO 4414: Pneumatic fluid power - General rules and safety requirements for systems and their components
ISO 4413: Hydraulic fluid power - General rules and safety requirements for systems and their components
IEC 60204-1: Safety of machinery - Electrical equipment of machines - Part 1: General requirements
ISO 10218-1: Robots and robotic devices - Safety requirements for industrial robots - Part 1: Robots
etc.



Danger

Danger indicates a hazard with a high level of risk which, if not avoided, will result in death or serious injury.



Warning

Warning indicates a hazard with a medium level of risk which, if not avoided, could result in death or serious injury.



Caution

Caution indicates a hazard with a low level of risk which, if not avoided, could result in minor or moderate injury.

Warning

1. The compatibility of the product is the responsibility of the person who designs the equipment or decides its specifications.

Since the product specified here is used under various operating conditions, its compatibility with specific equipment must be decided by the person who designs the equipment or decides its specifications based on necessary analysis and test results. The expected performance and safety assurance of the equipment will be the responsibility of the person who has determined its compatibility with the product. This person should also continuously review all specifications of the product referring to its latest catalog information, with a view to giving due consideration to any possibility of equipment failure when configuring the equipment.

2. Only personnel with appropriate training should operate machinery and equipment.

The product specified here may become unsafe if handled incorrectly. The assembly, operation and maintenance of machines or equipment including our products must be performed by an operator who is appropriately trained and experienced.

3. Do not service or attempt to remove product and machinery/equipment until safety is confirmed.

1. The inspection and maintenance of machinery/equipment should only be performed after measures to prevent falling or runaway of the driven objects have been confirmed.
2. When the product is to be removed, confirm that the safety measures as mentioned above are implemented and the power from any appropriate source is cut, and read and understand the specific product precautions of all relevant products carefully.
3. Before machinery/equipment is restarted, take measures to prevent unexpected operation and malfunction.

4. Our products cannot be used beyond their specifications. Our products are not developed, designed, and manufactured to be used under the following conditions or environments. Use under such conditions or environments is not covered.

1. Conditions and environments outside of the given specifications, or use outdoors or in a place exposed to direct sunlight.
2. Use for nuclear power, railways, aviation, space equipment, ships, vehicles, military application, equipment affecting human life, body, and property, fuel equipment, entertainment equipment, emergency shut-off circuits, press clutches, brake circuits, safety equipment, etc., and use for applications that do not conform to standard specifications such as catalogs and operation manuals.
3. Use for interlock circuits, except for use with double interlock such as installing a mechanical protection function in case of failure. Please periodically inspect the product to confirm that the product is operating properly.



Safety Instructions

Caution

We develop, design, and manufacture our products to be used for automatic control equipment, and provide them for peaceful use in manufacturing industries.

Use in non-manufacturing industries is not covered.

Products we manufacture and sell cannot be used for the purpose of transactions or certification specified in the Measurement Act.

The new Measurement Act prohibits use of any unit other than SI units in Japan.

Limited warranty and Disclaimer/Compliance Requirements

The product used is subject to the following “Limited warranty and Disclaimer” and “Compliance Requirements”. Read and accept them before using the product.

Limited warranty and Disclaimer

1. The warranty period of the product is 1 year in service or 1.5 years after the product is delivered, whichever is first.*2)
Also, the product may have specified durability, running distance or replacement parts. Please consult your nearest sales branch.
2. For any failure or damage reported within the warranty period which is clearly our responsibility, a replacement product or necessary parts will be provided.
This limited warranty applies only to our product independently, and not to any other damage incurred due to the failure of the product.
3. Prior to using SMC products, please read and understand the warranty terms and disclaimers noted in the specified catalog for the particular products.

***2) Vacuum pads are excluded from this 1 year warranty.**

A vacuum pad is a consumable part, so it is warranted for a year after it is delivered.

Also, even within the warranty period, the wear of a product due to the use of the vacuum pad or failure due to the deterioration of rubber material are not covered by the limited warranty

Compliance Requirements

1. The use of SMC products with production equipment for the manufacture of weapons of mass destruction (WMD) or any other weapon is strictly prohibited.
2. The exports of SMC products or technology from one country to another are governed by the relevant security laws and regulations of the countries involved in the transaction. Prior to the shipment of a SMC product to another country, assure that all local rules governing that export are known and followed.

Operation



Caution

1. Operation
The valve must be switched to each position instantly and securely. Stopping the handle between the extreme positions may cause malfunction.
2. Switch the valve by hand.
If a hammer or other tools are used, or it is operated mechanically through the use of a cylinder or the like, damage could result.

Mounting



Warning

1. If air leakage increases or the equipment does not operate properly, STOP operation.
After installation or repair, apply compressed air to the equipment and perform appropriate functional and leakage inspections to make sure the equipment is mounted properly.
2. Allow sufficient space for maintenance and inspection.
3. Install and operate the product only after reading the Operation Manual carefully and understanding its contents.
4. Warnings or specifications printed or labeled on the product should not be erased, removed or covered by any substance (i.e. paint).

Precautions for Design



Warning

1. Not suitable for use as a selector valve or a divider valve.
The valve can malfunction due to air leakage.
2. Not suitable for negative pressure.
The valve can malfunction due to air leakage.

Selection



Warning

1. Intermediate stop
When stopping the cylinder piston in the middle using the 3 position closed center valve, it is not possible to stop it correctly and precisely as the hydraulic equipment due to the air compressibility. Do not use this valve because it has slight air leakage and can not hold a stopping position. When it is necessary to hold a stopping position, select an equipment to prevent displacement and design the circuit.



Caution

1. Use in low temperature environments
The valve can be used at a temperature down to -5°C . Take appropriate measures to avoid freezing of drainage, moisture, etc.
2. Do not supply air pressure from other ports than port 1(P).
Air leakage may occur when the pressure is supplied from other ports.

Piping



Caution

1. Before piping
Before piping is connected, it should be thoroughly flushed with air or washed to remove chips, cutting oil and other debris from inside the pipe.
2. Pipe tape
When screwing piping or fittings into ports, ensure that chips from the pipe threads or sealing material do not enter the piping.
Also, if pipe tape is used, leave 1.5 to 2 thread ridges exposed at the end of the threads.

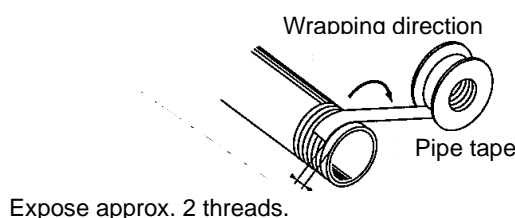

3. Tightening torque for fitting

When screwing a fitting into the valve, apply a spanner of the correct size to the spanner flats of the body after hand tightening and tighten it with a spanner for 2 to 3 rotations. Use the tightening torque shown in the table below as a guide.

Tightening torque for applicable piping

Thread	Appropriate tightening torque (Nm)
Rc 1/4	8 to 12
Rc 3/8	15 to 20
Rc 1/2	20 to 25
Rc 3/4	28 to 30
Rc 1	36 to 38

4. Ensure connection so that air is supplied to the port "1(P)".

Air leakage may occur when the pressure is supplied from other ports.

5. The products with additional symbol: -R, have the handle position rotated by 180°. The position of the handle and ports for the standard set up and -R is shown below.

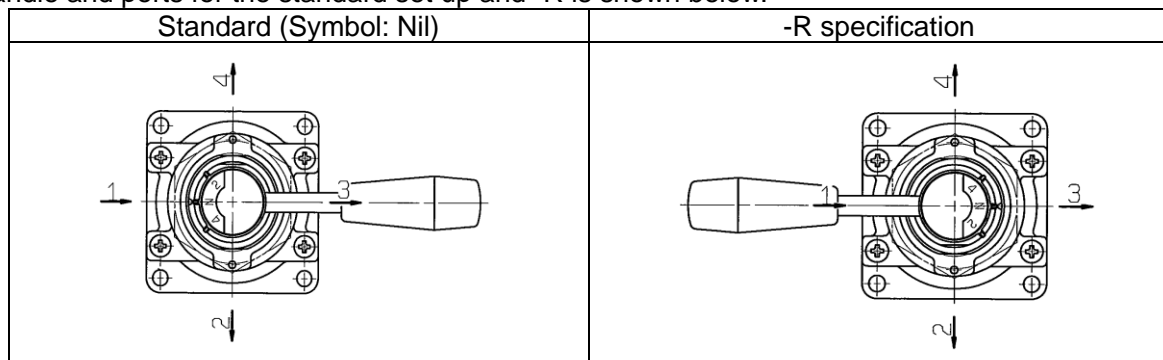

Lubrication

⚠ Caution

1. The product has been lubricated for life by the manufacturer, and does not require additional lubrication while in service.
2. If a lubricant is used in the system, use class 1 turbine oil (no additive), ISO VG32. Once lubricant is utilized within the system, since the original lubricant applied within the product during manufacturing will be washed away, please continue to supply lubrication to the system. Without continued lubrication, malfunctions could occur.

Air Supply

⚠ Warning

1. Use clean air.
Do not use compressed air that contains chemicals, synthetic oils including organic solvents, salt or corrosive gases, etc., as it can cause damage or malfunction of equipment.

⚠ Caution

1. Install an air filter.
Install an air filter upstream, near the valve.
Select an air filter with a filtration degree of 5µm or finer.
2. Take measure to ensure air quality, such as by installing an air dryer or aftercooler.
Compressed air that contains a large amount of condensate can cause malfunction of pneumatic equipment such as valves.
Therefore, take measure to ensure air quality, such as by installing an air dryer or aftercooler.
3. If excessive carbon powder is generated, eliminate it by installing a mist separator on the upstream side of valve.
If excessive carbon dust is generated by the compressor, it may adhere to the inside of a valve and cause it to malfunction.
For detailed information regarding the quality of the compressed air described above, refer to SMC's "Air Cleaning Systems".

Operating environment

Warning

1. Do not use in an environment where corrosive gases, chemicals, sea water, water or steam are present.
2. Do not use in potentially explosive environments.
3. Do not operate in a location subject to vibration or impact.
Please check the product specifications.
4. The valve should not be exposed to prolonged sunlight. Use a protective cover.
5. Shield the product from heat generated by nearby heat sources.
6. Employ suitable protective measures in locations where there is contact with water droplets, oil, welding spatter, etc.
7. When the valve is exposed to a large amount of dust, install a silencer into the port "3(R)".
When dust enters the valve from the port 3(R), it may cause air leakage.

Maintenance

Warning

Incorrect handling of the product may cause breakage or malfunction of the equipment or device.

1. Maintenance should be performed with attention to the following points.
2. Removal of equipment, and supply/exhaust of compressed air
When components are removed, first confirm that measures are in place to prevent workpiece from dropping and/or equipment running away, etc. Cut the supply pressure and exhaust all compressed air from the system.
For 3-position closed center, exhaust the residual pressure between the valve and the cylinder.
When the equipment is operated after remounting or replacement, first confirm that measures are in place to prevent lurching of actuators, etc. Then, confirm that the equipment is operating normally.

Caution

1. Draining
Remove drainage from air filters regularly.
2. Lubrication
Once lubrication has been started, it must be continued.
Apply class 1 turbine oil (ISO VG32) as a lubricant.
Use of other lubricants may cause malfunction.

2. Application

This product is designed to operate an air cylinder.

3. Specifications

Standard specifications

Model	VH200	VH300	VH400	VH600
Port size	1/4	1/4, 3/8	1/4, 3/8, 1/2, 3/4	3/4, 1
Fluid	Air			
Proof pressure (MPa)	1.5			
Max. operating pressure (MPa)	1.0			0.7
Ambient and operating fluid temperature (°C)	-5 to 60°C (No freezing)			
Total leakage (cm ³ /min)	20 or less	30 or less	50 or less	500 or less
Weight (kg)	0.42	0.71	1.28	9.7

4. How to Order

VH 2 0 1 — F 02 — R —

Hand valve

Body size (Base size)	
2	1/4 base
3	3/8 base
4	1/2 base
6	1 base

Thread type	
Nil	Rc
N	NPT
F	G

Made to Order	
Nil	Standard
X116	Handle (Red)

Symbol	Description	Body size			
		VH2	VH3	VH4	VH6
Nil	Standard	●	●	●	●
L	Long handle	-	●	●	-
R	Handle position 180° change	●	●	●	●

* When specifying more than one option, indicate symbols alphabetically.
 * Note that 1(P) port of VH600 is located on handle side as standard.

Port size (nominal size)		Body size			
		VH2	VH3	VH4	VH6
02	1/4	●	●	●	-
03	3/8	-	●	●	-
04	1/2	-	-	●	-
06	3/4	-	-	●	●
10	1	-	-	-	●

Switching method	JIS symbol								
		<table border="1"> <tr> <td>0</td> <td>3 position closed center</td> <td></td> </tr> <tr> <td>1</td> <td>3 position exhaust center</td> <td></td> </tr> <tr> <td>2</td> <td>2 position</td> <td></td> </tr> </table>	0	3 position closed center		1	3 position exhaust center		2
0	3 position closed center								
1	3 position exhaust center								
2	2 position								

Piping / Mounting					
Symbol	Mounting method	Piping <small>(Note)</small>			
		VH2	VH3	VH4	VH6
0	Body				
1	Panel mount				—
2	Body				—
3	Panel mount				—
4	Body		—	—	—
5	Panel mount		—	—	—

Note: The port 3(R) of the VH600 is located on the bottom only.

5. Construction / Parts list

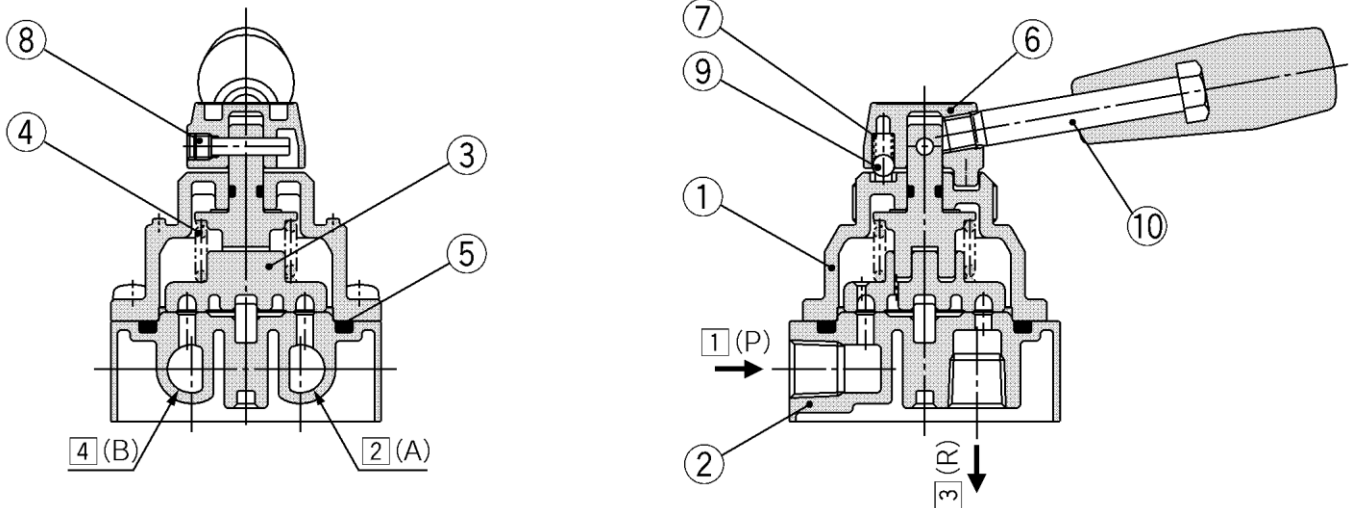

Component Parts

No.	Description	Material	
		VH200 / 300 / 400	VH600
1	Cover	Zinc die-casted	Cast iron
2	Body	Aluminum die-casted	Cast iron

Replacement Parts

Description	No.	Component parts	Material	Part No.		
				VH200	VH300	VH400
Maintenance and repair kit*	3	Slide ring	Resin	KT-VH2***-N	KT-VH3***-N	KT-VH4***-N
	4	Slide ring spring	Piano wire			
	5	O-ring	NBR			
Handle head assembly*	6	Handle head	Zinc alloy	24403A	24413A	24413A
	7	Spring	Piano wire			
	8	Pin	Structural steel			
	9	Steel ball	SUJ			
Handle head assembly*	6	Handle head	Zinc alloy	244036A	244125A	244125A
	7	Spring	Piano wire			
	8	Pin	Structural steel			
	9	Steel ball	SUJ			
Handle	10	Standard	—	244032	244032	244032
		Long type		-	244127	244223
		Red		244035	244035	244035

NOTE: Replacement parts for the VH600 series are not available.

* Including grease.

Revision history

D: Product numbers added.

E: Updated formats and How to Order.

SMC Corporation

Tel: + 81 3 5207 8249 Fax: +81 3 5298 5362

URL <https://www.smcworld.com>

Note: Specifications are subject to change without prior notice and any obligation on the part of the manufacturer.
© SMC Corporation All Rights Reserved