



# Operation Manual

PRODUCT NAME

Solenoid Valve

MODEL / Series / Product Number

VF1000/3000/5000 Series  
(PILOT VALVE: V200)

**SMC Corporation**

# Contents

Safety Instructions	2,3
Precautions on Design/Selection	4,5
Mounting	6
Piping	6
Wiring	7
Lubrication	7
Air Supply	7
Operating Environment	8
Maintenance	8
Specific Product Precautions	9 to 13
Trouble shooting	14
Remedy	15



# Safety Instructions

These safety instructions are intended to prevent hazardous situations and/or equipment damage. These instructions indicate the level of potential hazard with the labels of “**Caution**,” “**Warning**” or “**Danger**.” They are all important notes for safety and must be followed in addition to International Standards (ISO/IEC)<sup>\*1)</sup>, and other safety regulations.

\*1) ISO 4414: Pneumatic fluid power - General rules and safety requirements for systems and their components  
ISO 4413: Hydraulic fluid power - General rules and safety requirements for systems and their components  
IEC 60204-1: Safety of machinery - Electrical equipment of machines - Part 1: General requirements  
ISO 10218-1: Robots and robotic devices - Safety requirements for industrial robots - Part 1: Robots  
etc.



## **Danger**

**Danger** indicates a hazard with a high level of risk which, if not avoided, will result in death or serious injury.



## **Warning**

**Warning** indicates a hazard with a medium level of risk which, if not avoided, could result in death or serious injury.



## **Caution**

**Caution** indicates a hazard with a low level of risk which, if not avoided, could result in minor or moderate injury.

## **Warning**

### **1. The compatibility of the product is the responsibility of the person who designs the equipment or decides its specifications.**

Since the product specified here is used under various operating conditions, its compatibility with specific equipment must be decided by the person who designs the equipment or decides its specifications based on necessary analysis and test results. The expected performance and safety assurance of the equipment will be the responsibility of the person who has determined its compatibility with the product. This person should also continuously review all specifications of the product referring to its latest catalog information, with a view to giving due consideration to any possibility of equipment failure when configuring the equipment.

### **2. Only personnel with appropriate training should operate machinery and equipment.**

The product specified here may become unsafe if handled incorrectly. The assembly, operation and maintenance of machines or equipment including our products must be performed by an operator who is appropriately trained and experienced.

### **3. Do not service or attempt to remove product and machinery/equipment until safety is confirmed.**

1. The inspection and maintenance of machinery/equipment should only be performed after measures to prevent falling or runaway of the driven objects have been confirmed.
2. When the product is to be removed, confirm that the safety measures as mentioned above are implemented and the power from any appropriate source is cut, and read and understand the specific product precautions of all relevant products carefully.
3. Before machinery/equipment is restarted, take measures to prevent unexpected operation and malfunction.

### **4. SMC products cannot be used beyond their specifications. They are not developed, designed, and manufactured to be used under the following conditions or environments. Use under such conditions or environments is not allowed.**

1. Conditions and environments outside of the given specifications, or use outdoors or in a place exposed to direct sunlight.
2. Use for nuclear power, railways, aviation, space equipment, ships, vehicles, military application, equipment affecting human life, body, and property, combustion equipment, entertainment equipment, emergency shut-off circuits, press clutches, brake circuits, safety equipment, etc., and use for applications that do not conform to standard specifications such as catalogs and operation manuals.
3. Use for interlock circuits, except for use with double interlock such as installing a mechanical protection function in case of failure. Please periodically inspect the product to confirm that the product is operating properly.



# Safety Instructions

## Caution

**SMC develops, designs, and manufactures products to be used for automatic control equipment, and provides them for peaceful use in manufacturing industries.**

**Use in non-manufacturing industries is not allowed.**

Products SMC manufactures and sells cannot be used for the purpose of transactions or certification specified in the Measurement Act of each country.

The new Measurement Act prohibits use of any unit other than SI units in Japan.

## Limited warranty and Disclaimer/Compliance Requirements

The product used is subject to the following “Limited warranty and Disclaimer” and “Compliance Requirements”. Read and accept them before using the product.

### Limited warranty and Disclaimer

1. The warranty period of the product is 1 year in service or 1.5 years after the product is delivered, whichever is first.\*2)  
Also, the product may have specified durability, running distance or replacement parts. Please consult your nearest sales branch.
2. For any failure or damage reported within the warranty period which is clearly our responsibility, a replacement product or necessary parts will be provided.  
This limited warranty applies only to our product independently, and not to any other damage incurred due to the failure of the product.
3. Prior to using SMC products, please read and understand the warranty terms and disclaimers noted in the specified catalog for the particular products.

**\*2) Vacuum pads are excluded from this 1 year warranty.**

A vacuum pad is a consumable part, so it is warranted for a year after it is delivered.

Also, even within the warranty period, the wear of a product due to the use of the vacuum pad or failure due to the deterioration of rubber material are not covered by the limited warranty

### Compliance Requirements

1. The use of SMC products with production equipment for the manufacture of weapons of mass destruction (WMD) or any other weapon is strictly prohibited.
2. The exports of SMC products or technology from one country to another are governed by the relevant security laws and regulations of the countries involved in the transaction. Prior to the shipment of a SMC product to another country, assure that all local rules governing that export are known and followed.



## Precautions for 5 Port Solenoid Valve ①

Be sure to read before handling. Refer to main text for detailed precautions on every series.

### Design / Selection

#### Warning

##### 1. Confirm the specifications

Products represented in this instruction manual are designed only for use in compressed air systems (including vacuum). Do not operate at pressures or temperatures, etc., beyond the range of specifications, as this can cause damage or malfunction.

We do not guarantee against any damage if the product is used outside of the specification range.

##### 2. Actuator drive

When an actuator, such as a cylinder, is to be driven using a valve, take appropriate measures (cover installation or approach prohibition) to prevent potential danger caused by actuator operation.

##### 3. Intermediate stops

For 3-position closed center type, it is difficult to make a piston stop at the required position accurately due to the compressibility of air.

Furthermore, since valves and cylinders are not guaranteed for zero air leakage, it may not be possible to hold a stopped position for an extended period of time.

##### 4. Effect of back pressure when using a manifold.

Use caution when valves are used on a manifold, because an actuator may malfunction due to back-pressure. For 3-position exhaust center valve or single acting cylinder, take appropriate measures to prevent the malfunction by using it with an individual EXH spacer assembly.

##### 5. Holding pressure (including vacuum).

Since the valve are subject to air leakage, they cannot be used for applications such as holding pressure (including vacuum) in a pressure vessel.

##### 6. Not suitable for use as an emergency shut-off valve, etc.

The valves listed in this instruction manual are not designed for safety applications such as an emergency shutoff valve. If the valves are used for the mentioned applications, additional safety measures should be adopted.

##### 7. Release of residual pressure

For maintenance purposes install a system for releasing residual pressure. Especially in the case of 3-position closed center valve type, ensure that the residual pressure between the valve and the cylinder is released.

##### 8. Ventilation

Provide ventilation when using a valve in a confined area, such as in a closed control panel. For example, install a ventilation opening, etc. in order to prevent pressure from increasing inside of the confined area and to release the heat generated by the valve.

##### 9. Double solenoid type

When using the double solenoid type for the first time, actuators may travel in an unexpected direction depending on the switching position of the valve.

Implement measures to prevent any danger from occurring when operating the actuator.

##### 10. Extended periods of continuous energization

If a valve will be continuously energized for an extended period of time, the temperature of the valve will increase due to the heat generated by the coil. This will likely adversely affect the performance of the solenoid valve and any nearby peripheral equipment. Therefore, when it is continuously energized or the energized period per day is longer than the de-energized period use either: DC specification, power-saving type.

##### 11. Do not disassemble the product or make any modifications, including additional machining.

Doing so may cause human injury and/or an accident.

##### 12. Resumption after a long period of holding time

When resuming operation after a long period of holding time, there are cases in which, regardless of whether the product is in an ON or OFF state, there is a delay in the initial response time due to adhesion. Conducting several cycles of running-in operation will solve this problem. Please consider implementing this before resumption.

#### Caution

##### 1. Momentary energization

If a double solenoid valve is operated with momentary energization, it should be energized for at least 0.1 second. However, depending on the condition of the secondary load, it should be energized until the cylinder reaches the stroke end position, since there is a possibility of malfunction.

##### 2. Leakage voltage

Take note that the leakage voltage will increase when a resistor is used in parallel with switching element or a C-R circuit (surge voltage suppressor) is used for protecting a switching device because of the passing leakage voltage through the C-R circuit.

The suppressor residual leakage voltage should be as follows.

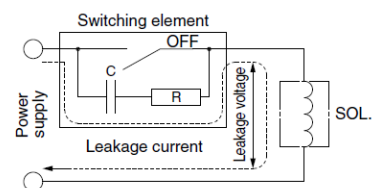

##### DC coil

Should be 3% or less of the rated voltage.

##### AC coil

Should be 8% or less of the rated voltage.



## Precautions for 5 Port Solenoid Valve ②

Be sure to read before handling. Refer to main text for detailed precautions on every series.

## Design / Selection

**⚠ Caution****3. Valves with a power-saving circuit (PWM circuit built-in type)**

Valves with a power-saving circuit (PWM circuit built-in type) perform the high-speed switching operation with the PWM control circuit inside the valve after the rated power has been applied for several tens of ms to reduce the power consumption. The problems shown below may occur in this type of valve due to the switch or drive circuit system by the PWM control. Be sure to check the operation with the customer's machine sufficiently when selecting the product.

## 1) The valve does not turn ON.

1. If the PWM circuit built-in type valve is driven by a mechanical relay, etc., and chattering occurs during the several tens of ms necessary for the valve to reach its rated voltage, the valve may not turn ON correctly.

2. If a filter, etc., is connected between the power supply and the PWM circuit built-in type valve, the current necessary to drive the valve lowers due to the effects of the filter, and then the valve may not turn ON correctly.

## 2) The valve does not turn OFF.

If the PWM circuit built-in type valve is driven by the photo coupler, the photo coupler cannot turn OFF and the valve is kept in an ON state. Therefore, take great care when using the photo coupler built-in SSR (solid state relay) or drive circuit.

**4. Solenoid valve drive for AC with solid state output (SSR, TRIAC output, etc.)**

## 1) Current leakage

When using a snubber circuit (C-R element) for surge protection of the output, a very small amount of electrical current will continue to flow even during the OFF state. This results in the valve not returning. In the a situation where the tolerance is exceeded, as in the above case, take measures to install a bleeder resistor.

## 2) Minimum allowable load amount (Min. load current)

When the consumption current of a valve is less than the output's minimum allowable load volume or the margin is small, the output may not switch normally.

## 3) Solenoid valve with full wave rectifier circuit

When the solenoid valve built-in full wave rectifier circuit with AC specifications is used, a return failure of the solenoid valve may occur depending on the kind of triac output circuit. Carefully check this point when selecting a SSR or sequencer. For details, contact the SSR or sequencer manufacturer.

**5. Surge voltage suppressor**

1) The surge voltage suppressor built into the valve is intended to protect the output contacts so that the surge generated inside valve does not adversely affect the output contacts. Therefore, if an overvoltage or overcurrent is received from an external peripheral device, the surge voltage protection element inside the valve is overloaded, causing the element to break. In the worst case, the breakage causes the electric circuit to enter short-circuit status. If energizing continues while in this state, a large current flows. This may cause secondary damage to the output circuit, external peripheral device, or valve, and may also cause a fire. So, take appropriate protective measures, such as the installation of an overcurrent protection circuit in the power supply or a drive circuit to maintain a sufficient level of safety.

2) If a surge protection circuit contains nonstandard diodes, such as Zener diodes or varistor, a residual voltage that is in proportion to the protective circuit and the rated voltage will remain. Therefore, take into consideration the surge voltage protection of the controller. In the case of diodes, the residual voltage is approximately 1V.

**6. Surge voltage intrusion**

With non-polar type solenoid valves, at times of sudden interruption of the loading power supply, such as emergency shutdown, surge voltage intrusion may be generated from loading equipment with a large capacity (power consumption), and the solenoid valve in a de-energized state may switch over (see Figure 1).

When installing a breaker circuit for the loading power supply, consider using a solenoid valve with polarity (with polarity protection diode), or install a surge absorption diode between the loading equipment COM line and the output equipment COM line (see Figure 2).

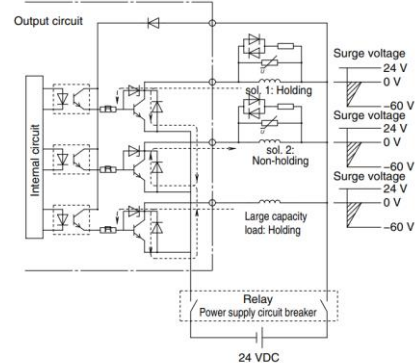

Figure 1. Surge intrusion circuit example (NPN outlet example)

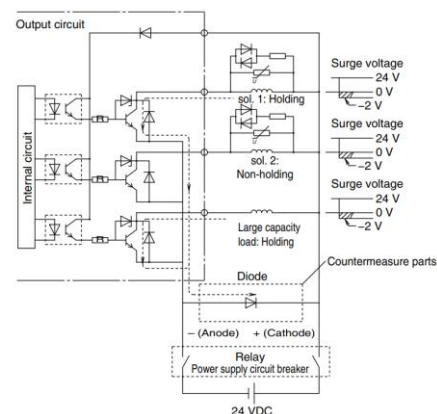

Figure 2. Surge intrusion countermeasure example (NPN outlet example)

**7. Operation in a low temperature condition**

It is possible to operate a valve in extreme temperature, as low as -10 °C. Take appropriate measures to avoid freezing of drainage, moisture etc. in low temperatures.

**8. Mounting orientation**

Mounting orientation is free.

**9. Initial lubrication of main valve**

The initial lubricant (grease) has already been applied to the main valve.

There are some standard valve products (HF1-series) that use fluorine grease for food processing equipment (NSF H-1).

**10. For the pilot EXH (PE) port**

If the solenoid valve and the manifold's pilot EXH (PE) port is restricted extremely or blocked, abnormal operation of the solenoid valve may occur.



## Precautions for 5 Port Solenoid Valve ③

Be sure to read before handling. Refer to main text for detailed precautions on every series.

### Mounting

#### ⚠ Warning

##### 1. Operation manual

Install the products and operate them only after reading the operation manual carefully and understanding its contents. Also, keep the manual where it can be referred to as necessary.

##### 2. Ensure sufficient space for maintenance activities.

When installing the products, allow access for maintenance.

##### 3. Tighten threads with the proper tightening torque.

When installing the products, follow the listed torque specifications.

##### 4. If air leakage increases or equipment does not operated properly, stop operation.

Check mounting conditions when air and power supplies are connected. Initial function and leakage tests should be performed after installation.

##### 5. Painting and coating

Warnings or specifications printed or affixed to the product should not be erased, removed or covered up.

Also, applying paint to resinous parts may have an adverse effect due to the solvent in the paint.

### Piping

#### ⚠ Caution

##### 1. Refer to the Fittings and Tubing Precautions for handling one-touch fittings.

##### 2. Preparation before piping

Before piping is connected, it should be thoroughly blown out with air (flushing) or washed to remove chips, cutting oil and other debris from inside the pipe.

##### 3. Wrapping of pipe tape

When screwing piping or fittings into ports, ensure that chips from the pipe threads or sealing material do not enter the piping. Also, if pipe tape is used, leave 1 thread ridges exposed at the end of the threads.

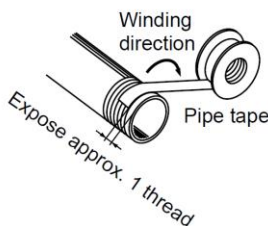

##### 4. Closed center

For closed center, check the piping to prevent air leakage from the piping between the valve and the cylinder.

##### 5. Connection of piping and fittings

When screwing piping or fittings into the valve, tighten them as follows.

- 1) When using SMC's M3, M5 fittings, follow the procedures below to tighten them.

##### • Connection thread: M3

First, tighten by hand, then use a suitable wrench to tighten the hexagonal portion of the body an additional 1/4 turn. The reference value for the tightening torque is 0.4 to 0.5 N·m.

##### • Connection thread: M5

First, tighten by hand, then use a suitable wrench to tighten the hexagonal portion of the body an additional 1/6 to 1/4 turn. The reference value for the tightening torque is 1 to 1.5 N·m.

\*Excessive tightening may damage the thread portion or deform the gasket and cause air leakage. Insufficient tightening may loosen the threads or cause air leakage.

##### • When using a fitting other than an SMC fitting, follow the instructions given by the fitting manufacturer.

- 2) For a fitting with sealant R or NPT, first, tighten it by hand, then use a suitable wrench to tighten the hexagonal portion of the body an additional two or three turns. For the tightening torque, refer to the table below.

Connection thread size	Proper tightening torque (N·m)
1/8	3 to 5
1/4	8 to 12
3/8	15 to 20
1/2	20 to 25

- 3) If the fitting is tightened with excessive torque, a large amount of sealant will seep out. Remove the excess sealant.

- 4) Insufficient tightening may cause seal failure or loosen the threads.

- 5) For reuse

(1) Normally, fittings with a sealant can be reused up to 2 to 3 times.

(2) To prevent air leakage through the sealant, remove any loose sealant stuck to the fitting by blowing air over the threaded portion.

(3) If the sealant no longer provides effective sealing, wind sealing tape over the sealant before reusing. Do not use any form of sealant other than the tape type of sealant.

(4) Once the fitting has been tightened, backing it out to its original position often causes the sealant to become defective. Air leakage will occur.

##### 6. Piping to products

When piping to a product, avoid mistakes regarding the supply port, etc.



## Precautions for 5 Port Solenoid Valve ④

Be sure to read before handling. Refer to main text for detailed precautions on every series.

### Wiring

#### Warning

1. **The solenoid valve is an electrical product.**  
For safety, install an appropriate fuse and circuit breaker before use.

#### Caution

##### 1. Polarity

When connecting power to a solenoid valve with a DC specification and equipped with a light or surge voltage suppressor, check for polarity. If there is polarity, take note of the following.

##### **Without diode to protect polarity.**

If a mistake is made regarding the polarity, damage may occur to the diode in the valve, the switching element in a control device or power supply equipment, etc.

##### **With diode to protect polarity.**

If polarity connection is wrong, the valve does not operate.

##### 2. Applied voltage

When electric power is connected to a solenoid valve, be careful to apply the proper voltage. Improper voltage may cause malfunction or coil damage.

##### 3. Check the connections.

Check if the connections are correct after completing all wiring.

##### 4. External force applied to the lead wire

If an excessive force is applied to the lead wire, this may cause faulty wiring. Take appropriate measures so that a force of 30 N or more is not applied to the lead wire.

When instructions are given in the Specific Product Precautions, follow these specifications.

### Lubrication

#### Warning

##### 1. Lubrication

1) The valve has been lubricated for life by the factory and does not require any further.

2) If a lubricant is used in the system, use class 1 (no additives) and class 2 (with additives) ISO VG32 turbine oil. For details about lubricant manufacturers' brands, refer to the SMC website.

Once a lubricant is used in the system, lubrication must be continued because the original lubricant applied during manufacturing will be washed away.

If turbine oil is used, refer to the Safety Data Sheet (SDS) of the oil.

##### 2. Lubrication amount

If the lubrication amount is excessive, the oil may accumulate inside the pilot valve, causing malfunction or response delay. So, do not apply a large amount of oil. When a large amount of oil needs to be applied, use an external pilot type to put the supply air on the pilot valve side in the non-lube state. This prevents the accumulation of oil inside the pilot valve.

### Air Supply

#### Warning

##### 1. Type of fluids

Be sure to use compressed air for the fluid.

##### 2. When there is a large amount of drainage.

Compressed air containing a large amount of drainage can cause malfunction of pneumatic equipment. An air dryer or water separator should be installed upstream from filters.

##### 3. Drain flushing

If condensation in the drain bowl is not emptied on a regular basis, the bowl will overflow and allow the condensation to enter the compressed air lines. It causes malfunction of pneumatic equipment. If the drain bowl is difficult to check and remove, installation of a drain bowl with an auto drain option is recommended.

For compressed air quality, refer to SMC's Best Pneumatics catalog.

##### 4. Use clean air

Do not use compressed air that contains chemicals, synthetic oils including organic solvents, salt or corrosive gasses, etc., as it can cause damage or malfunction.

#### Caution

1. **When low dew point air is used as the fluid, degradation of the lubrication properties inside the equipment may occur, resulting in reduced reliability (or reduced service life) of the equipment. Consider using products compatible with low dew points such as those from the 25A- series.**

2. **Install an air filter.**

Install an air filter upstream near the valve. Select an air filter with a filtration size of 5 μm or smaller.

3. **Take measures to ensure air quality, such as by installing an aftercooler, air dryer, or water separator.**

Compressed air that contains a large amount of drainage can cause malfunction of pneumatic equipment such as valves. Therefore, take appropriate measures to ensure air quality, such as by providing an aftercooler, air dryer, or water separator.

4. **If excessive carbon powder is seen, install a mist separator on the upstream side of the valve.**

If excessive carbon dust is generated by the compressor, it may adhere to the inside of a valve and cause it to malfunction. For compressed air quality, refer to SMC's Best Pneumatics catalog.





## Precautions for 5 Port Solenoid Valve ⑤

Be sure to read before handling. Refer to main text for detailed precautions on every series.

### Operating Environment

#### Warning

1. Do not use in an atmosphere having corrosive gases, chemicals, sea water, water, water steam, or where there is direct contact with any of these.
2. Products with IP65 enclosures (based on IEC60529) are protected against dust and water, however, these products cannot be used in water.
3. Products compliant to IP65 satisfy the specifications through mounting. Be sure to read the Precautions for each product.
4. Do not use in an environment where flammable gas or explosive gas exists. Usage may cause a fire or explosion. The products do not have an explosion proof construction.
5. Do not use in a place subject to heavy vibration and/or shock.
6. The valve should not be exposed to prolonged sunlight. Use a protective cover.
7. Remove any sources of excessive heat.
8. If it is used in an environment where there is possible contact with oil, weld spatter, etc., exercise preventive measures.
9. When the valve is mounted in a control panel or it's energized for a long time, make sure ambient temperatures is within the specification of the valve.

#### Caution

##### 1. Temperature of ambient environment

Use the valve within the range of the ambient temperature specification of each valve. In addition, pay attention when using the valve in environments where the temperature changes drastically.

##### 2. Humidity of ambient environment

- When using the valve in environments with low humidity, take measures to prevent static.
- If the humidity rises, take measures to prevent the adhesion of water droplets on the valve.

### Maintenance

#### Warning

##### 1. Perform maintenance inspection according to the procedures indicated in the operation manual.

If handled improperly, malfunction and damage of machinery or equipment may occur.

##### 2. Removal of equipment, and supply/exhaust of compressed air

When components are removed, first confirm that measures are in place to prevent workpieces from dropping, run-away equipment, etc. Then, cut off the supply pressure and electric power, and exhaust all compressed air from the system using the residual pressure release function.

For 3-position closed center type, exhaust the residual pressure between the valve and the cylinder. When the equipment is operated after remounting or replacement, first confirm that measures are in place to prevent lurching of actuators, etc. Then, confirm that the equipment is operating normally.

##### 3. Low frequency operation

Valves should be operated at least once every 30 days to prevent malfunction. (Use caution regarding the air supply.)

##### 4. Manual override operation

When the manual override is operated, connected equipment will be actuated.

Operate after safety is confirmed.

##### 5. If the volume of air leakage increases or the valve does not operate normally, do not use the valve.

**Perform periodic maintenance on the valve to confirm the operating condition and check for any air leakage.**

#### Caution

##### 1. Drain flushing

Remove drainage from the air filters regularly.

##### 2. Lubrication

In the case of rubber seals, once lubrication has been started, it must be continued.

Use class 1 (no additives) and class 2 (with additives) ISO VG32 turbine oil. For details about lubricant manufacturers' brands, refer to the SMC website. If other lubricant oil is used, it may cause a malfunction.

##### 3. Manual override operation

When switching a double solenoid valve via the manual override operation, instantaneous operation may cause the malfunction of the cylinder. It is recommended that the manual override be held until the cylinder reaches the stroke end position.

**Manual Override****⚠ Warning**

Without an electric signal for the solenoid valve the manual override is used for switching the main valve. Connected actuator is started by manual operation. Use the manual override after confirming that there is no danger.

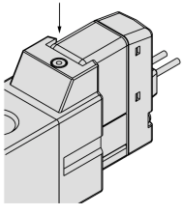
**■ Non-locking push type**

Push down on the manual override button with a small screwdriver until it stops.  
Release the screwdriver and the manual override will return.

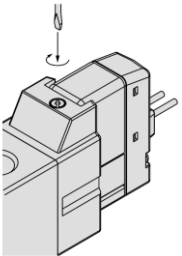
**■ Push-turn locking slotted type**

Locked condition

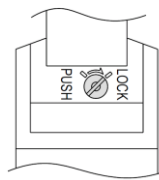

Push down on the manual override with a small flat head screwdriver until it stops. Turn it clockwise by 90° to lock it. Turn it counterclockwise to release it.

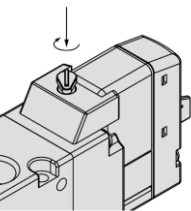
**■ Push-turn locking lever type**

Locked condition

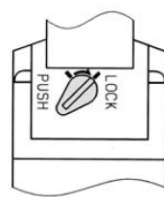

After pushing down, turn in the direction of the arrow. If it is not turned, it can be operated the same way as the non-locking type.

**⚠ Caution**

When locking the manual override with the push-turn locking type (D or E type), be sure to push it down before turning. Turning without first pushing it down can cause damage to the manual override and other trouble such as air leakage, etc. Do not apply excessive torque when turning the locking type manual override. (0.1N·m)

**How to Use L/M-Type Plug Connector****⚠ Caution****1. Attaching and detaching connectors**

- To attach a connector, hold the lever and connector unit between your fingers and insert straight onto the pins of the solenoid valve so that the lever's pawl is pushed into the groove and locks.
- To detach a connector, remove the pawl from the groove by pushing the lever downward with your thumb, and pull the connector straight out.

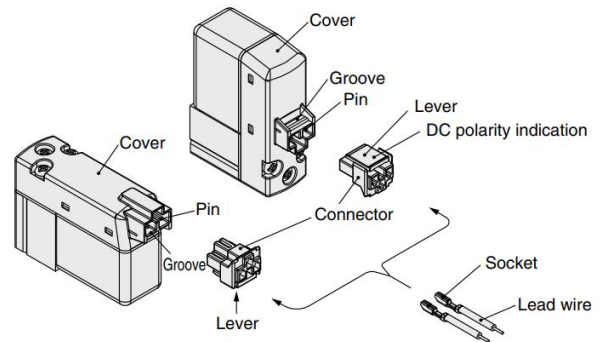
**2. Crimping lead wires and sockets**

Not necessary if ordering the lead wire pre-connected model. Strip 3.2 to 3.7mm at the end of the lead wires, insert the ends of the core wires evenly into the sockets, and then crimp with a crimping tool. When this is done, take care that the coverings of the lead wires do not enter the core wire crimping area.

(Crimping tool: F1-706412 by Minebea Connect Inc.)

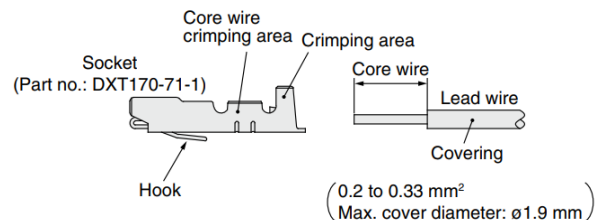
**3. Attaching and detaching sockets with lead wire****• Attaching**

Insert the sockets into the square holes of the connector (⊕, ⊖ indication), and continue to push the sockets all the way in until they lock by hooking into the seats in the connector. (When they are pushed in, their hooks open and they are locked automatically.) Then, confirm that are locked by pulling lightly on the lead wires.



## VF1000/3000/5000 Series

# Specific Product Precautions 2

Be sure to read before handling.

### How to Use L/M-Type Plug Connector

#### ⚠ Caution

##### • Detaching

To detach a socket from a connector, pull out the lead wire while pressing the socket's hook with a stick having a thin tip (approx.1mm). If the socket will be used again, first spread the hook outward.

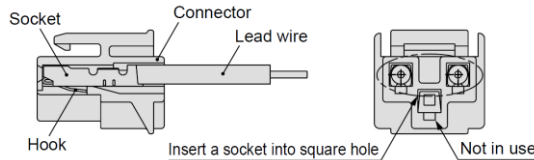

### How to Use DIN Terminal

The DIN terminal type with an IP65 enclosure is protected against dust and water, however, it must not be used in water.

#### ⚠ Caution

##### Connection

- 1) Loosen the set screw and pull the connector out of the solenoid valve terminal block.
- 2) After removing the set screw, insert a flat head screwdriver, etc. into the notch on the bottom of the terminal block and pry it open, separating the terminal block and the housing.
- 3) Loosen the terminal screws on the terminal block, insert the core of the lead wire into the terminal, and attach securely with the terminal screws.
- 4) In addition, when using the DC mode type with a surge voltage suppressor (polar: S and Z types), connect wires corresponding to the polarity (+ or -) that is printed on the terminal block.
- 5) Tighten the ground nut to secure the wire. In the case of connecting wires, select cable cords carefully because if those out of the specified range ( $\phi 4.5$  to  $\phi 7$ ) are used, it will not be able to satisfy IP65 (enclosure). Tighten the ground nut and set screw within the specified range of torque.

##### Changing the entry direction

After separating terminal block and housing, the cord entry direction can be changed by attaching the housing in the opposite direction.

\*Make sure not to damage elements, etc., with the lead wires of the cord.

##### Precautions

Plug in and pull out the connector vertically without tilting to one side.

##### Applicable cable

Cable O.D.: 4.5 to 7

(Reference) 0.5 mm<sup>2</sup> to 1.5mm<sup>2</sup>, 2-core or 3-core, equivalent to JIS C 3306

##### Applicable crimped terminal

O terminal: R1.25-4M that is specified in JIS C 2805

Y terminal: 1.25-3L, which is released by JST Mfg.Co.,Ltd

Stick terminal: Size 1.5 or shorter.

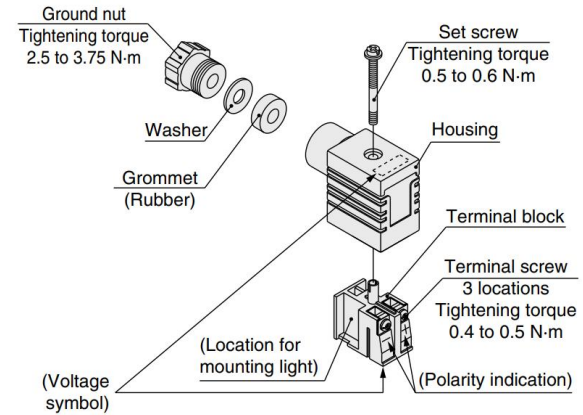

### DIN (EN175301-803) Terminal

Y type DIN terminal corresponds to the DIN connector with terminal pitch 10mm, which complies with EN175301-803B, Since the terminal pitch is different from the D type DIN connector, these two types are not interchangeable.

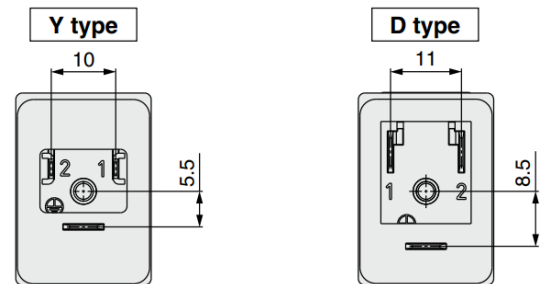

#### Circuit with indicator light (Built-in connector)

##### DC (□Z) circuit diagram

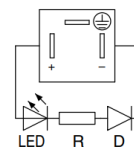

LED: Light emitting diode  
D: Protective diode  
R: Resistor

##### AC (□Z) circuit diagram

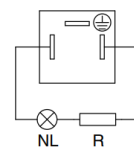

NL: Neon light, R: Resistor

##### DC (□U) circuit diagram

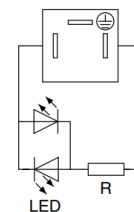

LED: Light emitting diode  
R: Resistor

Note) The 24 VAC specification is the same as those in the DC (□U) circuit diagram.



## VF1000/3000/5000 Series

# Specific Product Precautions 3

Be sure to read before handling.

### How to Use Conduit Terminal

#### ⚠ Caution

##### Connection

- 1) Loosen the set screw and remove the terminal block cover from the terminal block.
- 2) Loosen the terminal screws on the terminal block, insert the core of the lead wire or crimped terminal into the terminal, and attach securely with the terminal screws.



In addition, when using the DC mode type with a surge voltage suppressor (polar: S and Z types), connect wires to terminal 1 and 2 corresponding to the polarity (+ or -) as shown on the right figure.

- 3) Secure the cord by fastening the ground nut.

In the case of connecting wires, select cable cords carefully because if those out of the specified range ( $\phi 4.5$  to  $\phi 7$ ) are used, it will not be able to satisfy IP65 (enclosure). Tighten the Ground nut and set screw within the specified range of torque.

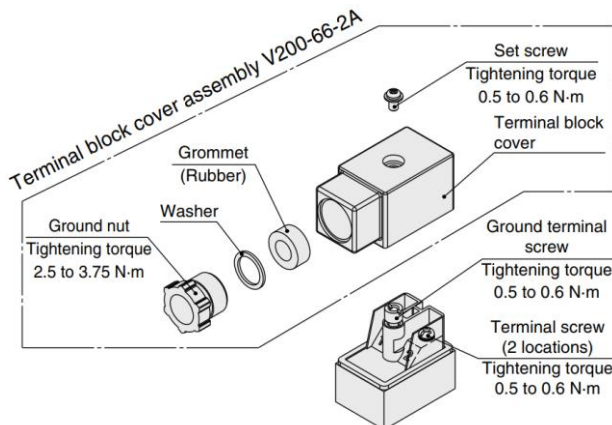

##### Applicable cable

Cable O.D.:  $\phi 4.5$  to  $\phi 7$

(Reference)  $0.5 \text{ mm}^2$  to  $1.5 \text{ mm}^2$ , 2-core or 3-core, equivalent to JIS C 3306

##### Applicable crimped terminal

O terminal: Equivalent to R1.25-3 that is specified in JIS C 2805

Y terminal: Equivalent to 1.25-3, which is released by JST

Mfg.Co.,Ltd

\*Use O terminal when a ground terminal is used.

### Light/Surge Voltage Suppressor

#### ⚠ Caution

<DC>

##### ■ Polar type

With surge voltage suppressor (□S)

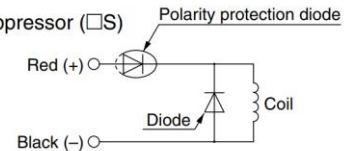

##### ● Grommet or L/M-type plug connector

With light/surge voltage suppressor (□Z)

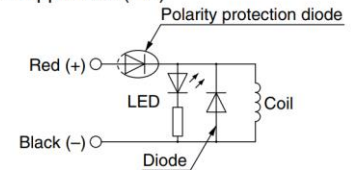

##### ● DIN or Conduit terminal

With light/surge voltage suppressor (□Z)

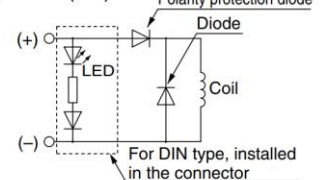

##### ■ Non-polar type

With surge voltage suppressor (□R)

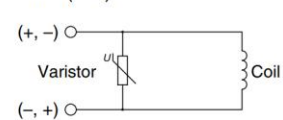

##### ● Grommet or L/M-type plug connector

With light/surge voltage suppressor (□U)

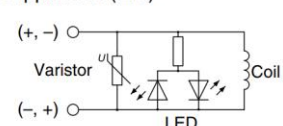

##### ● DIN or Conduit terminal

With light/surge voltage suppressor (□U)

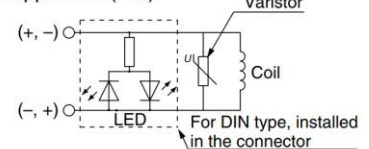

#### ⚠ Caution

- Please connect correctly the lead wires to + (positive) and - (negative) indications on the connector. (For non-polar type, the lead wires can be connected to either one.)
- When the valve with polarity protection diode is used, the voltage will drop by approx. 1V. Therefore, pay attention to the allowable voltage fluctuation (For details, refer to the solenoid specifications of each type of valve).
- Solenoids, whose lead wires have been pre-wired: + (positive) side red and - (negative) side black.



Be sure to read before handling.

## Light/Surge Voltage Suppressor

### ■ With power saving circuit

Power consumption is decreased by approx. 1/3 by reducing the wattage required to hold the valve in an energized state. (Effective energizing time is over 40ms at 24 VDC.) Refer to the electrical power waveform as shown below.

#### <Electrical power waveform of energy saving type>

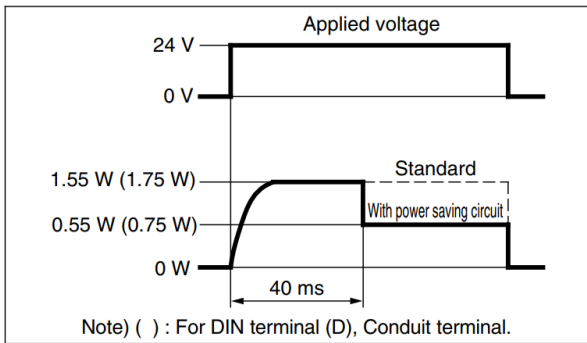

- Since the voltage will drop by approx. 0.5V due to the transistor, pay attention to the allowable voltage fluctuation. (For details, refer to the solenoid specifications of each type of valve.)

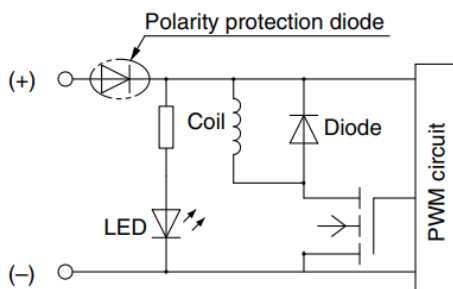

### <AC>

There is no S option, since a rectifier prevents surge voltage generation.

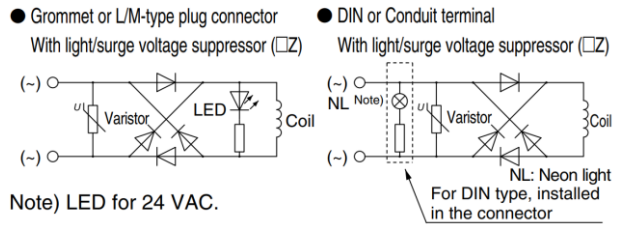

### Residual voltage of the surge voltage suppressor

Note) If a varistor or diode surge voltage suppressor is used, there is some residual voltage to the protection element and rated voltage. Therefore, refer to the table below and pay attention to the surge voltage protection on the controller side. Also, since the response time dose change, refer to the specifications.

#### Residual Voltage

Surge voltage suppressor	DC		AC
	24	12	
S, Z	Approx. 1 V		Approx. 1 V
R, U	Approx. 47 V	Approx. 32 V	—

## Continuous Duty

### ⚠ Caution

If a valve is energized continuously for a long period of time, the rise in temperature due to heat-up of the coil assembly may cause a decline in solenoid valve performance, reduce service life, or have adverse effects on peripheral equipment. In particular, if 3 or more adjacent stations on the manifold are energized simultaneously for extended periods of time, take special care as the temperature rise will be greater. In such cases, if it is possible to select a valve with a power-saving circuit, be sure to do so.

## UL Approved Product

### ⚠ Caution

When conformity to UL is required, the product should be used with a UL1310 Class 2 power supply. The product is a UL approved product only if it has a  mark on the body.



# VF1000/3000/5000 Series Specific Product Precautions 5

Be sure to read before handling.

## One-touch Fittings

### ⚠ Caution

When fittings are used, they may interfere with one another depending on their types and sizes. Therefore, the dimensions of the fittings to be used should first be confirmed in their respective catalogs.

Fittings whose compliance with the VF series is already confirmed are stated below.

If the fitting within the applicable range is selected, there will not be any interference.

#### Applicable Fittings: KQ2H, KQ2S Series

Series	Model	Piping port	Port size	Applicable tubing O.D.						
				ø3.2	ø4	ø6	ø8	ø10	ø12	ø16
VF1000	VF1□20-□□1-M5	4(A), 2(B)	M5	██████████						
		5(EA), 3(EB)	M5	██████████						
	VF1□20-□□1-01	4(A), 2(B)	1/8	██████████						
		5(EA), 3(EB)	M5	██████████						
	VF1□3□-□□1-M5	4(A), 2(B)	M5	██████████						
		4(A), 2(B)	1/8	██████████						
	Type 30 manifold base	1(P), 5/3(R)	1/8	██████████						
	Type 31 manifold base	1(P)	1/8	██████████						
5(EA), 3(EB)		M5	██████████							

Series	Model	Piping port	Port size	Applicable tubing O.D.						
				ø3.2	ø4	ø6	ø8	ø10	ø12	ø16
VF3000	VF3□3□-□□1-01	4(A), 2(B)	1/8	██████████						
		1(P), 5(EA), 3(EB)	1/8	██████████						
	VF3□3□-□□1-02 <small>Note)</small>	4(A), 2(B)	1/4	██████████						
		1(P), 5(EA), 3(EB)	P: 1/4, EA, EB: 1/8	██████████						
	VF3□4□-□□1-02	4(A), 2(B)	1/4	██████████						
		1(P), 5(EA), 3(EB)	1/4	██████████						
	VF3□4□-□□1-03	4(A), 2(B)	3/8		██████████					
		1(P), 5(EA), 3(EB)	3/8		██████████					
	Type 30 manifold base	1(P), 5(R), 3(R)	1/4	██████████						
	Type 40 manifold base	4(A), 2(B)	1/4	██████████						
1(P), 5(R), 3(R)		1/4	██████████							

Note)VF3000 series of body ported and port size 1/4 specification is cannot use the packing seal type one-touch fitting: KQ2\*-\*\*P(1) series.

Series	Model	Piping port	Port size	Applicable tubing O.D.					
				ø3.2	ø4	ø6	ø8	ø10	ø12
VF5000	VF5□2□-□□1-02	4(A), 2(B)	1/4	██████████					
		1(P), 5(EA), 3(EB)	1/4	██████████					
	VF5□2□-□□1-03	4(A), 2(B)	3/8		██████████				
		1(P), 5(EA), 3(EB)	3/8		██████████				
	VF5□44-□□1-02	4(A), 2(B)	1/4	██████████					
		1(P), 5(EA), 3(EB)	1/4	██████████					
	VF5□44-□□1-03	4(A), 2(B)	3/8		██████████				
		1(P), 5(EA), 3(EB)	3/8		██████████				
	VF5□44-□□1-04	4(A), 2(B)	1/2			██████████			
		1(P), 5(EA), 3(EB)	1/2			██████████			
	Type 20 manifold base	1(P), 5(R), 3(R)	3/8		██████████				
	Type 21 manifold base	1(P), 5(R), 3(R)	1/2			██████████			
	Type 40 manifold base	4(A), 2(B)	1/4	██████████					
		1(P), 5(R), 3(R)	3/8		██████████				

## TROUBLE SHOOTING

Should any trouble be found during operation, trace the source of the trouble in the following order and take corrective action.

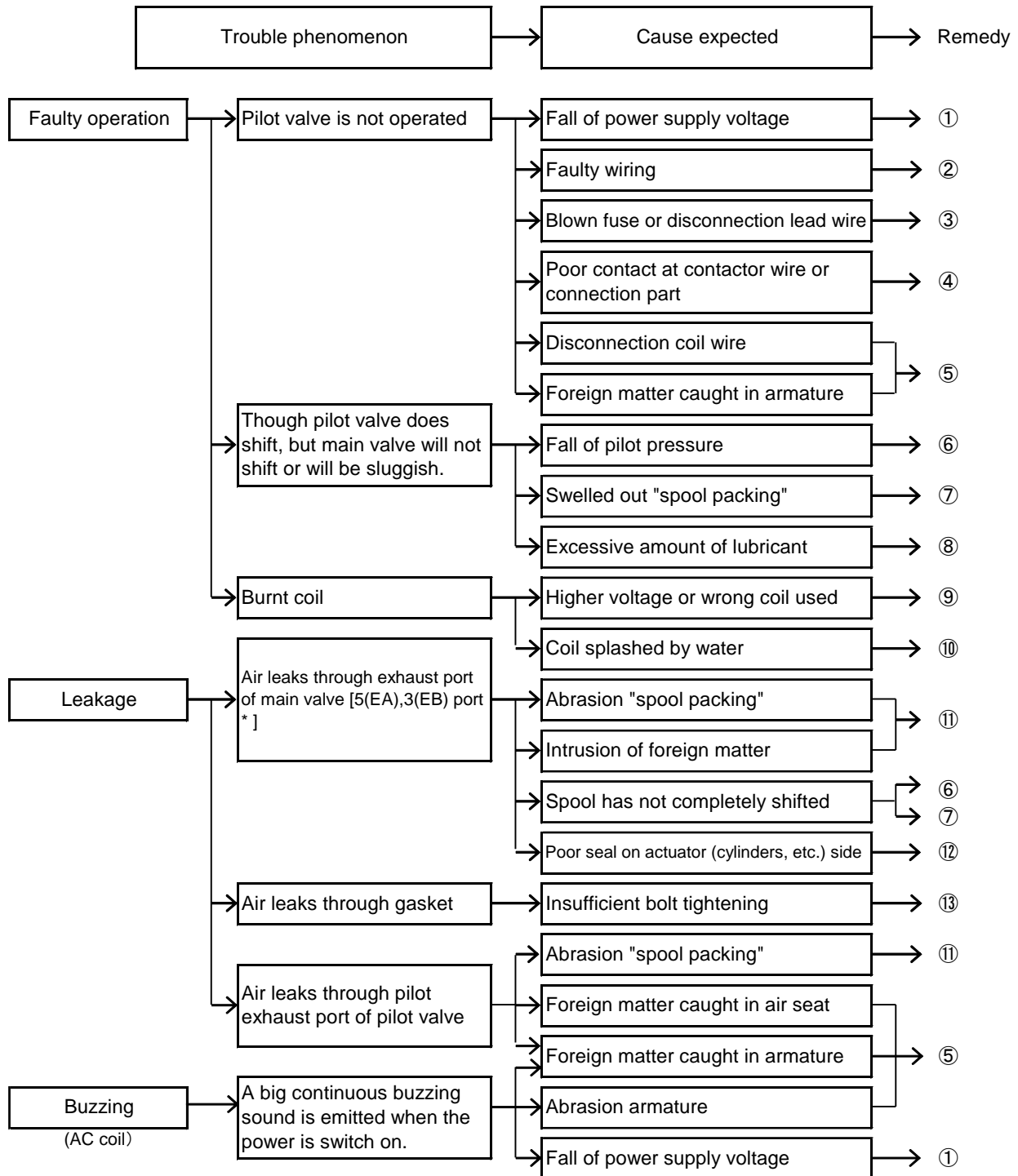

## Remedy

No.	Remedy
①	Regulate voltage, so that the voltage at the time of the operation becomes specifications range.
②	Re-wire positively.
③	Replace part.
④	Replace part or re-wire positively.
⑤	Replace valve. (Pilot valve)
⑥	Regulate pressure so that pilot pressure will fall within operating pressure range during operation.
⑦	·If wrong oil is used, completely air blow to remove oil, and replace valve. After valve is replaced, use turbine oil class 1 (ISO VG32). ·When a large quantity of drain is given and cannot carry out drain omission surely, install either an auto-drain or a dryer. The valve should be replaced.
⑧	Reduce the amount of oil so that the oil does not scatter from air exhaust port[5(EA), 3(EB) port, PE port].
⑨	Check voltage. Replace valve (pilot valve).
⑩	Replace valve (pilot valve). Protect the valve so that water does not splash the coil. When it is used in the environment where coming in direct contact with water, please choose IP65 specifications.
⑪	In case of intrusion of foreign matter, to remove foreign matter by air blow of piping and then replace valve.
⑫	Repair or replace actuators.
⑬	After stopping air and re-tighten the bolts.
⑭	Replace valve. (Pilot valve)

If no improvement is achieved in spite of the above countermeasure, inside of the valve may have some abnormality. In this case, stop using the valve immediately.

If any of followings are carried out, inside of the valve may have some failure. In this case, stop using the valve immediately.

1. Voltage out of rated voltage has been used.
2. Oil other than the specified one has been lubricated.
3. Lubrication has been stopped intermediately, or lubrication was suspended temporary.
4. Water splashed directly.
5. Strong impact was given.
6. Alien substance such as drain and particle got into. Drain or garbage invaded a valve.
7. Prohibited way of using the valve which is written at "Precautions" section in this operation manual was carried out excluding above-mentioned.

If you request us to investigate, please send the valve back to us in its original condition without disassembling it.



Revision history		
A	Safety Instructions	2011.2
B	Precautions for Solenoid Valve	2024.12

# SMC Corporation

Tel: + 81 3 5207 8249 Fax: +81 3 5298 5362

URL <https://www.smcworld.com>

---

Note: Specifications are subject to change without prior notice and any obligation on the part of the manufacturer.  
© SMC Corporation All Rights Reserved

No.VF1000-OMN0002-B