



Operation Manual

PRODUCT NAME

Solenoid Valve

MODEL/ Series

SY3000/5000/7000 Series
Plug-in Type

SMC Corporation

Contents

Safety Instructions	2,3
Design / Selection	4,5
Mounting	6
Piping	6
Wiring	6
Lubrication	7
Air Supply	7
Operating Environment	8
Maintenance	8
UL approved product	8
Specific Product Precautions	9 ~16
Construction and optional parts	17~19
Trouble shooting	20,21



Safety Instructions

These safety instructions are intended to prevent hazardous situations and/or equipment damage. These instructions indicate the level of potential hazard with the labels of “**Caution**,” “**Warning**” or “**Danger**.” They are all important notes for safety and must be followed in addition to International Standards (ISO/IEC)*¹⁾, and other safety regulations.

*1) ISO 4414: Pneumatic fluid power - General rules and safety requirements for systems and their components
ISO 4413: Hydraulic fluid power - General rules and safety requirements for systems and their components
IEC 60204-1: Safety of machinery - Electrical equipment of machines - Part 1: General requirements
ISO 10218-1: Robots and robotic devices - Safety requirements for industrial robots - Part 1: Robots
etc.

	Danger	Danger indicates a hazard with a high level of risk which, if not avoided, will result in death or serious injury.
	Warning	Warning indicates a hazard with a medium level of risk which, if not avoided, could result in death or serious injury.
	Caution	Caution indicates a hazard with a low level of risk which, if not avoided, could result in minor or moderate injury.

Warning

1. The compatibility of the product is the responsibility of the person who designs the equipment or decides its specifications.

Since the product specified here is used under various operating conditions, its compatibility with specific equipment must be decided by the person who designs the equipment or decides its specifications based on necessary analysis and test results. The expected performance and safety assurance of the equipment will be the responsibility of the person who has determined its compatibility with the product. This person should also continuously review all specifications of the product referring to its latest catalog information, with a view to giving due consideration to any possibility of equipment failure when configuring the equipment.

2. Only personnel with appropriate training should operate machinery and equipment.

The product specified here may become unsafe if handled incorrectly. The assembly, operation and maintenance of machines or equipment including our products must be performed by an operator who is appropriately trained and experienced.

3. Do not service or attempt to remove product and machinery/equipment until safety is confirmed.

1. The inspection and maintenance of machinery/equipment should only be performed after measures to prevent falling or runaway of the driven objects have been confirmed.
2. When the product is to be removed, confirm that the safety measures as mentioned above are implemented and the power from any appropriate source is cut, and read and understand the specific product precautions of all relevant products carefully.
3. Before machinery/equipment is restarted, take measures to prevent unexpected operation and malfunction.

4. SMC products cannot be used beyond their specifications. They are not developed, designed, and manufactured to be used under the following conditions or environments. Use under such conditions or environments is not allowed.

1. Conditions and environments outside of the given specifications, or use outdoors or in a place exposed to direct sunlight.
2. Use for nuclear power, railways, aviation, space equipment, ships, vehicles, military application, equipment affecting human life, body, and property, combustion equipment, entertainment equipment, emergency shut-off circuits, press clutches, brake circuits, safety equipment, etc., and use for applications that do not conform to standard specifications such as catalogs and operation manuals.
3. Use for interlock circuits, except for use with double interlock such as installing a mechanical protection function in case of failure. Please periodically inspect the product to confirm that the product is operating properly.



Safety Instructions

Caution

SMC develops, designs, and manufactures products to be used for automatic control equipment, and provides them for peaceful use in manufacturing industries.

Use in non-manufacturing industries is not allowed.

Products SMC manufactures and sells cannot be used for the purpose of transactions or certification specified in the Measurement Act of each country.

The new Measurement Act prohibits use of any unit other than SI units in Japan.

Limited warranty and Disclaimer/Compliance Requirements

The product used is subject to the following “Limited warranty and Disclaimer” and “Compliance Requirements”. Read and accept them before using the product.

Limited warranty and Disclaimer

1. The warranty period of the product is 1 year in service or 1.5 years after the product is delivered, whichever is first.*2)
Also, the product may have specified durability, running distance or replacement parts. Please consult your nearest sales branch.
2. For any failure or damage reported within the warranty period which is clearly our responsibility, a replacement product or necessary parts will be provided.
This limited warranty applies only to our product independently, and not to any other damage incurred due to the failure of the product.
3. Prior to using SMC products, please read and understand the warranty terms and disclaimers noted in the specified catalog for the particular products.

***2) Vacuum pads are excluded from this 1 year warranty.**

A vacuum pad is a consumable part, so it is warranted for a year after it is delivered.

Also, even within the warranty period, the wear of a product due to the use of the vacuum pad or failure due to the deterioration of rubber material are not covered by the limited warranty

Compliance Requirements

1. The use of SMC products with production equipment for the manufacture of weapons of mass destruction (WMD) or any other weapon is strictly prohibited.
2. The exports of SMC products or technology from one country to another are governed by the relevant security laws and regulations of the countries involved in the transaction. Prior to the shipment of a SMC product to another country, assure that all local rules governing that export are known and followed.



Precautions for 5 Port Solenoid Valve 1

Be sure to read before handling.

Design / Selection

Warning

1. **Confirm the specifications**

Products represented in this instruction manual are designed only for use in compressed air systems (including vacuum).

Do not operate at pressures or temperatures, etc., beyond the range of specifications, as this can cause damage or malfunction. (Refer to the specifications.)

We do not guarantee against any damage if the product is used outside of the specification range.

2. **Actuator drive**

When an actuator, such as a cylinder, is to be driven using a valve, take appropriate measures (cover installation or approach prohibition) to prevent potential danger caused by actuator operation.

3. **Intermediate stops**

For 3-position closed center or double check valve type, it is difficult to make a piston stop at the required position accurately due to the compressibility of air.

Furthermore, since valves and cylinders are not guaranteed for zero air leakage, it may not be possible to hold a stopped position for an extended period of time.

4. **Effect of back pressure when using a manifold.**

Use caution when valves are used on a manifold, because an actuator may malfunction due to back-pressure. For 3-position exhaust center valve or single acting cylinder, take appropriate measures to prevent malfunction by using it with an individual EXH spacer assembly or a back pressure check valve.

5. **Holding pressure (including vacuum).**

Since the valve are subject to air leakage, they cannot be used for applications such as holding pressure (including vacuum) in a pressure vessel.

6. **Not suitable for use as an emergency shut-off valve, etc.**

The valves listed in this instruction manual are not designed for safety applications such as an emergency shutoff valve. If the valves are used for the mentioned applications, additional safety measures should be adopted.

7. **Release of residual pressure**

For maintenance purposes install a system for releasing residual pressure. Especially in the case of 3-position closed center valve or double check valve type, ensure that the residual pressure between the valve and the cylinder is released.

8. **Operation in a vacuum condition**

When a valve is used for switching a vacuum, take measures to install a suction filter or similar to prevent external dust or other foreign matter from entering inside the valve. In addition, at the time of vacuum adsorption, be sure to supply a constant supply of vacuum. Failure to do so may result in foreign matter sticking to the adsorption pad or air leakage, causing the workpiece to drop.

9. **Regarding a vacuum switch valve**

For maintenance purposes install a system for releasing residual pressure.

10. **Double solenoid type**

When using the double solenoid type for the first time, actuators may travel in an unexpected direction depending on the switching position of the valve. Implement measures to prevent any danger from occurring when operating the actuator.

11. **Ventilation**

Provide ventilation when using a valve in a confined area, such as in a closed control panel. For example, install a ventilation opening, etc. in order to prevent pressure from increasing inside of the confined area and to release the heat generated by the valve.

12. **Extended periods of continuous energization.**

- If a valve will be continuously energized for an extended period of time, the temperature of the valve will increase due to the heat generated by the coil. This will likely adversely affect the performance of the solenoid valve and any nearby peripheral equipment. Therefore, when it is continuously energized or the energized period per day is longer than the de-energized period use either: DC specification, power-saving type. Also, please contact SMC because depending on the application, there may be additional valves not mentioned above that may be used. In addition, it is possible to shorten the energized time by making a valve with an N.O. (normally open) specification.

- For applications such as mounting a valve on a control panel, incorporate measure to limit the heat radiation so that it is within the operation temperature range.

13. **Do not disassemble the product or make any modifications, including additional machining.**

It may cause human injury and/or an accident.



SY Series

Precautions for 5 Port Solenoid Valve 2

Be sure to read before handling.

Design / Selection

! Caution

1. Momentary energization

If a double solenoid valve is operated with momentary energization, it should be energized for at least 0.1 second. However, depending on the piping conditions, cylinder may malfunction even when the double solenoid valve is energized for 0.1 second or longer. In this case, energize the double solenoid valve until the cylinder is exhausted completely.

2. Leakage voltage

Take note that the leakage voltage will increase when a resistor is used in parallel with switching element or a C-R circuit (surge voltage suppressor) is used for protecting a switching device because of the passing leakage voltage through the C-R circuit. The suppressor residual leakage voltage should be 3% or less of the rated voltage.

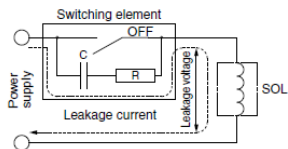

3. Surge voltage suppressor

- 1) A surge voltage suppressor built into the valve is intended to protect the output contacts so that the surge generated inside valve does not adversely affect the output contacts. Therefore, if an overvoltage or overcurrent is received from an external peripheral device, the surge voltage protection element inside the valve is overloaded, causing the element to break. In the worst case, the electric circuit enters the short-circuit status by the breakage. If the energizing continues in this status, a large current flows. This may cause secondary damage to the output circuit, external peripheral device, or valve, and may also cause fire accident. So, take appropriate protective measures, such as installation of an overcurrent protection circuit in the power supply or drive circuit to maintain the sufficient safety.
- 2) If a surge protection circuit contains nonstandard diodes, such as Zener diodes or varistor, a residual voltage that is in proportion to the protective circuit and the rated voltage will remain. Therefore, take into consideration the surge voltage protection of the controller. In the case of diodes, the residual voltage is approximately 1 V.

4. Operation in a low temperature condition

It is possible to operate a valve in extreme temperature, as low as -10 °C. Take appropriate measures to avoid freezing of drainage, moisture etc. in low temperature.

5. Operation for air blowing

When using a solenoid valve for air blowing, use an external pilot type. Use caution because the pressure drop caused by the air blowing can have an affect on the internal pilot type valve when the internal pilot type valves and external pilot type valves are used on the same manifold. Additionally, when compressed air within the pressure range of the established specifications is supplied to the external pilot type valve's port, and a double solenoid valve is used for air blowing, the solenoids should normally be energized when air is being blown.

6. Mounting orientation

Rubber seal: Mounting orientation is free.
Metal seal: Mounting orientation of a single solenoid is universal.
When installing a double solenoid or a 3-position configuration, mount the valve so that spool valve is horizontal.

Mounting

! Warning

1. Operation manual

Install the products and operate them only after reading the operation manual carefully and understanding its contents. Also, keep the manual where it can be referred to as necessary.

2. Ensure sufficient space for maintenance activities.

When installing the products, allow access for maintenance.

3. Tighten threads with the proper tightening torque.

When installing the products, follow the listed torque specifications.

4. If air leakage increases or equipment does not operated properly, stop operation.

Check mounting conditions when air and power supplies are connected. Initial function and leakage tests should be performed after installation.

5. Painting and coating

Warnings or specifications printed on or affixed to the product should not be erased, removed, or covered up.

Also, applying paint to resinous parts may have an adverse effect due to the solvent in the paint.



SY Series

Precautions for 5 Port Solenoid Valve 3

Be sure to read before handling.

Piping

⚠ Caution

- 1. Refer to the Fittings and Tubing precautions for handling one-touch fittings.**
- 2. Preparation before piping**
Before piping is connected, it should be thoroughly blown out with air (flushing) or washed to remove chips, cutting oil and other debris from inside the pipe.
- 3. Wrapping of pipe tape**
When screwing piping or fittings into ports, ensure that chips from the pipe threads or sealing material do not enter the piping. Also, if pipe tape is used, leave 1 thread ridges exposed at the end of the threads.

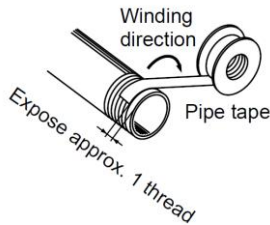

- 4. Closed center and double check valve types**
For the closed center or double check valve types, check the piping to prevent air leakage from the piping between the valve and the cylinder.
- 5. Connection of fittings**
When screwing fittings into valves, tighten as follows.
 - (1) Follow the procedures below when installing an SMC fitting, etc.
 - **M5 types**
After tightening the fitting by hand, use a wrench to tighten the fitting an additional approximately 1/6 to 1/4 turn. As a reference value, tightening torque is 1 to 1.5 N·m.
(Note) If tightened excessively, the thread of the product may break or the gasket may deform. If tightened insufficiently, the thread of the product may become loose. In either case, air leakage can occur.
 - **Follow the procedure of the manufacture when fittings other than SMC is used.**

- (2) **Rc type**
Tighten with the proper torque shown below.

Tightening Torque for Piping Applicable

Connection thread	Proper tightening torque (N·m)
Rc1/8	3 to 5
Rc1/4	8 to 12
Rc3/8	14 to 16

- 6. Piping to products**
When piping to a product, avoid mistakes regarding the supply port, etc.

Wiring

⚠ Caution

- 1. Polarity**
When connecting power to a solenoid valve with a DC specification and equipped with a light or surge voltage suppressor, check for polarity. If there is polarity, take note of the following.

No diode to protect polarity.

If a mistake is made regarding the polarity, damage may occur to the diode in the valve, the switching element in a control device or power supply equipment, etc.

With diode to protect polarity.

If polarity connection is wrong, the valve does not operate.

- 2. Applied voltage**
When electric power is connected to a solenoid valve, be careful to apply the proper voltage. Improper voltage may cause malfunction or coil damage.
- 3. Check the connections.**
Check if the connections are correct after completing all wiring.



SY Series

Precautions for 5 Port Solenoid Valve 4

Be sure to read before handling.

Lubrication

Warning

Lubrication

[Rubber seal]

- 1) The valve has been lubricated for life by the factory and does not require any further.
- 2) If a lubricant is used in the system, use class 1 (no additives) and class 2 (with additives) ISO VG32 turbine oil. For details about lubricant manufacturers' brands, refer to the SMC website. Once lubricant is utilized within the system, since the original lubricant applied within the product during manufacturing will be washed away, please continue to supply lubrication to the system. Without continued lubrication, malfunctions could occur. If turbine oil is used, refer to the Material Safety Data Sheet (SDS) of the oil.

[Metal seal]

- 1) These valves can be used without lubrication.
- 2) If a lubricant is used in the system, use class 1 (no additives) and class 2 (with additives) ISO VG32 turbine oil. For details about lubricant manufacturers' brands, refer to the SMC website.

Lubrication amount

If the lubrication amount is excessive, the oil may accumulate inside the pilot valve, causing malfunction or response delay. So, do not apply a large amount of oil. When a large amount of oil needs to be applied, use an external pilot type to put the supply air on the pilot valve side in the non-lube state. This prevents the accumulation of oil inside the pilot valve.

Air Supply

Warning

1. **Type of fluids**
Be sure to use compressed air for the fluid.
2. **When there is a large amount of drainage.**
Compressed air containing a large amount of drainage can cause malfunction of pneumatic equipment. An air dryer or water separator should be installed upstream from filters.
3. **Drain flushing**
If condensation in the drain bowl is not emptied on a regular basis, the bowl will overflow and allow the condensation to enter the compressed air lines. It causes malfunction of pneumatic equipment. If the drain bowl is difficult to check and remove, installation of a drain bowl with an auto drain option is recommended. For compressed air quality, refer to SMC's Best Pneumatics catalog.
4. **Use clean air**
Do not use compressed air that contains chemicals, synthetic oils including organic solvents, salt or corrosive gasses, etc., as it can cause damage or malfunction.

Caution

1. **When low dew point air is used as the fluid, degradation of the lubrication properties inside the equipment may occur, resulting in reduced reliability (or reduced service life) of the equipment. Consider using products compatible with low dew points such as those from the 25A- series.**
2. **Install an air filter.**
Install an air filter upstream near the valve. Select an air filter with a filtration size of 5 µm or smaller.
3. **Take measures to ensure air quality, such as by installing an aftercooler, air dryer, or water separator.**
Compressed air that contains a large amount of drainage can cause malfunction of pneumatic equipment such as valves. Therefore, take appropriate measures to ensure air quality, such as by providing an aftercooler, air dryer, or water separator.
4. **If excessive carbon powder is seen, install a mist separator on the upstream side of the valve.**
If excessive carbon dust is generated by the compressor, it may adhere to the inside of a valve and cause it to malfunction. For compressed air quality, refer to SMC Best Pneumatics No.6 catalog.



SY Series

Precautions for 5 Port Solenoid Valve 5

Be sure to read before handling.

Operating Environment

Warning

1. Do not use in an atmosphere having corrosive gases, chemicals, sea water, water, water steam, or where there is direct contact with any of these.
2. Products with IP65 and IP67 enclosures (based on IEC60529) are protected against dust and water, however, these products cannot be used in water.
3. Products compliant to IP65 and IP67 satisfy the specifications through mounting. Be sure to read the Precautions for each product.
4. Do not use in an environment where flammable gas or explosive gas exists. Usage may cause a fire or explosion. The products do not have an explosion proof construction.
5. Do not use in a place subject to heavy vibration and/or shock.
6. The valve should not be exposed to prolonged sunlight. Use a protective cover.
7. Remove any sources of excessive heat.
8. If it is used in an environment where there is possible contact with oil, weld spatter, etc., exercise preventive measures.
9. When the valve is mounted in a control panel or its energized for a long time, make sure ambient temperatures is within the specification of the valve.

Maintenance

Warning

1. **Perform maintenance inspection according to the procedures indicated in the operation manual.**
If handled improperly, malfunction and damage of machinery or equipment may occur.
2. **Removal of equipment and supply/exhaust of compressed air**
When components are removed, first confirm that measures are in place to prevent workpieces from dropping, run-away equipment, etc. Then, cut off the supply pressure and electric power, and exhaust all compressed air from the system using the residual pressure release function.
For 3-position closed center type, exhaust the residual pressure between the valve and the cylinder. When the equipment is operated after remounting or replacement, first confirm that measures are in place to prevent lurching of actuators, etc. Then, confirm that the equipment is operating normally.
3. **Low frequency operation**
Valves should be operated at least once every 30 days to prevent malfunction. (Use caution regarding the air supply.)
4. **Manual override operation**
When the manual override is operated, connected equipment will be actuated. Operate after safety is confirmed.

Caution

1. **Drain flushing**
Remove drainage from the air filters regularly.
2. **Lubrication**
In the case of rubber seals, once lubrication has been started, it must be continued.
Use class 1 (no additive), and class 2 (with additives) ISO VG32 turbine oil. For details about lubricant manufacturers' brands, refer to the SMC website. If other lubricant oil is used, it may cause a malfunction.

UL approved product

Caution

When conformity to UL is required, the SI unit should be used with a UL 1310 Class 2 power supply. The SI unit is a UL approved product only if they have a  mark on the body.



SY series

Specific Product Precautions 1

Be sure to read this before handling

Operating Environment

Warning

- Do not use in an atmosphere having corrosive gases, chemicals, sea water, water, water steam, or where there is direct contact with any of these.
- Products compliant with IP67 enclosures (based on IEC60529) are protected against dust and water, however, these products cannot be used in water. If using in an environment that is exposed to water and dust splashes, take measures such as using a protective cover.
- When using built-in silencer type manifold with an IP67 enclosure, keep the exhaust port of the silencer from coming in direct contact with water or other liquids.
- The metal seal valve is provided with a hole to discharge the pilot EXH. When using in atmospheres containing water and dust, mount it horizontally.

Valve Mounting

Caution

Mount it so that there is no slippage or deformation in gaskets, and tighten with the tightening torque as shown below.

Series	Thread size	Tightening torque
SY3000	M2	0.16 N·m
SY5000/7000	M3	0.8 N·m

Manual Override

Warning

Regardless of an electric signal for the valve, the manual override is used for switching the main valve. Connected actuator is started by manual operation. Use the manual override after confirming that there is no danger.

Non-locking push type

Push down on the manual override button until it stops.

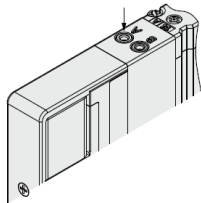

Push-turn locking slotted type [Type D]

Push down on the manual override with a small flat head screwdriver until it stops. Turn it clockwise by 90° to lock it. Turn it counterclockwise to release it. If it is not turned, it can be operated the same way as the non-locking type.

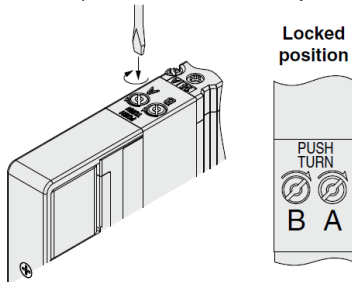

Push-turn locking lever type [Type E]

Push down on the manual override by finger until it stops, and then turn it 60° clockwise. The manual override is then locked.

To release it, turn it counterclockwise. If it is not turned, it can be operated the same way as the non-locking type.

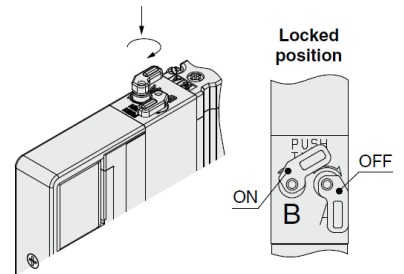

Carefully check the manual override projection amount.
Max. (at OFF): 3.7 mm

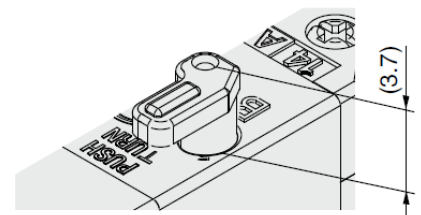

Caution

Do not apply excessive torque when turning the manual override. [0.1 N·m] When locking the manual override, be sure to push it down before turning. Turning without first pushing it down can cause damage to the manual override and other trouble such as air leakage, etc.

Slide locking type (Manual)

It is locked by sliding the manual override all the way in the direction indicated by the arrow (ON side) with a small flat head screwdriver or with your fingers. Slide it in the direction indicated by the arrow (OFF side) to release it.

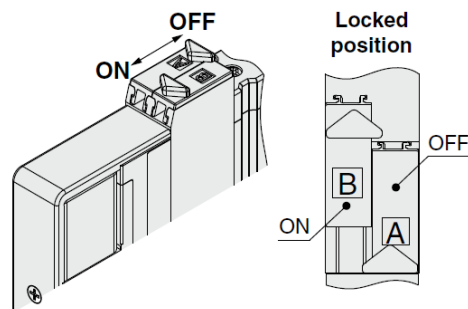



SY series Specific Product Precautions 2

Be sure to read this before handling

Back Pressure Check Valve

⚠ Caution

There are two types of back pressure check valves; the one which is built into a valve (with rubber seal type only) and the one which is built in on the manifold side with connector connection. Both of them have a check valve built-in to prevent back pressure. For this reason, use caution that the valves with external pilot specification cannot be pressurized from exhaust port [3/5(E)]. As compared with the types which do not integrate the back pressure check valve, C value of the flow rate characteristics goes down. Please contact SMC for details.

Exhaust Throttle

⚠ Caution

The SY series pilot valve and main valve share a common exhaust inside the valve. Therefore, do not block the exhaust port when arranging the piping.

Used as a 3-Port Valve

⚠ Caution

- In case of using a 5-port valve as a 3-port valve**
The SY3000/5000/7000 series can be used as normally closed (N.C.) or normally open (N.O.) 3-port port valves by closing one of the cylinder ports 4(A) or 2(B) with a plug. However, they should be used with the exhaust ports kept open. They are convenient at times when a double solenoid type 3-port valve is required.

Plug position		B port	A port
Type of actuation		N.C.	N.O.
Number of solenoids	Single	(A)4 2(B) (EA)5 1 3(E)B (P)	(A)4 2(B) (EA)5 1 3(E)B (P)
	Double	(A)4 2(B) (EA)5 1 3(E)B (P)	(A)4 2(B) (EA)5 1 3(E)B (P)

Valve and Manifold Combination

The SY series plug-in valve has the common configuration of the valve mounting surface between base mounted type (SY3/5/7□0□) and top ported type (SY3/5/7□3□), therefore, it can be mounted to all manifolds of the side ported type (type 50 and type 10), the bottom 0ported type (type 51 and type 11) and the top ported type (type 52 and type 12).

For example, air output can be obtained from both sides of the A and B ports of the manifold and the valve by mounting a top ported valve to a side ported or bottom ported manifold, and a pressure switch can be connected to the output port on one side.

However, when selecting valves and manifolds, note that when a base mounted valve is mounted to a top ported manifold, there will be no output from the A and B port.

Light/Surge Voltage Suppressor

⚠ Caution

■ Polar type

Positive common

Single solenoid

Light/surge voltage suppressor (□Z)

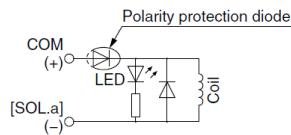

Surge voltage suppressor (□S)

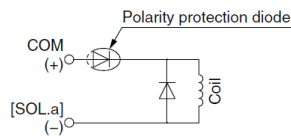

Negative common

Single solenoid

Light/surge voltage suppressor (□NZ)

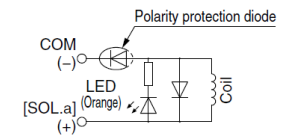

Surge voltage suppressor (□NS)

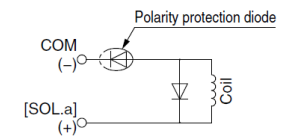

Positive common

Double solenoid, 3-position, 4-position

Light/surge voltage suppressor (□Z)

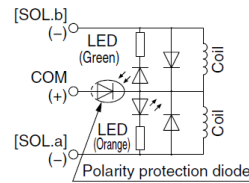

Surge voltage suppressor (□S)

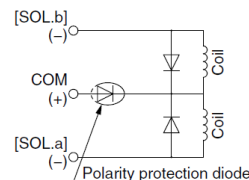

Negative common

Double solenoid, 3-position, 4-position

Light/surge voltage suppressor (□NZ)

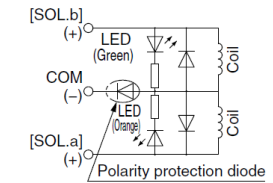

Surge voltage suppressor (□NS)

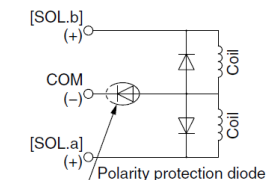

■ Non-polar type

With surge voltage suppressor (□R)

Single solenoid

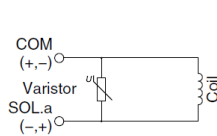

Double solenoid

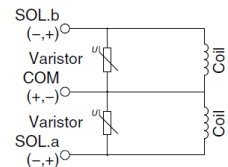

With light/surge voltage suppressor (□U)

Single solenoid

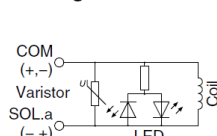

Double solenoid

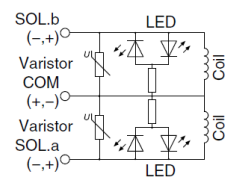



SY series Specific Product Precautions 3

Be sure to read this before handling

Light/Surge Voltage Suppressor

⚠ Caution

■ With power saving circuit

Power consumption is decreased by approx. 1/3 by reducing the wattage required to hold the valve in an energized state. (Effective energizing time is over 67 ms at 24 VDC.)

*: Be careful of the energizing time, as quick response and high pressure types will become operational when the energizing time is over 40 ms.

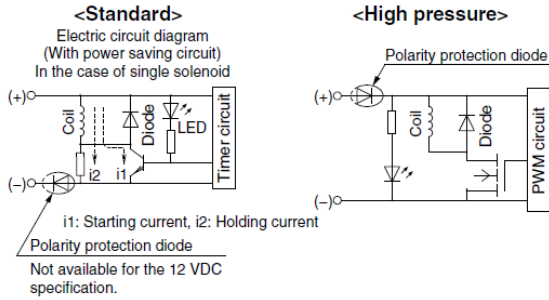

The above circuit reduces the power consumption for holding in order to save energy. Refer to the electrical power waveform as shown below.

<Electrical power waveform with power saving circuit>

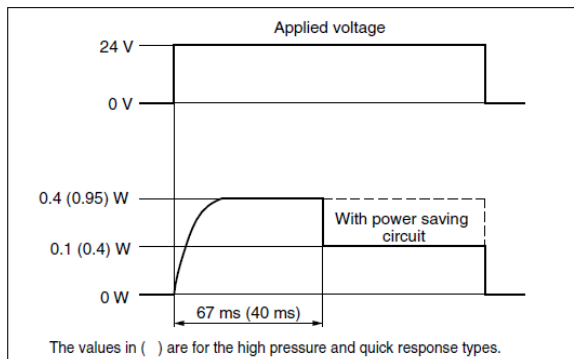

- The 12 VDC specification with power saving circuit (standard specification) does not have the polarity protection diode. Do not make a mistake with the polarity.
- Since the voltage will drop by approx. 0.5 V due to the transistor, pay attention to the allowable voltage fluctuation. (For details, refer to the solenoid specifications of each type of valve.)

Residual voltage of the surge voltage suppressor

*: If a varistor or diode surge voltage suppressor is used, there is some residual voltage to the protection element and rated voltage. Therefore, refer to the below table and pay attention to the surge voltage protection on the controller side. Also, since the response time does change, refer to the valve specifications on page 137.

Residual Voltage

Surge voltage suppressor	DC	
	24 V	12 V
S, Z	Approx. 1 V	
R, U	Approx. 47 V	Approx. 32 V

Continuous Duty

⚠ Caution

If a valve is energized continuously for a long period of time, the rise in temperature due to heat-up of the coil assembly may cause a decline in solenoid valve performance, reduce service life, or have adverse effects on peripheral equipment. If the valve is energized continuously for a long period of time, be sure to use a valve with power saving circuit. In particular, if three or more adjacent stations on the manifold are energized simultaneously for extended periods of time or if the valves on A side and B side are energized simultaneously for a long period of time, take special care as the temperature rise will be greater.



SY series

Specific Product Precautions 4

Be sure to read this before handling

Countermeasure for Surge Voltage Intrusion

■ Sneak-in of surge voltage

With non-polar type valves, at times of sudden interruption of the loading power supply, such as emergency shutdown, surge voltage intrusion may be generated from loading equipment with a large capacity (power consumption), and the valve in a de-energized state may switch over (see Figure 1). When installing a breaker circuit for the loading power supply, consider using a valve with polarity (with polarity protection diode), or install a surge absorption diode between the loading equipment COM line and the output equipment COM line (see Figure 2).

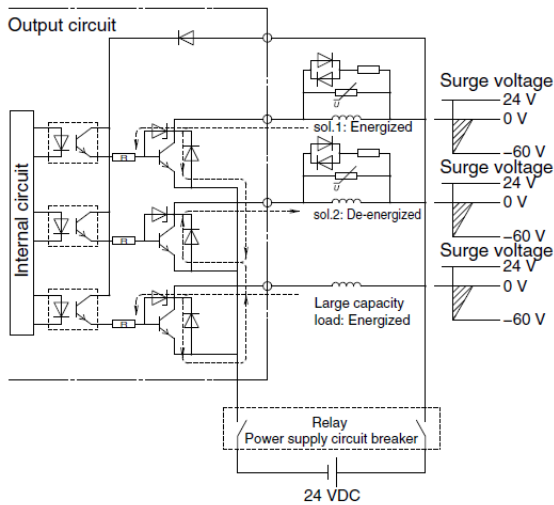

Figure 1. Surge intrusion circuit example (NPN outlet example) (24 VDC)

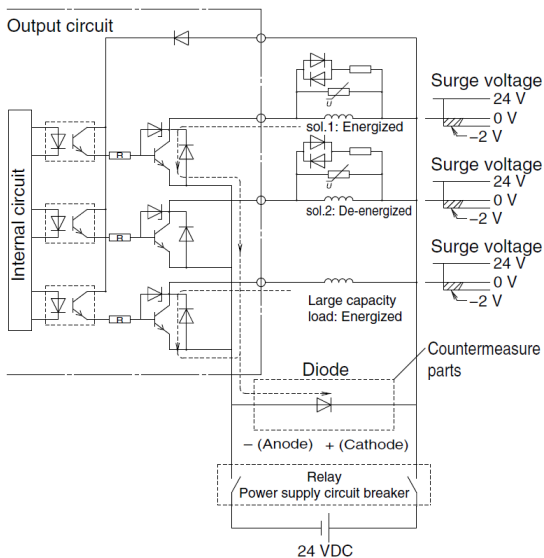
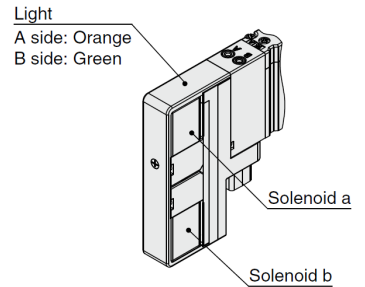

Figure 2. Surge intrusion circuit example (NPN outlet example) (24 VDC)

Light Indication

When equipped with indicator light and surge voltage suppressor, the light window turns orange when solenoid a is energized, and it turns green when solenoid b is energized.



Type 5 (Metal Base) Changing Connector Entry Direction

⚠ Caution

Connector direction for electrical entry of D-sub connector, flat ribbon cable and PC wiring can be changed. If the directional change is required, push the lever on both sides to remove the connector and change the connector direction for electrical entry as shown in the figure. Since lead wire assemblies are attached to the connector, excessive pulling or twisting can cause broken wires or other trouble. Also, take precautions so that lead wires are not caught and pinched when installing the connector.

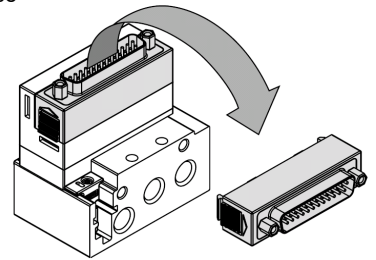

Type 1 (Connector Connecting Base) Changing Connector Entry Direction

⚠ Caution

Connector direction for electrical entry of D-sub connector, flat ribbon cable and PC wiring can be changed. If the directional change is required, slide the lever on the side of the connector block to the FREE position, and then change the direction as shown in the figure. Also, before connecting the connector, be sure to return the lever to the LOCK position. (If the lever is difficult to slide, move the connector a little bit to make it easier to slide the lever.) If an excessive force is applied on the connector in the LOCK position, the connector block may be damaged. Also, using in such a way that the connector floats in the FREE position, it may cause the lead wire, etc. to break. Thus, refrain from using in these ways.

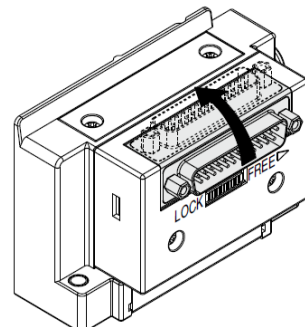



SY series

Specific Product Precautions 5

Be sure to read this before handling

Substrate Assemblies inside Manifolds

⚠ Caution

Substrate assemblies inside of manifolds cannot be taken apart. Attempting to do so may damage parts.

Fixation of DIN Rail Mounting Type Manifold

⚠ Caution

1. When the manifold is fixed with bolts on a mounting surface, etc., it can be operated just by fixing on both ends of the DIN rail if the bottom surface of the DIN rail is entirely in contact with the mounting surface when mounted horizontally. However, if it is used with other mounting or with side or reverse mounting, fix the DIN rail with bolts at regular intervals. As a guide, insert bolts in 2 positions for 2-5 stations, 3 positions for 6-10 stations, 4 positions for 11-15 stations, 5 positions for 16-20 stations and 6 positions for 21-24 stations. Take the same measures for horizontal mounting if the mounting surface vibrates.
2. When using the manifold with DIN rail in an environment where any vibration or impact is applied to it, the DIN rail itself may be broken. In particular, if the installation surface vibrates when mounting the manifold on the wall or if a load is directly applied to the manifold, the DIN rail may be broken, causing the manifold to drop. When any vibration, impact, or load is applied to the manifold, be sure to use the direct mounting manifold.

Port Block Assembly and How to Change Piping Types between Top and Side

⚠ Caution

For top ported type, the port size of A and B ports can be changed by switching the port block assemblies which are mounted on the body. The piping method can also be changed by switching the top ported type port block assembly with the side ported type cover assembly. Also, it may cause air leakage if the mounting screws are not tightened securely enough when they are switched. Take care to tighten to the correct tightening torque.

When switching them while valves are mounted on a manifold, remove the clip with a flat head screwdriver before switching the plug Ass'y and the One-touch fittings. It may cause air leakage if the mounting screws are not tightened or the clip is not inserted securely enough when they are switched. Take care to tighten to the correct tightening torque.

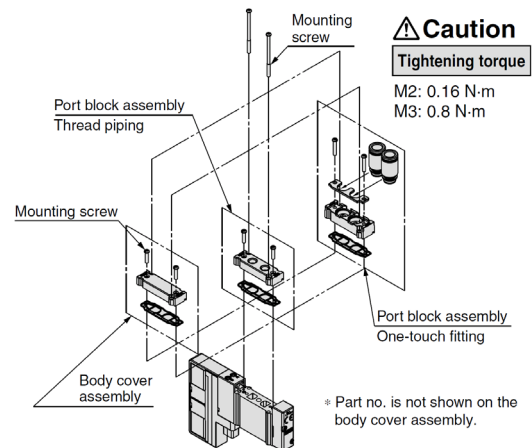

■How to change while mounted on a manifold

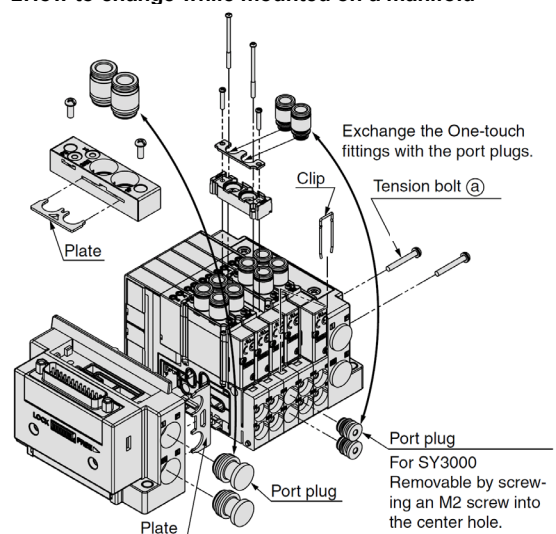



SY series Specific Product Precautions 6

Be sure to read this before handling

Changing One-touch Fittings

⚠ Caution

By replacing One-touch fittings of valve or manifold base, it is possible to change the connection diameter of the 4(A), 2(B), 1(P), 3/5(E) ports.

When replacing the One-touch fittings, remove the clip or the plate and the plate mounting screws with a screwdriver before pulling the One-touch fittings off. Mount the One-touch fittings by following the removal procedure in reverse. It may cause air leakage if the mounting screws are not tightened or the clip and the clip plate are not inserted securely enough when they are switched. Take care to tighten to the correct tightening torque.

■ Valve

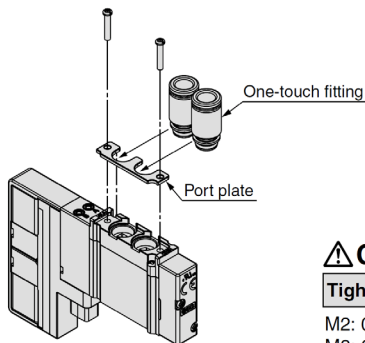

⚠ Caution

Tightening torque

M2: 0.16 N·m
M3: 0.8 N·m

■ Plug-in metal base

● Side ported

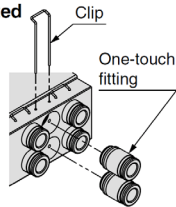

● Bottom ported

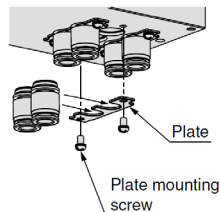

■ Plug-in connector connecting base

● Side ported

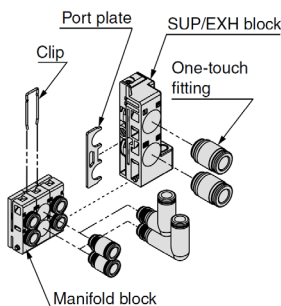

● Bottom ported

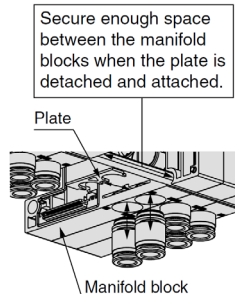

Secure enough space between the manifold blocks when the plate is detached and attached.

Changing One-touch Fittings

⚠ Caution

● Bottom ported (Type 11)

Secure enough space between the manifold blocks when the plate is detached and attached.

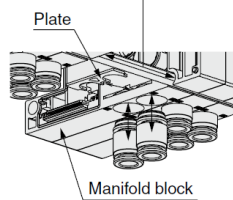

Plate part no. (10 pcs. included)

Series	Part no.
SY5000*1	SY50M-10-4A
SY3000/5000 Mixed mounting type	SY50M-10-5A
SY7000	SY70M-10-4A

*1: A and B ports (ø8 and ø5/16") of the SY3000/5000 mixed mounting type are those for the SY5000.

Other Tube Brands

⚠ Caution

- When using other than SMC brand tube, confirm that the following specifications are satisfied with respect to the tube outside diameter tolerance.

1) Nylon tube	within ±0.1 mm
2) Soft nylon tube	within ±0.1 mm
3) Polyurethane tube	within +0.15 mm -0.2 mm

Do not use tube which do not meet these outside diameter tolerances. It may not be possible to connect them, or they may cause other trouble, such as air leakage or the tube pulling out after connection.

One-touch Fittings

⚠ Caution

■ Tube attachment/detachment for One-touch fittings

1) Tube attachment

- Take a tube having no flaws on its periphery and cut it off at a right angle. When cutting the tube, use tube cutters TK-1, 2 or 3. Do not use pinchers, nippers or scissors, etc. If cutting is done with tools other than tube cutters, the tube may be cut diagonally or become flattened, etc., making a secure installation impossible. Allow some extra length in the tube.
- Grasp the tube and push it in slowly, inserting it securely all the way into the fitting.
- After inserting the tube, pull on it lightly to confirm that it will not come out. If it is not installed securely all the way into the fitting, this can cause problems such as air leakage or the tube pulling out.



SY series

Specific Product Precautions 7

Be sure to read this before handling

2) Tube detachment

1. Push in the release button sufficiently, pushing its collar equally around the circumference.
2. Pull out the tube while holding down the release button so that it does not come out. If the release button is not pressed down sufficiently, there will be increased bite on the tube and it will become more difficult to pull it out.
3. When the removed tube is to be used again, cut off the portion which has been chewed before reusing it. If the chewed portion of the tube is used as is, this can cause trouble such as air leakage or difficulty in removing the tube.



SY series Specific Product Precautions 8

Be sure to read this before handling

One-touch Fittings

⚠ Caution

When fittings are used, they may interfere with one another depending on their types and sizes. Therefore, the dimensions of the fittings to be used should first be confirmed in their respective catalogs.

Fittings whose compliance with the SY series is already confirmed are stated below. If the fitting within the applicable range is selected, there will not be any interference.

Applicable Fittings: Series KQ2H, KQ2S

Series KJH, KJS

Series	Model	Piping port	Port size	Fittings	Applicable tube O.D.							
					ø2	ø3.2	ø4	ø6	ø8	ø10	ø12	
SY3000	SY3□30-□□-M5	4A, 2B	M5	KQ2H	████████████████████							
				KQ2S		████████████████████						
	SS5Y3-50/51/52 (R) Manifold base	1P, 5EA, 3EB	1/8	KQ2H		████████████████████						
				KQ2S			████████████████████					
		X, PE	M5	KQ2H	████████████████████							
				KQ2S		████████████████████						
		4A, 2B	1/8	KQ2H		████████████████████						
				KQ2S			████████████████████					
	M5	KQ2H	████████████████████									
		KQ2S		████████████████████								

Series	Model	Piping port	Port size	Fittings	Applicable tube O.D.							
					ø2	ø3.2	ø4	ø6	ø8	ø10	ø12	
SY5000	SY5□30-□□-01	4A, 2B	1/8	KQ2H		████████████████████						
				KQ2S			████████████████████					
	SS5Y5-50/51/52 (R) Manifold base	1P, 5EA, 3EB	1/4	KQ2H		████████████████████						
				KQ2S			████████████████████					
		X, PE	M5	KQ2H	████████████████████							
				KQ2S		████████████████████						
		4A, 2B	1/4	KQ2H		████████████████████						
				KQ2S			████████████████████					
	1/8	KQ2H		████████████████████								
		KQ2S			████████████████████							

Series	Model	Piping port	Port size	Fittings	Applicable tube O.D.							
					ø2	ø3.2	ø4	ø6	ø8	ø10	ø12	
SY7000	SY7□30-□□-02	4A, 2B	1/4	KQ2H		████████████████████						
				KQ2S			████████████████████					
	SS5Y7-50/51/52 (R) Manifold base	1P, 5EA, 3EB	3/8	KQ2H			████████████████████					
				KQ2S				████████████████████				
		X, PE	M5	KQ2H	████████████████████							
				KQ2S		████████████████████						
	4A, 2B	1/4	KQ2H		████████████████████							
			KQ2S			████████████████████						

Valve Construction

Rubber Seal

2-position single

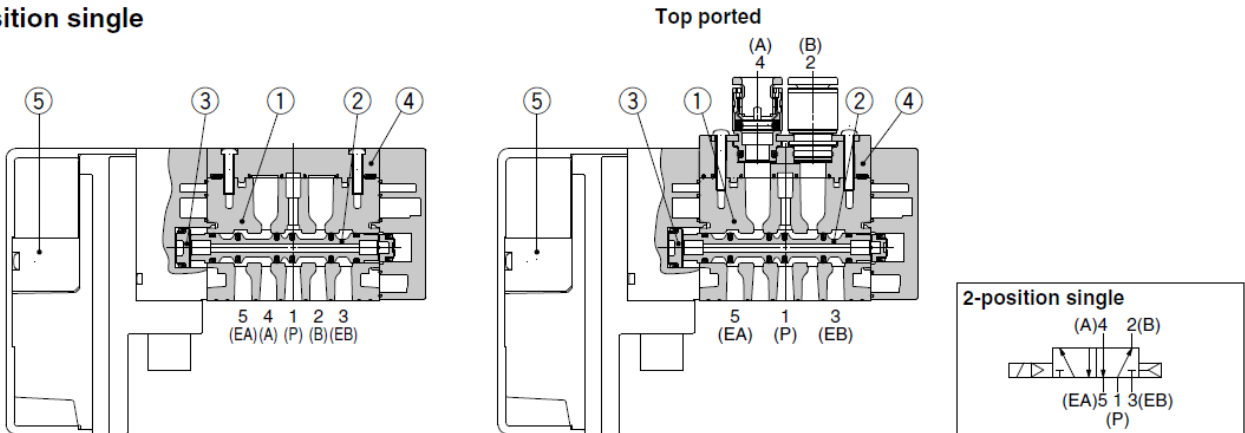

2-position double

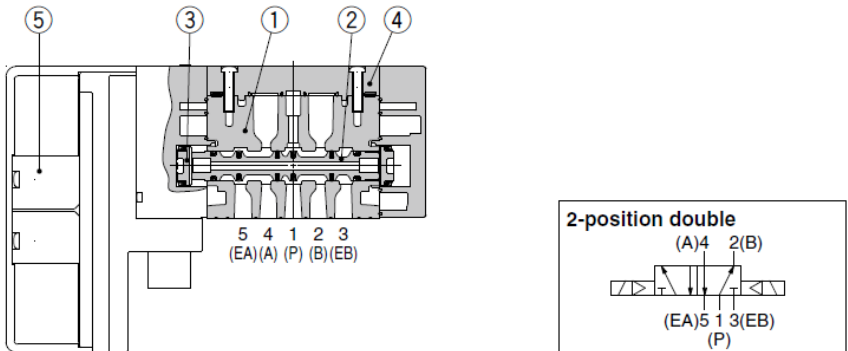

3-position closed center/exhaust center/pressure center

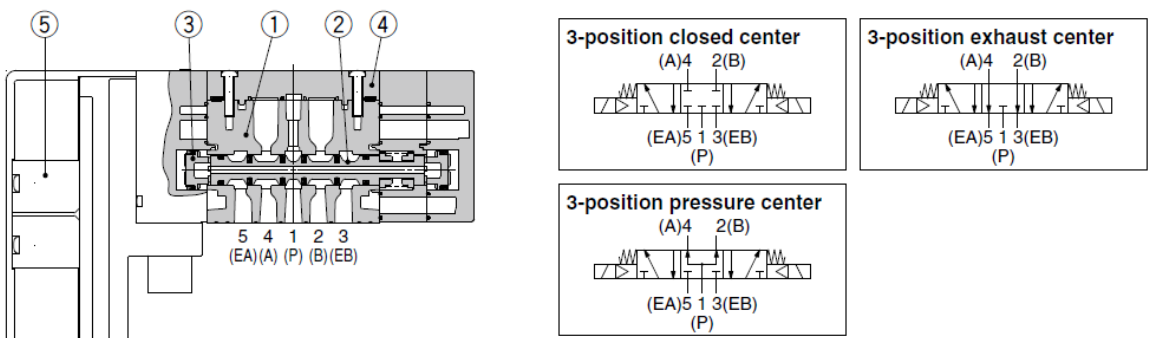

Component Parts

No.	Description	Material	Note
1	Body	SY3000: Zinc die-casted SY5000/SY7000: Aluminum die-casted	
2	Spool valve	Special resin/HNBR (3-position valve:) Aluminum/HNBR	
3	Piston	Resin	
	Body cover assembly	Resin	For side/bottom ported
4	Port block assembly	SY3000: Resin SY5000: Zinc die-casted SY7000: Aluminum die-casted	For top ported
5	Pilot valve assembly	—	Refer to page 145.

Rubber Seal

4-position dual 3-port valve

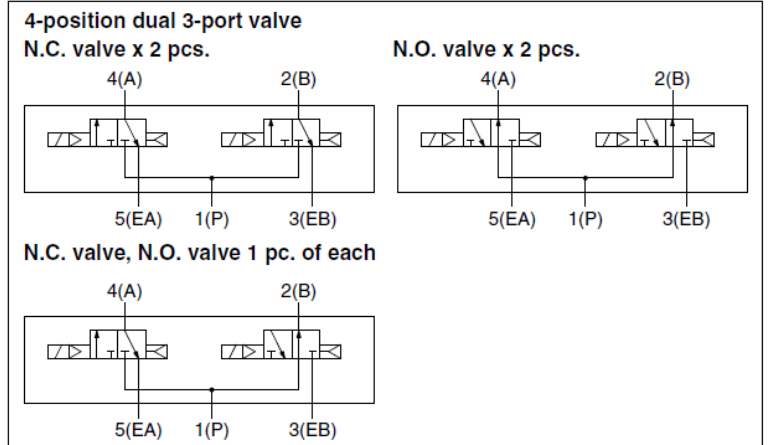
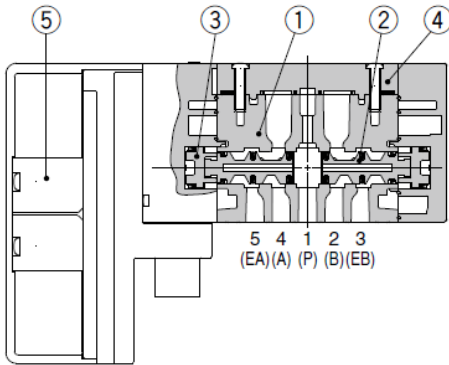

2-position double with back pressure check valve (Built-in valve type)

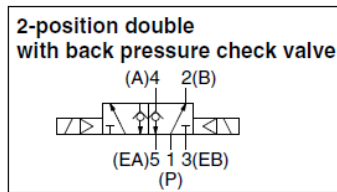
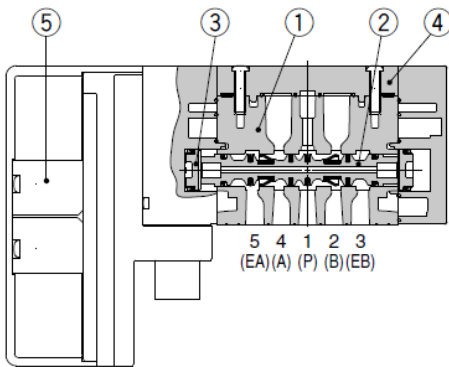

*: The built-in valve type back pressure check valve is not available for the SY7000.

4-position dual 3-port valve with back pressure check valve (Built-in valve type)

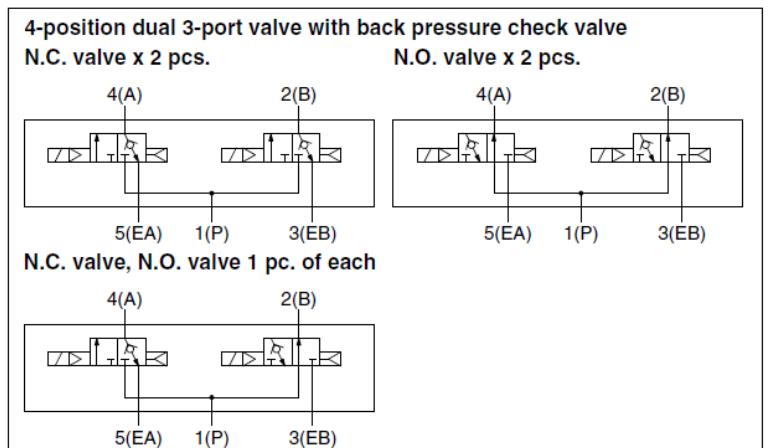
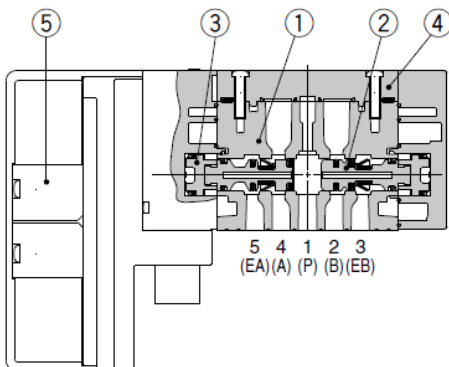

*: The built-in valve type back pressure check valve is not available for the SY7000.

Metal Seal

2-position single

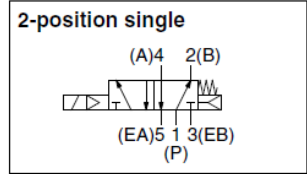
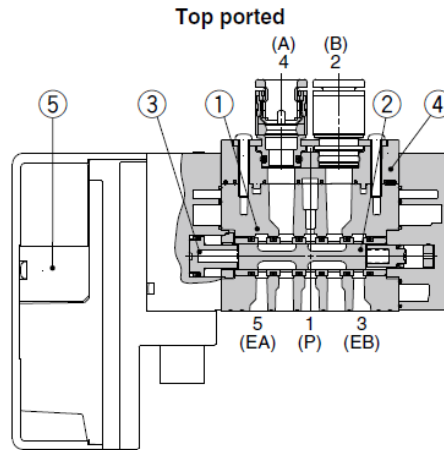
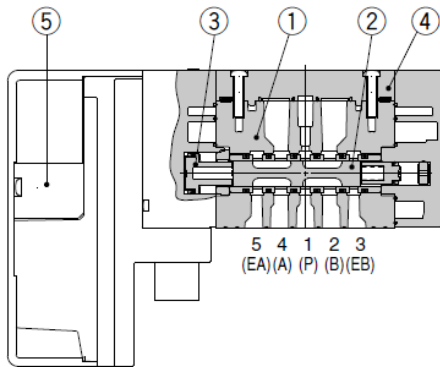

2-position double

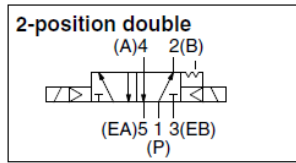
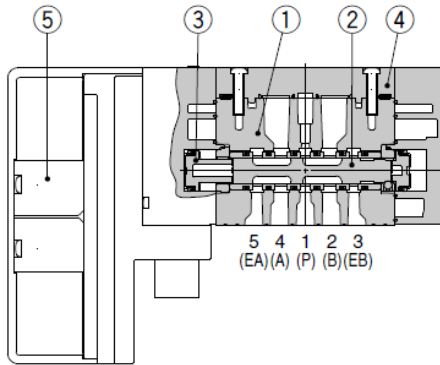

3-position closed center/exhaust center/pressure center

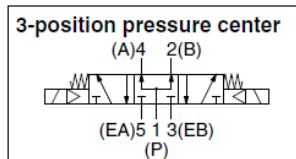
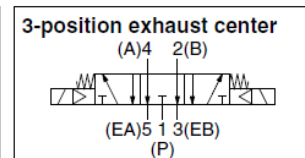
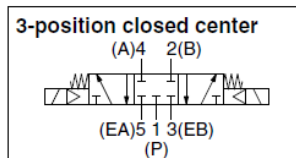
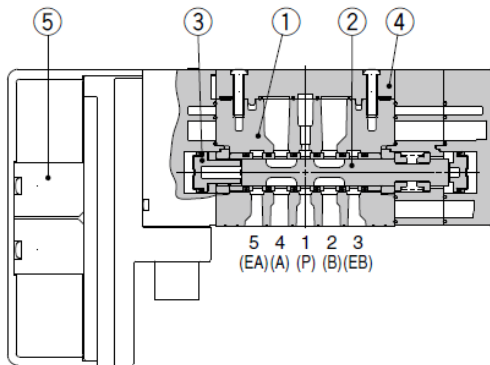

Component Parts

No.	Description	Material	Note
1	Body	SY3000: Zinc die-casted SY5000/SY7000: Aluminum die-casted	
2	Spool, Sleeve	Stainless steel/HNBR	
3	Piston	Resin	
4	Body cover assembly	Resin	For side/bottom ported
	Port block assembly	SY3000: Resin SY5000: Zinc die-casted SY7000: Aluminum die-casted	For top ported
5	Pilot valve assembly	—	Refer to page 145.

TROUBLESHOOTING

Should any trouble be found during operation, trace the source of the trouble in the following order and take corrective action.

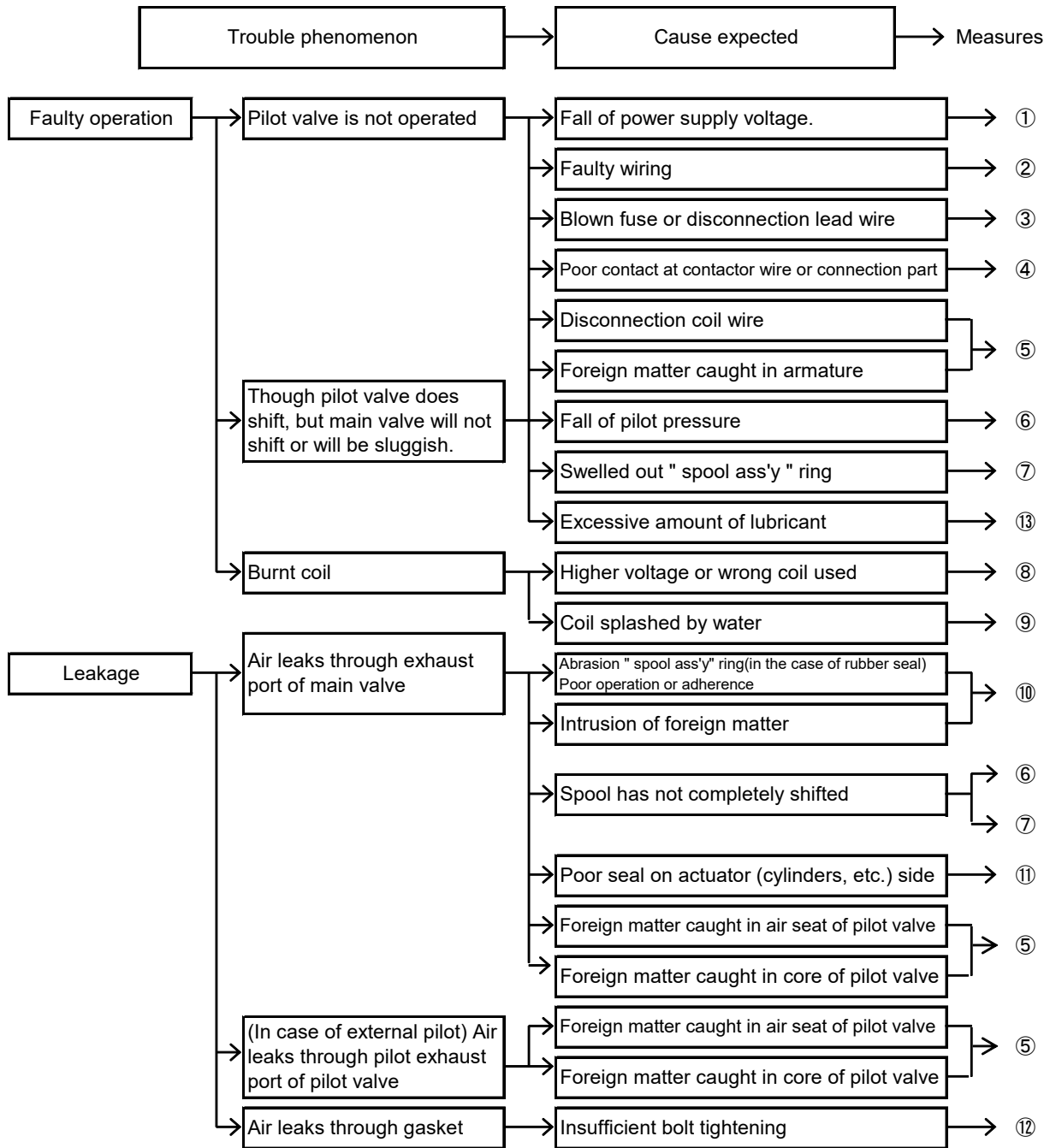

Remedy

No.	Remedy
①	Regulate voltage, so that the voltage at the time of the operation becomes specifications range.
②	Re-wire correctly.
③	Replace part.
④	Replace part or re-wire positively.
⑤	Replace valve.
⑥	Regulate pressure so that pilot pressure will fall within operating pressure range during operation.
⑦	· If wrong oil is used, completely air blow to remove oil, and replace valve. After valve is replaced, use turbine oil class 1 (ISO VG32). · When a large quantity of drain is given and cannot carry out drain omission surely, install either an auto-drain or a dryer. The valve should be replaced.
⑧	Check voltage. Replace valve (pilot valve).
⑨	Protect the valve so that water does not splash the coil. Replace valve (pilot valve).
⑩	In case of intrusion of foreign matter, to remove foreign matter by air blow of piping and then replace valve.
⑪	Repair or replace actuators.
⑫	After stopping air and re-tighten the bolts.
⑬	Reduce the amount of lubricant to the degree that no oil splashes out of the air exhaust (E) port.

If no improvement is achieved in spite of the above countermeasure, inside of the valve may have some abnormality. In this case, stop using the valve immediately.

If any of followings are carried out, inside of the valve may have some failure. In this case, stop using the valve immediately.

- ① Voltage out of rated voltage has been used.
- ② Oil other than the specified one has been lubricated.
- ③ Lubrication has been stopped intermediately, or lubrication was suspended temporary.
- ④ Water splashed directly.
- ⑤ Strong impact was given.
- ⑥ Alien substance such as drain and particle got into. Drain or garbage invaded a valve.
- ⑦ Prohibited way of using the valve which is written at "Precautions" section in this operation manual was carried out excluding above-mentioned.

In addition, in the case of trouble, please send it back to the supplier for repair or replacement.

Revision history

C	Renewal	2024.10
---	---------	---------

SMC Corporation

Tel: + 81 3 5207 8249 Fax: +81 3 5298 5362

URL <https://www.smcworld.com>

Note: Specifications are subject to change without prior notice and any obligation on the part of the manufacturer.
© SMC Corporation All Rights Reserved