



# Operation Manual

PRODUCT NAME

Condensation Checker  
(Digital Temperature & Humidity Switch)  
( IO-Link compatible)

MODEL / Series / Product Number

*PSH*

**SMC Corporation**

## Table of Contents

Safety Instructions	4
Model Indication and How to Order	12
Names and Functions of Product Parts	13
Definition and terminology	15
Mounting and Installation	18
Installation	18
Piping method	20
Wiring	22
Outline of Settings [Measurement mode]	25
Setting Relative Humidity and Temperature	27
3-Step Setting Mode	28
Simple Setting Mode	30
Function Selection Mode	32
Function selection mode	32
Default setting	32
F0 System setting	34
F1 OUT1 setting	35
F2 OUT2 setting	39
F3 Digital filter setting	42
F6 Display value fine adjustment setting	43
F10 Display setting	44
F11 Display resolution setting	51
F22 Analogue output setting	52
F50 Relative humidity OUT1 setting	53
F51 Relative humidity OUT2 setting	54
F52 Temperature OUT1 setting	55
F53 Temperature OUT2 setting	56
F80 Display off mode setting	57
F81 Security code input setting	58
F90 Setting of all functions	60
F96 Cycle time check	62
F98 Output check	63
F99 Reset to default setting	68
Other Settings	69

IO-Link Specifications	72
Summary of IO-Link function	72
Communication specification	72
Process data	73
IO-Link parameter setting	75
Maintenance	90
Forgot the Security Code	90
Troubleshooting	91
Specification	102
Dimensions	105



# Safety Instructions

These safety instructions are intended to prevent hazardous situations and/or equipment damage. These instructions indicate the level of potential hazard with the labels of “**Caution**,” “**Warning**” or “**Danger**.” They are all important notes for safety and must be followed in addition to International Standards (ISO/IEC)<sup>\*)</sup>, and other safety regulations.

\*) ISO 4414: Pneumatic fluid power - General rules and safety requirements for systems and their components  
ISO 4413: Hydraulic fluid power - General rules and safety requirements for systems and their components  
IEC 60204-1: Safety of machinery - Electrical equipment of machines - Part 1: General requirements  
ISO 10218-1: Robots and robotic devices - Safety requirements for industrial robots - Part 1: Robots  
etc.



## **Danger**

**Danger** indicates a hazard with a high level of risk which, if not avoided, will result in death or serious injury.



## **Warning**

**Warning** indicates a hazard with a medium level of risk which, if not avoided, could result in death or serious injury.



## **Caution**

**Caution** indicates a hazard with a low level of risk which, if not avoided, could result in minor or moderate injury.



## **Warning**

### **1. The compatibility of the product is the responsibility of the person who designs the equipment or decides its specifications.**

Since the product specified here is used under various operating conditions, its compatibility with specific equipment must be decided by the person who designs the equipment or decides its specifications based on necessary analysis and test results. The expected performance and safety assurance of the equipment will be the responsibility of the person who has determined its compatibility with the product. This person should also continuously review all specifications of the product referring to its latest catalog information, with a view to giving due consideration to any possibility of equipment failure when configuring the equipment.

### **2. Only personnel with appropriate training should operate machinery and equipment.**

The product specified here may become unsafe if handled incorrectly. The assembly, operation and maintenance of machines or equipment including our products must be performed by an operator who is appropriately trained and experienced.

### **3. Do not service or attempt to remove product and machinery/equipment until safety is confirmed.**

1. The inspection and maintenance of machinery/equipment should only be performed after measures to prevent falling or runaway of the driven objects have been confirmed.
2. When the product is to be removed, confirm that the safety measures as mentioned above are implemented and the power from any appropriate source is cut, and read and understand the specific product precautions of all relevant products carefully.
3. Before machinery/equipment is restarted, take measures to prevent unexpected operation and malfunction.

### **4. Our products cannot be used beyond their specifications. Our products are not developed, designed, and manufactured to be used under the following conditions or environments. Use under such conditions or environments is not covered.**

1. Conditions and environments outside of the given specifications, or use outdoors or in a place exposed to direct sunlight.
2. Use for nuclear power, railways, aviation, space equipment, ships, vehicles, military application, equipment affecting human life, body, and property, fuel equipment, entertainment equipment, emergency shut-off circuits, press clutches, brake circuits, safety equipment, etc., and use for applications that do not conform to standard specifications such as catalogs and operation manuals.
3. Use for interlock circuits, except for use with double interlock such as installing a mechanical protection function in case of failure. Please periodically inspect the product to confirm that the product is operating properly.



# Safety Instructions

## Caution

**We develop, design, and manufacture our products to be used for automatic control equipment, and provide them for peaceful use in manufacturing business.**

**Use in non-manufacturing business is not covered.**

Products we manufacture and sell cannot be used for the purpose of transactions or certification specified in the Measurement Act.

The new Measurement Act prohibits use of any unit other than SI units in Japan.

## Limited warranty and Disclaimer/Compliance Requirements

The product used is subject to the following “Limited warranty and Disclaimer” and “Compliance Requirements”.

Read and accept them before using the product.

### Limited warranty and Disclaimer

1. The warranty period of the product is 1 year in service or 1.5 years after the product is delivered, whichever is first.\*2)  
Also, the product may have specified durability, running distance or replacement parts. Please consult your nearest sales branch.
2. For any failure or damage reported within the warranty period which is clearly our responsibility, a replacement product or necessary parts will be provided.  
This limited warranty applies only to our product independently, and not to any other damage incurred due to the failure of the product.
3. Prior to using SMC products, please read and understand the warranty terms and disclaimers noted in the specified catalog for the particular products.

**\*2) Vacuum pads are excluded from this 1 year warranty.**

A vacuum pad is a consumable part, so it is warranted for a year after it is delivered.

Also, even within the warranty period, the wear of a product due to the use of the vacuum pad or failure due to the deterioration of rubber material are not covered by the limited warranty

### Compliance Requirements

1. The use of SMC products with production equipment for the manufacture of weapons of mass destruction (WMD) or any other weapon is strictly prohibited.
2. The exports of SMC products or technology from one country to another are governed by the relevant security laws and regulations of the countries involved in the transaction. Prior to the shipment of a SMC product to another country, assure that all local rules governing that export are known and followed.

## Operator

- ◆ This operation manual is intended for those who have knowledge of machinery using pneumatic equipment, and have sufficient knowledge of assembly, operation and maintenance of such equipment. Only those persons are allowed to perform assembly, operation and maintenance.
- ◆ Read and understand this operation manual carefully before assembling, operating or providing maintenance to the product.

### ■ Safety Instructions

#### **Warning**

- Do not disassemble, modify (including changing the printed circuit board) or repair.  
An injury or failure can result.
- Do not operate the product outside of the specifications.  
Do not use for flammable or harmful fluids.  
Fire, malfunction, or damage to the product can result.  
Verify the specifications before use.
- Do not operate in an atmosphere containing flammable or explosive gases.  
Fire or an explosion can result.  
This product is not designed to be explosion proof.
- Do not use the product in a place where static electricity is a problem.  
Otherwise it can cause failure or malfunction of the system.
- If using the product in an interlocking circuit:
  - Provide a double interlocking system, for example a mechanical system
  - Check the product regularly for proper operationOtherwise malfunction can result, causing an accident.
- The following instructions must be followed during maintenance:
  - Turn off the power supply
  - Stop the air supply, exhaust the residual pressure and verify that the air is released before performing maintenanceOtherwise an injury can result.

## Caution

- Do not touch the terminals and connectors while the power is on.  
Otherwise electric shock, malfunction or damage to the product can result.
- After maintenance is complete, perform appropriate functional inspections and leak tests.  
Stop operation if the equipment does not function properly or there is a leakage of fluid.  
When leakage occurs from parts other than the piping, the product might be faulty.  
Disconnect the power supply and stop the fluid supply.  
Do not apply fluid under leaking conditions.  
Safety cannot be assured in the case of unexpected malfunction.

### ■ Precautions for handling

- Follow the instructions given below for selecting and handling the temperature & humidity switch.
  - The instructions on design and selection (installation, wiring, operating environment, adjustment, operation, maintenance, inspection, etc.) described below must be followed.
    - \*Product specifications, etc.
    - Use within the specified voltage.  
Otherwise, it may cause failure or malfunction.
    - Do not apply a load that exceeds the max. load voltage or current.  
Otherwise, it can damage or shorten the life of the temperature & humidity switch.
    - Design the product to prevent reverse current when the circuit is open or the product is forced to operate for operational checks.  
Reverse current can cause product damage or malfunction.
    - Data input to the temperature & humidity switch will not be deleted even if the power supply is cut off.  
(Write limit: 10,000 cycles, Data duration: 20 years after power off).
    - Use clean air.  
Otherwise, it may cause operation failure.  
If air-containing condensate is used, install an air dryer or water separator before the filter and perform draining regularly.  
If draining is not performed regularly and condensate enters the secondary side of the product, it can cause operation failure of pneumatic equipment.  
If draining is difficult, the installation of a filter with an auto drain is recommended.
    - Air and non-corrosive gas can be used.  
Do not use a fluid containing chemicals, synthetic oils including organic solvent, salt, or corrosive gases.  
Mixture of these substances may cause damage or operation failure of the temperature & humidity switch.  
Check the specification details before use.
    - Use within the specified measurement flow rate and operating pressure.  
Otherwise, it may damage the temperature & humidity switch and may not allow correct measurement.
    - Secure a space for maintenance.  
Design the system to allow space necessary for maintenance.

## ●Product Handling

### \*Mounting

- Conform to the specified tightening torque.

If the tightening torque is exceeded, the mounting screws, mounting bracket, temperature & humidity switch, and other parts may be damaged.

Insufficient tightening torque may cause loosening of the mounting screws and displacement of the product .

- Do not apply excessive stress to the temperature & humidity switch when mounted using a panel mount adapter.

Otherwise, it may damage the product or may fall off from the panel mounting.

- If a commercially available switching power supply is used, be sure to connect the frame ground (FG) terminal to ground.

- Do not drop, hit, or apply excessive shock to the product.

Otherwise, the internal parts of the temperature & humidity switch may be damaged and cause malfunction.

- Do not pull the lead wire with force or lift the product by pulling the lead wire. (Tensile strength 35 N or less)

Hold the product body when handling.

Otherwise, the product may be damaged, leading to failure and malfunction.

- When connecting the temperature & humidity switch, apply a spanner to the hexagonal part only.

Holding other parts of the product with a spanner may damage the product.

- Eliminate any dust left in the piping by air blow before connecting the piping to the temperature & humidity switch.

Otherwise, it can cause damage or malfunction.

- Do not insert metal wires or other foreign objects into the exhaust port.

Otherwise, the temperature & humidity sensor may be damaged leading to failure and malfunction.

- Never mount the temperature & humidity switch in a place that will be used as a mechanical support.

Otherwise, the product may be damaged if excessive force is applied by stepping or climbing onto it.

- If the fluid contains foreign matter, install and connect a filter or mist separator to the upstream side (inlet side).

Otherwise, it can cause damage or malfunction. Or the temperature & humidity switch may not allow accurate measurement.

It is possible to satisfy the air quality class indicated in the specification using the pneumatic circuit below.

### Recommended pneumatic circuit example

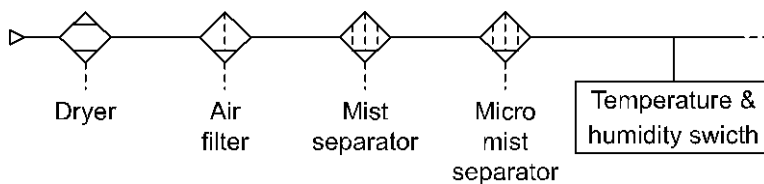



- Pay attention to the mounting direction restrictions.

<Mounting>

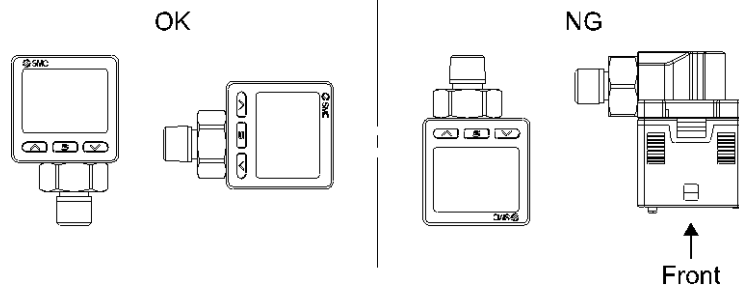

- Do not separate the fluid to be measured from the installation position of the temperature & humidity switch.

Measurement accuracy and responsiveness performance is reduced.

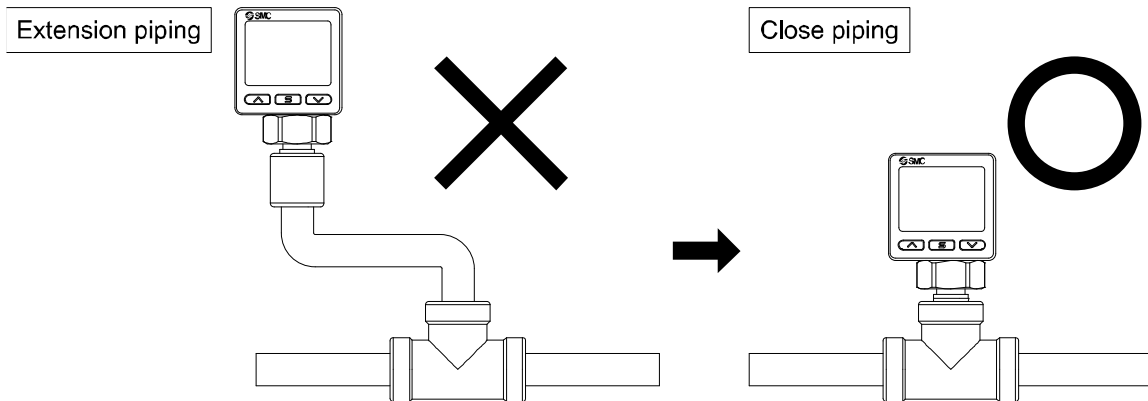

\*Wiring (Including connecting/disconnecting the connectors)

- Do not pull hard on the lead wire. In particular, never lift the temperature & humidity switch by the lead wire.  
Otherwise, the internal parts of the product may be damaged causing malfunction or detachment of the connector.
- Avoid repeatedly bending, stretching, or applying a heavy force to the lead wire.  
Repetitive bending or tensile stress can cause the sheath of the wire to peel off.  
If the lead wire can move, fix it near the product.  
The recommended bend radius of the lead wire is 6 times the outside diameter of the sheath, or 33 times the outside diameter of the insulation material, whichever is larger.  
Replace any damaged lead wire with a new one.
- Wire correctly.  
Incorrect wiring can cause malfunction or damage to the temperature & humidity switch.
- Do not perform wiring while the power is on.  
Otherwise, the internal parts of the product may be damaged and cause malfunction.
- Do not route wires and cables together with power or high voltage cables.  
Route the wires of the temperature & humidity switch separately from power or high voltage cables in order to avoid noise or surge entering the signal lines.
- Check that the wiring is properly insulated.  
Poor insulation (interference with other circuits, poor insulation between terminals etc.) can apply excessive voltage or current to the temperature & humidity switch and cause damage.
- Design the system to prevent reverse current when the product is performing an operational check.  
Depending on the circuit used, insulation may not be maintained and reverse current may be applied, which will cause the switch to malfunction or be damaged.
- Keep wiring as short as possible to prevent interference from electromagnetic noise and surge voltage.  
Wiring length should be kept to 20 m or less.  
Wire the DC (-) line (blue) as close as possible to the power supply.

**\*Operating environment**

- Do not use in an atmosphere with corrosive gases, chemicals, sea water, water, water steam, or where there is direct contact with any of these.  
Otherwise, it may cause failure or malfunction.
- Do not store in closed conditions with organic gases, high humidity atmospheres or without air exchange.  
(Store in a well-ventilated environment)  
Otherwise, it can cause damage or malfunction.
- Do not use the product in a place where the product could be splashed by oil or chemicals.  
If the product is to be used in an environment containing oils or chemicals such as coolant or cleaning solvent, even for a short time, the product may be adversely affected (damage, malfunction, or hardening of the lead wires).
- Do not use in an area where surges are generated.  
When there are machines or equipment that generate large surges near the temperature & humidity switch (magnetic type lifter, high-frequency inductive furnace, motor, etc.), this can result in deterioration and damage to the internal elements. Take measures against the surge sources, and prevent the lines from coming into close contact with the product.
- Do not apply a load that generates a surge voltage.  
When a surge-generating load such as a relay or solenoid is to be directly driven, use a product with built-in surge protection.
- The product is CE/UKCA marked, however, it is not immune to lightning strikes. Take measures against lightning strikes in the system.
- Mount the temperature & humidity switch in a place that is not affected by vibration or impact.  
Otherwise, it can cause damage or malfunction.
- Do not let foreign matter, such as wire debris, get inside the product.  
In order to avoid failure and malfunction, do not let foreign matter, such as wire debris, get inside the temperature & humidity switch.
- Do not use the product in an environment that is exposed to temperature cycles.  
Temperature cycles other than normal temperature changes can adversely affect the temperature & humidity switch internally.
- Do not expose to direct sunlight.  
If using in a location directly exposed to sunlight, shade the product from the sunlight.  
Otherwise, it can cause damage or malfunction.
- Keep within the operating fluid temperature and ambient temperature range.  
The operating fluid and ambient temperature range is 0 to 50°C. Operation at low temperature (5°C or less) may cause damage or operation failure due to frozen moisture in the air.  
Protection against freezing is necessary. Mounting of an air dryer is recommended for the elimination of drainage and water.  
Avoid abrupt temperature changes even within the specified temperature range.
- Do not use in a location where the product is exposed to radiant heat from surrounding heat sources.  
Otherwise, it may cause operation failure.

### \*Adjustment and Operation

- Connect the load before turning the power supply on.

If the power supply is turned on with no load connected to the temperature & humidity switch, over current may occur, causing the product to fail instantly.

- Do not short-circuit the load.

Although an error is displayed when the load of the temperature & humidity switch has a short circuit, the generated over current may damage the product.

- Do not press the setting buttons with a sharp pointed object.

Otherwise, it may damage the setting buttons.

- Allow the product to warm up for 10 to 15 minutes after an air flow is introduced.

The display fluctuates until the temperature becomes stable.

- Relative humidity is measured at atmospheric pressure, so conversion is required if you want to know the relative humidity under pressure in the piping.

- Provide settings suitable for the operating conditions.

Incorrect setting can cause operation failure.

Refer to pages 25 to 71 for various settings.

- Do not touch the LCD display area during operation.

The display can vary due to static electricity.

- Do not block the exhaust port.

Because of air purging, if the exhaust port is blocked, measurement cannot be taken properly.

Keep the exhaust port released to atmosphere. Otherwise, it can cause failure or malfunction.

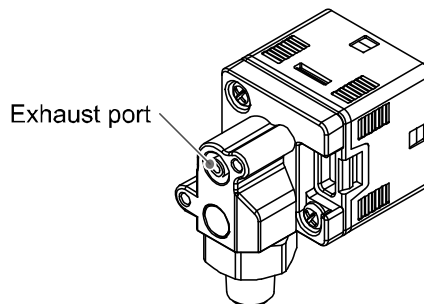

### \*Maintenance

- Before performing maintenance, turn off the power supply, stop the air supply, exhaust the residual compressed air in the piping, and verify the release of air.

Otherwise, it can cause unexpected malfunction in the components.

- Perform regular maintenance.

Otherwise, it can cause unexpected failure of components due to the malfunction of equipment and machinery.

- Remove the condensate periodically.

If condensate enters the secondary side, it can cause operating failure of pneumatic equipment.

- Do not use organic solvents such as benzene, thinner, ethanol, etc. to clean the product.

Otherwise, it can cause damage or malfunction.

Otherwise, it can damage the surface or erase the product markings.

Use a soft cloth to remove stains.

## Model Indication and How to Order

PSH - **L2** - **M** - 01 -

### Output specification

Symbol	Description
L2	IO-Link/Switch output 1 + Switch output 2 (Switch output can be selected, NPN or PNP.)
RT	Switch output 1 + Switch output 2 + Analogue voltage output (Switch output can be selected, NPN or PNP.)

\*1: Switch output 1/2 and analogue voltage output can be selected to relative humidity or temperature.

### Unit specification

Symbol	Description
Nil	With unit selection function *2
M	SI unit fixed *3

\*2: The unit selection function is not for use in Japan due to a measurement law. A units label is supplied.

\*3: Fixed unit %R.H., °C

### Piping specification

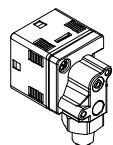
Symbol	Description
01	R1/8 

### Option 3

Symbol	Description
Nil	Operation Manual
Y	None

### Option 2

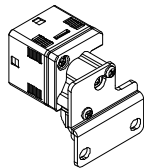
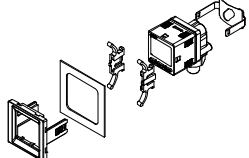
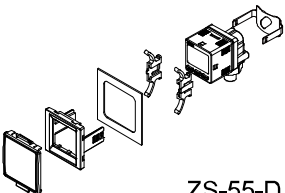
Symbol	Description
Nil	None
A	Bracket  ZS-55-A
B	Panel mount adapter  ZS-55-B
D	Panel mount adapter + Front protective cover  ZS-55-D

### Option 1

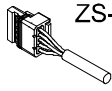
Symbol	Description
Nil	None
W	Lead wire with connector (2 m, waterproof)  ZS-46-5F

### ○Accessories/Part number

If an accessory is required independently, order using the following part numbers.

Description	Part number	Remarks
Bracket	ZS-55-A	-
Panel mount adapter	ZS-55-B	-
Panel mount adapter + Front protective cover	ZS-55-D	-
Lead wire with connector	ZS-46-5F	5 cores, 2 m, waterproof
Front protective cover	ZS-35-01	-
Sintered metal filter element	EBD-3.8-3-2	Minimum purchase quantity: 10

## Names and Functions of Product Parts

### Parts Names

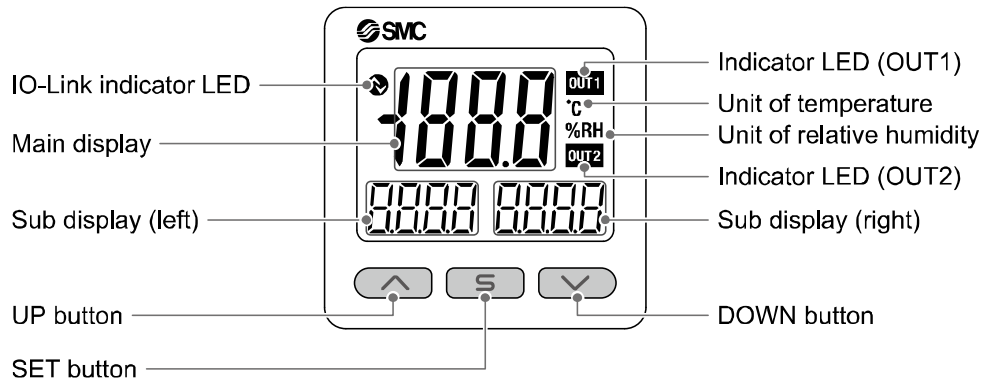

**Indicator LED:** Displays the switch operating condition.

**Main display:** Displays relative humidity measurement value, temperature measurement value, error code, etc. (2-colour display).

**Sub display (left):** Displays a value item (Orange).

**Sub display (right):** Displays relative humidity measurement value, temperature measurement value, setting value, and peak/bottom value (Orange).





**UP button:** Increases the mode and ON/OFF set values.



**DOWN button:** Decreases the mode and ON/OFF set values.

**SET button:** Changes the mode and confirms the settings.

**IO-Link indicator LED:** Displays OUT1 output communication status (SIO mode, start-up mode, Pre-operation mode, operation mode) and the presence of communication data.

●IO-Link indicator LED operation and display

Communication with the master	IO-Link indicator LED	Status		Indication in sub display *1	Details	
						
Yes		IO-Link mode	Normal	Operation	node oPE	Normal communication status (Reading of measurement value)
				Start up	node StEt	At the start of communication
				Preoperation	node PrE	
	Abnormal		The version does not match	Er 5 u 10	IO-Link version does not match with the master setting *2	
Locked		node LoL	Backup and restore request during data storage lock			
No		SIO mode	Communication shut-off	node oPE node StEt node PrE	Normal communication was not received for more than 1 second.	
				General switch output		

LCD display: "O" off, "" flash, "" on

\*1: "ModE - - -" is displayed when selecting the modes on the sub display.

\*2: An error will be displayed when the product is connected to the IO-Link master version "V1.0."

## ■ Definition and terminology

	Term	Definition
B	Bottom value display (mode)	The minimum relative humidity and temperature recorded from when the power was supplied to the present time.
C	Chattering	Phenomenon of the switch output turning ON and OFF repeatedly at high frequencies.
D	Digit (smallest settable increment)	Shows how precisely the relative humidity and temperature can be displayed or set by the digital temperature & humidity switch. When 1 digit = 0.1% R.H., the pressure is displayed in increments of 0.1% R.H. e.g., 0.1, 0.2, 0.3, ..., 9.9, 10.0 Also known as resolution.
	Digital filter	Function to add digital filtering to the fluctuation of the temperature & humidity sensor output. It moderates the fluctuation of displayed value for sharp increase or decrease. When the function is used, digital filtering is reflected in the ON/OFF of the switch output. Output chattering or flicker in the measurement mode display can be reduced by setting the digital filter.
	Display accuracy	Indicates the maximum deviation between the displayed relative humidity and temperature value and the true relative humidity and temperature.
	Display colour	Indicates the colour of the digits on the digital display. Always white, always red, white (switch OFF) changing to red (switch ON), or red (switch OFF) changing to white (switch ON) are available in window comparator mode.
	Display off mode	The values will not be displayed.
	Display resolution	Indicate in how many divisions the rated relative humidity and temperature range can be displayed. (Example: When the value can be displayed by the increment of 0.1% R.H. for 0 to 100% R.H., the resolution will be 1/1000.)
	Display value fine adjustment (function)	Displayed relative humidity and temperature can be adjusted within the range of $\pm 5\%$ R.D. ( $\pm 5\%$ of displayed value). It is used if the true relative humidity and temperature are known, or to eliminate differences between the displayed values of different instruments that are measuring the same relative humidity and temperature.
	E	Error indication
Error output		Switches the switch output to ON/OFF when an error is displayed. Refer to "List of output modes" on page 38 for details of operating conditions. Refer to "Error display function" on page 100 for details of error codes.
F	Fine adjustment mode	Refer to "Display value fine adjustment (function)."
	Function selection mode	A mode in which setting of functions is performed. It is a separate menu from the relative humidity and temperature setting. If any function settings need to be changed from the factory default, each setting can be selected with "F*." The setting items are: operation mode, output type, display colour, digital filter, display value fine adjustment, display indication, display resolution, use of display off mode, and use of security code.

	Term	Definition
H	Hysteresis	Difference between the ON and OFF points of the temperature & humidity switch. Also called differential travel.
	Hysteresis mode	Refer to "List of output modes" on page 38.
I	Insulation resistance	Insulation resistance of the product. The resistance between the electrical circuit and the enclosure.
K	Key-lock function	Function that prevents changes to the settings of the temperature & humidity switch (disables button operation).
M	Maximum applied voltage	The maximum voltage that can be connected to the output of an NPN device.
	Maximum load current	The maximum current that can be applied to the switch output.
	Measurement mode	Operating condition in which the relative humidity and temperature are detected and displayed, and the switch function is operating.
N	Normal output	One of the switch output types. In hysteresis mode, the switch output is turned ON when relative humidity and temperature equal to or greater than the switch output set value is detected. (Hysteresis mode) In window comparator mode, the switch output is turned ON when relative humidity and temperature between the switch output set values (P1L to P1H) are detected. (Refer to "List of output modes" on page 38.)
O	Operating mode	Hysteresis mode, window comparator mode, error output, or output off can be selected.
	Operating pressure range	Available pressure range.
	Operation LED	A light that turns ON when the switch output is ON.
	Output type	The operation principle of the switch output. Normal output and reverse output can be selected. Refer to "List of output modes" on page 38 for details of operating conditions.
	Peak value display (mode)	The maximum relative humidity and temperature recorded from when the power was supplied to the present time.
	Port size	The diameter of the connecting part of the switch for connecting with the object to be measured.
R	R.D.	The value currently displayed. For example, when the displayed value is 25% R.H., $\pm 5\%$ R.D. is $\pm 5\%$ of 25% R.H., which is $\pm 1.25\%$ R.H.
	Rated pressure range	The pressure range within which the product will meet all published specifications. Values outside of this range can be set as long as they are within the set pressure range, but the specifications cannot be guaranteed.
	Rated temperature range	The temperature range that meets the product specifications. Values outside of this range can be set as long as they are within the setting display range, but the specifications cannot be guaranteed.
	Residual voltage	The difference between the ideal ON voltage and the actual voltage when the switch output is on. Varies with load current. Ideally should be 0 V.
	Resolution	Refer to "Display resolution."
	Ripple	A type of chattering.
	Reverse output	One of the switch output types. In hysteresis mode, the switch output is turned ON when relative humidity and temperature less than or equal to the switch output set value is detected. (Hysteresis mode) In window comparator mode, the switch output is turned ON when relative humidity and temperature outside the switch output set values (n1L to n1H) are detected. (Refer to "List of output modes" on page 38).



	Term	Definition
S	Set relative humidity and temperature range	The switch output range that can be set for relative humidity and temperature.
	Setting relative humidity and temperature	The set relative humidity and temperature that determine the point at which the humidity & temperature switch turns ON and OFF.
	Smallest settable increment	Refer to "Digit." Also known as resolution.
	Switch output	Also referred to as "ON-OFF output."
U	Units selection function	A function to change the units of the temperature display. The display units can only be changed if the product is equipped with a unit conversion function. It is not possible to purchase the product intended for use in Japan with a unit conversion function. The product for Japan is displayed in SI units only.
W	Window comparator mode	An operating mode in which the switch output is maintained when the relative humidity and temperature are within the set range. (Refer to "List of output modes" on page 38.)
	Withstand voltage	A measure of the product's resistance to a voltage applied between the electrical circuit and the enclosure. The product may get damaged if a voltage over this value is applied. (The withstand voltage is not the supply voltage for operating the product).

# Mounting and Installation

## ■ Installation

### ○ How to mount

- Note that there are restrictions on installation direction and operating environment.
- Do not block the exhaust port.
- Mount the product using the optional bracket or the panel mount adapter.
- When installing at a location exposed to water or dust, insert a tube (purchased separately) in the exhaust port and extend it to a safe location not exposed to water or dust.  
(Refer to "Tube attachment" in page 21.)

### ○ Mounting with bracket

- Mount the bracket to the body using the mounting screws of M3 x 6L (2 pcs).

\*: Tighten the bracket mounting screws to a torque of  $0.5 \pm 0.05 \text{ N}\cdot\text{m}$ .

- Bracket (Part No.: ZS-55-A)

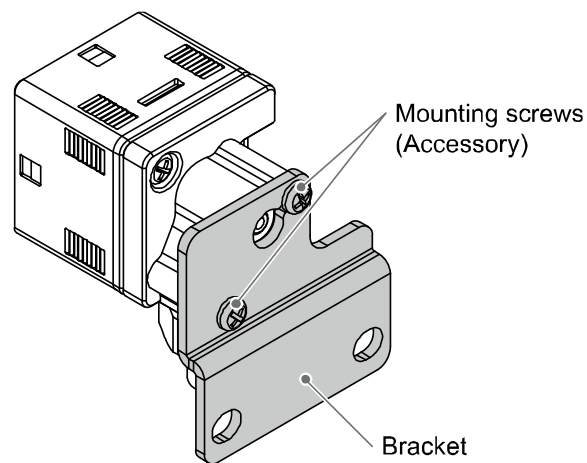

○ Mounting with panel mount adapter

- Fix into the panel by placing it between the panel mount adapters A and B, insert the temperature & humidity switch and mounting bracket, and secure it.

- Panel mount adapter (Part No.: ZS-55-B)

Panel mount adapter + Front protective cover (Part No.: ZS-55-D)

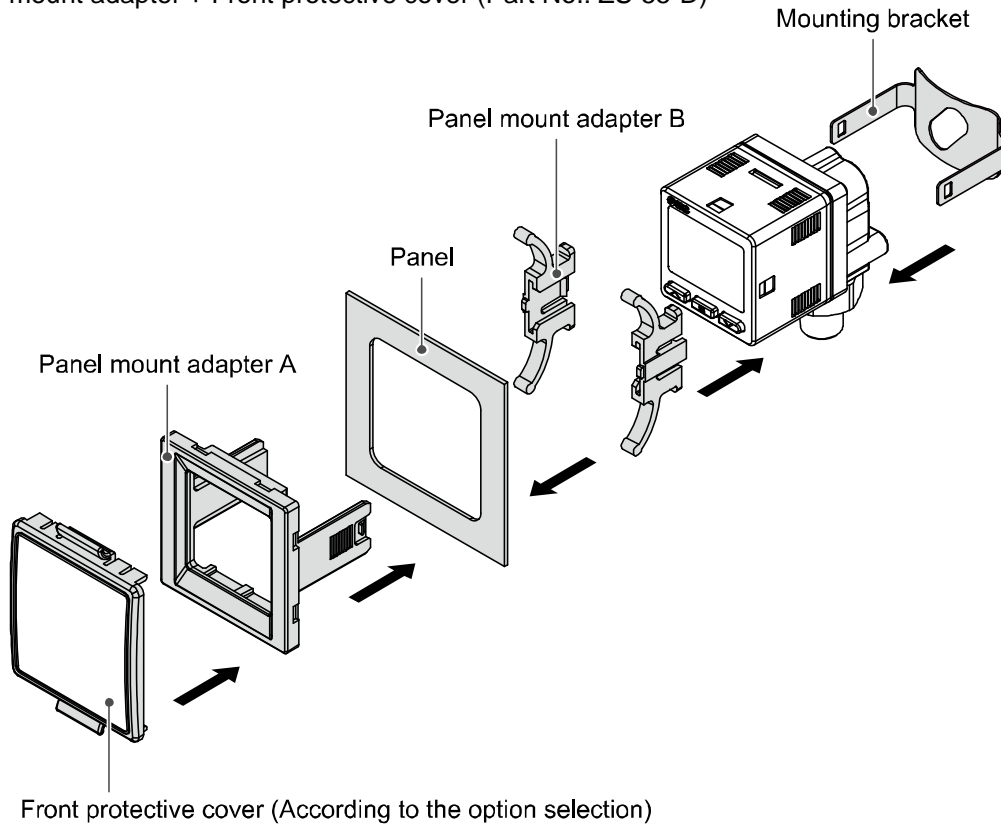

## ■Piping method

### ○Tightening the connection thread

#### ●For connecting to the product

For piping, use a piping material suitable for the piping port.

After hand tightening, apply a spanner of the correct size to the spanner flats of the body, and tighten by rotating 2 to 3 turns.

As a reference value, the tightening torque is 3 to 5 N•m.

When using the M5 female thread, check the specifications of the pipe fitting.

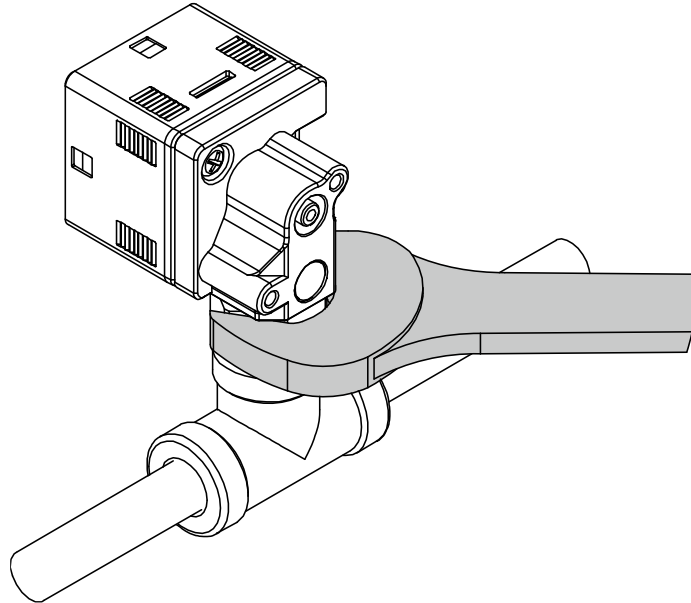

When tightening, do not hold the product body with a spanner.

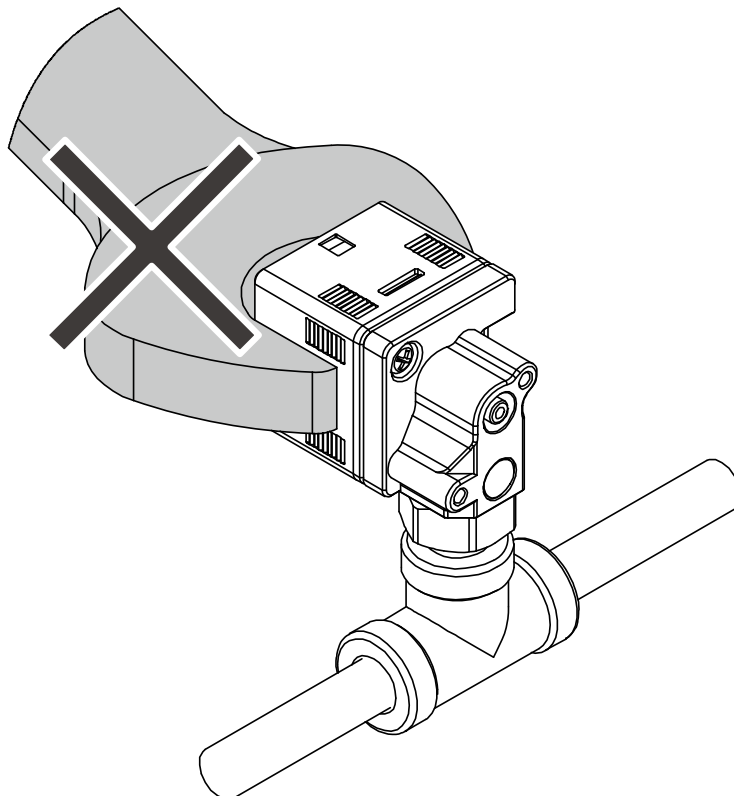

### ○Tube attachment

- When the exhaust port of the switch could get clogged by water or dust, insert a tube (sold separately) in the exhaust port to the bottom and extend the other end to a secure location where it is not exposed to water or dust.

(Refer to the diagram below)

- \*: Make sure to check that the exhaust port is always set to an atmospheric release condition.
- \*: Check that the tube is inserted to the bottom of the exhaust port.
- \*: For the tube, use TU0604 (polyurethane material, outside diameter  $\phi 6$ , inside diameter  $\phi 4$ ) from SMC.

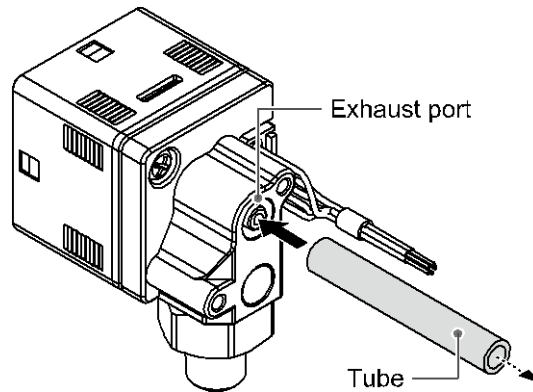

Extend to a secure location not exposed to water or dust.

### ○Maintenance of sintered metal filter element

- When the sintered metal filter element has been clogged by foreign matter, etc., remove the hexagon holding screw and replace the sintered metal filter element (Refer to the diagram below).

- \*: Pay attention not to scratch the fixed orifice of the fitting when removing the filter.
- \*: When assembling, insert the sintered metal filter element and hexagon holding screw and tighten it with a tightening torque of 0.45 to 0.55 N·m.
- \*: Do not use the product without installing the sintered metal filter element.

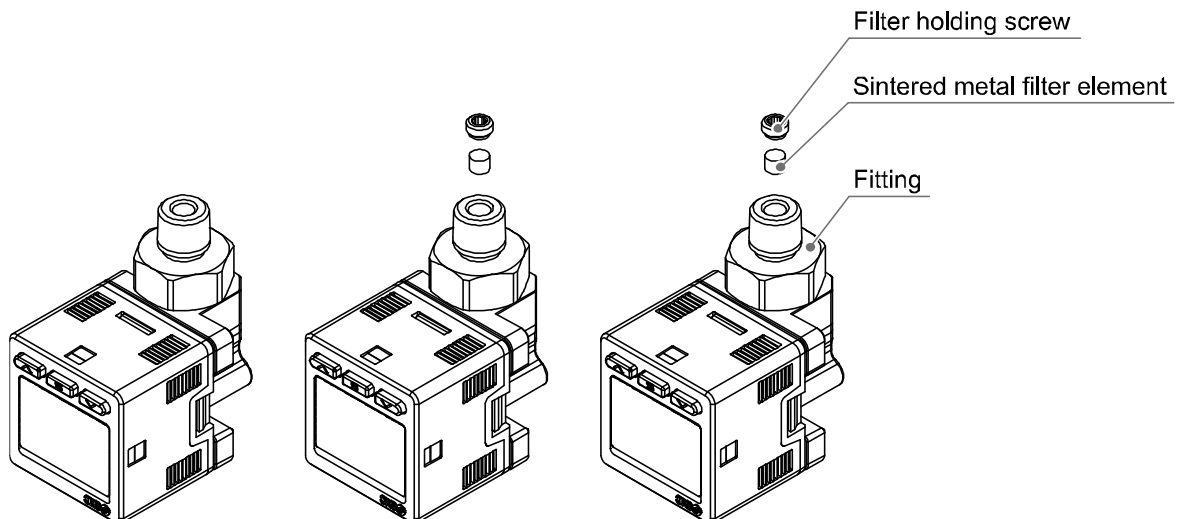

## ■Wiring

### ○Wiring connection

- Connections should be made with the power supply turned off.
- Use a separate route for the wiring. Routing wires and cables together with power or high voltage cables may cause malfunction due to noise.
- If a commercially available switching power supply is used, be sure to connect the frame ground (FG) terminal to ground. Switching noise will be superimposed and it will not be able to meet the product specifications. In that case, insert a noise filter such as a line noise filter/ferrite between the switching power supplies or change the switching power supply to a series power supply.

### ○How to Use Connector

#### Connector attachment/detachment

- When connecting the connector, insert it straight onto the pins holding the lever and connector body, and lock the connector by pushing the lever hook into the groove on the housing.
- To detach the connector, remove the hook from the groove by pressing the lever downward, and pull the connector straight out.

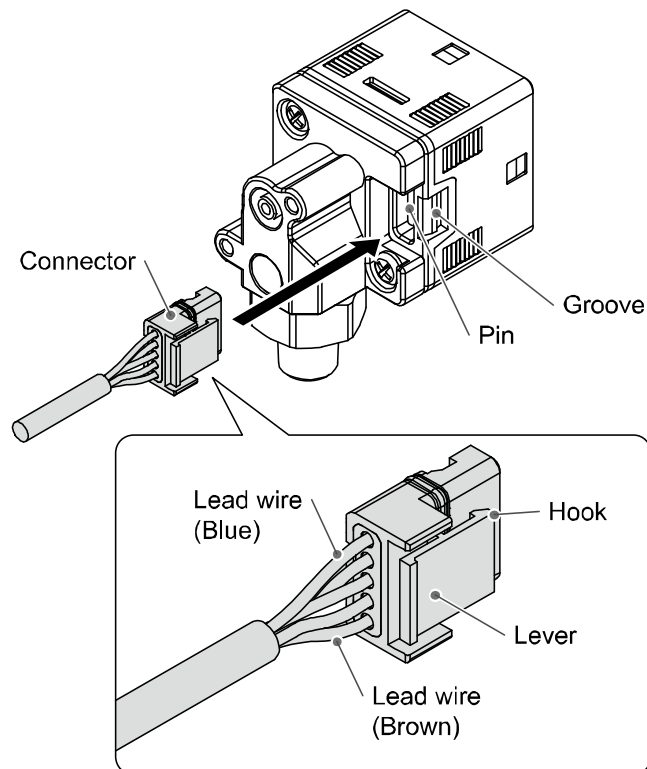

#### Connector pin No.

Output specification: For L2 (IO-Link + 1 output)

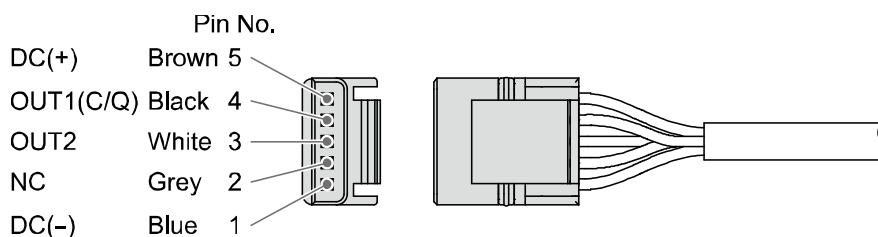

Output specification: For RT (2 output + Analogue voltage output)

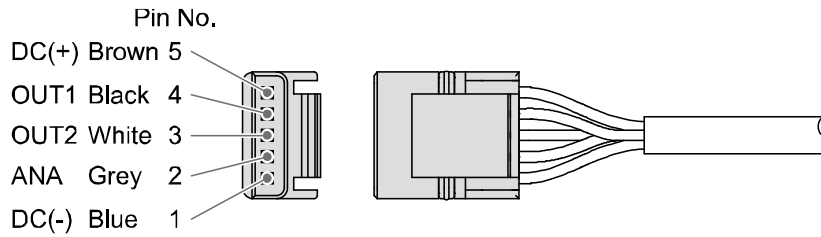

Internal circuit and wiring examples

-L2: IO-Link/switch output 1 + switch output 2  
When used as a switch output device

For NPN open collector 2 output setting

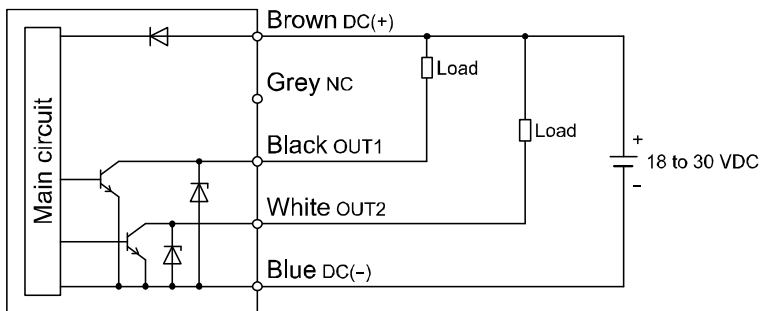

For PNP open collector 2 output setting

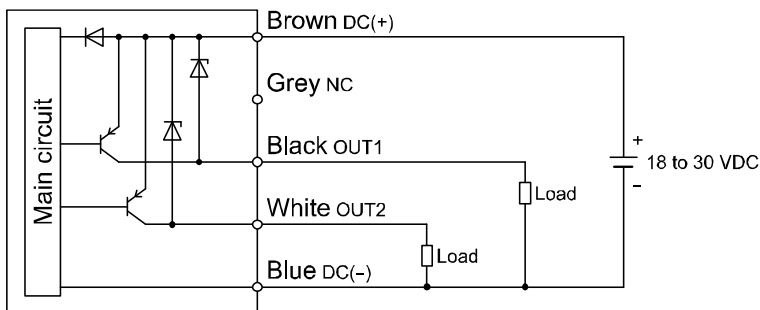

When used as an IO-Link device

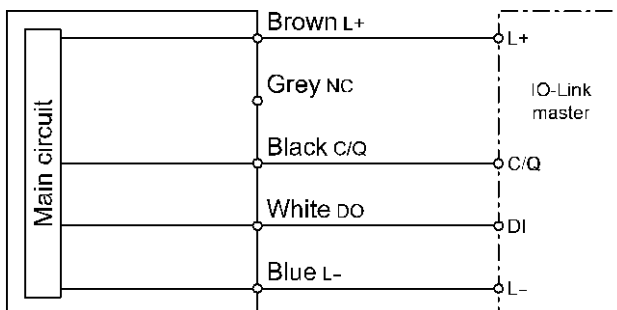

-RT: Switch 2 output + analogue voltage output  
NPN setting

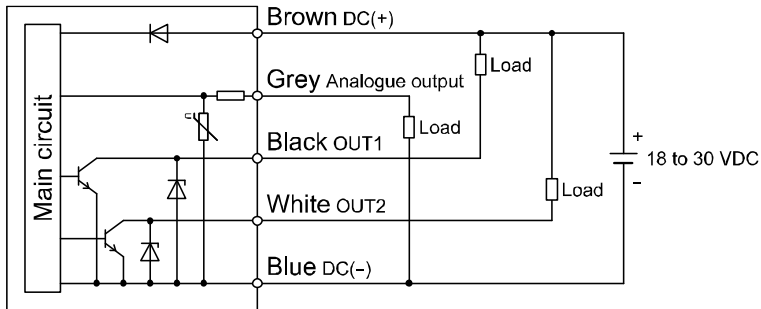

PNP setting

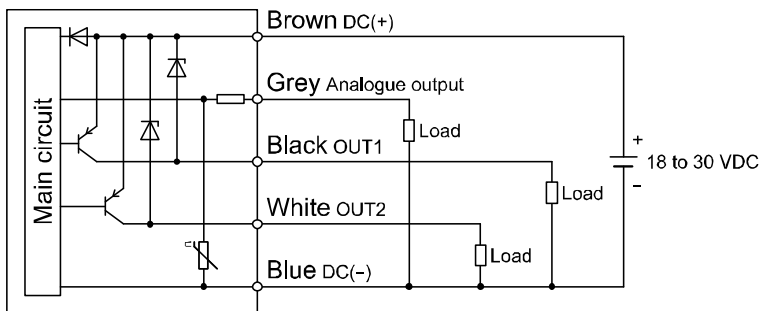



# Outline of Settings [Measurement mode]

## Supply power



The product code is displayed for approximately 3 seconds after supplying power.  
 \*: The switch operation starts within approximately 0.3 seconds after power is supplied.



## [Measurement mode]

Detects the relative humidity and temperature after power is supplied, and indicates the display and switch operation status.  
 This is the basic operation mode. From this mode, move to other modes for setting changes and other function settings.

### Measurement mode screen

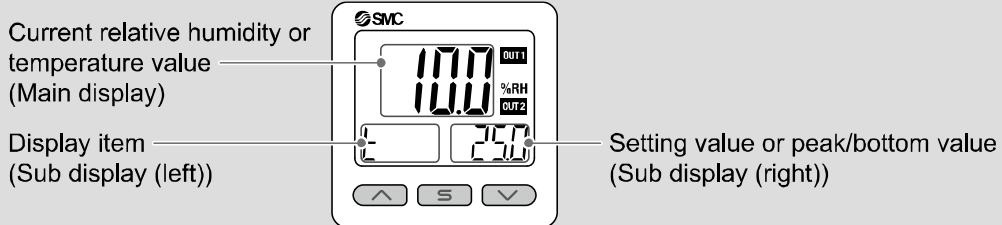

### Content of sub display

In measurement mode, the content of the sub display can be selected by pressing the UP or DOWN button.

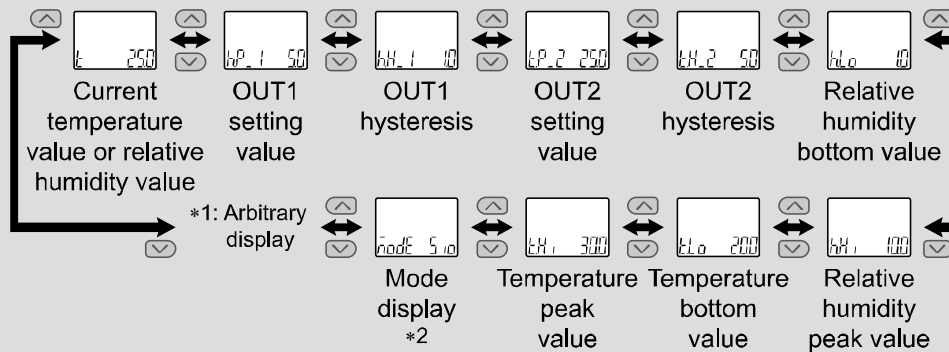

- \*1: An arbitrary display mode can be added to the sub display by setting the [F10] display.  
 If the sub display is switched during the arbitrary display setting, the display will be returned to the arbitrary display 30 seconds later.  
 (The default setting does not include an arbitrary display.)
- \*2: Output specification: Only displayed for L2 (IO-Link + 1 output).

Press the SET button once

Press the SET button for at least 1 second but no more than 3 seconds

Press the SET button for at least 3 seconds but no more than 5 seconds



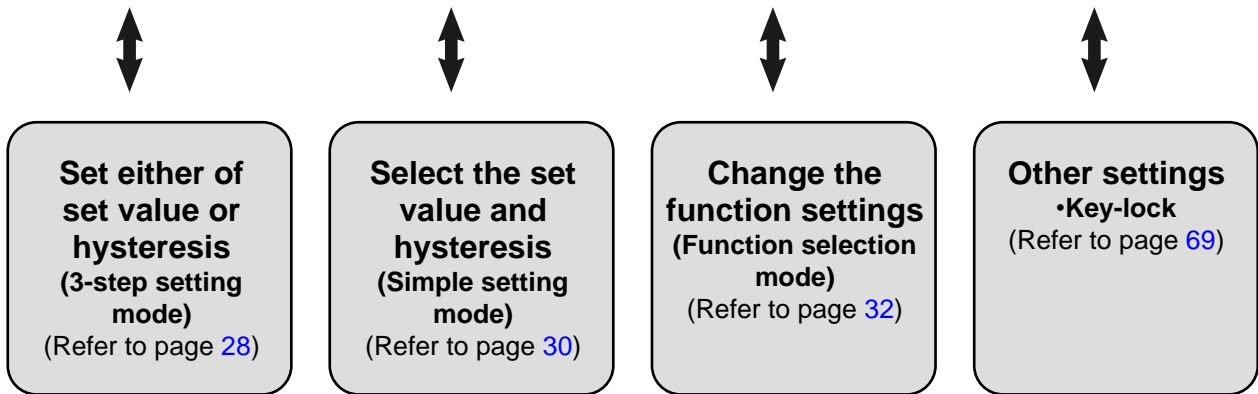

\*: Output continues during setting

\*: If a button operation is not performed for 3 seconds during setting, the display will flash. (This is to prevent the setting from remaining incomplete if, for instance, an operator were to leave during setting).

\*: 3-step setting mode, Simple setting mode, and Function selection mode settings are reflected in each other.

## Setting Relative Humidity and Temperature

### Default settings

When the relative humidity and temperature exceed the set value, the switch will turn on.

When the relative humidity and temperature fall below the set value by the amount of hysteresis or more, the switch will turn off.

\*: Relative humidity is measured at atmospheric pressure.

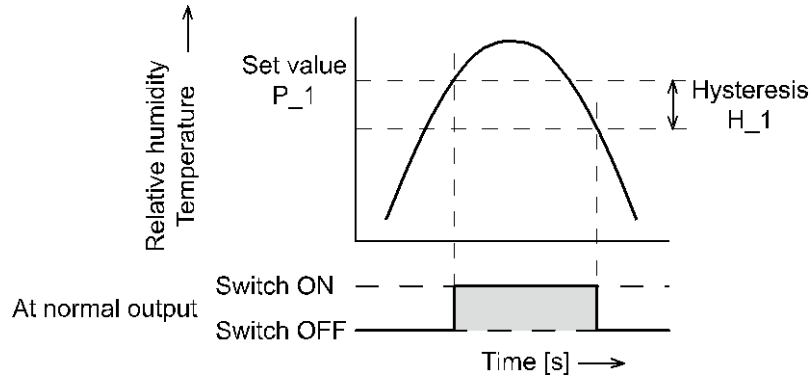

Item	Default settings
OUT1 output operating mode	Relative humidity
[h.P_1] OUT1 setting value	5.0% R.H.
[h.H_1] OUT1 hysteresis	1.0% R.H.

Item	Default settings
OUT2 output operating mode	Temperature
[t.P_2] OUT2 setting value	25.0 °C
[t.H_2] OUT2 hysteresis	5.0 °C

## 3-Step Setting Mode

### 3-step setting mode

In this mode, the setting values can be input in just 3 steps.

Use this mode if the product is to be used straight away after changing only the set values.

(The current relative humidity or temperature value is displayed on the main display).

3-step setting mode is not available from the display when displaying the measurement value.

(When using the 3-step setting mode, select each set value to be displayed by pressing the UP or DOWN button).

### <Operation>

"3-step setting mode (Hysteresis mode)"

In 3-step setting mode, the relative humidity or temperature set value (h.P\_1 (t.P\_1) or h.n\_1 (t.n\_1), h.P\_2 (t.P\_2) or h.n\_2 (t.n\_2)) and hysteresis (h.H\_1 (t.H\_1) or h.H\_2 (t.H\_2)) can be changed.

Set the items on the sub display (set value or hysteresis) with the UP or DOWN buttons in advance.

When changing the set value, follow the operation below. The hysteresis setting can be changed in the same way.

- (1) Press the SET button once when the item to be changed is displayed on the sub display.  
The set value on the sub display (right) will start flashing.

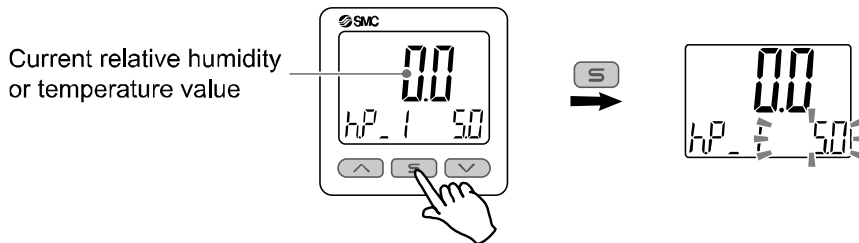

- (2) Press the UP or DOWN button to change the set value.  
The set value can be increased using the UP button and can be reduced using the DOWN button.

- Press the UP button once to increase the value by one digit or press and hold to continuously increase.

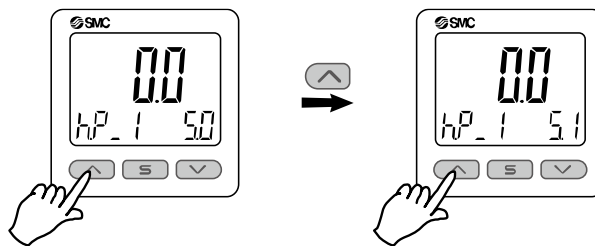

- Press the DOWN button once to reduce the value by one digit or press and hold to continuously reduce.

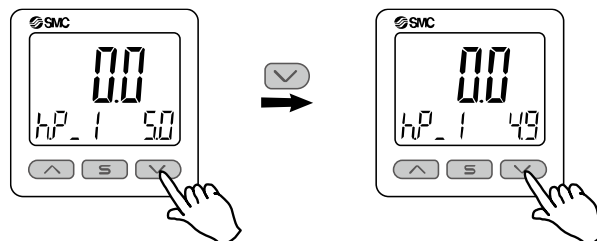

- (3) Press the SET button to complete the setting.

In the window comparator mode, the switch operates within the relative humidity or temperature setting range (between h.P1L or t.P1L and h.P1H or t.P1H).

Set h.P1L or t.P1L (lower limit of the switch operation point), h.P1H or t.P1H (upper limit of the switch operation point), or h.H1 or t.H1 (hysteresis) following the instructions given in page 28.

(When reversed output is selected, it will be h.n1L or t.n1L and h.n1H or t.n1H).

Refer to "List of output modes" on page 38 for the relationship between the set value and switch operation.

\*: OUT2 can also be set following the same instructions.

Setting of the normal/reversed output switching and hysteresis/window comparator mode switching are performed using the function selection mode [F 1] OUT1 setting or [F 2] OUT2 setting.

## Simple Setting Mode

### <Operation>

Simple setting mode (Hysteresis mode)

The simple setting mode allows the set value and hysteresis to be changed while viewing the current relative humidity or temperature value on the main display.

- (1) Press the SET button for between 1 and 3 seconds in measurement mode. [SEt] is displayed on the main display.

When the button is released while in the [SEt] display, the current measurement value is displayed on the main display, [h.P\_1 or t.P\_1] or [h.n\_1 or t.n\_1] is displayed on the sub display (left), and the set value (flashing) is displayed on the sub display (right).

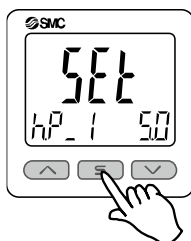

- (2) Change the set value using the UP or DOWN button, and press the SET button to set the value. Then, the setting moves to hysteresis setting.

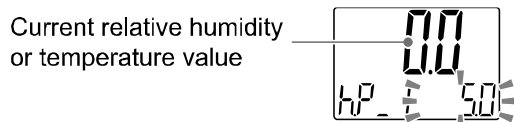

- (3) Change the set value using the UP or DOWN button, and press the SET button to set the value.



- (4) Press and hold the SET button for 2 seconds or longer to complete setting.  
(If the button is pressed for less than 2 seconds, the setting will return to the setting of OUT2).

\*1: Selected items (1) to (4) become valid after pressing the SET button.

\*2: After enabling a setting by pressing the SET button, it is possible to return to measurement mode in any item of (1) to (4) by pressing the SET button for 2 seconds or longer.

\*3: When the output mode is set to error output or output OFF (Refer to page 35), the simple setting mode cannot be used.  
(The setting changes to measurement mode by releasing the button when [SEt] is displayed).

\*4: When OUT2 set items are displayed on the sub display in measurement mode, step (1) will begin with the OUT2 setting [P\_2] or [n\_2].

For the window comparator mode, set h.P1L or t.P1L (lower limit of the switch operation point), h.P1H or t.P1H (upper limit of the switch operation point), or h.H1 or t.H1 (hysteresis) following the instructions given in page 30.

(When reversed output is selected, it will be h.n1L or t.n1L and h.n1H or t.n1H).

Refer to "List of output modes" on page 38 for the relationship between the set value and operation.

\*: OUT2 can also be set following the same instructions.

## Function Selection Mode

### ■ Function selection mode

In measurement mode, press the SET button for between 3 and 5 seconds to display [F 0].

The mode in which [F□□] is displayed and respective function settings can be changed, is referred to as function selection mode.

In function selection mode, press the SET button for 2 seconds or longer to return to measurement mode.

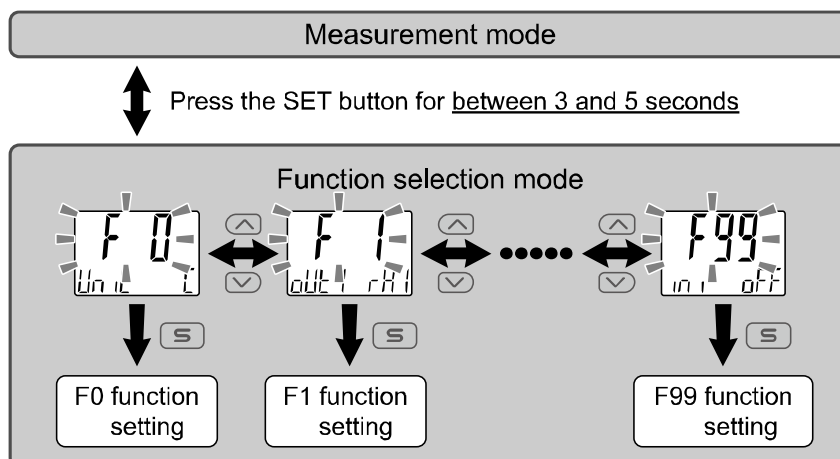

\*: Some functions are not supported on models with specific product numbers. [- -] will be displayed on the sub display (right) for functions that are not supported or cannot be selected due to other settings.

### ■ Default setting

The default settings are as follows.

If these settings are acceptable, use them without changing the setting.

To change the setting, enter function selection mode.

●[F 0] System setting ➡ Page 34

Item	Description	Default setting
Display units	When the units specification is "Nil," either Celsius: °C or Fahrenheit: °F can be selected.	°C
Switch output specification	Either PNP or NPN can be selected.	PnP
IO-Link enabled/disabled	When the output specification is IO-Link compatible, enable or disable of IO-Link can be selected.	ON (Enabled)



•[F 1] OUT1 setting ➡ Page 35

Item	Description	Default setting
Output operating mode	Relative humidity, temperature, error output, or output OFF can be selected.	Relative humidity
Output mode	Either hysteresis mode or window comparator mode can be selected.	Hysteresis mode
Reversed output	Normal or reversed switch output mode can be selected.	Normal output
Relative humidity/temperature setting	Switch output ON point or OFF point can be set.	5.0% R.H.
Hysteresis	Setting of the hysteresis will prevent the switch output from chattering.	1.0% R.H.
Display colour	Display colour can be selected linked to the output.	OUT1 ON: Red OUT1 OFF: White

•[F 2] OUT2 setting ➡ Page 39

Item	Description	Default setting
Output operating mode	Relative humidity, temperature, error output, or output OFF can be selected.	Temperature
Output mode	Either hysteresis mode or window comparator mode can be selected.	Hysteresis mode
Reversed output	Normal or reversed switch output mode can be selected.	Normal output
Relative humidity/temperature setting	Switch output ON point or OFF point can be set.	25.0 °C
Hysteresis	Setting of the hysteresis will prevent the switch output from chattering.	5.0 °C
Display colour	Display colour can be selected linked to the output.	OUT1 ON: Red OUT1 OFF: White

•Other setting

Item	Page	Default setting
[F 3] Digital filter setting	Page 42	0.00 s
[F 6] Display value fine adjustment setting	Page 43	0.0%
[F10] Display setting	Page 44	Main display: Relative humidity Sub display: std (Standard)
[F11] Display resolution setting	Page 51	1,000-division (Relative humidity) 500-division (Temperature)
[F22] Analogue output setting	Page 52	Relative humidity
[F50] Relative humidity OUT1 setting	Page 53	*
[F51] Relative humidity OUT2 setting	Page 54	*
[F52] Temperature OUT1 setting	Page 55	*
[F53] Temperature OUT2 setting	Page 56	*
[F80] Display off mode setting	Page 57	ON (display on)
[F81] Security code input setting	Page 58	OFF
[F90] Setting of all functions	Page 60	OFF
[F96] Cycle time check	Page 62	*
[F98] Output check	Page 63	N/A (Normal output)
[F99] Reset to default setting	Page 68	OFF

\*: Available only when IO-Link function is enabled.

## ■ [F 0] System setting

The display units selection is only available for models with the units selection function.

### <Operation>

Press the UP or DOWN button in function selection mode to display [F 0].

Press the SET button. ↓ Move on to the selection of display unit.

#### Selection of display unit

Press the UP or DOWN button to change the display units.  
 \*: Only °C unit is available for models without the units selection function.

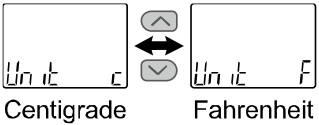

Centigrade      Fahrenheit

• Available display unit and minimum set value

Unit	
°C	0.1
°F	1



Press the SET button to save the setting. ↓ Move to switch output NPN/PNP specification settings.

#### Setting of switch output PNP/NPN specifications

The switch output of this product can be selected between PNP and NPN output depending on the device configuration.  
 Press the UP or DOWN button to select the switch output specification.

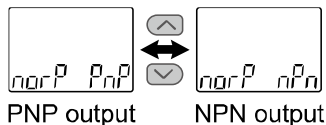

PNP output      NPN output

For IO-Link compatible product  
 Press the SET button to save the setting.

↓ Move to IO-Link enabled/disabled setting.

For products not compatible with IO-Link  
 Press the SET button to save the setting.

Return to function selection mode.

#### IO-Link enabled/disabled setting

IO-Link enabled/disabled can be set.

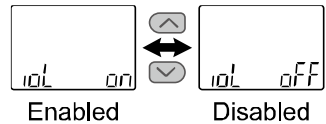

Enabled      Disabled

\*: Set to disabled when not used with IO-Link mode.  
 \*: When changed from disabled to enabled while the switch output is on, the approx. 1 ms switch output will turn off.

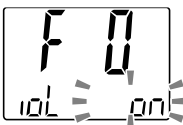

Press the SET button to save the setting.

↓ Return to function selection mode.

[F 0] System setting completed

## ■ [F 1] OUT1 setting

Set the output mode of OUT1.

Output turns on when the relative humidity and temperature are greater than the set value.

The display colour changes according to the OUT1 output status. It will turn red when the output is ON and turn white when the output is OFF.

Refer to "List of output modes" on page 38 for details of operations associated with the setting items.

### <Operation>

Press the UP or DOWN button in function selection mode to display [F 1].

Press the SET button. ↓ Move to output operating mode setting.

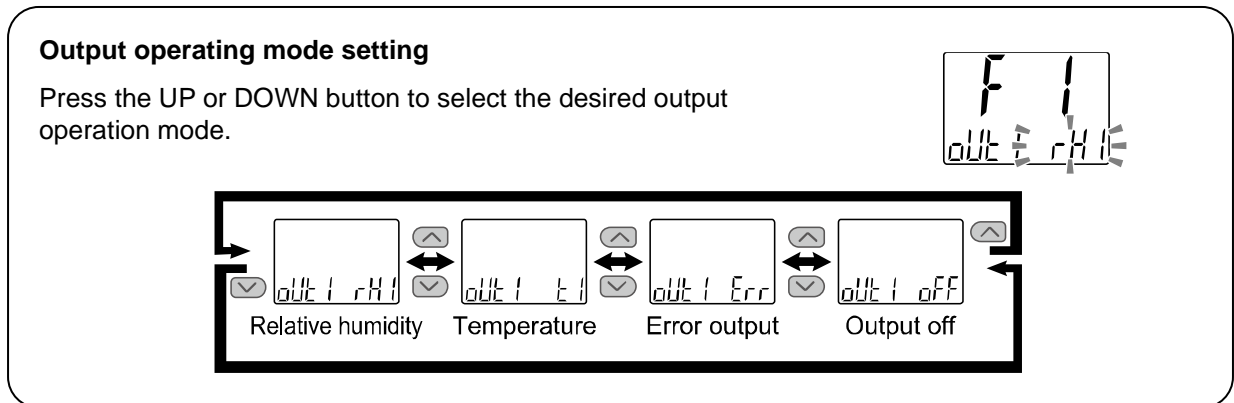

When [rH1] relative humidity or [t1] temperature is selected  
Press the SET button to save the setting.

Move to output mode setting.

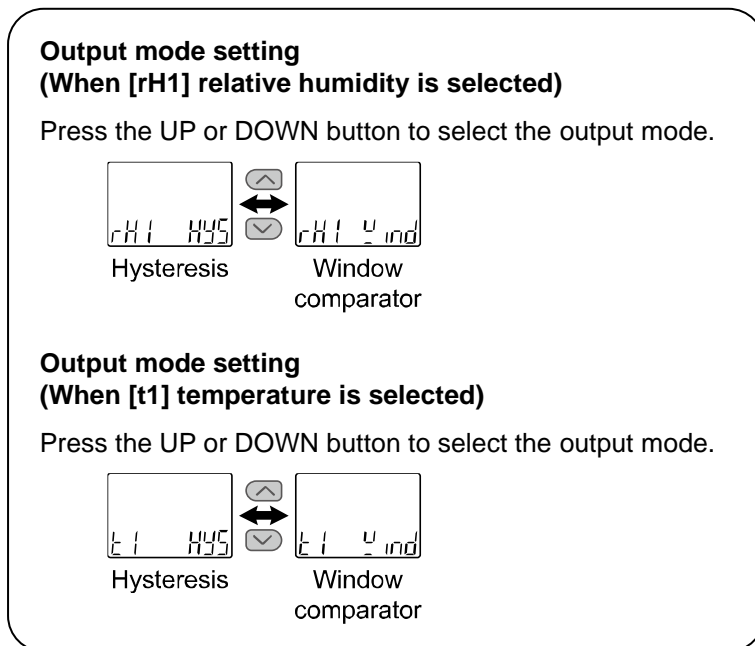

Press the SET button to save the setting.

Move to reverse output setting.

When [oFF] output off is selected  
Press the SET button to save the setting.

Move to display colour setting.

When [Err] error output is selected  
Press the SET button to save the setting.

Move to reverse output setting.

### Reversed output setting

Press the UP or DOWN button to select reversed output.

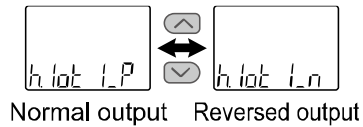

For relative humidity: [h.1ot]  
For temperature: [t.1ot]  
For error output: [E.1ot]

Press the SET button to save the setting. → Move to relative humidity or temperature setting.

### Relative humidity or temperature setting

Set the relative humidity or temperature setting based on the setting method on page 28.



For hysteresis mode: [h.P\_1 or t.P\_1]  
For window comparator mode: [h.P1L or t.P1L]  
                                                          [h.P1H or t.P1H]  
When reversed output is selected, "P" changes to "n" as  
[h.P\_1 or t.P\_1] → [h.n\_1 or t.n\_1].

When [Err] error output is selected

Press the SET button to save the setting.

Press the SET button to save the setting. → Move to hysteresis setting.

Move to reverse output setting.

### Hysteresis setting

Set the hysteresis based on the setting method on page 28.

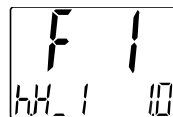

For hysteresis mode: [h.H\_1 or t.H\_1]  
For window comparator mode: [h.H1 or t.H1]

Press the SET button to save the setting. → Move to display colour setting.

### Display colour setting

Press the UP or DOWN button to select a display colour.

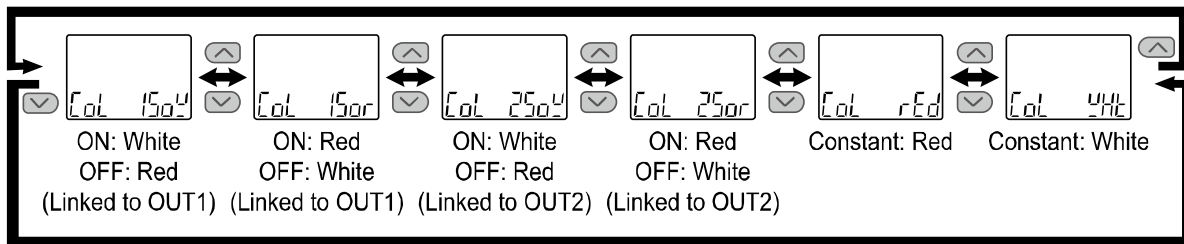

Press the SET button to save the setting. ↓ Return to function selection mode.

[F 1] OUT1 setting completed

\*1: A selected item is enabled after the SET button is pressed.

\*2: After enabling a setting by pressing the SET button, it is possible to return to measurement mode by pressing the SET button for 2 seconds or longer.

•List of output modes

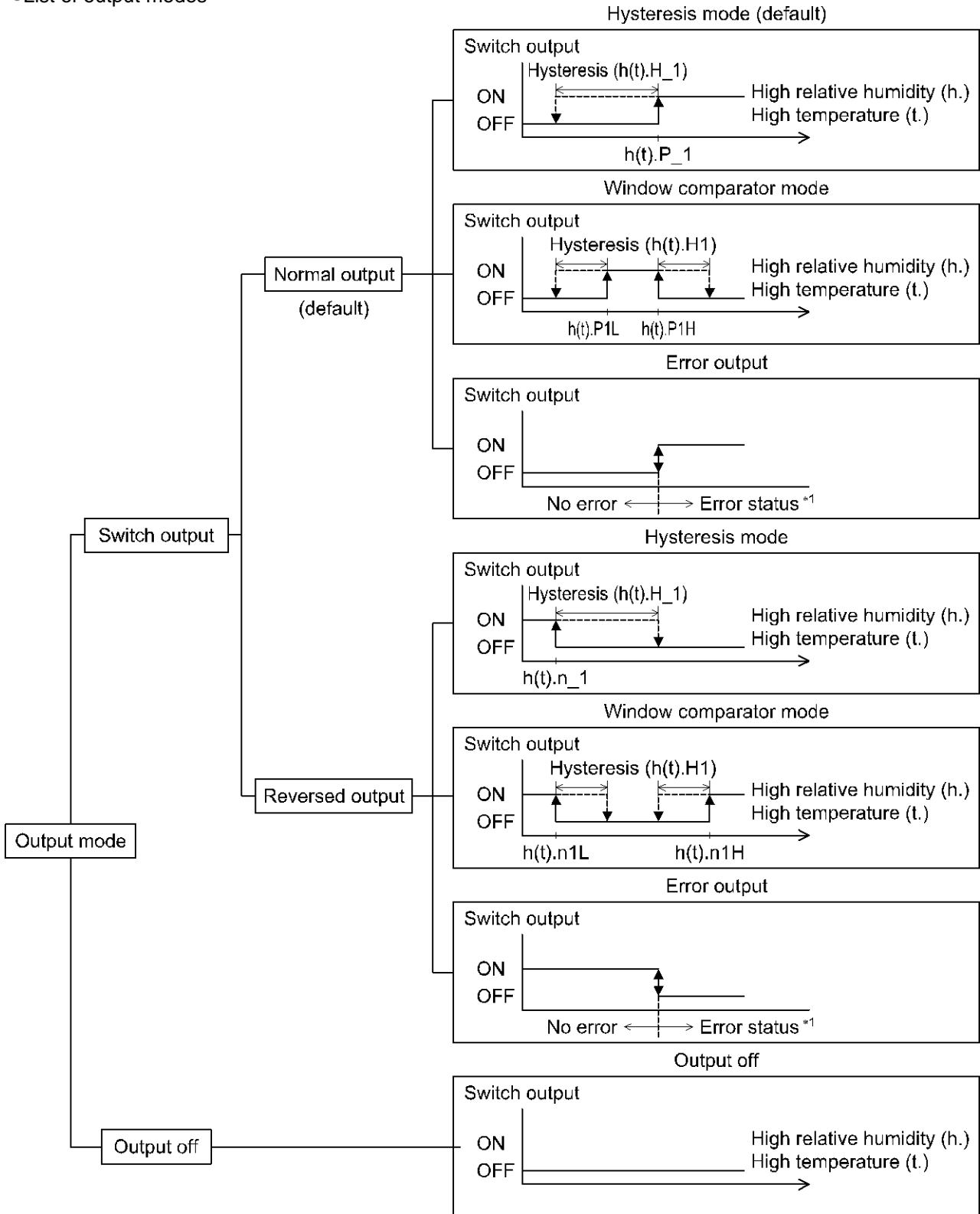

\*1: Applicable errors are Er 1, 2, 5, 6, 8, and 9 (excluding the error output).

\*: The figure above shows the operation of OUT 1. For OUT2, all "1" in the above figure will be changed to "2." (Example)  $P_1 \rightarrow P_2$

If the point at which the switch output changes is outside of the setting range due to the selection of normal or reversed output, the hysteresis value is automatically adjusted.

## ■[F 2] OUT2 setting

Set the output mode of OUT2.

Output turns on when the relative humidity and temperature are greater than the set value.

Refer to "List of output modes" on page 38 for details of operations associated with the setting items.

### <Operation>

Press the UP or DOWN button in function selection mode to display [F 2].

Press the SET button. ↓ Move to output operating mode setting.

**Output operating mode setting**

Press the UP or DOWN button to select the desired output operation mode.

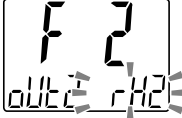

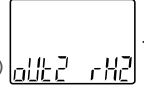

  
 Relative humidity



  
 Temperature



  
 Error output



  
 Output off

When [rH2] relative humidity or [t2] temperature is selected  
Press the SET button to save the setting.

Move to output mode setting.

**Output mode setting**  
(When [rH2] relative humidity is selected)

Press the UP or DOWN button to select the output mode.

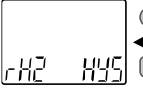
  
 Hysteresis

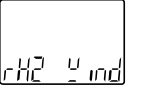

  
 Window comparator

**Output mode setting**  
(When [t2] temperature is selected)

Press the UP or DOWN button to select the output mode.

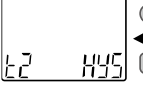
  
 Hysteresis

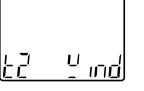

  
 Window comparator

Press the SET button to save the setting.

Move to reverse output setting.

When [off] output off is selected  
Press the SET button to save the setting.

Move to display colour setting.

When [Err] error output is selected  
Press the SET button to save the setting.

Move to reverse output setting.

-39-  

No. DOC1060358

### Reversed output setting

Press the UP or DOWN button to select reversed output.

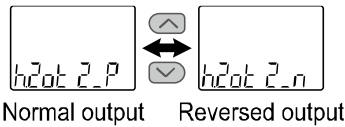

For relative humidity: [h.2ot]  
For temperature: [t.2ot]  
For error output: [E.2ot]

Press the SET button to save the setting. Move to relative humidity or temperature setting.

### Relative humidity or temperature setting

Set the relative humidity or temperature setting based on the setting method on page 28.



For hysteresis mode: [h.P\_2 or t.P\_2]  
For window comparator mode: [h.P2L or t.P2L]  
[h.P2H or t.P2H]  
When reversed output is selected, "P" changes to "n" as [h.P\_2 or t.P\_2] → [h.n\_2 or t.n\_2].

Press the SET button to save the setting. Move to hysteresis setting.

### Hysteresis setting

Set the hysteresis based on the setting method on page 28.



For hysteresis mode: [H\_2 or t.H\_2]  
For window comparator mode: [h.H2 or t.H2]

Press the SET button to save the setting. Move to display colour setting.

When [Err] error output is selected

Press the SET button to save the setting.

Move to reverse output setting.



### Display colour setting

Press the UP or DOWN button to select a display colour.

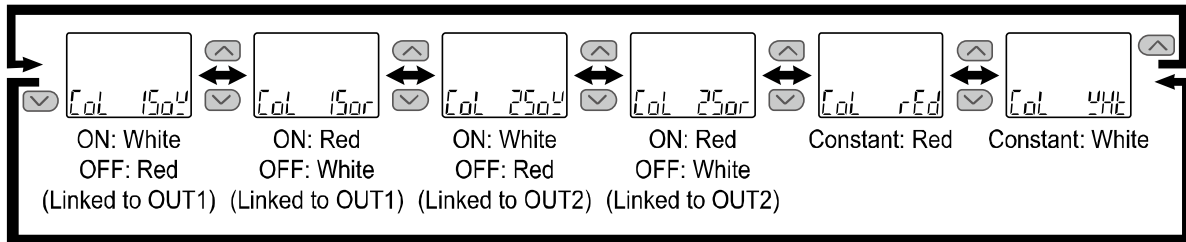

Press the SET button to save the setting. ↓ Return to function selection mode.

[F 2] OUT2 setting completed

\*1: A selected item is enabled after the SET button is pressed.

\*2: After enabling a setting by pressing the SET button, it is possible to return to measurement mode by pressing the SET button for 2 seconds or longer.

## ■[F 3] Digital filter setting

The digital filter can be selected to filter the relative humidity and temperature displayed value. Output chattering or display flicker in measurement mode can be reduced by setting the digital filter. Digital filter can be set in 0.01 sec. increment in the range of 0.00 to 60.00 sec.

### <Operation>

Press the UP or DOWN button in function selection mode to display [F 3].

Press the SET button. ↓ Move to digital filter setting.

#### Digital filter setting

Press the UP or DOWN button to change the digital filter setting.



Press the SET button to save the setting. ↓ Return to function selection mode.

[F 3] Digital filter setting completed

\*1: Each set value is a guideline for 90% response time.

\*2: Switch output and analogue output are affected.

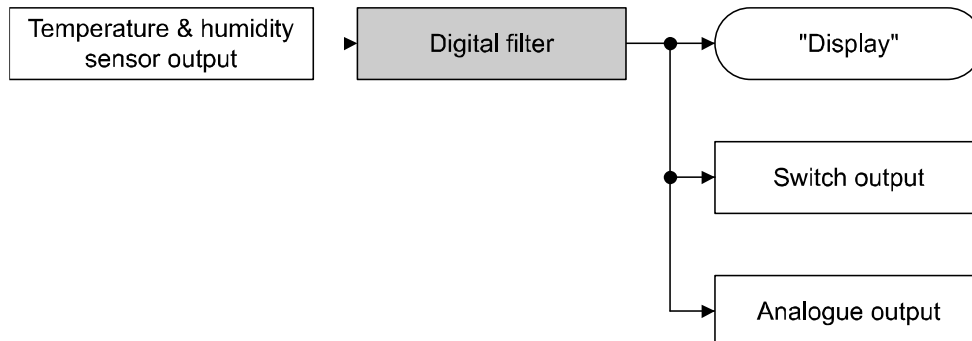

## ■[F 6] Display value fine adjustment setting

This function is to manually perform a fine adjustment of the displayed relative humidity and temperature values.

It can be adjusted in the range of  $\pm 5\%$  R.D. ( $\pm 5\%$  F.S. for temperature).

### <Operation>

Press the UP or DOWN button in function selection mode to display [F 6].

Press the SET button. ↓ Move to display value fine adjustment setting (relative humidity).

#### Display value fine adjustment setting (relative humidity)

Press the UP or DOWN button to change the adjustment rate.

When the adjustment rate is changed, the relative humidity value after the adjustment will be displayed on the main display.

Relative humidity value after adjustment



Press the SET button to save the setting. ↓ Move to display value fine adjustment setting (temperature).

#### Display value fine adjustment setting (temperature)

Press the UP or DOWN button to change the adjustment rate.

When the adjustment rate is changed, the temperature value after the adjustment will be displayed on the main display.

Temperature value after adjustment



Press the SET button to save the setting. ↓ Return to function selection mode.

[F 6] Display value fine adjustment setting completed

## ■[F10] Display setting

This function allows for changing the display method of the main display and sub display. Details of display contents are provided on page 46.

### <Operation>

Press the UP or DOWN button in function selection mode to display [F10].

Press the SET button. ↓ Move to main display setting.

**Main display setting**

Press the UP or DOWN button to select the display value of the main display.

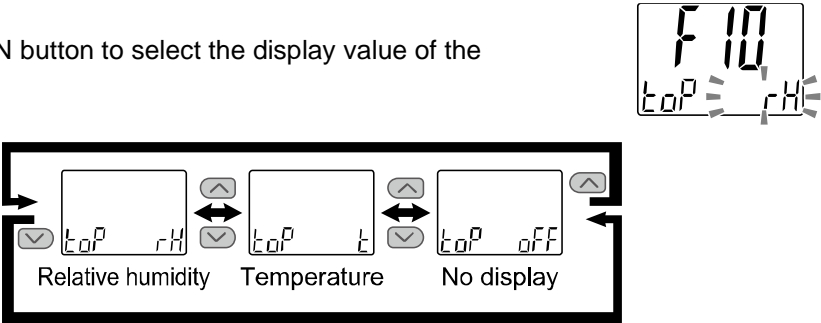

Relative humidity    Temperature    No display

Press the SET button to save the setting. ↓ Move to sub display setting.



### Sub display setting

Press the UP or DOWN button to select the display method of the sub display.

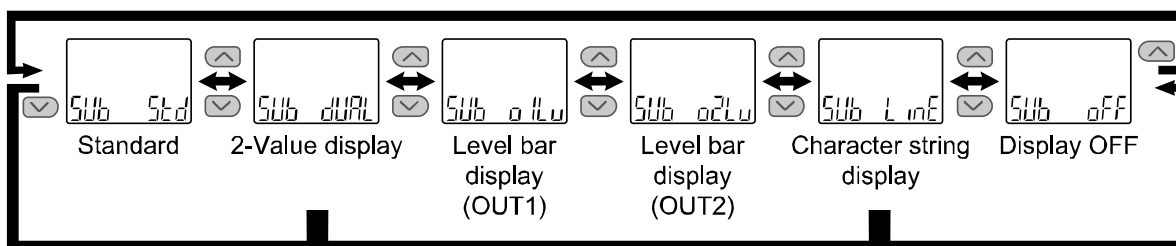

[dUAL] 2-value display is selected  
Press the SET button to save the setting.

Move to sub display (left) display item setting.

When [LinE] character string display is selected  
Press the SET button to save the setting.

Move to line name input setting.

### Sub display (left) setting

Set the sub display (left) from the selection list on page 47.

Press the SET button to save the setting. Move to sub display (right) setting.

### Sub display (right) setting

Set the sub display (right) from the selection list on page 47.

Press the SET button to save the setting. Return to function selection mode.

### Line name input setting

Press the UP or DOWN button to input a line name to display on the sub display (right).   
Press the SET button to make the next digit to the right flash and then continue to input a line name.  
(If the SET button is pressed at the last digit, the cursor returns to the first digit and the first digit starts flashing).

Characters are displayed in this order: A -> b -> ... -> Y -> (Z) -> 0 -> 1 -> ... -> 9 -> symbols -> space.  
Press and hold the UP or DOWN buttons to simultaneously add/delete a dot (decimal point).

Press and hold the SET button for 1 second or longer to make the entire set line name flash.  
(At this point, the setting of the line name is not complete).

Press the SET button to save the setting. Return to function selection mode.

When [dUAL] 2-value display [LinE] character string display is not selected  
Press the SET button to save the setting.

Return to function selection mode.

[F10] Display setting completed

## <Sub display indication>

### •Standard

The standard display function displays items and values on the sub display.

The displayed item varies depending on the setting of the output mode. Select the displayed items by pressing the UP or DOWN button in measurement mode.

For display items of the current temperature value or relative humidity value, this is linked to the settings on the main display.

When "Relative humidity" or "No display" is selected for the settings on the main display, the temperature value is displayed; when "Temperature" is selected, the relative humidity value is displayed.

(Hysteresis mode, error output, switch output off)

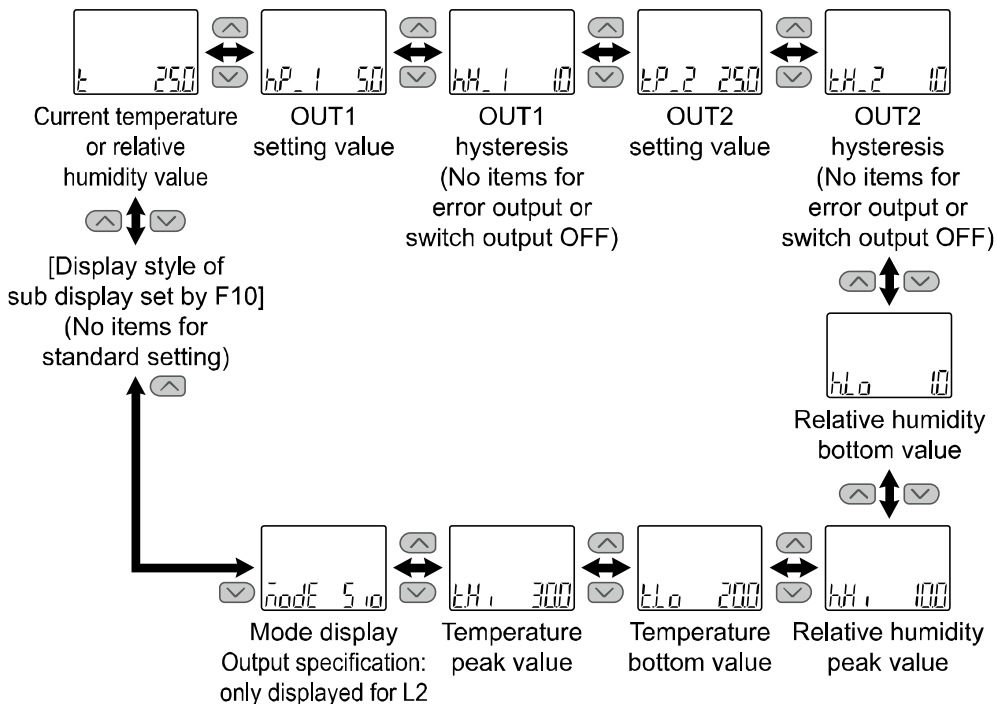

(Window comparator mode)

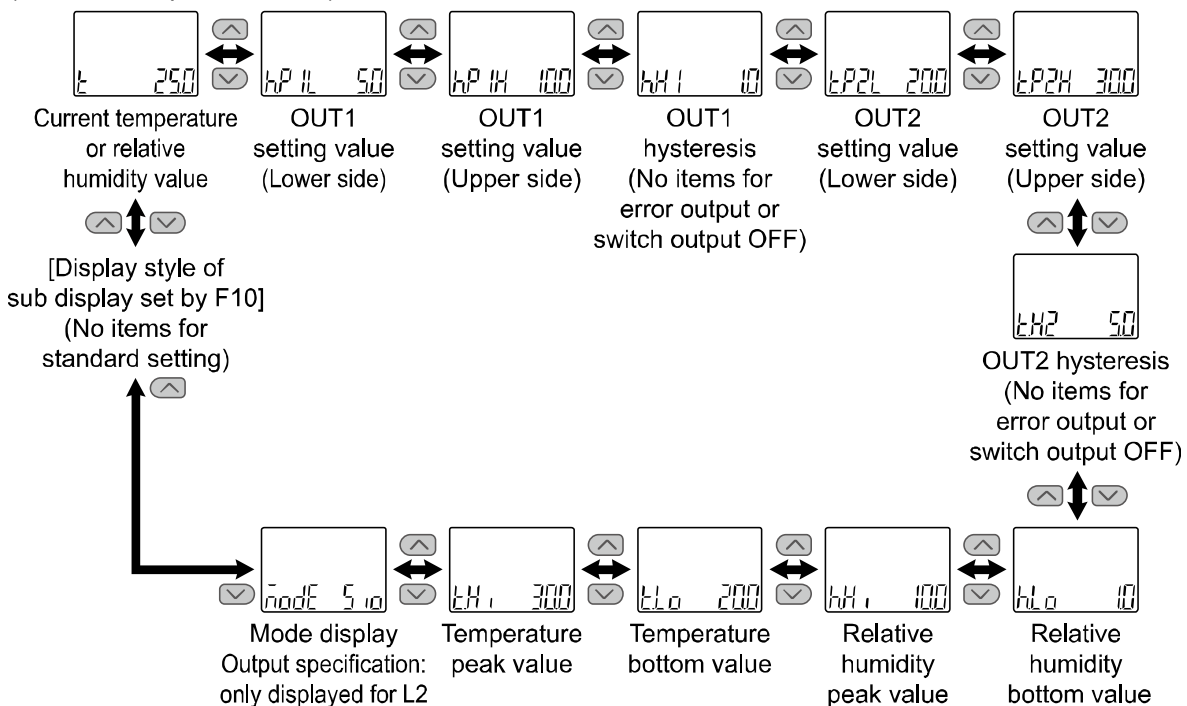

**•2-value display**

The 2-value display function displays the items listed below on the right and left side of the sub display.

List of items for selection

Display item	Details	Sub display indication selection		Remarks
		Left side	Right side	
rH	Relative humidity value	<input type="radio"/>	<input type="radio"/>	
t	Temperature value	<input type="radio"/>	<input type="radio"/>	
hP_1 (h <sub>n_1</sub> )	Relative humidity OUT1 hysteresis mode set value	<input type="radio"/>	<input type="radio"/>	When relative humidity or hysteresis mode is selected
hH_1	Relative humidity OUT1 hysteresis mode hysteresis	<input type="radio"/>	<input type="radio"/>	When relative humidity or hysteresis mode is selected
hP_1L (h <sub>n_1L</sub> )	Relative humidity OUT1 window comparator mode set value (Lower side)	<input type="radio"/>	<input type="radio"/>	When relative humidity or window comparator mode is selected
hP_1H (h <sub>n_1H</sub> )	Relative humidity OUT1 window comparator mode set value (Upper side)	<input type="radio"/>	<input type="radio"/>	When relative humidity or window comparator mode is selected
hH_1	Relative humidity OUT1 window comparator mode hysteresis	<input type="radio"/>	<input type="radio"/>	When relative humidity or window comparator mode is selected
hP_2 (h <sub>n_2</sub> )	Relative humidity OUT2 hysteresis mode set value	<input type="radio"/>	<input type="radio"/>	When relative humidity or hysteresis mode is selected
hH_2	Relative humidity OUT2 hysteresis mode hysteresis	<input type="radio"/>	<input type="radio"/>	When relative humidity or hysteresis mode is selected
hP_2L (h <sub>n_2L</sub> )	Relative humidity OUT2 window comparator mode set value (Lower side)	<input type="radio"/>	<input type="radio"/>	When relative humidity or window comparator mode is selected
hP_2H (h <sub>n_2H</sub> )	Relative humidity OUT2 window comparator mode set value (Upper side)	<input type="radio"/>	<input type="radio"/>	When relative humidity or window comparator mode is selected
hH_2	Relative humidity OUT2 window comparator mode hysteresis	<input type="radio"/>	<input type="radio"/>	When relative humidity or window comparator mode is selected
tP_1 (t <sub>n_1</sub> )	Temperature OUT1 hysteresis mode set value	<input type="radio"/>	<input type="radio"/>	When temperature or hysteresis mode is selected
tH_1	Temperature OUT1 hysteresis mode hysteresis	<input type="radio"/>	<input type="radio"/>	When temperature or hysteresis mode is selected
tP_1L (t <sub>n_1L</sub> )	Temperature OUT1 window comparator mode set value (Lower side)	<input type="radio"/>	<input type="radio"/>	When temperature or window comparator mode is selected
tP_1H (t <sub>n_1H</sub> )	Temperature OUT1 window comparator mode set value (Upper side)	<input type="radio"/>	<input type="radio"/>	When temperature or window comparator mode is selected
tH_1	Temperature OUT1 window comparator mode hysteresis	<input type="radio"/>	<input type="radio"/>	When temperature or window comparator mode is selected
tP_2 (t <sub>n_2</sub> )	Temperature OUT2 hysteresis mode set value	<input type="radio"/>	<input type="radio"/>	When temperature or hysteresis mode is selected
tH_2	Temperature OUT2 hysteresis mode hysteresis	<input type="radio"/>	<input type="radio"/>	When temperature or hysteresis mode is selected
tP_2L (t <sub>n_2L</sub> )	Temperature OUT2 window comparator mode set value (Lower side)	<input type="radio"/>	<input type="radio"/>	When temperature or window comparator mode is selected
tP_2H (t <sub>n_2H</sub> )	Temperature OUT2 window comparator mode set value (Upper side)	<input type="radio"/>	<input type="radio"/>	When temperature or window comparator mode is selected
tH_2	Temperature OUT2 window comparator mode hysteresis	<input type="radio"/>	<input type="radio"/>	When temperature or window comparator mode is selected

Display item	Details	Sub display		Remarks
		Left side	Right side	
hH <sub>1</sub>	Relative humidity peak value	○	○	
hLo	Relative humidity bottom value	○	○	
tH <sub>1</sub>	Temperature peak value	○	○	
tLo	Temperature bottom value	○	○	
Unit	Display units	○	○	
md1	OUT1 output mode/output type	○	×	
md2	OUT2 output mode/output type	×	○	
oUt	NPN/PNP output setting	○	○	
LinE	Arbitrary character string	○	○	
oFF	Display OFF	○	○	

It will be shown as the table below when the unit is selected.

Unit	Characters displayed on the sub display
Centigrade	°C
Fahrenheit	°F

Table showing the output mode and output type when Md1 or Md2 is selected.

Output mode	Output type	Display type
Hysteresis mode	Normal	
	Reversed	
Window comparator mode	Normal	
	Reversed	
Error output	Normal/Reversed	
Switch output off	-	

The 3-step setting mode is not available when set to the 2-value display.

(When using the 3-step setting mode, select each set value to be displayed by pressing the UP or DOWN button).

When the output operation mode is changed after selecting the 2-value display, the selected display items will not be applicable and [- -] will be displayed. In this case, select items for the 2-value display setting again.



•Level bar display

The level bar display is a function used to visualize the relative humidity/temperature values and the ON area for the switch output on the sub display.

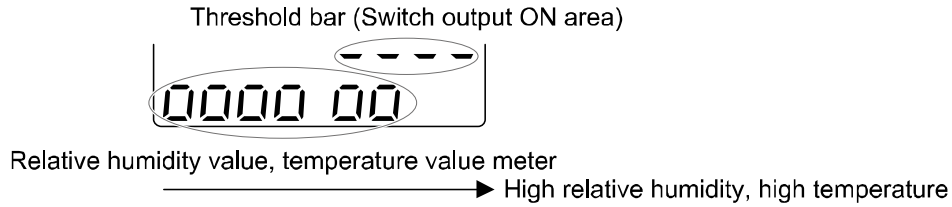

The display type varies depending on the setting of the output mode.

(For hysteresis mode and window comparator mode).

The threshold bar displaying the switch output ON area is displayed according to the table below using the output mode.

(When error output or output is off).

The threshold value bar and level bar will not be displayed.

Output mode	Output type	Threshold value bar display type
Hysteresis mode	Normal	 h(t).P_1
	Reversed	 h(t).n_1
Window comparator mode	Normal	 h(t).P1L    h(t).P1H
	Reversed	 h(t).n1L    h(t).n1H
Error output	Normal/Reversed	No indication
Switch output off	-	No indication

The level bar display resolution (relative humidity/temperature for one "O") varies depending on the output mode.

Output mode	Display resolution	
	OUT1	OUT2
Hysteresis mode	1/10 of h.P_1 or t.P_1 (h.n_1 or t.n_1) However, the minimum resolution is 1% R.H.	1/10 of h.P_2 or t.P_2 (h.n_2 or t.n_2) However, the minimum resolution is 1% R.H.
Window comparator mode	1/4 of h.P1H or t.P1H-h.P1L or t.P1L (h.n1H or t.n1H-h.n1L or t.n1L)	1/4 of h.P2H or t.P2H-h.P2L or t.P2L (h.n2H or t.n2H-h.n2L or t.n2L)
Error output	Level bar will not be displayed.	
Switch output off		

**•Character string display**

Function to display the specified character string on the sub display.

When a line name is entered, displayable characters for each digit are as follows.

The characters Q, X, Z, /, and \* cannot be displayed.

A	B	C	D	E	F	G	H	I	J	K	L	M	N	O	P	R	S	T	U	V	W	Y
A	b	c	d	e	f	G	H	I	J	K	L	M	N	O	P	r	S	T	U	V	W	Y
0	1	2	3	4	5	6	7	8	9	Symbol	Space	(Dot)										
0	1	2	3	4	5	6	7	8	9	_	-	.										

**•Display OFF**

The Sub display is turned off.

## ■[F11] Display resolution setting

This function is to change the displayed digits.  
The flicker of the display can be reduced.

### <Operation>

Press the UP or DOWN button in function selection mode to display [F11].

Press the SET button. ↓ Move to display resolution (relative humidity) setting.

#### Display resolution setting (Relative humidity)

Press the UP or DOWN button to select the display resolution.

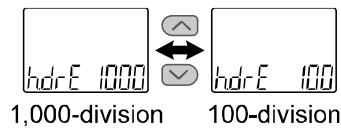

Press the SET button to save the setting. ↓ Move to display resolution (temperature) setting.

#### Display resolution setting (Temperature)

Press the UP or DOWN button to select the display resolution.

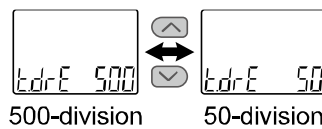

Press the SET button to save the setting. ↓ Return to function selection mode.

[F11] Display resolution setting completed

## ■[F22] Analogue output setting

The analogue output setting can be changed when the product is analogue output compatible.

### <Operation>

Press the UP or DOWN button in function selection mode to display [F22].

Press the SET button. ↓ Move to selection of analogue output object.

#### Selection of analogue output object

Press the UP or DOWN button to select the analogue output object.

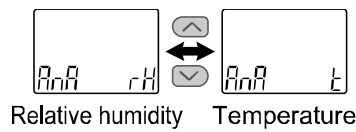

When [AnA rH] relative humidity is selected

Press the SET button to save the setting.

Move to enter the relative humidity analogue free span setting value.

When [AnA t] temperature is selected

Press the SET button to save the setting.

Move to enter the temperature analogue free span setting value.

#### Enter relative humidity analogue free span setting value

Press the UP or DOWN button to set the analogue span point (5 V) within the range of 10 to 100% R.H. of the relative humidity 100% R.H.

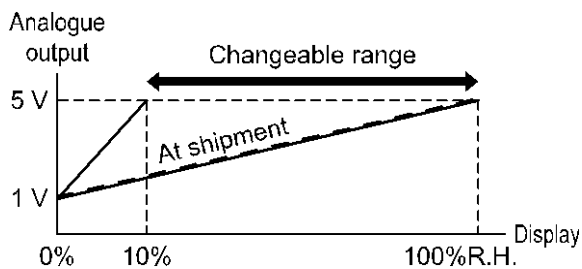

#### Enter temperature analogue free span setting value

Press the UP or DOWN button to set the analogue span point (5 V) within 5 to 55 °C.

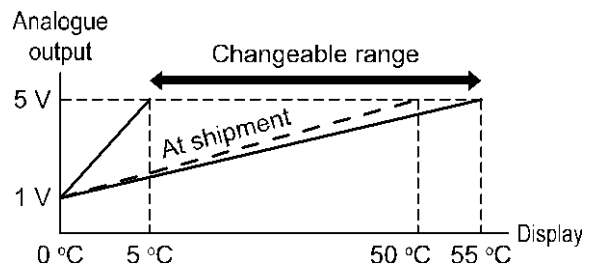

Press the SET button to save the setting. ↓ Return to function selection mode.

[F22] Analogue output setting completed

## ■[F50] Relative humidity OUT1 setting

This function can be changed only when the product is compatible with IO-Link and IO-Link is enabled (set in [F0]).

It will link with [F1] setting when relative humidity is selected for the output operating mode of [F1] OUT1 setting.

### <Operation>

Press the UP or DOWN button in function selection mode to display [F50].

Press the SET button. ↓ Move to output mode setting.

#### Output mode setting

Press the UP or DOWN button to select the output mode.

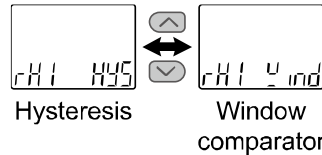

Press the SET button to save the setting. ↓ Move to reversed output setting.

#### Reversed output setting

Press the UP or DOWN button to select reversed output.

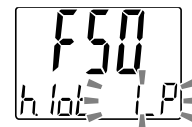
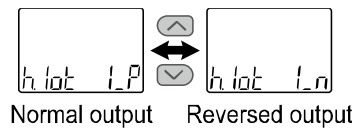

Press the SET button to save the setting. ↓ Move to relative humidity setting.

#### Relative humidity setting

Set the relative humidity based on the setting method on page 28.

For hysteresis mode: [h.P\_1]

For window comparator mode: [h.P1L][h.P1H]

"P" is changed to "n" as [h.P\_1] → [h.n\_1] when reversed output is selected.



Press the SET button to save the setting. ↓ Move to hysteresis setting.

#### Hysteresis setting

Set the hysteresis based on the setting method on page 28.

For hysteresis mode: [h.H\_1]

For window comparator mode: [h.H1]



Press the SET button to save the setting. ↓ Return to function selection mode.

[F50] Relative humidity OUT1 setting completed

## ■[F51] Relative humidity OUT2 setting

This function can be changed only when the product is compatible with IO-Link and IO-Link is enabled (set in [F0]).

It will link with [F2] setting when relative humidity is selected for the output operating mode of [F2] OUT2 setting.

### <Operation>

Press the UP or DOWN button in function selection mode to display [F51].

Press the SET button. ↓ Move to output mode setting.

#### Output mode setting

Press the UP or DOWN button to select the output mode.

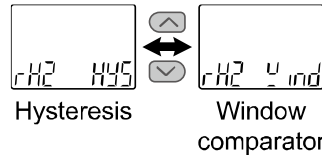

Press the SET button to save the setting. ↓ Move to reversed output setting.

#### Reversed output setting

Press the UP or DOWN button to select reverse output.

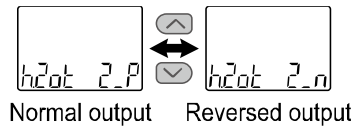

Press the SET button to save the setting. ↓ Move to relative humidity setting.

#### Relative humidity setting

Set the relative humidity based on the setting method on page 28.

For hysteresis mode: [h.P\_2]

For window comparator mode: [h.P2L][h.P2H]

"P" is changed to "n" as [h.P\_2] → [h.n\_2] when reversed output is selected.

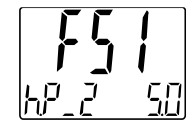

Press the SET button to save the setting. ↓ Move to hysteresis setting.

#### Hysteresis setting

Set hysteresis based on the setting method on page 28.

For hysteresis mode: [h.H\_2]

For window comparator mode: [h.H2]



Press the SET button to save the setting. ↓ Return to function selection mode.

[F51] Relative humidity OUT2 setting completed

## ■ [F52] Temperature OUT1 setting

This function can be changed only when the product is compatible with IO-Link and IO-Link is enabled (set in [F0]).

It will link with [F1] setting when the temperature is selected for the output operating mode of [F1] OUT1 setting.

### <Operation>

Press the UP or DOWN button in function selection mode to display [F52].

Press the SET button. ↓ Move to output mode setting.

#### Output mode setting

Press the UP or DOWN button to select the output mode.

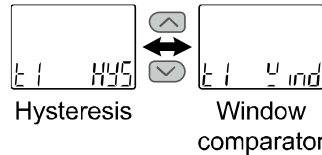

Press the SET button to save the setting. ↓ Move to reversed output setting.

#### Reversed output setting

Press the UP or DOWN button to select reversed output.

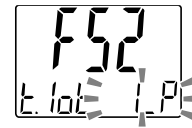
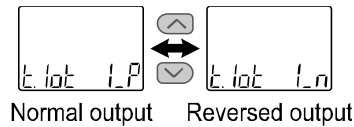

Press the SET button to save the setting. ↓ Move to relative humidity setting.

#### Temperature setting

Set the temperature based on the setting method on page 28.

For hysteresis mode: [t.P\_1]

For window comparator mode: [t.P1L][t.P1H]

"P" is changed to "n" as [t.P\_1] → [t.n\_1] when reversed output is selected.



Press the SET button to save the setting. ↓ Move to hysteresis setting.

#### Hysteresis setting

Set the hysteresis based on the setting method on page 28.

For hysteresis mode: [t.H\_1]

For window comparator mode: [t.H1]



Press the SET button to save the setting. ↓ Return to function selection mode.

[F52] Temperature OUT1 setting completed

## ■[F53] Temperature OUT2 setting

This function can be changed only when the product is compatible with IO-Link and IO-Link is enabled (set in [F0]).

It will link with [F2] setting when the temperature is selected for the output operating mode of [F2] OUT2 setting.

### <Operation>

Press the UP or DOWN button in function selection mode to display [F53].

Press the SET button. ↓ Move to output mode setting.

#### Output mode setting

Press the UP or DOWN button to select the output mode.

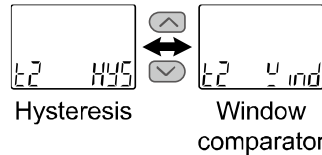

Press the SET button to save the setting. ↓ Move to reversed output setting.

#### Reversed output setting

Press the UP or DOWN button to select reversed output.

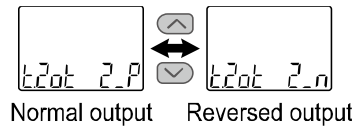

Press the SET button to save the setting. ↓ Move to relative humidity setting.

#### Temperature setting

Set the temperature based on the setting method on page 28.

For hysteresis mode: [t.P\_2]

For window comparator mode: [t.P2L][t.P2H]

"P" is changed to "n" as [t.P\_2] → [t.n\_2] when reversed output is selected.

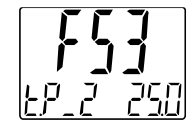

Press the SET button to save the setting. ↓ Move to hysteresis setting.

#### Hysteresis setting

Set the hysteresis based on the setting method on page 28.

For hysteresis mode: [t.H\_2]

For window comparator mode: [t.H2]



Press the SET button to save the setting. ↓ Return to function selection mode.

[F53] Temperature OUT2 setting completed



## ■[F80] Display off mode setting

Display off mode can be selected.

This function will turn the display OFF if no buttons are pressed for 30 seconds.

### <Operation>

Press the UP or DOWN button in function selection mode to display [F80].

Press the SET button. ↓ Move to display off mode setting.

#### Display off mode setting

Press the UP or DOWN and select display off mode.

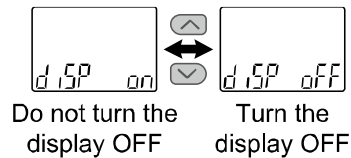
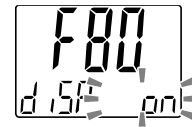

Press the SET button to save the setting. ↓ Return to function selection mode.

[F80] Display off mode setting completed

When the product is in display off mode, any key operation will return the display to a normal operation. When the key operation is not performed for 30 seconds, the display will revert to display off mode (Only in measurement mode).

During display off mode, [ \_ \_ ] flashes on the sub display and the operation LED is turned ON (only when the switch is ON).

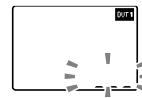

When switched ON

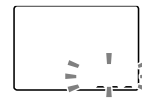

When switched OFF

## ■[F81] Security code input setting

This function is for setting a security code to lock the buttons and for changing the security code.

### <Operation>

Press the UP or DOWN button in function selection mode to display [F81].

Press the SET button. ↓ Move to security code entry setting.

#### Security code entry setting

Press the UP or DOWN button to enter a security code.

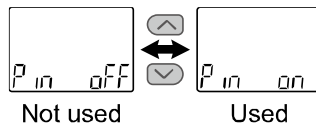

When [on] (used) is selected

Press the SET button to save the setting. ↓ Move to security code setting confirmation.

#### Security code setting confirmation

Press the UP or DOWN button to enter the security code on the sub display (right).

(The default setting is [000]) \*

For instructions on how to enter a security code, refer to "How to enter and change the security code" on page 71.

If the security code entered is incorrect, [FAL] will be displayed, and the security code must be entered again.

If the wrong security code is entered 3 times, [nG] is displayed and the device returns to function selection mode.



When [oFF] (not used) is selected

Press the SET button to return to function selection mode.

Press the SET button for 1 second to save the setting.

↓ Move to change the security code setting.

### Change the security code setting

Press the UP or DOWN button to enter the security code on the main display. \*  
For instructions on how to enter a security code, refer to "How to enter and change the security code" on page 71.

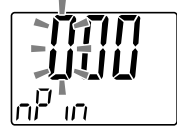

After entry, press the SET button for 1 second to let the changed security code start flashing.  
(At this point, the security code has not been changed.)  
Press the UP or DOWN button to return to the setting step.



Press the SET button to save the setting.

Return to function selection mode.

[F81] Security code input setting completed

If the security code function is enabled, it will be necessary to input a security code to release the key lock.

\*: If no key is pressed for 30 seconds or longer during security code entry, the product will return to function selection mode.

● **Special function setting**

■ **[F90] Setting of all functions**

All functions can be set in series.

**<Operation>**

Press the UP or DOWN button in function selection mode to display [F90].

Press the SET button. ↓ Move to setting of all functions.

**Setting of all functions**

Press the UP or DOWN button to select all functions.



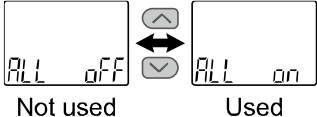

Not used                  Used

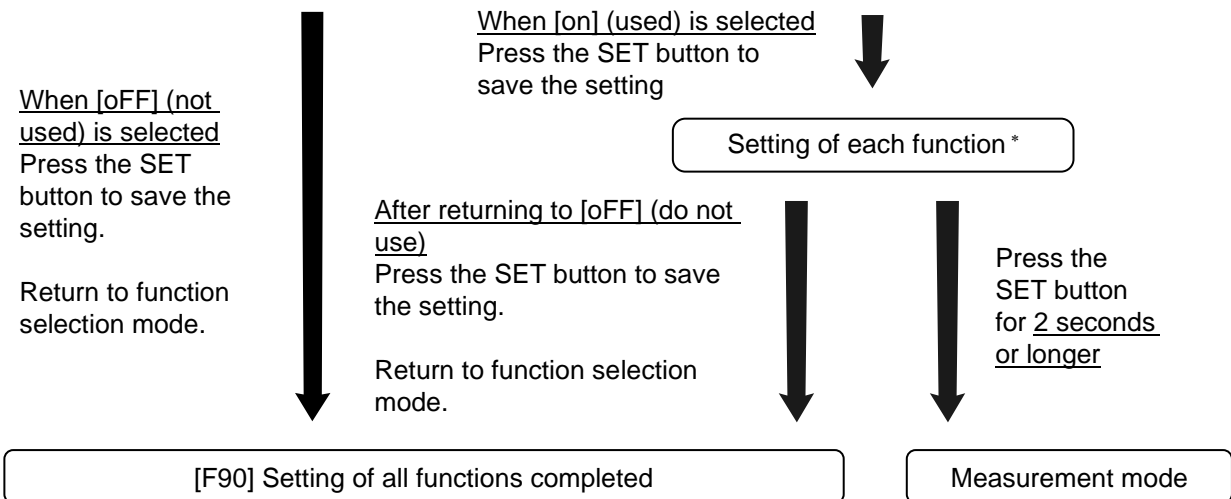

\*: Setting of each function

Each time the SET button is pressed, the display moves to the next function in the sequence shown in setting each function on page 61.

Change the settings using the UP and DOWN buttons.

For details on how to set each function, refer to the relevant function setting section in this manual.

●Setting each function

Sequence	Function
1	Selection of display units
2	Setting of switch output PNP/NPN specifications
3	IO-Link enabled/disabled
4	OUT1 output operation mode
5	OUT1 output mode
6	OUT1 reversed output
7	OUT1 relative humidity or temperature
8	OUT1 hysteresis
9	Display colour
10	OUT2 output operating mode
11	OUT2 output mode
12	OUT2 reversed output
13	OUT2 relative humidity or temperature
14	OUT2 hysteresis
15	Display colour
16	Digital filter
17	Display value fine adjustment
18	Display
19	Display resolution
20	Analogue output
21	Relative humidity OUT1
22	Relative humidity OUT2
23	Temperature OUT1
24	Temperature OUT2
25	Display off mode
26	Security code entry

\*: Press the SET button for 2 seconds or longer to return from any setting item to measurement mode.

\*: Functions that are set before returning to the measurement mode are maintained.

\*: Some setting items are not supported depending on the part number.

\*: 21 to 24: Can only be set if the product is IO-Link compatible and IO-Link is enabled.

## ■[F96] Cycle time check

The average cycle time during IO-Link communication can be checked.

\*: If switch output is selected, the cycle time cannot be checked.

This function can only be available if the product is IO-Link compatible and IO-Link enabled (set with [F0]).

### <Operation>

Press the UP or DOWN button in function selection mode to display [F96].

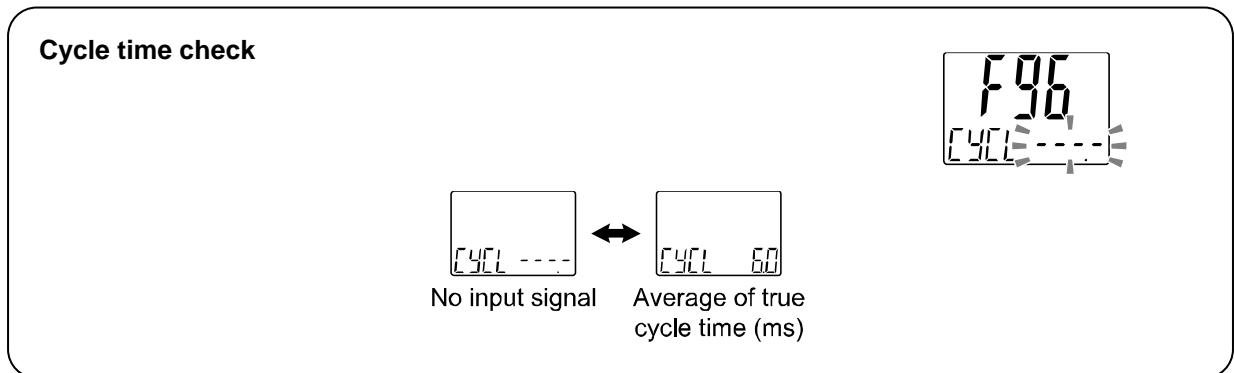

## ■[F98] Output check

Correct operation of the switch output can be checked.  
The output can be turned ON/OFF manually.

### <Operation>

Press the UP or DOWN button in function selection mode to display [F98].

Press the SET button. ↓ Move to output check.

**Output check**

Press the UP or DOWN button to select the output check.

Normal output  
(Output not checked)

Forced output  
(Output is checked)

When [F] (forced output) is selected  
Press the SET button to save the setting.

Move to OUT1 output check.

**OUT1 output check**

Press the UP or DOWN button to select OUT1 output check.

Forced output  
OFF

Forced output  
ON

Press the SET button to save the setting.

Move to OUT2 output check.

**OUT2 output check**

Press the UP or DOWN button to select OUT2 output check.

Forced output  
OFF

Forced output  
ON

Press the SET button to save the setting.

Move to analogue output check.

When [n] (normal output) is selected  
Press the SET button to save the setting.

Return to function selection mode.



### Analogue output check

The rated upper and lower values can be forced output by pressing the UP or DOWN button.

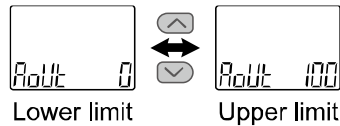

\*: With analogue output only.

Press the SET button to save the setting.



Move to process data relative humidity OUT1 output check.

### Process data relative humidity OUT1 output check (Only during IO-Link communication)

Press the UP or DOWN button to select process data relative humidity OUT1 output check.

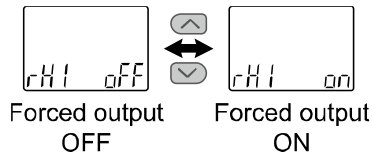

\*: This function is available with IO-Link communication.  
\*: Refer to page 73 for details.

Press the SET button to save the setting.



Move to process data relative humidity OUT2 output check.

### Process data relative humidity OUT2 output check (Only during IO-Link communication)

Press the UP or DOWN button to select process data relative humidity OUT2 output check.

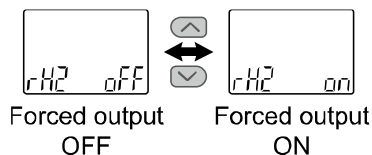

\*: This function is available with IO-Link communication.  
\*: Refer to page 73 for details.

Press the SET button to save the setting.



Move to process data temperature OUT1 output check.







**Process data temperature OUT1 output check  
(Only during IO-Link communication)**

Press the UP or DOWN button to select process data temperature OUT1 output check.

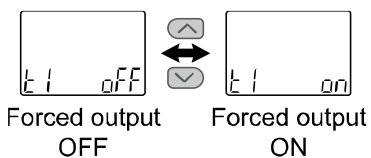

\*: This function is available with IO-Link communication.  
\*: Refer to page 73 for details.

Press the SET button to save the setting.



Move to process data temperature OUT2 output check.

**Process data temperature OUT2 output check  
(Only during IO-Link communication)**

Press the UP or DOWN button to select process data temperature OUT2 output check.

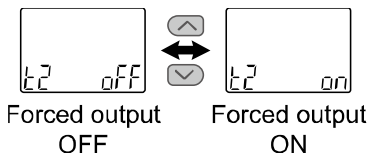

\*: This function is available with IO-Link communication.  
\*: Refer to page 73 for details.

Press the SET button to save the setting.



Move to process data temperature diagnostic output check.

**Process data temperature diagnostic output check  
(Only during IO-Link communication)**

Press the UP or DOWN button to select process data temperature diagnosis output check.

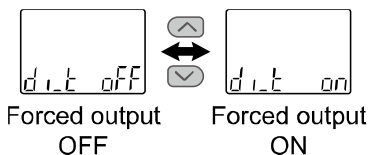

\*: This function is available with IO-Link communication.  
\*: Refer to page 73 for details.

Press the SET button to save the setting.



Move to process data error diagnostics output check.





**Process data error diagnostics output check  
(Only during IO-Link communication)**

Press the UP or DOWN button to select process data error diagnostics output check.

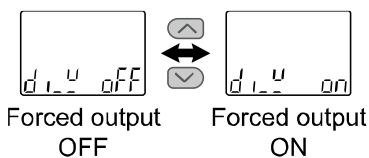

\*: This function is available with IO-Link communication.  
\*: Refer to page 73 for details.

Press the SET button to save the setting.



Move to process data system error diagnostics output check.

**Process data system error diagnostics output check  
(Only during IO-Link communication)**

Press the UP or DOWN button to select process data system error diagnostics output check.

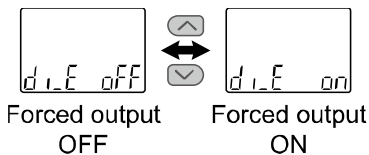

\*: This function is available with IO-Link communication.  
\*: Refer to page 73 for details.

Press the SET button to save the setting.



Move to process data relative humidity measurement value.

**Process data relative humidity measurement value  
(Only during IO-Link communication)**

The rated upper and lower limit values can be forced output.

Select the upper and lower values by pressing the UP or DOWN button.

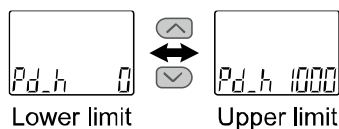

\*: This function is available with IO-Link communication.  
\*: Refer to page 73 for details.

Press the SET button to save the setting.



Move to process data temperature measurement value.



**Process data temperature measurement value  
(Only during IO-Link communication)**

The rated upper and lower limit values can be forced output.  
Select the upper and lower values by pressing the UP or DOWN button.

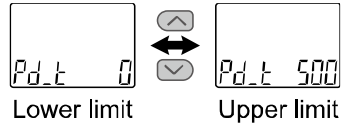

\*: This function is available with IO-Link communication.

\*: Refer to page 73 for details.

Press the SET button,  
After returning to [n] (Normal output)  
Press the SET button to save the  
setting.

Return to function selection mode.

[F98] Output check setting completed

\*: Press the SET button for 2 seconds or longer to return from any setting item to measurement mode.

\*: For the analogue output specification, there is no setting after the process data relative humidity OUT1 output check (only during IO-Link communication).

## ■[F99] Reset to default setting

If the product settings are uncertain, the factory default setting can be restored.

### <Operation>

Press the UP or DOWN button in function selection mode to display [F99].

Press the SET button. ↓ Move to reset to default settings.

#### Reset to default setting

Press the UP or DOWN button to select reset to default setting.

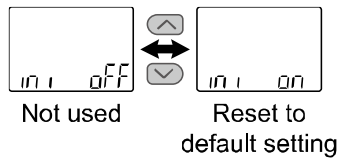

When [oFF] (not used) is selected

Press the SET button to save the setting.

Return to function selection mode.

When [on] (reset to default setting) is selected

Press the SET and DOWN buttons simultaneously for 5 seconds or longer.

The factory default settings are restored and return to function selection mode.

[F99] Reset to default setting completed

## Other Settings

### ○Peak value/bottom value display function

The maximum (minimum) relative humidity/temperature from when the power is supplied is detected and updated. In peak/bottom display mode, the relative humidity/temperature is displayed.

Press the UP or DOWN button in measurement mode to switch the sub display (left) as shown below.

Peak/bottom values are displayed on the sub display (right) at the same time as the current relative humidity value or temperature value is displayed on the main display.

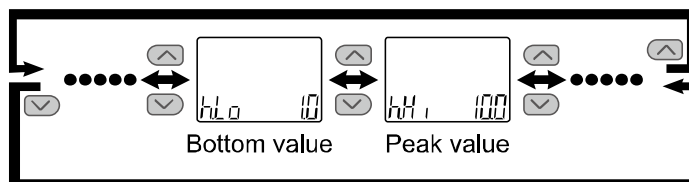

\*: For temperature, [h] will be [t].

Peak/bottom value is maintained even if the power supply is cut.

When the SET and DOWN buttons are pressed and held for 1 second or longer simultaneously while the peak/bottom value is displayed, the sub display (right) displays [- - -] and the maximum (minimum) relative humidity/temperature value is cleared.

### ○Key-lock function

The key lock function is used to prevent errors due to unintentional changes in the set values. Press the SET button when the key-lock is enabled to display [LoC] on the sub display (Right) for 1 second.

(Each setting and peak/bottom values can be displayed with the UP and DOWN buttons. In that case, the sub display will return after 30 seconds).

#### <Operation – Without security code>

- (1) Press the SET button for 5 seconds or longer in measurement mode. When [oPE] is displayed on the main display, release the button.

The current setting "LoC" or "UnL" will be displayed on the sub display.

(To release the key-lock, repeat the above operation).

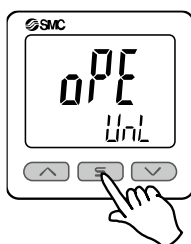

- (2) Press the UP or DOWN button to select Lock/Unlock and then press the SET button to enable the setting.

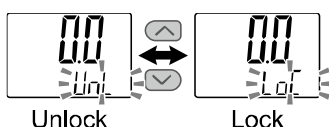

## <Operation – With security code>

### •Locking

- (1) Press the SET button for 5 seconds or longer in measurement mode. When [oPE] is displayed on the main display, release the button.  
The current setting "LoC" or "UnL" will be displayed on the sub display.

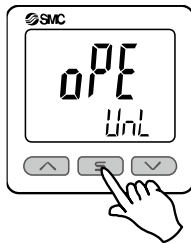

- (2) Press the UP or DOWN button to select Lock [LoC] and then press the SET button to enable the setting.

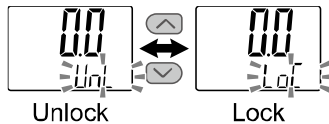

### •Unlocking

- (1) Press the SET button for 5 seconds or longer in measurement mode. When [oPE] is displayed on the main display, release the button.  
The current setting "LoC" or "UnL" will be displayed on the sub display.



- (2) Press the UP or DOWN button to select unlock [UnL] and then press the SET button to enable the setting. Security code entry is required.

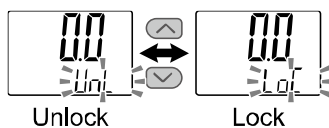

- (3) For instructions on how to enter a security code, refer to "How to enter and change the security code" on page 71.

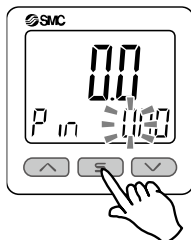

- (4) If the entered security code is correct, the main display indicates [UnL] and pressing any of the UP, SET, and DOWN buttons disables the key lock. Then it returns to the measurement mode.  
If the security code entered is incorrect, [FAL] will be displayed, and the security code must be entered again. If the wrong security code is entered 3 times, [LoC] is displayed and the device returns to measurement mode.

● **How to enter and change the security code**

The left most digit starts flashing.

Press the UP or DOWN button to specify a value.

Press the SET button to make the next digit to the right flash.

(If the SET button is pressed at the last digit, the first digit will start flashing.)

After the setting is completed, press and hold the SET button for 1 second or longer.

(If an operation is not performed for 30 seconds or longer during entry or change of a security code, it returns to the measurement mode.)

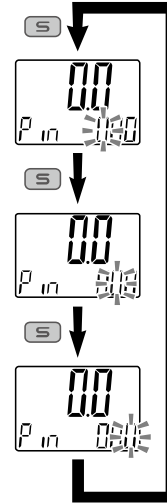

## IO-Link Specifications

### ■ Summary of IO-Link function

#### ○ Communication function

This product can check the measurement value, diagnostic information, and switch output status using cyclic data communication via the IO-Link system.

#### ○ Product status monitoring function

This function monitors the product status via the IO-Link communication.

- Detects error conditions (internal hardware error, OUT 2 short-circuit status, etc.).
- Detects warning conditions (product internal error, measurement temperature error, etc.).

#### ○ Data storage function

The data storage function stores the IO-Link device parameter settings to the IO-Link master.

With the IO-Link data storage function, the IO-link device can be replaced easily without re-setting the equipment construction or setting parameters.

When the device parameters are set and downloaded to the device using the IO-Link setting tool, the parameters in the downloaded device will be enabled.

After that, these parameters are uploaded to the data storage in the master by system command (back-up communication command).

When the device is replaced with the same type of IO-Link device due to failure, etc., the parameter settings stored in the master are downloaded automatically, and the device can be operated with the parameter settings of the previous device.

Device parameter setting is applicable to 3 types of back-up levels of the master setting ("Disable," "Back-up/Restore," and "Restore").

"Back-up" implies that an upload is enabled and "restore" implies that download is enabled.

### ■ Communication specification

IO-Link type	Device
IO-Link version	V.1.1
Communication speed	COM2 (38.4 kbps)
Minimum cycle time	3.8 ms
Process data length	Input Data: 6 bytes, Output Data: 0 bytes
On-request data communication	Supported
Data storage function	Supported
Event function	Supported



## ■ Process data

Process data is the data exchanged periodically between the master and the device.

This product process data consists of switch output status, error diagnostics result, and relative humidity and temperature measurement values.

(Refer to the table below).

Bit offset	Item	Remarks
0	Relative humidity OUT1 output	0: OFF 1: ON
1	Relative humidity OUT2 output	0: OFF 1: ON
2	Temperature OUT1 output	0: OFF 1: ON
3	Temperature OUT2 output	0: OFF 1: ON
9	Temperature diagnostics	0: Normal 1: Abnormal Outside display range (when HHH/LLL is generated)
13	Fixed output	0: Normal output 1: Fixed output
14	Error diagnostics	0: Normal 1: Abnormal Over current, when IO-Link master version error is generated
15	System error diagnostics	0: Normal 1: Abnormal When an error other than error diagnostics is generated
16 to 31	Temperature measurement value	16-bit signed integer
32 to 47	Relative humidity measurement value	16-bit signed integer

Bit offset	47	46	45	44	43	42	41	40	39	38	37	36	35	34	33	32
Item	Relative humidity measurement value (16-bit signed integer)															

Bit offset	31	30	29	28	27	26	25	24	23	22	21	20	19	18	17	16
Item	Temperature measurement value (16-bit signed integer)															

Bit offset	15	14	13	12	11	10	9	8	7	6	5	4	3	2	1	0
Item	System error diagnostics	Error diagnostics	Fixed output	0			Temperature diagnostics	0					Temperature OUT2	Temperature OUT1	Relative humidity OUT2	Relative humidity OUT1

- The data process type of this product is Big-Endian.

When the transmission method of the upper communication is Little-Endian, the byte sequence will be changed.

Refer to the table below for the Endian type of the major upper communication.

Endian type	Upper communication protocol
Big-Endian type	PROFIBUS, PROFINET, etc.
Little-Endian type	EtherNET/IP, EtherCAT, CC-Link IE Field, etc.

○Units specification and measurement value (PD)

	Units	Display/setting range
Relative humidity	%R.H.	0.0 to 100.0
	Measurement value (PD)	0.0 to 1000
Temperature	°C	-5.0 to 55.0
	°F	23 to 131
	Measurement value (PD)	-50 to 550

○Conversion equation of process data, relative humidity/temperature measurement value

[Inclination and intercept to the unit specification]

	Units	Inclination a	Intercept b
Relative humidity	%R.H.	0.1	0
Temperature	°C	0.1	0
	°F	0.18	26.24

[Calculation example]

**(1) Conversion from process data to relative humidity measurement value  
(When PD = 100)**

$$\begin{aligned}
 Pr &= a \times (PD) + b \\
 &= 0.1 \times 100 + 0 \\
 &= 10.0 \text{ [%R.H.]}
 \end{aligned}$$

**(2) Conversion from temperature measurement value to process data  
(When unit specification: °C, Pr = 30.0 [°C])**

$$\begin{aligned}
 (PD) &= (Pr - b) / a \\
 &= (30.0 - 0) / 0.1 \\
 &= 300
 \end{aligned}$$

## ■IO-Link parameter setting

### ○IODD file

IODD (I/O Device Description) is a definition file that provides all properties and parameters required for establishing functions and communication of the device.

The IODD includes the main IODD file and a set of image files such as the vendor logo, device picture, and device icon.

The IODD file of each product is shown below.

	Product number	IODD file *1
1	PSH-L2(-M)-*	SMC-PSH-L2-yyyymmdd-IODD1.1

\*1: "yyyymmdd" indicates the file preparation date of the file. yyyy is the year, mm is the month, and dd is the date.

The IODD file can be downloaded from the SMC Website (<https://www.smcworld.com>).

### ○Service data

The parameters that can be read or written by simple access parameters (direct parameters page) and ISDU parameters applicable to various parameters and commands are shown below.

\*: The parameter data of this product is the Big-Endian type.

When the transmission method of the upper communication is Little-Endian, the byte sequence will be changed.

### ●Direct parameter page 1

DPP1 address	Access	Parameter name	Default (decimal number)	Details
0x07	R	Vendor ID	0x0083(131)	"SMC Corporation"
0x08				
0x09	R	Device ID	0x00028A(650)	"PSH-L2(-M)-*"
0x0A				
0x0B				

●ISDU parameter

Index (Decimal number)	Subindex	Access *1	Parameter	Default	Remarks
0x0002 (2)	0	W	System command	-	Refer to "System command" (page 76)
0x000C (12)	0	R/W	Device access lock	0x0000	Refer to "Device access lock" (page 77)
0x0010 (16)	0	R	Vender name	SMC Corporation	
0x0011 (17)	0	R	Vender text	www.smcworld.com	
0x0012 (18)	0	R	Product name	Example: PSH-L2	
0x0013 (19)	0	R	Product ID	Example: PSH-L2	
0x0014 (20)	0	R	Product text	Digital humidity temperature switch	
0x0015 (21)	0	R	Serial number	Example: "xxxxxxxx"	●Indicated by 8-digit ●16 octets fixed character string
0x0016 (22)	0	R	Hardware version	HW-Vx.y	x: Large-scale revision number y: Small-scale revision number
0x0017 (23)	0	R	Software version	FW-Vx.y	x: Large-scale revision number y: Small-scale revision number
0x0024 (36)	0	R	Device status parameter	-	Refer to "Device status parameter" (page 77)
0x0025 (37)	0	R	Device details status parameter	-	Refer to "Device details status parameter" (page 77)
0x0028 (40)	0	R	Process data input	-	The latest values of the process data can be loaded.

\*1: R: Read, W: Write.

●System command (Index 2)

In the ISDU index 0x002 SystemCommand (system command), the command shown in the table below will be issued.

The button of each system command is displayed on the IO-Link setting tool (excluding "ParamDownloadStore").

Click the button to send the system command to the product.

Writable commands are shown below.

Data type: 8-bit UInteger

Value (Decimal number)	Definition of status	Details
0x80(128)	Device Reset	Restart the device
0x81(129)	Application Reset	Clear the peak/bottom value
0x82(130)	Restore Factory Settings	Restore the set values to the factory default values.

- Device access lock parameter (Index 12)  
Device access lock conditions are shown below.  
Data type: 16-bit Record

Value (Decimal number)	Details
0x0000(0)	Key lock release, DS lock release (Default)
0x0002(2)	Key lock release, DS lock
0x0008(8)	Key lock, DS lock release
0x000A(10)	Key lock, DS Lock

**[Key lock]**

Function that prevents changes to the settings (disables button operation).

While the keys are locked, setting changes or restoring by data storage (rewriting of parameter set data) through communication are performed.

**[Data storage lock (DS lock)]**

Data storage function can be disabled by locking the data storage. In this case, access is rejected for data storage backup and restore.

- Device status parameter (Index 36)  
The readable device status are shown below.  
Data type: 8-bit UInteger

Value (Decimal number)	Definition of status	Details
0x00(0)	Normal operation	-
0x01(1)	Maintenance is required	Not available
0x02(2)	Out of specification	Above the measurement temperature range upper limit Below the measurement temperature range lower limit
0x03(3)	Function check	Not available
0x04(4)	Failure	Internal failure of digital temperature & humidity switch

- Device detail status parameter (Index 37)  
Event details of the readable device status are shown below.

Layout	Event details	Event class		Event code
		Definition	Value	
1	Internal failure of digital temperature & humidity switch	Error	0xF4	0x8D03
2	Internal failure of digital temperature & humidity switch	Error	0xF4	0x8D0F
3	Internal failure of digital temperature & humidity switch	Error	0xF4	0x8D04
4	Internal failure of digital temperature & humidity switch	Error	0xF4	0x8D05
5	Internal failure of digital temperature & humidity switch	Error	0xF4	0x8D01
6	Internal failure of digital temperature & humidity switch	Error	0xF4	0x8D06
7	Internal failure of digital temperature & humidity switch	Error	0xF4	0x8CD0
8	OUT2 over current	Error	0xF4	0x8CC0
9	Above the temperature measurement range	Warning	0xE4	0x8D61
10	Below the temperature measurement range	Warning	0xE4	0x8D71
11	-	-	0x00	0x0000
12	-	-	0x00	0x0000
13	Data storage upload request	Notification	0x54	0xFF91

●Product individual parameters

Index (Decimal number)	Subindex	Access	Parameter name	Data storage	Data type	Default (Decimal number)	Details
0x03E8 (1000)	0	R/W	Unit (Selection of display units)	Y	U8	PSH-L2(-M): 0	Set the display units. 0: Centigrade (°C) 1: Fahrenheit (°F)
0x03F2 (1010)	0	R/W	CoL (Select display colour)	Y	U8	0x03 (3)	Set the display colour. 0: Red (Constant red) 1: Wht (Constant white) 2: 1SoW (White when OUT1 is ON) 3: 1Sor (Red when OUT1 is ON) 4: 2SoW (White when OUT2 is ON) 5: 2Sor (Red when OUT2 is ON)
0x03FC (1020)	0	R/W	n or P (Select NPN/PNP)	Y	U8	0x01 (1)	Set the switch output specification. 0: NPN 1: PNP
0x041A (1050)	0	R/W	toP (Select display mode)	Y	U8	0x00 (0)	Set the display mode of the main display. 0: rH (Relative humidity) 1: t (Temperature) 2: No display
0x04B0 (1200)	1	R/W	oUt1 (Select OUT1 output operating mode)	Y	U8	0x00 (0)	Set the OUT1 output operating mode. 0: rH1 (Relative humidity) 1: t1 (Temperature) 2: Err (Error output) 3: oFF (Output off)
	2	R/W	E.1ot (Select normal/reversed output when OUT1 error output is selected)	Y	U8	0x01 (1)	Set normal/reversed output when OUT1 error output is selected. 0: 1_P (Normal output) 1: 1_n (Reversed output)
0x04BA (1210)	1	R/W	rH1 (Select output mode of relative humidity OUT1)	Y	U8	0x00 (0)	Set the output mode of relative humidity OUT1. 0: HYS (Hysteresis mode) 1: Wind (Window comparator mode)
	2	R/W	h.1ot (Select normal/reversed output of relative humidity OUT1)	Y	U8	0x00 (0)	Set the normal/reversed output of relative humidity OUT1. 0: 1_P (Normal output) 1: 1_n (Reversed output)

•Product individual parameters (continued)

Index (Decimal number)	Subindex	Access	Parameter name	Data storage	Data type	Default (Decimal number)	Details
0x04C4 (1220)	1	R/W	h.P_1 (h.n_1) (Setting of relative humidity OUT1 output set value)	Y	S16	0x0032 (50)	Set the output set value of relative humidity OUT1. Settable values 0x0000 to 0x03E8 (0 to 1000)
	2	R/W	h.H_1 (Setting of relative humidity OUT1 hysteresis)	Y	S16	0x000A (10)	Set the hysteresis of relative humidity OUT1. Settable values 0x0000 to 0x03E8 (0 to 1000)
	3	R/W	h.P1L (h.n1L) (Setting of relative humidity OUT1 window comparator mode set value (Lower side))	Y	S16	0x0032 (50)	Set the window comparator mode set value of relative humidity OUT1 (Lower side) Settable values 0x0000 to 0x03E8 (0 to 1000)
	4	R/W	h.P1H (h.n1H) (Setting of relative humidity OUT1 window comparator mode set value (Upper side))	Y	U16	0x0064 (100)	Set the window comparator mode set value of relative humidity OUT1 (Upper side) Settable values 0x0000 to 0x03E8 (0 to 1000)
	5	R/W	h.H1 (Setting of relative humidity OUT1 window comparator mode hysteresis)	Y	S16	0x000A (10)	Set hysteresis of the window comparator mode of relative humidity OUT1. Settable values 0x0000 to 0x03E8 (0 to 1000)
0x04CE (1230)	1	R/W	t1 (Select temperature OUT1 output mode)	Y	U8	0x00 (0)	Set the output mode of temperature OUT1. 0: HYS (Hysteresis mode) 1: Wind (Window comparator mode)
	2	R/W	t.1ot (Select temperature OUT1 normal/reversed output)	Y	U8	0x00 (0)	Set the normal/reversed output of relative humidity OUT1. 0: 1_P (Normal output) 1: 1_n (Reversed output)

●Product individual parameters (continued)

Index (Decimal number)	Subindex	Access	Parameter name	Data storage	Data type	Default (Decimal number)	Details
0x04D8 (1240)	1	R/W	t.P_1 (t.n_1) (Setting of temperature OUT1 output set value)	Y	S16	0x00FA (250)	Set the output set value of temperature OUT1. Settable values 0xFFCE to 0x0226 (-50 to 550)
	2	R/W	t.H_1 (Setting of temperature OUT1 hysteresis)	Y	S16	0x0032 (50)	Set the hysteresis of temperature OUT1. Settable values 0x0000 to 0x0258 (0 to 600)
	3	R/W	t.P1L (t.n1L) (Setting of temperature OUT1 window comparator mode set value (Lower side))	Y	S16	0x00C8 (200)	Set the window comparator mode set value of temperature OUT1 (Lower side). Settable values 0xFFCE to 0x0226 (-50 to 550)
	4	R/W	t.P1H (t.n1H) (Setting of temperature OUT2 window comparator mode set value (Upper side))	Y	S16	0x012C (300)	Set the window comparator mode set value of temperature OUT1 (Upper side). Settable values 0xFFCE to 0x0226 (-50 to 550)
	5	R/W	t.H1 (Setting of temperature OUT1 window comparator mode hysteresis)	Y	S16	0x0032 (50)	Set hysteresis of the window comparator mode of temperature OUT1. Settable values 0x0000 to 0x0258 (0 to 600)
0x0578 (1400)	1	R/W	oUt2 (Select OUT2 output operation mode)	Y	U8	0x01 (1)	Set the output operating mode of OUT2. 0: rH2 (Relative humidity) 1: t2 (Temperature) 2: Err (Error output) 3: oFF (Output off)
	2	R/W	E.2ot (Select normal/reversed output when OUT2 error output is selected)	Y	U8	0x01 (1)	Set normal/reversed output when OUT2 error output is selected. 0: 1_P (Normal output) 1: 1_n (Reversed output)



●Product individual parameters (continued)

Index (Decimal number)	Subindex	Access	Parameter name	Data storage	Data type	Default (Decimal number)	Details
0x0582 (1410)	1	R/W	rH2 (Select relative humidity OUT2 output mode)	Y	U8	0x00 (0)	Set the output mode of relative humidity OUT2. 0: HYS (Hysteresis mode) 1: Wind (Window comparator mode)
	2	R/W	h.2ot (Select normal/reversed output of relative humidity OUT2)	Y	U8	0x00 (0)	Set the normal/reversed output of relative humidity OUT2. 0: 2_P (Normal output) 1: 2_n (Reversed output)
0x058C (1420)	1	R/W	h.P_2(h.n_2) (Setting of relative humidity OUT2 output set value)	Y	S16	0x0032 (50)	Set the output set value of relative humidity OUT2. Settable values 0x0000 to 0x03E8 (0 to 1000)
	2	R/W	h.H_2 (Setting of relative humidity OUT2 hysteresis)	Y	S16	0x000A (10)	Set the hysteresis of relative humidity OUT2. Settable values 0x0000 to 0x03E8 (0 to 1000)
	3	R/W	h.P2L (h.n2L) (Setting of relative humidity OUT2 window comparator mode set value (Lower side))	Y	S16	0x0032 (50)	Set the window comparator mode set value of relative humidity OUT2 (Lower side). Settable values 0x0000 to 0x03E8 (0 to 1000)
	4	R/W	h.P2H (h.n2H) (Setting of relative humidity OUT2 window comparator mode set value (Upper side))	Y	S16	0x0064 (100)	Set the window comparator mode set value of relative humidity OUT2 (Upper side) Settable values 0x0000 to 0x03E8 (0 to 1000)
	5	R/W	h.H2 (Setting of relative humidity OUT2 window comparator mode hysteresis)	Y	S16	0x000A (10)	Set hysteresis of the window comparator mode of relative humidity OUT2. Settable values 0x0000 to 0x03E8 (0 to 1000)

•Product individual parameters (continued)

Index (Decimal number)	Subindex	Access	Parameter name	Data storage	Data type	Default (Decimal number)	Details
0x0596 (1430)	1	R/W	t2 (Select temperature OUT2 output mode)	Y	U8	0x00 (0)	Set the output mode of temperature OUT2. 0: HYS (Hysteresis mode) 1: Wind (Window comparator mode)
	2	R/W	t.2ot (Select temperature OUT2 normal/reversed output)	Y	U8	0x00 (0)	Set the normal/reversed output of relative humidity OUT2. 0: 2_P (Normal output) 1: 2_n (Reversed output)
0x05A0 (1440)	1	R/W	t.P_2 (t.n_2) (Setting of temperature OUT2 output setting value)	Y	S16	0x00FA (250)	Set the output setting value of temperature OUT2. Settable values 0xFFCE to 0x0226 (-50 to 550)
	2	R/W	t.H_2 (Setting of temperature OUT2 hysteresis)	Y	S16	0x0032 (50)	Set the hysteresis of temperature OUT2. Settable values 0x0000 to 0x0258 (0 to 600)
	3	R/W	t.P2L (t.n2L) (Setting of temperature OUT2 window comparator mode set value (Upper side))	Y	S16	0x00C8 (200)	Set the window comparator mode set value of temperature OUT2 (Lower side). Settable values 0xFFCE to 0x0226 (-50 to 550)
	4	R/W	t.P2H (t.n2H) (Setting of temperature OUT2 window comparator mode set value (Upper side))	Y	S16	0x012C (300)	Set the window comparator mode set value of temperature OUT2 (Upper side). Settable values 0xFFCE to 0x0226 (-50 to 550)
	5	R/W	t.H2 (Setting of temperature OUT2 window comparator mode hysteresis)	Y	S16	0x0032 (50)	Set hysteresis of the window comparator mode of temperature OUT2. Settable values 0x0000 to 0x0258 (0 to 600)
0x0708 (1800)	0	R/W	FiL (Digital filter)	Y	U16	0x0000 (0)	Set the digital filter. 0x0000 to 0x1770 (0 to 6000) 0.01 s increment

●Product individual parameters (continued)

Index (Decimal number)	Subindex	Access	Parameter name	Data storage	Data type	Default (Decimal number)	Details
0x0712 (1810)	0	R/W	h.FSC (Fine adjustment of relative humidity display value)	N	S16	0x0000 (0)	The displayed relative humidity can be adjusted in the range of ±5% R.D. (-50 to 50) 0.1% increment
0x0713 (1811)	0	R/W	t.FSC (Fine adjustment of temperature display value)	N	S16	0x0000 (0)	The displayed relative humidity can be adjusted in the range of ±5% R.D. (-50 to 50) 0.1% increment
0x07D0 (2000)	1	R/W	Sub (Select sub display)	Y	U8	0x00 (0)	Set the display type of sub display. 0: Std (Standard) 1: dUAL (2-value display) 2: o1Lv (OUT1 level bar) 3: o2Lv (OUT2 level bar) 4: LinE (Character string display) 5: OFF (Display OFF)
	2	R/W	Select display item in the standard setting	Y	U8	0x00 (0)	Refer to select display item in the standard setting
	3	R/W	Left side of select display item in 2-value display setting	Y	U8	0x00 (0)	Refer to select display item in 2-value display setting
	4	R/W	Right side of select display item in 2-value display setting	Y	U8	0x01 (1)	Refer to select display item in 2-value display setting
0x07DA (2010)	0	R/W	h.drE (Select relative humidity display resolution)	Y	U8	0x00 (0)	Set the relative humidity display resolution. 0: Normal resolution 1: Low resolution (1/10)
0x07DB (2011)	0	R/W	t.drE (Select temperature display resolution)	Y	U8	0x00 (0)	Set the temperature display resolution. 0: Normal resolution 1: Low resolution (1/10)
0x0960 (2400)	0	R/W	disp (Setting of display off mode)	Y	U8	0x00 (0)	Set the display off mode. 0: off 1: on
0x096A (2410)	0	R/W	Pin (Security code Used/Not used)	Y	U8	0x00 (0)	Set the use or unuse of the security code. 0: Unuse 1: Use
	1	R/W	Pin (Security code)	Y	U16	0x0000 (0)	Set the security code. 0 to 999

●Product individual parameters (continued)

Index (Decimal number)	Subindex	Access	Parameter name	Data storage	Data type	Default (Decimal number)	Details
0x0974 (2420)	1	R/W	LinE (Line name character setting_First character (Left end))	Y	U8	0x00 (0)	Refer to "Line name communication data."
	2	R/W	LinE (Line name character setting_Second character)	Y	U8	0x00 (0)	Refer to "Line name communication data."
	3	R/W	LinE (Line name character setting_Third character)	Y	U8	0x00 (0)	Refer to "Line name communication data."
	4	R/W	LinE (Line name character setting_Fourth character)	Y	U8	0x00 (0)	Refer to "Line name communication data."
	5	R/W	LinE (Line name character setting_Fifth character)	Y	U8	0x00 (0)	Refer to "Line name communication data."
	6	R/W	LinE (Line name character setting_Sixth character)	Y	U8	0x00 (0)	Refer to "Line name communication data."
	7	R/W	LinE (Line name character setting_Seventh character)	Y	U8	0x00 (0)	Refer to "Line name communication data."
	8	R/W	LinE (Line name character setting_Eighth character)	Y	U8	0x00 (0)	Refer to "Line name communication data."

•Product individual parameters (continued)

Index (Decimal number)	Subindex	Access	Parameter name	Data storage	Data type	Default (Decimal number)	Details
0x097E (2430)	1	R/W	LinE (Line name dot setting_First dot (Left end))	Y	U8	0x00 (0)	0: OFF (Dot off) 1: ON (Dot on)
	2	R/W	LinE (Line name dot setting_Second dot)	Y	U8	0x00 (0)	0: OFF (Dot off) 1: ON (Dot on)
	3	R/W	LinE (Line name dot setting_Third dot)	Y	U8	0x00 (0)	0: OFF (Dot off) 1: ON (Dot on)
	4	R/W	LinE (Line name dot setting_Fourth dot)	Y	U8	0x00 (0)	0: OFF (Dot off) 1: ON (Dot on)
	5	R/W	LinE (Line name dot setting_Fifth dot)	Y	U8	0x00 (0)	0: OFF (Dot off) 1: ON (Dot on)
	6	R/W	LinE (Line name dot setting_Sixth dot)	Y	U8	0x00 (0)	0: OFF (Dot off) 1: ON (Dot on)
0x1B58 (7000)	0	W	Test (Communication OUT output test)	N	U8	-	The PD becomes 1 when a fixed output has been received. 0: Normal output 1: Fixed output
0x1B62 (7010)	0	W	test (Output setting)	N	U8	-	Effective only when the communication OUT output test is a fixed output. 0x00: Relative humidity measurement value 0x01: Temperature measurement value 0x10: OUT1 output 0x11: OUT2 output 0x20: Relative humidity OUT1 bit 0x21: Relative humidity OUT2 bit 0x22: Temperature OUT1 bit 0x23: Temperature OUT2 bit 0xE1: Temperature diagnosis bit 0xFE: Error bit 0xFF: System error bit

●Product individual parameters (continued)

Index (Decimal number)	Subindex	Access	Parameter name	Data storage	Data type	Default (Decimal number)	Details
0x1F40 (8000)	0	R	Relative humidity PD conversion formula Inclination a	N	F32	-	Refer to Inclination and intercept to the unit specification
0x1F4A (8010)	0	R	Relative humidity PD conversion formula Intercept b	N	F32	-	Refer to Inclination and intercept to the unit specification
0x1F54 (8020)	0	R	Relative humidity peak value	N	S16	0x0000 (0)	Refer to process data for details
0x1F5E (8030)	0	0	Relative humidity bottom value	N	S16	0x03E8 (1000)	Refer to process data for details
0x2008 (8200)	0	R	Temperature PD conversion formula Inclination a	N	F32	-	Refer to Inclination and intercept to the unit specification
0x2012 (8210)	0	R	Temperature PD conversion formula Intercept b	N	F32	-	Refer to Inclination and intercept to the unit specification
0x201C (8220)	0	R	Temperature peak value	N	S16	0xFFCE (-50)	Refer to process data for details
0x2026 (8230)	0	R	Temperature bottom value	N	S16	0x0226 (550)	Refer to process data for details

\*1: "R" indicates Read and "W" indicates Write.

\*2: "Y" indicates that the parameter setting data is saved to the master, and "N" indicates that the parameter is not saved.

\*3: Refer to the table below for the symbols.

Symbol	Data type (IO-Link standard)	Data length Bit [byte]	Description
U8	UIntegerT	8[1]	Unsigned integer
U16		16[2]	
S16	IntegerT	16[2]	Signed integer
F32	Float32T	32[4]	Floating point number

[Selection of display items in standard setting]

Value	Setting details	Supplemental information	
0	Sub display measurement value display	Display the temperature value or relative humidity value.	
1	OUT1	When the value which does not match the OUT* output mode setting is written, acknowledgment is sent and [Std - -] is displayed.	
			Relative humidity HYS setting value
2			Relative humidity HYS hysteresis
3			Relative humidity Wind lower side set value
4			Relative humidity Wind upper side set value
5			Relative humidity Wind hysteresis
6			Temperature HYS set value
7			Temperature HYS hysteresis
8			Temperature Wind lower side set value
9			Temperature Wind upper side set value
10			Temperature Wind hysteresis
11			Error output
12	Output off		
13	OUT2	When the value which does not match the OUT* output mode setting is written, acknowledgment is sent and [Std - -] is displayed.	
			Relative humidity HYS set value
14			Relative humidity HYS hysteresis
15			Relative humidity Wind lower side set value
16			Relative humidity Wind upper side set value
17			Relative humidity Wind hysteresis
18			Temperature HYS set value
19			Temperature HYS hysteresis
20			Temperature Wind lower side set value
21			Temperature Wind upper side set value
22			Temperature Wind hysteresis
23			Error output
24	Output off		
25	Relative humidity bottom value		
26	Relative humidity peak value		
27	Temperature bottom value		
28	Temperature peak value		
29	SW output mode/communication mode display		

[Selection of display items in 2-value setting]

Value	Setting details	Selection of display items in 2-value setting		Supplemental information
		Left side	Right side	
0	Relative humidity value	<input type="radio"/>	<input type="radio"/>	
1	Temperature value	<input type="radio"/>	<input type="radio"/>	
2	Relative humidity OUT1 hysteresis mode set value	<input type="radio"/>	<input type="radio"/>	When relative humidity, hysteresis mode is selected
3	Relative humidity OUT1 hysteresis mode hysteresis	<input type="radio"/>	<input type="radio"/>	When relative humidity, hysteresis mode is selected
4	Relative humidity OUT1 window comparator mode set value (Lower side)	<input type="radio"/>	<input type="radio"/>	When relative humidity, window comparator mode is selected
5	Relative humidity OUT1 window comparator mode set value (Upper side)	<input type="radio"/>	<input type="radio"/>	When relative humidity, window comparator mode is selected
6	Relative humidity OUT1 window comparator mode hysteresis	<input type="radio"/>	<input type="radio"/>	When relative humidity, window comparator mode is selected
7	Relative humidity OUT2 hysteresis mode set value	<input type="radio"/>	<input type="radio"/>	When relative humidity, hysteresis mode is selected
8	Relative humidity OUT2 hysteresis mode hysteresis	<input type="radio"/>	<input type="radio"/>	When relative humidity, hysteresis mode is selected
9	Relative humidity OUT2 window comparator mode set value (Lower side)	<input type="radio"/>	<input type="radio"/>	When relative humidity, window comparator mode is selected
10	Relative humidity OUT2 window comparator mode set value (Upper side)	<input type="radio"/>	<input type="radio"/>	When relative humidity, window comparator mode is selected
11	Relative humidity OUT2 window comparator mode hysteresis	<input type="radio"/>	<input type="radio"/>	When relative humidity, window comparator mode is selected
12	Temperature OUT1 hysteresis mode set value	<input type="radio"/>	<input type="radio"/>	When temperature, hysteresis mode is selected
13	Temperature OUT1 hysteresis mode hysteresis	<input type="radio"/>	<input type="radio"/>	When temperature, hysteresis mode is selected
14	Temperature OUT1 window comparator mode set value (Lower side)	<input type="radio"/>	<input type="radio"/>	When temperature, window comparator mode is selected
15	Temperature OUT1 window comparator mode set value (Upper side)	<input type="radio"/>	<input type="radio"/>	When temperature, window comparator mode is selected
16	Temperature OUT1 window comparator mode hysteresis	<input type="radio"/>	<input type="radio"/>	When temperature, window comparator mode is selected
17	Temperature OUT2 hysteresis mode set value	<input type="radio"/>	<input type="radio"/>	When temperature, hysteresis mode is selected
18	Temperature OUT2 hysteresis mode hysteresis	<input type="radio"/>	<input type="radio"/>	When temperature, hysteresis mode is selected
19	Temperature OUT2 window comparator mode set value (Lower side)	<input type="radio"/>	<input type="radio"/>	When temperature, window comparator mode is selected
20	Temperature OUT2 window comparator mode set value (Upper side)	<input type="radio"/>	<input type="radio"/>	When temperature, window comparator mode is selected
21	Temperature OUT2 window comparator mode hysteresis	<input type="radio"/>	<input type="radio"/>	When temperature, window comparator mode is selected



Value	Setting details	Selection of display items in 2-value setting		Supplemental information
		Left side	Right side	
22	Relative humidity peak value	○	○	
23	Relative humidity bottom value	○	○	
24	Temperature peak value	○	○	
25	Temperature bottom value	○	○	
26	Display units	○	○	
27	OUT1 output mode/output type	○	×	
28	OUT2 output mode/output type	×	○	
29	NPN/PNP output setting	○	○	
30	Arbitrary character string	○	○	
31	Display OFF	○	○	

○: Settable    ×: Not settable (reject response)

	Default ↙	
Hexadecimal number	00 01 02 03 04 05 06 07 08 09 0A 0B 0C 0D 0E 0F	
Display character		
Hexadecimal number	10 11 12 13 14 15 16 17 18 19 1A 1B 1C 1D 1E 1F	
Display character		
Hexadecimal number	20 21 22 23 24 25 26 27 28 29 2A 2B 2C 2D 2E 2F	
Display character		

\*: When is written, a reject response will be sent

Line name communication data

## Maintenance

### **How to reset the product after a power loss or when the power has been unexpectedly cut off**

The settings of the product before power loss are retained in the product memory.

The output condition is also recoverable to that prior to the power loss. However, this may change depending on the operating environment. Therefore, check the safety of the whole system before operating the product.

Air should be run and warm-up (at least 15 min) before use.

Do not use organic solvents such as benzene, thinner or ethanol to clean the switch.

## Forgot the Security Code

If you have forgotten your security code, please contact SMC directly.

# Troubleshooting

## ○Troubleshooting

Applicable temperature & humidity switch: **PSH**

When any failure occurs with this product, the following chart can be used to identify the cause of the failure. If a cause applicable to the problems cannot be identified and normal operation is recovered by replacement with a new product, the product itself may be malfunctioning. The product may malfunction depending on the operating environment (network configuration, etc.). Please consult SMC for solutions.



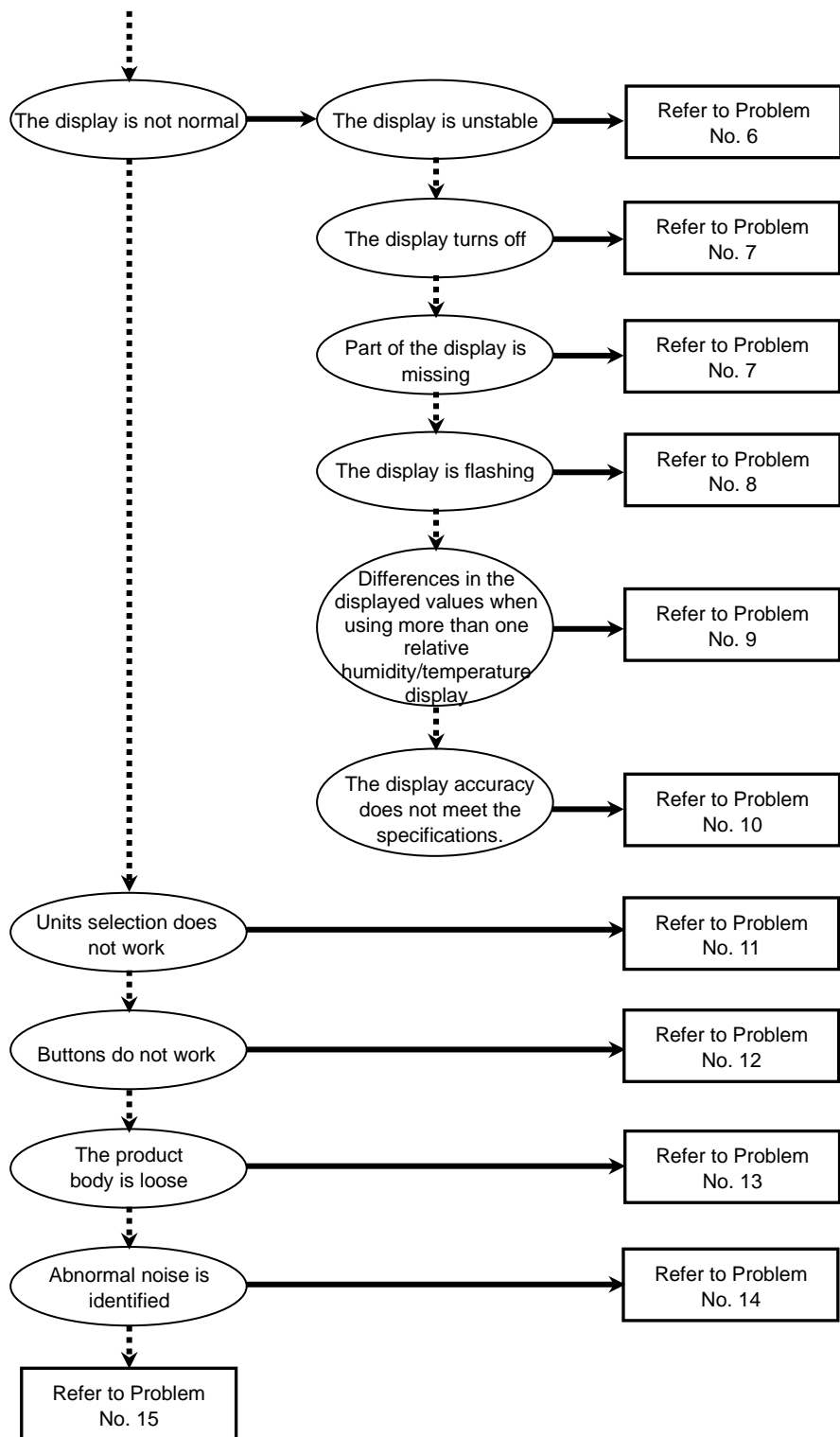

○Troubleshooting list

Problem No.	Phenomenon	Problem details Possible causes	Investigation method	Countermeasures
1	<ul style="list-style-type: none"> <li>•The output stays on The operation LED stays ON</li> <li>•The output stays off Operation LED stays OFF</li> </ul>	Incorrect relative humidity/temperature setting	(1) Check the relative humidity/temperature setting. (2) Check the settings of the operation mode, hysteresis, and output type. (Hysteresis mode/window comparator mode, normal output/reversed output)	(1) Set up the relative humidity/temperature again. (2) Set up the function again.
		Product failure		Replace the product.
2	The output stays on The operation LED functions normally	Incorrect wiring	Check the output wiring. Check that the load is not directly connected to DC(+) or DC(-).	Check and correct the wiring.
		Product failure		Replace the product.
3	The output stays off The operation LED functions normally	Incorrect wiring	Check the output wiring. Check that the load is not directly connected to DC(+) or DC(-).	Check and correct the wiring.
		SW output specification setting	Check the SW output specification setting. Check that the SW output is NPN as intended and not PNP and vice versa.	Set up the SW output specification again.
		Lead wire broken	Check if there is any bending stress applied to the lead wire. (Bending radius, tensile force to the lead wire)	Correct the wiring. (Reduce the tensile force or increase the bending radius)
		Product failure		Replace the product.
4	The switch output generates chattering.	Incorrect wiring	Check the wiring. Check if the brown and blue wires are connected to DC(+) and DC(-) respectively, and if the output line is secure (contact failure).	Rewire correctly.
		Relative humidity/temperature setting error	(1) Check the relative humidity/temperature setting. (2) Check if the hysteresis range is too small.	(1) Set up the relative humidity/temperature again. (2) Increase the hysteresis.
		Product failure		Replace the product.

Problem No.	Phenomenon	Problem details Possible causes	Investigation method	Countermeasures
5	<ul style="list-style-type: none"> <li>•Over current error (Er1, Er2) is displayed</li> <li>•System error (Er0, 4, 6, 8, 9, 40, 70, 71) is displayed</li> <li>•"HHH" is displayed</li> <li>•"LLL" is displayed</li> </ul>	Over current was applied to the output (Er1, Er2)	<ol style="list-style-type: none"> <li>(1) Check that the output current is not 10 mA or greater.</li> <li>(2) Check that the connected load complies with the specification. Check that the load is not short-circuited.</li> <li>(3) Check that a relay with surge protection is connected.</li> <li>(4) Check that the wiring is not in the same route as (or bundled together with) a high-voltage or power line.</li> </ol>	<ol style="list-style-type: none"> <li>(1), (2) Connect the load according to the specifications.</li> <li>(3) Use a relay with a surge voltage suppressor or take measures to prevent noise.</li> <li>(4) Separate the wiring from the high-voltage and/or power line.</li> </ol>
		Data inside the product was not processed correctly (Er0, 4, 6, 7, 8, 9, 40, 70,71)	<ol style="list-style-type: none"> <li>(1) Check that there is no possibility of noise interference (such as static electricity). Check that there is no noise source nearby.</li> <li>(2) Check that the power supply voltage is within the range of 18 to 30 VDC.</li> </ol>	<ol style="list-style-type: none"> <li>(1) Remove the noise and the noise source (or take measures to prevent noise interference) and reset the product, or turn off and on the power supply.</li> <li>(2) Supply power within the range of 18 to 30 VDC.</li> </ol>
		Applied temperature is higher than the upper limit (HHH)	<ol style="list-style-type: none"> <li>(1) Check that the temperature is not exceeding the upper limit of the set temperature range.</li> <li>(2) Check that no foreign matter has entered the piping.</li> </ol>	<ol style="list-style-type: none"> <li>(1) Reset applied temperature to a level within the set temperature range.</li> <li>(2) Take measures to prevent foreign matter from entering the piping.</li> </ol>
		Applied temperature is lower than the lower limit (LLL)	<ol style="list-style-type: none"> <li>(1) Check that the temperature is not exceeding the lower limit of the set temperature range.</li> <li>(2) Check that no foreign matter has entered the piping.</li> </ol>	<ol style="list-style-type: none"> <li>(1) Reset applied temperature to a level within the set temperature range.</li> <li>(2) Take measures to prevent foreign matter from entering the piping.</li> </ol>
		Product failure		Replace the product.

Problem No.	Phenomenon	Problem details Possible causes	Investigation method	Countermeasures
6	The display is unstable	Incorrect power supply	Check that the power supply voltage is within the range of 18 to 30 VDC.	Supply power within the range of 18 to 30 VDC.
		Incorrect wiring	Check the power supply wiring. Check if the brown and blue wires are connected to DC(+) and DC(-) respectively, and if the wiring is secure.	Check and correct the wiring.
		Supply pressure is not stable	Check if there is any fluctuation in the supply pressure.	If the fluctuation is not acceptable, the number of digits (display sensitivity) can be reduced by changing the display resolution. Furthermore, setting of the digital filter may improve the condition.
7	<ul style="list-style-type: none"> <li>•The display turns off</li> <li>•Part of the display is missing</li> </ul>	Incorrect power supply	Check that the power supply voltage is within the range of 18 to 30 VDC.	Supply power within the range of 18 to 30 VDC.
		Incorrect wiring	Check the power supply wiring. Check if the brown and blue wires are connected to DC(+) and DC(-) respectively, and if the wiring is secure.	Check and correct the wiring.
		Display off mode	Check that the display off mode is not selected.	Set up the function again.
		Product failure		Replace the product.
8	Display flashes	Incorrect wiring	(1) Check the power supply wiring. (2) Check if there is any bending stress applied to the lead wire.	(1) Check and correct the wiring. (2) Correct the wiring (bend radius and stress).
9	The relative humidity/temperature display is unstable when used in close proximity to each other	Variation within the accuracy range	Check that the variation is within the display accuracy range.	Use the fine adjustment mode to adjust the display if the variation is within the display accuracy range.
		Product failure		Replace the product.

Problem No.	Phenomenon	Problem details Possible causes	Investigation method	Countermeasures
10	Display accuracy does not meet the specifications	Product stored in an atmosphere with organic gas or high humidity	Check the storage condition.	Supply dry air and check that the product is within the accuracy range.
		Foreign matter entered the product	Check for any foreign matter entered or adhered to the piping port.	Use a 5 μm filter to prevent foreign matter from entering or sticking. Discharge the condensate of the filter periodically to prevent any accumulation.
		Air or liquid leakage	Check if any air or liquid is leaking from the piping.	Rework the piping. If the tightening torque is exceeded, the mounting screws, brackets, switches, etc. may be damaged.
		Insufficient warming	Check that the product satisfies the specified accuracy 15 minutes after supplying power.	After supplying power, the display and output can drift. For precise relative humidity/temperature detection, allow the product to warm up for 15 minutes or longer.
		Product failure		Replace the product.
11	The units cannot be selected	Model selection (A model without the units selection function has been selected)	Check that the product number printed on the product is equipped with units selection function.	Units selection function is not available for models only with SI units. *: The units selection function is not for use in Japan due to measurement law.
		Product failure		Replace the product.
12	Buttons do not work	Key-lock mode is activated	Check if the key-lock mode is turned on.	Deactivate key-lock mode.
		Product failure		Replace the product.
13	The product body is loose	Incorrect installation	Confirm that the product is properly secured to the panel mount adapter.	Mount the body on the panel securely.
		Product failure		Replace the product.
14	Abnormal noise is identified	Air or liquid leakage	Check if any air or liquid is leaking from the piping.	Rework the piping. If the tightening torque is exceeded, the mounting screws, brackets, switches, etc. may be damaged.
		Product failure		Replace the product.



Problem No.	Phenomenon	Problem details Possible causes	Investigation method	Countermeasures
15	The operation is unstable (Chattering)	Receiving the effect of fluctuation, etc. because hysteresis is too narrow.	Check the relative humidity and temperature (hysteresis).	Check the relative humidity and temperature setting.
		Incorrect wiring/Breakage of lead wire	(1) Check the power supply wiring. (2) Check if there is any bending stress applied to the lead wire. (Bending radius, tensile force applied to the lead wire)	(1) Check and correct the wiring. (2) Correct the wiring. (Reduce the tensile force or increase the bending radius)
		Product failure		Replace the product.

○Troubleshooting (IO-Link communication function)

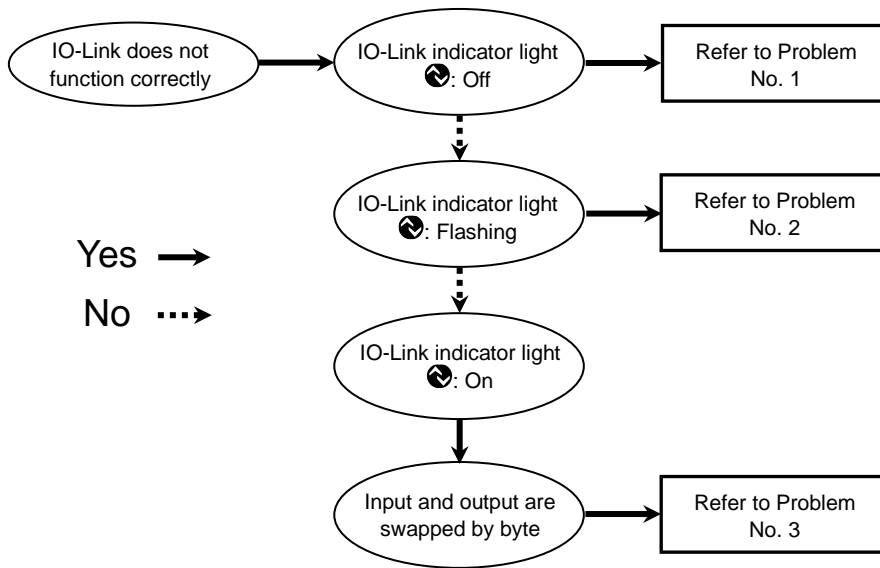



○ Troubleshooting list (IO-Link communication function)

Problem No.	Phenomenon	Description	Problem details Possible causes	Investigation method	Countermeasures
		1	IO-Link indicator light 🔴: Off	-	Incorrect connector wiring  Power supply error from the IO-Link master
2	IO-Link indicator light 🔴: Flashing	node ***	Communication is not established IO-Link wiring failure	Check the connection and cable condition of the IO-Link cable.	Additionally, tighten the IO-Link cable (Replace the cable if it is broken).
		Er 5 u IO	Master and product version are not matched.	Check the IO-Link version of the master and device.	Match the master IO-Link version to the device. *1
		node Start  node Pre	The communication mode is not transferred to the Operation mode.	Check the setting of the data storage access lock and data storage backup level of the master.	Release the data storage access lock. Or deactivate the setting of the data storage backup level of the master port.
		node Loc	Backup and restore request during data storage lock	Check the data storage lock.	Release the data storage lock.
3	Data is swapped by byte.	-	Program data assignment is incorrect.	Check whether the Endian type on the master upper level communication transmission format is Big-Endian type or Little-Endian type.	Assign the program data based on the Endian type of the transmission format of the master upper level communication. Or set the master byte swap setting. (Refer to page 73 for the Endian type of the upper level communication.)

\*1: An error will be displayed when the product is connected to the IO-Link master version "V1.0."

○ Error display function

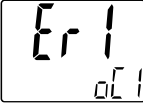
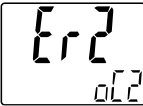
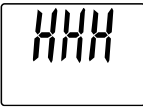
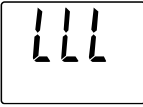
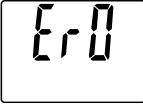
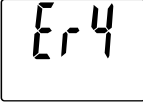
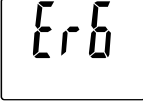
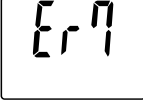
This function is to display the error location and content when a problem or error has occurred.

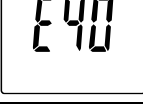
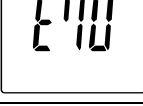
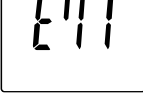
Error name	Error indication	Details	Measures	Error output
Over current error	 *2	The load current applied to the switch output has exceeded the maximum value.	Turn the power off and remove the cause of the over current. Then supply the power again.	○
	 *2			
Temperature error		Temperature exceeding the upper limit of the set temperature range is applied.	Reset applied temperature to a level within the set temperature range.	Not applicable
		Temperature below the lower limit of the set temperature range is applied.		Not applicable
System error	 *1	Displayed if an internal data error has occurred.	Turn the power off and on again. If the product cannot be reset, contact SMC for further investigation.	Not applicable
	 *1			Not applicable
	 *1			○
	 *1			Not applicable
	 *1			○
	 *1			○
	 *1			Not applicable
	 *1			Not applicable
				Not applicable

Error name	Error indication	Details	Measures	Error output
Version does not match		IO-Link version does not match with the master. Mismatch because the master version is 1.0.	Match the master IO-Link version to the device.	○

\*1: The switch output will be OFF when an error is generated.

An error is output when the error output is set (in the product with error output function).

\*2: When the set output is an over current error when the error output is set, the switch output is OFF.

If the error cannot be reset after the above measures are taken, or errors other than above are displayed, please contact SMC.

### Setting of the error output

In reversed output mode, error [Er0], [Er4], [Er7] and [Er40] can be detected.

Normal output

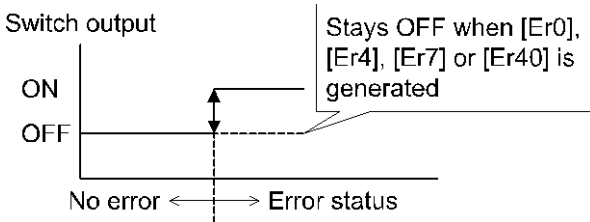

Reversed output

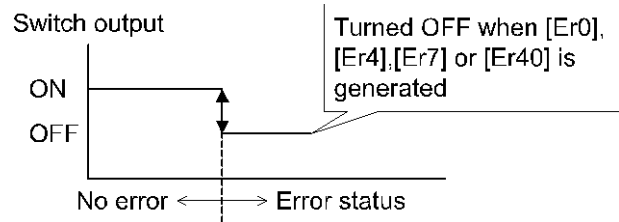

# Specification

Model		PSH		
Applicable fluid		Air, Non-corrosive gas JISB8392-1 1.1.2 to 1.6.2 ISO8573-1 1.1.2 to 1.6.2		
Temperature	Rated temperature range		0 to 50 °C	
	Display and set temperature range		-5 to 55 °C	
	Display and smallest settable increment		0.1 °C	
Relative humidity	Display and set relative humidity range		0 to 100%R.H. (No condensation)	
	Display and smallest settable increment		0.1%R.H.	
Pressure	Rated pressure range *1		0.3 to 1 MPa	
	Operating pressure range		0.1 to 1 MPa	
Flow rate consumption		5 L/min (Pressure: 1 MPa)		
Power supply	Power supply voltage		18 to 30 VDC (Including ripple)	
	Current consumption		35 mA or less	
	Protection		Polarity protection	
Accuracy *2	Temperature	Display accuracy	±3 °C±1 digit	
		Analogue output accuracy *3	±3.5 °C	
	Relative humidity	Display accuracy	±5%R.H.±1 digit	
		Analogue output accuracy *3	±5.5%R.H.	
Switch output	Output type		Select from NPN/PNP open collector output	
	Output mode		Hysteresis mode, Window comparator mode, Error output, Output off mode	
	Switch operation		Normal output, Reversed output	
	Maximum load current		10 mA	
	Maximum applied voltage (NPN only)		30 V	
	Internal voltage drop (Residual voltage)		1.5 V or less (at 10 mA load current)	
	Hysteresis	Hysteresis mode		Variable from 0
		Window comparator mode		
Short circuit protection		Provided		
Analogue output	Output type		1-5 V *4	
	Output impedance		Approx. 1 kΩ	
Digital filter *5		0.0 to 60.00 s (0.01 increments)		

Model		PSH
Display	Unit	°C, °F, %R.H.
	Display type	LCD
	Number of displays	3-screen display (Main display, sub display x 2)
	Display colour	1) Main display: White/Red 2) Sub display: Orange
	Number of display digits	1) Main display: 3 1/2-digits, 7-segments 2) Sub display: 4-digits, 7-segments
	Operation light	LED is ON when switch output is ON (OUT1, OUT2: Orange)
Environmental resistance	Enclosure	IP65
	Withstand voltage	1000 VAC for 1 minute between terminals and housing
	Insulation resistance	50 MΩ or more between terminals and housing (with 500 VDC megameter)
	Ambient temperature range	Operation: 0 to 50 °C, Storage: -10 to 60 °C (No condensation or freezing)
	Ambient humidity range *6	Operation, storage: 35 to 85%R.H. (No condensation)
Standards		CE/UKCA marked (EMC directive, RoHS directive)
Length of lead wire with connector		2 m

\*1: This is the accuracy relative to atmospheric pressure and relative humidity when used within the rated pressure range.

\*2: This is the overall accuracy, including the effects of factors such as temperature and repetition.

\*3: For analogue output, select relative humidity/temperature according to the setting.

\*4: Relative humidity: 1 to 5 V at 0 to 100%R.H. and temperature: 1 to 5 V at 0 to 50 °C.

\*5: Time for 90% response to step input in internal sensor signals.

\*6: Do not store in closed conditions without air exchange conditions.

\*7: If the piping contains gases such as oil mist or organic solvents, it may not meet the specified accuracy or may cause malfunction.

\*8: Products with tiny scratches, marks, or display colour or brightness variations which do not affect the performance of the product are verified as conforming products.

○Piping specification and weight

Model		PSH
Port size		R1/8
Main materials in contact with fluid	Sensor unit	Silicon, etc.
	Piping port	SUS303, CAC403, C3604 (Electroless nickel plating), ZDC2 (Nickel plating), Glass-cloth epoxy resin O-ring: EPDM, FKM
Weight	Body	103 g
	Lead wire with connector	+39 g

○Cable specification

Conductor cross-sectional area		0.15 mm <sup>2</sup> (AWG26)
Insulator	Outside diameter	1.0 mm
	Colours	Brown, blue, black, white, grey (5 core)
Sheath	Wire outside diameter	φ3.5

○Communication specification (For IO-Link compatible products)

IO-Link type	Device
IO-Link version	V1.1
Communication speed	COM2 (38.4 kbps)
Setting file	IODD file *9
Minimum cycle time	3.8 ms
Process data length	Input Data: 6 byte, Output Data: 0 byte
On-request data communication	Supported
Data storage function	Supported
Event function	Supported
Vendor ID	131 (0x0083)
Device ID	PSH-L2(-M)-*: 650 (0x00028A)

\*9: The configuration file can be downloaded from the SMC website. <https://www.smcworld.com>



## ■Dimensions

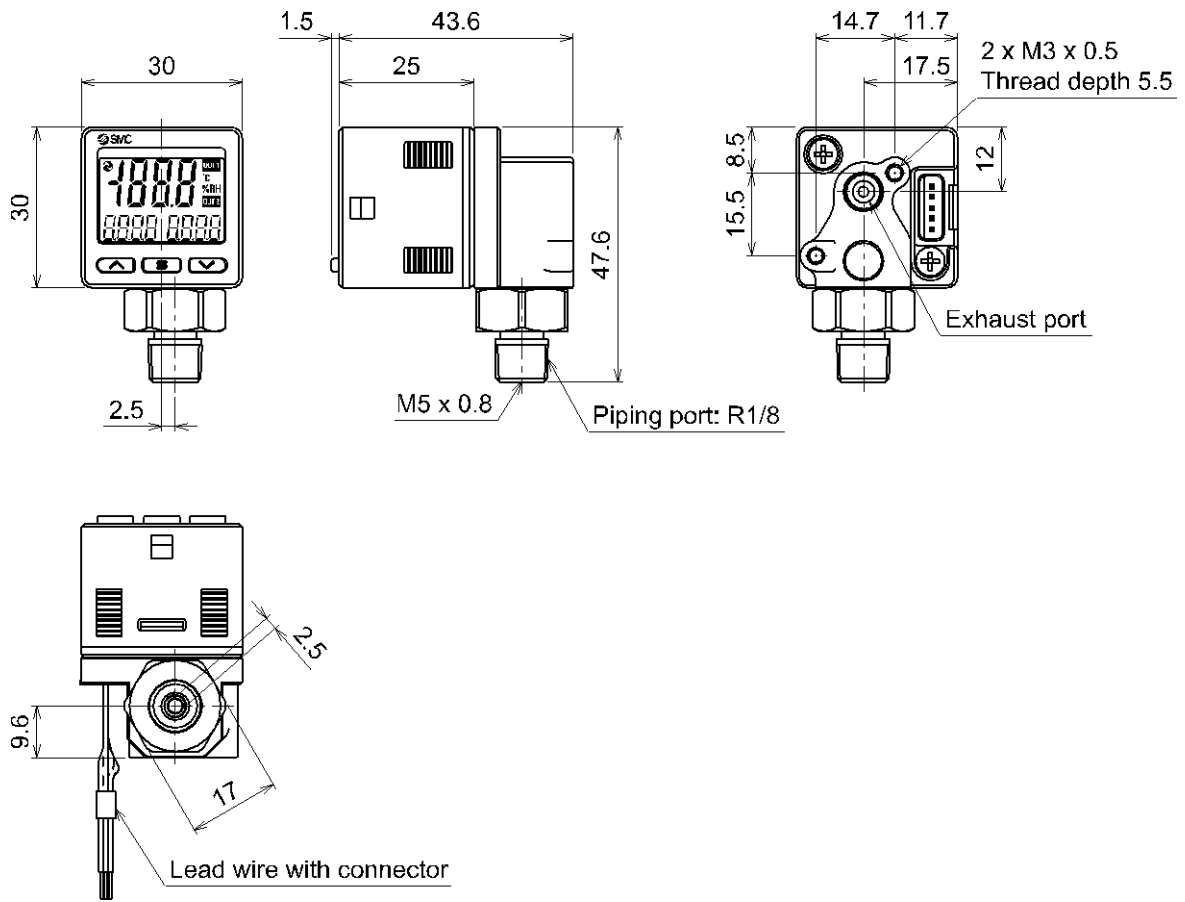

○Bracket mounting dimensions

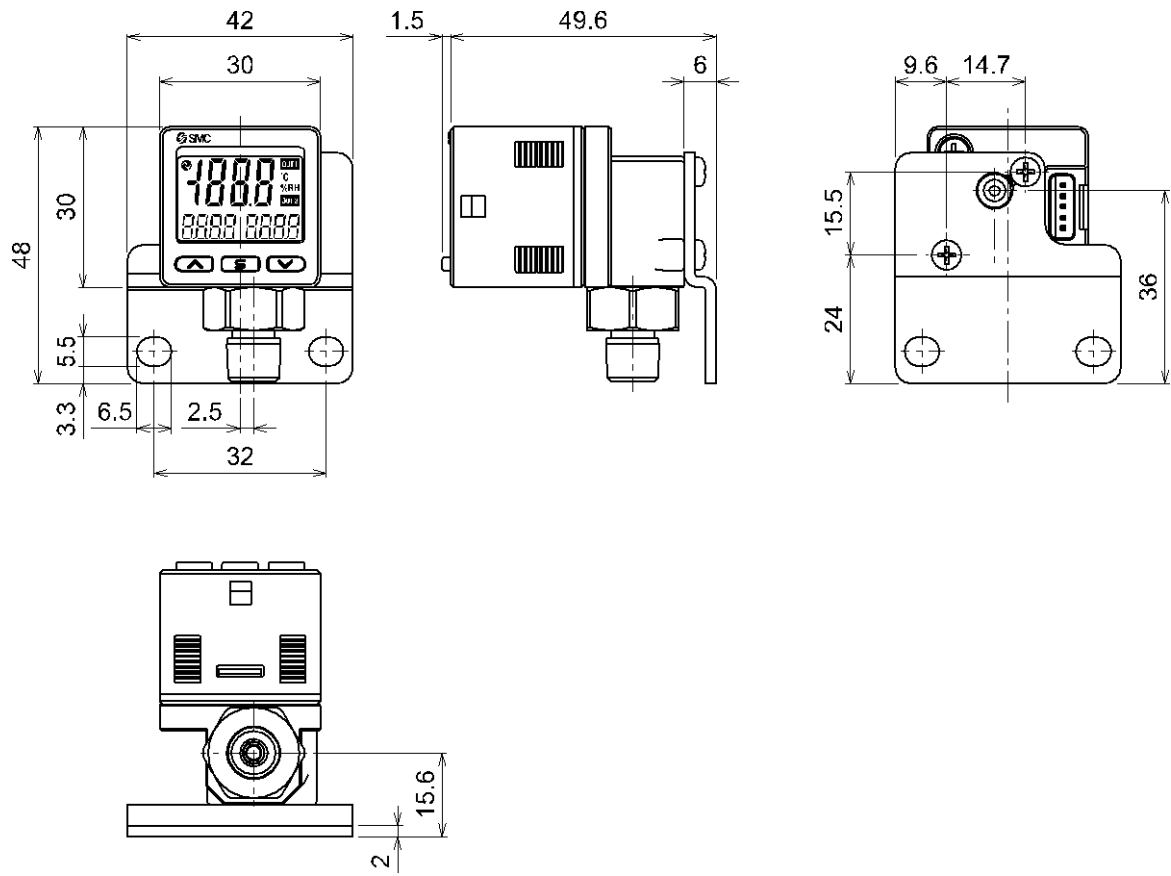

○Mounting dimensions of panel mount adapter

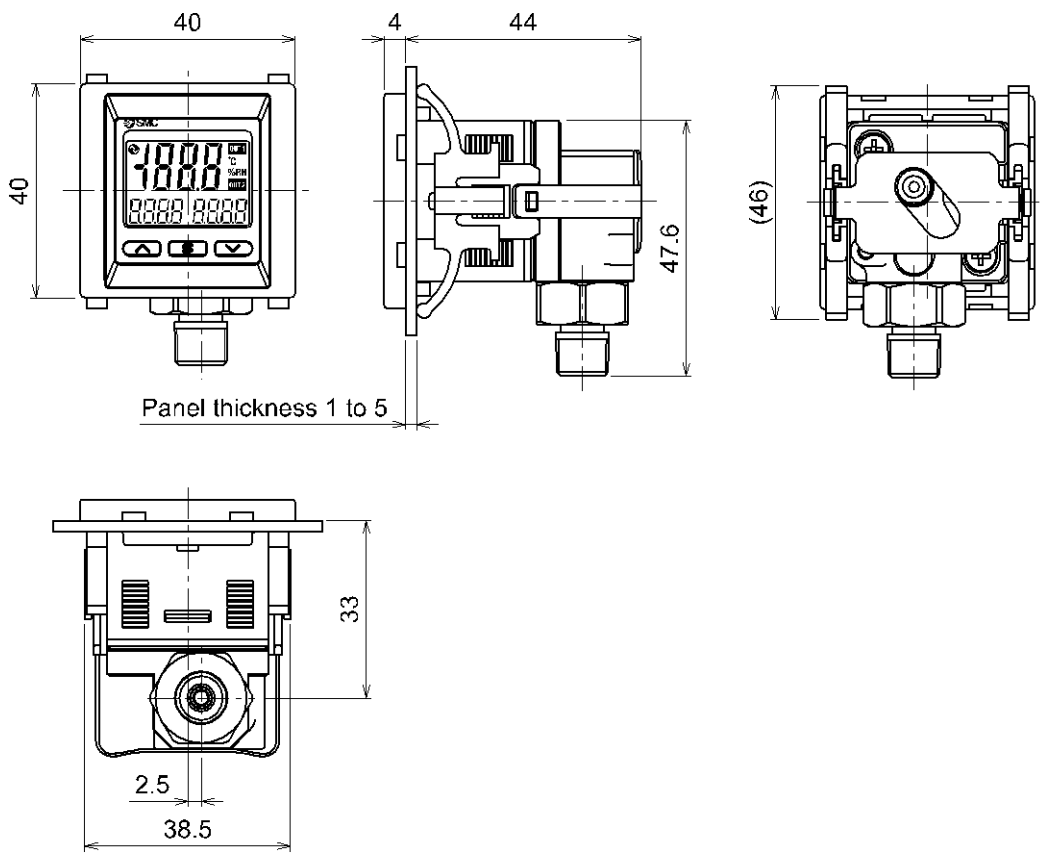

○Mounting dimension of panel mount adapter + Front protective cover

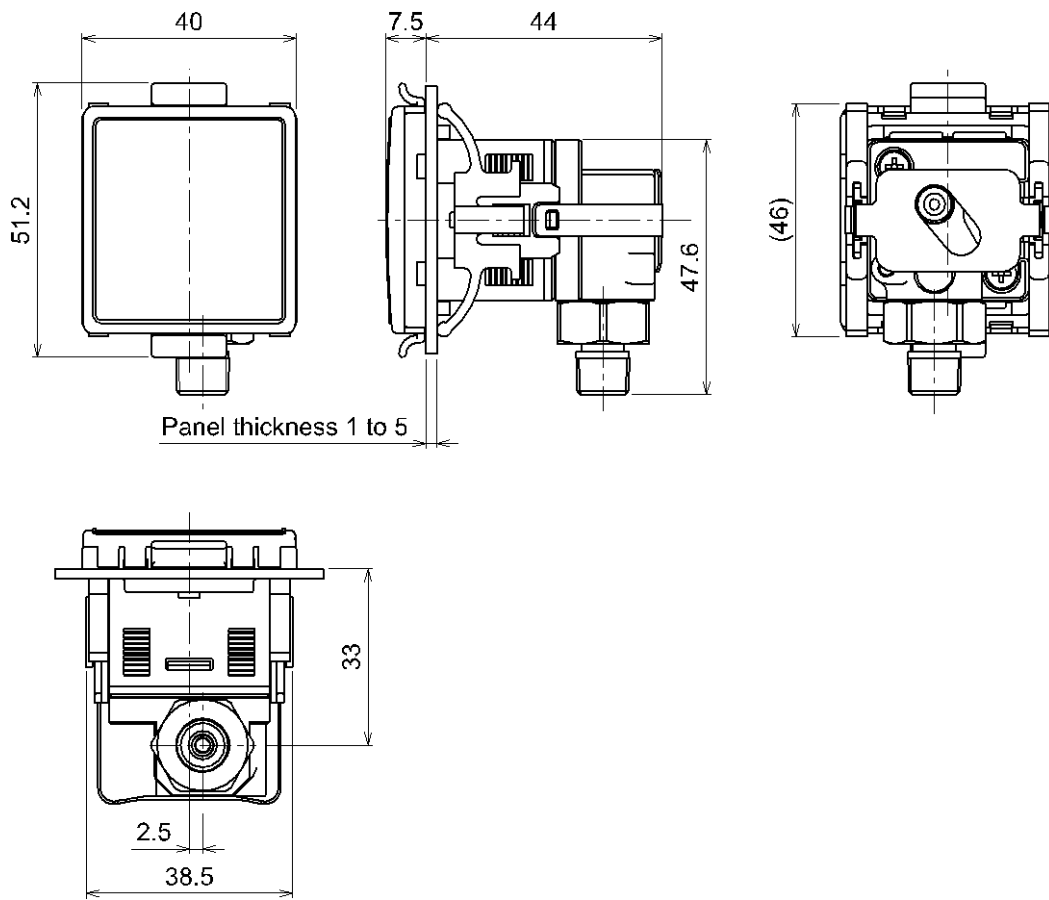

○ Panel cutout dimensions

Individual mounting

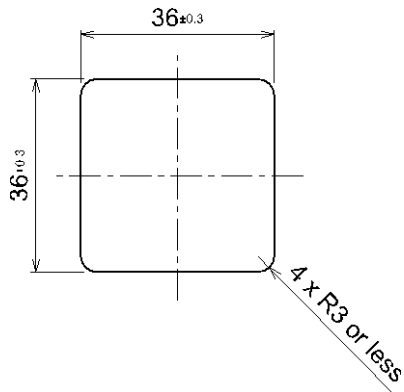

More than 2 pcs. (n pcs.) close mounting

<Horizontal>

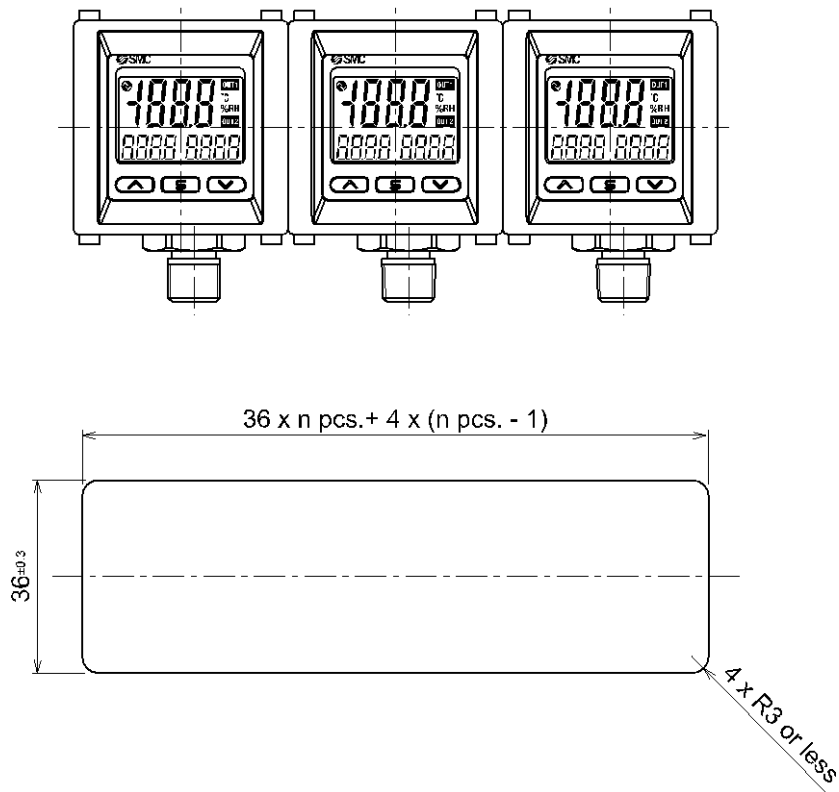

○Lead wire with connector (part number: ZS-46-5F)

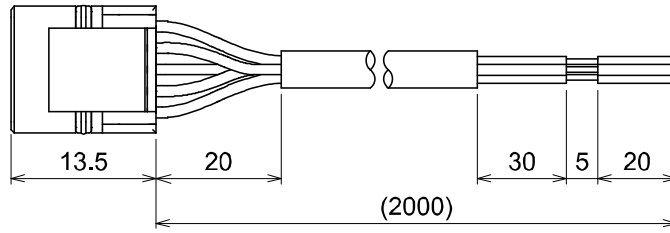

Revision history

# SMC Corporation

4-14-1, Sotokanda, Chiyoda-ku, Tokyo 101-0021 JAPAN

Tel: + 81 3 5207 8249 Fax: +81 3 5298 5362

URL <https://www.smcworld.com>

---

Note: Specifications are subject to change without prior notice and any obligation on the part of the manufacturer.  
© SMC Corporation All Rights Reserved

