



Operation Manual

PRODUCT NAME

Pressure Switch
( IO-Link compatible)

MODEL / Series / Product Number

PSE54#-L/N/P

SMC Corporation

Table of Contents

Safety Instructions	3
Model Indication and How to Order	9
Definition and terminology	12
Mounting and Installation	16
Wiring	16
Pressure Setting	17
IO-Link Specifications	18
Outline of IO-Link functions	18
Communication specifications	18
Process data	19
IO-Link parameter setting	22
Maintenance	32
Troubleshooting	33
Specification	39
Dimensions	42



Safety Instructions

These safety instructions are intended to prevent hazardous situations and/or equipment damage. These instructions indicate the level of potential hazard with the labels of “**Caution**,” “**Warning**” or “**Danger**.” They are all important notes for safety and must be followed in addition to International Standards (ISO/IEC)^{*)}, and other safety regulations.

*1) ISO 4414: Pneumatic fluid power - General rules and safety requirements for systems and their components
ISO 4413: Hydraulic fluid power - General rules and safety requirements for systems and their components
IEC 60204-1: Safety of machinery - Electrical equipment of machines - Part 1: General requirements
ISO 10218-1: Robots and robotic devices - Safety requirements for industrial robots - Part 1: Robots
etc.



Danger

Danger indicates a hazard with a high level of risk which, if not avoided, will result in death or serious injury.



Warning

Warning indicates a hazard with a medium level of risk which, if not avoided, could result in death or serious injury.



Caution

Caution indicates a hazard with a low level of risk which, if not avoided, could result in minor or moderate injury.

Warning

1. The compatibility of the product is the responsibility of the person who designs the equipment or decides its specifications.

Since the product specified here is used under various operating conditions, its compatibility with specific equipment must be decided by the person who designs the equipment or decides its specifications based on necessary analysis and test results. The expected performance and safety assurance of the equipment will be the responsibility of the person who has determined its compatibility with the product. This person should also continuously review all specifications of the product referring to its latest catalog information, with a view to giving due consideration to any possibility of equipment failure when configuring the equipment.

2. Only personnel with appropriate training should operate machinery and equipment.

The product specified here may become unsafe if handled incorrectly. The assembly, operation and maintenance of machines or equipment including our products must be performed by an operator who is appropriately trained and experienced.

3. Do not service or attempt to remove product and machinery/equipment until safety is confirmed.

1. The inspection and maintenance of machinery/equipment should only be performed after measures to prevent falling or runaway of the driven objects have been confirmed.
2. When the product is to be removed, confirm that the safety measures as mentioned above are implemented and the power from any appropriate source is cut, and read and understand the specific product precautions of all relevant products carefully.
3. Before machinery/equipment is restarted, take measures to prevent unexpected operation and malfunction.

4. Our products cannot be used beyond their specifications. Our products are not developed, designed, and manufactured to be used under the following conditions or environments. Use under such conditions or environments is not covered.

1. Conditions and environments outside of the given specifications, or use outdoors or in a place exposed to direct sunlight.
2. Use for nuclear power, railways, aviation, space equipment, ships, vehicles, military application, equipment affecting human life, body, and property, fuel equipment, entertainment equipment, emergency shut-off circuits, press clutches, brake circuits, safety equipment, etc., and use for applications that do not conform to standard specifications such as catalogs and operation manuals.
3. Use for interlock circuits, except for use with double interlock such as installing a mechanical protection function in case of failure. Please periodically inspect the product to confirm that the product is operating properly.



Safety Instructions

Caution

We develop, design, and manufacture our products to be used for automatic control equipment, and provide them for peaceful use in manufacturing industries.

Use in non-manufacturing industries is not covered.

Products we manufacture and sell cannot be used for the purpose of transactions or certification specified in the Measurement Act.

The new Measurement Act prohibits use of any unit other than SI units in Japan.

Limited warranty and Disclaimer/Compliance Requirements

The product used is subject to the following “Limited warranty and Disclaimer” and “Compliance Requirements”.

Read and accept them before using the product.

Limited warranty and Disclaimer

1. The warranty period of the product is 1 year in service or 1.5 years after the product is delivered, whichever is first.*2)

Also, the product may have specified durability, running distance or replacement parts. Please consult your nearest sales branch.

2. For any failure or damage reported within the warranty period which is clearly our responsibility, a replacement product or necessary parts will be provided.

This limited warranty applies only to our product independently, and not to any other damage incurred due to the failure of the product.

3. Prior to using SMC products, please read and understand the warranty terms and disclaimers noted in the specified catalog for the particular products.

***2) Vacuum pads are excluded from this 1 year warranty.**

A vacuum pad is a consumable part, so it is warranted for a year after it is delivered.

Also, even within the warranty period, the wear of a product due to the use of the vacuum pad or failure due to the deterioration of rubber material are not covered by the limited warranty

Compliance Requirements

1. The use of SMC products with production equipment for the manufacture of weapons of mass destruction (WMD) or any other weapon is strictly prohibited.

2. The exports of SMC products or technology from one country to another are governed by the relevant security laws and regulations of the countries involved in the transaction. Prior to the shipment of a SMC product to another country, assure that all local rules governing that export are known and followed.

Operator

- ◆ This operation manual is intended for those who have knowledge of machinery using pneumatic equipment, and have sufficient knowledge of assembly, operation and maintenance of such equipment. Only those persons are allowed to perform assembly, operation and maintenance.
- ◆ Read and understand this operation manual carefully before assembling, operating or providing maintenance to the product.

■ Safety Instructions

Warning

- Do not disassemble, modify (including changing the printed circuit board) or repair.
An injury or failure can result.
- Do not operate the product outside of the specifications.
Do not use for flammable or harmful fluids.
Fire, malfunction, or damage to the product can result.
Verify the specifications before use.
- Do not operate in an atmosphere containing flammable or explosive gases.
Fire or an explosion can result.
This product is not designed to be explosion proof.
- Do not use the product in a place where static electricity is a problem.
Otherwise it can cause failure or malfunction of the system.
- If using the product in an interlocking circuit:
 - Provide a double interlocking system, for example a mechanical system
 - Check the product regularly for proper operationOtherwise malfunction can result, causing an accident.
- The following instructions must be followed during maintenance:
 - Turn off the power supply
 - Stop the air supply, exhaust the residual pressure and verify that the air is released before performing maintenanceOtherwise an injury can result.

Caution

- Do not touch the terminals and connectors while the power is on.
Otherwise electric shock, malfunction or damage to the product can result.
- After maintenance is complete, perform appropriate functional inspections and leak tests.
Stop operation if the equipment does not function properly or there is a leakage of fluid.
When leakage occurs from parts other than the piping, the product might be faulty.
Disconnect the power supply and stop the fluid supply.
Do not apply fluid under leaking conditions.
Safety cannot be assured in the case of unexpected malfunction.

■ NOTE

- Follow the instructions given below when designing, selecting and handling the product.
- The instructions on design and selection (installation, wiring, environment, adjustment, operation, maintenance, etc.) described below must also be followed.
- *Product specifications
 - The direct current power supply to combine should be UL approved as follows.
Circuit (of Class2) which is of maximum 30 Vrms (42.4 V peak) or less, with UL1310 Class2 power supply unit or UL1585 Class2 transformer.
 - The Pressure Switch is a UL approved product only if it has a  mark on the body.
 - Use the specified voltage.
Otherwise failure or malfunction can result.
 - Do not exceed the specified maximum allowable load.
Otherwise it can cause damage or shorten the lifetime of the pressure switch.
 - Design the product to prevent reverse current when the circuit is opened or the product is forced to operate for operational check.
Reverse current can cause malfunction or damage to the product.
 - Input data to the pressure switch is not deleted, even if the power supply is cut off.
(Writing time: 10,000 times, Data duration: 20 years after power off)
 - For the details of compressed air quality, refer to ISO 8573-1, 1.1.2 to 1.6.2: 2001.
This can cause operating failure.
If compressed air containing condensate is used, install an air dryer or drain catch before the filter and perform drainage regularly.
If drainage is not performed regularly and condensate enters the secondary side, it can cause operating failure of pneumatic equipment.
If regular drainage is difficult, the use of a filter with an auto drain is recommended.
 - Applicable fluid is air, inert gases and incombustible gases.
Do not use a fluid containing chemicals, synthetic oils including organic solvent, salt and corrosive gases.
Otherwise, damage to the product and malfunction can result.
Check the details of the specifications before using.
 - Use the specified measurement flow rate and operating pressure.
Otherwise it can cause damage to the Pressure Switch or inability to measure correctly.
 - Reserve a space for maintenance.
Allow sufficient space for maintenance when designing the system.

● Product handling

*Installation

- Tighten to the specified tightening torque.
If the tightening torque is exceeded the mounting screws and brackets may be broken.
If the tightening torque is insufficient, the product can be displaced and loosen the mounting screws.
- Be sure to ground terminal FG when using a commercially available switch-mode power supply.
- Do not drop, hit or apply shock to the Pressure Switch.
Otherwise damage to the internal parts can result, causing malfunction.
- Do not pull the lead wire forcefully, not lift the product by pulling the lead wire. (Tensile force 50N or less)
Hold the body when handling to avoid the damage of the Pressure Switch lead to cause the failure and malfunction.
- For piping of the Pressure Switch, hold the piping with a spanner on the metal part of the piping (Piping attachment).
Holding other part with spanner leads to damage the Pressure Switch.
- Eliminate any dust left in the piping by air blow before connecting the piping to the product.
Otherwise it can cause damage or malfunction.
- Do not insert metal wires or other foreign matter into the pressure measurement port.
It can damage the Pressure Switch causing failure or malfunction.
- If the entering of foreign material to the fluid is possible, install and pipe the filter or the mist separator to the inlet to avoid failure and malfunction.

*Wiring

- Do not pull the lead wires.
In particular, never lift a Pressure Switch equipped with fitting and piping by holding the lead wires.
- Avoid repeatedly bending or stretching the lead wire, or placing heavy load on them.
Repetitive bending stress or tensile stress can cause the sheath of the wire to peel off, or breakage of the wire.
If the lead wire can move, fix it near the body of the product.
The recommended bend radius of the lead wire is 6 times the outside diameter of the sheath, or 33 times the outside diameter of the insulation material, whichever is larger.
Replace the damaged lead wire with a new one.
- Wire correctly.
Incorrect wiring can break the Pressure Switch.
- Do not perform wiring while the power is on.
Otherwise damage to the internal parts can result, causing malfunction.
- Do not route wires and cables together with power or high voltage cables.
Otherwise the product can malfunction due to interference of noise and surge voltage from power and high voltage cables to the signal line. Route the wires (piping) of the product separately from power or high voltage cables.
- Confirm proper insulation of wiring.
Poor insulation (interference from another circuit, poor insulation between terminals, etc.) can lead to excess voltage or current being applied to the product, causing damage.
- Keep wiring as short as possible to prevent interference from electromagnetic noise and surge voltage.
Do not use a cable longer than 20 m.
Wire the DC(-) line(blue) as close as possible to the power supply.

*Environment

- Do not use the product in area that is exposed to corrosive gases, chemicals, sea water, water or steam. Otherwise failure or malfunction can result.
- Do not use in a place where the product could be splashed by oil or chemicals.
If the product is to be used in an environment containing oils or chemicals such as coolant or cleaning solvent, even for a short time, it may be adversely affected (damage, malfunction, or hardening of the lead wires).
- Do not use in an area where surges are generated.
If there is equipment which generates a large amount of surge (solenoid type lifter, high frequency induction furnace, motor, etc.) close to the Pressure Switch, this may cause deterioration or breakage of the internal circuit of the Pressure Switch. Avoid sources of surge generation and crossed lines.
- The product is CE/UKCA marked, but not immune to lightning strikes. Take measures against lightning strikes in the system.
- Mount the product in a place that is not exposed to vibration or impact.
Otherwise failure or malfunction can result.
- Prevent foreign matter such as remnant of wires from entering the Pressure Switch.
Take proper measures for the remnant not to enter the Pressure Switch in order to prevent failure or malfunction.
- Do not use the product in an environment that is exposed to temperature cycle.
Heat cycles other than ordinary changes in temperature can adversely affect the inside of the product.
- Do not expose the product to direct sunlight.
If using in a location directly exposed to sunlight, shade the product from the sunlight.
Otherwise failure or malfunction can result.
- Keep within the specified fluid and ambient temperatures range.
The fluid and ambient temperatures should be 0 to 50 °C. Operation under low temperature leads to cause damage or operation failure due to frozen moist in the fluid or air.
Protection against freezing is necessary. Air dryer is recommended for elimination of drain and water.
Avoid sudden temperature change even within specified temperature.
- Do not operate close to a heat source, or in a location exposed to radiant heat.
Otherwise malfunction can result.

*Adjustment and Operation

- Turn the power on after connecting a load.
Otherwise it can cause excess current causing instantaneous breakage of the pressure switch.
- Do not short-circuit the load.
Although error is displayed when the pressure switch load is short circuit, generated excess current lead to cause the damage of the pressure switch.
- If using the product to detect very small pressure rates, warm up the product for 20 to 30 minutes first.
There will be a drift on the display of approximate $\pm 1\%$ immediately after the power supply is turned on, within 10 minutes.
- Perform settings suitable for the operating conditions.
Incorrect setting can cause operation failure.
For details of each setting, refer to page [16](#) to [29](#) of this manual.

*Maintenance

- Turn off the power supply, stop the supplied air, exhaust the residual pressure and verify the release of air before performing maintenance.
There is a risk of unexpected malfunction.
- Perform regular maintenance and inspections.
There is a risk of unexpected malfunction.
- Perform drainage regularly.
If condensate enters the secondary side, it can cause operating failure of pneumatic equipment.
- Do not use solvents such as benzene, thinner etc. to clean the Pressure Switch.
They could damage the surface of the body and erase the markings on the body.
Use a soft cloth to remove stains. For heavy stains, use a cloth soaked with diluted neutral detergent and fully squeezed, then wipe up the stains again with a dry cloth.

Model Indication and How to Order

PSE54 **1** **□** - **M3** - **L** **□**

Sensor range

Symbol	Content
0	Positive pressure (0 to 1 MPa)
1	Vacuum pressure (0 to -101 kPa)
3	Compound pressure (-100 to 100 kPa)

Accuracy

Symbol	Content
Nil	±2%F.S.
A	±1%F.S.

Lead wire termination

Symbol	Content
Nil	Half strip, 3000 mm
S	With M12-4 pin connector, 500 mm

Output specification

Symbol	Content
L	IO-Link/Switch 1 output (Switch output is NPN or PNP switching type)
N	NPN open collector 1 output
P	PNP open collector 1 output

Port size

Symbol	Content
M3	M3 x 0.5
M5	M5 x 0.8
01	R1/8 (with M5 female thread)
N01	NPT1/8 (with M5 female thread)
R04	φ 4 reducer
R06	φ 6 reducer
IM5	M5 female thread, through type
IM5H	M5 female thread, through type (with setting hole)

Output specification N/P

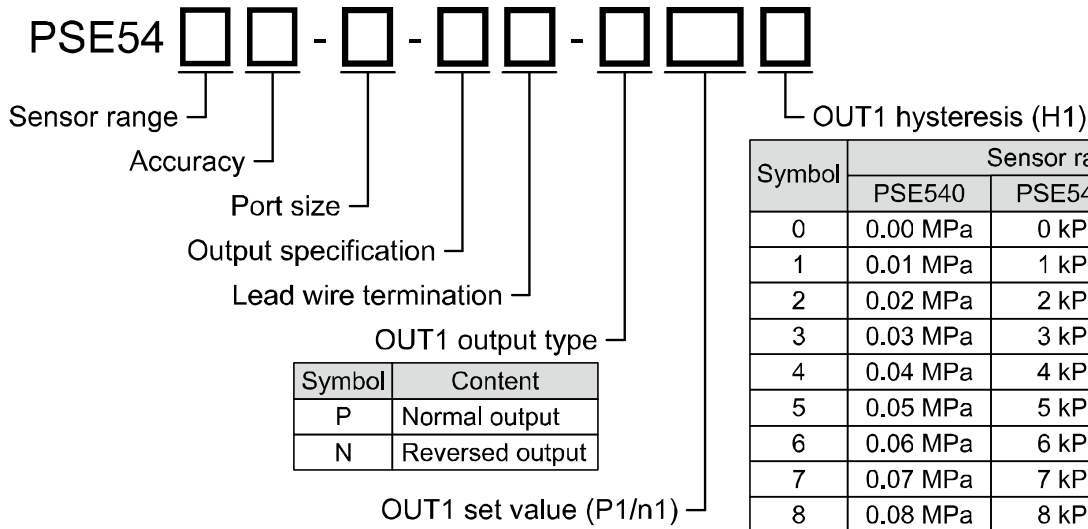

Symbol	Content
P	Normal output
N	Reversed output

Symbol	Sensor range		
	PSE540	PSE541	PSE543
0	0.00 MPa	0 kPa	0 kPa
1	0.01 MPa	1 kPa	1 kPa
2	0.02 MPa	2 kPa	2 kPa
3	0.03 MPa	3 kPa	3 kPa
4	0.04 MPa	4 kPa	4 kPa
5	0.05 MPa	5 kPa	5 kPa
6	0.06 MPa	6 kPa	6 kPa
7	0.07 MPa	7 kPa	7 kPa
8	0.08 MPa	8 kPa	8 kPa
9	0.09 MPa	9 kPa	9 kPa
A	0.10 MPa	10 kPa	10 kPa

Symbol	Sensor range		
	PSE540	PSE541	PSE543
-10			-100 kPa *1
-09			-90 kPa
-08			-80 kPa
-07			-70 kPa
-06			-60 kPa
-05			-50 kPa
-04			-40 kPa
-03			-30 kPa
-02			-20 kPa
-01	-0.1 MPa *1	10 kPa *1	-10 kPa
000	0.0 MPa	0 kPa	0 kPa
001	0.1 MPa	-10 kPa	10 kPa
002	0.2 MPa	-20 kPa	20 kPa
003	0.3 MPa	-30 kPa	30 kPa
004	0.4 MPa	-40 kPa	40 kPa
005	0.5 MPa	-50 kPa	50 kPa
006	0.6 MPa	-60 kPa	60 kPa
007	0.7 MPa	-70 kPa	70 kPa
008	0.8 MPa	-80 kPa	80 kPa
009	0.9 MPa	-90 kPa	90 kPa
010	1.0 MPa *1	-100 kPa *1	100 kPa *1

*1: Part numbers whose switch output switching point is out of the set pressure range cannot be selected.

Normal output: $P1 - H1 \geq$ set pressure range lower limit (PSE540, PSE543)

$P1 + H1 \geq$ set pressure range lower limit (PSE541)

Reversed output: $n1 + H1 \leq$ set pressure range upper limit (PSE540, PSE543)

$n1 - H1 \leq$ set pressure range upper limit (PSE541)

Be sure to confirm the above.

*2: If you wish to use a set value other than the above, contact your local SMC sales representative.

Normal output

Switch output

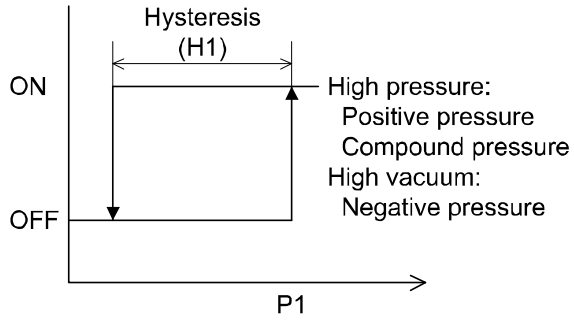

Reversed output

Switch output

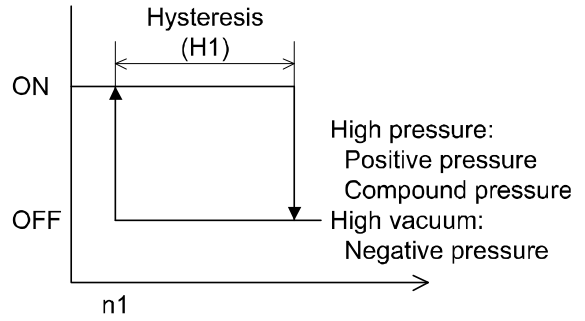

■ Definition and terminology

	Term	Definition
A	Analog output function	Function to output the voltage or current in proportion to the pressure.
	Auto-preset	Performs pressure setting automatically by detecting the increase and decrease in pressure. For example, if this function is used for a suction test, the pressure setting will be completed by performing suction and release of the workpiece.
B	Bottom value display (mode)	Shows the minimum pressure from when the power was supplied to the current time.
C	Chattering	The problem of the switch output turning ON and OFF repeatedly around the set value at high frequency due to the effect of pulsation.
	Chattering prevention function	A function to delay the response time of switch output in order to prevent chattering.
D	Delay time	The setting time from when the pressure applied to the pressure switch reaches the set value, to when the ON-OFF output actually begins working. Delay time setting can prevent the output from chattering.
	digit (Min. setting unit)	Shows how precisely the pressure can be displayed or set by the pressure switch. When 1 digit = 1 kPa, the pressure is displayed in increments of 1 kPa, e.g., 1, 2, 3, ..., 99, 100.
	Digital filter	Function to add digital filtering to the fluctuation of pressure value. Smooth the fluctuation of displayed value for sharp start up or fall of the pressure. When the function is valid, digital filtering is reflected to the ON/OFF of the switch output. Output chattering or flicker in the measurement mode display can be reduced by setting the digital filter. The response time indicates when the set value is 90% in relation to the step input.
	Display accuracy	Shows The maximum deviation between the displayed pressure value and the true pressure.
	Display resolving power	Indicate in how many the rated pressure range can be divided to display. (Example: When the value can be displayed down to 0.001 kPa for the product for -1.000 to 1.000 kPa, the resolution is 1/2000)
	Display value fine adjustment (function)	Displayed pressure value can be adjusted within the range of $\pm 5\%$ R.D. ($\pm 5\%$ of displayed value). It is used if the true pressure value is known, or to eliminate differences between the displayed values of different instruments that are measuring the same pressure.

	Term	Definition
E	Error displayed	The code number displayed, identifying the error detected by the self-diagnosis function of the pressure switch. Refer to "Device detail status parameters" on page 24 for details of the errors.
	Error output	Switches the switch output to ON/OFF when an error is displayed. Refer to "List of output modes" on page 30 for operating conditions. Refer to " Device detail status parameters" on page 24 for details of the errors.
F	F.S. (full span/full scale)	Abbreviation of full span and full scale; difference between the minimum and maximum rated pressure values. means the maximum fluctuation range of the pressure switch rated value. For example, when the rated pressure range is 0 to 1000 [kPa]: F.S. = 1000 - 0 = 1000 [kPa] (Reference: 1%F.S. = 1000 x 0.01 = 10 [kPa])
	Fine adjustment mode	Refer to "Display value fine adjustment (function)".
H	Hysteresis	Difference between the points at which the pressure switch is turned ON and OFF.
	Hysteresis mode	Refer to the "List of output modes" on page 30.
I	Insulation resistance	Insulation resistance of the product. The resistance between the electrical circuit and the case.
K	Key-lock function	Function that prevents changes to the settings of the pressure switch (disables button operation).
L	Load impedance	Refer to "Max. load impedance".
M	Manual setting	Manual pressure setup without using auto preset. This term is used to distinguish between manual and auto preset pressure setup.
	Maximum applied voltage	The maximum voltage that can be connected to the output of an NPN device.
	Maximum load current	The maximum current that can flow to the output (output line) of the switch output.
	Max. (Min.) load impedance	The maximum (minimum) load (resistance value and impedance) which can be connected to the output (output wire) of the analog current output.
	Measurement mode	Operating condition in which pressure is being detected and displayed, and the switch function is working.
	Min. setting unit	Refer to "digit".
N	Normal output	One of the switch output types. In hysteresis mode the switch output is turned ON when pressure equal to or greater than the switch output set value is detected. In window comparator mode, the switch output is turned ON when pressure between the switch output set values (P1L to P1H) is detected. (Refer to the "List of output modes" on page 30.)

	Term	Definition
O	Operation light	A light that turns on when the switch output is ON.
	Operation mode	Hysteresis mode, window comparator mode, Error output or Output off can be selected.
	Output style	The operation principle of the switch output. Normal output and reverse output can be selected. Please refer to the "List of output modes" on page 30 operating conditions.
P	Peak value display (mode)	Shows the maximum pressure from when the power was supplied to the current time.
	Pressure setting	The set pressure value that determines the point at which the pressure switch turns ON and OFF.
	Proof pressure	Pressure limit that if exceeded will result in mechanical and/or electrical damage to the product.
R	R.D.	Current read value For example, when the display value is 200[kPa], $\pm 5\%$ R.D. is $\pm 5\%$ of 200[kPa], which becomes ± 10 [kPa]. When the display value is 100[kPa], $\pm 5\%$ R.D. is $\pm 5\%$ of 100[kPa], which becomes ± 5 [kPa].
	Rated pressure range	The pressure range within which the product will meet all published specifications. Values outside of this range can be set as long as they are within the set pressure range, but the specifications cannot be guaranteed.
	Repeatability	Variation in repeated measurement of pressure display or ON-OFF output point when the pressure changes at 25 centigrade.
	Residual voltage	The difference between the ideal ON voltage and the actual voltage when the switch output is on. Varies with load current. Ideally should be 0 V.
	Resolution	Refer to "Display resolution".
	Reversed output	One of the switch output types. In hysteresis mode the switch output is turned ON when pressure less than or equal to the switch output set value is detected. In window comparator mode, the switch output is turned ON when pressure is outside the switch output set values (n1L to n1H) is detected. (Refer to the "List of output modes" on page 30.)
	Ripple	A type of chattering.

	Term	Definition
S	Set pressure range	The pressure range that can be set for switch output.
	Switch output	Sometimes referred to as "ON-OFF output".
U	Units selection function	A function to change the units in which the measured pressure value is displayed. The display units can only be changed if the product is equipped this function. It is not possible to purchase the product with this function if the product is used in Japan. The product for Japan is displayed in SI only.
W	Window comparator mode	An operating mode in which the switch output is turned on and off depending on whether the flow is inside or outside the range of two set values. (Refer to the "List of output modes" on page 30.)
	Withstand voltage	A measure of the product's resistance to a voltage applied between the electrical circuit and case. Durability in withstanding voltage. The product may be damaged if a voltage over this value is applied. (The withstand voltage is not the supply voltage used to power the product.)
Z	Zero-clear function	This function to adjust the displayed pressure to zero.

Mounting and Installation

■ Wiring

○ Wiring connections

- Connections should be made with the power supply turned off.
- Use a separate route for the product wiring and any power or high voltage wiring. Otherwise, malfunction may result due to noise.
- If a commercially available switching power supply is used, be sure to ground the frame ground (FG) terminal. If the switching power supply is connected for use, switching noise will be superimposed and it will not be able to meet the product specifications. In that case, insert a noise filter such as a line noise filter/ferrite between the switching power supplies or change the switching power supply to the series power supply.

○ Internal circuit and wiring examples

PSE54□□-□-□□

- Output specification

• Used as switch output device

-N

- NPN open collector 1 output
- Max. 30 V, 80 mA
- Residual voltage: 1.5 V or less

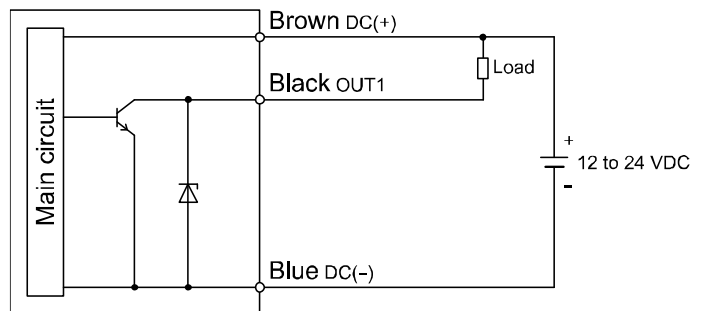

-P

- PNP open collector 1 output
- Max. 80 mA
- Residual voltage: 1.5 V or less

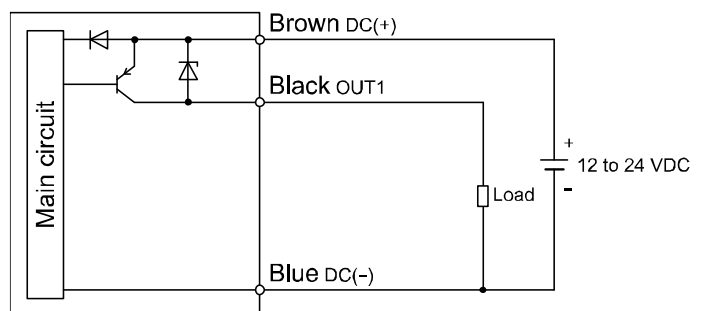

• Used as IO-Link device

-L

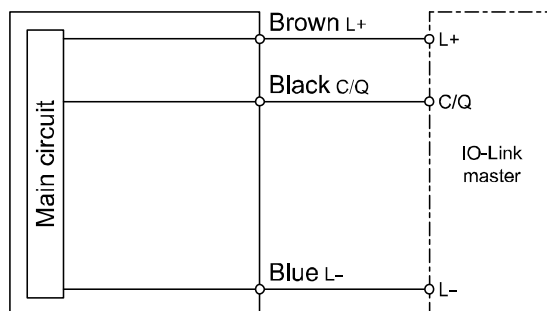

Pressure Setting

Default settings

When the pressure exceeds the set value, the switch will be turned on. When the pressure falls below the set value by the amount of hysteresis or more, the switch will be turned off. The default setting is to turn on the pressure switch when the pressure reaches the center of the atmospheric pressure and upper limit of the rated pressure range. (For output specification -L)

If this condition, shown to the below, is acceptable, then keep these settings.

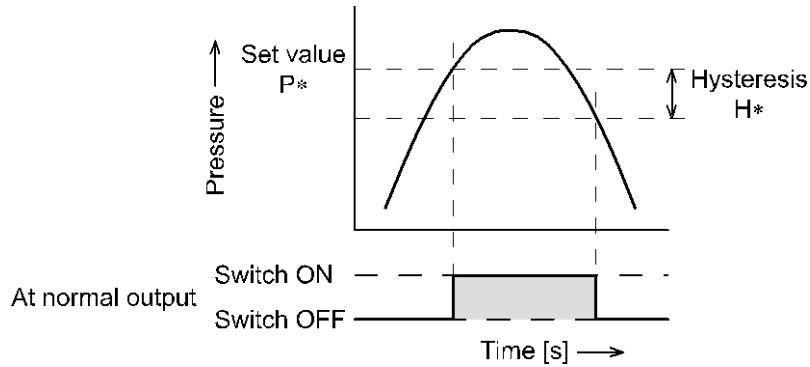

●PSE540#-L

Item	Default setting
[P1] Set value of OUT1	0.5 MPa
[H1] Hysteresis of OUT1	0.05 MPa

Item	Default setting
[P2] Set value of OUT2	0.5 MPa *
[H2] Hysteresis of OUT2	0.05 MPa *

●PSE541#-L

Item	Default setting
[P1] Set value of OUT1	-50.0 kPa
[H1] Hysteresis of OUT1	5.0 kPa

Item	Default setting
[P2] Set value of OUT2	-50.0 kPa *
[H2] Hysteresis of OUT2	5.0 kPa *

●PSE543#-L

Item	Default setting
[P1] Set value of OUT1	50.0 kPa
[H1] Hysteresis of OUT1	5.0 kPa

Item	Default setting
[P2] Set value of OUT2	50.0 kPa *
[H2] Hysteresis of OUT2	5.0 kPa *

*: Available only with IO-Link communication.

IO-Link Specifications (PSE54##-#-L# only)

■ Outline of IO-Link functions

○ Communication function

This product can check the pressure measurement value, diagnostic information and switch output status using cyclic data communication via the IO-Link system.

○ Product status monitoring function

This function monitors the product status via the IO-Link communication.

- Detects the error status (internal hardware error).
- Detects the warning conditions (measurement pressure error).

○ Data storage function

The Data storage function stores the IO-Link device parameter settings to the IO-Link master.

With the IO-Link data storage function, the IO-Link device can be replaced easily without re-setting the equipment construction or setting parameters

When the device parameters are set and downloaded to the device using the IO-Link setting tool, the parameters in the downloaded device will be activated.

After that, these parameters are uploaded to the data storage in the master by stem command (back-up communication command).

When the device is replaced with the same type of IO-Link device due to failure, the parameter settings stored in the master are downloaded automatically, device can be operated with the parameter settings of the previous device.

Device parameter setting is applicable to 3 types of back-up levels of the master setting ("Inactive", "back-up/Restore", "Restore").

"Back-up" implies the activation of upload and "restore" implies download.

■ Communication specifications

IO-Link type	Device
IO-Link version	V1.1
Communication speed	COM2 (38.4 kbps)
Min. cycle time	3.4 ms
Process data length	4 byte
On request data communication	Available
Data storage function	Available
Event function	Available

■ Process data

Process data is the data which is exchanged periodically between the master and device.
This product process data consists of switch output status, error diagnostics and pressure gauge measurement value.

(Refer to the table below.)

Bit offset	Item	Notes
0	OUT1 output	0: OFF 1: ON
1	OUT2 output	0: OFF 1: ON
2-7	-	Reserved
8	Measurement diagnosis	0: OFF 1: ON Out of range (HHH/LLL are displayed)
9-12	-	Reserved
13	Fixed output	0: OFF 1: ON
14	Diagnosis (Error)	0: OFF 1: ON When errors are generated (Er□□□ is displayed)
15	Diagnosis (System error)	0: OFF 1: ON When system errors are generated (Er□□□ is displayed)
16-31	Measurement value	With code 16 bit

Bit offset	31	30	29	28	27	26	25	24	23	22	21	20	19	18	17	16
Item	Input Measurement value (Integer with 16 bit code)															

Bit offset	15	14	13	12	11	10	9	8	7	6	5	4	3	2	1	0
Item	System error	Error (Other than system error)	Fixed output	0				Measurement diagnosis	0				OUT2	OUT1		

•The process data of this product is Big-Endian type.

When the transmission method of the upper communication is Little-Endian, the byte order will be changed.
Refer to the table below for the Endian type of the major upper communication.

Endian type	Upper communication protocol
Big-Endian type	Such as PROFIBUS and PROFINET
Little-Endian type	Such as EtherNET/IP, EtherCAT and CC-Link IE Field.

○Unit specification and measurement value (PD)

Range	Unit	Rated pressure range			Settable range		
		A	to	B	A	to	B
Positive pressure 1 MPa	kPa	0	to	1000	-105	to	1050
	MPa	0	to	1.0	-0.105	to	1.050
	kgf/cm ²	0	to	10.197	-1.07	to	10.71
	bar	0	to	10.0	-1.05	to	10.5
	psi	0	to	145.04	-15.2	to	152.3
	Pressure gauge measurement value (PD)	0	to	4000	-420	to	4200
Compound pressure ±100 kPa	KPa	-100.0	to	100.0	-105.0	to	105.0
	MPa	-0.100	to	0.100	-0.105	to	0.105
	kgf/cm ²	-1.0197	to	1.0197	-1.071	to	1.071
	bar	-1.0000	to	1.0000	-1.050	to	1.050
	psi	-14.504	to	14.504	-15.22	to	15.22
	inchHg	-29.53	to	29.53	-31.0	to	31.0
	mmHg	-750.1	to	750.1	-788	to	788
	Pressure gauge measurement value (PD)	-4000	to	4000	-4200	to	4200
Vacuum pressure -101 kPa	kPa	0	to	-101.0	10	to	-105.0
	MPa	0	to	-0.101	0.010	to	-0.105
	kgf/cm ²	0	to	-1.0299	0.102	to	-1.071
	bar	0	to	-1.010	0.100	to	-1.050
	Psi	0	to	-14.65	1.45	to	-15.23
	inchHg	0	to	-29.83	3.0	to	-31.0
	mmHg	0	to	-757.6	75	to	-788
	Pressure gauge measurement value (PD)	0	to	4040	-400	to	4200

*: The figure below describes the relationship between the pressure gauge measurement value (PD) and pressure value in the unit specification (kPa) of the range ±100 kPa.

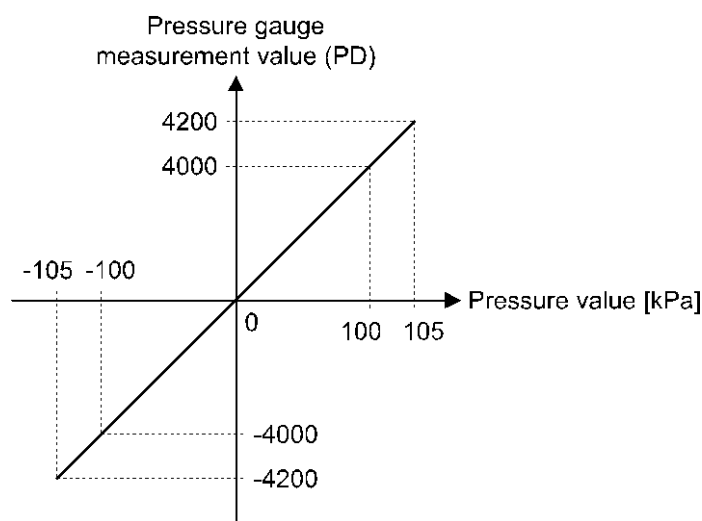

Relationship between the pressure gauge measurement value (PD) and pressure value (e.g.: Range ±100 kPa, unit kPa)

○ Conversion formula of the process data and pressure gauge measurement value

(1) Conversion formula from the process data to the pressure gauge measurement value:

$$Pr = a \times (PD) + b$$

(2) Conversion formula from the pressure gauge measurement value to the process data:

$$(PD) = (Pr - b) / a$$

Pr: Pressure gauge measurement value and set value

PD: Measurement value (process data)

a: Inclination

b: Intercept

[Inclination and intercept to the unit specification]

Range	Unit	Inclination a	Intercept b
Positive pressure 1 MPa	kPa	0.25	0
	MPa	0.00025	0
	kgf/cm ²	0.00254925	0
	bar	0.0025	0
	psi	0.0362595	0
Compound pressure ±100 kPa	kPa	0.025	0
	MPa	0.000025	0
	kgf/cm ²	0.000254925	0
	bar	0.00025	0
	psi	0.00362595	0
	inchHg	0.0073825	0
	mmHg	0.1875155	0
Vacuum pressure -100 kPa	kPa	-0.025	0
	MPa	-0.000025	0
	kgf/cm ²	-0.000254925	0
	bar	-0.00025	0
	psi	-0.00362595	0
	inchHg	-0.0073825	0
	mmHg	-0.1875155	0

[Calculation example]

(1) Conversion from the process data to the pressure measurement value

(For range ±100 kPa, unit specification kPa and PD = 2000)

$$\begin{aligned} Pr &= a \times (PD) + b \\ &= 0.025 \times 2000 + 0 \\ &= 50 \text{ [kPa]} \end{aligned}$$

(2) Conversion from the pressure measurement value to the process data

(For range ±100 kPa, unit specification kPa and Pr = 75.0 [kPa])

$$\begin{aligned} (PD) &= (Pr - b) / a \\ &= (75.0 - 0) / 0.025 \\ &= 3000 \end{aligned}$$

■IO-Link parameter setting

○IODD file

IODD (I/O Device Description) is a definition file which provides all properties and parameters required for establishing functions and communication of the device.

IODD includes the main IODD file and a set of image files such as vendor logo, device picture and device icon.

The IODD file is shown below.

	Product No.	IODD file *1
1	PSE540(A)-#-L	SMC-PSE540-L-yyyymmdd-IODD1.1
2	PSE541(A)-#-L	SMC-PSE541-L-yyyymmdd-IODD1.1
3	PSE543(A)-#-L	SMC-PSE543-L-yyyymmdd-IODD1.1

*1: "yyyymmdd" indicates the file preparation date. yyyy is the year, mm is the month and dd is the date.

IODD files can be downloaded from the SMC website.

*: If you want to use the unit selection function, please use "PSE54-L_IODD" in the configuration file.

Depending on the tool you use, you may not be able to use "PSE54-L_Pa_IODD" and "PSE54-L_IODD" at the same time.

In that case, please delete one before using.

*: Under the New Measurement Act, switches with a unit selection function are no longer allowed for use in Japan.

○Service data

The tables below indicates the parameters which can be read or written by simple access parameter (direct parameters page) and ISDU parameters which are applicable to various parameters and commands.

*: The parameter data of this product is the Big Endian type.

When the transmission method of the upper communication is Little-Endian, the byte order will be changed.

●Direct parameters page 1

DPP1 address	Access	Parameter name	Initial value (dec)	Contents
0x07	R	Vendor ID	0x0083 (131)	"SMC Corporation"
0x08				
0x09	R	Device ID	0x0002A5 (677)	"PSE540(A) - * - L"
0x0A			0x0002A6 (678)	"PSE541(A) - * - L"
0x0B			0x0002A7 (679)	"PSE543(A) - * - L"

●ISDU parameters

Index (dec)	Sub index	Access *1	Parameters	Initial value	Remarks
0x0002 (2)	0	W	System command	-	Refer to "System command" on page 23.
0x000C (12)	0	R/W	Device access lock	0x0000	Refer to "Device access lock parameters" on page 24.
0x0010 (16)	0	R	Vendor name	SMC Corporation	
0x0011 (17)	0	R	Vendor text	www.smcworld.com	
0x0012 (18)	0	R	Product name	Example: PSE540-L	
0x0013 (19)	0	R	Product ID	Example: PSE540-L	
0x0014 (20)	0	R	Product text	Pressure Sensor	
0x0015 (21)	0	R	Serial number	Example: "xxxxxxxx"	•Initial value is indicated as 8-digit. •16 octets fixed character string
0x0016 (22)	0	R	Hardware version	HW-Vx.y	x: Large revision number y: Small revision number
0x0017 (23)	0	R	Software version	FW-Vx.y	x: Large revision number y: Small revision number
0x0024 (36)	0	R	Device status parameter	-	Refer to "Device state parameters" on page 24.
0x0025 (37)	0	R	Device detailed state parameter	-	Refer to "Device detail status parameters" on page 24.
0x0028 (40)	0	R	Process data input	-	The latest value of process data can be read.

*1: R: Read, W: Write

●System command (index 2)

In the ISDU index 0x002 SystemCommand (system command), the command shown in the table below will be issued.

The button of each system command is displayed on the IO-Link setting tool (excluding "ParamDownloadStore").

Click the button to send the system command to the product.

Writable commands are shown below.

Data type: 8 bit UInteger

Value (dec)	Function definition	Description
0x80(128)	Device Reset	Restarts the device
0x81(129)	Application Reset	Clears peak/bottom value
0x82(130)	Restore Factory Settings	Restores factory default values
0xA0(160)	Zero Clear	Executes zero clear
0xF8(248)	Locator Start	Flashing operation light used to locate
0xF9(249)	Locator Stop	Operation light stops flashing

- Device access lock parameters (index 12)

The contents are as follows.

Data type: 16 bit Record

Value (dec)	Contents
0x0000(0)	DS unlock (Initial value)
0x0002(2)	DS lock
0x0008(8)	DS unlock
0x000A(10)	DS lock

[Lock data storage (DS lock)]

Locking "Data storage" will invalidate the data storage function of the pressure switch.

In this case, access will be denied for backup and restoration of data storage.

- Device state parameters (index 36)

Readable device states are as follows.

Data type: 8 bit UInteger

Value (dec)	State definition	Description
0x00(0)	Normal operation	-
0x01(1)	Maintenance inspection required	Not available
0x02(2)	Outside specification range	Measured pressure range upper limit exceeded Falls below measured pressure range lower limit
0x03(3)	Function check	Not available
0x04(4)	Failure	Internal failure of digital pressure switch

- Device detail status parameters (index 37)

Detailed event contents of readable device status are as follows.

Array	Event content	Event classification		Event code	Error output mode target
		Definition	Value		
1	Internal failure of pressure switch	Error	0xF4	0x8D03	Available
2	Internal failure of pressure switch	Error	0xF4	0x8D04	-
3	Internal failure of pressure switch	Error	0xF4	0x8D05	Available
4	Internal failure of pressure switch	Error	0xF4	0x8D01	Available
5	Internal failure of pressure switch	Error	0xF4	0x8D06	-
6	Internal failure of pressure switch	Error	0xF4	0x8CD0	Available
7	-	-	0x00	0x0000	-
8	Measured pressure range upper limit exceeded	warning	0xE4	0x8C10	-
9	Fell below measured pressure range lower limit	warning	0xE4	0x8C30	-
10	-	-	0x00	0x0000	-
11	-	-	0x00	0x0000	-
12	Data storage upload request	notification	0x54	0xFF91	-

●Product individual parameters

Index (dec)	Sub index	Access *1	Parameter	Data storage *2	Date type *3	Initial value (dec)	Remarks
0x03E8 (1000)	0	R/W	Unit (Selection of display unit)	Y	U8	PSE540: 0x00 (0) PSE541: 0x01 (1) PSE543: 0x01 (1)	Setting of display unit 0: MPa 1: kPa 2: kgf/cm ² 3: bar 4: psi 5: inchHg 6: mmHg
0x03FC (1020)	0	R/W	NorP (Selection of PNP/NPN)	Y	U8	0x01 (1)	Setting of switch output specification 0: NPN 1: PNP
0x04B0 (1200)	1	R/W	Output1(HW) (Selection of OUT1 hardware output target)	Y	U8	0x00 (0)	Setting of OUT1 hardware output target 0: HYS or wind 1: Err 2: oFF
	2	R/W	1ot(Error) (Selection of OUT1 normal/reversed output mode)	Y	U8	0x00 (0)	Setting of OUT1 output normal and reserved output at error output 0: 1_P (Normal output) 1: 1_n (Reserved output)
0x04BA (1210)	1	R/W	oUt1 (Selection of OUT1 output mode)	Y	U8	0x00 (0)	Setting of OUT1 output mode 0: HYS (Hysteresis) 1: Wind (Window comparator)
	2	R/W	1ot (Selection of OUT1 normal/reversed output mode)	Y	U8	0x00 (0)	Setting of OUT1 output normal and reserved output 0: 1_P (Normal output) 1: 1_n (Reserved output)
0x04C4 (1220)	1	R/W	P_1(n_1) (Setting of OUT1 output set value)	Y	U16	0x07D0 (2000)	Setting of OUT1 output set value Setting range PSE540: 0xFE5C ~ 0x1068 (-420 ~ 4200) PSE541: 0xFE70 ~ 0x1068 (-400 ~ 4200) PSE543: 0xEF98 ~ 0x1068 (-4200 ~ 4200)
	2	R/W	H_1 (Setting of OUT1 hysteresis)	Y	U16	0x00C8 (200)	Setting of OUT1 hysteresis Setting range PSE540: 0x0000 ~ 0x120C (0 ~ 4620) PSE541: 0X0000 ~ 0x11F8 (0 ~ 4600) PSE543: 0x0000 ~ 0x20D0 (0 ~ 8400)

●Product individual parameters (continued)

Index (dec)	Sub index	Access *1	Parameter	Data storage *2	Date type *3	Initial value (dec)	Remarks
0x04C4 (1220)	3	R/W	P1L(n1L) (Setting of OUT1 output set value_ Lower limit of window comparator)	Y	U16	0x04B0 (1200)	Setting of OUT1 output set value (lower limit of window comparator) Setting range PSE540: 0xFE5C ~ 0x1068 (-420 ~ 4200) PSE541: 0xFE70 ~ 0x1068 (-400 ~ 4200) PSE543: 0xEF98 ~ 0x1068 (-4200 ~ 4200))
	4	R/W	P1H(n1H) (Setting of OUT1 output set value_ Upper limit of window comparator)	Y	U16	0x0960 (2400)	Setting of OUT1 output set value (upper limit of window comparator) Setting range PSE540: 0xFE5C ~ 0x1068 (-420 ~ 4200) PSE541: 0xFE70 ~ 0x1068 (-400 ~ 4200) PSE543: 0xEF98 ~ 0x1068 (-4200 ~ 4200)
	5	R/W	WH1 (Setting of OUT1 hysteresis_ Window comparator hysteresis)	Y	U16	0x0190 (400)	Setting of OUT1 hysteresis (window comparator hysteresis) Setting range PSE540: 0x0000 ~ 0x0906 (0 ~ 2310) PSE541: 0X0000 ~ 0x08FC (0 ~ 2300) PSE543: 0x0000 ~ 0x1068 (0 ~ 4200)
	6	R/W	dtH1 (OUT1 delay time at ON)	Y	U16	0x0000 (0)	Setting of OUT1 delay time at ON Setting range 0x0000 ~ 0x1770 (0 ~ 6000) 0.01 s increment
	7	R/W	dtL1 (OUT1 delay time at OFF)	Y	U16	0x0000 (0)	Setting of OUT1 delay time at OFF Setting range 0x0000 ~ 0x1770 (0 ~ 6000) 0.01 s increment

●Product individual parameters (continued)

Index (dec)	Sub index	Access *1	Parameter	Data storage *2	Date type *3	Initial value (dec)	Remarks
0x0582 (1410)	1	R/W	oUt2 (Selection of OUT2 output mode)	Y	U8	0x00 (0)	Setting of OUT2 output mode 0: HYS (Hysteresis) 1: Wind (Window comparator)
	2	R/W	2ot (Selection of OUT2 normal/reversed output mode)	Y	U8	0x00 (0)	Setting of OUT2 output normal and reversed output 0: 2_P (Normal output) 1: 2_n (Reversed output)
0x058C (1420)	1	R/W	P_2(n_2) (Setting of OUT2 output set value)	Y	U16	0x07D0 (2000)	Setting of OUT2 output set value Setting range PSE540: 0xFE5C ~ 0x1068 (-420 ~ 4200) PSE541: 0xFE70 ~ 0x1068 (-400 ~ 4200) PSE543: 0xEF98 ~ 0x1068 (-4200 ~ 4200)
	2	R/W	H_2 (Setting of OUT2 hysteresis)	Y	U16	0x00C8 (200)	Setting of OUT2 hysteresis Setting range PSE540: 0x0000 ~ 0x120C (0 ~ 4620) PSE541: 0x0000 ~ 0x11F8 (0 ~ 4600) PSE543: 0x0000 ~ 0x20D0 (0 ~ 8400)
	3	R/W	P2L(n2L) (Setting of OUT2 output set value_ Lower limit of window comparator)	Y	U16	0x04B0 (1200)	Setting of OUT2 output set value (lower limit of window comparator) Setting range PSE540: 0xFE5C ~ 0x1068 (-420 ~ 4200) PSE541: 0xFE70 ~ 0x1068 (-400 ~ 4200) PSE543: 0xEF98 ~ 0x1068 (-4200 ~ 4200)
	4	R/W	P2H(n2H) (Setting of OUT2 output set value_ Upper limit of window comparator)	Y	U16	0x0960 (2400)	Setting of OUT2 output set value (upper limit of window comparator) Setting range PSE540: 0xFE5C ~ 0x1068 (-420 ~ 4200) PSE541: 0xFE70 ~ 0x1068 (-400 ~ 4200) PSE543: 0xEF98 ~ 0x1068 (-4200 ~ 4200)

●Product individual parameters (continued)

Index (dec)	Sub index	Access *1	Parameter	Data storage *2	Date type *3	Initial value (dec)	Remarks
0x058C (1420)	5	R/W	WH2 (Setting of OUT2 hysteresis_ Window comparator hysteresis)	Y	U16	0x0190 (400)	Setting of OUT2 hysteresis (window comparator hysteresis) Setting range PSE540: 0x0000 ~ 0x0906 (0 ~ 2310) PSE541: 0x0000 ~ 0x08FC (0 ~ 2300) PSE543: 0x0000 ~ 0x1068 (0 ~ 4200)
	6	R/W	dtH2 (OUT2 delay time at ON)	Y	U16	0x0000 (0)	Setting of OUT2 delay time at ON Setting range 0x0000 ~ 0x1770 (0 ~ 6000) 0.01 s increment
	7	R/W	dtL2 (OUT2 delay time at OFF)	Y	U16	0x0000 (0)	Setting of OUT2 delay time at OFF Setting range 0x0000 ~ 0x1770 (0 ~ 6000) 0.01 s increment
0x0708 (1800)	0	R/W	FIL (Digital filter)	Y	U16	0x0000 (0)	Setting of digital filter 0x0000 ~ 0x0BB8 (0 ~ 3000) 0.01 s increment
0x0712 (1810)	0	R/W	FSC (Display value fine adjustment ratio)	N	S16	0x0000 (0)	Displayed pressure value can be adjusted within $\pm 5\%$ R.D. 0xFFCE ~ 0x0032 (-50 ~ 50) 0.1% increments
0x07EE (2030)	0	R/W	Cut (Zero-cut)	Y	U8	0	Display value around 0 is displayed as 0. Setting range 0x00 ~ 0x64 0 ~ 100 0.1% increments
0x1F40 (8000)	0	R	Measurement related	Process data Conversion formula Inclination a	N	F32	Refer to table "Inclination and intercept to the unit specification". (Page 21)
0x1F4A (8010)	0	R		Process data Conversion formula Intercept b	N	F32	
0x1F54 (8020)	0	R		Peak value	N	U16	Refer to process data on page 19 to 21.
0x1F5E (8030)	0	R		Bottom value	N	U16	

●Product individual parameters (continued)

Index (dec)	Sub index	Access *1	Parameter	Data storage *2	Date type *3	Initial value (dec)	Remarks
0x1F72 (8050)	0	R	Diagnostic information Number of pressurizing errors	N	U16	0	0 ~ 1000

*1: "R" means Read and "W" means Write.

*2: "Y" indicates that the parameter setting data is saved to the master, and "N" indicates that the parameter is not saved.

*3: Refer to the table below for the symbol.

Symbol	Data type (IO-Link standard)	Data length Bit [byte]	Description
U8	UIntegerT	8[1]	Unsigned integer
U16		16[2]	
S16	IntegerT	16[2]	Signed integer
F32	Float32T	32[4]	Floating point number

•List of output modes

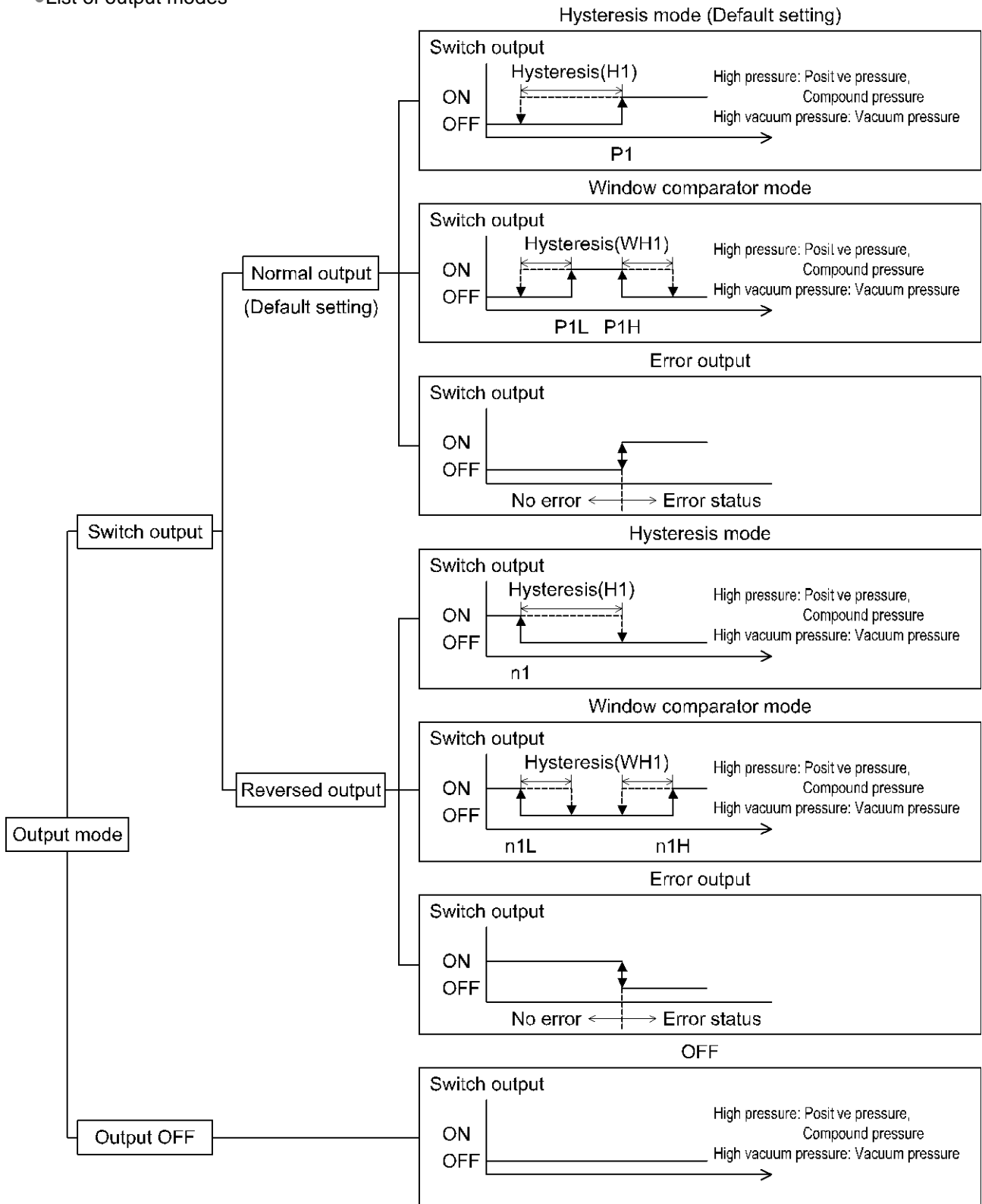

*: The chart above shows the OUT1 operation. For OUT2, all "1" in the chart will be changed to "2". (example P1→P2)

If the point at which the switch output changes is outside of the set pressure range due to the selection of normal or reversed output, the hysteresis value is automatically adjusted.

Setting of the error output

In reversed output mode, error output not supported error can be detected.

Normal output

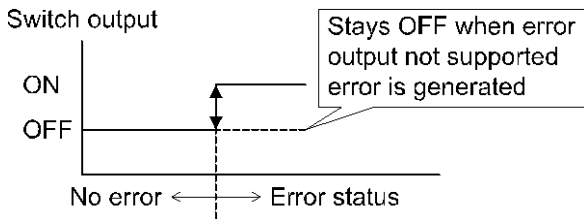

Reversed output

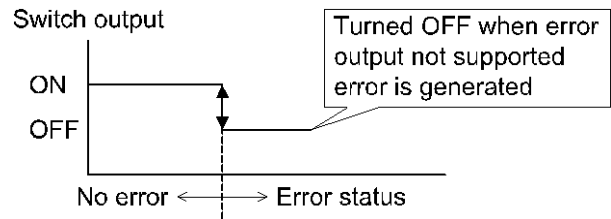

Maintenance

How to reset the product after a power cut or forcible de-energizing

The setting of the product will be retained as it was before a power cut or de-energizing. The output condition is also basically recovered to that before a power cut or de-energizing, but may change depending on the operating environment. Therefore, check the safety of the whole installation before operating the product. If the installation is using accurate control, wait until the product has warmed up (approximately 20 to 30 minutes).

Troubleshooting

○ Troubleshooting

Applicable pressure switch: **PSE54**

When any failure occurs with this product, the following chart can be used to identify the cause of the failure. If a cause applicable to the troubles cannot be identified and normal operation is recovered by replacement with a new product, this indicates that the product itself was faulty. Problems with the product may be due to the operating environment (installation etc). Please consult SMC.

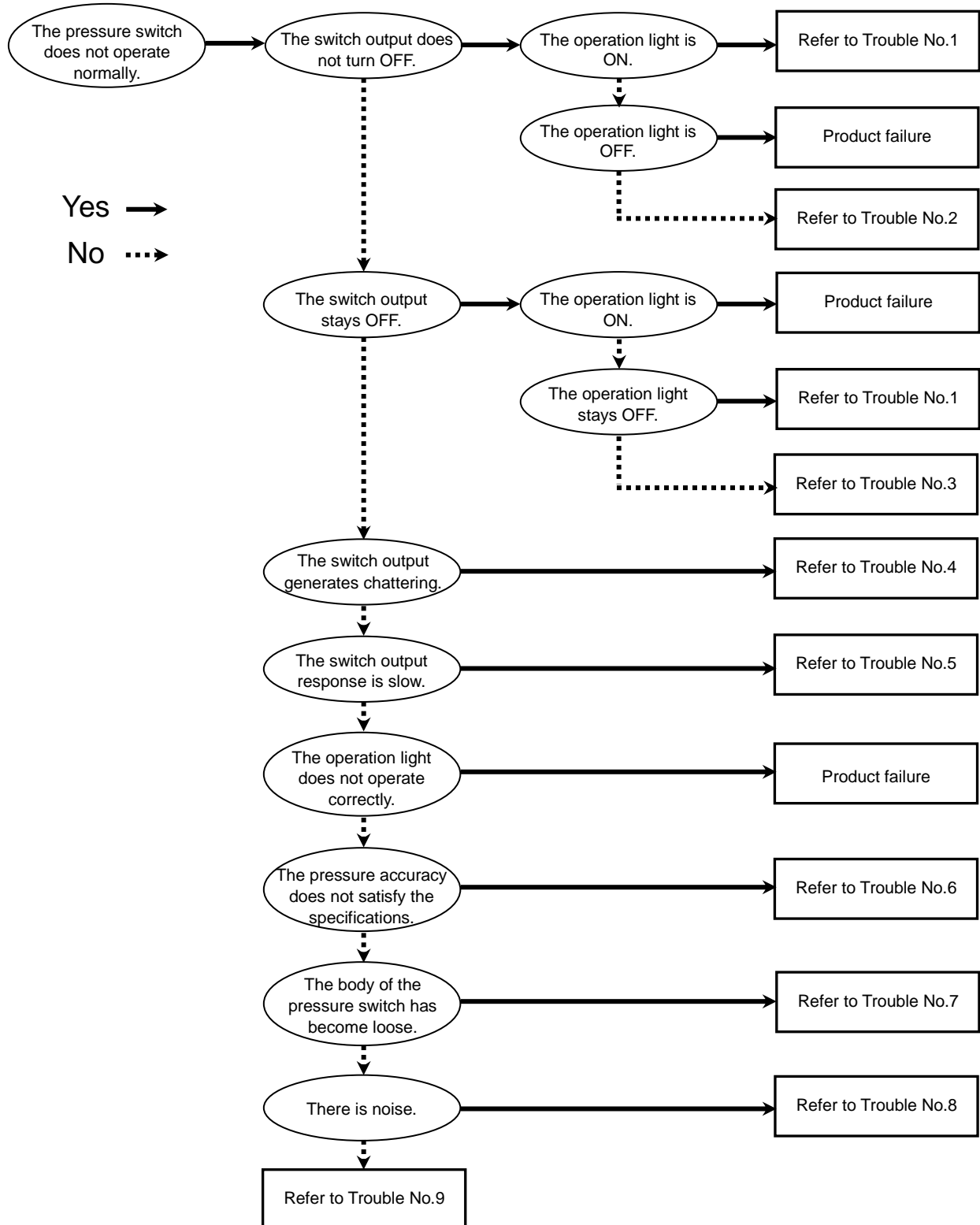

○Troubleshooting list

Problem No.	Problem	Problem possible causes	Investigation method	Countermeasures
1	<ul style="list-style-type: none"> •Output remains ON. Indicator LED remains ON. •Output remains OFF. Indicator LED remains OFF. 	Incorrect pressure setting	(1) Check the set pressure. (2) Check the operation mode, hysteresis and output type. (hysteresis mode/window comparator mode, normal/reversed output)	(1) Reset the pressure setting. (2) Reset the function settings.
		Incorrect operation of the internal data of the pressure switch	(1) Check that there is no noise interference such as static electricity, and check for noise sources. (2) Check that the power supply voltage is within the range 12 to 24 VDC $\pm 10\%$.	(1) Remove the noise and the noise source (or take measures to prevent noise interference), and reset the product or turn off the power supply. Then, supply the power again. (2) Supply a correct voltage of 12 to 24 VDC $\pm 10\%$.
		Product failure		Replace the product.
2	Output remains ON. Indicator LED works correctly.	Incorrect wiring	Check the wiring of the output. Check if the load is connected directly to DC(+) or DC(-).	Correct the wiring.
		Incorrect operation of the internal data of the pressure switch	(1) Check that there is no noise interference such as static electricity, and check for noise sources. (2) Check that the power supply voltage is within the range 12 to 24 VDC $\pm 10\%$.	(1) Remove the noise and the noise source (or take measures to prevent noise interference), and reset the product or turn off the power supply. Then, supply the power again. (2) Supply a correct voltage of 12 to 24 VDC $\pm 10\%$.
		Product failure		Replace the product.

Problem No.	Problem	Problem possible causes	Investigation method	Countermeasures
3	Output remains OFF. Indicator LED works correctly.	Incorrect wiring	Check the wiring of the output. Check if the load is connected directly to DC(+) or DC(-).	Correct the wiring.
		Unsuitable model selection	Check if PNP is used when NPN should have been selected, or the other way around.	Review the selected model (output type).
		Broken lead wire	Check if there is bending stress applied to any parts of the lead wire. (bending radius and tensile force applied)	Correct the wiring conditions. (adjust the tensile force and increase the bending radius.)
		Incorrect operation of the internal data of the pressure switch	(1) Check that there is no noise interference such as static electricity, and check for noise sources. (2) Check that the power supply voltage is within the range 12 to 24 VDC $\pm 10\%$.	(1) Remove the noise and the noise source (or take measures to prevent noise interference), and reset the product or turn off the power supply. Then, supply the power again. (2) Supply a correct voltage of 12 to 24 VDC $\pm 10\%$.
		Product failure		Replace the product.
4	Switch output generates chattering.	Incorrect wiring	Check the wiring. Check if the brown and blue wires are connected to DC(+) and DC(-) respectively, and if the output wiring is loose (contact failure).	Correct the wiring.
		Incorrect settings	(1) Check the set pressure. (2) Check that the hysteresis range is not too narrow. (3) Check the delay time setting. Check if the delay time is too short.	(1) Reset the pressure setting. (2) Increase the hysteresis. (3) Reset the function settings.
		Over current to the output	(1) Check that the switch output load current is not more than 80 mA. (2) Check that the connected load satisfies the specifications, and check the load for short circuits. (3) Check that any relay is connected with a surge voltage suppressor. (4) Check if the wiring is not in the same route as (or bundled together with) a high voltage cable or power cable.	(1), (2) Connect the load as specified. (3) Use a relay with a surge voltage suppressor or take measures to prevent noise. (4) Separate the wiring route from any high voltage cable or power cable.
		Product failure		Replace the product.
5	Slow switch output response	Incorrect pressure setting	Check the pressure setting. Check that the detected pressure and the set pressure value are not the same or not too close.	Reset the pressure setting. Set the pressure setting value so it is not too close to the detected pressure.

Problem No.	Problem	Problem possible causes	Investigation method	Countermeasures
6	The pressure accuracy does not satisfy the specifications.	Foreign matter	Check if any foreign matter has entered the piping port.	Install a 5 μm filter to prevent foreign matter from entering the piping port. Also, clean the filter regularly to prevent drainage deposits.
		Air or fluid leakage	Check if air or fluid are leaking from the piping.	Rework the piping. If an excessive tightening torque is applied, the mounting bracket, screws or the product may be damaged.
		Insufficient warm-up time	Check if the product satisfies the specified accuracy after 10 minutes warm up time.	After energizing, the display and output can drift. For detecting fine pressures, warm up the product for 10 to 15 minutes.
		Product failure		Replace the product.
7	The product is loose.	Incorrect installation	Check that the panel mount adapter and the product are correctly assembled.	Mount the product on the panel correctly.
		Product failure		Replace the product.
8	The product is noisy.	Air or fluid leakage	Check if air or fluid are leaking from the piping.	Rework the piping. If an excessive tightening torque is applied, the mounting bracket, screws or the product may be damaged.
		Product failure		Replace the product.
9	The operation is unstable. (chattering)	Effect of line pressure fluctuation because hysteresis is too narrow or delay time of the switch is too short	(1) Check the set pressure values (hysteresis) (2) Check the delay time.	(1) Check the pressure setting. (2) Reset the function settings.
		Incorrect wiring or broken lead wire	(1) Check the power supply wiring. (2) Check if there is bending stress applied to any parts of the lead wire.	(1) Correct the wiring (2) Correct the wiring conditions (reduce the tensile force and increase the bending radius).
		Product failure		Replace the product.

○Troubleshooting (IO-Link communication function)

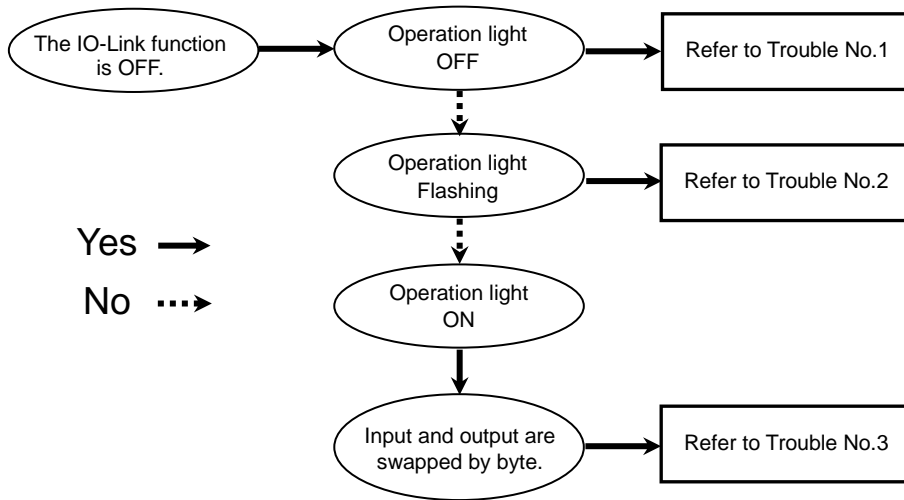

○Troubleshooting list (IO-Link communication)

Problem No.	Problem	Problem possible causes	Investigation method	Countermeasures
1	Operation light OFF	incorrect wiring	Check the connection of the connector.	Correct the cable wiring.
		Power supply error from the IO-Link master	Check the power supply voltage from the IO-Link master.	Supply 18 to 30 VDC to the IO-Link master.
2	Operation light Flashing	Communication is not established. IO-Link wiring failure	Check the connection and cable condition of the IO-Link cable.	Additionally tighten the IO-Link cable. (Replace the cable if it is broken.)
		IO-Link master and product version are not matched.	Check the IO-Link version of the master and device.	Align the master IO-Link version to the device. *1
		Communication mode is not transferred to the Operation mode.	Check the setting of the data storage access lock and data storage backup level of the master.	Release the data storage access lock. Or deactivate the setting of the data storage backup level of the master port.
		Backup and restore required during data storage lock	Check the data storage lock.	Release the data storage lock.
4	Data is swapped by byte.	Program data assignment is incorrect.	Check that the Endian type on the master upper level communication transmission format is Big Endian type or Little Endian type.	Assign the program data based on the Endian type of the transmission format of the master upper level communication. Or set to the master byte swap setting. (Refer to page 19 for the Endian type of the upper level communication.)

*1: When the product is connected to the master with version "V1.0", error is generated.

○IO-Link status list

Operation light	Content
Flashing 2 times	Receiving Restore Factory Setting Receiving Peak Bottom Clear Receiving Zero Clear Receiving Application Reset

*: When the operation is completed, the display will return to normal.

Operation light	Content
Repeat flashing 2 times	Receiving Locator Start

*: When Locator Stop is received, the display will return to normal.

Specification

IO-Link

Product No.		PSE540(A)-#-L	PSE541(A)-#-L	PSE543(A)-#-L
Rated pressure range *5		-0.100 to 1.000 MPa	0.0 to -101.0 kPa	-100.0 to 100.0 kPa
Set pressure range *5		-0.105 to 1.050 MPa	10.0 to -105.0 kPa	-105.0 to 105.0 kPa
Min. setting unit *5		0.001 MPa	0.1 kPa	0.1 kPa
Proof pressure		1.5 MPa	500 kPa	
Applicable fluid		Air, non-corrosive gas and non-flammable gas		
Power supply voltage	Used as switch output device	12 to 24 VDC ($\pm 10\%$), and power supply ripple (p-p) 10% at max.		
	Used as IO-Link device	18 to 26.4 VDC, ripple max.10% (p-p)		
	Protection	Polarity protection		
Current consumption		35 mA or less		
Output specification	Output type	Select from NPN open collector 1 output, PNP open collector 1 output *2		
	Output mode	Hysteresis mode, window comparator mode, error output		
	Switch operation	Normal output, reversed output		
	Hysteresis	Variable from 0 *4		
	Max. load current	80 mA		
	Max. applied voltage (NPN output)	30 V		
	Internal voltage drop (Residual voltage)	1.5 V or less (Load current 80 mA)		
Delay time *1		3.4 ms or less, variable from 0 to 60 s/0.01 s increments		
Accuracy (at ambient temperature 25 °C)		PSE54#A: $\pm 1\%$ F.S. (at rated pressure range) $\pm 3\%$ F.S. (at extension pressure range) *6 PSE54#: $\pm 2\%$ F.S. (at rated pressure range) $\pm 5\%$ F.S. (at extension pressure range) *6		
Linearity		$\pm 0.7\%$ F.S.	$\pm 0.4\%$ F.S.	
Repeatability		$\pm 0.2\%$ F.S.		
Effect of power supply voltage		$\pm 0.8\%$ F.S.		
Environment	Enclosure	IP40		
	Withstand voltage	1000 VAC 50/60 Hz for 1 minute between terminals and housing		
	Insulation resistance	50 M Ω or more between terminals and housing (with 500 VDC megger)		
	Ambient temperature range	Operation: 0 to 50 °C, Storage: -10 to 60 °C (No condensation or freezing)		
	Operating humidity range	Operation, Storage: 35 to 85%RH (No condensation)		
Standard		CE/UKCA marked, UL/CSA (E216656)		

*1: Value without digital filter (at 0 ms).

*2: OUT1 is switchable. PNP open collector output (initial value).

*3: Any products with tiny scratches, smears, or variations in the display color or brightness, which does not affect the performance of the product, are verified as conforming products.

*4: If the applied pressure fluctuates around the set value, the hysteresis must be set to a value more than the amount of fluctuation or chattering will occur.

*5: This is the set value when using a IODD file.

*6: Extension pressure range is the range (set pressure range - rated pressure range).

○ Switch output

Product No.		PSE540(A)-#-L	PSE541(A)-#-L	PSE543(A)-#-L
Rated pressure range		-0.10 to 1.00 MPa	0 to -101 kPa	-100 to 100 kPa
Set pressure range		-0.10 to 1.05 MPa	10 to -105 kPa	-105 to 105 kPa
Min. setting unit		Refer to OUT1 set value, hysteresis		
Proof pressure		1.5 MPa	500 kPa	
Applicable fluid		Air, non-corrosive gas and non-flammable gas		
Power supply voltage	Used as switch output device	12 to 24 VDC ($\pm 10\%$), and power supply ripple (p-p) 10% at max.		
	Protection	Polarity protection		
Current consumption		35 mA or less		
Output specification	Output type	NPN open collector 1 output, PNP open collector 1 output		
	Output mode	Hysteresis mode		
	Switch operation	Normal output, reversed output		
	Hysteresis	Variable from 0 ^{*3}		
	Max. load current	80 mA		
	Max. applied voltage (NPN output)	30 V		
	Internal voltage drop (Residual voltage)	1.5 V or less (Load current 80 mA)		
Delay time ^{*1}		3.4 ms or less, variable from 0 to 60 s/0.01 s increments		
Accuracy (at ambient temperature 25 °C)		PSE54#A: $\pm 1\%$ F.S. (at rated pressure range) $\pm 3\%$ F.S. (at extension pressure range) ^{*4} PSE54#: $\pm 2\%$ F.S. (at rated pressure range) $\pm 5\%$ F.S. (at extension pressure range) ^{*4}		
Linearity		$\pm 0.7\%$ F.S.	$\pm 0.4\%$ F.S.	
Repeatability		$\pm 0.2\%$ F.S.		
Effect of power supply voltage		$\pm 0.8\%$ F.S.		
Environment	Enclosure	IP40		
	Withstand voltage	1000 VAC 50/60 Hz for 1 minute between terminals and housing		
	Insulation resistance	50 M Ω or more between terminals and housing (with 500 VDC megger)		
	Ambient temperature range	Operation: 0 to 50 °C, Storage: -10 to 60 °C (No condensation or freezing)		
	Operating humidity range	Operation, Storage: 35 to 85%RH (No condensation)		
Standard		CE/UKCA marked, UL/CSA (E216656)		

*1: Value without digital filter (at 0 ms).

*2: Any products with tiny scratches, smears, or variations in the display color or brightness, which does not affect the performance of the product, are verified as conforming products.

*3: If the applied pressure fluctuates around the set value, the hysteresis must be set to a value more than the amount of fluctuation or chattering will occur.

*4: Extension pressure range is the range (set pressure range - rated pressure range).

○Piping/weight specifications

Product No.		M3	M5	01	N01	R04	R06	IM5	IM5H
Port size		M3 x 0.5	M5 x 0.8	R1/8 M5 x 0.8	NPT1/8 M5 x 0.8	φ4 reducer	φ6 reducer	M5 female thread, through type	M5 female thread, through type (with setting hole)
Materials	Case part	Resin case: PC Fitting: SUS303		Resin case: PC Fitting: C3604BD		PC Fitting: PBT		Resin case: PC Fitting: A6063S-T5	
	Pressure detecting part	Sensor pressure receiving part: Silicone, O-ring: NBR							
Weight	With cable for sensor	43.6 g	43.9 g	50.5 g		42.6 g	42.8 g	44.5 g	45.3 g
	Without cable for sensor	4.1 g	4.4 g	11 g		3.1 g	3.3 g	5.0 g	5.8 g

○Cable specifications

Oilproof heavy-duty vinyl cable (Oval) 3 core 2.7 x 3.2 3 m		
Conductor area		0.15 mm ²
Insulator	Outside diameter	0.9 mm

○Communication specifications (During IO-Link mode)

IO-Link type	Device
IO-Link version	V1.1
Communication speed	COM2 (38.4 kbps)
Configuration file	IODD file *1
Min. cycle time	3.4 ms
Process data length	Input Data: 4 byte, Output Data: 0 byte
On request data communication	Available
Data storage function	Available
Event function	Available
Vendor ID	131(0x0083)
Device ID	PSE540(A)-*-L: 0x0002A5 PSE541(A)-*-L: 0x0002A6 PSE543(A)-*-L: 0x0002A7
Operation light	SIO mode: Light up when switch output turned on. OUT1: Red IO-Link communication: Light up when switch output turned on. In IO-Link mode, Operation light is ON or flashes. OUT1: Red

*1: For more information about configuration files, please contact our sales branch.

■ Dimensions

- PSE54#(A)- M3
M5

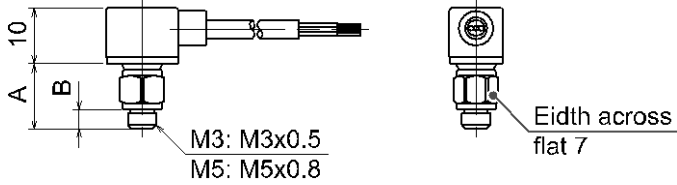

	PSE54#(A)-M3	PSE54#(A)-M5
A	10.8	11.5
B	3	3.5

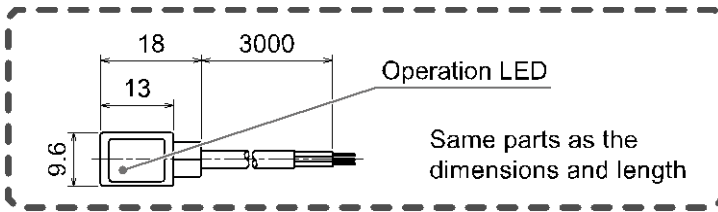

- PSE54#(A)- 01
N01

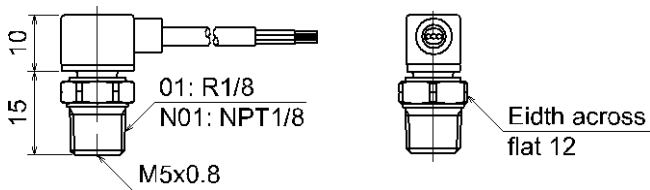

- PSE54#(A)- R04
R06

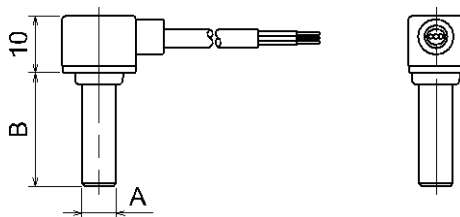

	PSE54#(A)-R04	PSE54#(A)-R06
A	$\phi 4$	$\phi 6$
B	18	20

- PSE54#(A)-IM5

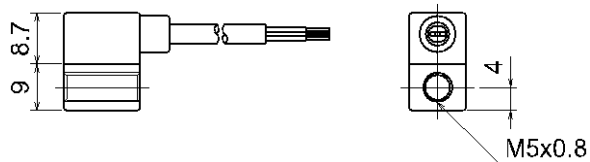

- PSE54#(A)-IM5H

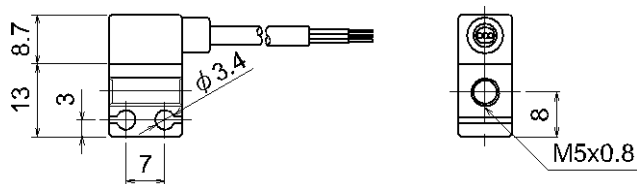

•PSE54#(A)-#S

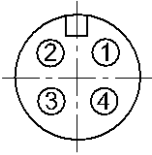
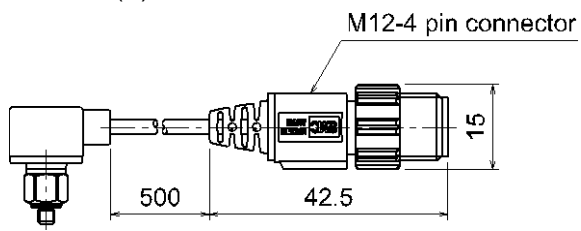

Connector pin-out

Pin No.	Switch output	IO-Link
	Description	
1	DC(+)	L+
2	N.C.	N.C.
3	DC(-)	L-
4	OUT	C/Q

Revision history

- 1: Contents revised in several places.
[February 2024]
- 2: Contents revised in several places.
[March 2024]
- 3: Contents revised in several places. [June 2024]

SMC Corporation

Tel: + 81 3 5207 8249 Fax: +81 3 5298 5362
URL <https://www.smcworld.com>

Note: Specifications are subject to change without prior notice and any obligation on the part of the manufacturer.
© SMC Corporation All Rights Reserved

