



Operation Manual

PRODUCT NAME

PSE Sensor Set Up Tool

MODEL / Series / Product Number

PSE-ST

SMC Corporation

Table of Contents

Safety Instructions	3
Model Indication and How to Order	9
Summary of Product parts	10
Definition and terminology	11
Wiring	14
Outline of Settings	16
3 Step Setting Mode	18
All Settings Reference Mode	20
All settings reference mode	20
Function Selection Mode	21
Function selection mode	21
Default setting	21
F 0 Display unit, switch output specification switching function	22
F 1 Setting of OUT1	23
F 2 Setting of OUT2	27
F 3 Digital filter setting	30
F 6 Fine adjustment of measurement value	31
F14 Zero cut-off setting	32
F94 Other function settings	33
F96 Measurement process data display, SW output point display	34
F97 Selection of copy function	35
F99 Reset to initial settings	37
Locator Mode	38
Locator mode	38
Other Settings	39
Troubleshooting	40
Specifications	46
Dimensions	47



Safety Instructions

These safety instructions are intended to prevent hazardous situations and/or equipment damage. These instructions indicate the level of potential hazard with the labels of “**Caution**,” “**Warning**” or “**Danger**.” They are all important notes for safety and must be followed in addition to International Standards (ISO/IEC)^{*1)}, and other safety regulations.

*1) ISO 4414: Pneumatic fluid power - General rules and safety requirements for systems and their components
ISO 4413: Hydraulic fluid power - General rules and safety requirements for systems and their components
IEC 60204-1: Safety of machinery - Electrical equipment of machines - Part 1: General requirements
ISO 10218-1: Robots and robotic devices - Safety requirements for industrial robots - Part 1: Robots
etc.



Danger

Danger indicates a hazard with a high level of risk which, if not avoided, will result in death or serious injury.



Warning

Warning indicates a hazard with a medium level of risk which, if not avoided, could result in death or serious injury.



Caution

Caution indicates a hazard with a low level of risk which, if not avoided, could result in minor or moderate injury.



Warning

1. The compatibility of the product is the responsibility of the person who designs the equipment or decides its specifications.

Since the product specified here is used under various operating conditions, its compatibility with specific equipment must be decided by the person who designs the equipment or decides its specifications based on necessary analysis and test results. The expected performance and safety assurance of the equipment will be the responsibility of the person who has determined its compatibility with the product. This person should also continuously review all specifications of the product referring to its latest catalog information, with a view to giving due consideration to any possibility of equipment failure when configuring the equipment.

2. Only personnel with appropriate training should operate machinery and equipment.

The product specified here may become unsafe if handled incorrectly. The assembly, operation and maintenance of machines or equipment including our products must be performed by an operator who is appropriately trained and experienced.

3. Do not service or attempt to remove product and machinery/equipment until safety is confirmed.

1. The inspection and maintenance of machinery/equipment should only be performed after measures to prevent falling or runaway of the driven objects have been confirmed.
2. When the product is to be removed, confirm that the safety measures as mentioned above are implemented and the power from any appropriate source is cut, and read and understand the specific product precautions of all relevant products carefully.
3. Before machinery/equipment is restarted, take measures to prevent unexpected operation and malfunction.

4. SMC products cannot be used beyond their specifications. They are not developed, designed, and manufactured to be used under the following conditions or environments. Use under such conditions or environments is not allowed.

1. Conditions and environments outside of the given specifications, or use outdoors or in a place exposed to direct sunlight.
2. Use for nuclear power, railways, aviation, space equipment, ships, vehicles, military application, equipment affecting human life, body, and property, combustion equipment, entertainment equipment, emergency shut-off circuits, press clutches, brake circuits, safety equipment, etc., and use for applications that do not conform to standard specifications such as catalogs and operation manuals.
3. Use for interlock circuits, except for use with double interlock such as installing a mechanical protection function in case of failure. Please periodically inspect the product to confirm that the product is operating properly.



Safety Instructions

Caution

SMC develops, designs, and manufactures products to be used for automatic control equipment, and provides them for peaceful use in manufacturing industries.

Use in non-manufacturing industries is not allowed.

Products SMC manufactures and sells cannot be used for the purpose of transactions or certification specified in the Measurement Act of each country.

The new Measurement Act prohibits use of any unit other than SI units in Japan.

Limited warranty and Disclaimer/Compliance Requirements

The product used is subject to the following "Limited warranty and Disclaimer" and "Compliance Requirements".

Read and accept them before using the product.

Limited warranty and Disclaimer

1. The warranty period of the product is 1 year in service or 1.5 years after the product is delivered, whichever is first.*2)
Also, the product may have specified durability, running distance or replacement parts. Please consult your nearest sales branch.
2. For any failure or damage reported within the warranty period which is clearly our responsibility, a replacement product or necessary parts will be provided.
This limited warranty applies only to our product independently, and not to any other damage incurred due to the failure of the product.
3. Prior to using SMC products, please read and understand the warranty terms and disclaimers noted in the specified catalog for the particular products.

***2) Vacuum pads are excluded from this 1 year warranty.**

A vacuum pad is a consumable part, so it is warranted for a year after it is delivered.

Also, even within the warranty period, the wear of a product due to the use of the vacuum pad or failure due to the deterioration of rubber material are not covered by the limited warranty

Compliance Requirements

1. The use of SMC products with production equipment for the manufacture of weapons of mass destruction (WMD) or any other weapon is strictly prohibited.
2. The exports of SMC products or technology from one country to another are governed by the relevant security laws and regulations of the countries involved in the transaction. Prior to the shipment of a SMC product to another country, assure that all local rules governing that export are known and followed.

Operator

- ◆ This operation manual is intended for those who have knowledge of machinery using pneumatic equipment, and have sufficient knowledge of assembly, operation and maintenance of such equipment. Only those persons are allowed to perform assembly, operation and maintenance.
- ◆ Read and understand this operation manual carefully before assembling, operating or providing maintenance to the product.

■ Safety Instructions

Warning

- Do not disassemble, modify (including changing the printed circuit board) or repair.
An injury or failure can result.
- Do not operate the product outside of the specifications.
Do not use for flammable or harmful fluids.
Fire, malfunction, or damage to the product can result.
Verify the specifications before use.
- Do not operate in an atmosphere containing flammable or explosive gases.
Fire or an explosion can result.
This product is not designed to be explosion proof.
- Do not use the product in a place where static electricity is a problem.
Otherwise it can cause failure or malfunction of the system.
- If using the product in an interlocking circuit:
 - Provide a double interlocking system, for example a mechanical system
 - Check the product regularly for proper operationOtherwise malfunction can result, causing an accident.
- The following instructions must be followed during maintenance:
 - Turn off the power supply
 - Stop the air supply, exhaust the residual pressure and verify that the air is released before performing maintenanceOtherwise an injury can result.

Caution

- Do not touch the terminals and connectors while the power is on.
Otherwise electric shock, malfunction or damage to the product can result.
- After maintenance is complete, perform appropriate functional inspections and leak tests.
Stop operation if the equipment does not function properly or there is a leakage of fluid.
When leakage occurs from parts other than the piping, the product might be faulty.
Disconnect the power supply and stop the fluid supply.
Do not apply fluid under leaking conditions.
Safety cannot be assured in the case of unexpected malfunction.

■ NOTE

- Follow the instructions given below when designing, selecting and handling the product.
- The instructions on design and selection (installation, wiring, environment, adjustment, operation, maintenance, etc.) described below must also be followed.
- *Product specifications
 - Use the specified pressure sensor.
Other products may not operate correctly.
 - Depending on the mobile battery used, this product may not operate.
Use this product by connecting it to a mobile battery with a 5 VDC, 2 A output minimum.
Depending on the type of mobile battery, it may not operate.
If the product is connected to a mobile battery that has a function to automatically turn off the power supply according to the current consumption of the mobile battery, this product may not operate.
Also, do not connect to any power source other than a mobile battery. If it does not operate, there is a risk that the power supply may be faulty.
It is recommended to use a mobile battery that can be switched on and off.
 - Use a mobile battery that complies with the laws and regulations of each region and country.
SMC do not guarantee against any damage caused by the use of illegal mobile batteries, or any damage caused by the malfunction of our products.
 - This product cannot store data.
Be careful that any data you are working on will be lost if the power supply is turned off.

●Product handling

*Handling

- Do not pull the lead wire forcefully. Do not lift or carry the product by pulling on the lead wire.
(Tensile strength: 35 N maximum for products with a connector conversion).
Hold the product by the body when handling.
Otherwise damage to the internal parts can result, causing malfunction or for the connector to be disconnected.

*Wiring

- Avoid repeatedly bending or stretching the lead wire, or placing a heavy load on them.
If the lead wire can move, fix it near the body of the product.
The recommended bend radius of the lead wire is 6 times the outside diameter of the sheath, or 33 times the outside diameter of the insulation material, whichever is larger.
Replace the damaged lead wire with a new one.
- Wire correctly.
Incorrect wiring can damage the product.
- Turn on the power switch after connecting the mobile battery to the product.
Otherwise damage to the internal parts can result, causing malfunction.
- Confirm proper insulation of wiring.
Poor insulation (interference from another circuit, poor insulation between terminals, etc.) can lead to excess voltage or current being applied to the product, causing damage.
- Keep wiring as short as possible to prevent interference from electromagnetic noise and surge voltage.

*Environment

- Do not use the product in an area that is exposed to corrosive gases, chemicals, sea water, water or steam.
Otherwise failure or malfunction can result.
- Do not use the product in an environment where the product is constantly exposed to water or oil splashes.
If the product is to be used in an environment containing oils or chemicals such as coolant or cleaning solvent, it may be adversely affected (damage, malfunction, or hardening of the lead wires).
- Do not use in an area where surges are generated.
If there is equipment which generates a large amount of surge (solenoid type lifter, high frequency induction furnace, motor, etc.) close to the product, this may cause deterioration or breakage of the internal circuit of the product. Avoid sources of surge generation and crossed lines.
- Check the specifications of the mobile battery used as a power source.
If the mobile battery is used at a temperature higher than the specifications, it may cause a malfunction, fire or burns.
Follow the instructions and precautions for use for the mobile battery.
- Do not use the product under excessive vibration or impact.
Otherwise failure or malfunction can result.
- Prevent foreign matter such as remnant of wires from entering the product.
Take measures for the remnants not to enter the product in order to prevent failure or malfunction.
- Do not use the product in an environment that is exposed to temperature cycle.
Heat cycles other than ordinary changes in temperature can adversely affect the inside of the product.
- Do not expose the product to direct sunlight.
If using in a location directly exposed to sunlight, shade the product from the sunlight.
Otherwise failure or malfunction can result.
- Keep within the specified ambient temperature range.
The ambient temperature range is 0 to 45 °C. Operation at low temperature (5 °C or less) may cause damage or operation failure due to frozen moisture in the air.
Protection against freezing is necessary.
Avoid sudden temperature change even within specified temperature.
- Do not operate close to a heat source, or in a location exposed to radiant heat.
Otherwise malfunction can result.

*Adjustment and Operation

- Turn on the power switch after connecting the pressure sensor.
- Do not short circuit the pressure sensor.
If the output of the pressure sensor is short-circuited, an error will be displayed, but there is a possibility that an overcurrent will flow and the product will be damaged.
- Do not press the setting buttons with a sharp pointed object.
It may damage the setting buttons.
- To reduce the measurement error in the environment where you are using the pressure sensor, warm up the product for 10 to 15 minutes.
The pressure sensor display will drift approximately $\pm 1\%$ immediately after and within 10 minutes of the power supply being turned on.
However, if the product is not operated for 10 minutes, the power supply to the sensor will be turned off due to power saving mode.
Therefore, set the power save mode to OFF or use button operations to prevent the power save mode from operating.
For details of this setting, refer to page 33 of this manual.
- Perform settings suitable for the operating conditions.
Incorrect setting can cause operation failure.
For details of each setting, refer to page 16 to 37 of this manual.
- Do not touch the LCD during operation.
The display can vary due to static electricity.
- If the pressure sensor output specification is a switch output, note that changing the set value will result in operation that differs from the set value indicated on the nameplate of the pressure sensor.

*Maintenance

- Remove the mobile battery power supply before maintenance.
There is a risk of unexpected malfunction.
- Perform regular maintenance and inspections.
There is a risk of unexpected malfunction.
- Do not use solvents such as benzene, thinner etc. to clean the product.
They could damage the surface of the body and erase the markings on the body.
Use a soft cloth to remove stains. For heavy stains, use a cloth soaked with diluted neutral detergent and fully squeezed, then wipe up the stains again with a dry cloth.

Model Indication and How to Order

PSE-ST-

└ Sensor lead wire

Symbol	Content
Nil	Without connector
L	Connector for discrete wires (D-LH03C)
S	M12-4pin socket connector (D-LH03B)

Summary of Product parts

Names of individual parts

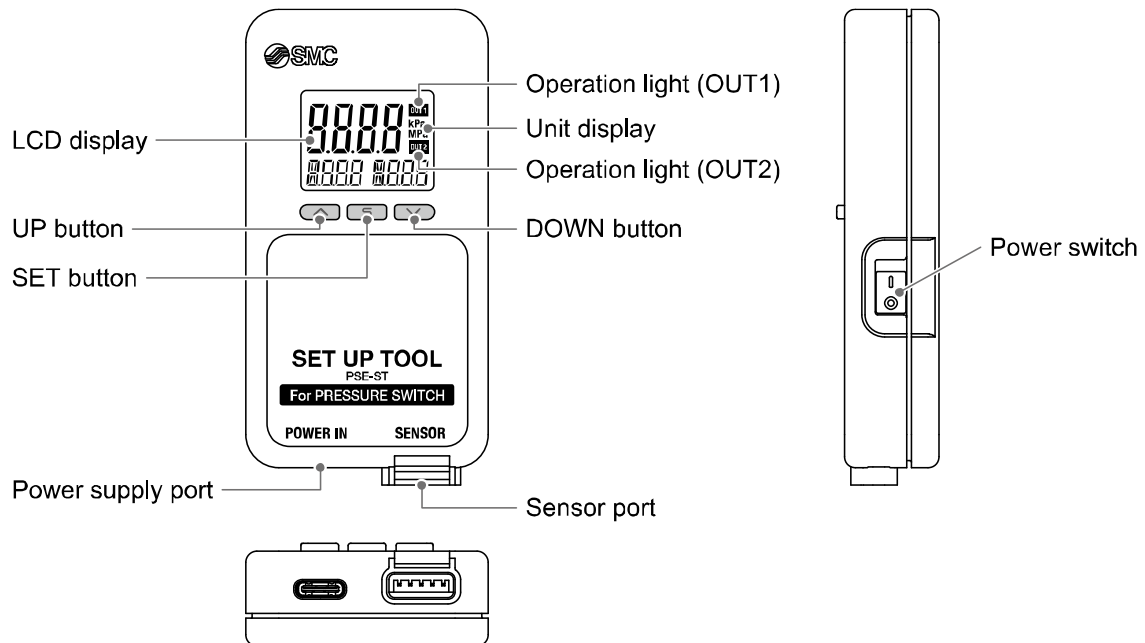

Operation light: Displays the switch operating condition.

LCD display: Displays the current status of pressure, setting mode, selected display units and error code.
The main display is normally a solid green colour, but when there is an error, it will turn red.
The indication for the sub display is orange.

UP button: Increases mode and ON/OFF set values.

DOWN button: Decreases mode and ON/OFF set values.

SET button: Press this button to change mode and to confirm settings.

Unit display: Indicates the units currently selected.

Power supply port: Port for connecting a mobile battery power supply. USB Type-C connector is compatible.
The mobile battery and cable to connect the mobile battery to this product should be prepared by the user.

Sensor port: Port for connecting the pressure sensor to be set up via the connector conversion parts.

Power switch: Switch to turn the product ON/OFF.

■ Definition and terminology

	Term	Definition
C	Chattering	The problem of the switch output turning ON and OFF repeatedly around the set value at high frequency due to the effect of pulsation.
	Copy function	A function to copy a pressure setting value and function setting.
D	Delay time	The setting time from when the signal of the connected pressure sensor reaches the set value, to when the ON-OFF output actually begins working. Delay time setting can prevent the output from chattering.
	Digital filter	Function to add digital filtering to the fluctuation in the input signal. Smooth the fluctuation of displayed value for sharp start up or fall of the pressure. When the function is used, digital filtering is reflected in the switch output ON/OFF. Output chattering or flicker in the measurement mode display can be reduced by setting the digital filter. The response time indicates when the set value is 90% in relation to the step input.
	Display colour	Indicates the colour of the digits on the digital display.
	Display resolving power	Indicate in how many the rated pressure range can be divided to display. (Example: When the value can be displayed down to 0.001 MPa for the product for 0 to 1 MPa, the resolution is 1/1000)
E	Error output	Switches the switch output to ON/OFF when an error is displayed. Refer to "List of output modes" on page 26 for operating conditions. Refer to "Error indication function" on page 45 for details of the errors.
	Error displayed	The code number displayed, identifying the error detected by the self-diagnosis function of the product. Refer to "Error indication function" on page 45 for details of the errors.

	Term	Definition
F	F.S. (full span/full scale)	Abbreviation of full span and full scale; difference between the minimum and maximum rated pressure values. means the maximum fluctuation range of the product rated value. For example, when the rated pressure range is -0.100 to 1.000 [MPa]: F.S. = 1.000 - (-0.100) = 1.100 [MPa] (Reference: 1%F.S. = 1.100 x 0.01 = 0.011 [MPa])
	Function selection mode	A mode in which setting of functions is performed. It is a separate menu from the pressure setting. If any function settings need to be changed from the factory default, each setting can be selected with "F*". The setting items are: pressure unit, output mode, output type, digital filter, measurement value fine adjustment, etc.
H	Hysteresis	Difference between the points at which the product is turned ON and OFF.
	Hysteresis mode	Refer to the "List of output modes" on page 26.
I	Insulation resistance	Insulation resistance of the product. The resistance between the electrical circuit and the case.
M	Measurement mode	Operating condition in which pressure is being detected and displayed, and the switch function is working.
	Measurement value fine adjustment (function)	Measurement pressure value can be adjusted within the range of $\pm 5\%$ R.D. ($\pm 5\%$ of displayed value). It is used if the true pressure value is known, or to eliminate differences between the displayed values of different instruments that are measuring the same pressure.
	Minimum setting unit	Indicates how precisely the pressure can be displayed or set.
N	Normal output	One of the switch output types. In hysteresis mode the switch output is turned ON when pressure equal to or greater than the switch output set value is detected. In window comparator mode, the switch output is turned ON when pressure between the switch output set values (P1L to P1H) is detected. (Refer to the "List of output modes" on page 26)
O	Operation light	A light that turns on when the switch output is ON.
	Operation mode	Either hysteresis mode or window comparator mode can be selected.
	Output style	The operation principle of the switch output. Normal output and reverse output can be selected. Please refer to the "List of output modes" on page 26 operating conditions.
P	Power saving function	This function cuts off the power supply to the sensor, causing the numerical display to disappear to reduce the current consumption.
	Pressure setting	The set pressure value that determines the point at which the product turns ON and OFF.

	Term	Definition
R	Rated pressure range	The pressure range within which the product will meet all published specifications. Values outside of this range can be set as long as they are within the set pressure range, but the specifications cannot be guaranteed.
	R.D.	Current read value For example, when the display value is 1.000[MPa], $\pm 5\%$ R.D. is $\pm 5\%$ of 1.000 [MPa], which becomes ± 0.05 [MPa]. When the display value is 0.800 [MPa], $\pm 5\%$ R.D. is $\pm 5\%$ of 0.800 [MPa], which becomes ± 0.04 [MPa].
	Resolution	Refer to "Display resolution".
	Reversed output	One of the switch output types. In hysteresis mode the switch output is turned ON when pressure less than or equal to the switch output set value is detected. In window comparator mode, the switch output is turned ON when pressure is outside the switch output set values (n1L to n1H) is detected. (Refer to the "List of output modes" on page 26)
S	Set pressure range	The pressure range that can be set for switch output.
	Switch output	Sometimes referred to as "ON-OFF output".
U	Units selection function	A function to change the units in which the measured pressure value is displayed. The display units can only be changed if the product is equipped this function. It is not possible to purchase the product with this function if the product is used in Japan. The product for Japan is displayed in SI only.
W	Window comparator mode	An operating mode in which the switch output is turned on and off depending on whether the flow is inside or outside the range of two set values. (Refer to the "List of output modes" on page 26)
	Withstand voltage	A measure of the product's resistance to a voltage applied between the electrical circuit and case. Durability in withstanding voltage. The product may be damaged if a voltage over this value is applied. (The withstand voltage is not the supply voltage used to power the product.)
Z	Zero-clear function	This function to adjust the displayed pressure to zero.

Wiring

○Wiring connections

- Connections should be made with the power supply turned off.
- Use a separate route for the product wiring and any power or high voltage wiring. Otherwise, malfunction may result due to noise.

○How to use the connector

Connector conversion parts attachment/detachment

- When connecting the connector conversion parts, insert it straight onto the pins, holding the lever and connector body, and lock the connector by pushing the lever hook into the concave groove on the housing.
- To detach the connector, remove the hook from the groove by pressing the lever down, and pull the connector straight out.

*: A mobile battery and cable to connect the mobile battery to this product must be provided by the user.

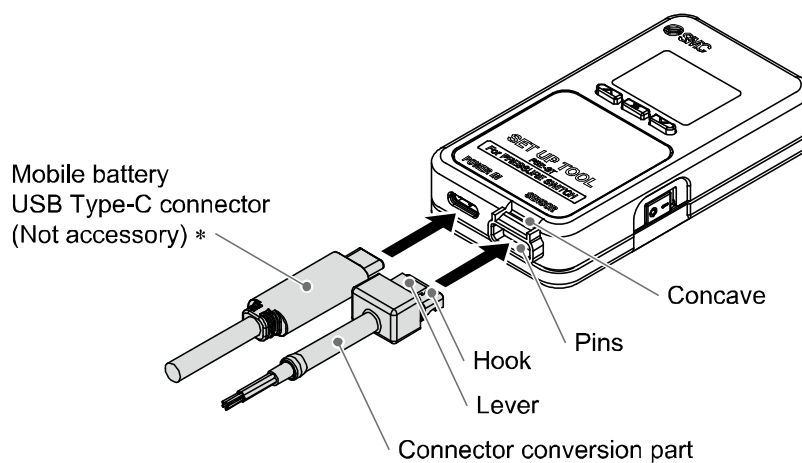

Connector conversion parts pin layout

- Discrete wires

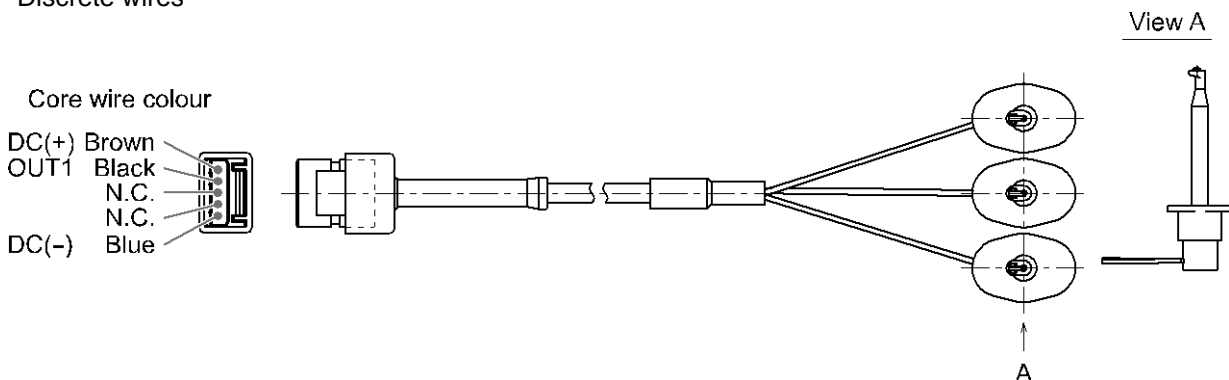

Wiring		Connector for discrete wires	
Connector pin number	Wire colour	Connector colour	Description
1	Blue	Blue	DC(-)
2	-	-	N.C.
3	-	-	N.C.
4	Black	Black	OUT1
5	Brown	Red	DC(+)

•M12-4pin connector

Core wire colour

DC(+) Brown
 OUT1 Black
 N.C. N.C.
 DC(-) Blue

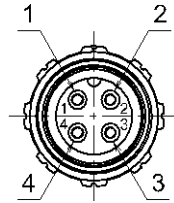
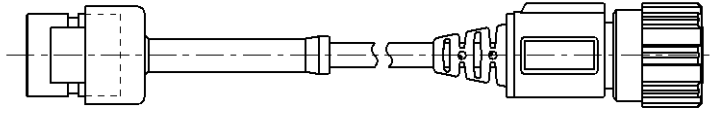

Wiring			Description
Connector pin number	Wire colour	M12 Connector pin number	
1	Blue	3	DC(-)
2	-	-	N.C.
3	-	-	N.C.
4	Black	4	OUT1
5	Brown	1	DC(+)

○Internal circuit and wiring example

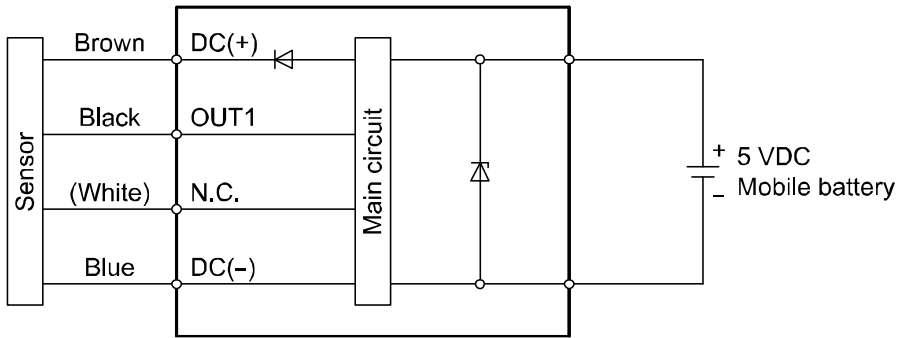

Outline of Settings

Power is supplied



The product code is displayed for approximately 1 sec. after supplying power. After that, measurement mode is displayed.



[Measurement mode]

Detects the pressure after power is supplied, and indicates the display and switch operating status. This is the basic mode; other modes should be selected for set-point changes and other function settings.

Measurement mode screen

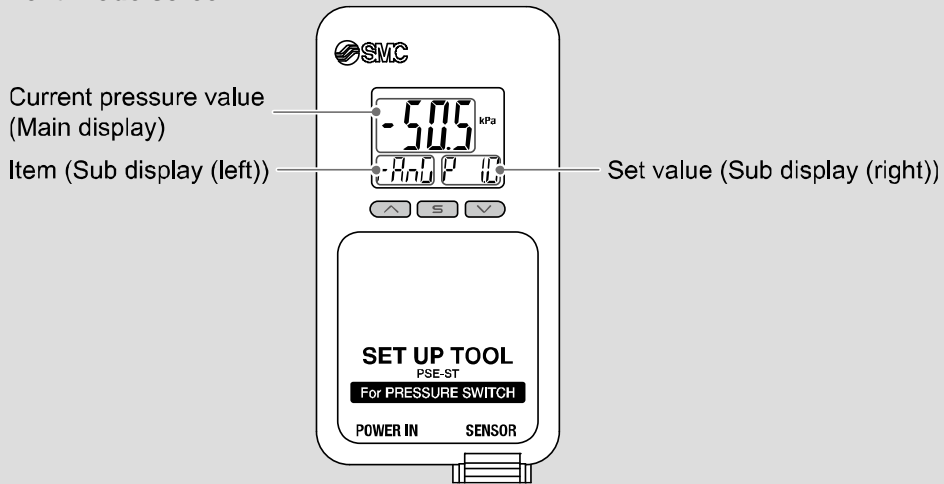

If the pressure sensor is not connected, [- - -] will be displayed on the main display and sub display (right).

Sub display

In measurement mode, the display of the sub display can be temporarily changed by pressing the UP or DOWN buttons.

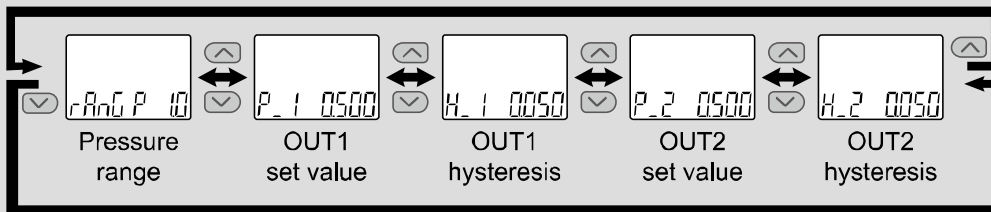

For information on pressure ranges, please refer to "Pressure range display" (page 17).



When displaying other than the pressure range, press the SET button once.



Press the SET button 2 sec. or longer.

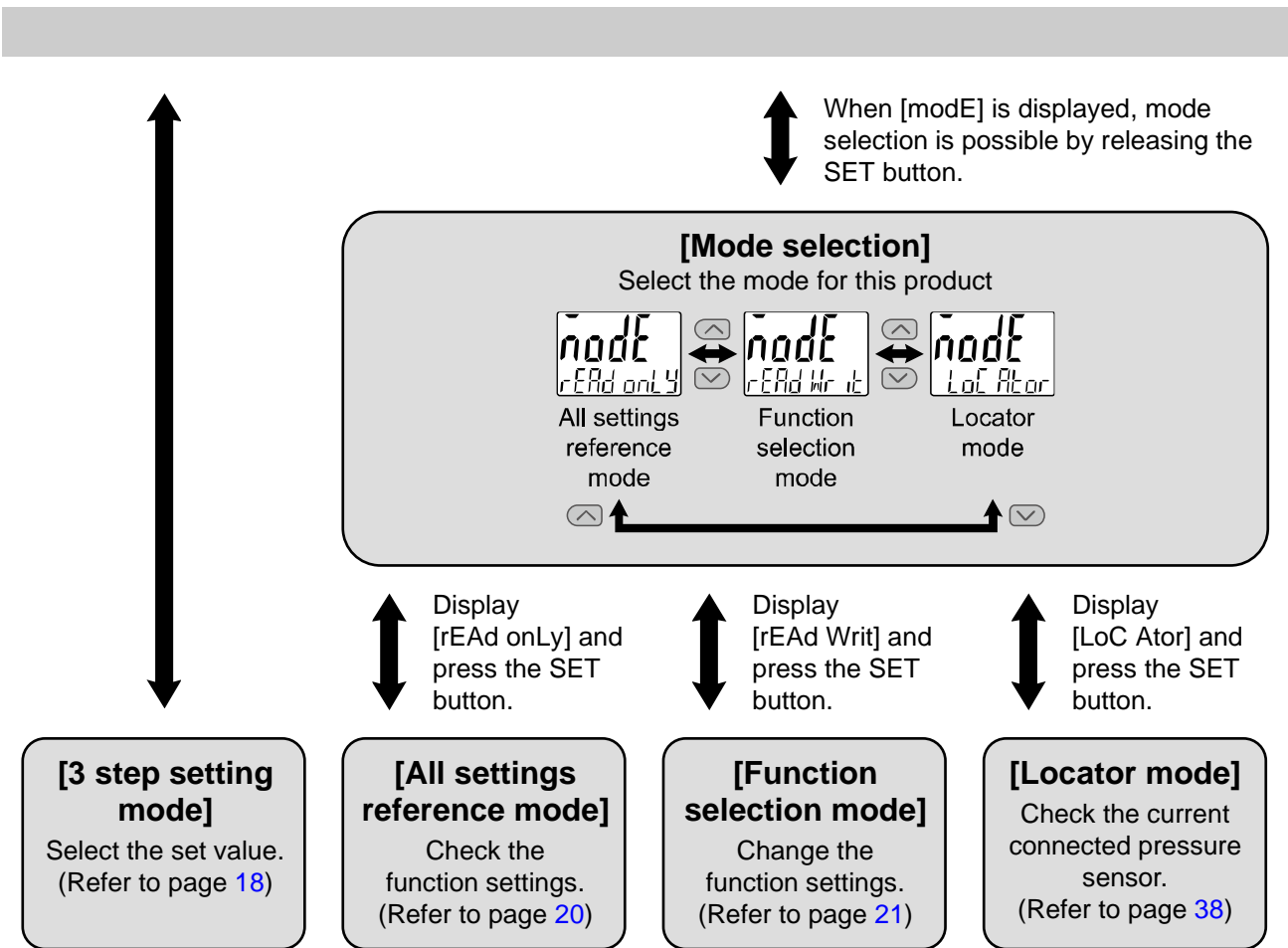

- *: The outputs will continue to operate during setting.
- *: If a button operation is not performed for a certain time during the setting, the display will flash.
(This is to prevent the setting from remaining incomplete if, for instance, an operator were to leave during setting.)
- *: 3 step setting mode and function selection mode settings are reflected on each other.
- *: If the SET button is pressed for 2 seconds or longer in any mode, the product moves to measurement mode.

●Pressure range display

Pressure range	Rated pressure	Applicable sensor	Display range
Negative pressure	-101 kPa	PSE541	- 100
Compound pressure	±100 kPa	PSE543 PSE573	F 100
Positive pressure	500 kPa	PSE574	P 05
	1 MPa	PSE540 PSE570	P 10
High pressure	2 MPa	PSE575	P 20
	5 MPa	PSE576	P 50
	10 MPa	PSE577	P 100

3 Step Setting Mode

3 step setting mode

In this mode, the set values can be input in just 3 steps.

Use this mode if the product is to be used straight away, after changing only the set values.

(The current pressure value is displayed on the main display.)

<Operation>

[3 step setting mode (hysteresis mode)]

In the 3 step setting mode, the set value (P_1 or n_1, P_2 or n_2) and hysteresis (H_1, H_2) can be changed. Set the items on the sub display (set value or hysteresis) with UP or DOWN button. When changing the set value, follow the operation below. The hysteresis setting can be changed in the same way.

- (1) Press the SET button once when the item to be changed is displayed on the sub display.
The set value on the sub display (right) will start flashing.

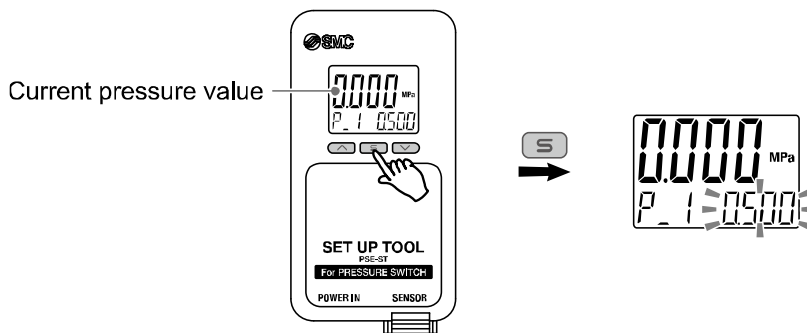

- (2) Press the UP or DOWN button to change the set value.
The set value can be increased with UP button and can be reduced with DOWN button.

• Press the UP button once to increase the value by one digit, press and hold to continuously increase.

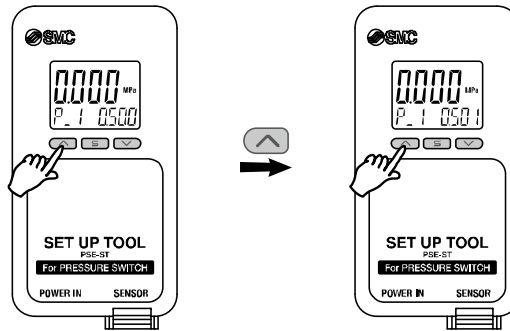

• Press the UP button once to reduce the value by one digit, press and hold to continuously reduce.

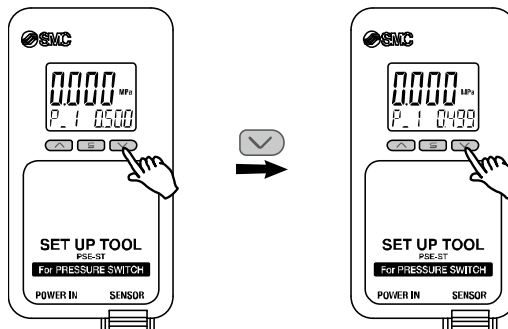

•When the UP and DOWN buttons are pressed and held simultaneously for 1 second or longer, the set value is displayed as [- - -], and the set value will be the same as the current pressure value automatically (snap shot function (Refer to page 39)). Afterwards, it is possible to adjust the value by pressing the UP or DOWN button.

(3) Press the SET button to return to measurement mode

The product turns on within a set pressure range (OUT1: from P1L to P1H, OUT2: from P2L to P2H) during window comparator mode. Set P1L/P2L, the lower limit of the switch operation, and P1H/P2H, the upper limit of the switch operation and WH1/WH2 (hysteresis) following the instructions given on page 18. (When reversed output is selected, the sub display (left) shows [n1L]/[n2L] and [n1H]/[n2H].) Please refer to the "List of output modes" on page 26 for the relationship between the set values and operation.

*: Setting of the normal/reverse output switching and hysteresis/window comparator mode switching are performed with the function selection mode [F 1] Setting of OUT1, [F 2] Setting of OUT2.

All Settings Reference Mode

■ All settings reference mode

In mode selection, when [rEAd onLy] is displayed, press the SET button to display [F 0].
 [F□□] displays the mode for displaying the parameters set for each function.
 The settings cannot be changed.

The following parameters can be confirmed.

[F 0]: Display unit, switch output specification switching function

[F 1]: Setting of OUT1

[F 2]: Setting of OUT2

[F 3]: Digital filter setting

[F 6]: Fine adjustment of measurement value

[F14]: Zero cut-off setting

*: In [F 6] [F14], the [F□□] is not displayed, but [F 6]: adjusted pressure value, and [F14]: zero-cut pressure value are displayed.

Press and hold the SET button for 2 seconds or longer in all setting reference modes to return to measurement mode.

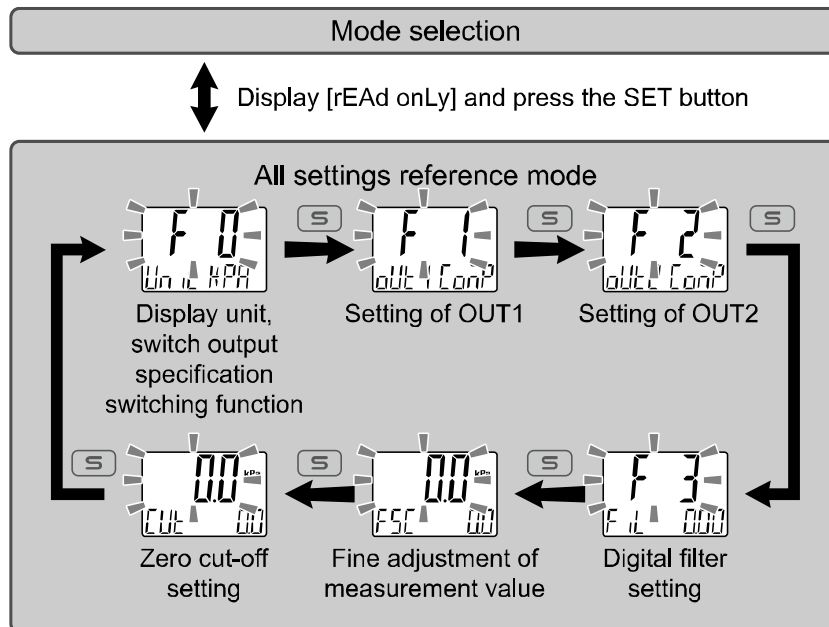

Function Selection Mode

■ Function selection mode

In mode selection, When [rEAd Writ] is displayed, press the SET button to display [F 0].

Select to display the function to be changed [F□□]. Press and hold the SET button for 2 seconds or longer in function selection mode to return to measurement mode.

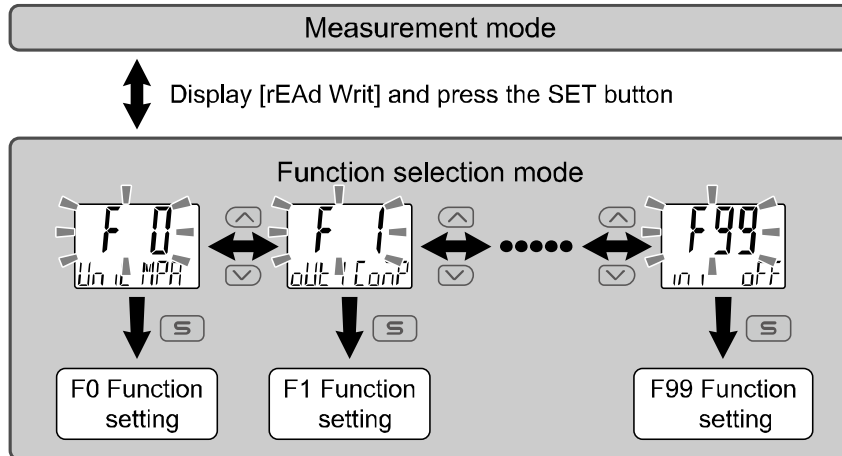

*: Depending on the pressure sensor connected, not all the functions are available. If a function is not available or selected due to configuration of other functions, [- - -] is displayed on the sub display (right).

■ Default setting

As this product is used to display and change the settings of the connected pressure sensor, there are no default settings for this product.

■ [F 0] Display unit, switch output specification switching function

● Available display unit and minimum set value

Pressure range	Rated pressure	Applicable sensor	MPa	kPa
Negative pressure	-101 kPa	PSE541	0.001	0.1
Compound pressure	±100 kPa	PSE543 PSE573	0.001	0.1
Positive pressure	500 kPa	PSE574	0.001	1
	1 MPa	PSE540 PSE570	0.001	1
High pressure	2 MPa	PSE575	0.001	1
	5 MPa	PSE576	0.01	10
	10 MPa	PSE577	0.01	-

<Operation>

Press the UP or DOWN button in function selection mode to display [F 0].

Press the SET button. ↓ Move on to display unit setting.

Display unit setting

Press the UP or DOWN button to select the display unit.

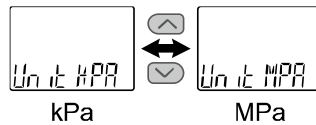

*: The unit that can be displayed is different depending on the pressure range. (Refer to page 22)

Press the SET button to set. ↓ Move on to switch output NPN/PNP specification switching setting.

Switch output NPN/PNP specification switching setting

The switch output of this product can be switched to NPN or PNP output in accordance with the user device construction.

Press the UP or DOWN button to select switch output specification.

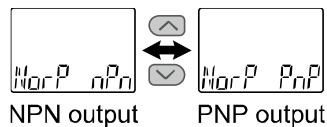

Press the SET button to set. ↓ Return to function selection mode.

[F 0] Display unit, switch output specification switching function setting is completed.

■[F 1] Setting of OUT1

Set the output mode of OUT1.

Output turns on when the pressure is greater than the set value.

Please refer to the "List of output modes" on page 26 for the relationship between the set items and operation.

<Operation>

Press the UP or DOWN button in function selection mode to display [F 1].

Press the SET button. ↓ Move on to output mode setting.

Output mode setting

Press the UP or DOWN button to select the output mode.

Press the SET button to set. ↓ Move on to comparator output setting.

Comparator output setting

Press the UP or DOWN button to select the comparator output.

[Err] Error output is selected.
Press the SET button to move on to reversed output setting.

Press the SET button to set. ↓ Move on to reversed output setting.

Reversed output setting

Press the UP or DOWN button to select the reversed output.

[oFF] Switch output OFF is selected.
Press the SET button to set.

Return to function selection mode.

Press the SET button to set. ↓ Move on to pressure setting.

↓

Pressure setting

Set the pressure based on the setting method on page 18.



Hysteresis mode: [P_1]
Window comparator mode: [P1L] [P1H]
"P" is changed to "n" as [P_1] → [n_1] when reversed output is selected.
The snap shot function can be used. (Refer to page 39)

Press the SET button to set. ↓ Move on to hysteresis setting.

Hysteresis setting

Set the hysteresis based on the setting method on page 18.



Hysteresis mode: [H_1]
Window comparator mode: [WH1]
The snap shot function can be used. (Refer to page 39)

Press the SET button to set. ↓ Move on to ON delay time setting.

ON delay time setting

Press the UP or DOWN button to adjust the set value.
If the button is held down, the value will continuously change.
(Holding down the button will increase the amount of change in the value.)



Press the SET button to set. ↓ Move on to OFF delay time setting.

OFF delay time setting

Press the UP or DOWN button to adjust the set value.
If the button is held down, the value will continuously change.
(Holding down the button will increase the amount of change in the value.)



■
Press the SET button to set.

Return to function selection mode.

↓

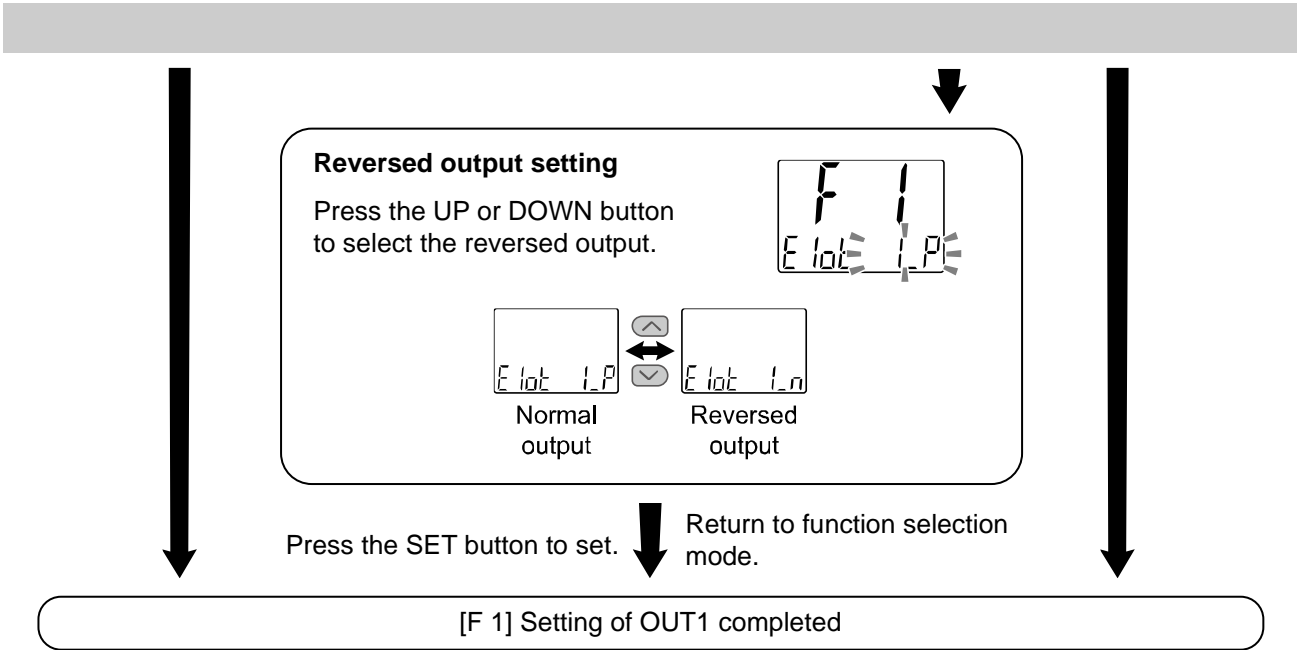

*1: Selected item becomes valid after pressing the SET button.

*2: After enabling the setting by pressing the SET button, it is possible to return to the measurement mode by keeping pressing the SET button for 2 seconds or longer.

•List of output modes

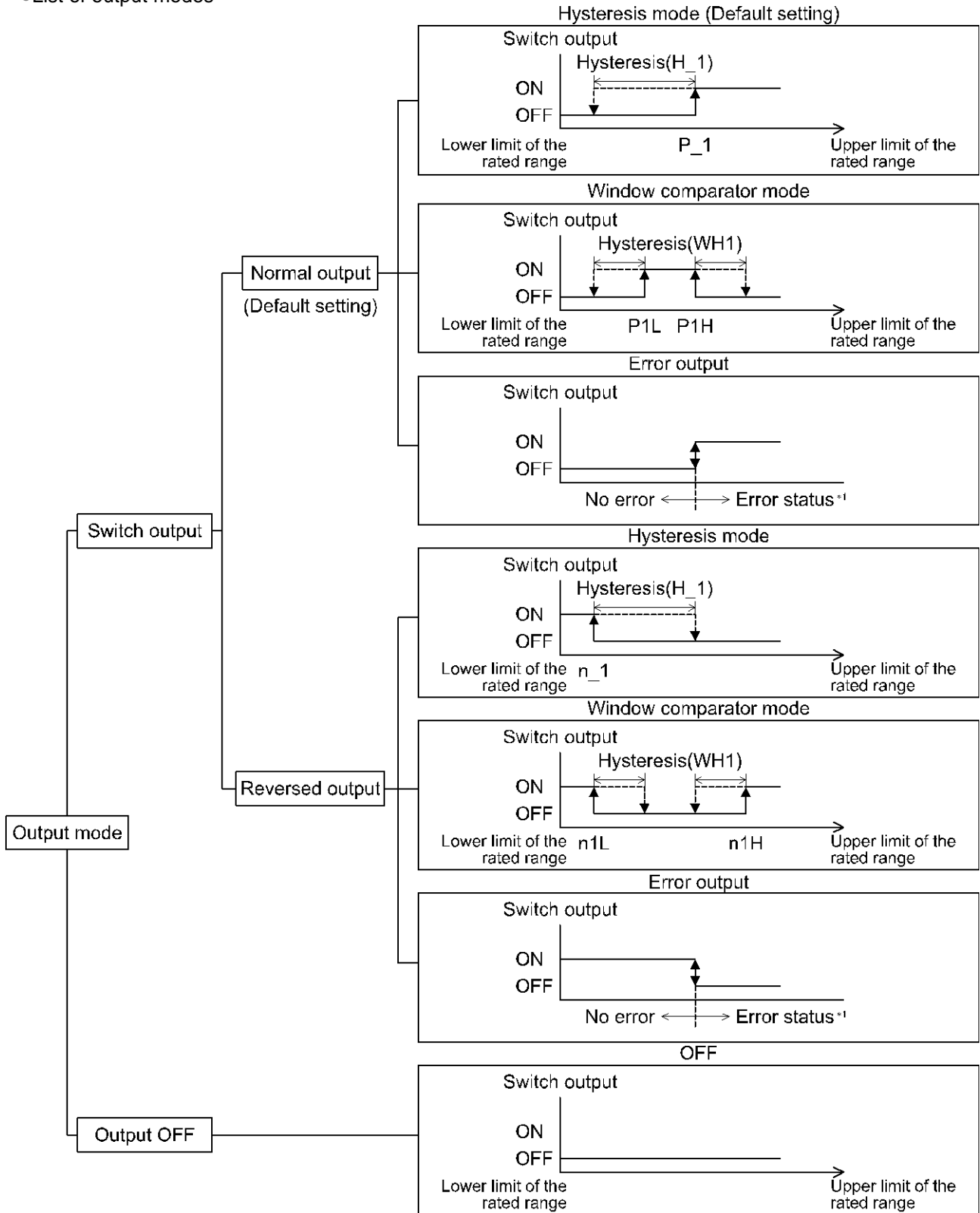

If the point at which the switch output changes is outside of the set pressure range due to the selection of normal or reversed output, the hysteresis value is automatically adjusted.

*1: For the error codes, please refer to the "Device Status Parameters" listed in the operation manual for the connected pressure sensor.

*: The figure above shows an operation at OUT 1. For OUT2, all "1" in the figure will be changed to "2". (e.g.) $P_1 \rightarrow P_2$

■[F 2] Setting of OUT2

Set the output mode of OUT2.

Output turns on when the pressure is greater than the set value.

Please refer to the "List of output modes" on page 26 for the relationship between the set items and operation.

<Operation>

Press the UP or DOWN button in function selection mode to display [F 2].

Press the SET button. ↓ Move on to output mode setting.

Output mode setting

Press the UP or DOWN button to select the output mode.



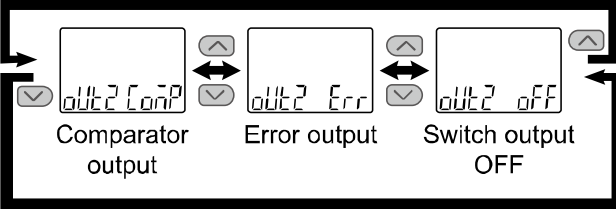

Press the SET button to set. ↓ Move on to comparator output setting.

Comparator output setting

Press the UP or DOWN button to select the comparator output.



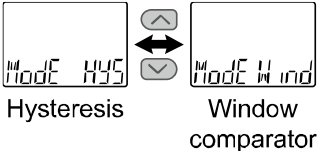

[Err] Error output is selected.
Press the SET button to move on to reversed output setting.

Press the SET button to set. ↓ Move on to reversed output setting.

Reversed output setting

Press the UP or DOWN button to select the reversed output.



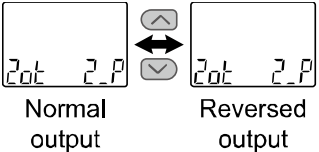

[oFF] Switch output OFF is selected.
Press the SET button to set.

Return to function selection mode.

Press the SET button to set. ↓ Move on to pressure setting.

Pressure setting

Set the pressure based on the setting method on page 18.

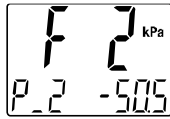

Hysteresis mode: [P_2]
Window comparator mode: [P2L] [P2H]
"P" is changed to "n" as [P_2] → [n_2] when reversed output is selected.
The snap shot function can be used. (Refer to page 39)

Press the SET button to set. ↓ Move on to hysteresis setting.

Hysteresis setting

Set the hysteresis based on the setting method on page 18.



Hysteresis mode: [H_2]
Window comparator mode: [WH2]
The snap shot function can be used. (Refer to page 39)

Press the SET button to set. ↓ Move on to ON delay time setting.

ON delay time setting

Press the UP or DOWN button to adjust the set value.
If the button is held down, the value will continuously change.
(Holding down the button will increase the amount of change in the value.)



Press the SET button to set. ↓ Move on to OFF delay time setting.

OFF delay time setting

Press the UP or DOWN button to adjust the set value.
If the button is held down, the value will continuously change.
(Holding down the button will increase the amount of change in the value.)



■
Press the SET button to set.

Return to function selection mode.



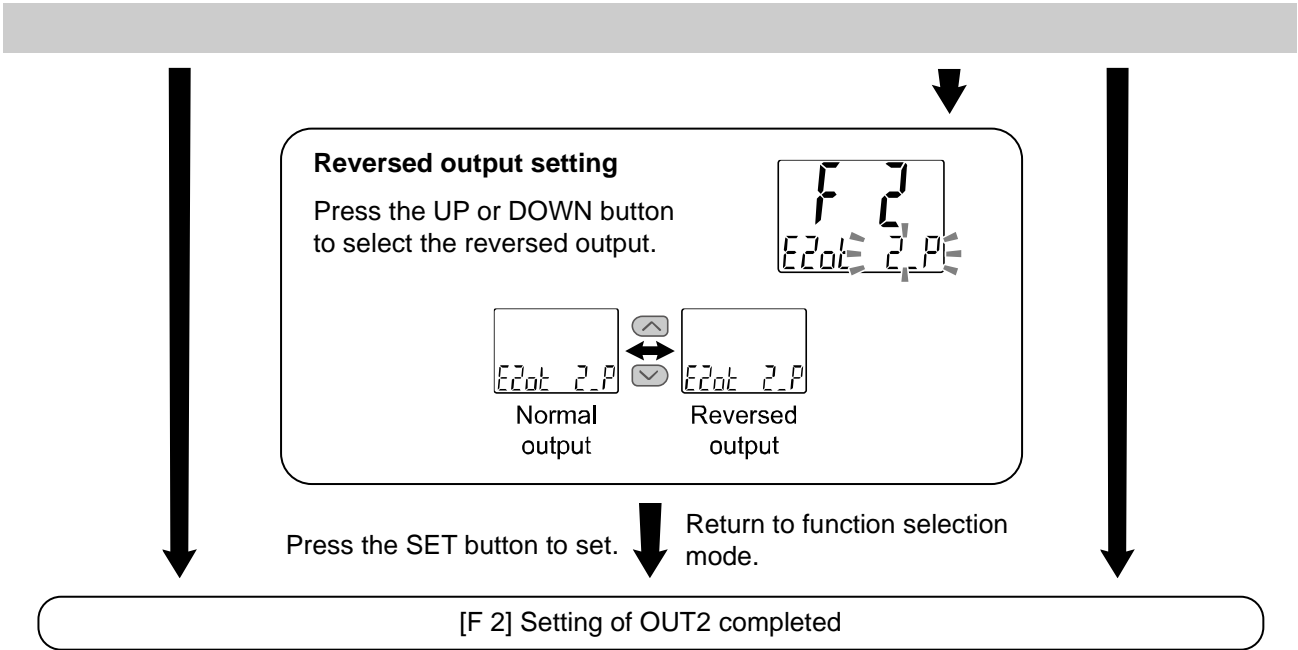

*1: Selected item becomes valid after pressing the SET button.

*2: After enabling the setting by pressing the SET button, it is possible to return to the measurement mode by keeping pressing the SET button for 2 seconds or longer.

■[F 3] Digital filter setting

The digital filter can be selected to filter the pressure measurement.
Output chattering or flicker in the measurement mode display can be reduced by setting the digital filter.
The Digital filter can be set in 0.01 sec. increments in the range of 0.00 to 30.00 sec.

<Operation>

Press the UP or DOWN button in function selection mode to display [F 3].

Press the SET button. ↓ Move on to digital filter setting.

Digital filter setting

Press the UP or DOWN button to change the digital filter.

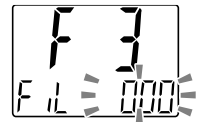

Press the SET button to set. ↓ Return to function selection mode.

[F 3] Digital filter setting completed

*1: Each set value is a guideline for 90% response time.

*2: Both the switch output and pressure display are affected. When only switch output needs to be affected, select the delay time setting. (page 24 and 28)

■[F 6] Fine adjustment of measurement value

This function is used to manually perform a fine adjustment of the pressure measurement value. Pressure can be adjusted in the range of $\pm 5\%$ R.D.

<Operation>

Press the UP or DOWN button in function selection mode to display [F 6].

Press the SET button. ↓ Move on to fine adjustment of measurement value.

Fine adjustment of measurement value

Press the UP or DOWN button to change the adjustment rate.

When the adjustment rate is changed, the pressure value after the adjustment will be displayed on the main display.

Pressure after adjustment



Adjustment rate

Press the SET button to set. ↓ Return to function selection mode.

[F 6] Fine adjustment of measurement value completed

■[F14] Zero cut-off setting

When the pressure display value is close to zero, the product rounds the value and zero will be displayed. The zero cut-off range is 0.0 to 10.0% F.S., and can be set in 0.1% F.S. increments. This setting will also be reflected in the output.

<Operation>

Press the UP or DOWN button in function selection mode to display [F14].

Press the SET button. ↓ Move on to select zero cut-off setting.

Select zero cut-off setting

Press the UP or DOWN button to select the value of zero cut-off.

The value displayed on the main display is the zero-cut pressure value. *2

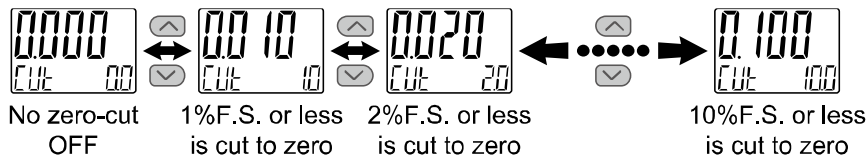

*1: The display above is an example of when [MPa] is selected for the PSE540 (1 MPa range) with the unit selection function.

*2: When the actual pressure is less than the displayed value in the upper line, zero will be displayed.

Example: 1 MPa range $P_1 = 0.015$ [MPa], $H_1 = 0.01$ [MPa], zero cut-off 1.0%

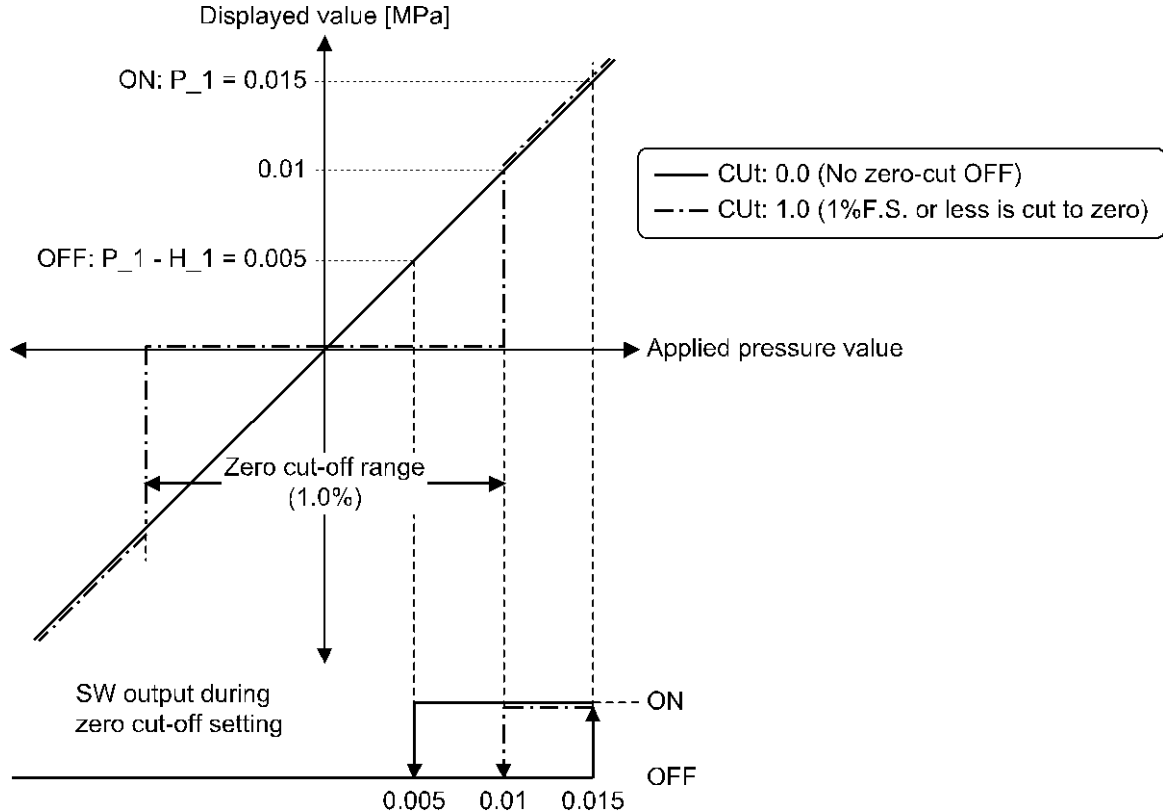

Press the SET button to set. ↓ Return to function selection mode.

[F14] Zero cut-off setting completed

■[F94] Other function settings

The power saving function and operation light target can be selected.

Power saving function: If the button is not operated for 10 minutes, this product will switch to a mode that reduces power consumption.

Operation light target selection: When setting PSE54#-L, the OUT2 operation light can be linked to the process data.

<Operation>

Press the UP or DOWN button in function selection mode to display [F94].

Press the SET button. ↓ Move on to power saving function setting.

Power saving function setting

Press the UP or DOWN button to select the power saving function ON/OFF.

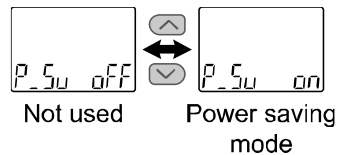
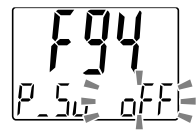

Press the SET button. ↓ Move on to operation light target setting.

Operation light target setting

Press the UP or DOWN button to select the operation light target.

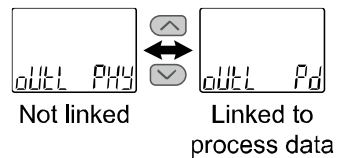

*: If a sensor with a switch output specification is connected, [- -] will be displayed and it cannot be set.

Press the SET button to set. ↓ Return to function selection mode.

[F94] Other function settings completed

■[F96] Measurement process data display, SW output point display

- Display the current process data of the connected sensor.
- Display the number of output points of the connected sensor.

<Operation>

Press the UP or DOWN button in function selection mode to display [F96].

Press the SET button. ↓ Move on to measurement process data display. (Bit 16 to 31)

Process data (Bit 16 to 31) display

Display the pressure measurement value in hexadecimal.



Press the SET button. ↓ Move on to measurement process data display. (Bit 0 to 15)

Process data (Bit 0 to 15) display

Display the switch output (Bit 0 to 1), diagnostics (measurement) (Bit 8), diagnostics (Error) (Bit 14, 15) in hexadecimal.



Press the SET button. ↓ Move on to SW output point display.

SW output point display

Display the SW output point



Press the SET button to set. ↓ Return to function selection mode.

[F96] Measurement process data display, SW output point display completed

■[F97] Selection of copy function

The set values of a sensor can be copied. Copy is possible when the pressure range and output specifications are the same.

<Operation>

In this section, the pressure sensor that is the source of the copy is referred to as pressure sensor (A), and the pressure sensor that is the destination of the copy is referred to as pressure sensor (B) and (C). Connect the pressure sensor (A) that will be the source of the copy to this product. Press the UP or DOWN button in function selection mode to display [F97].

Press the SET button. ↓ Move on to selection of copy function.

Selection of copy function

Press the UP or DOWN button to select the copy function.

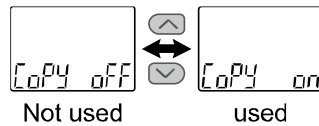

*: If the product has not been connected to a pressure sensor since it was turned on, [- -] will be displayed as there is no data to copy.

[oFF] (not used) is selected
Press the SET button to set.

Return to function selection mode.

[on] (used) is selected

Move on to copy ready status.*¹

Remove pressure sensor (A) and connect pressure sensor (B).

Copy the settings of pressure sensor (A) to pressure sensor (B)

Copy is complete, [Copy Fin] will be displayed on the sub display.*²

The settings of pressure sensor (A) have been copied to pressure sensor (B)

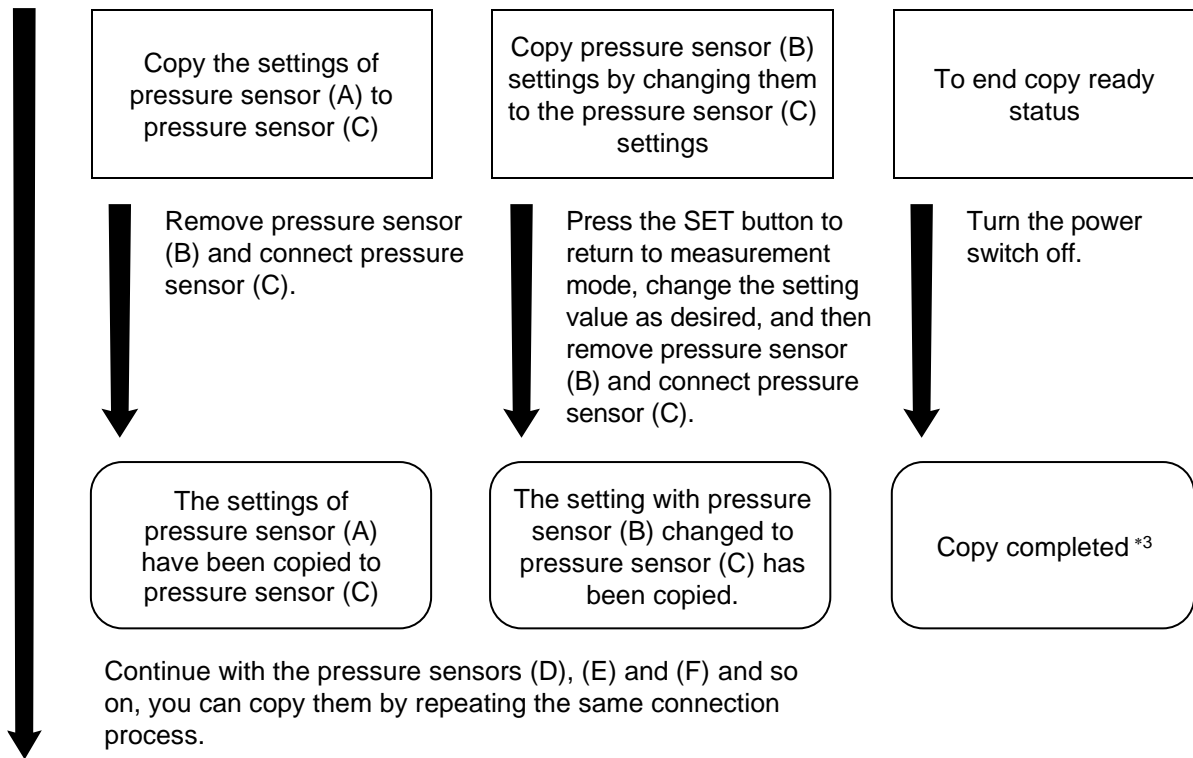

[F97] Copy function setting completed

- *1: Copy ready status is a state in which copying starts automatically when a pressure sensor is connected.
- *2: If [Copy Err] is displayed on the sub display, the copy has failed, so please check the wiring or the specifications of the connected sensor.
- *3: The copy preparation state will not be cancelled unless the power switch is turned off, or it is reset or set [oFF] (not used) in the copy function selection.

■ [F99] Reset to initial settings

If the pressure sensor settings are uncertain, the initial values can be restored.

If the output specification of the pressure sensor is switch output, please note that changing the set value will result in operation that differs from the set value indicated on the nameplate of the pressure sensor.

<Operation>

Press the UP or DOWN button in function selection mode to display [F99].

Press the SET button. ↓ Move on to reset to initial settings.

Reset to initial settings

Press the UP or DOWN button to display [ON], then press the SET and DOWN buttons simultaneously for 5 second or longer.

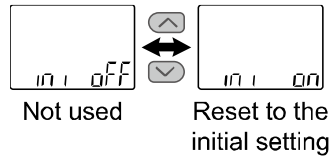

[oFF] (not used) is selected.
Press the SET button to set.

Return to function selection mode.

All settings are returned to the initial values. Return to function selection mode. (Reload settings)

[F99] Reset to initial settings completed

● Initial setting of each pressure sensor

Applicable pressure sensor	PSE541-L	PSE543-L PSE573-L2	PSE574-L2	PSE540-L PSE570-L2	PSE575-L2	PSE576-L2	PSE577-L2
Pressure range	Negative pressure	Compound pressure	Positive pressure		High pressure		
Display units	kPa	kPa	kPa	MPa	MPa	MPa	MPa
Switch output specification	PNP						
Output mode setting	Comparator output						
Comparator output setting	Hysteresis						
Reversed output setting	Normal output						
Pressure setting	-50.0	50.0	250	0.500	1.000	2.50	5.00
Hysteresis setting	5.0	5.0	25	0.050	0.100	0.25	0.50
ON delay time setting	0.00						
OFF delay time setting	0.00						
Digital filter setting	0.00						
Fine adjustment of measurement value	0.0						
Zero cut-off setting	0.0						

*: Be careful as this is not the default setting.

*: OUT1 and OUT2 are the same setting.

Locator Mode

■Locator mode

This is the mode for setting the start and end of the locator function.

Press and hold the SET button for 2 seconds or longer in locator mode to return to measurement mode.

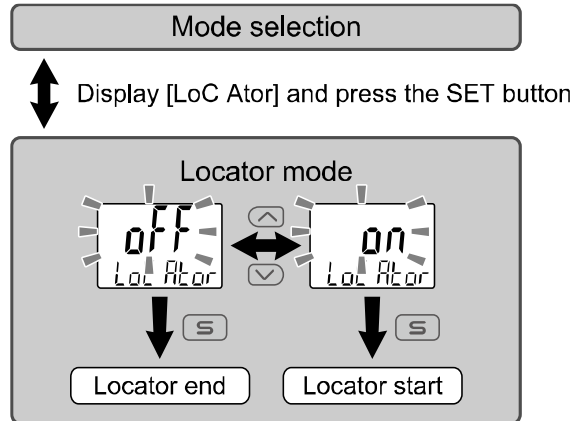

○Locator function

The locator function can be used to make the operation indicator light of the connected pressure sensor to flash (for 10 minutes). This allows the visual check of which pressure sensor is connected to the product, even after the pressure sensor has been installed in the equipment.

If the connected pressure sensor is changed while the locator function is turned on, the operation light on the newly connected pressure sensor will flash.

With the locator function turned on, press the SET button for 2 seconds or longer to return to measurement mode, and the setting values can be changed while the locator function is still on.

To disable the locator function, either turn the product off or turn the power off and then back on again.

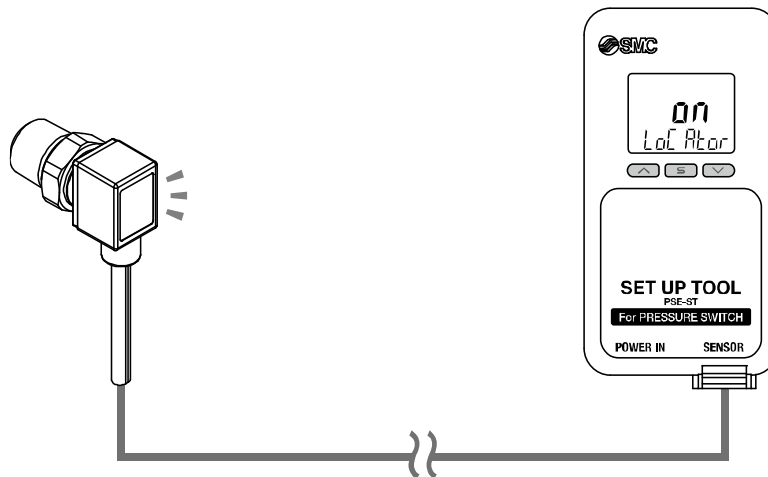

Other Settings

○ Snap shot function

The current pressure value can be stored to the switch output ON/OFF set point.

When the items of the sub display (left) are selected in 3 step setting mode or function selection mode, ([F 1] Setting of OUT1, [F 2] Setting of OUT2), by pressing the UP and DOWN buttons simultaneously for 1 second or longer, the value of the sub display (right) indicates [- - -], and the values corresponding to the current pressure values are automatically displayed.

Output mode	Configurable items	Sub display (left)	Snap shot function
Hysteresis mode	Set value	$P_{-1} (n_{-1}) / P_{-2} (n_{-2})$	○
	Hysteresis	H_{-1} / H_{-2}	○
Window comparator mode	Set value	$P_{1L} (n_{1L}), P_{1H} (n_{1H})$ $P_{2L} (n_{2L}), P_{2H} (n_{2H})$	○
	Hysteresis	H_{1L} / H_{1H} H_{2L} / H_{2H}	×

• Set value

The value is set to the same value as the display value (current pressure value).

(There is a range which cannot be set to the current pressure depending on the hysteresis. In that case, the value is set to the closest value.)

• Hysteresis

The hysteresis is calculated from the equation below and set.

Normal output: (set value) - (current pressure value) Reverse output: (current pressure value) - (set value)

If the calculation result becomes 0 or less, [Err] is displayed on the sub display (right) and the set value is not changed.

Afterwards, it is possible to adjust the value by pressing the UP or DOWN button.

○ Zero-clear function

The displayed value can be adjusted to zero if the pressure being measured is within $\pm 7\%$ F.S ($\pm 3.5\%$ F.S. for compound pressure) of the zero point set at the time of default settings.

(The zero clear range varies by $\pm 1\%$ F.S. due to variation between individual products.)

In measurement mode, when the UP and DOWN buttons are pressed for 1 second or longer simultaneously, the main display will indicate the display below, and will be reset to zero. The display returns to measurement mode automatically.

• Display during zero-clear

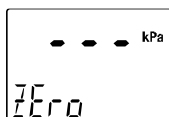

Troubleshooting

○ Troubleshooting

When any failure occurs with this product, the following chart can be used to identify the cause of the failure. If a cause applicable to the troubles cannot be identified and normal operation is recovered by replacement with a new product, this indicates that the product itself was faulty. Problems with the product may be due to the operating environment (installation etc). Please consult SMC.

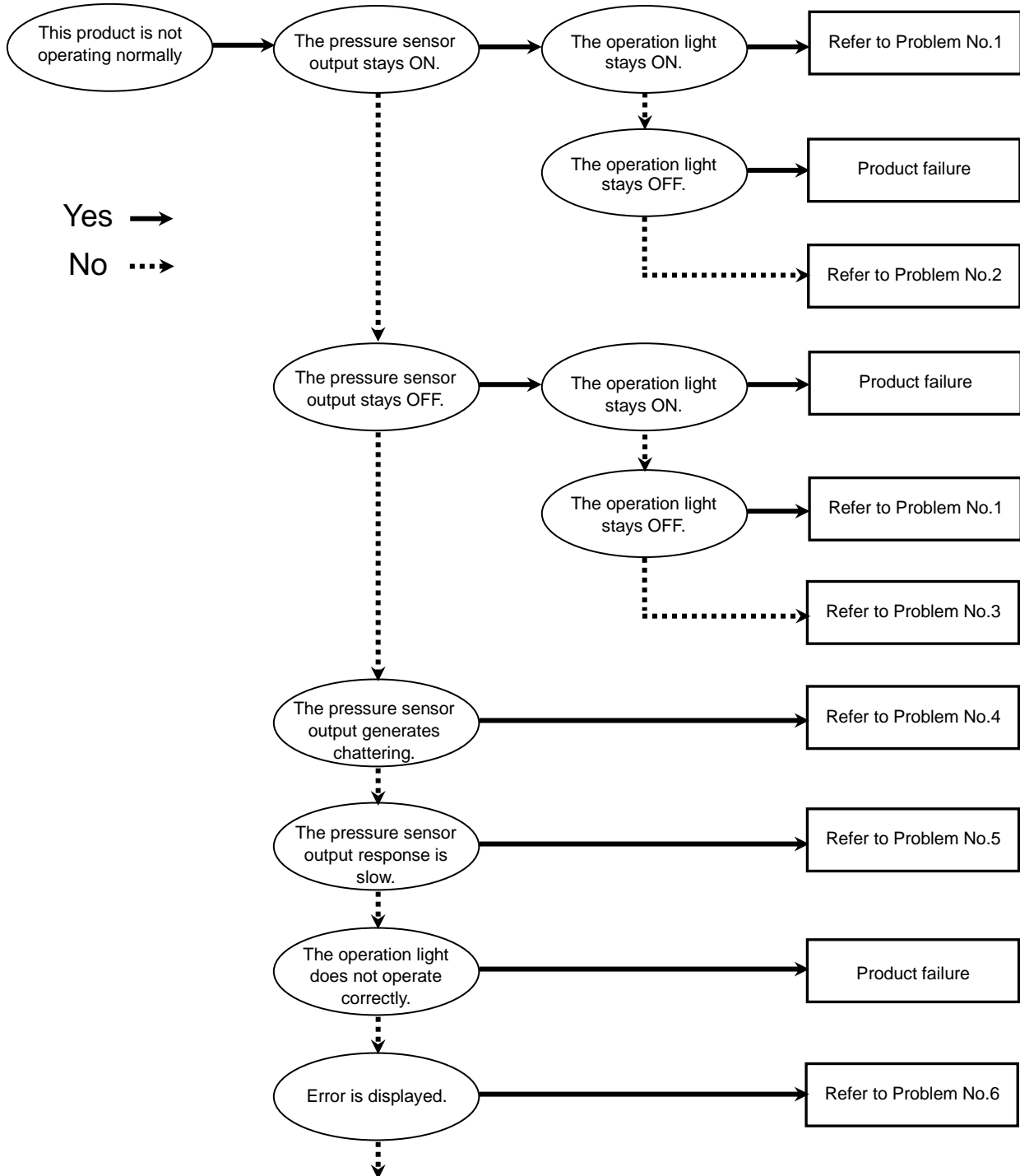

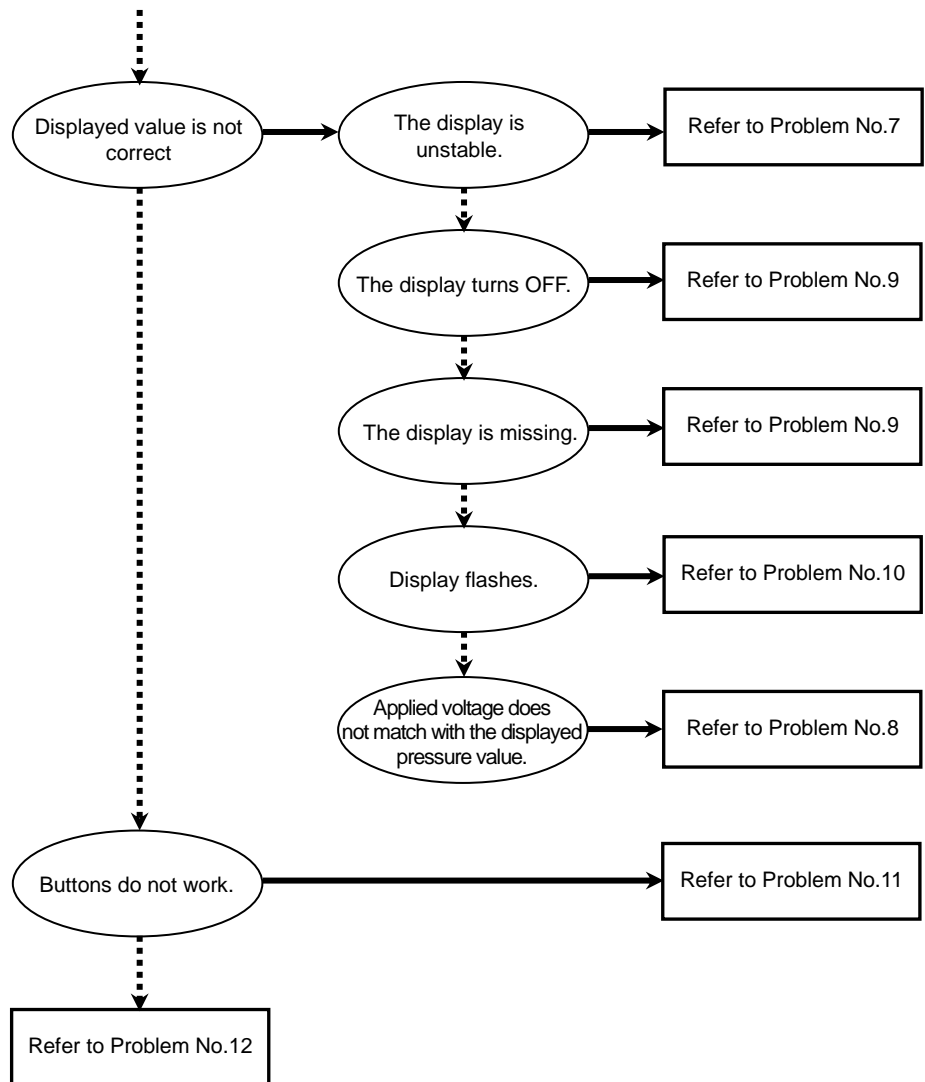

○Troubleshooting list







Problem No.	Problem	Problem possible causes	Investigation method	Countermeasures
1	<ul style="list-style-type: none"> •The pressure sensor output stays ON. The operation light stays ON. •The pressure sensor output stays OFF. The operation light stays OFF. 	Incorrect pressure setting	(1) Check the set pressure value. (2) Check the settings of the comparator output, hysteresis and output type. (In hysteresis mode or window comparator mode, and normal output/reversed output)	(1) Adjust the set pressure value. (2) Set the operation mode, hysteresis and output type again.
		Product failure		Replace the product.
2	The pressure sensor output stays ON. The operation light is normal.	Incorrect wiring	Check the output wiring. Check if the load is directly connected to DC(+) or DC(-).	Check and correct the wiring.
		Product failure		Replace the product.
3	The pressure sensor output stays OFF. The operation light is normal.	Incorrect wiring	Check the output wiring. Check if the load is directly connected to DC(+) or DC(-).	Check and correct the wiring.
		Incorrect SW output specification setting	Check the SW output specification setting. Check if the SW output is PNP while NPN is intended to be set, and vice versa.	Set the SW output specification again.
		Lead wire broken	Check if there is bending stress applied to any part of the lead wire. (bending radius, tensile force to the lead wire)	Correct the wiring. (Reduce the tensile force or increase the bending radius.)
		Product failure		Replace the product.
4	The pressure sensor output generates chattering.	Incorrect wiring	Check the wiring. Check if the brown and blue wires are connected to DC(+) and DC(-) respectively, and if the output line is secure (contact failure).	Correct the connection on the power cord and the plug.
		Incorrect pressure setting	(1) Check the set pressure value. (2) Check if the hysteresis range is small. (3) Check the delay time setting. Check if the delay time is too short.	(1) Adjust the set pressure value. (2) Make the hysteresis wider. (3) Set the delay time again.
		Product failure		Replace the product.
5	The pressure sensor output response is slow.	Incorrect pressure setting	Check the set pressure value. Check if the detected pressure and the set pressure values are the same or are too close.	Adjust the set pressure value .Ensure the set pressure value is not too close to the detected pressure value.

Problem No.	Problem	Problem possible causes	Investigation method	Countermeasures
6	•Over current error (Er1, Er61) is displayed.	Excess current was applied to the output (Er1)	(1) Check if the output current is 80 mA or more. (2) Check if the connected load complies with the specification. Check if the load is short circuited. (3) Check if the relay without surge protection is connected.	(1)(2) Connect the appropriate load. (3) Use a relay with a surge voltage suppressor or take measures to prevent surge. (4) Separate the wiring from the high-voltage and/or power line. (5) Remove the wiring short circuit .
		Excess current was applied to the pressure sensor (Er61)	(4) Check if the wiring is in the same route as (or bundled together with) a high-voltage or power line. (5) Check if the wiring has a short circuit.	
	•Device connection error (Er62) is displayed.	A sensor other than the pressure sensor is connected (Er62)	(1) Check that the correct pressure sensor is connected. (2) Check the sensor connections and wiring.	(1) Connect the correct pressure sensor. (2) Connect using the correct wiring method.
		Applied pressure is higher than the upper limit (HHH)	(1) Check if the pressure exceeds the upper limit of the set pressure range. (2) Check if foreign matter has entered the piping.	(1) Reset applied pressure to a level within the set pressure range. (2) Take measures to prevent foreign matter from entering the piping.
	•"LLL" is displayed. •Residual pressure error (Er3) is displayed.	Applied pressure is lower than the lower limit (LLL)	(1) Check if the pressure exceeds the lower limit of the set pressure range. (2) Check if foreign matter has entered the piping.	(1) Reset applied pressure to a level within the set pressure range. (2) Take measures to prevent foreign matter from entering the piping.
		Pressure is not atmospheric pressure when zero-clear is performed (Er3)	Check if the pressure exceeded the atmospheric pressure within $\pm 7\%$ F.S. ($\pm 3.5\%$ F.S. for compound pressure).	Release the applied pressure to atmospheric pressure, and retry the zero clear operation.
	Product failure			Replace the product.
7	The display is unstable.	Incorrect power supply	Check if the power supply voltage is in the range 4.75 to 5.25 VDC.	Supply power in the range 4.75 to 5.25 VDC.
		Incorrect wiring	Check the power supply wiring. Check if the brown and blue wires are connected to DC(+) and DC(-) respectively, and if the wiring is secure.	Check and correct the wiring.
		Factory line pressure is not stable	Check if the factory line pressure is changing.	If the fluctuation is not acceptable, the number of digits (display sensitivity) can be reduced by changing the display resolution. Digital filter setting may improve the condition.

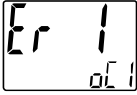
Problem No.	Problem	Problem possible causes	Investigation method	Countermeasures
8	Applied voltage does not match with the displayed pressure value.	Incorrect pressure range setting	Check the pressure range setting. Check if the connected pressure sensor and the set pressure range are correct.	Select the correct pressure range.
9	<ul style="list-style-type: none"> •The display turns OFF. •Part of the display is missing. 	Incorrect power supply	Check if the power supply voltage is in the range 4.75 to 5.25 VDC.	Supply power in the range 4.75 to 5.25 VDC.
		Incorrect wiring	Check the power supply wiring. Check if the brown and blue wires are connected to DC(+) and DC(-) respectively, and if the wiring is secure.	Check and correct the wiring.
		Product failure		Replace the product.
10	Display flashes.	Incorrect wiring	<ol style="list-style-type: none"> (1) Check the power supply wiring for this product. Check that the wiring has not come loose. (2) Check the wiring of the pressure sensor. Check if the wiring is secure. (3) Check if there is bending stress applied to any part of the lead wire. (4) Check that the power supply voltage is 4.75 to 5.25 VDC. 	<ol style="list-style-type: none"> (1) (2) Check and correct the wiring. (3) Correct the wiring (bend radius and stress). (4) Supply a power supply voltage of 4.75 to 5.25 VDC for this product.
11	Buttons do not operate.	Product failure		Replace the product.
12	The operation is unstable. (chattering)	Effect of line pressure fluctuation because hysteresis is too narrow or delay time of the switch is too short	<ol style="list-style-type: none"> (1) Check the set pressure values (hysteresis) (2) Check the delay time. 	<ol style="list-style-type: none"> (1) Adjust the set pressure value. (2) Change the response time setting.
		Incorrect wiring/broken lead wire	<ol style="list-style-type: none"> (1) Check the power supply wiring. (2) Check if there is bending stress applied to any part of the lead wire. (bending radius, tensile force to the lead wire) 	<ol style="list-style-type: none"> (1) Check and correct the wiring. (2) Correct the wiring. (Reduce the tensile force or increase the bending radius.)
		Product failure		Replace the product.

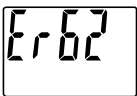
○Error indication function

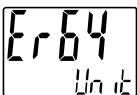
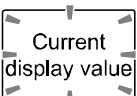
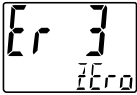
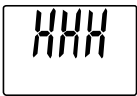
This function is to display the error location and content when a problem or error has occurred.

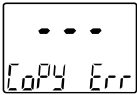
Error	Error displayed	Description	Countermeasures
Over current error (output)		The switch output load current is 80 mA or more.	Turn the power off and remove the cause of the over current. Then supply the power again.
Over current error (power supply)		There is an over current in the pressure sensor.	Check the connection and wiring of the pressure sensor.
Device connection error		The connection between this product and the pressure sensor has failed, or a sensor other than the correct pressure sensor is connected.	Check that the correct pressure sensor is connected. Check the sensor connections and wiring.
Device system error		There is a system error in the process data of the pressure sensor.	Clear the system errors using the process data of the pressure sensor.
Non-SI units error		The units of the connected pressure sensor is other than kPa or MPa.	Use a pressure sensor with units of kPa or MPa.
Mobile battery voltage error		The voltage of the mobile battery is less than 4.5 VDC or more than 5.5 VDC.	Use a mobile battery with a power supply voltage of 4.75 to 5.25 V DC.
Residual pressure error		During zero clear operation, pressure greater than $\pm 7\%$ F.S. ($\pm 3.5\%$ F.S. for compound pressure) is present. Note that the mode is returned to measurement mode automatically 1 second later. The zero clear range varies by $\pm 1\%$ F.S. due to variation between individual products.	Release the applied pressure to atmospheric pressure, and retry the zero clear operation.
Pressurizing error		Pressure exceeding the upper limit of the set pressure range is applied.	Reset applied pressure to a level within the set pressure range. Check the pressure sensor connection and wiring.
		Pressure exceeding the lower limit of the set pressure range is applied. A sensor is not connected or is wired incorrectly.	
Copy error		Failure to operate copy function.	Check the wiring and sensor model, etc., and connect the pressure sensor again.

If the error cannot be reset after the above measures are taken, or errors other than above are displayed, please contact SMC.

Specifications

Product No.		PSE-ST series						
Applicable pressure sensor		PSE541-L	PSE543-L PSE573-L2	PSE574-L2	PSE540-L PSE570-L2	PSE575-L2	PSE576-L2	PSE577-L2
Pressure	Rated pressure range	0 to -101 kPa	-100 to 100 kPa	0 to 500 kPa	0 to 1 MPa	0 to 2 MPa	0 to 5 MPa	0 to 10 MPa
	Display/set pressure range	10 to -105 kPa	-105 to 105 kPa	-50 to 525 kPa	-0.105 to 1.05 MPa	-0.105 to 2.1 MPa	-0.105 to 5.25 MPa	-0.105 to 10.5 MPa
Power supply	Power supply voltage	5 VDC						
	Current consumption	2 A maximum						
	Protection	Over voltage protection						
	Supply connector	USB Type-C						
Sensor input	Number of inputs	1						
	Connection method	Connector						
	Protection	Polarity protection, Over voltage protection						
Display	Display type	LCD						
	Number of displays	3-screen display (Main display, sub display x 2)						
	Display colour	1) Main display: Red/Green 2) Sub display: Orange						
	Number of digits	Main display: 4 digit (7-segments) Sub display: 4 digit (Upper 1 digit 11-segments, 7-segments for other)						
Environment	Enclosure	IP40						
	Withstand voltage	1000 VAC for 1 minute between terminals and housing						
	Insulation resistance	50 MΩ or more between terminals and housing (with 500 VDC megger)						
	Ambient temperature range	Operation: 0 to 45 °C, Storage: -10 to 60 °C (No condensation or freezing)						
	Operating humidity range	Operation, Storage: 35 to 85% RH (No condensation)						
Standard		CE/UKCA/WEEE						
Weight	Body	50 g (without connector)						

*1: Use this product by connecting it to a mobile battery with a 5 VDC, 2 A minimum output.

Do not connect to any power source other than a mobile battery.

If the product does not operate, there is a risk that the power supply may be faulty.

Check the specifications of the mobile battery.

If the mobile battery is used at a temperature higher than the specifications, it may cause a malfunction, fire or burns.

Follow the instructions and precautions for use for the mobile battery.

*2: If this product is connected to a mobile battery that has a function that automatically turns off the power supply according to the current consumption of the mobile battery, this product may not operate correctly.

It is recommended to use a mobile battery that can be switched on and off.

*3: Any products with tiny scratches, smears, or variations in the display colour or brightness, which does not affect the performance of the product, are verified as conforming products.

■Dimensions

○Body

•PSE-ST

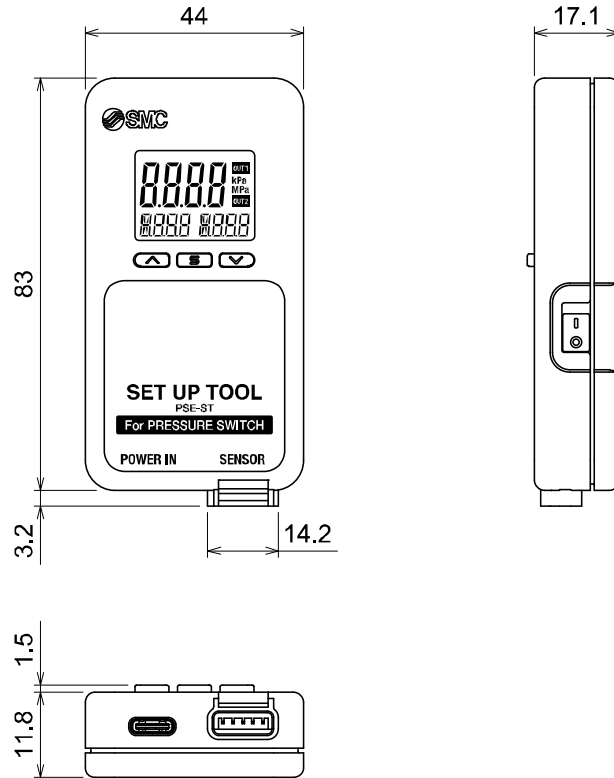

○Connector conversion parts (Part No: D-LH03B)

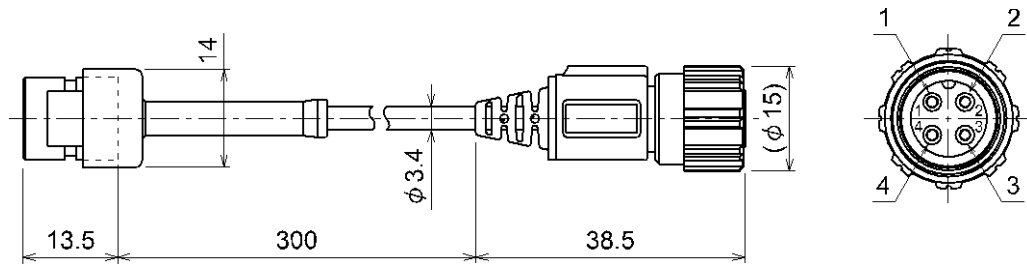

Conductor area		0.15 mm ² (AWG26)
Insulator	Outside diameter	1.0 mm
	Colour	Brown, Blue, Black (3 core)
Sheath	Outside diameter	$\phi 3.4$

○Connector conversion parts (Part No: D-LH03C)

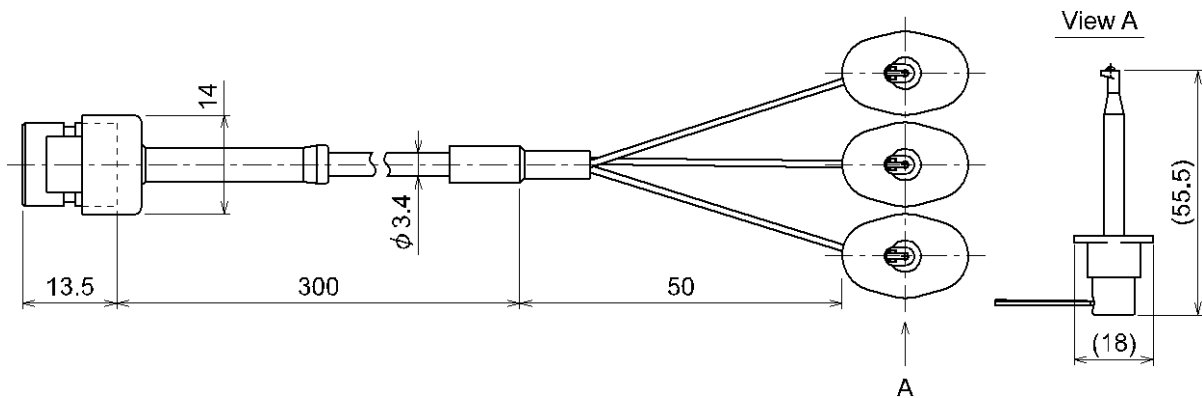

Conductor area		0.15 mm ² (AWG26)
Insulator	Outside diameter	1.0 mm
	Colour	Brown, Blue, Black (3 core)
Sheath	Outside diameter	$\phi 3.4$

Revision history

SMC Corporation

Tel: + 81 3 5207 8249 Fax: +81 3 5298 5362
URL <https://www.smcworld.com>

Note: Specifications are subject to change without prior notice and any obligation on the part of the manufacturer.
© SMC Corporation All Rights Reserved

