



# Operation Manual

PRODUCT NAME

Digital Flow Switch  
(Remote type sensor unit)

MODEL / Series / Product Number

*PFM5##*

**SMC Corporation**

## Table of Contents

Safety Instructions	3
Model Indication and How to Order	11
Summary of Product parts	14
Mounting and Installation	15
Installation	15
Piping	17
Wiring	18
Troubleshooting	20
Error indication	21
Specification	22
Specifications	22
Characteristics data	24
Dimensions	26



# Safety Instructions

These safety instructions are intended to prevent hazardous situations and/or equipment damage. These instructions indicate the level of potential hazard with the labels of “**Caution**,” “**Warning**” or “**Danger**.” They are all important notes for safety and must be followed in addition to International Standards (ISO/IEC)<sup>\*)</sup>, and other safety regulations.

\*1) ISO 4414: Pneumatic fluid power - General rules and safety requirements for systems and their components  
ISO 4413: Hydraulic fluid power - General rules and safety requirements for systems and their components  
IEC 60204-1: Safety of machinery - Electrical equipment of machines - Part 1: General requirements  
ISO 10218-1: Robots and robotic devices - Safety requirements for industrial robots - Part 1: Robots  
etc.



## **Danger**

**Danger** indicates a hazard with a high level of risk which, if not avoided, will result in death or serious injury.



## **Warning**

**Warning** indicates a hazard with a medium level of risk which, if not avoided, could result in death or serious injury.



## **Caution**

**Caution** indicates a hazard with a low level of risk which, if not avoided, could result in minor or moderate injury.



## **Warning**

### **1. The compatibility of the product is the responsibility of the person who designs the equipment or decides its specifications.**

Since the product specified here is used under various operating conditions, its compatibility with specific equipment must be decided by the person who designs the equipment or decides its specifications based on necessary analysis and test results. The expected performance and safety assurance of the equipment will be the responsibility of the person who has determined its compatibility with the product. This person should also continuously review all specifications of the product referring to its latest catalog information, with a view to giving due consideration to any possibility of equipment failure when configuring the equipment.

### **2. Only personnel with appropriate training should operate machinery and equipment.**

The product specified here may become unsafe if handled incorrectly. The assembly, operation and maintenance of machines or equipment including our products must be performed by an operator who is appropriately trained and experienced.

### **3. Do not service or attempt to remove product and machinery/equipment until safety is confirmed.**

1. The inspection and maintenance of machinery/equipment should only be performed after measures to prevent falling or runaway of the driven objects have been confirmed.
2. When the product is to be removed, confirm that the safety measures as mentioned above are implemented and the power from any appropriate source is cut, and read and understand the specific product precautions of all relevant products carefully.
3. Before machinery/equipment is restarted, take measures to prevent unexpected operation and malfunction.

### **4. Our products cannot be used beyond their specifications. Our products are not developed, designed, and manufactured to be used under the following conditions or environments. Use under such conditions or environments is not covered.**

1. Conditions and environments outside of the given specifications, or use outdoors or in a place exposed to direct sunlight.
2. Use for nuclear power, railways, aviation, space equipment, ships, vehicles, military application, equipment affecting human life, body, and property, fuel equipment, entertainment equipment, emergency shut-off circuits, press clutches, brake circuits, safety equipment, etc., and use for applications that do not conform to standard specifications such as catalogs and operation manuals.
3. Use for interlock circuits, except for use with double interlock such as installing a mechanical protection function in case of failure. Please periodically inspect the product to confirm that the product is operating properly.



# Safety Instructions

## Caution

**We develop, design, and manufacture our products to be used for automatic control equipment, and provide them for peaceful use in manufacturing industries.**

**Use in non-manufacturing industries is not covered.**

Products we manufacture and sell cannot be used for the purpose of transactions or certification specified in the Measurement Act.

The new Measurement Act prohibits use of any unit other than SI units in Japan.

## Limited warranty and Disclaimer/Compliance Requirements

The product used is subject to the following “Limited warranty and Disclaimer” and “Compliance Requirements”. Read and accept them before using the product.

### Limited warranty and Disclaimer

1. The warranty period of the product is 1 year in service or 1.5 years after the product is delivered, whichever is first.\*2)  
Also, the product may have specified durability, running distance or replacement parts. Please consult your nearest sales branch.
2. For any failure or damage reported within the warranty period which is clearly our responsibility, a replacement product or necessary parts will be provided.  
This limited warranty applies only to our product independently, and not to any other damage incurred due to the failure of the product.
3. Prior to using SMC products, please read and understand the warranty terms and disclaimers noted in the specified catalog for the particular products.

**\*2) Vacuum pads are excluded from this 1 year warranty.**

A vacuum pad is a consumable part, so it is warranted for a year after it is delivered.

Also, even within the warranty period, the wear of a product due to the use of the vacuum pad or failure due to the deterioration of rubber material are not covered by the limited warranty

### Compliance Requirements

1. The use of SMC products with production equipment for the manufacture of weapons of mass destruction (WMD) or any other weapon is strictly prohibited.
2. The exports of SMC products or technology from one country to another are governed by the relevant security laws and regulations of the countries involved in the transaction. Prior to the shipment of a SMC product to another country, assure that all local rules governing that export are known and followed.

## Operator

- ◆ This operation manual is intended for those who have knowledge of machinery using pneumatic equipment, and have sufficient knowledge of assembly, operation and maintenance of such equipment. Only those persons are allowed to perform assembly, operation and maintenance.
- ◆ Read and understand this operation manual carefully before assembling, operating or providing maintenance to the product.

### ■ Safety Instructions

#### **Warning**

- Do not disassemble, modify (including changing the printed circuit board) or repair.  
An injury or failure can result.
- Do not operate the product outside of the specifications.  
Do not use for flammable or harmful fluids.  
Fire, malfunction, or damage to the product can result.  
Verify the specifications before use.
- Do not operate in an atmosphere containing flammable or explosive gases.  
Fire or an explosion can result.  
This product is not designed to be explosion proof.
- Do not use the product for flammable fluid.  
A fire or explosion can result.  
Only dry air, N<sub>2</sub>, CO<sub>2</sub> and Ar are applicable.
- Do not use the product in a place where static electricity is a problem.  
Otherwise it can cause failure or malfunction of the system.
- If using the product in an interlocking circuit:
  - Provide a double interlocking system, for example a mechanical system.
  - Check the product regularly for proper operationOtherwise malfunction can result, causing an accident.
- The following instructions must be followed during maintenance :
  - Turn off the power supply
  - Stop the air supply, exhaust the residual pressure and verify that the air is released before performing maintenance work.Otherwise an injury can result.

## Caution

- Do not touch the terminals and connectors while the power is on.  
Otherwise electric shock, malfunction or damage to the product can result.
- After maintenance is complete, perform appropriate functional inspections and leak tests.  
Stop operation if the equipment does not function properly or there is a leakage of fluid.  
When leakage occurs from parts other than the piping, the product might be faulty.  
Disconnect the power supply and stop the fluid supply.  
Do not apply fluid under leaking conditions.  
Safety cannot be assured in the case of unexpected malfunction.

### ■ NOTE

- Follow the instructions given below when designing, selecting and handling the product.
  - The instructions on design and selection (installation, wiring, environment, adjustment, operation, maintenance, etc.) described below must also be followed.
    - \*Product specifications
      - The direct current power supply used should be UL approved as follows.  
Circuit (Class 2) of maximum 30 Vrms (42.4 V peak) or less, with UL1310 Class 2 power supply unit or UL1585 Class 2 transformer.
      - The product is a UL approved product only if it has a  mark on the body.
      - Use the specified voltage.  
Otherwise failure or malfunction can result.  
Insufficient supply voltage may not drive a load due to a voltage drop inside the product.  
Verify the operating voltage of the load before use.
      - Do not exceed the specified maximum allowable load.  
Otherwise it can cause damage or shorten the lifetime of the product.
      - Applicable operating fluid depends on the product.  
Check the details of the specifications before using.
      - Before designing piping confirm the pressure loss at the sensor from the pressure loss graph.  
Confirm pressure loss of the sensor from the characteristics data.
      - For the details of compressed air quality, refer to ISO 8573-1, 1.1.2 to 1.6.2.
      - Use the specified measurement flow rate and operating pressure.  
Otherwise it can cause damage to the product or inability to measure correctly.
      - Reserve a space for maintenance.  
Allow sufficient space for maintenance when designing the system.

●Product handling

\*Installation

- Tighten to the specified tightening torque.

If the tightening torque is exceeded the mounting screws and brackets may be damaged.

If the tightening torque is insufficient, the product may be displaced and the mounting screws may come loose (Refer to page 15 "Mounting and Installation".)

- Do not apply excessive stress to the product when it is mounted with a panel mount.

Otherwise damage to the product and disconnection from the panel mount can result.

- Ensure that the FG terminal is connected to ground when using a commercially available switch-mode power supply.

- Do not drop, hit or apply excessive shock to the product.

Otherwise damage to the internal parts can result, causing malfunction.

- Do not pull the lead wire forcefully, or lift the product by the lead wire. (Tensile force 49 N or less)

Hold the product body when handling, to prevent damage, failure or malfunction

- For piping of the product, hold the piping with a spanner on the metal part of the product (Piping attachment).

Holding other parts with a spanner leads to may damage the product.

- Any dust left in the piping should be flushed out by air blow before connecting the piping to the product.

Otherwise damage or malfunction can result.

- Refer to the flow direction of the fluid indicated on the product label for installation and piping.

Remaining air can cause inability to measure accurately.

- Do not mount the body with the bottom facing upwards.

Remaining air can cause inability to measure accurately.

- Do not insert metal wires or other foreign matter into the piping port.

This can damage the sensor causing failure or malfunction.

- Never mount a product in a location that will be used as a foothold.

The product may be damaged if excessive force is applied by stepping or climbing onto it.

- If there is a risk of foreign matter entering the fluid, install and pipe a filter or the mist separator at the inlet to avoid failure and malfunction.

Otherwise damage or malfunction can result.

And it can cause inability to measure accurately.

Refer to the figure below for the recommended pneumatic circuit.

Recommended pneumatic circuit example

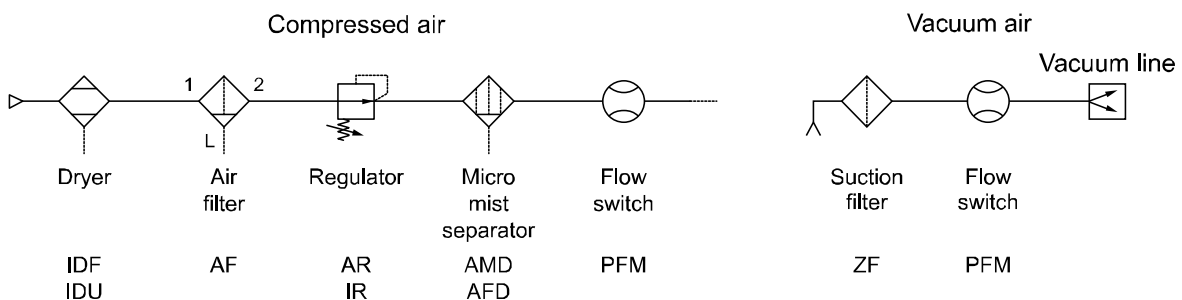

#### \*Wiring

- Do not pull the lead wires.

In particular, never lift a product equipped with fitting and piping by holding the lead wires.

Otherwise damage to the internal parts can result, causing malfunction or disconnection of the connector.

- Avoid repeatedly bending or stretching the lead wire, or placing heavy loads on it

Repeated bending stress or tensile stress can cause damage to the sheath, or breakage of the wires.

If the lead wire can move, fix it near the body of the product.

The recommended bend radius of the lead wire is 6 times the outside diameter of the sheath, or 33 times the outside diameter of the wire insulation material, whichever is larger.

Replace any damaged lead wire with a new one.

- Wire correctly.

Incorrect wiring can damage the product.

- Do not perform wiring while the power is on.

Otherwise damage to the internal parts can result, causing malfunction.

- Do not route wires and cables together with power or high voltage cables.

Otherwise the product can malfunction due to interference or noise and surge voltage from power and high voltage cables.

- Confirm proper insulation of wiring.

Poor insulation (interference from another circuit, poor insulation between terminals, etc.) can lead to excess voltage or current being applied to the product, causing damage.

- Keep wiring as short as possible to prevent interference from electromagnetic noise and surge voltage.

Do not use a cable longer than 30 m.

Wire the DC (-) line (blue) as close as possible to the power supply.

- When analogue output is used, install a noise filter (line noise filter, ferrite element, etc.) between the switch-mode power supply and this product.



#### \*Environment

- Do not use the product in area that is exposed to corrosive gases, chemicals, sea water, water or steam.  
Otherwise failure or malfunction can result.
- Do not use in a place where the product could be splashed by oil or chemicals.  
If the product is to be used in an environment containing oils or chemicals such as coolant or cleaning solvent, even for a short time, it may be adversely affected (damage, malfunction, or hardening of the lead wires)
- Do not use in an area where electrical surges are generated.  
If there is equipment generates large electrical surges (solenoid type lifter, high frequency induction furnace, motor, etc.) close to the product, damage or failure of the internal circuit may occur. Take measures against the surge sources, and prevent the wires from coming into close contact.
- Do not use a load which generates a surge voltage.  
When a surge-generating load such as a relay or solenoid is driven directly, use a load with a built-in surge suppressor.
- The product is CE/UKCA marked, but not immune to lightning strikes. Take measures against lightning strikes in the system.
- Do not use the product in areas that are exposed to vibration or impact.  
Otherwise failure or malfunction can result.
- Do not use the product in the presence of a magnetic field.  
This may lead to the malfunction of the product.
- Prevent foreign matter such as wire debris from entering the product.  
Otherwise failure or malfunction can result.
- Do not use the product in areas subject to large temperature cycle.  
Heating/cooling cycles other than ordinary changes in temperature can adversely affect the internal structure of the product
- Do not expose the product to direct sunlight.  
If using in a location directly exposed to sunlight, use a suitable protective cover.  
Otherwise failure or malfunction can result.
- Keep within the operating fluid temperature and operating temperatures range.  
The operating fluid temperature and operating temperature range is 0 to 50 °C.  
Operation below the minimum temperature limit may cause damage or operation failure due to frozen moisture in the fluid or air.  
An air dryer is recommended for elimination of drainage and water.  
Avoid sudden temperature changes even within the specified temperature range.
- Do not operate close to a heat source, or in a location exposed to radiant heat.  
Otherwise malfunction can result.
- The temperature between products rises when sticking is installed, and there is a possibility to influence the performance of the product.

**\*Adjustment and Operation**

- Do not short-circuit the load.

When the product load is short circuit, generated excess current lead to cause the damage of the product.

- Supply the power when there is no flow.

**\*Maintenance**

- Perform regular maintenance and inspections.

There is a risk of unexpected malfunction of components due to the malfunction of equipment and machinery.

- Turn off the power supply, stop the supplied air, exhaust the residual pressure and verify the release of air before performing maintenance.

There is a risk of unexpected malfunction.

- Perform drainage regularly.

If condensate enters the outside, it can cause operating failure of pneumatic equipment.

- Do not use solvents such as benzene, thinner etc. to clean the product.

They could damage the surface of the body and erase the markings on the body.

Use a soft cloth to remove stains.

For heavy stains, use a cloth lightly dampened with diluted neutral detergent, then wipe up any residue with a dry cloth.

**\*Other**

- If it has a restrictor, the flow adjustment valve may rotate due to vibration and change the flow rate.

- Accuracy may vary by 2 to 3% if the customer removes or replaces the piping port themselves.

# Model Indication and How to Order

PFM 5 □ □ - □ □ - □ □ - □ □ - □ □

Remote type sensor

Rated flow range

Symbol	Content
10	0.2 to 10 (5) L/min
25	0.5 to 25 (12.5) L/min
50	1 to 50 (25) L/min
11	2 to 100 (50) L/min

\*: Value in ( ) is the flow rate when CO2 is used.

Flow adjustment valve

Symbol	Content
Nil	without flow adjustment valve
S	with flow adjustment valve

Option2  
(Refer to page 12.)

Option1  
(Refer to page 12.)

Calibration certificate

Symbol	Content
Nil	without calibration certificate
A	with calibration certificate *2

\*2: Certificate in both Japanese and English.

Operation manual

Symbol	Content
Nil	with operation manual (Japanese and English)
N	without operation manual

Output specification

Symbol	Content	Applicable model
1	Analogue (1 to 5 V)	PFM30# series
2	Analogue (4 to 20 mA)	PFM31# series

Piping direction

Symbol	Content
Nil	Straight
L	Bottom entry

Thread type (Port size)

Symbol	Content	Flow range			
		10	25	50	11
01	Rc1/8	●	●	●	-
02	Rc1/4	-	-	-	●
N01	NPT1/8	●	●	●	-
N02	NPT1/4	-	-	-	●
F01	G1/8	●	●	●	-
F02	G1/4	-	-	-	●
C4	φ 4(5/32") One-touch fitting	●	-	-	-
C6	φ 6 One-touch fitting	●	●	●	●
C8	φ 8(5/16") One-touch fitting	-	●	●	●
N7	φ 1/4 One-touch fitting	-	●	●	●

### Option 1

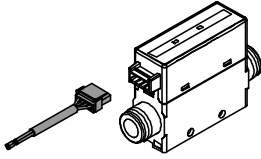
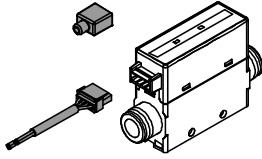
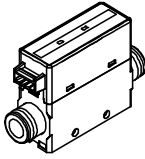
Nil	W	Z
<p>with lead wire and connector (2 m)</p> 	<p>with lead wire and connector (2 m)+ Connector cover (silicone rubber)</p> 	<p>without lead wire</p> 

### Option 2

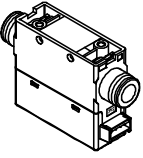
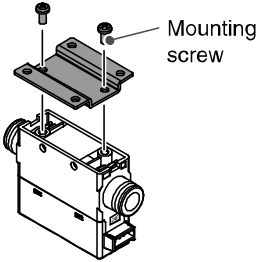
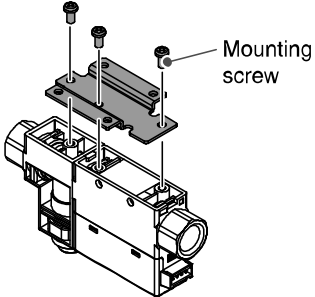
Nil	R	S
<p>without bracket</p> 	<p>with bracket (without flow adjustment valve)</p>  <p>Mounting screw</p>	<p>with bracket (with flow adjustment valve)</p>  <p>Mounting screw</p> <p>Not applicable to bottom entry type</p>

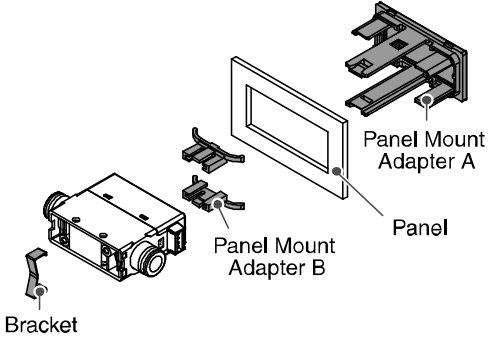
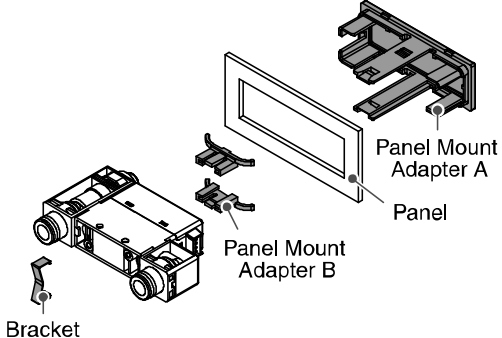
T	V
<p>with panel mount adapter (without flow adjustment valve)</p>  <p>Bracket</p> <p>Panel Mount Adapter B</p> <p>Panel Mount Adapter A</p> <p>Panel</p>	<p>with panel mount adapter (with flow adjustment valve)</p>  <p>Bracket</p> <p>Panel Mount Adapter B</p> <p>Panel Mount Adapter A</p> <p>Panel</p>

\*: Each accessory is not assembled with the product, but shipped together.

### Accessories/Part number

If an accessory is required separately, order using the following part numbers.

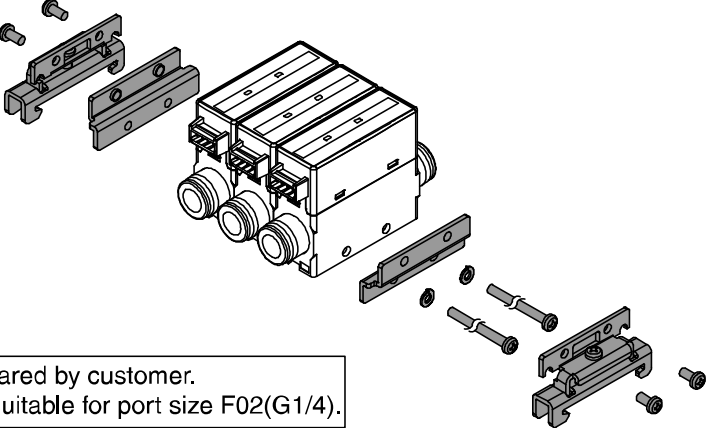
Part number.	Description	Remarks										
ZS-33-D	Lead wire connector	Length: 2 m										
ZS-33-F	Connector cover (silicone rubber) 											
ZS-33-J	Panel mount adapter (without flow adjustment valve)											
ZS-33-JS	Panel mount adapter (with flow adjustment valve)											
ZS-33-M	Bracket (without flow adjustment valve)	Mounting screw 2 pcs.										
ZS-33-MS	Bracket (with flow adjustment valve)	Mounting screw 3 pcs.										
ZS-33-R#	<p>DIN rail mounting parts</p> <p>ZS-33-R <input type="checkbox"/></p> <p>Number of stations</p> <table border="1"> <tbody> <tr> <td>1</td> <td>1 station</td> </tr> <tr> <td>2</td> <td>2 stations</td> </tr> <tr> <td>3</td> <td>3 stations</td> </tr> <tr> <td>4</td> <td>4 stations</td> </tr> <tr> <td>5</td> <td>5 stations</td> </tr> </tbody> </table>  <div style="border: 1px solid black; padding: 5px; margin-top: 10px;"> <ul style="list-style-type: none"> <li>• DIN rail is prepared by customer.</li> <li>• DIN rail is not suitable for port size F02(G1/4).</li> </ul> </div>	1	1 station	2	2 stations	3	3 stations	4	4 stations	5	5 stations	
1	1 station											
2	2 stations											
3	3 stations											
4	4 stations											
5	5 stations											

## Summary of Product parts

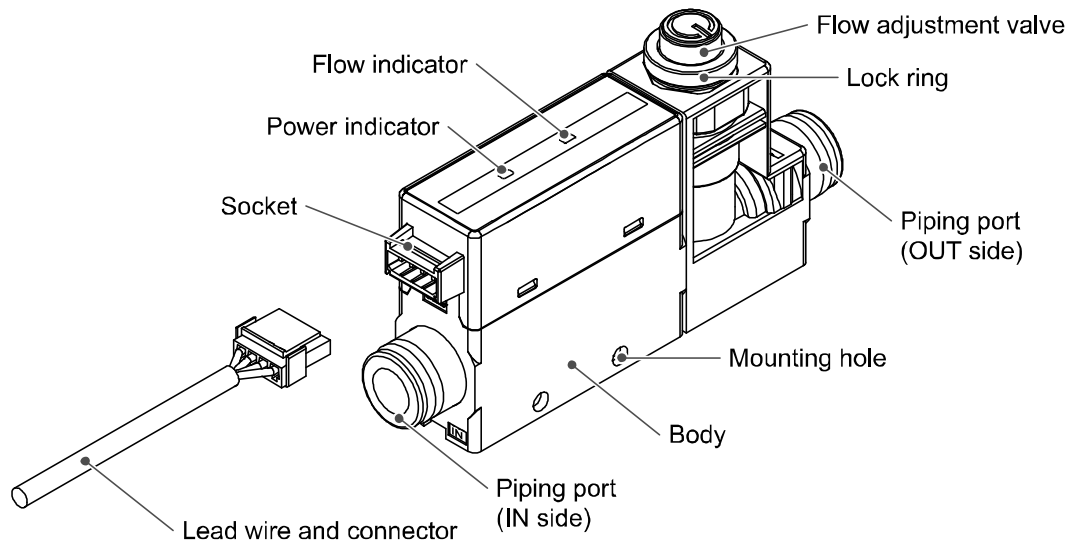

Item	Description
Flow indicator LED	Indicates the flow status. LED is flashing (Green) when flow is detected. As the flow rate increases, the flashing rate increases. LED is ON (Red) when the max. rated flow has been exceeded.
Power indicator LED	Indicates the power supply status. LED is ON (Green) when power is ON. LED is ON (Red) when a system error occurred.
Socket	Socket for electrical connections.
Piping port	Connected to the fluid inlet at IN side and to the fluid outlet at OUT side.
Flow adjustment valve *	Orifice mechanism to adjust the flow.
Lock ring *	Used to lock the flow adjustment valve.
Mounting hole	Used to mount the product on a DIN rail or directly to a panel.
Body	The body of the product.
Lead wire and connector	Cable to supply power and transmit output signals.

\*: The table shows the specifications when a flow adjusting valve is included.

## Mounting and Installation

### ■ Installation

- Refer to the flow direction of the fluid indication on the product label for installation and piping.

#### Panel mounting

- Insert Panel Mount Adapter B (supplied as an accessory) into Section A of Panel Mount Adapter A. Push Panel Mount Adapter B from behind until the display is fixed onto the panel.  
The pin of bracket engages the notched part of panel adapter A section C to fix the display.
- The switch can be mounted on a panel with a thickness of 1 to 3.2 mm.
- Refer to the dimension drawing (page 38) for panel cut-out dimensions.

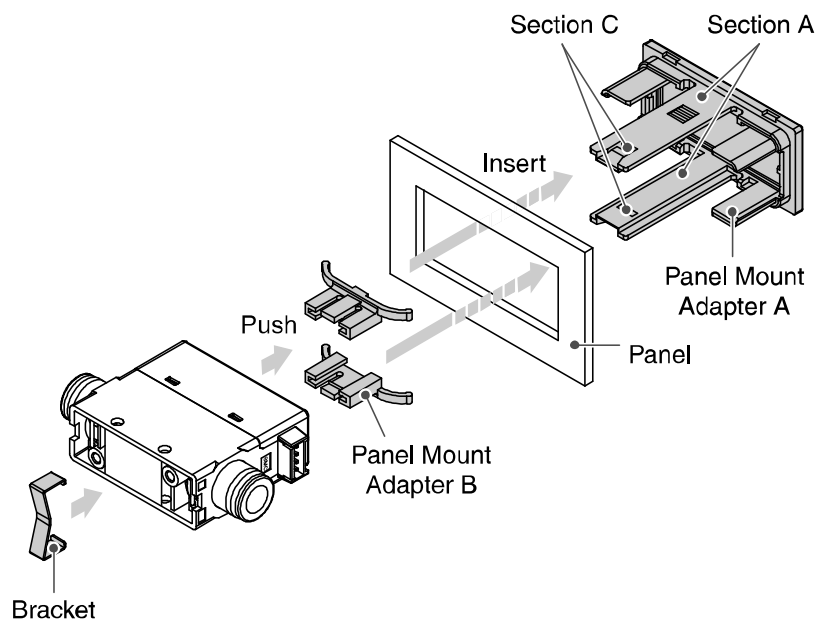

### Bracket mounting

- Mount the bracket using the mounting screws supplied.
- The required tightening torque is  $0.5 \pm 0.05 \text{ N}\cdot\text{m}$ .

Without flow adjustment valve  
(using ZS-33-M)

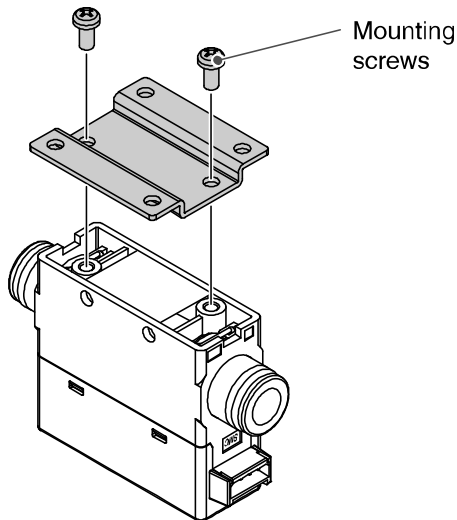

With flow adjustment valve  
(using ZS-33-MS)

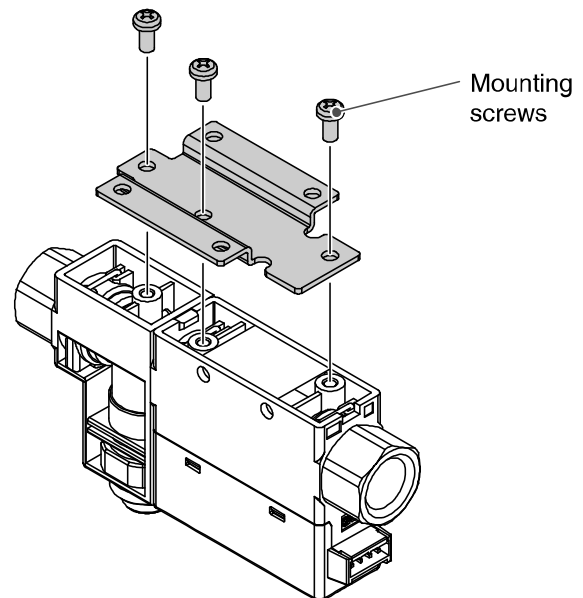

- Install the product (with bracket) using the M3 screws (4 pcs.).
- Bracket thickness is approximately 1.2 mm.
- Refer to the dimension drawing of the bracket (page 38) for mounting hole dimensions.

### DIN rail mounting (using ZS-33-R#)

- Mount the DIN rail mounting parts using DIN rail mounting screws and joint screws supplied.
- The required tightening torque of the DIN rail mounting screws and joint screws is  $0.4 \pm 0.05 \text{ N}\cdot\text{m}$ .

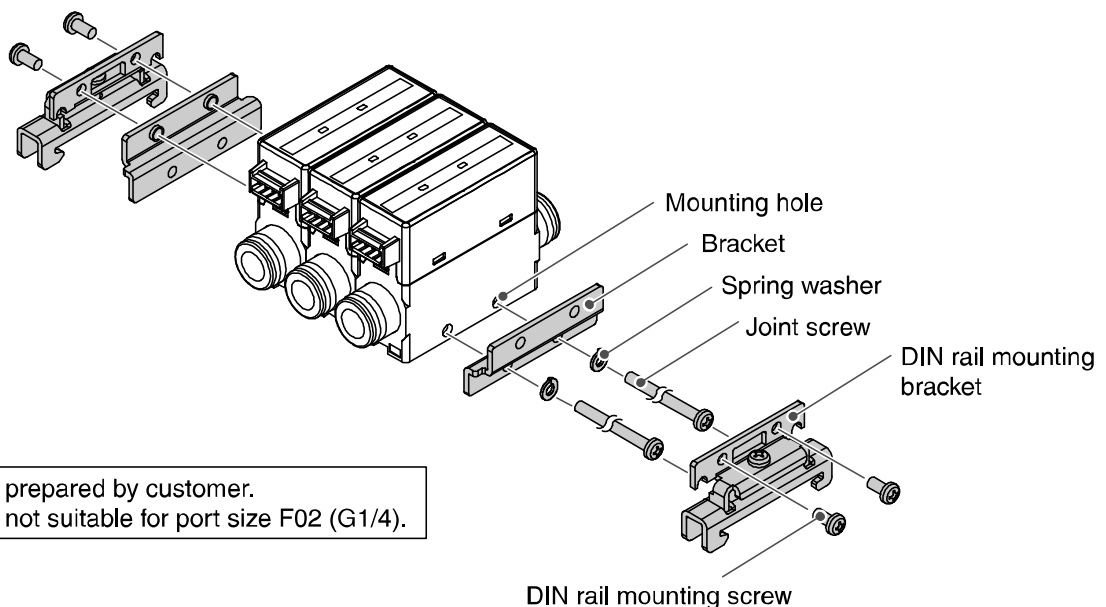

- DIN rail is prepared by customer.
- DIN rail is not suitable for port size F02 (G1/4).



## ■Piping

### For the metal piping attachments

- Ensure that the metal piping attachments are tightened to the required torque (refer to the table below).
- If the tightening torque is exceeded, the product can be broken. If the tightening torque is insufficient, the fittings may become loose.
- When connecting piping to the product, a spanner should be used on the metal piping attachment only. Using a spanner on other parts may damage the product.
- Avoid any sealing tape from entering inside the piping.
- Ensure that there is no leakage from loose piping.

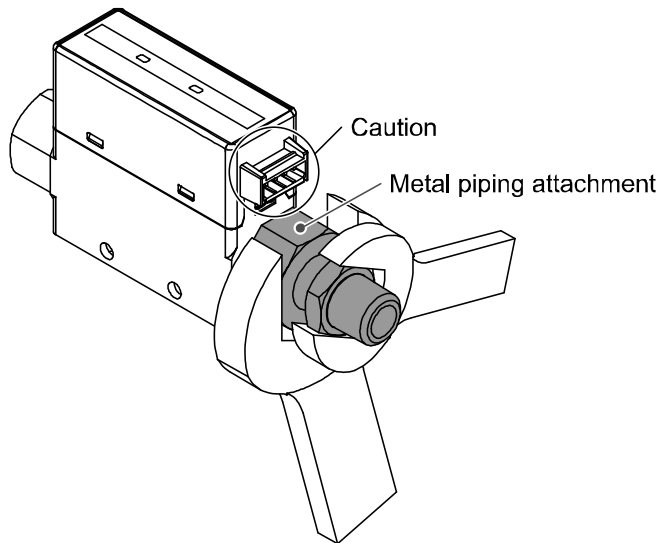

Nominal thread size	Required torque
Rc(NPT)1/8	7 to 9 N•m
Rc(NPT)1/4	12 to 14 N•m

Nominal thread size	Width across flats of attachment
Rc(NPT)1/8 Rc(NPT)1/4 G1/8	17 mm
G1/4	21 mm

### For one-touch fittings

- Insert the tube until it bottoms out, to ensure it cannot be pulled out.
- Insertion with excessive force can cause damage.
- Ensure that there is no leakage after piping.
- Use this product within the specified operating pressure and temperature ranges.
- Proof pressure is 1.0 MPa.

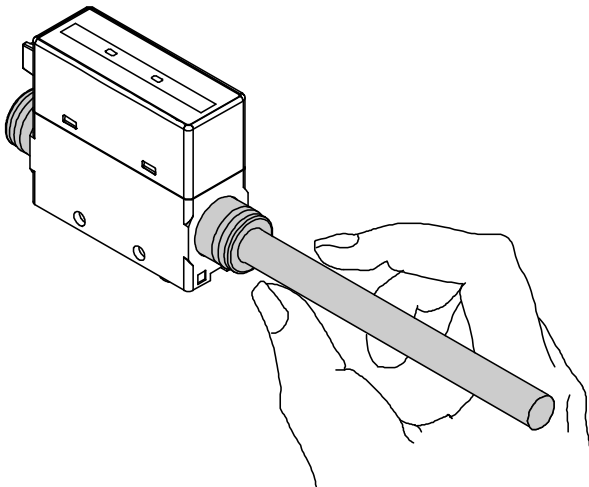

## ■Wiring

### Wiring of connector

- Connections should only be made with the power supply turned off.
- Use separate routes for the product wiring and any power or high voltage wiring. Otherwise, malfunction may result due to noise.
- Ensure that the FG terminal is connected to ground when using a commercially available switch-mode power supply. When a switch-mode power supply is connected to the product, switching noise will be superimposed and the product specification can no longer be met. This can be prevented by inserting a noise filter, such as a line noise filter and ferrite core, between the switch-mode power supply and the product, or by using a series power supply instead of a switch-mode power supply.

### Connecting/Disconnecting

- When mounting the connector, insert it straight into the socket, holding the lever and connector body, and push the connector until the lever hooks into the housing, and locks.
- When removing the connector, press down the lever to release the hook from the housing and pull the connector straight out.

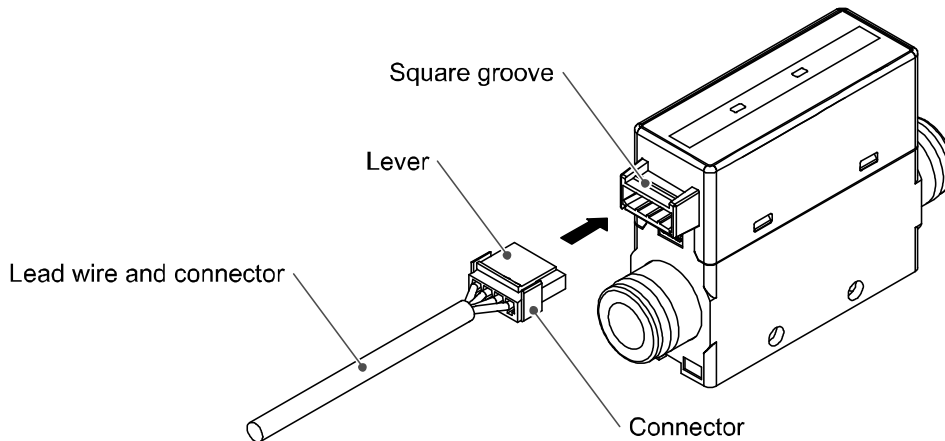

### Connector pin numbers (on the lead wire)

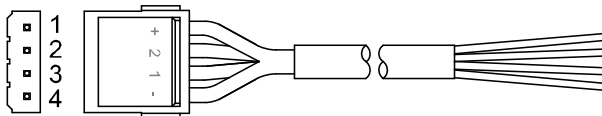

Connector pin numbers	Wire colour	Description
1	Brown	DC(+)
2	White	Select response time (input)
3	Black	Analogue output
4	Blue	DC(-)

## Internal circuit and wiring example

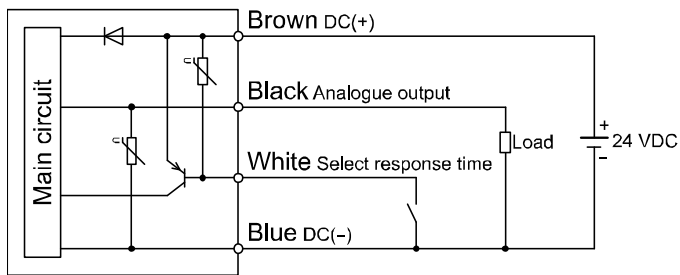

Analogue output: 1 to 5 V

Output impedance: 1 k $\Omega$

Analogue output: 4 to 20 mA

Max. load impedance: 600  $\Omega$  (24 VDC)

Min. load impedance: 50  $\Omega$

Select response time (input): No voltage input (reed switch or solid state switch), 30 ms or more

### Select response time (input)

The response time can be selected to improve the stability of the analogue output, if the output is unstable due to flow rate pulsation.

### How to select the response time

Connect the response time input wire (white) to GND. While connected, the response time will be 1.0 second, or 50 ms when not connected.

## Troubleshooting

### Troubleshooting

If an operation failure occurs with the product, use the chart below to find out the cause of the problem. If none of the countermeasures seem to be applicable, or a replacement product operates normally when installed, the product may be faulty. A product can be damaged by the operating environment (system configuration etc). If the product seems to be faulty, please contact SMC.

#### ●Faults and countermeasures

Fault	Status	Possible cause	Item to check	Countermeasure
Indicator LED failure	Indicator LED does not turn ON	Incorrect wiring	Check that the brown and blue wires are connected to DC (+) and DC (-) respectively.	Correct the wiring.
		Loose connector	Check the connectors.	Correct the connector wiring.
	Flow indicator LED is not stable	Foreign matter has entered the flow passage or adhered to the sensor	(1)Check if any foreign matter has entered the flow passage. (2) Check if there is foreign matter on the mesh.	Install a filter or mist separator on the IN side.
		Piping in the reverse direction	Check that the fluid flow is in the same direction as marked on the product body.	Ensure the product is mounted so that the fluid flow matches the direction marked on the product body.
		Flow is pulsing	Check if there is any supply pressure fluctuation or pressure pulsation due to the characteristics of the source compressor (or pump).	Install an accumulator tank to reduce the pressure fluctuation. Change the pressure source to one that has less pulsation.

Fault	Status	Possible cause	Item to check	Countermeasure
Incorrect output	No output	Incorrect wiring	Check that the brown, blue, black and white wires are connected correctly.	Correct the wiring.
		Connector is disconnected	Check the connectors.	Correct the connector wiring.
	Output is unstable	Foreign matter has entered the flow passage or adhered to the sensor	(1) Check if any foreign matter has entered the flow passage. (2) Check if there is foreign matter on the mesh.	Install a filter or mist separator on the IN side.
		Piping in the reverse direction	Check that the fluid flow is in the same direction as marked on the product body.	Ensure the product is mounted so that the fluid flow matches the direction marked on the product body.
		Flow is pulsing	Check if there is any supply pressure fluctuation or pressure pulsation due to the characteristics of the source compressor (or pump).	Install an accumulator tank to reduce the pressure fluctuation. Change the pressure source to one that has less pulsation.
Air leakage	Check for air leakage due to loose piping or insufficient sealant, etc.	Reconnect the piping with the specified tightening torque and re-apply the sealant tape.		
Incorrect operation of the flow adjustment valve	The flow adjustment valve fails to adjust the flow	The flow adjustment valve is locked	Check the lock ring on the flow adjustment valve.	Loosen the lock ring, and then adjust the flow adjustment valve.
		Insufficient supply pressure	Check the supply pressure and the flow characteristics of the flow adjustment valve.	Increase the supply pressure.

## ■ Error indication

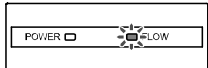
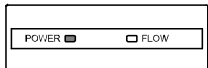
Error Name	Display	Type	Troubleshooting
Flow Error	 <p>Flow indicator is red flashing.</p>	Flow has exceeded the upper limit of the rated flow range.	Reduce the flow.
System Error	 <p>Power indicator is red.</p>	System error. The internal circuit may be damaged.	Turn the power off and turn it on again.

\*: If the error cannot be reset after the above measures are taken, then please contact SMC.

# Specification

## ■ Specifications

Model		PFM510	PFM525	PFM550	PFM511
Applicable fluid		Dry air, N <sub>2</sub> , Ar, CO <sub>2</sub> (air quality class to ISO8573-1 1.1.2 to 1.6.2)			
Rated flow range	Dry air, N <sub>2</sub> , Ar	0.2 to 10 L/min	0.5 to 25 L/min	1 to 50 L/min	2 to 100 L/min
	CO <sub>2</sub>	0.2 to 5 L/min	0.5 to 12.5 L/min	1 to 25 L/min	2 to 50 L/min
Accuracy		±3%F.S. max.			
Repeatability		±1%F.S. max. (fluid: Dry air)			
Temperature characteristics		±2%F.S. max. (15 to 35 °C) ±5%F.S. max. (0 to 15 °C, 35 to 50 °C)			
Pressure characteristics		±5%F.S. max. (0.35 MPa reference)			
Rated pressure range		-70 kPa to 750 kPa			
Proof pressure		1 MPa			
Analogue output	Response time	50 msec. (when "Select response time" wire (white) is connected to GND, response time is 1 sec.)			
	Voltage output	Output voltage: 1 to 5 V Output impedance: 1 kΩ			
	Current output	Output current: 4 to 20 mA Max. load impedance: 600 Ω (24 VDC) Min. load impedance: 50 Ω			
Input Selection response time		No voltage input (Reed switch or solid state switch) 30 ms or more			
Power indicator LED		Green LED is ON : Power is ON Red LED is ON : System Error			
Flow indicator LED		Green LED is flashing : Flow is detected Red LED is ON : Flow Error			
Supply voltage		24 VDC±10%			
Power consumption		35 mA or less			
Environment	Enclosure	IP40			
	Operating fluid temperature	0 to 50 °C (no freezing or condensation)			
	Operating temp. range	Operating: 0 to 50 °C, Stored: -10 to 60 °C (no freezing or condensation)			
	Operating humidity range	Operating, stored 35 to 85%R.H. (no condensation)			
	Withstand voltage	1000 VAC, 1 min. between terminals and case			
	Insulation resistance	50 MΩ min. (at 500 VDC) between terminals and case			
Standards		CE/UKCA marked, UL (CSA)			

### Specifications of piping port

Model		01	02	N01	N02	F01	F02	C4	C6	C8	N7
Thread type (Port size)		Rc 1/8	Rc 1/4	NPT 1/8	NPT 1/4	G 1/8	G 1/4	φ4 (5/32") One- touch fitting	φ6 One- touch fitting	φ8 (5/16") One- touch fitting	φ1/4 One- touch fitting
Weight	Straight without flow adjustment valve	95 g				125 g		55 g			
	Bottom entry without flow adjustment valve	105 g				135 g		65 g			
	Straight with flow adjustment valve	135 g				165 g		95 g			
	Bottom entry with flow adjustment valve	145 g				175 g		105 g			
Material of parts in contact with fluid		LCP, PBT, brass (electroless nickel plating), HNBR (+ fluoro coating), FKM (+ fluoro coating), Si, Au, SUS304									

### Cable specifications

Conductor	Nominal cross section area	AWG26
	Individual wire diameter	approx. 0.50 mm
Insulator	Outside diameter	Approx. 1.00 mm
	Colours	Brown, White, Black, Blue
Sheath	Material	Lead free heat and oil resistance PVC
	Outer diameter	approx. φ3.5

## ■ Characteristics data

### ● Analogue output characteristics

\*: Analogue output at maximum rated flow rate when CO<sub>2</sub> is selected is 4.57 [V] for the voltage output type and 18.28 [mA] for the current output type.

Analogue voltage output (1 to 5 V)

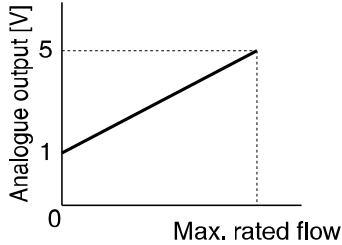

Analogue current output (4 to 20 mA)

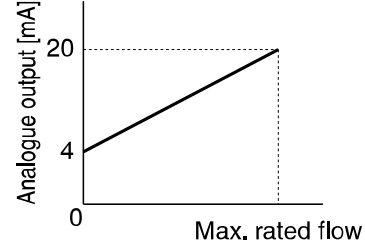

Model	Max. rated flow [L/min]
PFM510-#-1	10 (5)
PFM525-#-1	25 (12.5)
PFM550-#-1	50 (25)
PFM511-#-1	100 (50)

\*( ): Fluid: CO<sub>2</sub>

Model	Max. rated flow [L/min]
PFM510-#-2	10 (5)
PFM525-#-2	25 (12.5)
PFM550-#-2	50 (25)
PFM511-#-2	100 (50)

\*( ): Fluid: CO<sub>2</sub>

### ● Flow adjustment needle revolution - Flow characteristics (reference value)

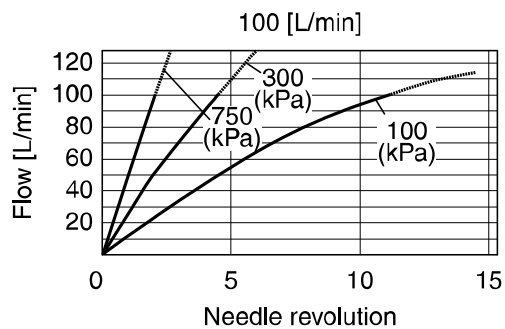
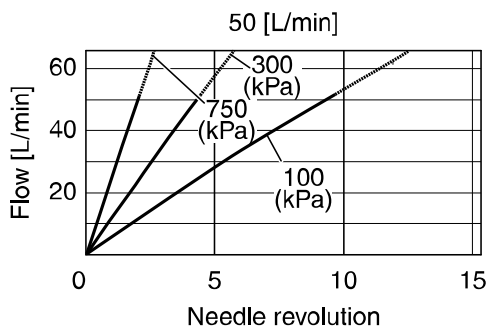
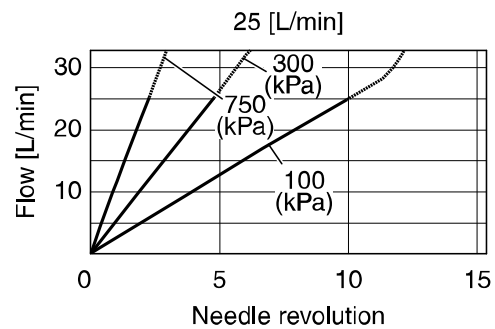
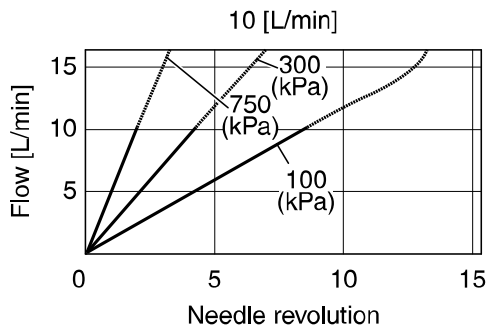



● Pressure loss (at 350 [kPa])

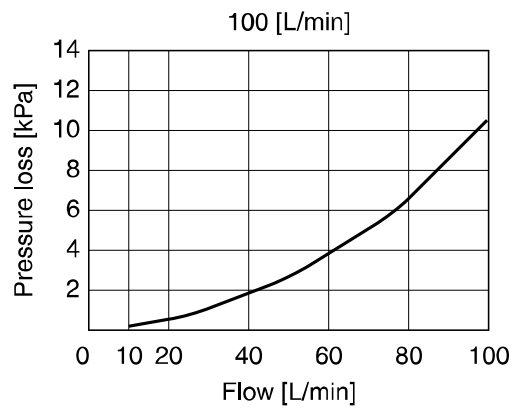
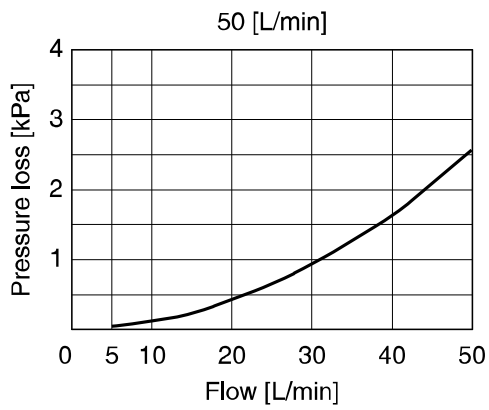
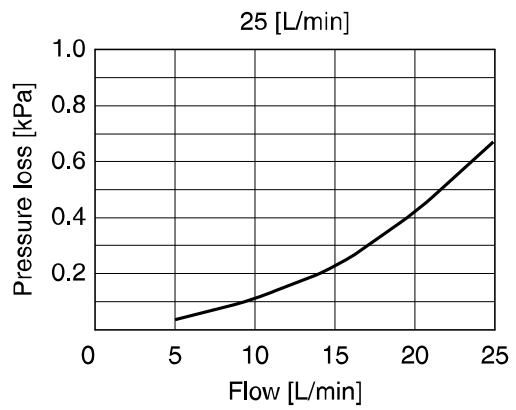
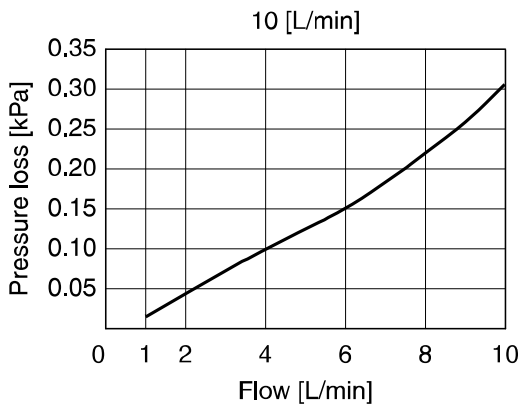

## ■Dimensions

PFM5##-(N)01/(N)02/F01-1/2

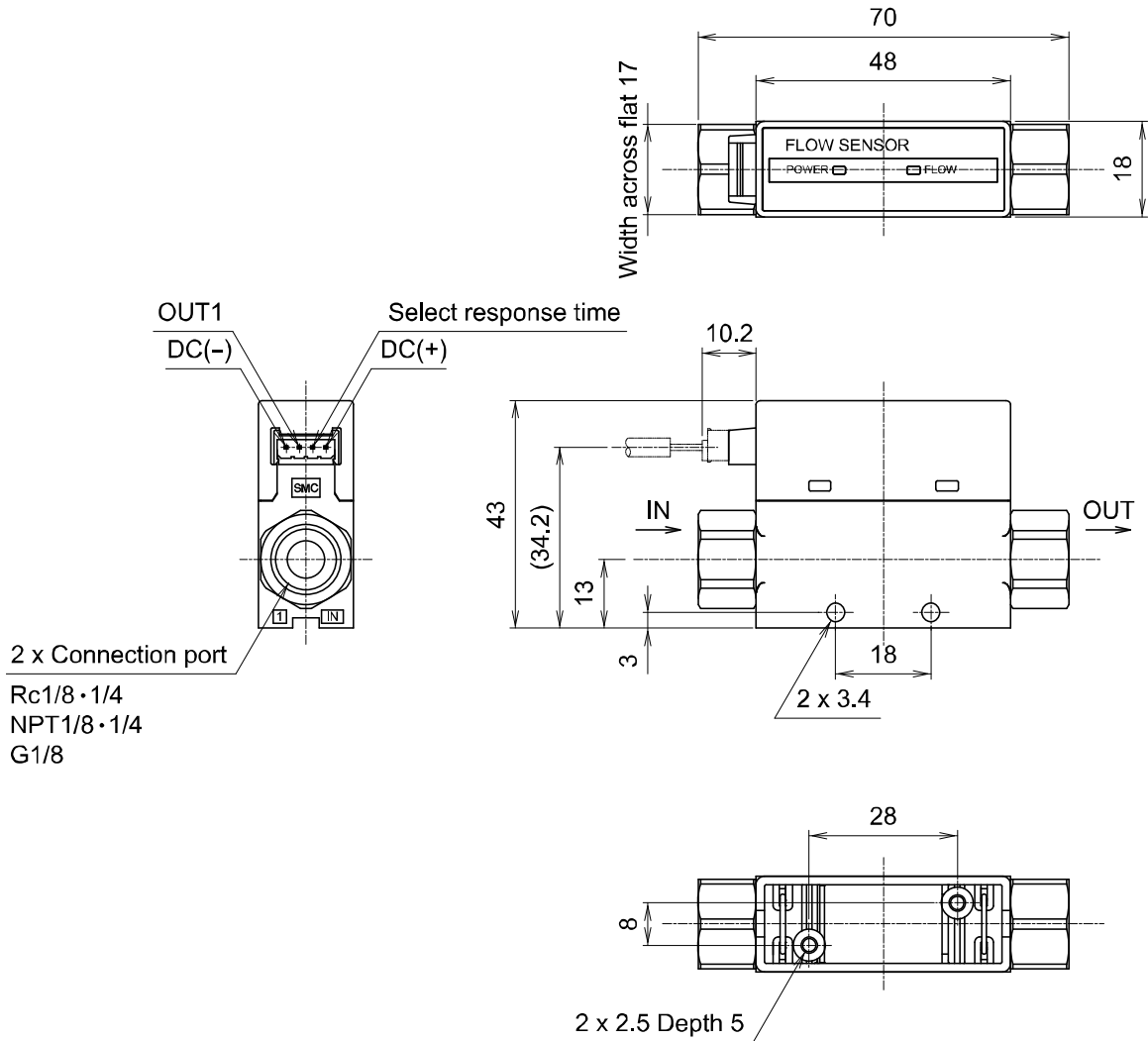

PFM5##-(N)01L/(N)02L/F01L-1/2

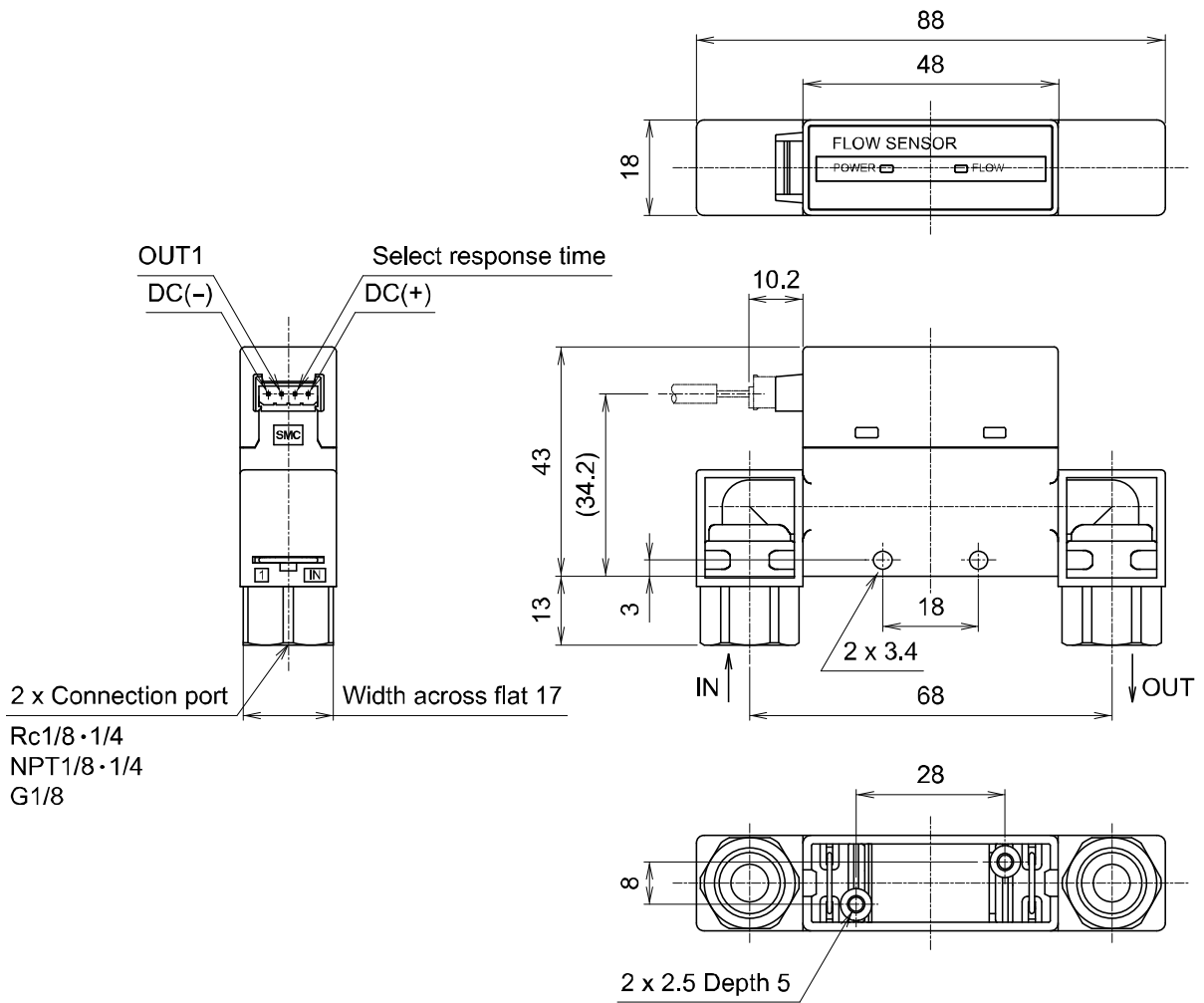

PFM5##S-(N)01/(N)02/F01-1/2

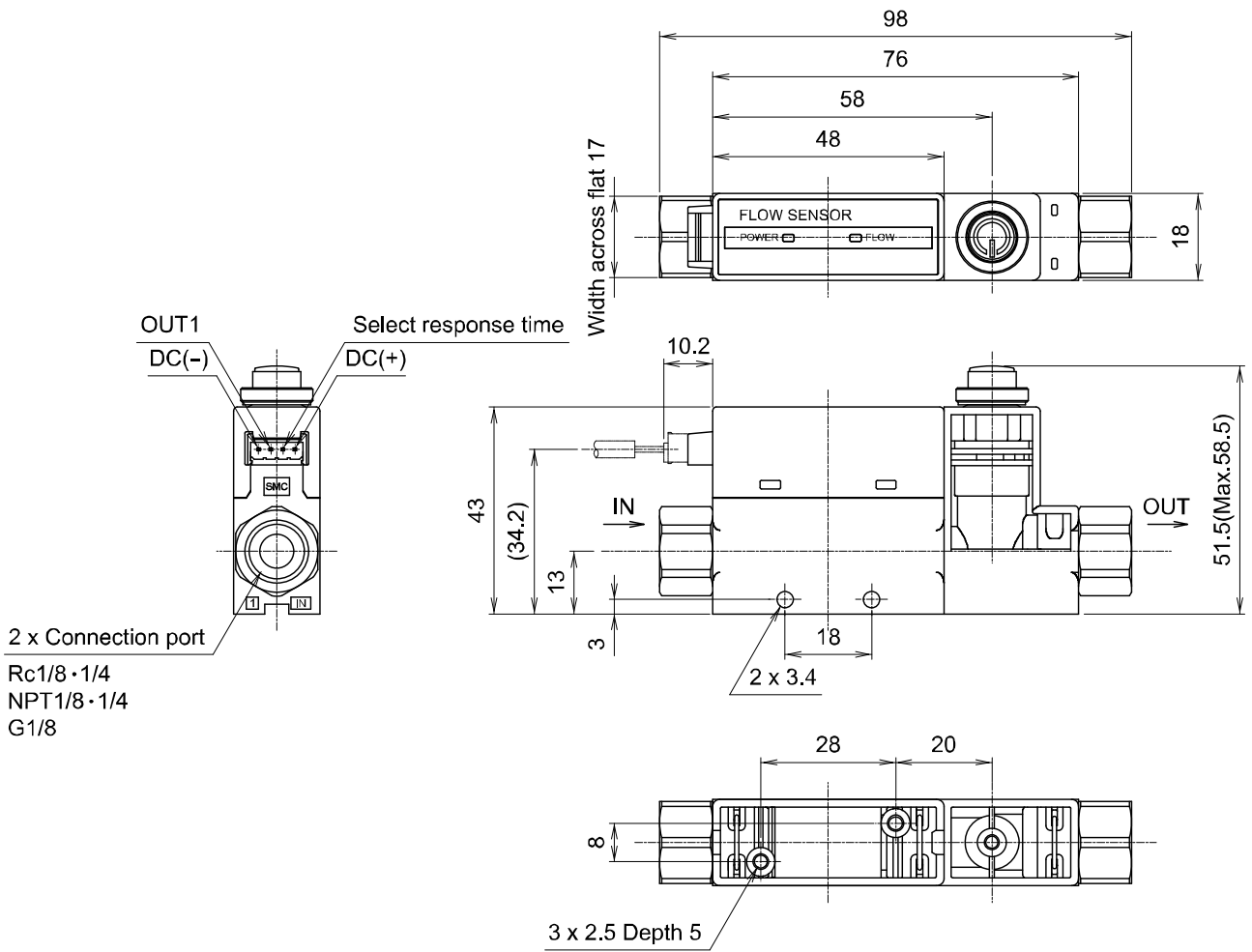



PFM5##-F02-1/2

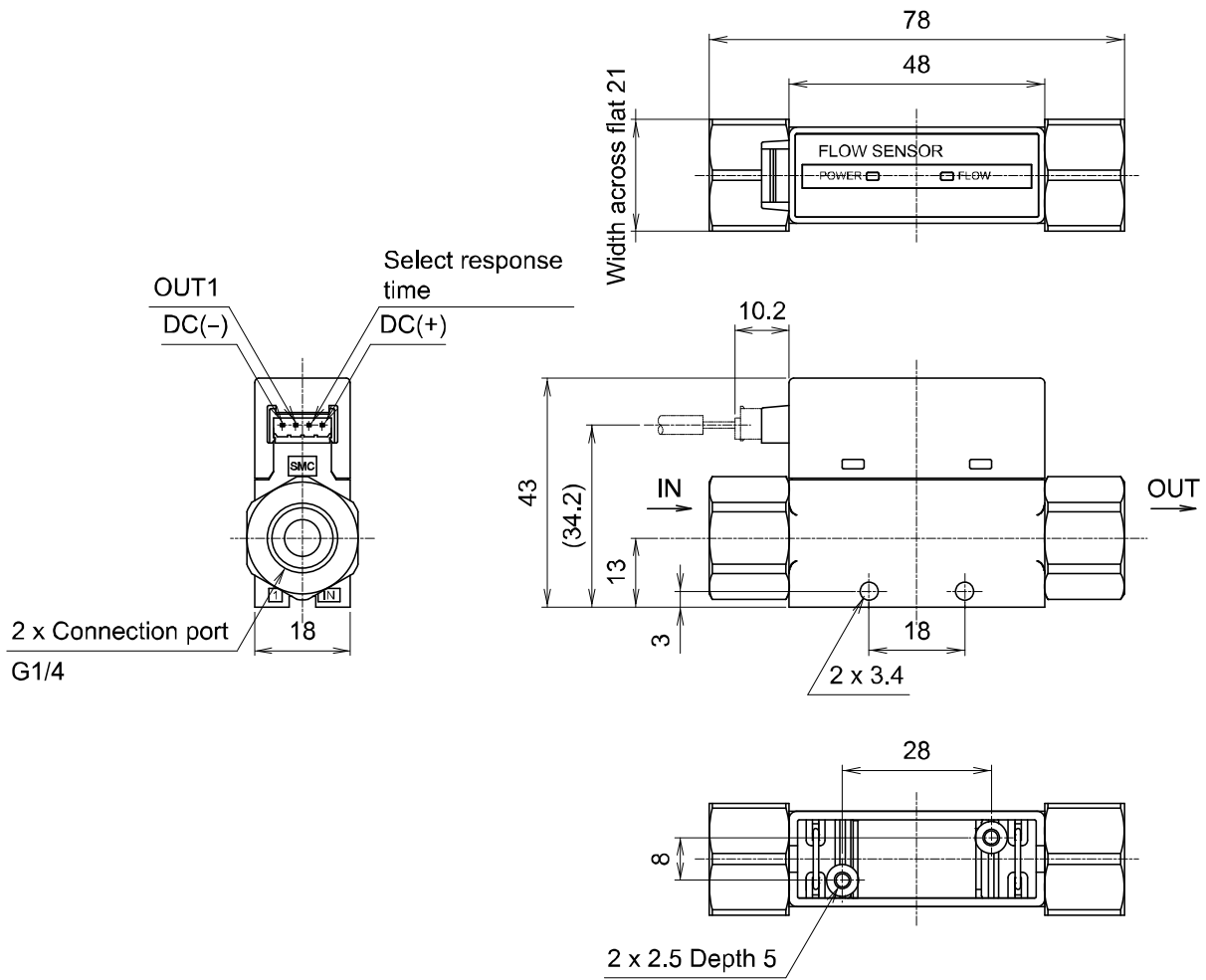



PFM5##S-F02-1/2

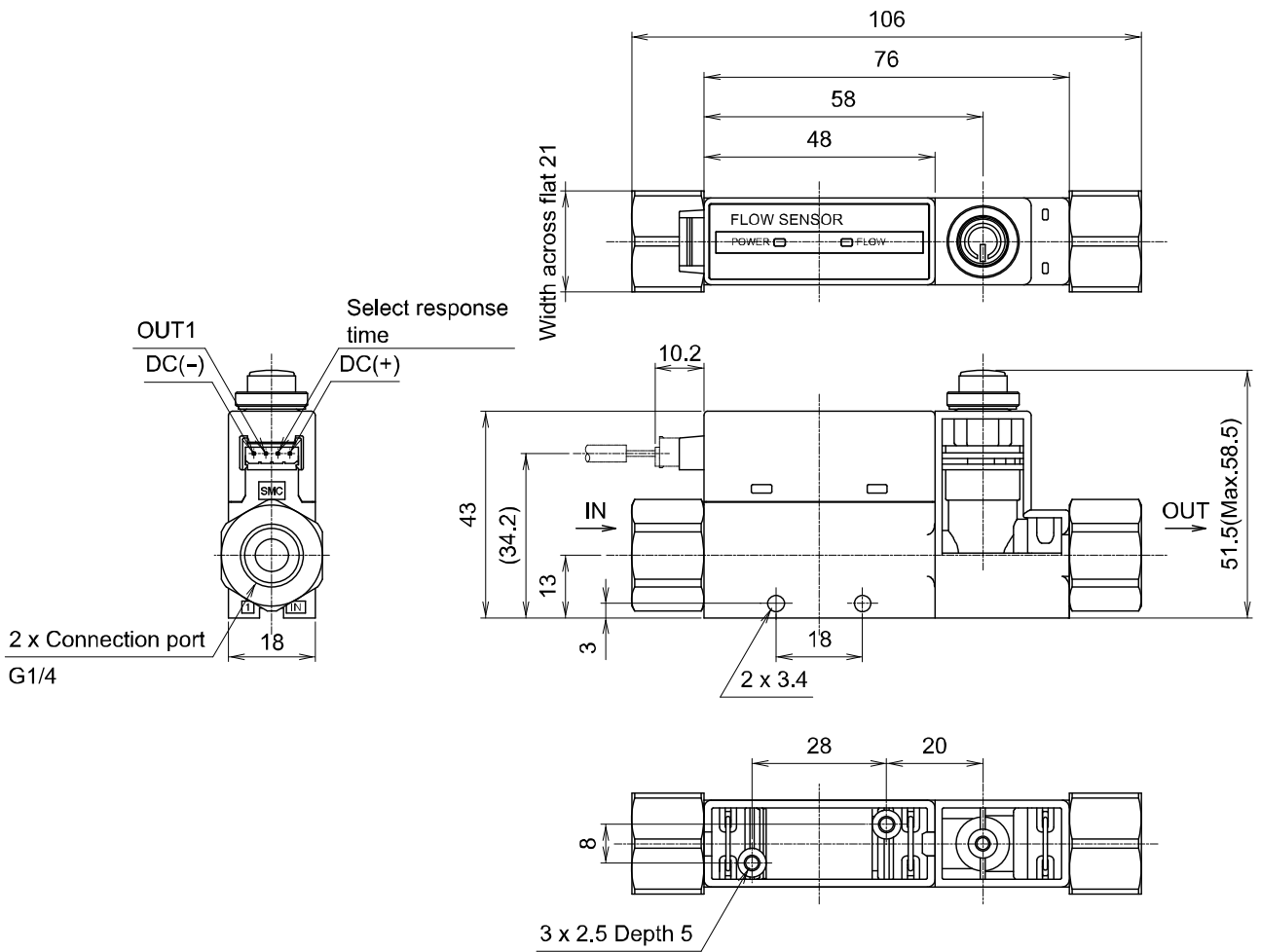



PFM5##S-F02L-1/2

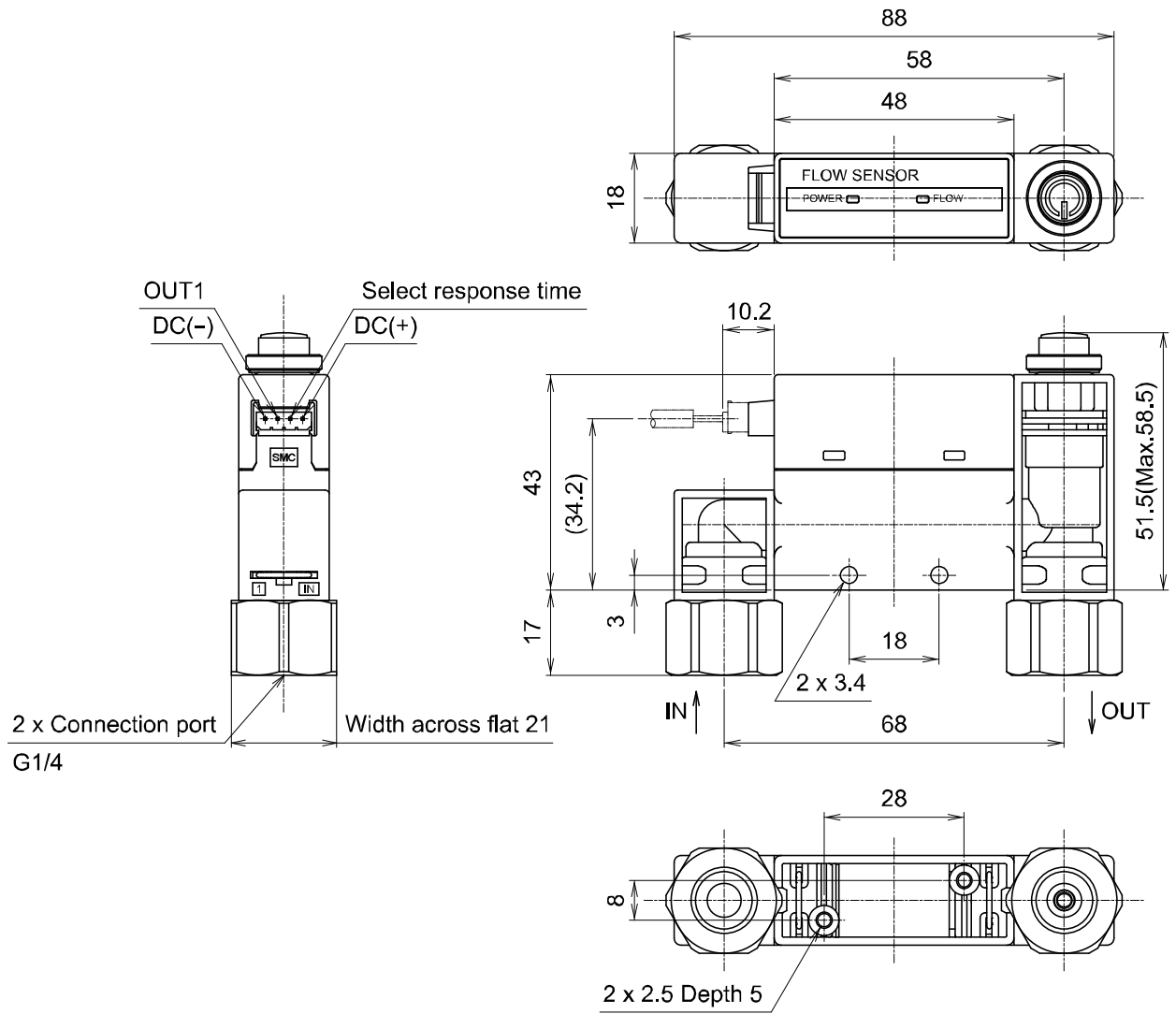

PFM5##-C/N#-1/2

A	Dimensions
C4	64.2
C6	64.6
C8	68
N7	64.6

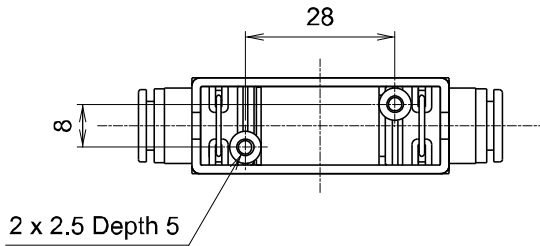
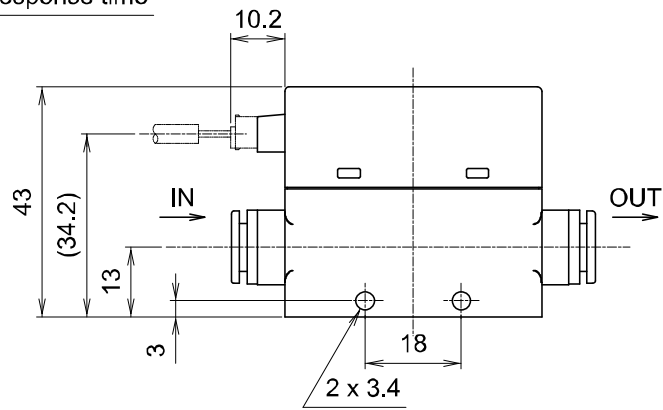
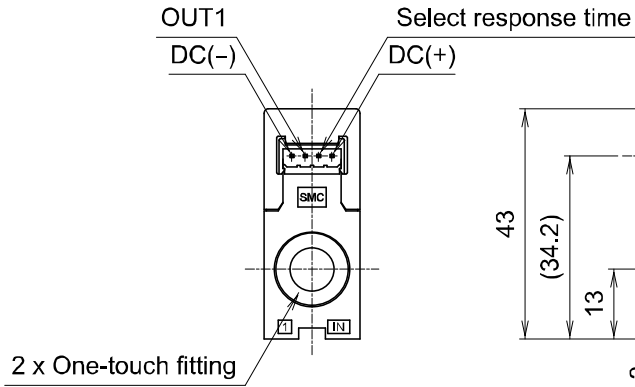
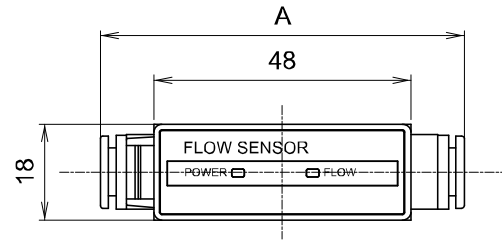

PFM5##-C/N#L-1/2

A	Dimensions
C4L	10.1
C6L	10.3
C8L	12
N7L	10.3

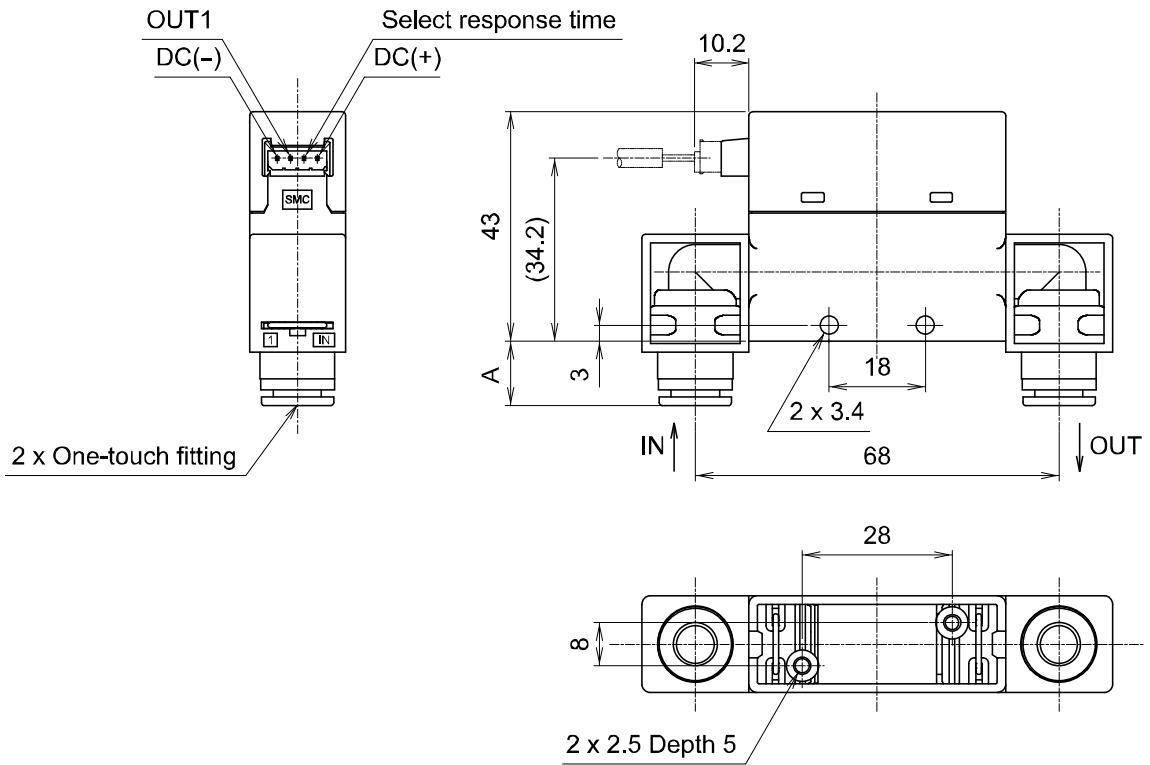
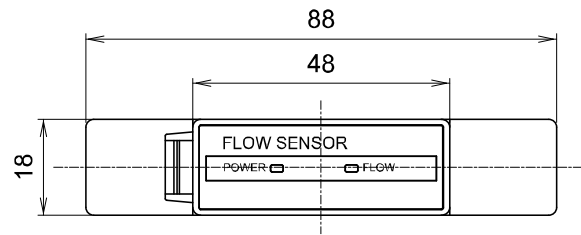

PFM5##S-C/N#-1/2

A	Dimensions
C4	92.2
C6	92.6
C8	96
N7	92.6

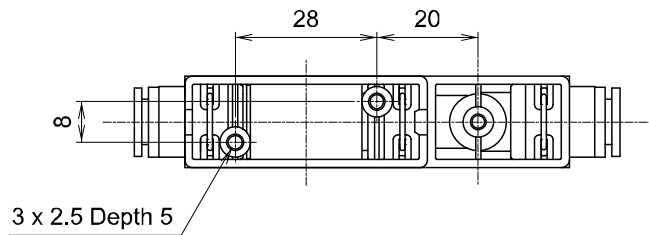
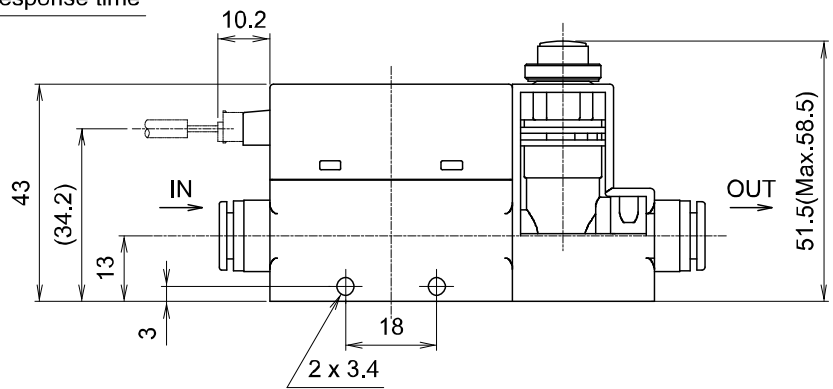
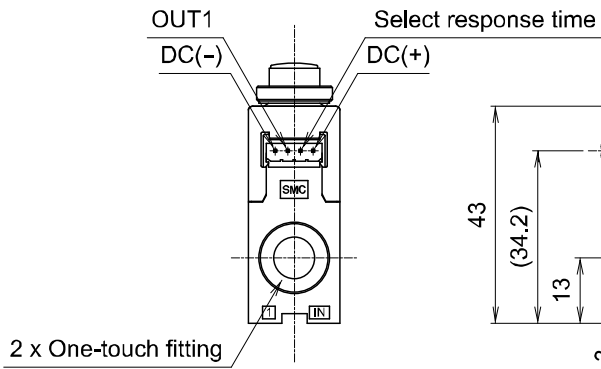
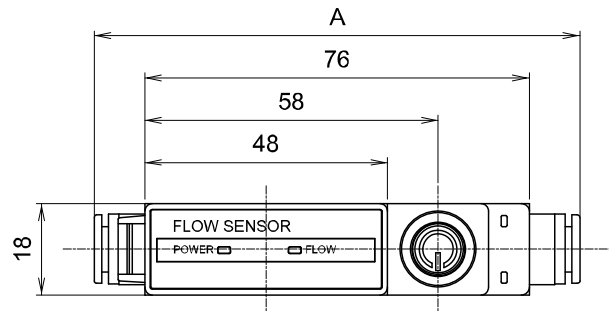



## Panel cut-out dimensions

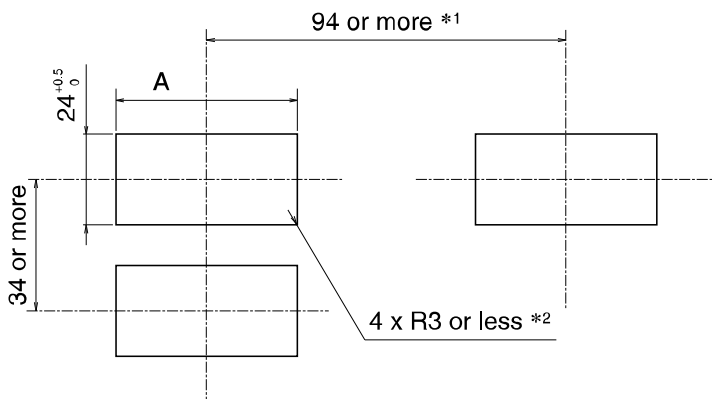

Flow adjustment valve	A
None	$54^{+0.5}_0$
With flow adjustment valve	$74^{+0.5}_0$

\*1: These are the minimum dimensions for bottom entry piping. If using straight entry piping, the material and tubing need to be taken into consideration when deciding panel cut-out spacing.

\*2: If a bend (R) is used, limit it to R3 or less.

\*3: Suitable for panel thickness of 1 to 3.2 mm.

## Bracket (ZS-33-M)

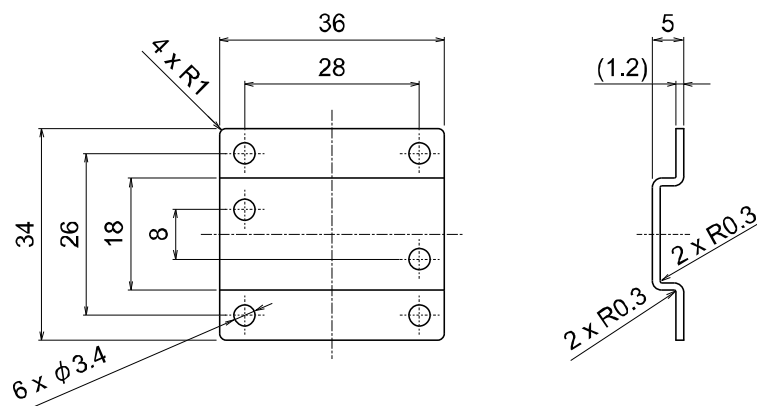

## Bracket (ZS-33-MS)

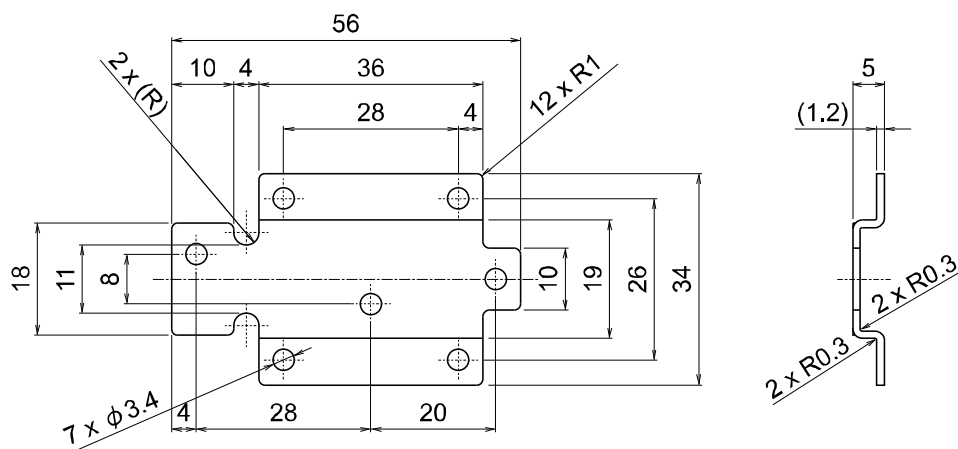

Lead wire and connector (ZS-33-D)

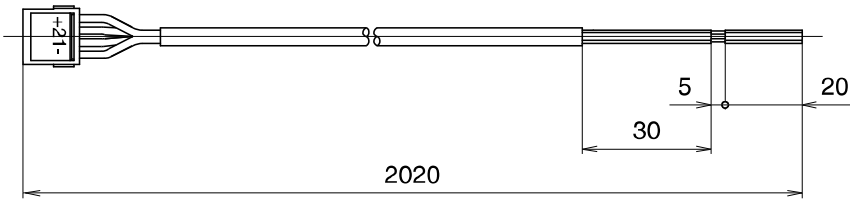

Connector cover (ZS-33-F)

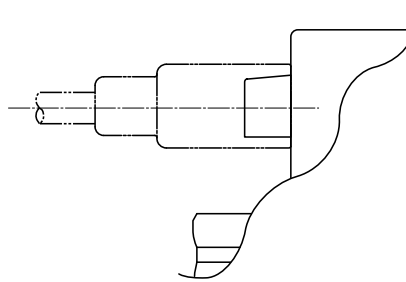
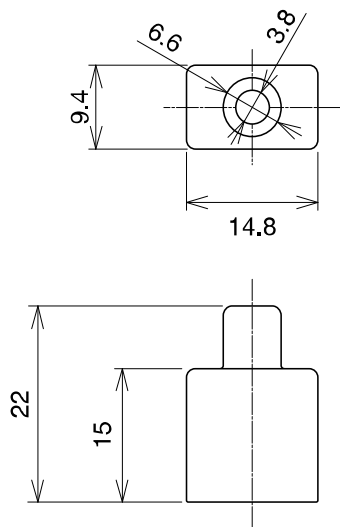

Attached the connector cover

#### Revision history

A: Contents revised in several places.  
B: Contents revised in several places.  
C: Modified errors in text.  
D: Contents are added.  
E: Contents revised in several places.  
F: Contents revised in several places.  
[September 2016]  
G: Contents are added. [February 2017]  
H: Contents revised in several places. [July 2018]  
I: Contents are added. [May 2019]  
J: Contents revised in several places. [July 2022]  
K: Contents revised in several places. [May 2024]

## SMC Corporation

Tel: + 81 3 5207 8249 Fax: +81 3 5298 5362

URL <https://www.smcworld.com>

---

Note: Specifications are subject to change without prior notice and any obligation on the part of the manufacturer.  
© SMC Corporation All Rights Reserved



No.PF※※-OMJ0016-K