



Operation Manual

PRODUCT NAME

4-channel Flow Monitor
( IO-Link compatible)

MODEL / Series / Product Number

PFG20#

SMC Corporation

Table of Contents

Safety Instructions	3
Model Indication and How to Order	9
Summary of Product parts	10
Definition and terminology	12
Mounting and Installation	15
Installation	15
Wiring	17
Internal circuit and wiring example	19
Outline of Settings	22
Initial Setting	23
F 0 Connection product, flow range, display unit, enable/disable IO-Link	23
3 Step Setting Mode	30
Simple Setting Mode	32
Function Selection Mode	33
Function selection mode	33
Default setting	33
F 1 Setting of OUT1	35
F 2 Setting of OUT2	40
F 3 Digital filter setting	43
F10 Sub display setting	44
F14 Zero cut-off setting	49
F20 External input setting	50
F30 Accumulated flow value hold setting	51
F80 Power saving mode	52
F81 Security code	53
F90 Setting of all functions	55
F95 Channel to channel copy function setting	57
F96 Sensor input display	58
F98 Output check	59
F99 Reset to default settings	66
Other Settings	67
IO-Link specifications	71
Outline of IO-Link function	71
Communication specifications	71
Process data	72
IO-Link parameter setting	76
Maintenance	90
Forgotten the security code	90
Troubleshooting	91
Specifications	102
Dimensions	105



Safety Instructions

These safety instructions are intended to prevent hazardous situations and/or equipment damage. These instructions indicate the level of potential hazard with the labels of “**Caution**,” “**Warning**” or “**Danger**.” They are all important notes for safety and must be followed in addition to International Standards (ISO/IEC)^{*)}, and other safety regulations.

*1) ISO 4414: Pneumatic fluid power - General rules and safety requirements for systems and their components
ISO 4413: Hydraulic fluid power - General rules and safety requirements for systems and their components
IEC 60204-1: Safety of machinery - Electrical equipment of machines - Part 1: General requirements
ISO 10218-1: Robots and robotic devices - Safety requirements for industrial robots - Part 1: Robots
etc.



Danger

Danger indicates a hazard with a high level of risk which, if not avoided, will result in death or serious injury.



Warning

Warning indicates a hazard with a medium level of risk which, if not avoided, could result in death or serious injury.



Caution

Caution indicates a hazard with a low level of risk which, if not avoided, could result in minor or moderate injury.



Warning

1. The compatibility of the product is the responsibility of the person who designs the equipment or decides its specifications.

Since the product specified here is used under various operating conditions, its compatibility with specific equipment must be decided by the person who designs the equipment or decides its specifications based on necessary analysis and test results. The expected performance and safety assurance of the equipment will be the responsibility of the person who has determined its compatibility with the product. This person should also continuously review all specifications of the product referring to its latest catalog information, with a view to giving due consideration to any possibility of equipment failure when configuring the equipment.

2. Only personnel with appropriate training should operate machinery and equipment.

The product specified here may become unsafe if handled incorrectly. The assembly, operation and maintenance of machines or equipment including our products must be performed by an operator who is appropriately trained and experienced.

3. Do not service or attempt to remove product and machinery/equipment until safety is confirmed.

1. The inspection and maintenance of machinery/equipment should only be performed after measures to prevent falling or runaway of the driven objects have been confirmed.
2. When the product is to be removed, confirm that the safety measures as mentioned above are implemented and the power from any appropriate source is cut, and read and understand the specific product precautions of all relevant products carefully.
3. Before machinery/equipment is restarted, take measures to prevent unexpected operation and malfunction.

4. Our products cannot be used beyond their specifications. Our products are not developed, designed, and manufactured to be used under the following conditions or environments. Use under such conditions or environments is not covered.

1. Conditions and environments outside of the given specifications, or use outdoors or in a place exposed to direct sunlight.
2. Use for nuclear power, railways, aviation, space equipment, ships, vehicles, military application, equipment affecting human life, body, and property, fuel equipment, entertainment equipment, emergency shut-off circuits, press clutches, brake circuits, safety equipment, etc., and use for applications that do not conform to standard specifications such as catalogs and operation manuals.
3. Use for interlock circuits, except for use with double interlock such as installing a mechanical protection function in case of failure. Please periodically inspect the product to confirm that the product is operating properly.



Safety Instructions

Caution

We develop, design, and manufacture our products to be used for automatic control equipment, and provide them for peaceful use in manufacturing industries.

Use in non-manufacturing industries is not covered.

Products we manufacture and sell cannot be used for the purpose of transactions or certification specified in the Measurement Act.

The new Measurement Act prohibits use of any unit other than SI units in Japan.

Limited warranty and Disclaimer/Compliance Requirements

The product used is subject to the following “Limited warranty and Disclaimer” and “Compliance Requirements”.

Read and accept them before using the product.

Limited warranty and Disclaimer

1. The warranty period of the product is 1 year in service or 1.5 years after the product is delivered, whichever is first.*2)

Also, the product may have specified durability, running distance or replacement parts. Please consult your nearest sales branch.

2. For any failure or damage reported within the warranty period which is clearly our responsibility, a replacement product or necessary parts will be provided.

This limited warranty applies only to our product independently, and not to any other damage incurred due to the failure of the product.

3. Prior to using SMC products, please read and understand the warranty terms and disclaimers noted in the specified catalog for the particular products.

***2) Vacuum pads are excluded from this 1 year warranty.**

A vacuum pad is a consumable part, so it is warranted for a year after it is delivered.

Also, even within the warranty period, the wear of a product due to the use of the vacuum pad or failure due to the deterioration of rubber material are not covered by the limited warranty

Compliance Requirements

1. The use of SMC products with production equipment for the manufacture of weapons of mass destruction (WMD) or any other weapon is strictly prohibited.

2. The exports of SMC products or technology from one country to another are governed by the relevant security laws and regulations of the countries involved in the transaction. Prior to the shipment of a SMC product to another country, assure that all local rules governing that export are known and followed.

Operator

- ◆ This operation manual is intended for those who have knowledge of machinery using pneumatic equipment, and have sufficient knowledge of assembly, operation and maintenance of such equipment. Only those persons are allowed to perform assembly, operation and maintenance.
- ◆ Read and understand this operation manual carefully before assembling, operating or providing maintenance to the product.

■ Safety Instructions

Warning

- Do not disassemble, modify (including changing the printed circuit board) or repair.
An injury or failure can result.
- Do not operate the product outside of the specifications.
Do not use for flammable or harmful fluids.
Fire, malfunction, or damage to the product can result.
Verify the specifications before use.
- Do not operate in an atmosphere containing flammable or explosive gases.
Fire or an explosion can result.
This product is not designed to be explosion proof.
- Do not use the product in a place where static electricity is a problem.
Otherwise it can cause failure or malfunction of the system.
- If using the product in an interlocking circuit:
 - Provide a double interlocking system, for example a mechanical system
 - Check the product regularly for proper operationOtherwise malfunction can result, causing an accident.
- The following instructions must be followed during maintenance:
 - Turn off the power supply
 - Stop the air supply, exhaust the residual pressure and verify that the air is released before performing maintenanceOtherwise an injury can result.

Caution

- Do not touch the terminals and connectors while the power is on.
Otherwise electric shock, malfunction or damage to the product can result.
- After maintenance is complete, perform appropriate functional inspections and leak tests.
Stop operation if the equipment does not function properly or there is a leakage of fluid.
When leakage occurs from parts other than the piping, the product might be faulty.
Disconnect the power supply and stop the fluid supply.
Do not apply fluid under leaking conditions.
Safety cannot be assured in the case of unexpected malfunction.

■ **NOTE**

- Follow the instructions given below when designing, selecting and handling the product.
 - The instructions on design and selection (installation, wiring, environment, adjustment, operation, maintenance, etc.) described below must also be followed.
 - *Product specifications
 - Use the specified voltage.
Otherwise failure or malfunction can result.
 - Use the specified flow sensor.
Otherwise the product may be broken and it will not be able to perform proper measurement.
 - Do not exceed the specified maximum allowable load.
Otherwise it can cause damage or shorten the lifetime of the product.
 - Design the product to prevent reverse current when the circuit is opened or the product is forced to operate for operational check.
Reverse current can cause malfunction or damage to the product.
 - Input data to the product is not deleted, even if the power supply is cut off.
(Writing time: 10,000 times, Data duration: 20 years after power off)
 - Reserve a space for maintenance.
Allow sufficient space for maintenance when designing the system.

●Product handling

*Installation

- Tighten to the specified tightening torque.

If the tightening torque is exceeded the mounting screws and brackets may be broken.

If the tightening torque is insufficient, the product can be displaced and loosen the mounting screws.

- Be sure to ground terminal FG when using a commercially available switch-mode power supply.
- Do not drop, hit or apply shock to the product.

Otherwise damage to the internal parts can result, causing malfunction.

- Do not pull the lead wire forcefully, not lift the product by pulling the lead wire.

(Tensile strength: 50 N maximum for power supply and output cable, 25 N maximum for sensor lead wire with connector).

Hold the body when handling to avoid the damage of the product which lead to cause the failure and malfunction.

- Never mount the product in a place that will be used as a scaffold during piping.

The product may be damaged if excessive force is applied by stepping or climbing onto it.

*Wiring

- Do not pull the lead wires. In particular, do not lift or carry the product by holding the cables once they are connected to the product.

Otherwise damage to the internal parts can result, causing malfunction or to be off the connector.

- Avoid repeatedly bending or stretching the lead wire, or placing heavy load on them.

If the lead wire can move, fix it near the body of the product.

The recommended bend radius of the lead wire is 6 times the outside diameter of the sheath, or 33 times the outside diameter of the insulation material, whichever is larger.

Replace the damaged lead wire with a new one.

- Wire correctly.

Incorrect wiring can break the product.

- Do not perform wiring while the power is on.

Otherwise damage to the internal parts can result, causing malfunction.

- Do not route wires and cables together with power or high voltage cables.

Otherwise the product can malfunction due to interference of noise and surge voltage from power and high voltage cables to the signal line. Route the wires (piping) of the product separately from power or high voltage cables.

- Confirm proper insulation of wiring.

Poor insulation (interference from another circuit, poor insulation between terminals, etc.) can lead to excess voltage or current being applied to the product, causing damage.

- Design the system to prevent reverse current when the product is forced to operate for operational check.

Depending on the circuit used, insulation may not be maintained when operation is forced, allowing reverse current to flow, which can cause malfunction and damage the product.

- Keep wiring as short as possible to prevent interference from electromagnetic noise and surge voltage.

Do not use a cable longer than 20 m.

Wire the DC(-) line(blue) as close as possible to the power supply.

*Environment

- Do not use the product in area that is exposed to corrosive gases, chemicals, sea water, water or steam.

Otherwise failure or malfunction can result.

- Do not use the product in an environment where the product is constantly exposed to water or oil splashes.

If the product is to be used in an environment containing oils or chemicals such as coolant or cleaning solvent, it may be adversely affected (damage, malfunction, or hardening of the lead wires).

- Do not use in an area where surges are generated.

If there is equipment which generates a large amount of surge (solenoid type lifter, high frequency induction furnace, motor, etc.) close to the product, this may cause deterioration or breakage of the internal circuit of the product. Avoid sources of surge generation and crossed lines.

- Do not use a load which generates surge voltage.
When a surge-generating load such as a relay or solenoid is driven directly, use a load with a built-in surge suppressor.
- The product is CE/UKCA marked, but not immune to lightning strikes. Take measures against lightning strikes in the system.
- Mount the product in a place that is not exposed to vibration or impact.
Otherwise failure or malfunction can result.
- Prevent foreign matter such as remnant of wires from entering the product.
Take proper measures for the remnant not to enter the product in order to prevent failure or malfunction.
- Do not use the product in an environment that is exposed to temperature cycle.
Heat cycles other than ordinary changes in temperature can adversely affect the inside of the product.
- Do not expose the product to direct sunlight.
If using in a location directly exposed to sunlight, shade the product from the sunlight.
Otherwise failure or malfunction can result.
- Keep within the specified ambient temperature range.
The ambient temperature range is 0 to 50 °C. Operation at low temperature (5 °C or less) may cause damage or operation failure due to frozen moisture in the air.
Protection against freezing is necessary.
Avoid sudden temperature change even within specified temperature.
- Do not operate close to a heat source, or in a location exposed to radiant heat.
Otherwise malfunction can result.

*Adjustment and Operation

- Turn the power on after connecting a load.
Otherwise it can cause excess current causing instantaneous breakage of the product.
- Do not short-circuit the load.
Although error is displayed when the load at the output part has a short circuit, generated over current may lead to the damage of the product.
- Do not press the setting buttons with a sharp pointed object.
It may damage the setting buttons.
- Warm up the product for 10 to 15 minutes first.
There will be a drift on the display of approximate $\pm 1\%$ immediately after the power supply is turned on, within 10 minutes.
- Perform settings suitable for the operating conditions.
Incorrect setting can cause operation failure.
For details of each setting, refer to page 23 to 70 of this manual.
- Do not touch the LCD during operation.
The display can vary due to static electricity.

*Maintenance

- Turn OFF the power supply before maintenance.
There is a risk of unexpected malfunction.
- Perform regular maintenance and inspections.
There is a risk of unexpected malfunction.
- Do not use solvents such as benzene, thinner etc. to clean the product.
They could damage the surface of the body and erase the markings on the body.
Use a soft cloth to remove stains. For heavy stains, use a cloth soaked with diluted neutral detergent and fully squeezed, then wipe up the stains again with a dry cloth.

Model Indication and How to Order

PFG20 **2** - **M**

I/O specification

Symbol	Content
0	NPN (5 outputs) + External input
1	PNP (5 outputs) + External input
2	IO-Link + NPN 4 outputs or NPN 5 outputs (SIO mode)
3	IO-Link + PNP 4 outputs or PNP 5 outputs (SIO mode)

Unit specification

Symbol	Content
Nil	With units selection function *1
M	Fixed SI unit *2

*1: The new Measurement Law prohibits the use of pressure switch with the units selection function in Japan. A unit label is attached.

*2: Fixed units Instantaneous flow: L/min
Accumulated flow: L

Option 3

Symbol	Content
Nil	Power supply/output cable (2 m)
N	No option

*5: Cable is shipped together with the product.

Option 2

Symbol	Content
Nil	No option
4C	Connector for sensor lead wire (4 pcs.) For PF#A/W
4D	Connector for sensor lead wire (4 pcs.) For PF2D

*4: Connector is shipped together with the product.

Option 1

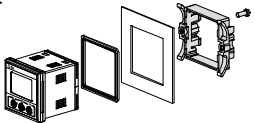
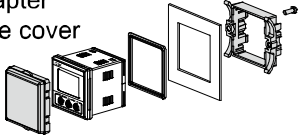
Symbol	Content
Nil	No option
A	Panel mount adapter 
B	Panel mount adapter + Front protective cover 

*3: Option is shipped together with the product.

○Accessories/Part numbers

Items	Part No.	Remarks
Power supply/output cable	ZS-26-L	Length 2 m
For PF2A5##, PF2W5##, PF3W5## Connector for sensor lead wire (e-con)	ZS-28-CA-4	1 pc., Finished outside diameter: Φ1.15 to Φ1.35 Cover colour: Blue
For PF2D5## Connector for sensor lead wire (e-con)	ZS-28-CA-2	1 pc., Finished outside diameter: Φ0.9 to Φ1.0 Cover colour: Red
Panel mount adapter	ZS-26-B	With set screw M3 x 8L (2 pcs.) and waterproof seal
Panel mount adapter + Front protective cover	ZS-26-C	With set screw M3 x 8L (2 pcs.) and waterproof seal
Front protective cover	ZS-26-01	-

Summary of Product parts

Names of individual parts

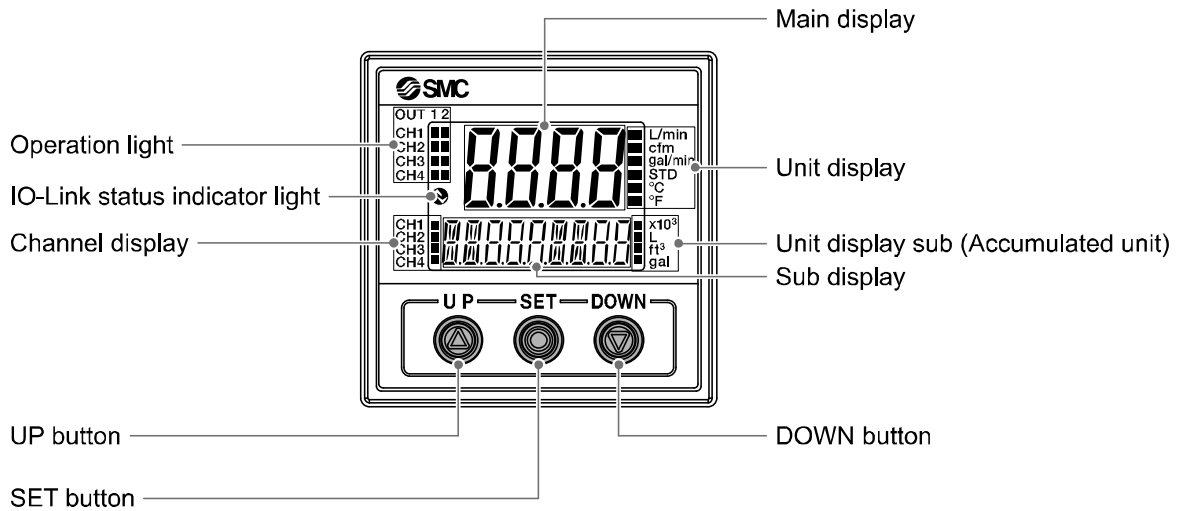

Operation light (Orange): Lit when OUT is ON.

Main display (Red/Green): Displays the current status of flow, setting mode, selected indication unit and error code.

UP button: Selects the channel and mode, and increases the ON/OFF set value.

DOWN button: Changes the sub display, selects the mode and decreases the ON/OFF set value.

SET button: Changes the mode and sets a set value.

Unit display (Red/Green): Lit ON the indicator of selected unit. For the Controller without unit selection function, the unit is fixed to SI (L/min, L).

LCD of corresponding unit turns on as follows:

Instantaneous flow unit Temperature unit	■ L/min	When L/min is selected
	■ cfm	When cfm is selected
	■ gal/min	When gal/min is selected
	■ STD	When STD is selected (reference condition, NOR when turned off)
	■ °C	When °C is selected
	■ °F	When °F is selected
Accumulated flow unit	■ x10 ³	The value of indicated value multiplied by 10 squared is the accumulation
	■ L	When L is selected
	■ ft ³	When Ft ³ is selected
	■ gal	When gal is selected





Channel display (Orange): Indicate the CH1 to CH4 that is selected at that time.



Sub display (left) (Orange): Displays items.

Sub display (right) (Orange): Displays set values, peak and bottom values.

IO-Link status indicator light: Displays OUT1 output communication status (SIO mode, start-up mode, Pre-operation mode, operation mode) and presence of communication data.

●IO-Link indicator light operation and display

Communication with master	IO-Link status indicator light	Status			Sub screen display *1	Content
						
Yes		IO-Link mode	Correct	Operate	Mode OPE	Normal communication status (Reading of measurement value)
				Start up	Mode STRT	When communication starts up.
				Preoperate	Mode PRE	
	Abnormal		Version does not match	Er 15 V 1.0	Version of master and IO-Link does not match *2	
Lock			Mode LOK	Back-up and re-store required due to data storage lock		
No		Communication shut-off			Mode STRT Mode PRE Mode OPE	Correct communication was not received for <u>1 second or more.</u>
		SIO mode			Mode SIO	General switch output

LCD display: "O" OFF, "" Flashing, "" ON

*1: "ModE - - -" is displayed when selecting the modes on the sub screen.

*2: When the product is connected to the master with version "V1.0", error Er15 is generated.

■ Definition and terminology

	Term	Definition
A	Accumulated flow	The total amount of fluid that has passed through the device. If an instantaneous flow of 100 L/min continues for 5 minutes, the accumulated flow will be $5 \times 100 = 500$ L.
	Accumulated pulse output	A type of output where a pulse is generated every time a predefined accumulated flow passes. It is possible to calculate the total accumulated flow by counting the pulses.
	Accumulated-value hold time	A function to store the cumulative flow value in the product's internal memory at certain time intervals. Reads the memory data when power is supplied. Accumulation of data begins with the value read at the moment power is supplied. The time interval for memorizing is 5 minutes.
	Analogue output	Outputs a value proportional to the flow rate. When the analogue output is in the range 1 to 5 V, it will vary between 1 to 5 V according to the rate of flow. The same for analogue output of 0 to 10 V or 4 to 20 mA.
B	Bottom value display (mode)	Shows the minimum value from when the power was supplied to the current time.
C	Chattering	The problem of the switch output turning ON and OFF repeatedly around the set value at high frequency due to the effect of pulsation.
D	Delay time	The setting time from when the input signal reaches the set value, to when the ON-OFF output actually begins working. Delay time setting can prevent the output from chattering.
	digit (Min. setting unit)	Shows how precisely the flow can be displayed or set by the digital flow switch. When 1 digit = 1 L/min, the flow is displayed in increments of 1 L/min, e.g., 1, 2, 3, ..., 99, 100.
	Digital filter	Function to add digital filtering to the fluctuation of input value. Smooth the fluctuation of displayed value for sharp start up or fall of the flow. When the function is valid, digital filtering is reflected to the ON/OFF of the switch output. Output chattering or flicker in the measurement mode display can be reduced by setting the digital filter. The response time indicates when the set value is 90% in relation to the step input.
	Display accuracy	Shows The maximum deviation between the displayed measurement value and the true value.
	Display colour	Indicates the colour of the number of digital display. Always green, always red, green (switch OFF) → red (switch ON), red (switch OFF) → green (switch ON) are available.
	Display resolving power	Indicate in how many the rated flow range can be divided to display. (Example: When the value can be displayed down to 1 L/min for the product for 0 to 100 L/Min, the resolution is 1/100)
E	Error displayed	The code number displayed, identifying the error detected by the self-diagnosis function of product. Refer to "Error indication function" on page 100 for details of the errors.
	Error output	Switches the switch output to ON/OFF when an error is displayed. Refer to "List of output modes" on page 39 for operating conditions. Refer to "Error indication function" on page 100 for details of the errors.

	Term	Definition
F	Function selection mode	A mode in which setting of functions is performed. If any function settings need to be changed from the factory default, each setting can be selected with "F*". The setting items are: output mode, output type, display colour, digital filter, reverse display, zero-cut off display or no display, display value fine adjustment, use of power saving mode, security code, etc.
	F.S. (Full span, Full scale)	Stands for "full span" or "full scale", and indicates varied display value and analogue output range at rated value. For example, when analogue output is 1 to 5 V, F.S. = 5[V] - 1[V] = 4[V], (ref. 1%F.S. = 4[V] x 1% = 0.04[V])
H	Hysteresis	The difference between ON and OFF points used to prevent chattering. Hysteresis can be effective in avoiding the effects of pulsation.
	Hysteresis mode	Mode where the switch output will turn ON when the flow is greater than the set value, and will turn off when the flow falls below (set value – hysteresis value). (Refer to "List of output modes" on page 39.)
I	Instantaneous flow	The flow passing per unit of time. If it is 10 L/min, there is a flow of 10 L passing through the device in 1 minute.
	Insulation resistance	Insulation resistance of the product. The resistance between the electrical circuit and the case.
	Internal voltage drop	The voltage drop across the product (and therefore not applied to the load), when the switch output is ON. The voltage drop will vary with load current, and ideally should be 0 V.
K	Key-lock function	This function prevents the set value from being changed by mishandling.
M	Maximum applied voltage	The maximum voltage that can be connected to the output of an NPN device.
	Maximum load current	The maximum current that can flow to the output (output line) of the switch output.
	Measurement mode	Operating condition in which flow and temperature is being detected and displayed, and the switch function is working.
N	Normal output	One of the switch output types. In hysteresis mode the switch output is turned ON when measurement value equal to or greater than the switch output set value is detected. In window comparator mode, the switch output is turned ON when measurement value between the switch output set values (P1L to P1H) is detected. (Refer to "List of output modes" on page 39.)
O	Operating humidity range	Humidity range in which the product can operate.
	Operating temperature range	Ambient temperature range in which product is operable.
	Operation light	A light that turns on when the switch output is ON.
	Operation mode	Either hysteresis mode or window comparator mode can be selected.
	Output mode	Hysteresis mode, window comparator mode, Accumulated output mode, Accumulated pulse output mode, Error output or Output OFF can be selected. Refer to "List of output modes" on page 39 for operating conditions.

	Term	Definition
P	Peak value display (mode)	Shows the maximum value from when the power was supplied to the current time.
	Power saving mode	Operating mode in which the digital display turns off and power consumption is reduced.
	Pressure characteristics	Indicates the change in the display value and analogue output when fluid pressure changes.
	Proof pressure	Pressure limit that if exceeded will result in mechanical and/or electrical damage to the product.
R	Rated pressure range	The pressure range within which the product will meet all published specifications.
	Repeatability	Reproducibility of the display value, when the measured quantity is repeatedly increased and decreased.
	Reversed output	One of the switch output types. In hysteresis mode the switch output is turned ON when flow less than or equal to the switch output set value is detected. In window comparator mode, the switch output is turned ON when flow is outside the switch output set values (n1L to n1H) is detected. (Refer to "List of output modes" on page 39.)
S	Smallest settable increment	The resolution of set and display values. If the minimum setting unit is 2 L/min, the display will change in 2 L/min steps, e.g. 30.....32.....34 L/min.
	Standard condition	The flow which is converted to the volume at 0 °C and 101.3 kPa (absolute pressure). [nor] indicates that the product is standard condition.
	Set flow range	The flow range that can be set for switch output.
	Set temperature range	The switch output range that can be set for temperature.
	Switch operating	The operation principle of the switch output. Normal output and reverse output can be selected. Refer to "List of output modes" on page 39 for operating conditions.
	Switch output	Output type that has only 2 conditions, ON or OFF. When in the ON condition an indicator light will show, and any connected load will be powered. When in the OFF condition, there will be no indicator light and no power supplied to the load.
T	Temperature characteristics	Indicates the change in the display value caused by ambient temperature changes.
U	Units selection function	A function to change the units in which the measured flow value is displayed. The display units can only be changed if the product is equipped this function. It is not possible to purchase the product with this function if the product is used in Japan. The product for Japan is displayed in SI only.
W	Window comparator mode	An operating mode in which the switch output is turned on and off depending on whether the measurement value is inside or outside the range of two set values. (Refer to "List of output modes" on page 39.)
	Withstand voltage	A measure of the product's resistance to a voltage applied between the electrical circuit and case. Durability in withstanding voltage. The product may be damaged if a voltage over this value is applied. (The withstand voltage is not the supply voltage used to power the product.)

Mounting and Installation

■ Installation

○ Mounting by panel mount adapter

- Fix the panel mount adapter to the Controller with the set screws M3 x 8L (2 pcs.) as attached.
- Panel mount adapter (Model: ZS-26-B)
- Panel mount adapter + Front protective cover (Model: ZS-26-01)

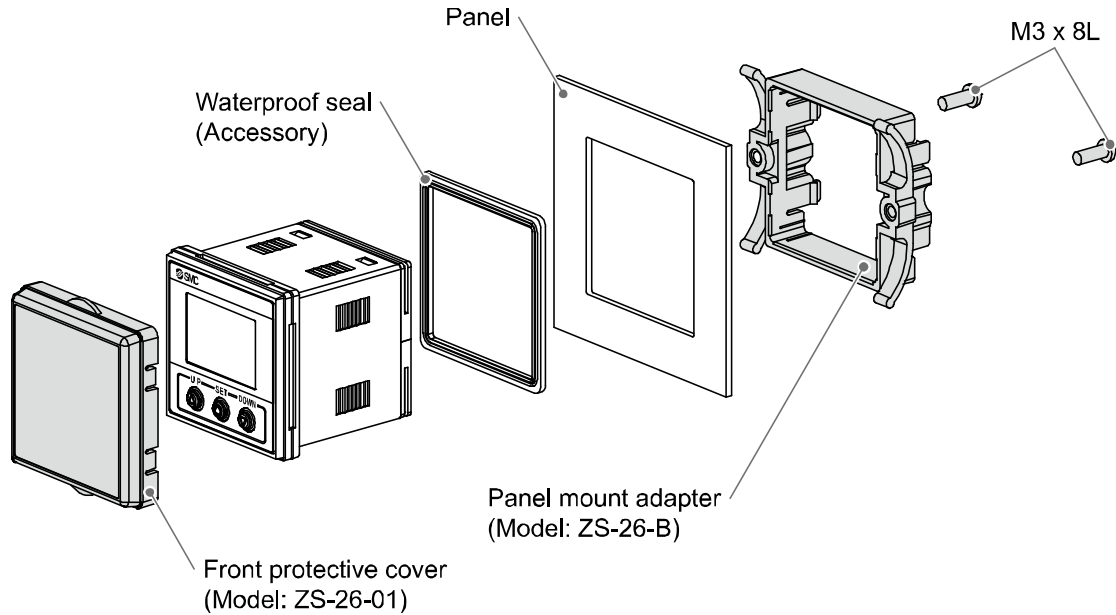

*: The panel mount adapter can be rotated by 90 degrees for mounting.

*: Front panel of this Controller meets IP65. However, if the panel mount adapter is hold enough with screw and the instrument is not seated correctly, water might enter. Screw shall be tightened 1/4 to 1/2 turns more after touched correctly.

○ Panel cutout dimension

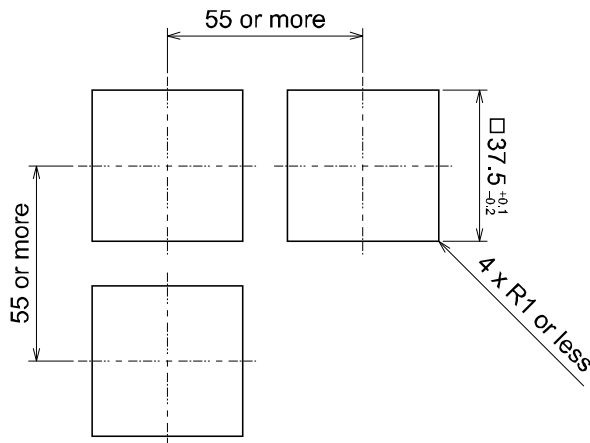

*: Panel thickness 0.5 to 8 mm

Notice when removing to the controller

- The Monitor with the panel mount adapter can be removed from facility after removing two screws as shown in a figure, by making insert the suitable thin card for the hook of both the sides, pull a panel mount adapter to the front, and remove it. If panel mount adapter is drawn forward with hook caught, the adapter and Monitor may be damaged.

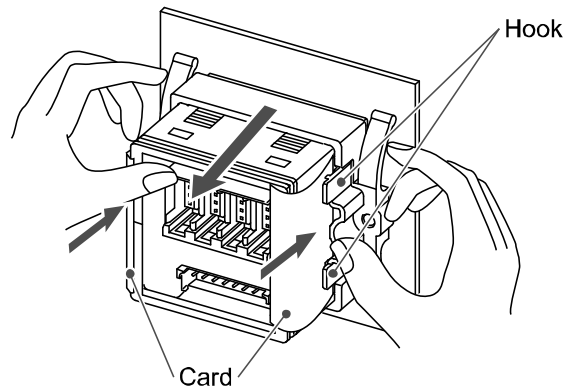

■Wiring

○Wiring connections

- Connections should be made with the power supply turned off.
- Use a separate route for the product wiring and any power or high voltage wiring. Otherwise, malfunction may result due to noise.
- If a commercially available switching power supply is used, be sure to ground the frame ground (FG) terminal. If the switching power supply is connected for use, switching noise will be superimposed and it will not be able to meet the product specifications. In that case, insert a noise filter such as a line noise filter/ferrite between the switching power supplies or change the switching power supply to the series power supply.

○Attaching the connector to the lead wire

- Strip the sensor wire as shown. Do not cut the insulator.

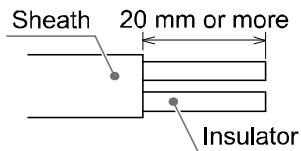

- Insert the corresponding wire colour shown in the table into the pin number printed on the sensor connector, to the bottom.

Pin No.	Wire colour of PF2#5##	Wire colour of PF3W5##
1	Brown	Brown
2	(NC)	(NC)
3	Blue	Blue
4	White	Black

- Check that the above preparation has been performed correctly, then part A shown should be pressed in by hand to make temporary connection.

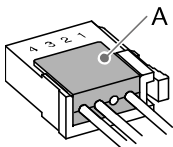

- Part A should then be pressed in using a suitable tool, such as pliers.

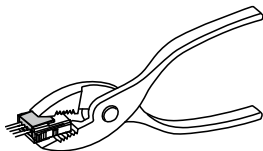

- Re-use cannot be performed once it connects the connector for sensor connection completely. When the connection fails or a pin is miswired, please use a new connector for sensor connection.
- When the sensor is not connected correctly, [LLL] will be displayed.

○Connector

Connecting/Disconnecting

- When connecting the connector, insert it straight onto the pin and lock the connector into the square groove in the housing until connector clicks.
- When removing the connector, press down the lever with your thumb and pull the connector straight out.

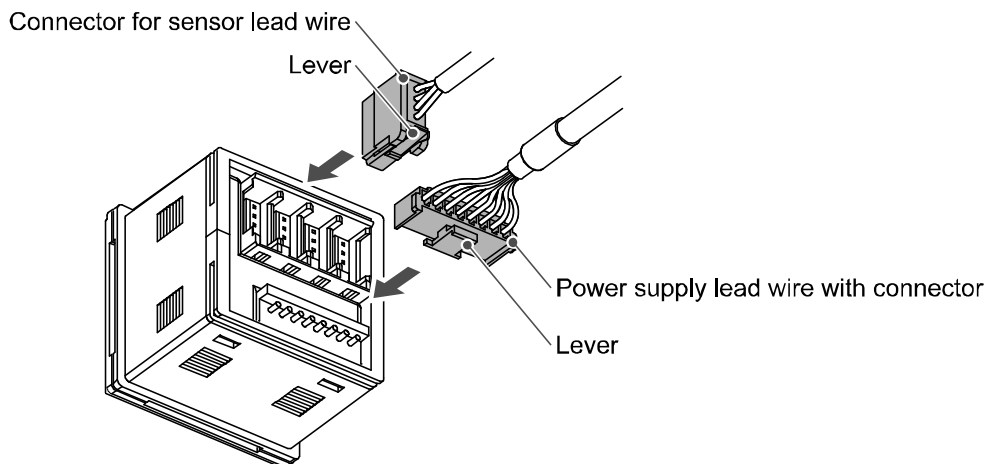

Pin No. of the connector

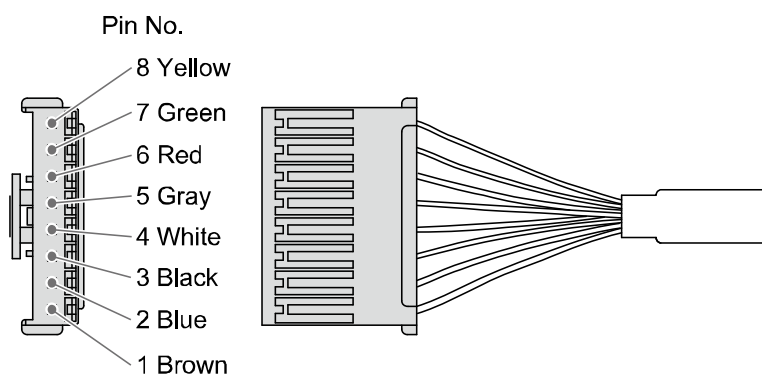

PIN number	Terminal name
1	DC(+) (L+)
2	DC(-) (L-)
3	CH1_OUT1 (C/Q)
4	CH1_OUT2
5	CH2_OUT1
6	CH3_OUT1
7	CH4_OUT1
8	FUNC (NC)

*() is for when using as IO-Link

Internal circuit and wiring example

Output specification

When the lead wire with SMC power and output lead wire (Model: ZS-26-L) is used, the colours of wire (Brown, Blue, White, Gray, Red, Green Yellow) will apply as shown on circuit diagram.

PFG200-#

•NPN open collector 5 output + External input

Max. applied voltage: 30 V, Load current 80 mA

Internal voltage drop: 1.5 V or less

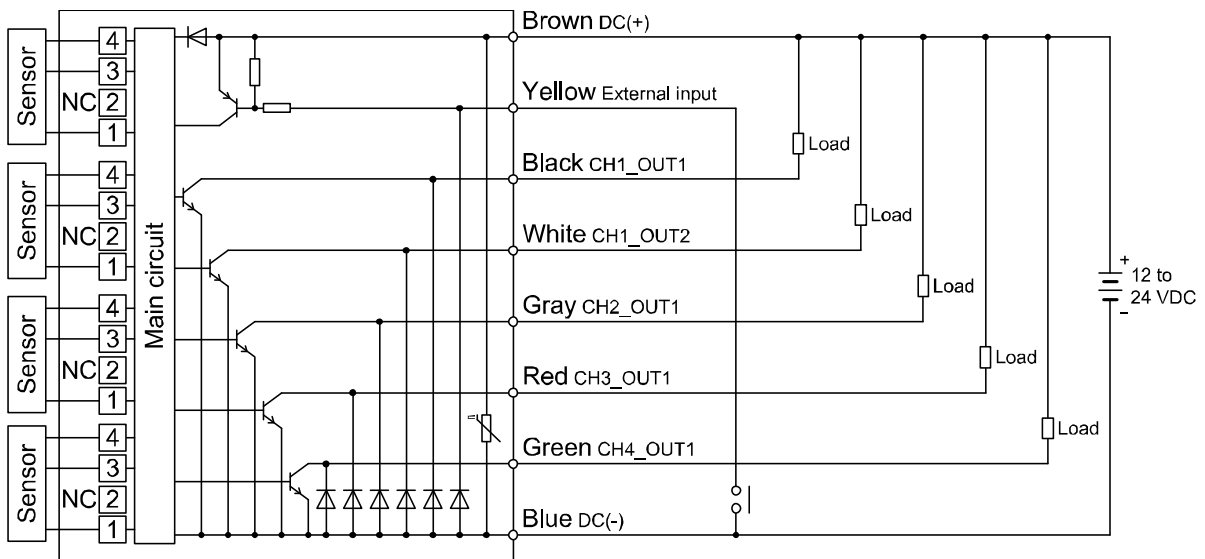

PFG201-#

•NPN open collector 5 output + auto-shift 1 output

Load current 80 mA

Internal voltage drop: 1.5 V or less

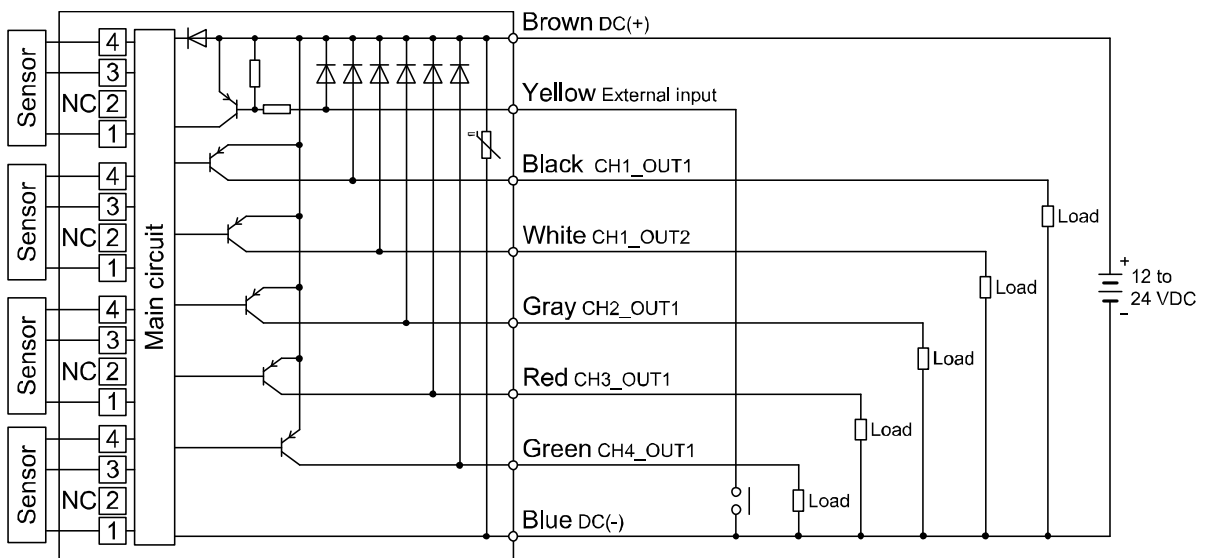

PFG202-#

•IO-Link/NPN open collector 1 output + NPN open collector 4 output specification

•When used as an IO-Link device

Max. applied voltage: 30 V, Load current 80 mA

Internal voltage drop: 1.5 V or less

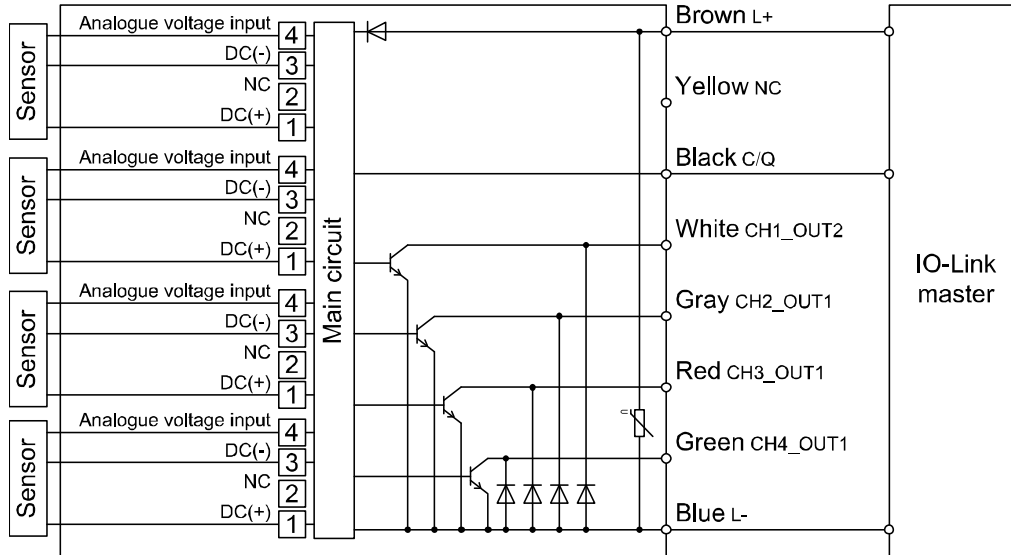

•When used as a switch output device

Max. applied voltage: 30 V, Load current 80 mA

Internal voltage drop: 1.5 V or less

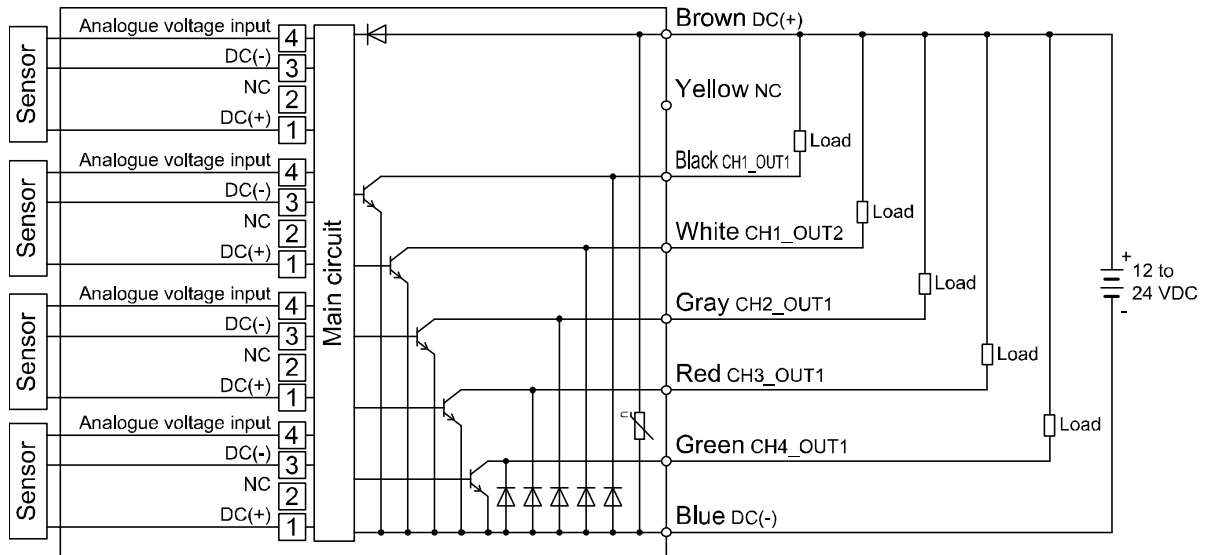

PFG203-#

•IO-Link/PNP open collector 1 output + PNP open collector 4 output specification

•Used as IO-Link device

Load current 80 mA

Internal voltage drop: 1.5 V or less

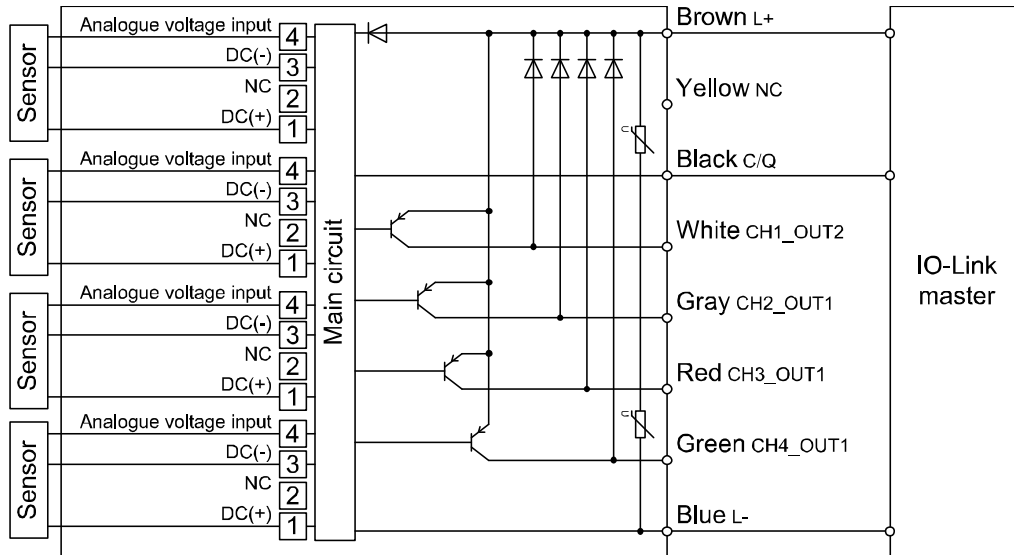

•When used as a switch output device

Load current 80 mA

Internal voltage drop: 1.5 V or less

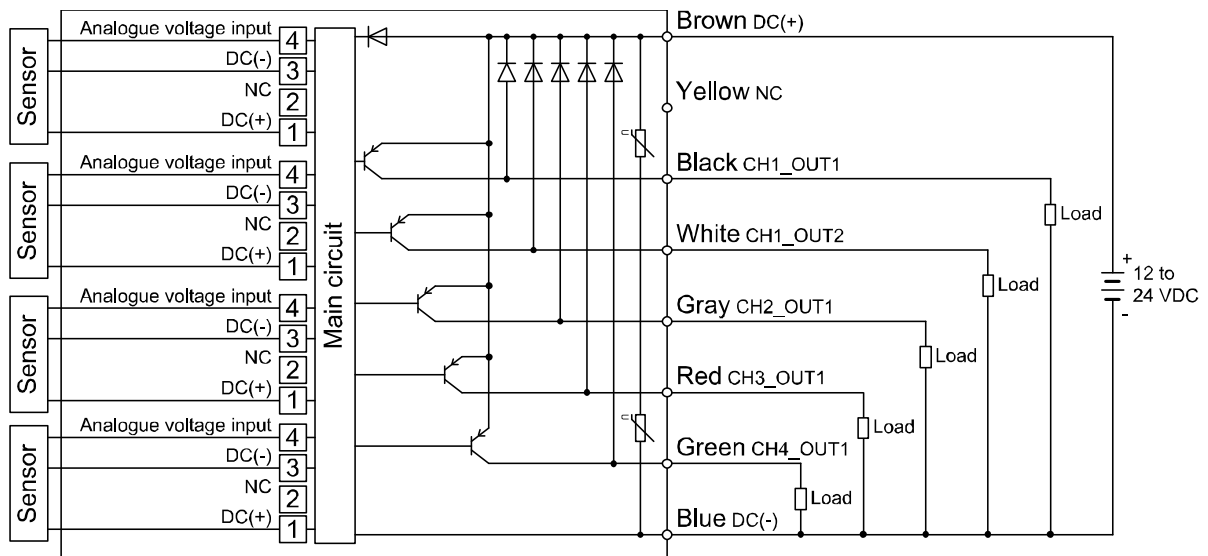

Outline of Settings

Power is supplied



The product code is displayed for approximately 3 sec. after supplying power.
After that, measurement mode is displayed.



[Initial Setting]

(Function selection mode [F 0]) (Refer to page 23)
Set the flow range, and display unit of the connected sensor.



[Measurement mode]

Detects the flow after power is supplied, and indicates the display and switch operating status. This is the basic mode; other modes should be selected for set-point changes and other function settings.

Measurement mode screen

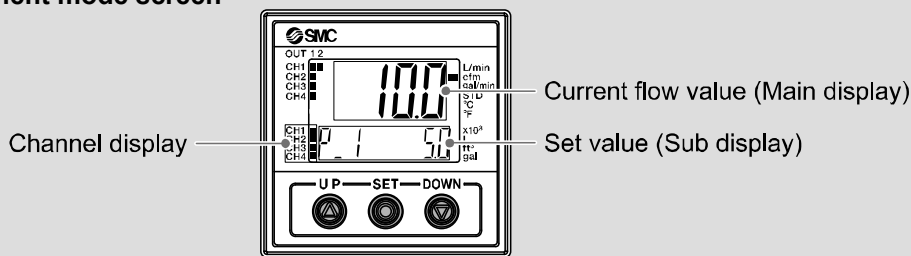

Channel selection

In measurement mode, the channel can be changed by pressing the UP button.

Measurement mode display and setting are set for each channel.

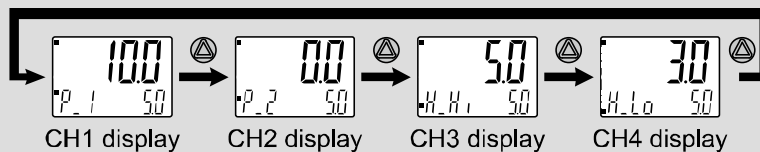

Press the SET button once.

[3 step setting mode]
Set either of set value or hysteresis.
(Refer to page 30)



Press the SET button between 1 and 3 sec.

[Simple setting mode]
Select the set value, hysteresis and delay time.
(Refer to page 32)



Press the SET button between 3 and 5 sec.

[Function selection mode]
Change the function settings.
(Refer to page 33)



Press the DOWN button once.

[Sub display setting]
(Refer to page 45)



[Other Settings]

- Channel scan function
- Key-lock function (Refer to page 67)

*: The outputs will continue to operate during setting.

*: If a button operation is not performed for a certain time during the setting, the display will flash.

(This is to prevent the setting from remaining incomplete if, for instance, an operator were to leave during setting.)

*: 3 step setting mode, simple setting mode and function selection mode settings are reflected each other.

Initial Setting

■ [F 0] Connection product, flow range, display unit, enable/disable IO-Link

Set the connection sensor, flow range, and display unit.

Measurement mode

↓ Press the UP button to select the channel.
Press the SET button between 3 and 5 sec.

Displays the [F 0] Connection product, flow range, display unit, and enable/disable IO-Link.



Press the SET button. ↓ Move on to the setting of connection product.

Setting of connection product

A function to set the product to connect to the selected channel.

Press the UP or DOWN button to select the connection product.

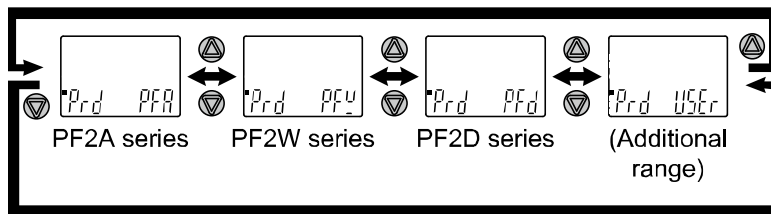

↓ [PFA], [PFW] or [PFd] is selected
Press the SET button and move on to the setting of connection sensor.

↓ [USER] is selected
Press the SET button and move on to the setting of minimum unit of additional range.

Refer to page 25.

Setting of connection sensor

Select the sensor to connect.

*: This setting is available only when [PFW] is selected as the connection product.
This item will not be displayed when another product is selected.



Item	Display	Content
Selection of connection sensor	[FLOW]	Flow
	[tEMP]	Temperature

Press the SET button to set. ↓ Move on to the setting of flow range.



Setting of flow range

Select the flow range suitable for the sensor to connect.

*: This item will not be displayed when [tEMP] is selected in the setting of the connection sensor.



Item	Display	Content	Setting of connection product
[rAnG] Selection of flow range	[4L]	4 L range	[PFW] is selected
	[16L]	16 L range	
	[40L]	40 L range	
	[100L]	100 L range	
	[250L]	250 L range	
	[10L]	10 L range	[PFA] is selected
	[50L]	50 L range	
	[100L]	100 L range	
	[200L]	200 L range	
	[500L]	500 L range	
	[4L]	4 L range	[PFd] is selected
	[16L]	16 L range	
[40L]	40 L range		

Press the SET button to set. ↓ Move on to the setting of reference condition.

Setting of reference condition

Select the reference condition of flow rate.

*: This setting is available only when [PFA] is selected as the connection product.

This item will not be displayed when another product is selected.

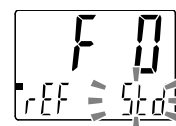

Item	Display	Content
[rEF] Selection of reference condition	[Std]	Standard condition
	[nor]	Reference condition

- Standard condition: In dry air with a temperature of 20 °C and absolute pressure of 101.3 kPa
- Reference condition: In dry air with a temperature of 0 °C and absolute pressure of 101.3 kPa

Press the SET button to set. ↓ Move on to the setting of display unit.



Setting of display unit

Select the unit to display the flow rate (temperature).

*: This item cannot be changed with products that have no unit selection function (fixed to SI unit).



Item	Display	Content	Setting of connection product
[Unit] Selection of display unit	[L]	L/min, L	[PFW] or [Flow] is selected
	[GAL]	gal/min, gal	[PFd] is selected
	[C]	°C (Celsius)	[PFW] or [tEMP] is selected
	[F]	°F (Fahrenheit)	
	[L]	L/min, L	[PFA] is selected
	[Ft]	Cfm, ft ³	

Press the SET button to set. ↓ Move on to the setting of enable/disable IO-Link.

Setting of enable/disable IO-Link

Select to enable or disable IO-Link.

When not using IO-Link, disable this item to prevent moving to IO-Link mode by error due to noise or other unexpected input.

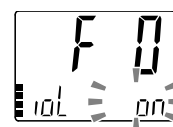

Item	Display	Content
[ioL] Selection of enable/disable IO-Link	[on]	IO-Link enabled
	[oFF]	IO-Link disabled

Press the SET button to set. ↓ Return to function selection mode.

[F 0] Connection product, flow range, display unit, enable/disable IO-Link is completed

[USER] is selected in the setting of [F 0] connection product

Setting of minimum unit of additional range

Set the display/setting minimum unit of the flow rate (temperature).



Item	Display	Content
[Udot] Selection of the minimum unit	[0.001]	0.001 increments
	[0.002]	0.002 increments
	[0.01]	0.01 increments
	[0.02]	0.02 increments
	[0.1]	0.1 increments
	[0.2]	0.2 increments
	[1]	1 increments
	[2]	2 increments

Press the SET button to set.



Move on to the setting of rated lower limit of additional range.

Setting of rated lower limit of additional range

Press the UP or DOWN button to change the value.

Press and hold the button to change the value continuously.
The value can be changed between the digits -1000 and 1000.

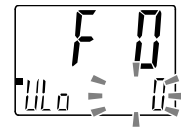

Press the SET button to set.



Move on to the setting of rated upper limit of additional range.

Setting of rated upper limit of additional range

Press the UP or DOWN button to change the value.

Press and hold the button to change the value continuously.
The value can be changed between the digits -1000 and 1000.

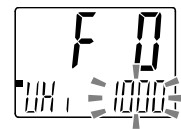

Press the SET button to set.



Move on to the setting of display unit.



Setting of display unit

Select the unit to display the flow rate (temperature).

*: [Ft], [GAL], and [F] cannot be selected with products that have no unit selection function (fixed to SI unit).

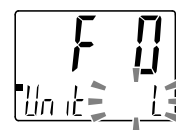

Item	Display	Content
[Unit] Selection of display unit	[L]	L/min, L
	[Ft]	Cfm, ft ³
	[GAL]	gal/min, gal
	[C]	°C (Celsius)
	[F]	°F (Fahrenheit)
	[oFF]	Unit display OFF

Press the SET button to set.



Move on to the setting of accumulated minimum unit.

Setting of accumulated minimum unit

Select the minimum unit to display/set the accumulated flow rate.

*: This item will not be displayed when [C], [F], or [OFF] is selected in the setting of the display unit.



Item	Display	Content
[UAC] Selection of accumulated minimum unit	[0.1]	0.1 increments
	[1]	1 increments
	[10]	10 increments
	[100]	100 increments

Press the SET button to set.



Move on to the setting of accumulated volume per pulse.

Setting of accumulated volume per pulse

Select the accumulated volume to output the accumulated pulse.

*: This item will not be displayed when [C], [F], or [OFF] is selected in the setting of the display unit.

*: The minimum unit/volume per pulse that can be set differs according to the minimum unit of the additional range.



Item	Display	Content
[UPLS] Selection of accumulated volume per pulse	[0.1]	0.1 increments
	[1]	1 increments
	[10]	10 increments
	[100]	100 increments

Press the SET button to set.



Move on to the setting of enable/disable IO-Link.



Setting of enable/disable IO-Link

Select to enable or disable IO-Link.

When not using IO-Link, disable this item to prevent moving to IO-Link mode by error due to noise or other unexpected input.

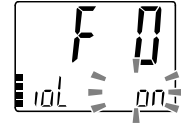

Item	Display	Content
[ioL]	[on]	IO-Link enabled
Selection of enable/disable IO-Link	[oFF]	IO-Link disabled

Press the SET button to set. ↓ Return to function selection mode.

[F 0] Connection product, flow range, display unit, enable/disable IO-Link is completed



Press the SET button for 2 second or longer.

Measurement mode
(Initial setting is completed)



Perform the setting with the 3 step setting mode, simple setting mode and function selection mode.

●Settable range of the additional range

<Minimum settable unit [Udot]: "0.001", "0.01", "0.1", "1">

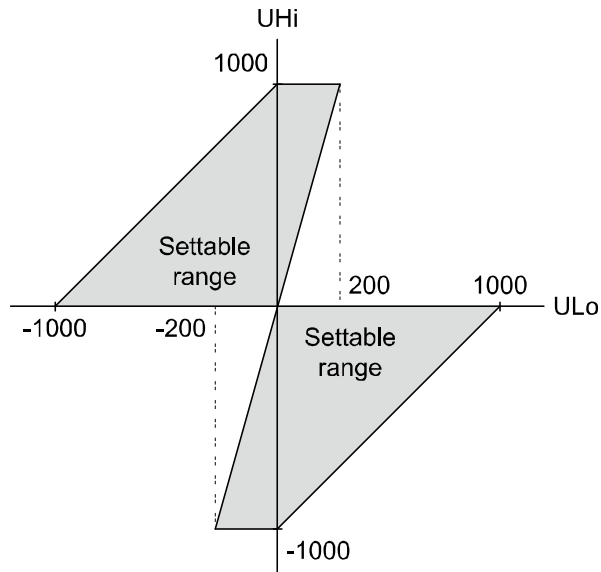

<Minimum settable unit [Udot]: "0.002", "0.02", "0.2", "2">

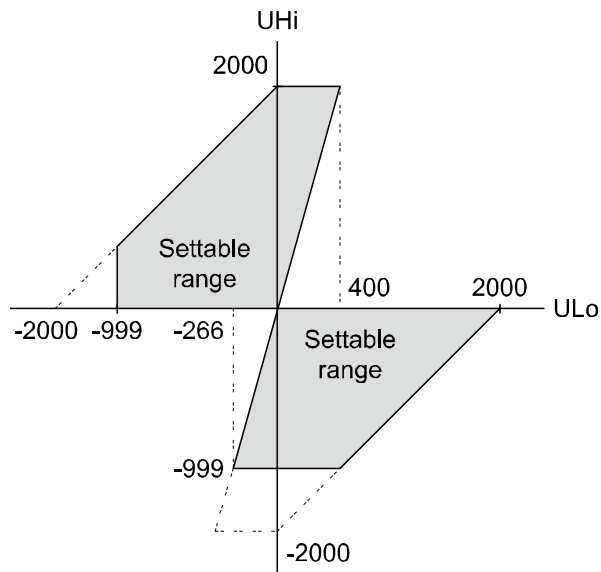

*: When flow range, minimum unit/lower limit/upper limit of additional range is changed, setting below will be initialized and cleared.

These items must be set again.

- Display unit settings
- Flow setting
- Hysteresis setting
- Peak/Bottom value

3 Step Setting Mode

3 step setting mode

In this mode, the set values can be input in just 3 steps.

Use this mode if the product is to be used straight away, after changing only the set values.

(The current flow value is displayed on the main display.)

<Operation>

[3 step setting mode (hysteresis mode)]

In the 3 step setting mode, the set value (P_1 or n_1, P_2 or n_2) and hysteresis (H_1, H_2) can be changed.

After selecting the channel, set the items on the sub display (set value or hysteresis) with the DOWN button.

When changing the set value, follow the operation below. The hysteresis setting can be changed in the same way.

- (1) Press the SET button once when the item to be changed is displayed on the sub display.
The set value on the sub display (right) will start flashing.

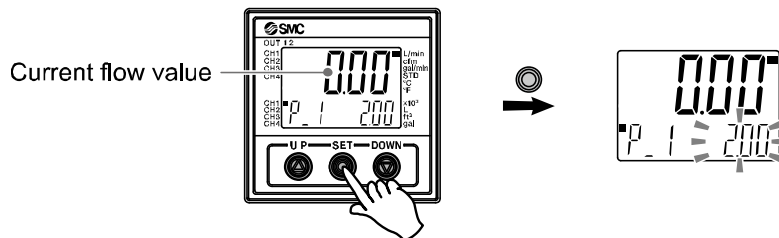

- (2) Press the UP or DOWN button to change the set value.
The set value can be increased with UP button and can be reduced with DOWN button.

• Press the UP button once to increase the value by one digit, press and hold to continuously increase.

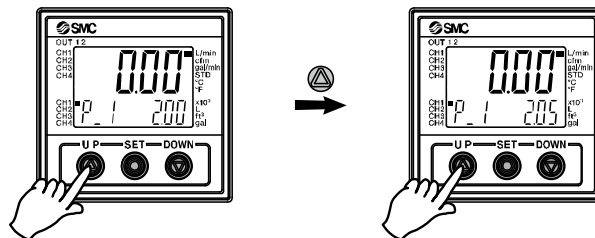

• Press the DOWN button once to reduce the value by one digit, press and hold to continuously reduce.

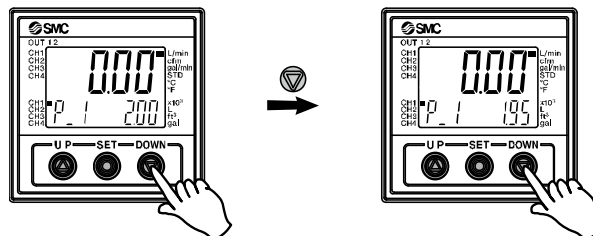

• When the UP and DOWN buttons are pressed and held simultaneously for 1 second or longer, the set value is displayed as [- -], and the set value will be the same as the current flow value automatically (snap shot function (Refer to page 67)). Afterwards, it is possible to adjust the value by pressing the UP or DOWN button.

- (3) Press the SET button to complete the setting.

The product turns on within a set flow range (OUT1: from P1L to P1H, OUT2: from P2L to P2H) during window comparator mode. Set P1L/P2L, the lower limit of the switch operation, and P1H/P2H, the upper limit of the switch operation and WH1/WH2 (hysteresis) following the instructions given on page 30. (When reversed output is selected, the sub display (left) shows [n1L]/[n2L] and [n1H]/[n2H].) Please refer to the "List of output modes" on page 39 for the relationship between the set values and operation.

*: Setting of the normal/reverse output switching and hysteresis/window comparator mode switching are performed with the function selection mode [F 1] Setting of OUT1, [F 2] Setting of OUT2.

Simple Setting Mode

<Operation>

[Simple setting mode (hysteresis mode)]

In the simple setting mode, the set value, hysteresis and delay time can be changed while checking the current flow value (main display).

- (1) After selecting the channel, press the SET button for 1 second or longer, but less than 3 seconds, in measurement mode. [SEt] is displayed on the main display.

When the button is released while in the [SEt] display, the current flow value is displayed on the main display, [P_1] or [n_1] is displayed on the sub display (left), and the set value is displayed on the sub display (right) (Flashing).

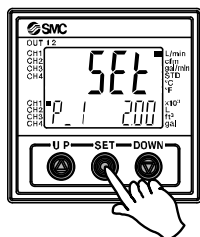

- (2) Change the set value with UP or DOWN button, and press the SET button to set the value. Then, the setting moves to hysteresis setting. (The snap shot function can be used. (Refer to page 67))

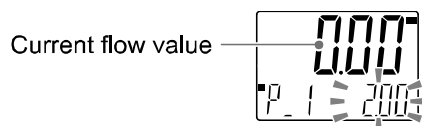

- (3) Change the set value with UP or DOWN button, and press the SET button to set the value. Then, the setting moves to setting of OUT2. (The snap shot function can be used. (Refer to page 67))



- (4) Complete the OUT1 setting.

[P_2] or [n_2] is displayed on the sub screen (left). Continue with setting the OUT2.

Press and hold the SET button for 2 seconds or longer to complete the setting. The product will return to measurement mode.

*1: Selected items (1) to (4) become valid after pressing the SET button.

*2: After enabling the setting by pressing the SET button, it is possible to return to measurement mode by pressing the SET button for 2 seconds or longer.

*3: When the output mode (refer to page 35) is set to error output or switch output OFF, the simple setting mode cannot be used.

In the window comparator mode, set P1L/P2L, the lower limit of the switch operation, and P1H/P2H, the upper limit of the switch operation, WH1/WH2 (hysteresis) and dt1/dt2 (delay time) following the instructions given on page 32.

(When reversed output is selected, the sub display (left) shows [n1L]/[n2L] and [n1H]/[n2H].)

Set each P1/P2 (set value), referring to the Accumulated output mode on page 32.

(When reversed output is selected, the main screen displays n1/n2)

Please refer to the "List of output modes" on page 39 for the relationship between the set values and operation.

Function Selection Mode

■ Function selection mode

After selecting the channel, in measurement mode, press the S button for 3 seconds or longer (but less than 5 seconds), to display [F 0].

Select to display the function to be changed [F□□]. Press and hold the SET button for 2 seconds or longer in function selection mode to return to measurement mode.

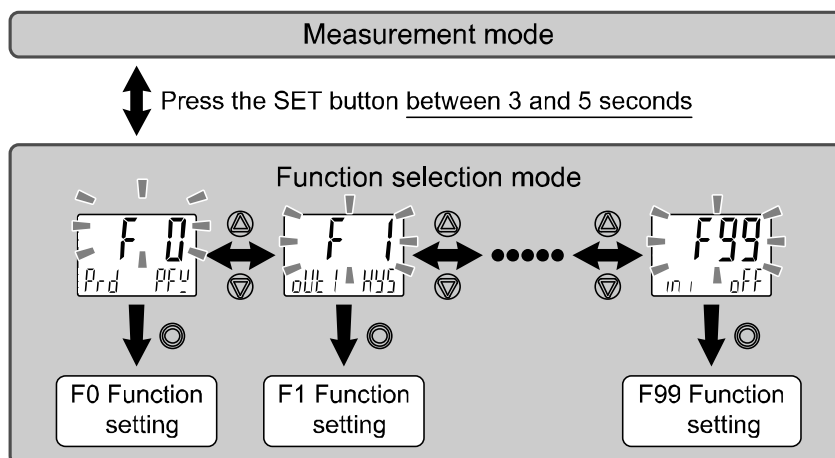

*: Some products do not have all the functions. If no function is available or selected due to configuration of other functions, [- -] is displayed on the sub display (right).

*: All channel indicators turn on for the setting which is common for all channels.

■ Default setting

The default setting is as follows.

If no problem is caused by this setting, keep these settings.

To change a setting, enter function selection mode.

● [F 0] Connection product, flow range, display unit, enable/disable IO-Link ➡ Page 23

Item	Default setting
Connected product	PFW
Connected sensor	Flow
Connected sensor range	4 L range
Display units	L/min, L
Enable/disable IO-Link	IO-Link enabled

● [F 1] Setting of OUT1 ➡ Page 35

Item	Explanation	Default setting
Output mode	Either hysteresis mode, window comparator mode, accumulated output, accumulated pulse, error output or switch output off can be selected.	Hysteresis mode
Reversed output	Selects which type of switch output is used, normal or reversed.	Normal output
Flow setting	Sets the ON and OFF point of the switch output.	2.00 L/min
Hysteresis	Appropriate setting of the hysteresis will prevent the switch output from chattering.	0.20 L/min
Delay time	Delay time of the switch output can be selected.	0.00 sec.
Display colour	Select the display colour.	Output ON : Green Output OFF: Red (Linked to OUT1)

● [F 2] Setting of OUT2 ➡ Page 40

Item	Explanation	Default setting
Output mode	Either hysteresis mode, window comparator mode, accumulated output, accumulated pulse, error output or switch output off can be selected.	Hysteresis mode
Reversed output	Selects which type of switch output is used, normal or reversed.	Normal output
Flow setting	Sets the ON and OFF point of the switch output.	2.00 L/min
Hysteresis	Appropriate setting of the hysteresis will prevent the switch output from chattering.	0.20 L/min
Delay time	Delay time of the switch output can be selected.	0.00 sec.
Display colour	Select the display colour.	Output ON : Green Output OFF: Red (Linked to OUT1)

● Other parameter settings

Item	Page	Default setting
[F 3] Digital filter setting	Page 43	0.00 sec.
[F10] Sub display setting	Page 44	dEF (Standard)
[F14] Zero cut-off setting	Page 49	Not available (PFW is selected)
[F20] External input setting	Page 50	Accumulated value reset
[F30] Accumulated flow value hold setting	Page 51	OFF
[F80] Power saving mode	Page 52	OFF
[F81] Security code	Page 53	OFF
[F90] Setting of all functions	Page 55	OFF
[F95] Channel to channel copy function setting	Page 57	OFF
[F96] Sensor input display	Page 58	No configurable items
[F98] Output check	Page 59	N/A (normal output)
[F99] Reset to default settings	Page 66	OFF

■[F 1] Setting of OUT1

Set the output mode of OUT1.

Output turns on when the flow is greater than the set value.

Output ON lights in green and output OFF lights in red as default setting.

Please refer to the "List of output modes" on page 39 for the relationship between the set items and operation.

<Operation>

Press the UP or DOWN button in function selection mode to display [F 1].

Press the SET button. ↓ Move on to the output mode setting.

Output mode setting

Press the UP or DOWN button to select the required output mode.

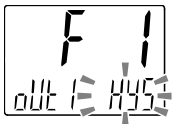

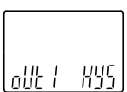

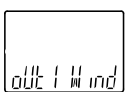
Hysteresis

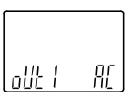
Window
comparator

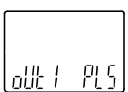
Accumulated
output

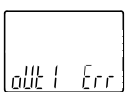
Pulse output

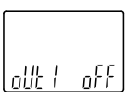

Error output



Switch output
OFF

Press the SET button to set. ↓ Move on to the reversed output setting.

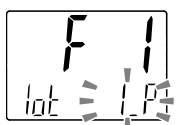
Reversed output setting

Press the UP or DOWN button to select the reversed output.

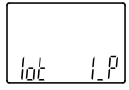

Normal
output

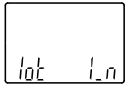

Reversed
output

[OFF] Switch output OFF is selected. Press the SET button to move on to the display colour setting.

Press the SET button to set. ↓ Move on to the flow (temp.) setting.

Flow (temp.) setting

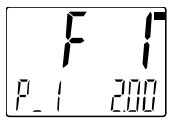
Set the flow (temp.) based on the setting method on page 30.



Hysteresis mode: [P_1]
 Window comparator mode: [P1L] [P1H]
 "P" is changed to "n" as [P_1] → [n_1] when reversed output is selected.
 The snap shot function can be used.
 (Refer to page 67)

[Err] Error output
[PLS] Pulse output is selected. Press the SET button to move on to the display colour setting.

[AC] Accumulated output is selected. Press the SET button to move on to the accumulated output setting.

Press the SET button to set. ↓ Move on to the hysteresis setting.

Refer to page 37

Hysteresis setting

Set the hysteresis referring to the setting method on page 30.

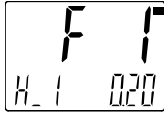

Hysteresis mode: [H_1]
Window comparator mode: [WH1]
The snap shot function can be used.
(Refer to page 67)

Press the SET button to set. Move on to the delay time setting.

Delay time setting

Set the delay time referring to the setting method on page 32.

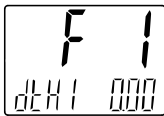

Delay time setting at ON



Delay time setting at OFF

Press the SET button to set. Move on to the display colour setting.

Display colour setting

Press the UP or DOWN button to select the display colour.

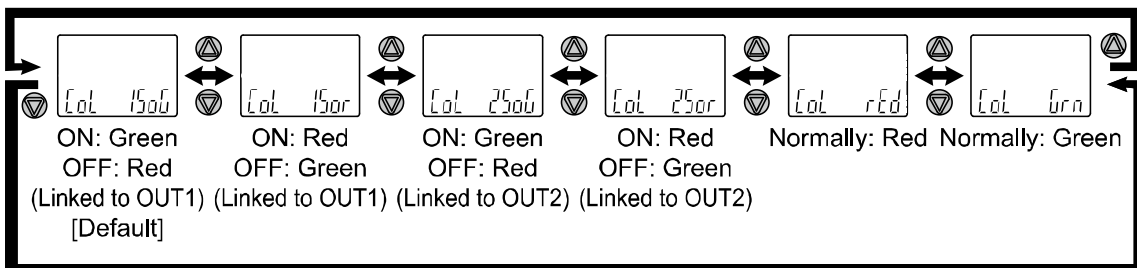
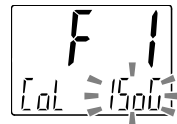

Press the SET button to set. Return to function selection mode.

[F 1] Setting of OUT1 is completed

*1: Selected item becomes valid after pressing the SET button.

*2: After enabling the setting by pressing the SET button, it is possible to return to the measurement mode by keeping pressing the SET button for 2 seconds or longer.

([AC] Accumulated output is selected)

Accumulated output setting

Press the UP or DOWN button to select accumulated output.

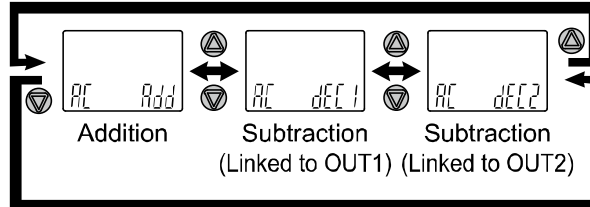

Press the SET button to set. ↓ Move on to the accumulated value setting.

Accumulated value setting

Perform the accumulated value setting. (Refer to page 38)

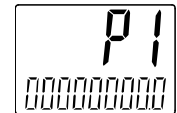

Press the SET button to set. ↓ Move on to the display colour setting.

Display colour setting

Press the UP or DOWN button to select the display colour.

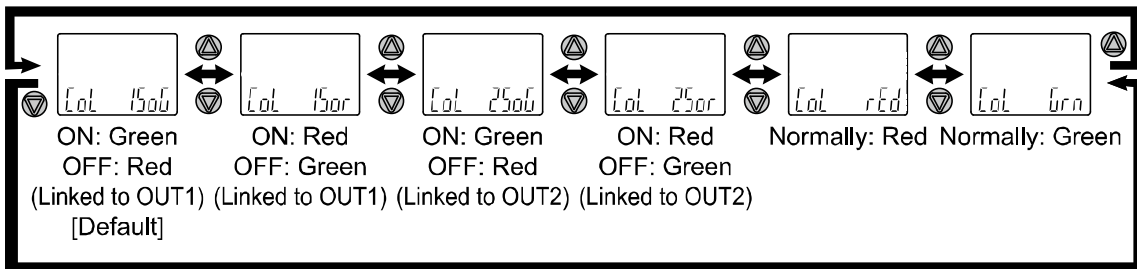
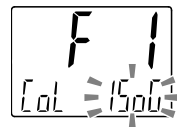

Press the SET button to set. ↓ Return to function selection mode.

[F 1] Setting of OUT1 is completed

*1: Selected item becomes valid after pressing the SET button.

*2: After enabling the setting by pressing the SET button, it is possible to return to the measurement mode by keeping pressing the SET button for 2 seconds or longer.

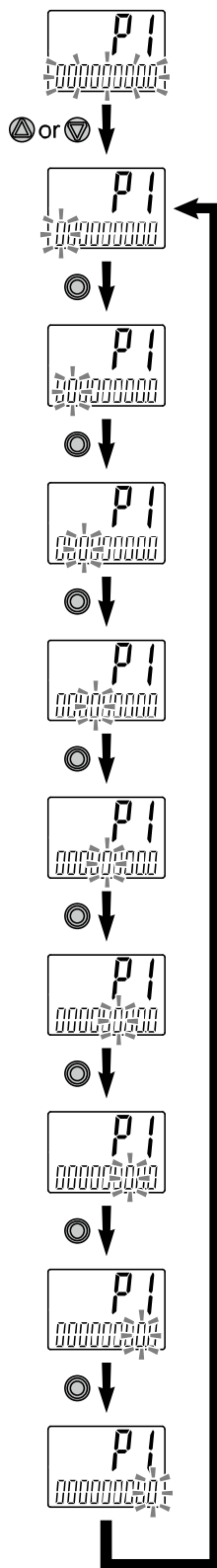

The sub screen displays the value, and the leftmost digit of the set value will start flashing.
 (The required accumulated value should be input one digit at a time).

Press the UP or DOWN buttons to change the value.

Press the SET button to move on to the input of the next right digit.

Pressing the SET button again will select the next digit to the right.

After the input of the 9 digits is complete, press the SET button for 1 second or longer to confirm.

When the SET button is pressed for 1 second or longer, [00000000] will start flashing.

•List of output modes

Select the operation required from the table below. Characters in () are for OUT2.

	Normal output	Reversed output
Hysteresis mode		
Window comparator mode		
Accumulated output mode (Increment)		
Accumulated output mode (Decrement)		
Accumulated pulse output mode		
Error output mode		
OFF mode		

*: Applicable errors are Er0, 1, 2, 4, 6 to 8, 14, and 40.

If the point at which the switch output changes is outside of the set flow range due to the selection of normal or reversed output, the hysteresis value will be automatically adjusted.

■[F 2] Setting of OUT2

Set the output mode of OUT2.

Output turns on when the flow is greater than the set value.

Please refer to the "List of output modes" on page 39 for the relationship between the set items and operation.

<Operation>

Press the UP or DOWN button in function selection mode to display [F 2].

Press the SET button. ↓ Move on to the output mode setting.

Output mode setting

Press the UP or DOWN button to select the required output mode.



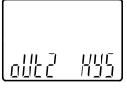

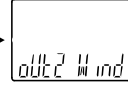
Hysteresis

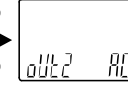
Window
comparator

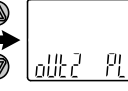
Accumulated
output

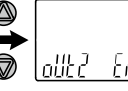
Pulse output

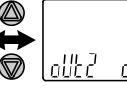

Error output



Switch output
OFF

Press the SET button to set. ↓ Move on to the reversed output setting.

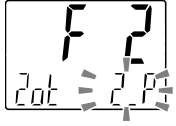
Reversed output setting

Press the UP or DOWN button to select the reversed output.

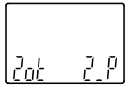

Normal
output



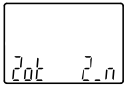

Reversed
output

[OFF] Switch output OFF is selected. Press the SET button to move on to the display colour setting.

Press the SET button to set. ↓ Move on to the flow (temp.) setting.

Flow (temp.) setting

Set the flow (temp.) based on the setting method on page 30.



Hysteresis mode: [P_1]
 Window comparator mode: [P1L] [P1H]
 "P" is changed to "n" as [P_1] → [n_1] when reversed output is selected.
 The snap shot function can be used.
 (Refer to page 67)

[Err] Error output
[PLS] Pulse output is selected. Press the SET button to move on to the display colour setting.

[AC] Accumulated output is selected. Press the SET button to move on to the accumulated output setting.

Press the SET button to set. ↓ Move on to the hysteresis setting.

Refer to page

Hysteresis setting

Set the hysteresis referring to the setting method on page 30.



Hysteresis mode: [H_1]
Window comparator mode: [WH1]
The snap shot function can be used.
(Refer to page 67)

Press the SET button to set. Move on to the delay time setting.

Delay time setting

Set the delay time referring to the setting method on page 32.



Delay time setting at ON



Delay time setting at OFF

Press the SET button to set. Move on to the display colour setting.

Display colour setting (common setting for [F 1])

Press the UP or DOWN button to select the display colour.

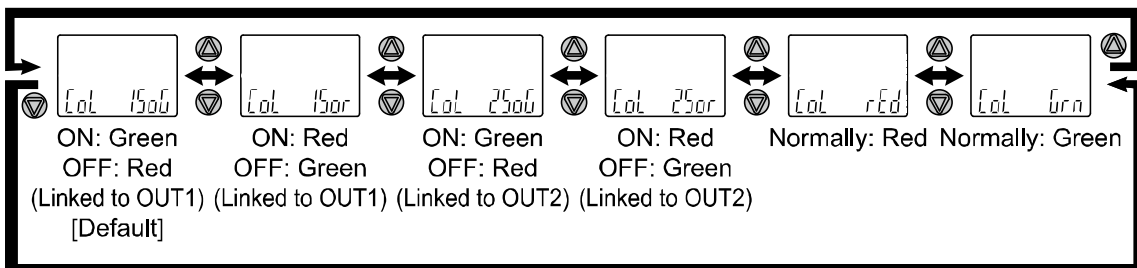

Press the SET button to set. Return to function selection mode.

[F 2] Setting of OUT2 is completed

*1: Selected item becomes valid after pressing the SET button.

*2: After enabling the setting by pressing the SET button, it is possible to return to the measurement mode by keeping pressing the SET button for 2 seconds or longer.

([AC] Accumulated output is selected)

Accumulated output setting

Press the UP or DOWN button to select accumulated output.

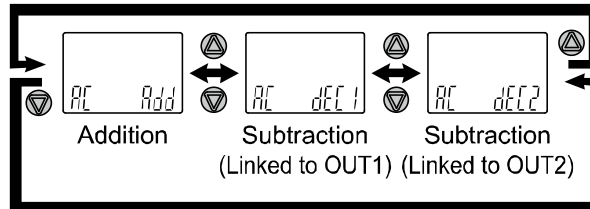
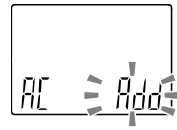

Press the SET button to set. ↓ Move on to the accumulated value setting.

Accumulated value setting

Perform the accumulated value setting. (Refer to page 38)

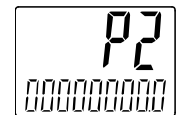

Press the SET button to set. ↓ Move on to the display colour setting.

Display colour setting

Press the UP or DOWN button to select the display colour.

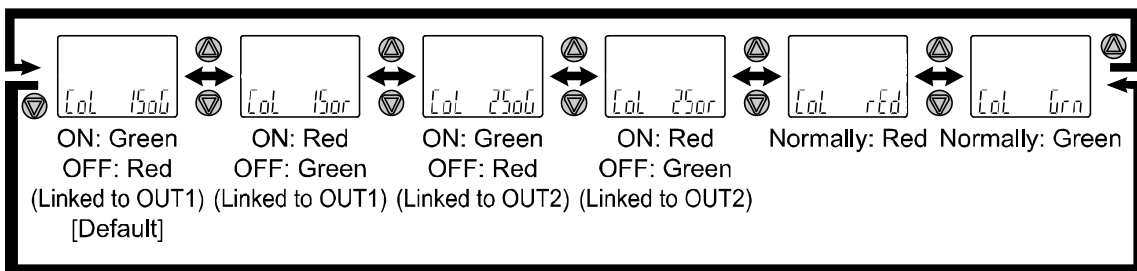

Press the SET button to set. ↓ Return to function selection mode.

[F 2] Setting of OUT2 is completed

*1: Selected item becomes valid after pressing the SET button.

*2: After enabling the setting by pressing the SET button, it is possible to return to the measurement mode by keeping pressing the SET button for 2 seconds or longer.

■[F 3] Digital filter setting

The Digital filter can be selected to filter the flow measurement.

Output chattering or flicker in the measurement mode display can be reduced by setting the digital filter.

<Operation>

Press the UP or DOWN button in function selection mode to display [F 3].

Press the SET button. ↓ Move on to the digital filter setting.

Digital filter setting

Press the UP or DOWN button to select the digital filter.

The digital filter can be set in the range 0.00 to 30.0 [sec.] in increments of 0.01 [sec.].

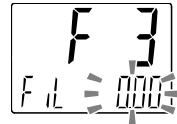

Press the SET button to set. ↓ Return to function selection mode.

[F 3] Digital filter setting is completed

*1: Each set value is a guideline for 90% response time.

*2: Both the switch output and flow display are affected. When only switch output needs to be affected, select the delay time setting. (page 36 and 41)

■ [F10] Sub display setting

Change the display style of the sub display.
Detailed contents are shown in the pages from 45.

<Operation>

Press the UP or DOWN button in function selection mode to display [F10].

Press the SET button. ↓ Move on to the sub display setting.

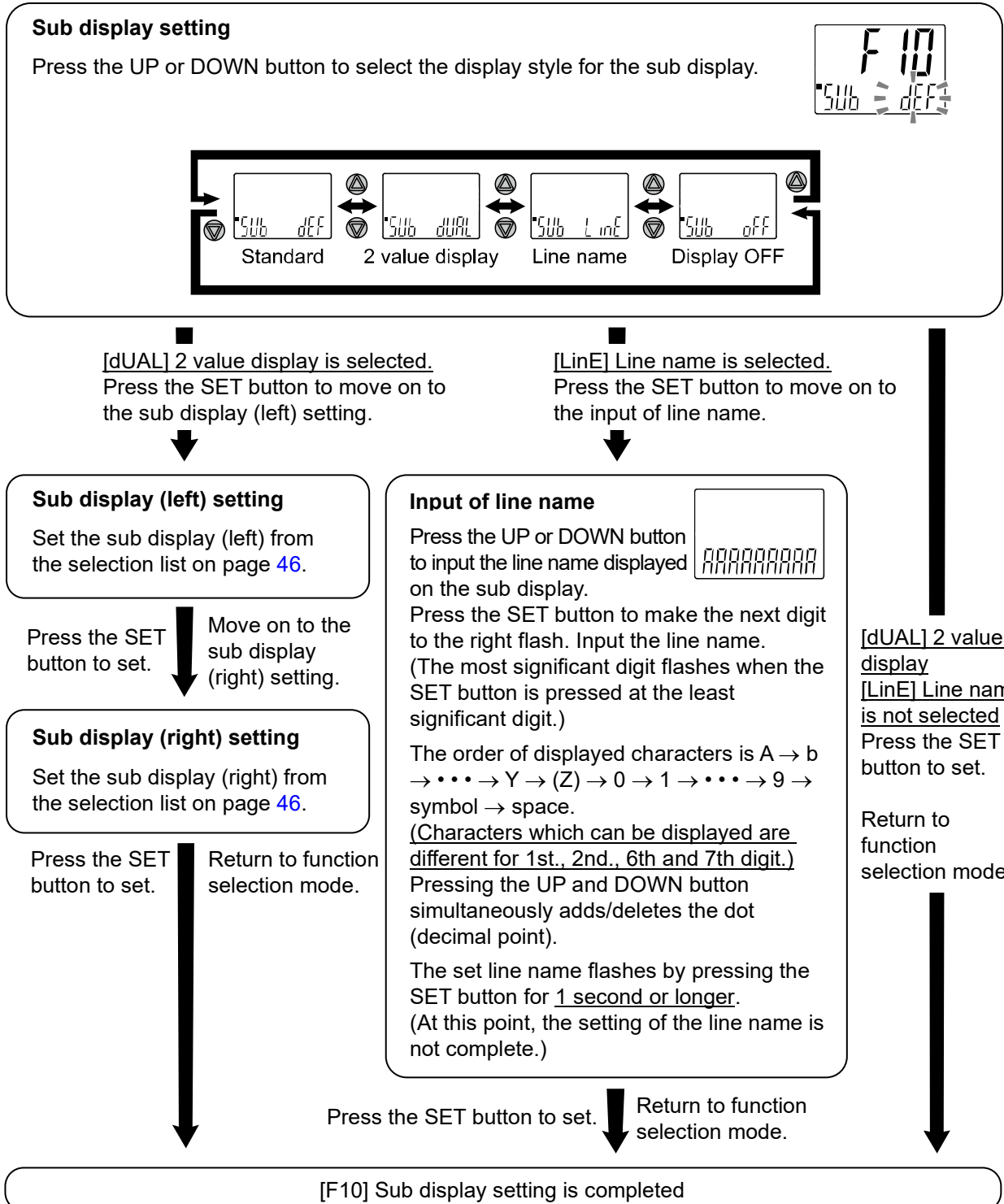

<Sub display>

•Standard

The Standard display function displays the items and values on the sub display.

The displayed item varies depending on the setting of the output mode. Select the displayed items by pressing the DOWN button in measurement mode.

(Hysteresis mode, error output, Accumulated output, Accumulated pulse output, switch output off)

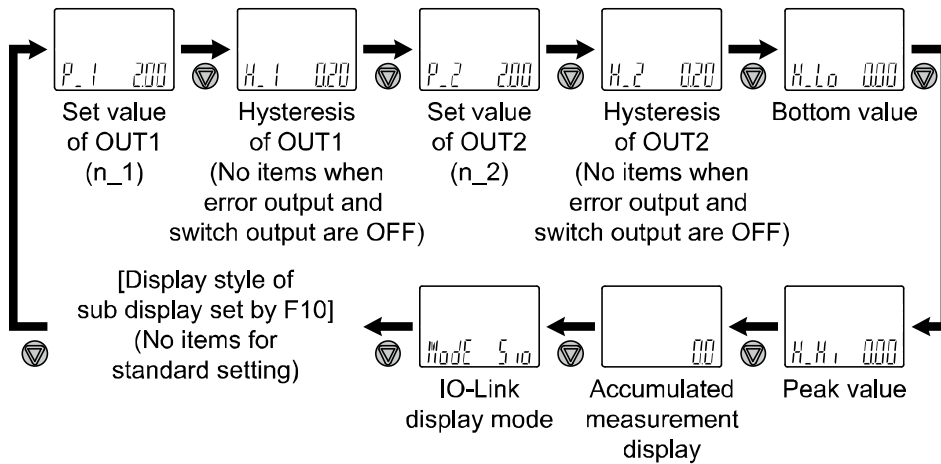

(Window comparator mode)

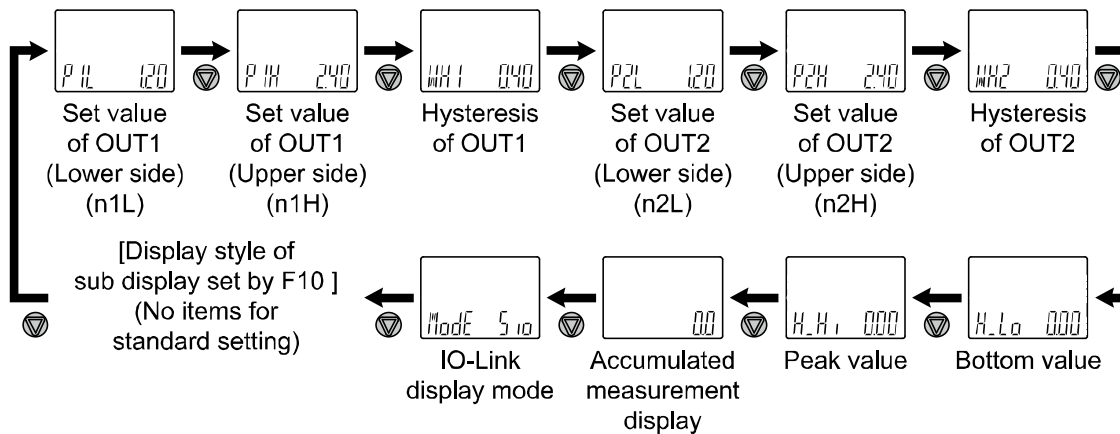







•2 value display

The 2 value display function displays the items listed below on the right and left side of the sub display.

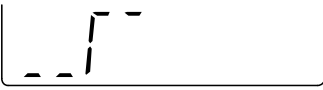
List of items for selection

Item	Details	Sub display		Remarks
		Left side	Right side	
P ₁ (n ₁)	Set value for OUT1 hysteresis mode	○	○	When hysteresis mode is selected
H ₁	OUT1 hysteresis mode	○	○	When hysteresis mode is selected
P _{1L} (n _{1L})	OUT1 Window comparator mode set value (Lower side)	○	○	When window comparator mode is selected
P _{1H} (n _{1H})	OUT1 Window comparator mode set value (Upper side)	○	○	When window comparator mode is selected
WH ₁	OUT1 window comparator mode	○	○	When window comparator mode is selected
P ₂ (n ₂)	Set value for OUT2 hysteresis mode	○	○	When hysteresis mode is selected
H ₂	OUT2 hysteresis mode	○	○	When hysteresis mode is selected
P _{2L} (n _{2L})	OUT2 Window comparator mode set value (Lower side)	○	○	When window comparator mode is selected
P _{2H} (n _{2H})	OUT2 Window comparator mode set value (Upper side)	○	○	When window comparator mode is selected
WH ₂	OUT1 window comparator mode	○	○	When window comparator mode is selected
H _{H1}	Flow peak value	○	×	
H _{Lo}	Flow bottom value	×	○	
Unit	Flow display unit	○	○	
rAnG	Rated flow range	○	○	
Mod ₁	OUT1 output mode/output style	○	×	
Mod ₂	OUT2 output mode/output style	×	○	
L _{inE}	String of random characters	○	×	Line name 4 left digits
L _{inE}	String of random characters	×	○	Line name 5 right digits
CH	Channel display	○	○	
M _{u1}	Measured value of CH1	○	○	
M _{u2}	Measured value of CH2	○	○	
M _{u3}	Measured value of CH3	○	○	
M _{u4}	Measured value of CH4	○	○	
off	Display OFF	○	○	

Table showing the output mode and output form when Md1 and Md2 are selected.

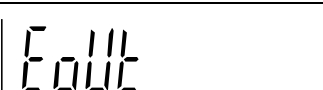
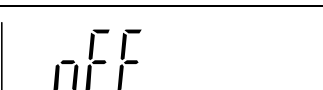
Output mode	Output style	Display style
Hysteresis mode	Normal output	
	Reversed output	
Window comparator mode	Normal output	
	Reversed output	
Accumulated output mode	Normal/Reversed output	
Accumulated pulse output mode	Normal/Reversed output	
Error output	Normal/Reversed output	
Switch output off	-	

When using the 2 value display function, 3 step setting is not available for the display.
 (When setting 3 step, select each set value to be displayed by pressing the DOWN button.)

When output operation mode is changed after selecting the 2 value display, the selected display items will not be applicable and [- -] will be displayed. In this case, select items for the 2 value display setting again.

•Character string display

•Function to display the specified character string on the sub-screen.

When line name is input, characters which can be displayed for each digit are as follows.

(Display pattern for 3rd, 4th, 5th, 8th and 9th digit from the left)

Characters Q, X, Z, /, or * cannot be displayed.

A	B	C	D	E	F	G	H	I	J	K	L	M	N	O	P	R	S	T	U	V	W	Y
A	b	c	d	e	f	G	H	I	J	K	L	M	N	O	P	r	S	T	U	V	W	Y

0	1	2	3	4	5	6	7	8	9	Symbol	Speace
0	1	2	3	4	5	6	7	8	9	_	-

(Display patter for 1st., 2nd., 6th., and 7th digit)

Characters A to Z can be displayed (the same as the 3 digits on the right).

A	B	C	D	E	F	G	H	I	J	K	L	M	N	O	P	Q	R	S	T	U	V	W	X	Y	Z
A	b	c	d	e	f	G	H	I	J	K	L	M	N	O	P	Q	r	S	T	U	V	W	X	Y	Z

<Pattern for 3 digits
on the right>

0	1	2	3	4	5	6	7	8	9	Symbol	K	M	N	R	V	W	Speace			
0	1	2	3	4	5	6	7	8	9	_	-	/	#	P	n	M	R	V	W	-

•Display OFF

The Sub display is not displayed.

■[F14] Zero cut-off setting

When the flow display value is close to zero, the product rounds the value and zero will be displayed. The zero cut-off range is 0.0 to 10.0% F.S., and can be set in 1.0% F.S. increments.

*: It can be set only when [PFA] is selected as the connection product.

[---] is shown in other settings and the setting is not available.

<Operation>

Press the UP or DOWN button in function selection mode to display [F14].

Press the SET button. ↓ Move on to the select zero cut-off setting.

Select zero cut-off setting

Press the UP or DOWN button to select the value of zero cut-off.

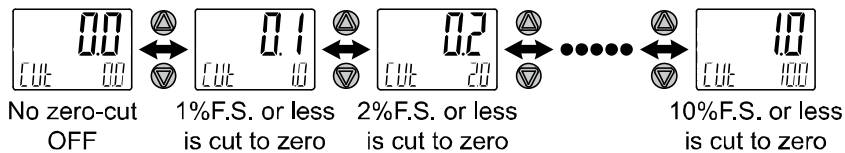

*: The display above is an example when 10 L range and unit selection function are [L/min] selected.

*: When the actual flow is smaller than the displayed value in the upper line, zero will be displayed.

Example: 10 L range

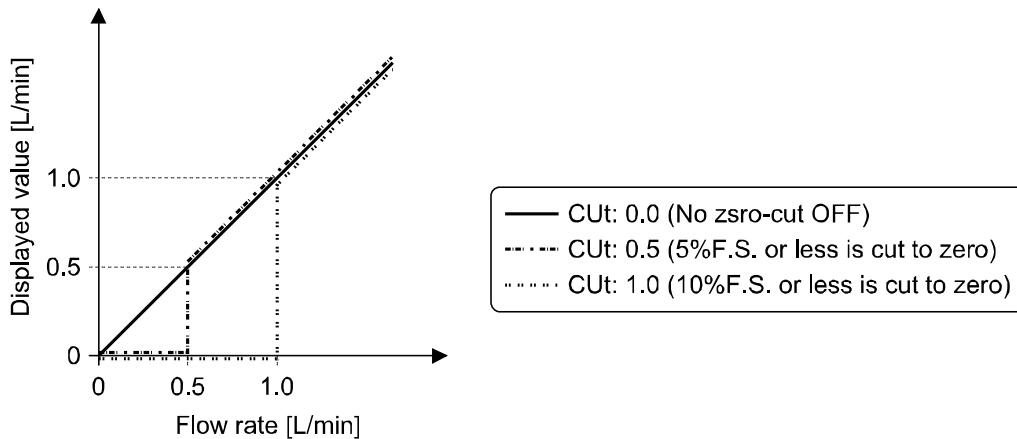

Press the SET button to set. ↓ Return to function selection mode.

[F14] Zero cut-off setting is completed

■[F20] External input setting

This function is available when the model includes the external input function. The accumulated flow, peak value and bottom value can be reset remotely.

*: When using a model without external input function, this setting is not available and [---] will be displayed.

•**Accumulated flow external reset:** A function to reset the accumulated flow value when an external input signal is applied.

In accumulated increment mode, the accumulated flow value will reset to zero, and then increase from zero.

In accumulated decrement mode, the accumulated flow value will reset to a set value, and then decrease from the set value.

*: Each time the accumulated flow external reset is activated and when the accumulated flow value is stored, a memory device (EEPROM) is accessed. The memory device has a limit of 1 million cycles. When using the product, it should be considered that the total number of external input resets and accumulated values stored must not exceed 1 million.

•**Peak/Bottom value reset:** A function to clear the peak value or bottom value when an external input signal is applied.

•**OFF:** The external input function will not operate.

<Operation>

Press the UP or DOWN button in function selection mode to display [F 20].

Press the SET button. ↓ Move on to the external input setting.

External input setting

Press the UP or DOWN button to select the external input equipment.



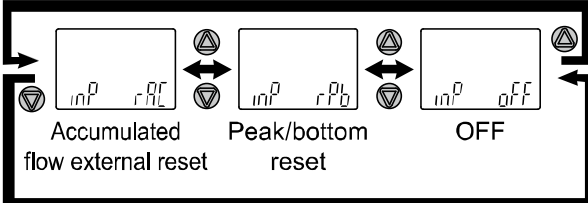

Press the SET button to set. ↓ Move on to the setting of enable/disable external input signal.

Setting of enable/disable external input signal

Press the UP or DOWN button to select the enable/disable the external input signal.



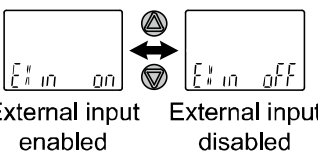

Press the SET button to set. ↓ Return to function selection mode.

[F20] External input setting is completed

Input signal: Connect the external input to GND for NPN type. Connect to Vcc for PNP type. 30 msec. or longer.

- When the input signal is ON, the screen will display [000] for 1 second.
- After turning OFF the input signal, flow accumulation resumes (displays peak value and bottom value) within 30 msec.
- To input successive signals, the [000] display must clear before the next signal is input.

■[F30] Accumulated flow value hold setting

Select the setting in which the accumulated flow measurement value is stored to the internal memory. The default setting is not to store the accumulated flow when the power supply is turned off.

This function enables the accumulated flow value to be stored in permanent memory every 5 minutes.

The internal memory life varies depending on the number of times that the memory device can be accessed, so this must be taken into account before use.

If the product is operated 24 hours per day, the maximum writable limit will be as follows:

Data memorized every 5 minutes --- 5 minutes x the number of times the memory device can be accessed (0.975 million cycles) = 4.87 million minutes = Approx. 9.3 years

<Operation>

Press the UP or DOWN button in function selection mode to display [F 30].

Press the SET button. ↓ Move on to the accumulated flow value hold setting.

Accumulated flow value hold setting

Press the UP or DOWN button to select the accumulated flow value hold setting.

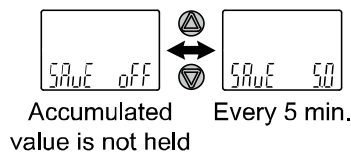

Press the SET button to set. ↓ Return to function selection mode.

[F30] Accumulated flow value hold setting is completed

*: Data memorization is performed every 5 minutes, this means that the accumulated flow value for up to 2 or 5 minutes before the power supply is turned off will not be added to the device memory.

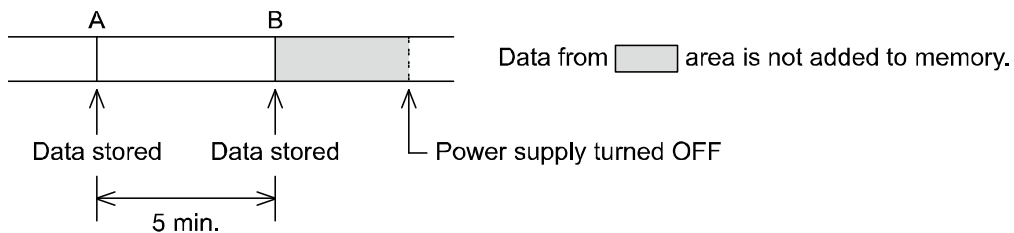

When the power supply is turned on again, the accumulated flow count will start from the value recorded at B.

■[F80] Power saving mode

Power saving mode can be selected.

When selected and no buttons are pressed for 30 seconds, the product will shift to power saving mode.

<Operation>

Press the UP or DOWN button in function selection mode to display [F80].

Press the SET button. ↓ Move on to the power saving mode.

Power saving mode (Setting common for all channels)

Press the UP or DOWN button to select the power saving mode.

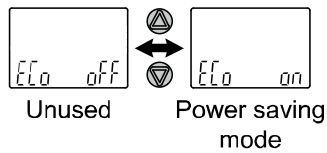

Press the SET button to set. ↓ Return to function selection mode.

[F80] Power saving mode is completed

In power saving mode, when buttons are pressed the display is normal, but if no buttons are pressed for 30 seconds, it will revert to power saving mode. (Power saving is only enabled in measurement mode)

During power saving mode, [ELo] will flash in the sub display and the operation light is ON (only when the switch is ON).

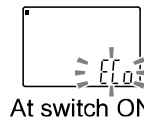

At switch ON

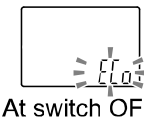

At switch OFF

■[F81] Security code

The security code can be turned on or off and the security code can be changed when unlocked.

<Operation>

Press the UP or DOWN button in function selection mode to display [F81].

Press the SET button. ↓ Move on to the security code.

Security code (Setting common for all channels)

Press the UP or DOWN button to select the setting of security code.

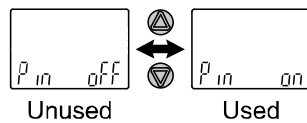

Press the SET button to set. ↓ Move on to the security code checking.

[oFF] (not use) is selected.

Press the SET button to return to function selection mode.

Security code checking

Press the UP or DOWN button to input the security code on the sub display (right).
(The default setting is [000].)*

For instructions on how to enter the security code, refer to "How to input and change the security code" on page 70.

If the security code entered is incorrect, [FAL] will be displayed, and the security code must be entered again.

If the wrong security code is entered 3 times, [nG] is displayed and the device returns to function selection mode.



Press the SET button for 1 second to set. ↓ Move on to the security code changing.

Security code changing

Press the UP or DOWN button to input the changed security code on the main display. *
For instructions on how to enter the security code, refer to "How to input and change the security code" on page 70.



After entry, the changed security code will flash by pressing the SET button for 1 second.
(At this point, the changing of the security code is not completed)
Return to the change of setting again by pressing the UP or DOWN button.



Press the SET button for 1 second to set. ↓ Return to function selection mode.

[F81] Security code is completed

If the security code function is enabled, it is will be necessary to input a security code to release the key-lock.

*: If a key is not pressed for 30 seconds while entering the security code, function selection mode will return.

● **Special function setting**

■ **[F90] Setting of all functions**

All functions can be set in turn.

<Operation>

Press the UP or DOWN button in function selection mode to display [F90].

Press the SET button. ↓ Move on to the setting of all functions.

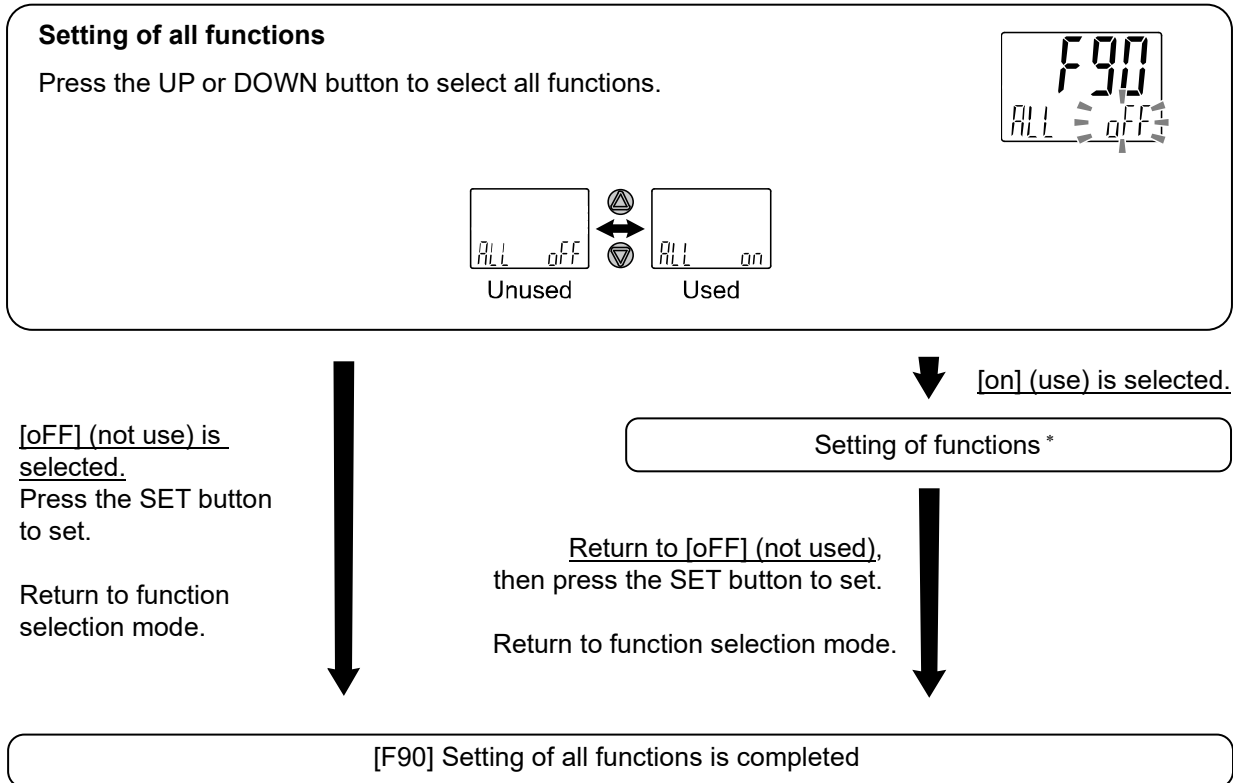

*: Setting of each function

Every time the SET button is pressed, the display moves to the next function in order of "Setting of each function" on page 56. Set by using the UP and DOWN buttons.

For details of how to set each function, refer to the relevant setting of function section in this manual.

*: Measurement mode can be returned from any setting items by pressing and holding the SET button for 2 seconds or longer.

*: The function setting from before returning to the measurement mode is maintained.

● Setting of each function

Order	Function
1	Setting of connection product
2	Setting of connection sensor
3	Setting of flow range (PFW is selected)
4	Setting of display unit
5	Setting of unit specification
6	Setting of enable/disable IO-Link
7	Output mode setting of OUT1
8	Reversed output setting of OUT1
9	Flow setting of OUT1
10	Hysteresis setting of OUT1
11	Delay time setting of OUT1
12	Display colour setting
13	Output mode setting of OUT2
14	Reversed output setting of OUT2
15	Flow setting of OUT2
16	Hysteresis setting of OUT2
17	Delay time setting of OUT2
18	Display colour setting
19	Digital filter setting
20	Sub display setting
21	Zero cut-off setting (PFA is selected)
22	External input setting
23	Setting of enable/disable external input signal
24	Accumulated flow value hold setting
25	Power saving mode
26	Security code

*: Measurement mode can return from any setting item by pressing the SET button for 2 seconds or longer.

*: Function set before returning to the measurement mode is maintained.

■[F95] Channel to channel copy function setting

Set channel to channel copy function.

<Operation>

Press the UP or DOWN button in function selection mode to display [F95].

Press the SET button. ↓ Move on to the channel to channel copy function setting.

Channel to channel copy function setting

Set values between [F 0] and [F80] are copied to the other channel.

Press the UP or DOWN button to select the channel to channel copy function.

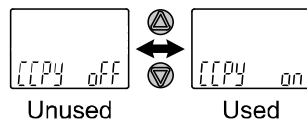

■
[off] (not use) is selected.

Press the SET button to return to function selection mode.

↓ [on] (use) is selected.
Press the SET button to set.

Select the channel to be copied

Press UP or DOWN button to select the channel to be copied in the sub screen (on the right).

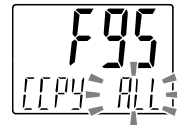

*: Channel from which a copy is made of the currently selected channel.

Displayed in the the sub screen (on the left).

*: When changing the channel to be copied, change the channel in measurement mode and the select function again.

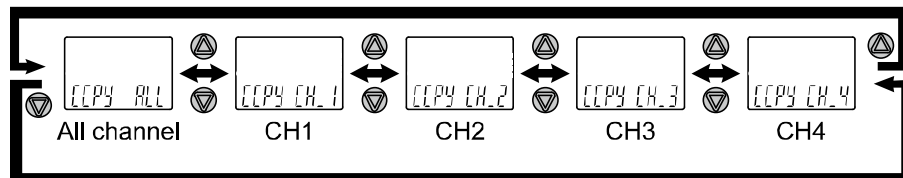

Press the SET button to start copying. When copying is finished, the mode returns to channel to channel copy function setting.

When UP and DOWN buttons are pressed simultaneously, copying is NOT performed, but returns to channel to channel copy function setting.

Channel to channel copy function setting

Press the SET button to set. ↓ Return to function selection mode.

[F95] Channel to channel copy function setting is completed

■[F96] Sensor input display

The sensor input signal (1 to 5 V) can be checked.

<Operation>

Press the UP or DOWN button in function selection mode to display [F96].

Press the SET button. ↓ Move on to the sensor input display.

Sensor input display

Select to display the sensor input by pressing the SET button.

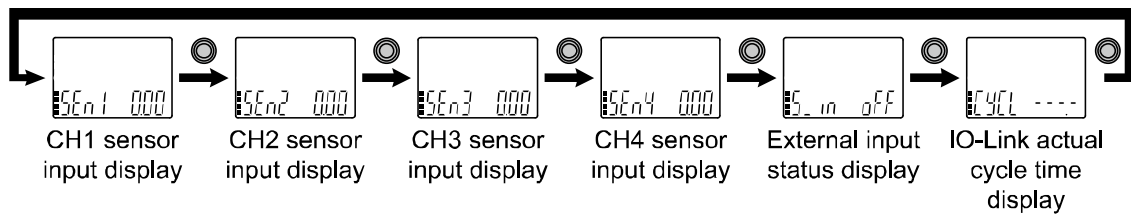

■[F98] Output check

It is possible to check the switch output operation and process data value.
The switch output and process data value can be turned ON/OFF independently.

<Operation>

Press the UP or DOWN button in function selection mode to display [F98].

Press the SET button. ↓ Move on to the output check.

Output check

Press the UP or DOWN button to select output check.

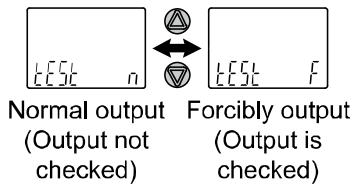

[n] (Normal output) is selected.

Press the SET button to set.

Return to function selection mode

[F] (Forced output) is selected.
Press the SET button to set.

Move on to the OUT1 output check (CH1).

OUT1 output check (CH1)

Press the UP or DOWN button to select OUT1 output check.

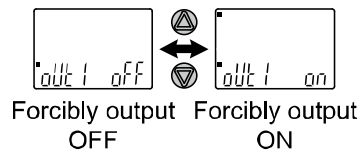

Press the SET button to set.

Move on to the OUT2 output check (CH1).

OUT2 output check (CH1)

Press the UP or DOWN button to select OUT2 output check.

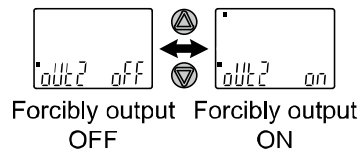

Press the SET button to set.

Move on to the OUT1 output check (CH2).

OUT1 output check (CH2)

Press the UP or DOWN button to select OUT1 output check.

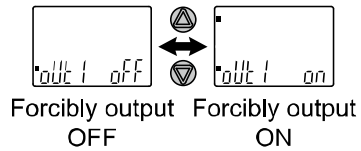

Press the SET button to set.

↓ Move on to the OUT2 output check (CH2).

OUT2 output check (CH2)

Press the UP or DOWN button to select OUT2 output check.

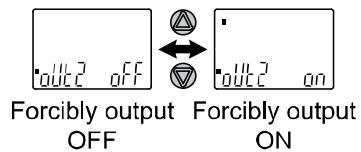

*: IO-Link mode can provide the communication function.

Press the SET button to set.

↓ Move on to the OUT1 output check (CH3).

OUT1 output check (CH3)

Press the UP or DOWN button to select OUT1 output check.

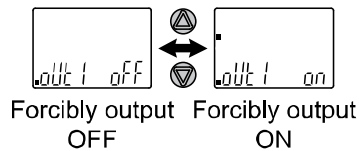
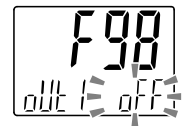

Press the SET button to set.

↓ Move on to the OUT2 output check (CH3).

OUT2 output check (CH3)

Press the UP or DOWN button to select OUT2 output check.

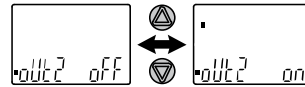

Forcibly output OFF Forcibly output ON

*: IO-Link mode can provide the communication function.

Press the SET button to set.

Move on to the OUT1 output check (CH4).

OUT1 output check (CH4)

Press the UP or DOWN button to select OUT1 output check.

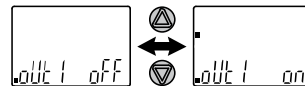

Forcibly output OFF Forcibly output ON

Press the SET button to set.

Move on to the OUT2 output check (CH4).

OUT2 output check (CH4)

Press the UP or DOWN button to select OUT2 output check.

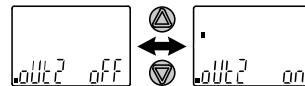
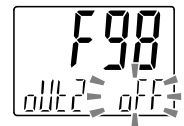

Forcibly output OFF Forcibly output ON

*: IO-Link mode can provide the communication function.

Press the SET button to set.

Move on to the diagnostic output check (CH1).

Diagnostic output check (CH1)

Press the UP or DOWN button to select diagnostic output check.

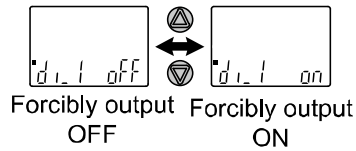

*: IO-Link mode can provide the communication function.

*: Refer to page 72 for details of the diagnostic information.

Press the SET button to set.

Move on to the diagnostic output check (CH2).

Diagnostic output check (CH2)

Press the UP or DOWN button to select diagnostic output check.

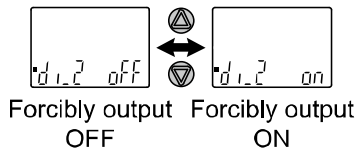

*: IO-Link mode can provide the communication function.

*: Refer to page 72 for details of the diagnostic information.

Press the SET button to set.

Move on to the diagnostic output check (CH3).

Diagnostic output check (CH3)

Press the UP or DOWN button to select diagnostic output check.

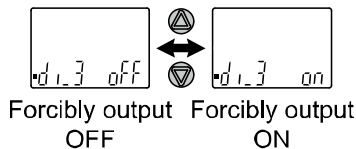

*: IO-Link mode can provide the communication function.

*: Refer to page 72 for details of the diagnostic information.

Press the SET button to set.

Move on to the diagnostic output check (CH4).



Diagnostic output check (CH4)

Press the UP or DOWN button to select diagnostic output check.

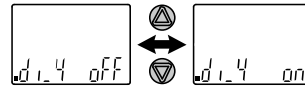

Forcibly output OFF Forcibly output ON

*: IO-Link mode can provide the communication function.

*: Refer to page 72 for details of the diagnostic information.

Press the SET button to set.  Move on to the error diagnostic.

Error diagnostic

Press the UP or DOWN button to select error diagnostic.

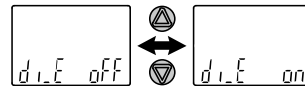

Forcibly output OFF Forcibly output ON

*: IO-Link mode can provide the communication function.

*: Refer to page 72 for details of the error diagnostic.

Press the SET button to set.  Move on to the process data measurement value output check (CH1).

Process data measurement value output check (CH1)

The upper and lower limit values of the rated flow value can be output compulsively as PD measurement value (process data). Press the UP or DOWN button to select the lower or upper limit value.

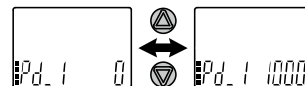
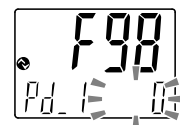

Output of the PD measurement value is ON at the rated lower limit value Output of the PD measurement value is ON at the rated upper limit value

*: IO-Link mode can provide the communication function.

*: Refer to page 72 for details of the PD measurement value.

Press the SET button to set.  Move on to the process data measurement value output check (CH2).



Process data measurement value output check (CH2)

The upper and lower limit values of the rated flow value can be output compulsively as PD measurement value (process data). Press the UP or DOWN button to select the lower or upper limit value.

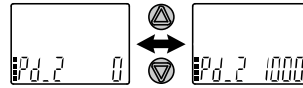

Output of the PD measurement value is ON at the rated lower limit value

Output of the PD measurement value is ON at the rated upper limit value

- *: IO-Link mode can provide the communication function.
- *: Refer to page 72 for details of the PD measurement value.

Press the SET button to set.

Move on to the process data measurement value output check (CH3).

Process data measurement value output check (CH3)

The upper and lower limit values of the rated flow value can be output compulsively as PD measurement value (process data). Press the UP or DOWN button to select the lower or upper limit value.

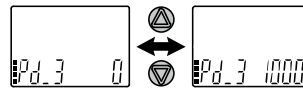
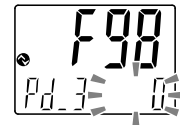

Output of the PD measurement value is ON at the rated lower limit value

Output of the PD measurement value is ON at the rated upper limit value

- *: IO-Link mode can provide the communication function.
- *: Refer to page 72 for details of the PD measurement value.

Press the SET button to set.

Move on to the process data measurement value output check (CH4).

Process data measurement value output check (CH4)

The upper and lower limit values of the rated flow value can be output compulsively as PD measurement value (process data). Press the UP or DOWN button to select the lower or upper limit value.

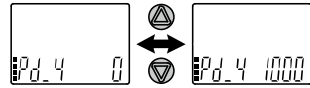

Output of the PD measurement value is ON at the rated lower limit value

Output of the PD measurement value is ON at the rated upper limit value

*: IO-Link mode can provide the communication function.

*: Refer to page 72 for details of the PD measurement value.

Press the SET button to return to [n] (normal output), then press the SET button to set.

Return to function selection mode.

Press the SET button for 2 seconds or longer.

[F98] Output check is completed

Measurement mode

*: Measurement mode can return from any setting item by pressing the SET button for 2 seconds or longer.

■[F99] Reset to default settings

If the product settings are uncertain, the default values can be restored.

*: All channels return to default condition.

<Operation>

Press the UP or DOWN button in function selection mode to display [F99].

Press the SET button. ↓ Move on to the reset to default settings.

Reset to default settings

Press the UP or DOWN button to display [ON], then press the SET and DOWN buttons simultaneously for 5 second or longer.

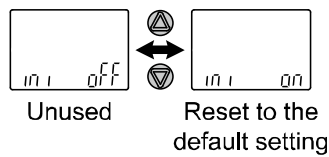

[oFF] (not use) is selected.
Press the SET button to set.

Return to function selection mode.



All settings are returned to the default values. Return to function selection mode.



[F99] Reset to default settings is completed

Other Settings

○Channel scan function

•Press the UP button for 2 seconds or longer. Channels and the measured flows will be displayed in order approximately every 2 seconds.

•The function can be released by pressing the UP button again for 2 seconds or longer.

*: Channel scan function will remain even when the power supply is turned off.

*: During channel scan, setting is disabled other than channel scan mode release and key lock function setting.

Release the channel scan mode when changing settings.

○Snap shot function

The current flow value can be stored to the switch output ON/OFF set point.

When the items of sub display (left) below are selected in 3 step setting mode, simple setting mode or function selection mode ([F 1] Setting of OUT1, [F 2] Setting of OUT2), by pressing the UP and DOWN buttons simultaneously for 1 second or longer, the value of the sub display (right) shows [- - -], and the values corresponding to the current flow values are automatically displayed.

Output mode	Configurable items	Sub display (left)	Snap shot function
Hysteresis mode	Set value	$P_{-1} (n_{-1}) / P_{-2} (n_{-2})$	○
	Hysteresis	H_{-1} / H_{-2}	○
Window comparator mode	Set value	$P_{1L} (n_{1L}), P_{1H} (n_{1H})$ $P_{2L} (n_{2L}), P_{2H} (n_{2H})$	○
	Hysteresis	H_{1L} / H_{1H}	×

•Set value

The value is set to the same value as the display value (current flow value).

(There is a range which cannot be set to the current flow depending on the hysteresis. In that case, the value is set to the closest value.)

•Hysteresis

The hysteresis is calculated from the equation below and set.

Normal output: (set value) - (current flow value)
Reverse output: (current flow value) - (set value)

If the calculation result becomes 0 or less, [Err] is displayed on the sub display (right) and the set value is not changed.

Afterwards, it is possible to adjust the value by pressing the UP or DOWN button.

○Peak/bottom value indication

The maximum (minimum) flow when the power is supplied is detected and updated.

In peak/bottom indication mode, the current flow is displayed.

Press the DOWN button in measurement mode to switch the sub-display (left) to the display shown below. Peak/bottom values are displayed on the sub display (right) at the same time as the current flow value on the main display.

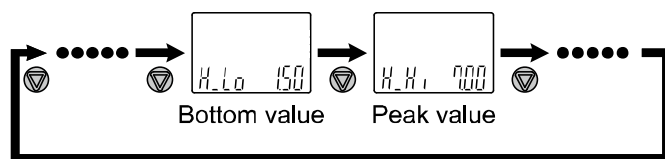

When the SET and DOWN buttons are pressed for 1 second or longer simultaneously while the peak/bottom values are displayed, the sub display (right) displays [- - -] and the maximum (minimum) flow value are cleared.

*: Peak/ bottom value are not stored to memory.

○Key-lock function

The key-lock function is used to prevent errors occurring due to unintentional changes of the set values. If the SET button is pressed while the keys are locked, [LoC] is displayed on the sub display (left) for approximately 1 second.

(Each setting and peak/bottom values are displayed with UP and DOWN buttons.)

<Operation - Without security code input ->

- (1) Press the SET button for 5 seconds or longer in measurement mode. When [oPE] is displayed on the main display, release the button.

The current setting [LoC] or [UnLoC] will be displayed on the sub display.

(To release key-lock repeat the above operation.)

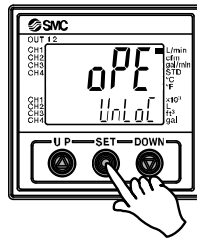

- (2) Select the key-locking/un-locking with UP or DOWN button, and press the SET button to set.

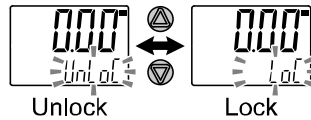

<Operation – With security code input ->

•Locking

- (1) Press the SET button for 5 seconds or longer in measurement mode. When [oPE] is displayed on the main display, release the button.

The current setting [LoC] or [UnLoC] will be displayed on the sub display.

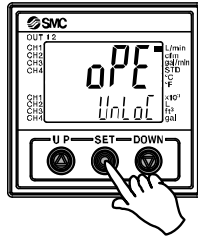

- (2) Select the key [LoC] with UP or DOWN button, and press the SET button to set.

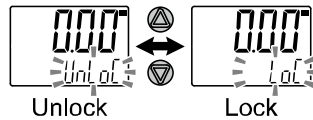

•Unlocking

- (1) Press the SET button for 5 seconds or longer in measurement mode. When [oPE] is displayed on the main display, release the button.

The current setting [LoC] or [UnLoC] will be displayed on the sub display.

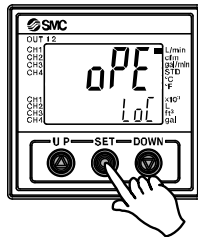

- (2) Select the un-locking [UnLoC] with UP or DOWN button. Setting is recognized by pressing the SET button, then security code is required.

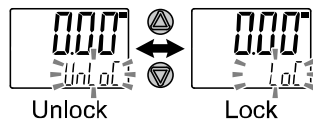

- (3) For instructions on how to enter the security code, refer to "How to input and change the security code" on page 70.

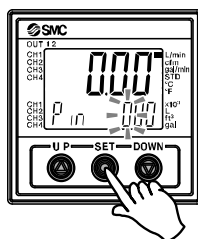

- (4) If inputted security code is correct, the indication of the main display changes to [UnLoC], and pressing the one of UP, SET or DOWN button releases key-lock and the measurement mode returns. If the security code entered is incorrect, [FAL] will be displayed, and the security code must be entered again. If the wrong security code is entered 3 times, [LoC] is displayed and the device returns to measurement mode.

● **How to input and change the security code**

The left most digit starts flashing.

Press the UP or DOWN button to select a value.

Press the SET button to make the next digit to the right flash.

(If the SET button is pressed at the last digit, the first digit will start flashing.)

After the setting is complete, Press and hold the SET button for 1 second or longer.

(If an operation is not performed for 30 seconds during input or change of the security code, it will return to measurement mode.)

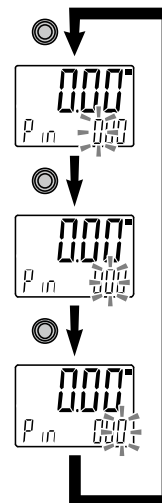

IO-Link Specifications

■ Outline of IO-Link functions

○ Communication function

This product can check the flow measurement value, diagnostic information and switch output status using cyclic data communication via the IO-Link system.

○ Product status monitoring function

This function monitors the product status via the IO-Link communication.

- Detects the error status (internal hardware error).
- Detects the warning conditions (measurement flow error).

○ Data storage function

The Data storage function stores the IO-Link device parameter settings to the IO-Link master.

With the IO-Link data storage function, the IO-Link device can be replaced easily without re-setting the equipment construction or setting parameters

When the device parameters are set and downloaded to the device using the IO-Link setting tool, the parameters in the downloaded device will be activated.

After that, these parameters are uploaded to the data storage in the master by stem command (back-up communication command).

When the device is replaced with the same type of IO-Link device due to failure, the parameter settings stored in the master are downloaded automatically, device can be operated with the parameter settings of the previous device.

Device parameter setting is applicable to 3 types of back-up levels of the master setting ("Inactive", "back-up/Restore", "Restore").

"Back-up" implies the activation of upload and "restore" implies download.

■ Communication specifications

IO-Link type	Device
IO-Link version	V.1.1
Communication speed	COM2 (38.4 kbps)
Min. cycle time	4.8 ms
Process data length	Input Data: 10 byte, Output Data: 0 byte
On request data communication	Available
Data storage function	Available
Event function	Available

■ Process data

Process data is the data which is exchanged periodically between the master and device.

This product process data consists of switch output status, error diagnostics and flow measurement value. (Refer to the table below.)

Bit offset	Item	Notes
0	CH1: OUT1 output	0: OFF 1: ON
1	CH1: OUT2 output	0: OFF 1: ON
2	CH2: OUT1 output	0: OFF 1: ON
3	CH2: OUT2 output	0: OFF 1: ON
4	CH3: OUT1 output	0: OFF 1: ON
5	CH3: OUT2 output	0: OFF 1: ON
6	CH4: OUT1 output	0: OFF 1: ON
7	CH4: OUT2 output	0: OFF 1: ON
8	CH1: Diagnostics	0: OFF 1: ON Out of CH1 display range (When HHH and LLL are displayed).
9	CH2: Diagnostics	0: OFF 1: ON Out of CH2 display range (When HHH and LLL are displayed).
10	CH3: Diagnostics	0: OFF 1: ON Out of CH3 display range (When HHH and LLL are displayed).
11	CH4: Diagnostics	0: OFF 1: ON Out of CH4 display range (When HHH and LLL are displayed).
12	—	Reservation
13	Fixed output	0: Normal output 1: Fixed output
14	Error	0: Normal 1: Abnormal
15	System error	0: Normal 1: Abnormal
16 to 31	CH4: Flow measurement value	With symbol 16 bit
32 to 47	CH3: Flow measurement value	With symbol 16 bit
48 to 63	CH2: Flow measurement value	With symbol 16 bit
64 to 79	CH1: Flow measurement value	With symbol 16 bit

Bit offset	79	78	77	76	75	74	73	72	71	70	69	68	67	66	65	64
Item	CH1: Flow measurement value (PD)															

Bit offset	63	62	61	60	59	58	57	56	55	54	53	52	51	50	49	48
Item	CH2: Flow measurement value (PD)															

Bit offset	47	46	45	44	43	42	41	40	39	38	37	36	35	34	33	32
Item	CH3: Flow measurement value (PD)															

Bit offset	31	30	29	28	27	26	25	24	23	22	21	20	19	18	17	16
Item	CH4: Flow measurement value (PD)															

Bit offset	15	14	13	12	11	10	9	8	7	6	5	4	3	2	1	0
Item	System error	Error	Fixed output	Reservation	Diagnosis CH4	Diagnosis CH3	Diagnosis CH2	Diagnosis CH1	OUT2 CH4	OUT1 CH4	OUT2 CH3	OUT1 CH3	OUT2 CH2	OUT1 CH2	OUT2 CH1	OUT1 CH1

•The process data of this product is Big-Endian type.

When the transmission method of the upper communication is Little-Endian, the byte order will be changed. Refer to the table below for the Endian type of the major upper communication.

Endian type	Upper communication protocol
Big-Endian type	Such as PROFIBUS and PROFINET
Little-Endian type	Such as EtherNET/IP, EtherCAT and CC-Link IE Field.

○Measurement and setting range

Applicable products	Range	Unit	Rated flow range			Display/settable range		
			A	to	B	C	to	D
PF2W5	4 L	Flow L/min	0.50	to	4.00	0.35	to	4.50
		Flow gal/min	0.13	to	1.06	0.09	to	1.19
		PD	125	to	1000	88	to	1125
	16 L	Flow L/min	2.0	to	16.0	1.7	to	17.0
		Flow gal/min	0.55	to	4.25	0.45	to	4.50
		PD	125	to	1000	106	to	1063
	40 L	Flow L/min	5.0	to	40.0	3.5	to	45.0
		Flow gal/min	1.3	to	10.6	0.9	to	11.9
		PD	125	to	1000	88	to	1125
	100 L	Flow L/min	10	to	100	7	to	110
		Flow gal/min	2.6	to	26.4	1.8	to	29.0
		PD	100	to	1000	70	to	1100
	250 L	Flow L/min	50	to	250	20	to	280
		Flow cfm	13	to	66	5	to	74
		PD	200	to	1000	80	to	1120
50 °C	Temperature °C	0	to	100	-10	to	110	
	Temperature °F	32	to	212	14	to	230	
	PD	0	to	1000	-100	to	1100	
PF2A5	10 L	Flow L/min	0.0	to	10.0	0.0	to	10.5
		Flow gal/min	0.000	to	0.353	0.000	to	0.370
		PD	0	to	1000	0	to	1050
	50 L	Flow L/min	0.0	to	50.0	0.0	to	52.5
		Flow gal/min	0.00	to	1.76	0.00	to	1.86
		PD	0	to	1000	0	to	1050
	100 L	Flow L/min	0	to	100	0	to	105
		Flow gal/min	0.00	to	3.53	0.00	to	3.70
		PD	0	to	1000	0	to	1050
	200 L	Flow L/min	0	to	200	0	to	210
		Flow gal/min	0.0	to	7.1	0.	to	7.4
		PD	0	to	1000	0	to	1050
	500 L	Flow L/min	0	to	500	0	to	525
		Flow gal/min	0.0	to	17.6	0.	to	18.6
		PD	0	to	1000	0	to	1050
PF2D5	4 L	Flow L/min	0.40	to	4.00	0.25	to	4.50
		Flow gal/min	0.11	to	1.06	0.07	to	1.19
		PD	100	to	1000	63	to	1125
	20L	Flow L/min	1.8	to	20.0	1.3	to	21.0
		Flow gal/min	0.45	to	5.30	0.35	to	5.55
		PD	90	to	1000	65	to	1050
	40 L	Flow L/min	4.0	to	40.0	2.5	to	45.0
		Flow gal/min	1.1	to	10.6	0.7	to	11.9
		PD	200	to	1000	63	to	1125

○ Conversion formula of the process data and measurement value

(1) Conversion formula from the process data to the measurement value:

$$Pr = a \times (PD) + b$$

(2) Conversion formula from the measurement value to the process data:

$$(PD) = (Pr - b) / a$$

Pr: Measurement value and directive value

PD: Measurement value (process data)

a: Inclination

b: Intercept

[Inclination and intercept to the unit specification]

Applicable products	Unit	Range	Inclination a	Intercept b
PF2W5	L/min	4 L/min	0.004	0
		16 L/min	0.016	0
		40 L/min	0.04	0
		100 L/min	0.1	0
		250 L/min	0.25	0
	gal/min	4 L/min	0.001057	0
		16 L/min	0.004225	0
		40 L/min	0.01057	0
		100 L/min	0.02642	0
		250 L/min	0.066	0
	°C	100 °C	0.1	0
°F	212 °F	0.18	32	
PF2A5	L/min	10 L/min	0.01	0
		50 L/min	0.5	0
		100 L/min	0.1	0
		200 L/min	0.2	0
		500 L/min	0.5	0
	cfm	10 L/min	0.000353	0
		50 L/min	0.001766	0
		100 L/min	0.003531	0
		200 L/min	0.00706	0
		500 L/min	0.1766	0
PF2D5	L/min	4 L/min	0.01	0
		20 L/min	0.02	0
		40 L/min	0.04	0
	gal/min	4 L/min	0.001057	0
		20 L/min	0.005283	0
		40 L/min	0.01057	0

[Calculation example]

**(1) Conversion from the process data to the flow measurement value
(For range: 16 L/min, unit specification L/min and PD=500)**

$$\begin{aligned}Pr &= a \times (PD) + b \\ &= 0.016 \times 500 + 0 \\ &= 8.00 \text{ [L/min]}\end{aligned}$$

**(2) Conversion from the flow measurement value to the process data
(For range: 100 L/min, unit specification cfm and Pr=2.0[cfm])**

$$\begin{aligned}(PD) &= (Pr - b) / a \\ &= [2.0 - (0)] / (0.00353) \\ &\approx 567\end{aligned}$$

■IO-Link parameter setting

○IODD file

IODD (I/O Device Description) is a definition file which provides all properties and parameters required for establishing functions and communication of the device.

IODD includes the main IODD file and a set of image files such as vendor logo, device picture and device icon.

The IODD file is shown below.

Product No.	IODD file *1
PFG20#	SMC-PFG200-yyyymmdd-IODD1.1

*1: "yyyymmdd" indicates the file preparation date. yyyy is the year, mm is the month and dd is the date.

The IODD file can be downloaded from the SMC Web site (<https://www.smcworld.com>).

○Service data

The tables below indicates the parameters which can be read or written by simple access parameter (direct parameters page) and ISDU parameters which are applicable to various parameters and commands.

*: The parameter data of this product is the Big Endian type.

When the transmission method of the upper communication is Little-Endian, the byte order will be changed.

●Direct parameters page 1

DPP1 address	Access	Parameter name	Initial value (dec)	Contents
0x07	R	Vendor ID	0x0083 (131)	"SMC Corporation"
0x08				
0x09	R	Device ID	0x00028F (655)	"PFG20x-xxxx"
0x0A				
0x0B				

•ISDU parameters

Index (dec)	Sub index	Access *1	Parameters	Initial value	Remarks
0x0002 (2)	0	W	System command	–	Refer to "System command" on page 78.
0x000C (12)	0	R/W *2	Device access lock	0x0000	Refer to "Device access lock parameter" on page 79.
0x0010 (16)	0	R	Vendor name	SMC Corporation	
0x0011 (17)	0	R	Vendor text	www.smcworld.com	
0x0012 (18)	0	R	Product name	Example: PFG200	
0x0013 (19)	0	R	Product ID	Example: PFG200	
0x0014 (20)	0	R	Product text	MONITOR	
0x0015 (21)	0	R	Serial number	Example: "xxxxxxxx"	•Initial value is indicated as 8-digit. •16 octets fixed character string
0x0016 (22)	0	R	Hardware version	HW-Vx.y	x: Large revision number y: Small revision number
0x0017 (23)	0	R	Software version	FW-Vx.y	x: Large revision number y: Small revision number
0x0018 (24)	0	R/W *2	Application specific tag	ALL "*"	Can be changed arbitrarily
0x0024 (36)	0	R	Device status parameter	–	Refer to "Device status parameter" on page 79.
0x0025 (37)	0	R	Device detailed state parameter	–	Refer to "Device detailed state parameter" on page 80.
0x0028 (40)	0	R	Process data input	–	The latest value of process data can be read.

*1: R: Read, W: Write

*2: When using IODD, only the personnel who are registered as Maintenance/Specialist can Write data.

- System command (index 2)

In the ISDU index 0x0002 SystemCommand (system command), the command shown in the table below will be issued.

The button of each system command is displayed on the IO-Link setting tool (excluding "ParamDownloadStore").

Click the button to send the system command to the product.

Writable commands are shown below.

Data type: 8 bit UInteger

Value (dec)	State definition	Description
0x80(128)	Device Reset	Reset the device.
0x81(129)	Application Reset	Clear the peak/bottom value and accumulated of all channels.
0x82(130)	Restore Factory Settings	Restore the set values to the factory settings.
0xAA(170)	All Peak Bottom Clear	Clear the peak/bottom value of all channels.
0xAB(171)	CH1 Peak Bottom Clear	Clear the peak/bottom value of CH1.
0xAC(172)	CH2 Peak Bottom Clear	Clear the peak/bottom value of CH2.
0xAD(173)	CH3 Peak Bottom Clear	Clear the peak/bottom value of CH3.
0xAE(174)	CH4 Peak Bottom Clear	Clear the peak/bottom value of CH4.
0xBE(190)	All Accumu Reset	Clear the accumulated value of all channels.
0xBF(191)	CH1 Accumu Reset	Clear the accumulated value of CH1.
0xC0(192)	CH2 Accumu Reset	Clear the accumulated value of CH2.
0xC1(193)	CH3 Accumu Reset	Clear the accumulated value of CH3.
0xC2(194)	CH4 Accumu Reset	Clear the accumulated value of CH4.

- Device access lock parameter (index 12)

The contents are as follows.

Data type: 16 bit Record

Value (dec)	Contents
0x0000 (0)	Key lock release, DS unlock (Initial value)
0x0002 (2)	Key lock release, DS lock
0x0008 (8)	Key lock, DS unlock
0x000A (10)	Key lock, DS lock

[Key lock]

Function that prevents changes to the settings of the product (disables button operation). Even when key lock function is activated, settings can be changed by IO-Link communication. Restoration by data storage (overwriting parameter data) can be performed.

[Lock data storage (DS lock)]

Data storage function is disabled by locking the Data storage". In this case, access will be denied for backup and restoration of data storage.

- Device state parameters (index 36)

Readable device states are as follows.

Data type: 8 bit UInteger

Value	State definition	Description
0x00 (0)	Normal operation	—
0x01 (1)	Maintenance inspection required	Not available
0x02 (2)	Outside specification range	The measurement range has exceeded the upper limit
0x03 (3)	Function check	Not available
0x04 (4)	Failure	Internal failure of product

•Device detail status parameters (index 37)

Detailed event contents of readable device status are as follows.

Array	Event content	Event classification		Event code
		Definition	Value	
1	Internal product malfunction	Error	0xF4	0x8D03
2	Internal product malfunction	Error	0xF4	0x8D04
3	Internal product malfunction	Error	0xF4	0x8D05
4	Internal product malfunction	Error	0xF4	0x8D01
5	Internal product malfunction	Error	0xF4	0x8D06
6	OUT 1 over current error of CH2	Error	0xF4	0x8CE1
7	OUT 1 over current error of CH3	Error	0xF4	0x8CE2
8	OUT 1 over current error of CH4	Error	0xF4	0x8CE3
9	OUT 2 over current error of CH1	Error	0xF4	0x8CC0
10	Outside the accumulated measurement of CH1	warning	0xE4	0x8D80
11	Outside the accumulated measurement of CH2	warning	0xE4	0x8D81
12	Outside the accumulated measurement of CH3	warning	0xE4	0x8D82
13	Outside the accumulated measurement of CH4	warning	0xE4	0x8D83
14	Outside the measurement of CH1	warning	0xE4	0x8D60
15	Outside the measurement of CH2	warning	0xE4	0x8D61
16	Outside the measurement of CH3	warning	0xE4	0x8D62
17	Outside the measurement of CH4	warning	0xE4	0x8D63
18	Test event A	warning	0xE4	0x8CA0
19	Test event B	warning	0xE4	0x8CA1
20	Data storage upload request	notification	0x54	0xFF91

●Product individual parameters

Index (dec)				Sub index	Access ^{*1}	Parameter	Data storage ^{*2}	Data type ^{*3}	Initial value (dec)	Remarks
CH1	CH2	CH3	CH4							
0x03F2 (1010)	0x03F3 (1011)	0x03F4 (1012)	0x03F5 (1013)	0	R/W	CoL (Selection of display colour)	Y	U8	0x02 (2)	Setting of display colour. 0: rEd (Constantly red) 1: Grn (Constantly green) 2: 1SoG (OUT1 turns green at ON) 3: 1Sor (OUT1 turns red at ON) 4: 2SoG (OUT2 turns green at ON) 5: 2Sor (OUT2 turns red at ON)
0x0410 (1040)	0x0411 (1041)	0x0412 (1042)	0x0413 (1043)	1	R/W	rAnG (PF2A5, Selection of connection range)	Y	U8	0x00 (0)	Set the connection range of PF2A5. 0: 10 L 1: 50 L 2: 100 L 3: 200 L 4: 500 L
				2	R/W	rAnG (PF2W5, Selection of connection range)	Y	U8	0x00 (0)	Set the connection range of PF2W5. 0: 4 L 1: 16 L 2: 40 L 3: 100 L 4: 250 L
				3	R/W	rAnG (PF2D5, Selection of connection range)	Y	U8	0x00 (0)	Set the connection range of PF2D5. 0: 4 L 1: 20 L 2: 40 L
				4	R/W	Setting of connection product	Y	U8	0x01 (1)	0: PFA (PF2A5) 1: PFW (PF2W5) 2: PFD (PF2D5) 3: USEr (User setting)
				5	R/W	Setting of connection sensor (For PF3W5)	Y	U8	0x00 (0)	0: Flow 1: tEMP
				6	R/W	Unit (Selection of display unit, for PF2A5)	Y	U8	0x00 (0)	0: L 1: Ft
				7	R/W	Unit setting (For PF2W5, PF2D5)	Y	U8	0x00 (0)	0: L 1: GAL
				8	R/W	Temperature unit setting (For PF2W5)	Y	U8	0x00 (0)	0: °C 1: °F
				9	R/W	Udot (Minimum unit for connection product [USEr])	Y	U8	0x06 (6)	Set the minimum unit when "range added by the user" is selected. 0: 0.001 1: 0.002 2: 0.01 3: 0.02 4: 0.1 5: 0.2 6: 1 7: 2
				10	R/W	ULo (Rated lower limit for connection product [USEr])	Y	S16	0x0000 (0)	Set the rated lower limit when "range added by the user" is selected. -1000 ~ 1000
				11	R/W	UHl (Rated upper limit for connection product [USEr])	Y	S16	0x03E8 (1000)	Set the rated upper limit when "range added by the user" is selected. -1000 ~ 1000
				12	R/W	UAC (Accumulated minimum unit for connection product [USEr])	Y	U8	0x01 (1)	Set the accumulated minimum unit when the user's additional range is selected. 0: 0.1 1: 1 2: 10 3: 100
				13	R/W	UPLS (Accumulated volume per pulse for connection product [USEr])	Y	U8	0x02 (2)	Set the accumulated volume per pulse when the user's additional range is selected. 0: 0.1 1: 1 2: 10 3: 100
				14	R/W	Unit setting (USEr is selected)	Y	U8	0x00 (0)	0: L 1: °C 2: Ft 3: GAL 4: °F 5: oFF

●Product individual parameters (continued)

Index (dec)				Sub index	Access ⁺¹	Parameter	Data storage ⁺²	Data type ⁺³	Initial value (dec)	Remarks
CH1	CH2	CH3	CH4							
0x041A (1050)				1	R/W	Channel select	Y	U8	0x00 (0)	Set the channel to be displayed. 0: CH1 1: CH2 2: CH3 3: CH4
				2	R/W	Channel scan mode	Y	U8	0x00 (0)	Set the channel scan mode. 0: OFF 1: ON
0x042E (1070)	0x042F (1071)	0x0430 (1072)	0x0431 (1073)	0	R/W	Setting of reference condition (For PF2A5)	Y	U8	0x00 (0)	0: std 1: nor
0x04BA (1210)	0x04BB (1211)	0x04BC (1212)	0x04BD (1213)	1	R/W	oUt1 (Selection of OUT1 output operation mode, flow)	Y	U8	0x00 (0)	Setting of the flow rate output mode. 0: HYS (Hysteresis) 1: Wind (Window comparator) 2: AC (Accumulated) 3: PLS (Accumulated pulse) 4: Err (Error output) 5: oFF (Output OFF)
				2	R/W	oUt1 (Selection of OUT1 output operation mode, temperature)	Y	U8	0x00 (0)	Setting of the temperature output mode. 0: HYS (Hysteresis) 1: Wind (Window comparator) 2: Err (Error output) 3: oFF (Output OFF)
				3	R/W	1ot (Selection of OUT1 output type)	Y	U8	0x00 (0)	Setting of OUT1 output type. 0: 1_P (Normal output) 1: 1_n (Reverse output)
0x04C4 (1220)	0x04C5 (1221)	0x04C6 (1222)	0x04C7 (1223)	1	R/W	P_1 (OUT1 output set value)	Y	S16	0x01F4 (500)	Setting of OUT1 output set value. (page 73)
				2	R/W	H_1 (Setting of OUT1 hysteresis)	Y	U16	0x0032 (50)	Setting of OUT1 hysteresis. (page 73)
				3	R/W	P1L (Lower limit of the OUT1 window comparator)	Y	S16	0x012C (300)	Setting of OUT1 lower limit of window comparator. (page 73)
				4	R/W	P1H (Upper limit of the OUT1 window comparator)	Y	S16	0x0258 (600)	Setting of OUT1 upper limit of window comparator. (page 73)
				5	R/W	WH1 (Setting of OUT1 window comparator hysteresis)	Y	U16	0x0064 (100)	Setting of OUT1 window comparator hysteresis. (page 73)
				6	R/W	dtH1 (OUT1 delay time at ON)	Y	U16	0x0000 (0)	Setting of OUT1 delay time at ON. 0x0000 ~ 0x1770 (0 ~ 6000) 0.01 s increment
				7	R/W	dtL1 (OUT1 delay time at OFF)	Y	U16	0x0000 (0)	Setting of OUT1 delay time at OFF. 0x0000 ~ 0x1770 (0 ~ 6000) 0.01 s increment
0x0514 (1300)	0x0515 (1301)	0x0516 (1302)	0x0517 (1303)	0	R/W	OUT1 Accumulated threshold value setting (L)	Y	F32	0x00000000 (0)	Consider the accumulated inclination when reading or writing the accumulated value.
0x051E (1310)	0x051F (1311)	0x0520 (1312)	0x0521 (1313)	0	R/W	OUT1 Setting of the accumulated threshold value (Fl3, Gal)	Y	F32	0x00000000 (0)	Consider the accumulated inclination when reading or writing the accumulated value.

●Product individual parameters (continued)

Index (dec)				Sub index	Access ⁺¹	Parameter	Data storage ⁺²	Data type ⁺³	Initial value (dec)	Remarks
CH1	CH2	CH3	CH4							
0x0582 (1410)	0x0583 (1411)	0x0584 (1412)	0x0585 (1413)	1	R/W	oUI2 (Selection of OUT2 output operation mode, flow)	Y	U8	0x00 (0)	Setting of the flow rate output mode. 0: HYS (Hysteresis) 1: Wind (Window comparator) 2: AC (Accumulated) 3: PLS (Accumulated pulse) 4: Err (Error output) 5: oFF (Output OFF)
				2	R/W	oUt2 (Selection of OUT2 output operation mode, temperature)	Y	U8	0x00 (0)	Setting of the temperature output mode. 0: HYS (Hysteresis) 1: Wind (Window comparator) 2: Err (Error output) 3: oFF (Output OFF)
				2	R/W	2ot (Selection of OUT2 output type)	Y	U8	0x00 (0)	Setting of OUT2 output type. 0: 2_P (Normal output) 1: 2_n (Reverse output)
0x058C (1420)	0x058D (1421)	0x058E (1422)	0x058F (1423)	1	R/W	P_2 (OUT2 output set value)	Y	S16	0x01F4 (500)	Setting of OUT2 output set value. (page 73)
				2	R/W	H_2 (Setting of OUT2 hysteresis)	Y	U16	0x0032 (50)	Setting of OUT2 hysteresis. (page 73)
				3	R/W	P2L (Lower limit of the OUT2 window comparator)	Y	S16	0x012C (300)	Setting of OUT2 lower limit of window comparator. (page 73)
				4	R/W	P2H (Upper limit of the OUT2 window comparator)	Y	S16	0x0258 (600)	Setting of OUT2 upper limit of window comparator. (page 73)
				5	R/W	WH2 (Setting of OUT2 window comparator hysteresis)	Y	U16	0x0064 (100)	Setting of OUT2 window comparator hysteresis. (page 73)
				6	R/W	dtH2 (OUT2 delay time at ON)	Y	U16	0x0000 (0)	Setting of OUT1 delay time at ON. 0x0000 ~ 0x1770 (0 ~ 6000) 0.01 s increment
				7	R/W	dtL2 (OUT2 delay time at OFF)	Y	U16	0x0000 (0)	Setting of OUT1 delay time at OFF. 0x0000 ~ 0x1770 (0 ~ 6000) 0.01 s increment
0x05DC (1500)	0x05DD (1501)	0x05DE (1502)	0x05DF (1503)	0	R/W	OUT2 Accumulated threshold value setting (L)	Y	F32	0x00000000 (0)	Consider the accumulated inclination when reading or writing the accumulated value.
0x05E6 (1510)	0x05E7 (1511)	0x05E8 (1512)	0x05E9 (1513)	0	R/W	OUT2 Setting of the accumulated threshold value (Ft3, Gal)	Y	F32	0x00000000 (0)	Consider the accumulated inclination when reading or writing the accumulated value.

●Product individual parameters (continued)

Index (dec)				Sub index	Access ⁺¹	Parameter	Data storage ⁺²	Data type ⁺³	Initial value (dec)	Remarks
CH1	CH2	CH3	CH4							
0x0640 (1600)	0x0641 (1601)	0x0642 (1602)	0x0643 (1603)	0	R/W	AC (Accumulated display direction)	Y	U8	0x0000 (0)	Set the accumulated direction. 0: Add (Addition) 1: dEC (Subtraction OUT1) 2: dEC2 (Subtraction OUT2)
0x0708 (1800)	0x0709 (1801)	0x070A (1802)	0x070B (1803)	0	R/W	FiL (Digital filter)	Y	U16	0x0000 (0)	Setting of digital filter. 0x0000 ~ 0x0BB8 (0 ~ 3000) 0.01 s increment
0x07D0 (2000)	0x07D1 (2001)	0x07D2 (2002)	0x07D3 (2003)	1	R/W	SUB (Setting of sub display option)	Y	U8	0x00 (0)	Set the sub display option. 0: dEF (Default) 1: dUAL (2 value display) 2: LinE (Line name) 3: oFF (Display OFF)
				2	R/W	dEF (Flow default setting)	Y	U8	0x00 (0)	Refer to Table "Selection of display items during dEF setting".
				3	R/W	dUAL (Left side of sub display (2 value display is selected))	Y	U8	0x00 (0)	Refer to Table "2 value display communication data".
				4	R/W	dUAL (Right side of sub display (2 value display is selected))	Y	U8	0x01 (1)	
0x07EE (2030)	0x07EF (2031)	0x07F0 (2032)	0x07F1 (2033)	0	R/W	CUt (Zero cut-off setting)	Y	U8	0x05 (5)	Set the zero-cut range. 0x00 ~ 0x0A (0 ~ 10) 1.0% increment
0x07F8 (2040)				0	R/W	inP (External input setting)	Y	U8	0x01 (1)	Set the external input setting. 0: oFF (Not used) 1: rAC (Reset accumulated value) 2: rPb (Peak/bottom clear)
0x0816 (2070)	0x0817 (2071)	0x0818 (2072)	0x0819 (2073)	0	R/W	EXin (Enable/disable external input)	Y	U8	0x01 (1)	Set the enable/disable of external input of each CH. 0: OFF (Disabled) 1: ON (Enabled)
0x0898 (2200)				0	R/W	SAVE (Accumulated hold setting)	Y	U8	0x00 (0)	Set the accumulated hold function. 0: oFF (Not used) 1: 5.0 min

●Product individual parameters (continued)

Index (dec)				Sub index	Access ⁺¹	Parameter	Data storage ⁺²	Data type ⁺³	Initial value (dec)	Remarks
CH1	CH2	CH3	CH4							
0x0974 (2420)	0x0975 (2421)	0x0976 (2422)	0x0977 (2423)	1	R/W	Line name 1st letter (11 SEG)	Y	U8	0x00 (0)	Refer to Figure "Line name communication data (11 seg)".
				2	R/W	Line name 2nd letter (11 SEG)	Y	U8	0x00 (0)	Refer to Figure "Line name communication data (11 seg)".
				3	R/W	Line name 3rd letter	Y	U8	0x00 (0)	Refer to Figure "Line name communication data (7 seg)".
				4	R/W	Line name 4th letter	Y	U8	0x00 (0)	Refer to Figure "Line name communication data (7 seg)".
				5	R/W	Line name 5th letter	Y	U8	0x00 (0)	Refer to Figure "Line name communication data (7 seg)".
				6	R/W	Line name 6th letter (11 SEG)	Y	U8	0x00 (0)	Refer to Figure "Line name communication data (11 seg)".
				7	R/W	Line name 7th letter (11 SEG)	Y	U8	0x00 (0)	Refer to Figure "Line name communication data (11 seg)".
				8	R/W	Line name 8th letter	Y	U8	0x00 (0)	Refer to Figure "Line name communication data (7 seg)".
				9	R/W	Line name 9th letter	Y	U8	0x00 (0)	Refer to Figure "Line name communication data (7 seg)".
0x097E (2430)	0x097F (2431)	0x0980 (2432)	0x0981 (2433)	1	R/W	Line name 1st letter dot	Y	U8	0x00 (0)	0: OFF (dot OFF) 1: ON (dot ON)
				2	R/W	Line name 2nd letter dot	Y	U8	0x00 (0)	0: OFF (dot OFF) 1: ON (dot ON)
				3	R/W	Line name 3rd letter dot	Y	U8	0x00 (0)	0: OFF (dot OFF) 1: ON (dot ON)
				4	R/W	Line name 4th letter dot	Y	U8	0x00 (0)	0: OFF (dot OFF) 1: ON (dot ON)
				5	R/W	Line name 5th letter dot	Y	U8	0x00 (0)	0: OFF (dot OFF) 1: ON (dot ON)
				6	R/W	Line name 6th letter dot	Y	U8	0x00 (0)	0: OFF (dot OFF) 1: ON (dot ON)
				7	R/W	Line name 7th letter dot	Y	U8	0x00 (0)	0: OFF (dot OFF) 1: ON (dot ON)
				8	R/W	Line name 8th letter dot	Y	U8	0x00 (0)	0: OFF (dot OFF) 1: ON (dot ON)
0x0960 (2400)				0	R/W	EC0 (ECO mode)	Y	U8	0x00 (0)	Set the economy mode. 0: OFF 1: ON
0x096A (2410)				1	R/W ⁺⁵	Pin (Security code Used/Not used)	Y	U8	0x00 (0)	Setting of the security code to used or not used. 0: OFF 1: ON
				2	R/W ⁺⁵	PinCode (Security code)	Y	U16	0x0000 (0)	Setting of security code. 0x0000 ~ 0x03E7 (0 ~ 999)

●Product individual parameters (continued)

Index (dec)				Sub index	Access ^{*1}	Parameter	Data storage ^{*2}	Data type ^{*3}	Initial value (dec)	Remarks
CH1	CH2	CH3	CH4							
0x1B58 (7000)				0	R/W	test (Output signal check)	N	U8	0x00 (0)	When a fixed output is received: Set the bit in PD to 1. 0: Normal output 1: Fixed output
0x1B62 (7010)				0	W	Toggle (Toggle output)	N	U8	-	Refer to Table "Toggle output command".
0x1F40 (8000)	0x1F41 (8001)	0x1F42 (8002)	0x1F43 (8003)	0	R	Process data Conversion formula Inclination a	N	F32	-	Refer to Table "Inclination and intercept to the unit specification". (page 74)
0x1F4A (8010)	0x1F4B (8011)	0x1F4C (8012)	0x1F4D (8013)	0	R	Process data Conversion formula Intercept b	N	F32	-	
0x1F54 (8020)	0x1F55 (8021)	0x1F56 (8022)	0x1F57 (8023)	0	R	H_Hi (Peak value)	N	S16	-	Refer to process data on page 72 to 75.
0x1F5E (8030)	0x1F5F (8031)	0x1F60 (8032)	0x1F61 (8033)	0	R	H_Lo (Bottom value)	N	S16	-	
0x1F68 (8040)	0x1F69 (8041)	0x1F6A (8042)	0x1F6B (8043)	0	R	Accumulated measurement value	N	F32	-	Reply the value according to the current unit reference condition. Range of accumulated measurement value: 0 to 999,999,999
0x1F7C (8060)	0x1F7D (8061)	0x1F7E (8062)	0x1F7F (8063)	0	R	Accumulated inclination a	N	F32	-	
0x1F86 (8070)	0x1F87 (8071)	0x1F88 (8072)	0x1F89 (8073)	0	R	Accumulated intercept b	N	F32	-	Conversion equation for accumulated display: Accumulated measurement value x Accumulated inclination a + Accumulated intercept b
0x1F9A (8090)	0x1F9B (8091)	0x1F9C (8092)	0x1F9D (8093)	1	R	Rated range lower limit	N	S16	-	
				2	R	Rated range upper limit	N	S16	-	
				3	R	Measurable range lower limit	N	S16	-	
				4	R	Measurable range upper limit	N	S16	-	
				5	R	Settable range lower limit	N	S16	-	
				6	R	Settable range upper limit	N	S16	-	

*1: "R" means Read and "W" means Write.

When using IODD, only the personnel who are registered as Maintenance/Specialist can write other than the channel select and channel scan (0x41A).

*2: "Y" indicates that the parameter setting data is saved to the master, and "N" indicates that the parameter is not saved.

*3: Refer to the table below for the symbol.

Symbol	Data type (IO-Link standard)	Data length Bit [byte]	Description
U8	UIntegerT	8 [1]	Unsigned integer
U16		16 [2]	
S16	IntegerT	16 [2]	Signed integer
F32	Float32T	32 [4]	Floating point number

*4: Read/write to items that cannot be set will be rejected depending on the product model and selection of the connection product.

*5: When using IODD, only the personnel who are registered as Maintenance/Specialist can read and write data.

[Selection of display items during dEF setting]

Value	Setting content	Supplemental information	
0	HYS mode set value	When the value which does not match the OUT* output mode setting is written, acknowledgment is sent and [dEF - - -] is displayed.	
	HYS mode hysteresis		
	Wind mode lower side set value		
	Wind mode upper side set value		
	Wind mode hysteresis		
	AC mode set value		
	PLS mode		
	Err mode		
	oFF mode		
	OUT1		HYS mode set value
			HYS mode hysteresis
			Wind mode lower side set value
			Wind mode upper side set value
			Wind mode hysteresis
AC mode set value			
PLS mode			
Err mode			
oFF mode			
OUT2	HYS mode set value		
	HYS mode hysteresis		
	Wind mode lower side set value		
	Wind mode upper side set value		
	Wind mode hysteresis		
	AC mode set value		
	PLS mode		
	Err mode		
oFF mode			
	Instantaneous flow bottom value		
	Instantaneous flow peak value		
	Accumulated flow measurement display		
	IO-Link mode display	SIO mode/SDCI mode display	
	Option display	2 value display, Line name display, Display OFF	

[2 value display communication data]

Value	Setting content		Selection of display items during 2 value setting		Supplemental information
			Left side	Right side	
0	OUT1	HYS mode set value	●	●	When the value which does not match the OUT* output mode setting is written, acknowledgment is sent and [- - -] is displayed.
1		HYS mode hysteresis	●	●	
2		Wind mode lower side set value	●	●	
3		Wind mode upper side set value	●	●	
4		Wind mode hysteresis	●	●	
5	OUT2	HYS mode set value	●	●	
6		HYS mode hysteresis	●	●	
7		Wind mode lower side set value	●	●	
8		Wind mode upper side set value	●	●	
9		Wind mode hysteresis	●	●	
10	Instantaneous flow peak value		●	×	
11	Instantaneous flow bottom value		×	●	
12	Display unit		●	●	
13	Range specification		●	●	
14	OUT1 output mode/output style		●	×	
15	OUT2 output mode/output style		×	●	
16	Line name (left side 4 digits, right side 5 digits)		●	●	
17	Display channel		●	●	
18	CH1 measurement display value		●	●	
19	CH2 measurement display value		●	●	
20	CH3 measurement display value		●	●	
21	CH4 measurement display value		●	●	
22	Display OFF (No display)		●	●	

●: Settable

×: Not settable (negative acknowledge)

[Line name communication data]

Value (16 Hex number)		00	01	02	03	04	05	06	07	08	09	0A	0B	0C	0D	0E	0F
Display letter	7seg																
	11seg																
Value (16 Hex number)		10	11	12	13	14	15	16	17	18	19	1A	1B	1C	1D	1E	1F
Display letter	7seg																
	11seg																
Value (16 Hex number)		20	21	22	23	24	25	26	27	28	29	2A	2B	2C	2D	2E	2F
Display letter	7seg																
	11seg																
Supplementary information	: Do not work																

[Toggle output command]

Value		Item	Remarks
0	Measurement value	CH1	
1		CH2	
2		CH3	
3		CH4	
16	OUT output	CH1_OUT1	Connected with hardware output
17		CH1_OUT2	
18		CH2_OUT1	
19		CH2_OUT2	
20		CH3_OUT1	
21		CH3_OUT2	
22		CH4_OUT1	
23		CH4_OUT2	
224	CH * Diagnosis bit	CH1	
225		CH2	
226		CH3	
227		CH4	
254	Error bit	Excluding system error	
255		System error	

Maintenance

How to reset the product after a power cut or forcible de-energizing

The setting of the product will be retained as it was before a power cut or de-energizing. The output condition is also basically recovered to that before a power cut or de-energizing, but may change depending on the operating environment. Therefore, check the safety of the whole installation before operating the product. If the installation is using accurate control, wait until the product has warmed up (approximately 10 to 15 minutes).

Forgotten the security code

If you have forgotten your security code, please contact SMC directly.

Troubleshooting

○Troubleshooting

When any failure occurs with this product, the following chart can be used to identify the cause of the failure. If a cause applicable to the troubles cannot be identified and normal operation is recovered by replacement with a new product, this indicates that the product itself was faulty. Problems with the product may be due to the operating environment (installation etc). Please consult SMC.

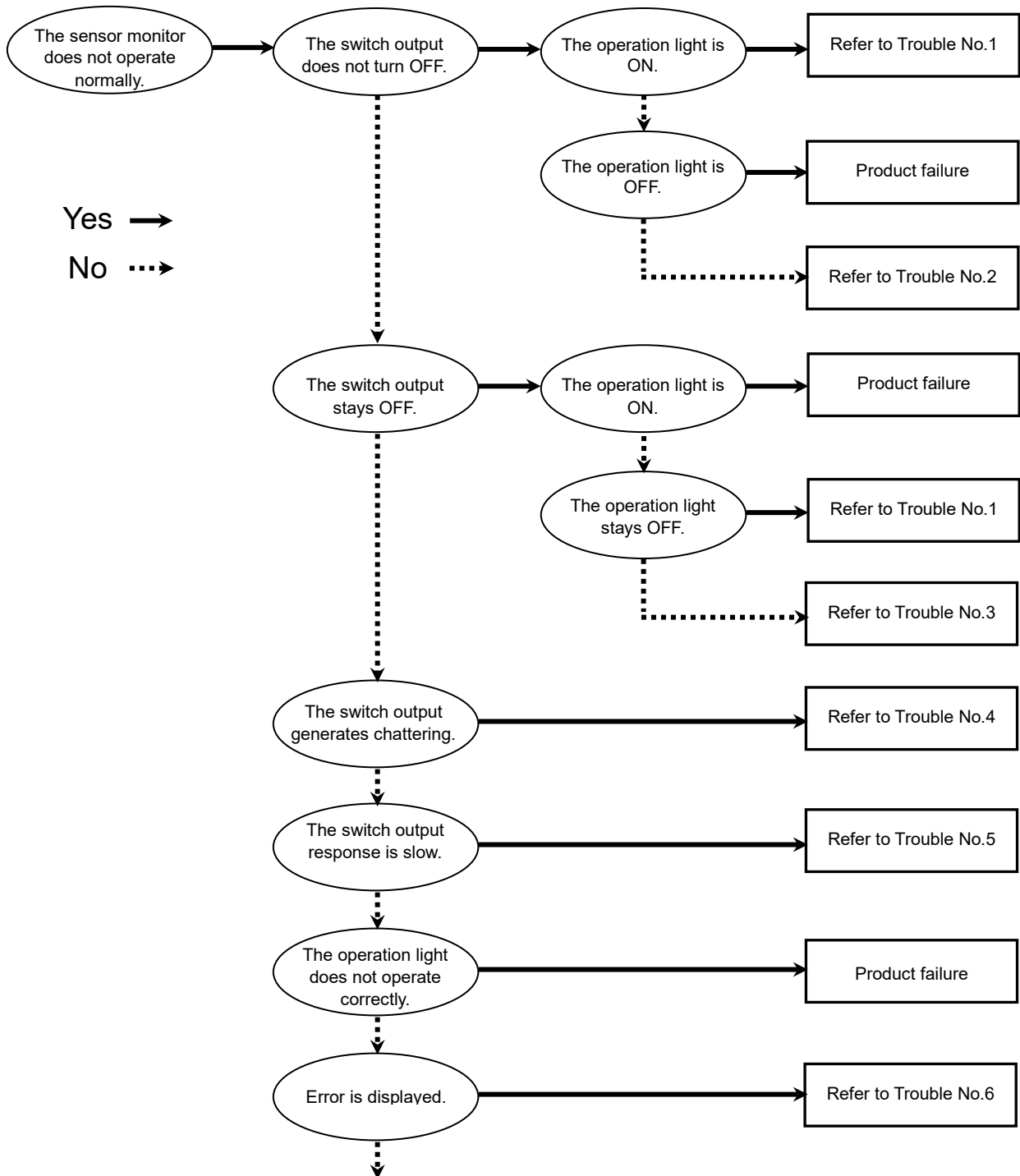

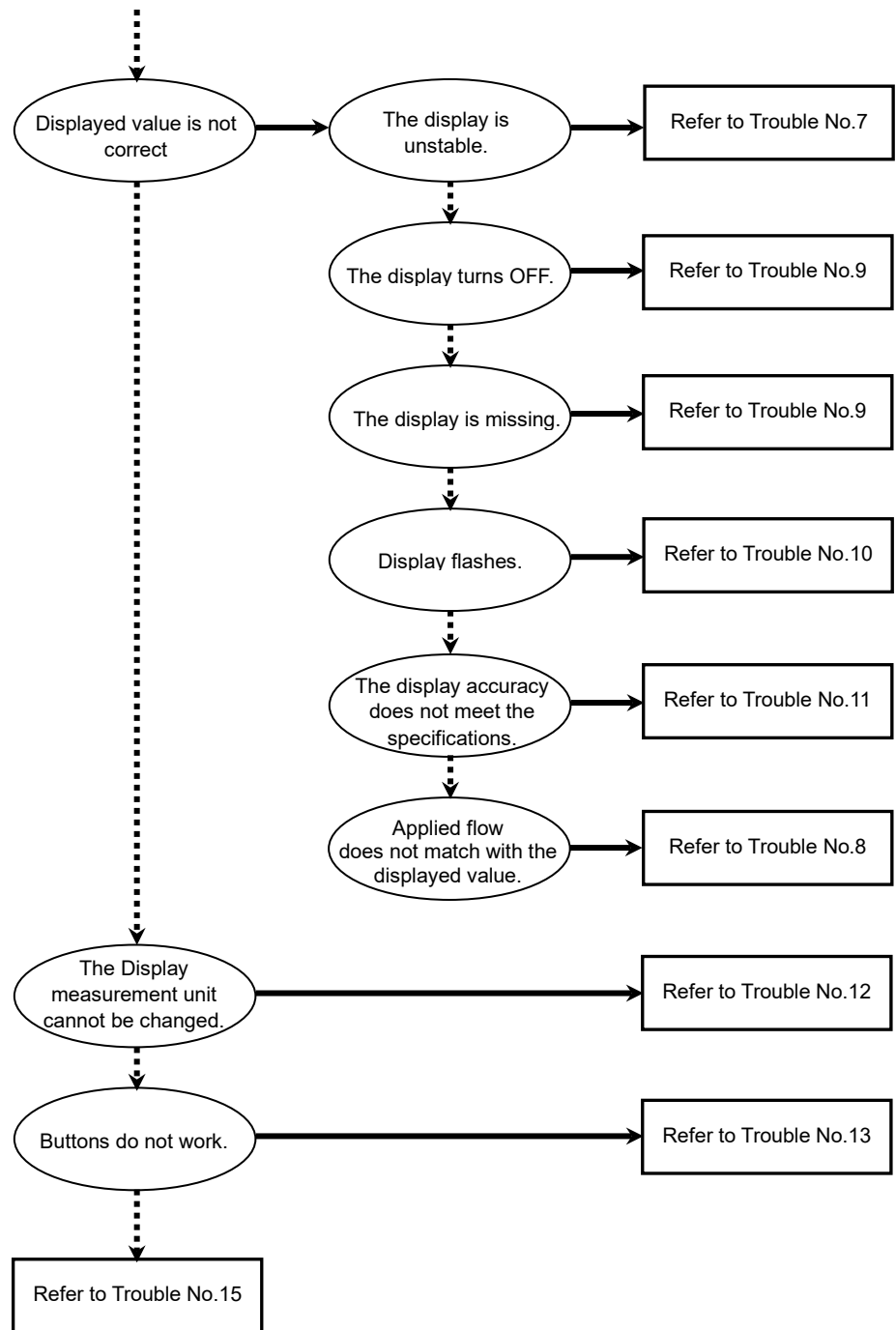

○Troubleshooting list

Problem No.	Problem	Problem possible causes	Investigation method	Countermeasures
1	<ul style="list-style-type: none"> •The switch output does not turn OFF. The operation light stays ON. •The switch output does not turn ON. The operation light stays OFF. 	Incorrect flow setting	(1) Check the set flow value. (2) Check the settings of the operation mode, hysteresis and output type. (In hysteresis mode or window comparator mode, and normal output/ reversed output)	(1) Adjust the set flow value. (2) Set the operation mode, hysteresis and output type again.
		Product failure		Replace the product.
2	The switch output does not turn OFF. The operation light is normal.	Incorrect wiring	Check the output wiring. Check if the load is directly connected to DC(+) or DC(-).	Check and correct the wiring.
		Product failure		Replace the product.
3	The switch output is OFF. The operation light is normal.	Incorrect wiring	Check the output wiring. Check if the load is directly connected to DC(+) or DC(-).	Check and correct the wiring.
		Model selection	Check if PNP output is used when NPN should have been selected, or the other way around.	Revise the model selection (output specification).
		Lead wire broken	Check if there is bending stress applied to any part of the lead wire. (bending radius, tensile force to the lead wire)	Correct the wiring. (Reduce the tensile force or increase the bending radius.)
		Product failure		Replace the product.
4	The switch output generates chattering.	Incorrect wiring	Check the wiring. Check if the brown and blue wires are connected to DC(+) and DC(-) respectively, and if the output line is secure (contact failure).	Correct the connection on the power cord and the plug.
		Incorrect flow setting	(1) Check the set flow value. (2) Check if the hysteresis range is small. (3) Check the delay time setting. (4) Check the digital filter.	(1) Adjust the set flow value. (2) Make the hysteresis wider. (3) (4) Set the function again.
		Pulsation of flow rate	Check that there is no pulsation (fluctuation) of flow rate.	Pulsation may be generated due to the fluctuation of the supply pressure or the characteristics of the compressor/pump used as the pressure source.
		Product failure		Replace the product.

Problem No.	Problem	Problem possible causes	Investigation method	Countermeasures
5	The switch output response is slow.	Incorrect flow setting	(1) Check the set flow value. (2) Check if the hysteresis range is large. (3) Check the delay time setting. (4) Check the digital filter.	(1) Adjust the set flow value. (2) Make the hysteresis narrower. (3) (4) Set the function again.
6	<ul style="list-style-type: none"> •Over current error (Er1, Er2) is displayed. •System error (Er0, 4, 6, 8, 40) is displayed. •"HHH" is displayed. •"LLL" is displayed. 	Excess current was applied to the output (Er1, Er2)	(1) Check if the output current is 80 mA or more. (2) Check if the connected load complies with the specification. Check if the load is short circuited. (3) Check if the relay without surge protection is connected. (4) Check if the wiring is in the same route as (or bundled together with) a high-voltage or power line.	(1)(2) Connect the appropriate load. (3) Use a relay with a surge voltage suppressor or take measures to prevent surge. (4) Separate the wiring from the high-voltage and/or power line.
		Incorrect internal data processing of the product (Er0, 4, 6, 8, 40)	(1) Check if there is noise interference (such as static electricity). Check if there is a noise source nearby. (2) Check if the power supply voltage is in the range 12 to 24 VDC $\pm 10\%$.	(1) Remove the noise and the noise source (or take measures to prevent noise interference), and reset the product (or turn off and then turn back on the power supply). (2) Supply power in the range 12 to 24 VDC $\pm 10\%$.
		Applied flow is higher than the upper limit (HHH)	(1) Check if the flow exceeds the upper limit of the set flow range. (2) Check if foreign matter has entered the piping.	(1) Reset applied flow to a level within the set flow range. (2) Take measures to prevent foreign matter from entering the piping.
		Applied flow is lower than the lower limit (LLL)	(1) Check if the flow exceeds the lower limit of the set flow range. (2) Check if foreign matter has entered the piping.	(1) Reset applied flow to a level within the set flow range. (2) Take measures to prevent foreign matter from entering the piping.
		Product failure		Replace the product.
7	The display is unstable.	Incorrect power supply	Check if the power supply voltage is in the range 12 to 24 VDC $\pm 10\%$.	Supply power in the range 12 to 24 VDC $\pm 10\%$.
		Incorrect wiring	Check the power supply wiring. Check if the brown and blue wires are connected to DC(+) and DC(-) respectively, and if the wiring is secure.	Check and correct the wiring.
		Pulsation of flow rate	Check that there is no pulsation (fluctuation) of flow rate.	If the fluctuation is not acceptable, the number of digits (display sensitivity) can be reduced by changing the display resolution. Digital filter setting may improve the condition.

Problem No.	Problem	Problem possible causes	Investigation method	Countermeasures
8	Applied flow does not match with the displayed value.	Incorrect setting of connection product	Check the setting of connection product. Check that the connected product and the set product are correct.	Select the correct product.
		Incorrect flow range setting	Check the flow range setting. Check if the connected flow sensor and the set flow range are correct.	Select the correct flow range.
9	<ul style="list-style-type: none"> •The display turns OFF. •Part of the display is missing. 	Incorrect power supply	Check if the power supply voltage is in the range 12 to 24 VDC \pm 10%.	Supply power in the range 12 to 24 VDC \pm 10%.
		Incorrect wiring	Check the power supply wiring. Check if the brown and blue wires are connected to DC(+) and DC(-) respectively, and if the wiring is secure.	Check and correct the wiring.
		Power saving mode	Check if power saving mode is selected.	Select the power saving mode again.
		Product failure		Replace the product.
10	Display flashes.	Incorrect wiring	(1) Check the power supply wiring. (2) Check if there is bending stress applied to any part of the lead wire.	(1) Check and correct the wiring. (2) Correct the wiring (bend radius and stress).
11	The display accuracy does not meet the specifications.	Foreign matter entered	Confirmed foreign matter entry or sticking to the piping port.	Use 5 μ m of filter to prevent foreign matter from entering or sticking. Discharge the condensate of the filter periodically.
		Air or liquid leakage	Check if air or liquid are leaking from the piping.	Rework the piping. If the tightening torque is exceeded, the mounting screws, brackets and the product may be damaged.
		Warming up inadequate	Check if the product satisfies the specified accuracy 10 minutes after supplying power.	After energizing, the display and output can drift. For precise flow detection, allow the product to warm up for 10 to 15 minutes.
		Product failure		Replace the product.

Problem No.	Problem	Problem possible causes	Investigation method	Countermeasures
12	Display measurement unit cannot be changed.	Model selection (model selected does not have units selection function)	Check if the product number printed on the product indicates units selection function type.	Unit s selection function is not available for fixed to SI units type. (kPa↔MPa is available) *: The units selection function is not for use in Japan due to a new measurement law. *: Fixed to SI units: kPa, MPa
		Product failure		Replace the product.
13	Buttons do not work.	Key-lock mode is activated	Check if the key-lock function is turned on.	Check the key-lock function.
		Product failure		Replace the product.
14	The operation is unstable. (chattering)	Effect of line pressure fluctuation because hysteresis is too narrow or delay time of the switch is too short	(1) Check the set flow values (hysteresis) (2) Check the delay time.	(1) Adjust the set flow value. (2) Change the response time setting.
		Incorrect wiring/broken lead wire	(1) Check the power supply wiring. (2) Check if there is bending stress applied to any part of the lead wire. (bending radius, tensile force to the lead wire)	(1) Check and correct the wiring. (2) Correct the wiring. (Reduce the tensile force or increase the bending radius.)
		Product failure		Replace the product.

○Troubleshooting (IO-Link communication function)

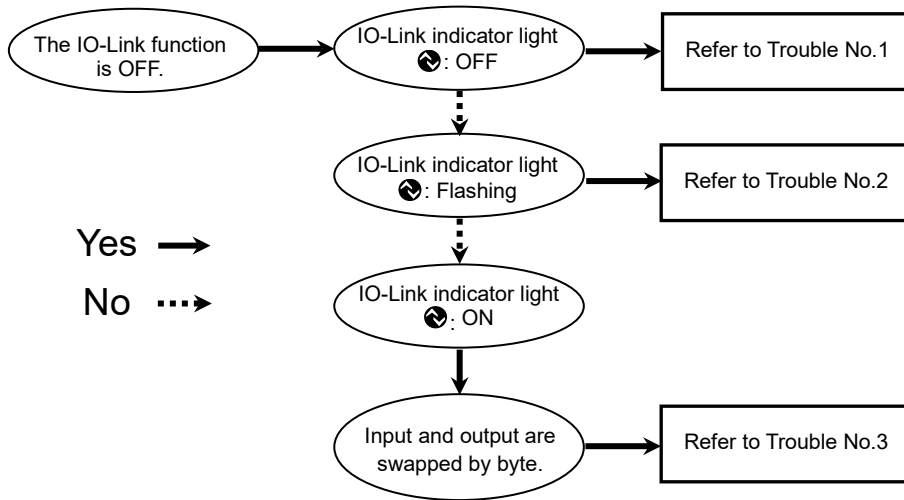

○ Troubleshooting list (IO-Link communication)

Problem No.	Problem	Description	Problem possible causes	Investigation method	Countermeasures
1	IO-Link indicator light 🔴: OFF	—	incorrect wiring	Check the connection of the connector.	Correct the cable wiring.
		—	Power supply error from the IO-Link master	Check the power supply voltage from the IO-Link master.	Supply 18 to 30 VDC to the IO-Link master.
2	IO-Link indicator light 🔴: Flashing	mode ***	Communication is not established. IO-Link wiring failure	Check the connection and cable condition of the IO-Link cable.	Additionally tighten the IO-Link cable. (Replace the cable if it is broken.)
		Er 15 V1.0	IO-Link master and product version are not matched.	Check the IO-Link version of the master and device.	Align the master IO-Link version to the device. *1
		mode Start mode Pre	Communication mode is not transferred to the Operation mode.	Check the setting of the data storage access lock and data storage backup level of the master.	Release the data storage access lock. Or deactivate the setting of the data storage backup level of the master port.
		mode Lock	Backup and restore required during data storage lock	Check the data storage lock.	Release the data storage lock.
3	Data is swapped by byte.	—	Program data assignment is incorrect.	Check that the Endian type on the master upper level communication transmission format is Big Endian type or Little Endian type.	Assign the program data based on the Endian type of the transmission format of the master upper level communication. Or set to the master byte swap setting. (Refer to page 72 for the Endian type of the upper level communication.)

*1: When the product is connected to the master with version "V1.0", error Er15 is generated.



o IO-Link status list

Sub display indication	Details
<i>ds READ</i>	Data storage uploading
<i>ds WRIT</i>	Data storage downloading
<i>bp READ</i>	Block parameter uploading
<i>bp WRIT</i>	Block parameter downloading
<i>ini 000</i>	Receiving restore Factory Setting
<i>rPb 000</i>	Receiving Peak Bottom Clear
<i>rRL 000</i>	Receiving Accumulate reset
<i>rAPP 000</i>	Receiving Application Reset

*: When the operation is completed, the display will return to normal.

○Error indication function

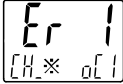
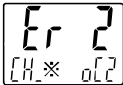
This function is to display error location and content when a problem or error has occurred.

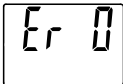
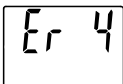
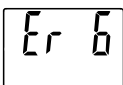
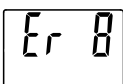
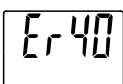
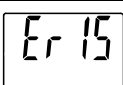
Error	Error displayed	Description	Measures	Error output
Over current error	 *2	The switch output load current is 80 mA or more. ※ indicates channel with error.	Turn the power off and remove the cause of the over current. Then supply the power again.	○
	 *2			
Flow error		Flow exceeding the upper limit of the set flow range is applied.	Reset applied flow to a level within the set flow range. Check the sensor connection and wiring.	Not applicable
		Flow exceeding the lower limit of the set flow range is applied. Sensor is not connected or wired incorrectly.		Not applicable
System error	 *1	Displayed if an internal data error has occurred.	Turn the power off and on again. If the failure cannot be solved, contact SMC.	Not applicable
	 *1			Not applicable
	 *1			○
	 *1			○
	 *1			Not applicable
	 *1			○

*1: The switch output will be OFF when an error is generated.

An error is output when the error output is set (in the product with error output function).

*2: When the set output is an over current error when the error output is set, the switch output is OFF.

If the error cannot be reset after the above measures are taken, or errors other than above are displayed, please contact SMC.

Setting of the error output

In reversed output mode, error [Er0], [Er4] and [Er40] can be detected.

Normal output

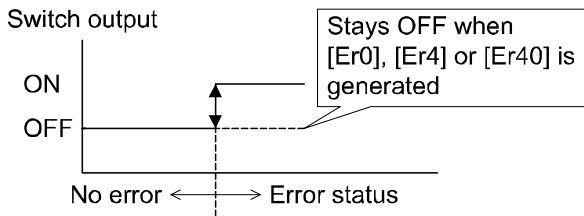

Reversed output

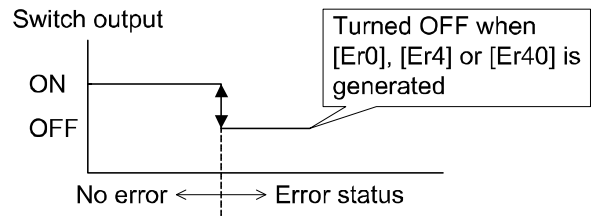

Specifications

Model		PFG20# series												
Applicable flow sensor		PF2A5					PF3W5					PF2D5		
		10	50	11	21	51	04	20	40	11	25	04	20	40
Rated flow range		1 to 10 L/min	5 to 50 L/min	10 to 100 L/min	20 to 200 L/min	50 to 500 L/min	0.5 to 4 L/min	2 to 16 L/min	5 to 40 L/min	10 to 100 L/min	50 to 250 L/min	0.4 to 4 L/min	1.8 to 20 L/min	4 to 40 L/min
Instantaneous flow display/ Set flow range		0 to 11 L/min	0 to 55 L/min	0 to 110 L/min	0 to 220 L/min	0 to 550 L/min	0.35 to 4.50 L/min (Displays 0.00 when the value is below 0.35 L/min)	1.7 to 18.0 L/min (Displays 0.0 when the value is below 1.7 L/min)	3.5 to 45.0 L/min (Displays 0.0 when the value is below 3.5 L/min)	7 to 112 L/min (Displays 0 when the value is below 7 L/min)	20 to 280 L/min (Displays 0 when the value is below 20 L/min)	0.25 to 4.50 L/min (Displays 0.00 when the value is below 0.25 L/min)	1.3 to 21.0 L/min (Displays 0.0 when the value is below 1.3 L/min)	2.5 to 45.0 L/min (Displays 0.0 when the value is below 2.5 L/min)
Instantaneous flow display/ Min. setting unit		0.1 L/min	0.5 L/min	1 L/min	2 L/min	5 L/min	0.05 L/min	0.1 L/min	0.5 L/min	1 L/min	2 L/min	0.05 L/min	0.1 L/min	0.5 L/min
Accumulated flow display/ Set flow range		0 to 999,999,999 L				0 to 9,999,999.99 x 10 ³ L	0 to 99,999,999.9 L	0 to 999,999,999 L				0 to 99,999,999.9 L	0 to 999,999,999 L	
Accumulated flow display/ Min. setting unit		1 L				10 L	0.1 L	1 L				0.1 L	1 L	
Accumulated pulse flow rate conversion value		0.1 L/pulse	0.5 L/pulse	1 L/pulse	2 L/pulse	5 L/pulse	0.05 L	0.1 L	0.5 L	1 L	2 L	0.05 L	0.1 L	0.5 L
Unit		L/min, cfm (According to the range setting)					L/min, gal/min (According to the range setting)					L/min, gal/min (According to the range setting)		
Electric spec.	Power supply voltage Used as switch output device	12 to 24 VDC±10%, and ripple (p-p) 10% at max.												
	Power supply voltage Used as IO-Link device	18 to 30 VDC, including ripple (p-p) 10% *1												
	Current consumption	55 mA or less												
	Protection	Polarity protection												
	Power supply voltage for sensor *1	Power supply voltage: -1.5 V												
Power supply current for sensor *2	Max.110 mA (However, the total power supply current of 4 input is 440 mA or less maximum) The total power supply current when used as an IO-Link device is 200 mA or less maximum													
Accuracy	Display accuracy (Linearity)	±5.0%F.S. Max. *4												
	Repeatability	±3.0%F.S. *4												
	Temperature characteristics	±0.5%F.S. (25 °C standard)												

Model		PFG20# series											
Applicable flow sensor		PF2A5					PF3W5					PF2D5	
		10	50	11	21	51	04	20	40	11	25	04	20
Switch output (During SIO mode)	Output type	NPN or PNP open collector output5 output											
	Output mode	Hysteresis, window comparator, accumulated output, accumulated pulse output, error output, output OFF											
	Switch operation	Normal output, reversed output											
	Maximum load current	80 mA											
	Maximum applied voltage (NPN output)	30 VDC											
	Internal voltage drop (Residual voltage)	1.5 V or less (Load current 80 mA)											
	Delay time *3	5 ms or less, 0 to variable from 60 s/0.01 s increments											
	Response time *4	3 ms or less											
	Hysteresis	Variable from zero *5											
	Protection	Over current protection											
Sensor input	Input type	Voltage input: DC1 to 5 V (Input impedance: 1 MΩ)											
	Number of inputs	4 input											
	Connection method	e-CON											
	Protection	Over voltage protection (up to a voltage of 26.4 VDC)											
Display	Display type	LCD											
	Number of displays	3 (1 main display and 2 sub displays)											
	Display colour	Main display: Red/Green, Sub display: Orange											
	Number of display digits	Main display: 4 digits 7segment Sub display (left): 4 digits (partially 11-segments, 7-segments for other) Sub display (right): 5 digits (partially 11-segments, 7-segments for other)											
	Operation light	LED is ON when switch output is ON (OUT1, OUT2: Orange)											
Digital filter *6		Variable from 0 to 30 s/0.01 s increments											
Environment	Enclosure	IP65 (front side only when the panel is mounted), IP40 for others											
	Withstand voltage	1000 VAC for 1 minute between terminals and housing											
	Insulation resistance	50 MΩ or more between terminals and housing (with 500 VDC megger)											
	Ambient temperature range	Operation: 0 to 50 °C, Storage: -10 to 60 °C (No condensation)											
	Operating humidity range	Operation and storage: 35 to 85%RH (No condensation)											
Standard		CE/UKCA marked											
Weight	Body	51 g (power supply and output cables are excluded)											
	Power supply/output cable	60 g											
	e-CON connector (1 pc.)	2 g											

*1: Check the range of the power supply voltage of the sensor to connect.

*2: The product will be damaged when the DC (+) and DC (-) of the sensor input connector are short-circuited.

*3: Value without digital filter (at 0 ms).

*4: It is the value when combined with an applicable flow sensor.

*5: If the applied flow fluctuates around the set value, the hysteresis must be set to a value more than the amount of fluctuation or chattering will occur.

*6: The response time indicates when the set value is 90% in relation to the step input.

*7: Any products with tiny scratches, smears, or variations in the display colour or brightness, which does not affect the performance of the product, are verified as conforming products.

○Cable specification

Conductor area		0.15 mm ² (AWG26)
Insulator	Outside diameter	0.9 mm
Sheath	Finished outside diameter	φ 4.8

○Communication specification (During IO-Link mode)

IO-Link type	Device
IO-Link version	V1.1
Communication speed	COM2 (38.4 kbps)
Configuration file	IODD file *8
Min. cycle time	4.8 ms
Process data length	Input Data: 10 byte, Output Data: 0 byte
On request data communication	Available
Data storage function	Available
Event function	Available
Vendor ID	131 (0x0083)
Device ID	655 (0x00028F)

*8: The configuration file can be downloaded from the SMC website, <https://www.smcworld.com>

■Dimensions

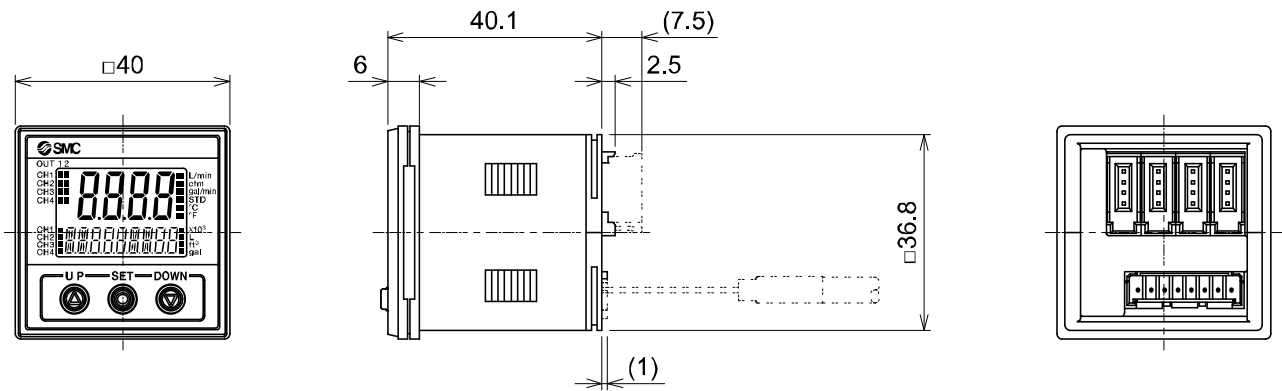

○Power supply/output cable

- ZS-26-L

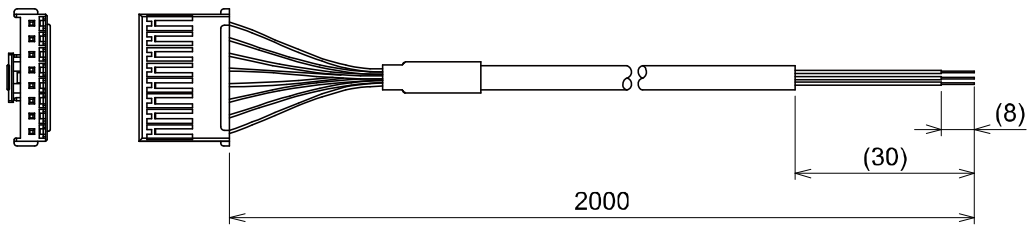

Revision history

A: Contents revised in several places.

[March 2023]

B: Contents revised in several places.

[May 2024]

SMC Corporation

Tel: + 81 3 5207 8249 Fax: +81 3 5298 5362

URL <https://www.smcworld.com>