



# Operation Manual

PRODUCT NAME

Flow Controller for Air

MODEL / Series / Product Number

*PFCA7##*

**SMC Corporation**

# Contents

Safety Instructions	3
Model Indication and How to Order	11
Names and Functions of Product Parts	13
Definition and Terminology	16
Mounting and Installation	18
Installation	18
Piping	18
Wiring Method	19
Outline of Settings [Measurement Mode]	21
[Function Selection Mode] to Change Settings	22
Factory default setting	23
F0 System: System settings	24
F1 Switch1: OUT1 settings	28
F10 Measure: Measurement settings	32
F22 Analog out: Analogue output settings	33
F30 Accumulate: Accumulated flow (rate) settings	35
F80 Display: Display settings	37
F81 PIN code: PIN code settings	41
F91 Device info: Checking device information	42
F96 Input check: Checking input signal	43
F98 Output check: Checking output signal	44
F99 Reset setting: Resetting to factory default settings	47
[Control Selection Setting Mode] to Change the Flow Rate Control Command Method	48
[Key-Lock Setting Mode] to Limit Button Operations	51
Other Settings	53
Maintenance	54
IO-Link Specifications	54
IO-Link function overview	54
Communication specifications	54
Process data	55
IO-Link parameter settings	59
Troubleshooting	66
Warning/Error display	70
Specifications	74
Characteristics data	77
Dimensions	79



# Safety Instructions

These safety instructions are intended to prevent hazardous situations and/or equipment damage. These instructions indicate the level of potential hazard with the labels of “**Caution**,” “**Warning**” or “**Danger**.” They are all important notes for safety and must be followed in addition to International Standards (ISO/IEC)<sup>\*1</sup>, and other safety regulations.

\*1) ISO 4414: Pneumatic fluid power - General rules and safety requirements for systems and their components  
ISO 4413: Hydraulic fluid power - General rules and safety requirements for systems and their components  
IEC 60204-1: Safety of machinery - Electrical equipment of machines - Part 1: General requirements  
ISO 10218-1: Robots and robotic devices - Safety requirements for industrial robots - Part 1: Robots  
etc.



## **Danger**

**Danger** indicates a hazard with a high level of risk which, if not avoided, will result in death or serious injury.



## **Warning**

**Warning** indicates a hazard with a medium level of risk which, if not avoided, could result in death or serious injury.



## **Caution**

**Caution** indicates a hazard with a low level of risk which, if not avoided, could result in minor or moderate injury.



## **Warning**

### **1. The compatibility of the product is the responsibility of the person who designs the equipment or decides its specifications.**

Since the product specified here is used under various operating conditions, its compatibility with specific equipment must be decided by the person who designs the equipment or decides its specifications based on necessary analysis and test results. The expected performance and safety assurance of the equipment will be the responsibility of the person who has determined its compatibility with the product. This person should also continuously review all specifications of the product referring to its latest catalog information, with a view to giving due consideration to any possibility of equipment failure when configuring the equipment.

### **2. Only personnel with appropriate training should operate machinery and equipment.**

The product specified here may become unsafe if handled incorrectly. The assembly, operation and maintenance of machines or equipment including our products must be performed by an operator who is appropriately trained and experienced.

### **3. Do not service or attempt to remove product and machinery/equipment until safety is confirmed.**

1. The inspection and maintenance of machinery/equipment should only be performed after measures to prevent falling or runaway of the driven objects have been confirmed.
2. When the product is to be removed, confirm that the safety measures as mentioned above are implemented and the power from any appropriate source is cut, and read and understand the specific product precautions of all relevant products carefully.
3. Before machinery/equipment is restarted, take measures to prevent unexpected operation and malfunction.

### **4. Our products cannot be used beyond their specifications. Our products are not developed, designed, and manufactured to be used under the following conditions or environments. Use under such conditions or environments is not covered.**

1. Conditions and environments outside of the given specifications, or use outdoors or in a place exposed to direct sunlight.
2. Use for nuclear power, railways, aviation, space equipment, ships, vehicles, military application, equipment affecting human life, body, and property, fuel equipment, entertainment equipment, emergency shut-off circuits, press clutches, brake circuits, safety equipment, etc., and use for applications that do not conform to standard specifications such as catalogs and operation manuals.
3. Use for interlock circuits, except for use with double interlock such as installing a mechanical protection function in case of failure. Please periodically inspect the product to confirm that the product is operating properly.



# Safety Instructions

## Caution

**We develop, design, and manufacture our products to be used for automatic control equipment, and provide them for peaceful use in manufacturing industries.**

**Use in non-manufacturing industries is not covered.**

Products we manufacture and sell cannot be used for the purpose of transactions or certification specified in the Measurement Act.

The new Measurement Act prohibits use of any unit other than SI units in Japan.

## Limited warranty and Disclaimer/Compliance Requirements

The product used is subject to the following “Limited warranty and Disclaimer” and “Compliance Requirements”. Read and accept them before using the product.

### Limited warranty and Disclaimer

1. The warranty period of the product is 1 year in service or 1.5 years after the product is delivered, whichever is first.\*2)  
Also, the product may have specified durability, running distance or replacement parts. Please consult your nearest sales branch.
2. For any failure or damage reported within the warranty period which is clearly our responsibility, a replacement product or necessary parts will be provided.  
This limited warranty applies only to our product independently, and not to any other damage incurred due to the failure of the product.
3. Prior to using SMC products, please read and understand the warranty terms and disclaimers noted in the specified catalog for the particular products.

**\*2) Vacuum pads are excluded from this 1 year warranty.**

A vacuum pad is a consumable part, so it is warranted for a year after it is delivered.

Also, even within the warranty period, the wear of a product due to the use of the vacuum pad or failure due to the deterioration of rubber material are not covered by the limited warranty

### Compliance Requirements

1. The use of SMC products with production equipment for the manufacture of weapons of mass destruction (WMD) or any other weapon is strictly prohibited.
2. The exports of SMC products or technology from one country to another are governed by the relevant security laws and regulations of the countries involved in the transaction. Prior to the shipment of a SMC product to another country, assure that all local rules governing that export are known and followed.

## ■ About operators

- (1) This Operation Manual is intended for those who have knowledge and experience of machinery using pneumatic equipment, and have sufficient knowledge and experience of assembly, operation and maintenance of such equipment.  
Only those persons are allowed to perform assembly, operation and maintenance.
- (2) Read and understand this Operation Manual carefully before assembling, operating or providing maintenance to the product.

## ■ Safety Instructions

### Warning

- Do not disassemble, modify (including replacing the circuit board) or repair.  
Otherwise, an injury or failure can result.
- Do not use the product outside of the specifications.  
Do not use the product with flammable or harmful gases or fluids.  
Fire, malfunction, or damage to the product may result.  
Check the specifications before use.
- Do not use in an environment where flammable, explosive or corrosive gases are present.  
Fire or an explosion may result.  
The product is not designed to be explosion proof.
- Do not use the product with flammable fluid.  
Fire or an explosion may result.
- Do not use the product in a place where static electricity is a problem.  
Otherwise failure or malfunction of the system can result.
- If using the product in an interlocking circuit:
  - Provide a double interlocking system, for example a mechanical system.
  - Check the product for proper operation.Otherwise malfunction can result, causing an accident.
- The following instructions must be followed during maintenance:
  - Turn off the power supply.
  - Stop the air supply, exhaust the residual pressure in the piping and verify that the air is released before performing maintenance work.Otherwise an injury can result.

## Caution

- Do not touch the terminals and connectors while the power is on.  
Otherwise electric shock, malfunction and damage to the product can result.
- After maintenance is complete, perform appropriate functional inspections and a leak test.  
Stop operation if the equipment does not function properly or there is leakage of fluid.  
When leakage occurs from parts other than the piping, the product might be faulty.  
Cut off the power supply and stop the fluid supply.  
Do not apply fluid if the system is leaking.  
Otherwise, an unexpected malfunction may occur and safety cannot be assured.

### ■ Precautions for Handling

- Follow the instructions given below for the selection and handling of the product.
  - The instructions on selection (installation, wiring, environment, adjustment, operation, maintenance, etc.) described below must be followed.
    - \*Product specifications
      - This product is not suitable for applications to shut off the flow rate completely.  
If it is necessary to shut off the flow rate completely, install a stop valve, etc. separately.
      - Use within the specified voltage.  
Otherwise failure or malfunction can result.
      - For details of the compressed air quality, refer to JIS B 8392-1 1.6.2.
      - Use within the specified flow rate and pressure range.
      - Reserve a space for maintenance.  
Design the system to allow the required space for maintenance.

●Product Handling

\*Mounting

- If a commercially available switching power supply is used, be sure to ground the frame ground (FG) terminal.
- Do not drop, hit or apply excessive shock to the product.  
Otherwise damage to the internal components may result, causing malfunction.
- Do not pull the lead wire forcefully, or lift the product by the lead wire.  
The product will be damaged, leading to failure and malfunction.
- The product should be flushed out by air blow to remove any dust left in the piping before connecting the piping to the product.  
Otherwise it can cause damage or malfunction.
- Refer to the flow direction of the fluid indicated on the product label during installation and piping.
- Do not mount the product with the display facing downward.
- Do not insert metal wires or other foreign matter into the piping ports.  
This can damage the sensor causing failure or malfunction.
- Never mount the product in a place that will be used as a foothold during piping.  
The product may be damaged if excessive force is applied by stepping or climbing onto it.
- If there is a risk of foreign matter entering the fluid, install a filter or mist separator on the IN side (entry side) to avoid failure and malfunction.  
Otherwise it can cause damage or malfunction. The product will be unable to measure accurately or control the flow rate.  
Refer to the figure below for the recommended pneumatic circuit.
- If the fluid flow on the IN side (entry side) of the product is unstable, correct measurement and flow rate control will not be possible.  
If a valve is used on the IN side (entry side) of the product, the flow may be disturbed due to the change of the effective area.
- Do not install a restrictor immediately on the product OUT side (outlet).  
Otherwise, the flow control action may be unstable.

Recommended pneumatic circuit example

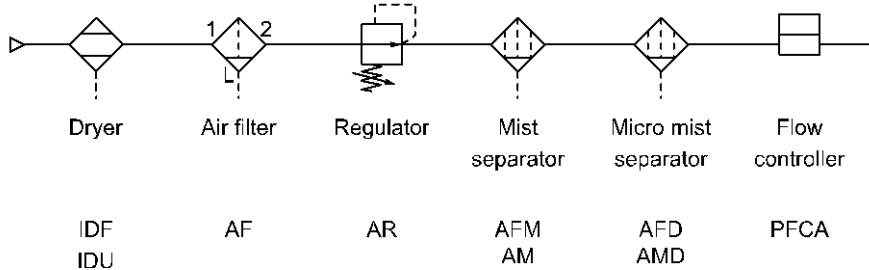

\*Wiring (Including connecting/disconnecting of the connectors)

•Do not pull hard on the lead wire.

Especially never lift the product equipped with fitting and piping by holding the lead wires.

Otherwise damage to the internal components may result, causing malfunction or connectors dropping off.

•Avoid repeatedly bending, stretching or applying a heavy object to the lead wire.

Repetitive bending stress or tensile stress can cause the sheath of the wire to peel off, or breakage of the wire.

If the lead wire can move, fix it near the product.

The recommended bend radius of the lead wire is 6 times the outside diameter of the sheath, or 33 times the outside diameter of the insulation material, whichever is larger.

Replace the damaged lead wire with a new one.

•Wire correctly.

Incorrect wiring may cause malfunction or damage to the product.

•Do not perform wiring while the power is on.

Otherwise damage to the internal components may result, causing malfunction.

•Do not route wires and cables together with power or high voltage cables.

Route the wires of the product separately from power or high voltage cables to prevent noise and surge of signal lines from entering the product.

•Confirm correct insulation of wiring.

Poor insulation (interference with other circuits, poor insulation between terminals, etc.) can apply excessive voltage or current to the product causing damage.

•Keep wiring as short as possible to prevent interference from noise and surge voltage.

Do not use a cable longer than 20 m.

Wire the DC(-) line(blue) as close as possible to the power supply.

•When the analogue output is used, install a noise filter (line noise filter, ferrite element, etc.) between the switch-mode power supply and the product.



#### \*Operating environment

- Do not use in an atmosphere containing corrosive gases, chemicals, sea water, water, water steam, or where there is direct contact with any of these.  
These may cause failure or malfunction.
- Do not use the product in a place where the product could be splashed by oil or chemicals.  
If the product is to be used in an environment containing oils or chemicals such as coolant or cleaning solvent, even for a short time, it may be adversely affected (damage, malfunction, or hardening of the lead wires).
- Do not use in an area where electrical surges are generated.  
When there are machines or equipment that generate large surges near the product (magnetic type lifter, high frequency inductive furnace, motor, etc.), this can result in deterioration and damage of the internal circuit elements. Take protective measures to isolate the surge sources and prevent the lines from coming into close contact.
- Do not use a load which generates a surge voltage.  
When a surge-generating load such as a relay or solenoid is driven directly, use a load with a built-in surge suppressor.
- The product is CE/UKCA marked but is not immune to lightning strikes. Take measures against lightning strikes in the system.
- Mount the product in a location that is not affected by vibration or impact.  
Otherwise, a failure or malfunction may be caused.
- Do not use the product in the presence of a magnetic field.  
Otherwise, a malfunction of the product may be caused.
- Do not let foreign matter, such as wire debris, get inside the product.  
Otherwise, a failure or malfunction may be caused.
- Do not use the product in an environment that is exposed to temperature cycles.  
Temperature cycles other than ordinary changes in temperature can adversely affect the internal components of the product.
- Do not expose the product to direct sunlight.  
If using in a location directly exposed to sunlight, shade the product from the sunlight.  
Otherwise, a malfunction may be caused.
- Keep within the specified temperature range.  
Operation under low temperature may lead to damage or operation failure due to frozen moisture in the air. Protection against freezing is necessary.  
The installation of an air dryer is recommended for elimination of drainage and water.  
Avoid abrupt temperature changes even within the specified temperature range.
- Do not operate close to a heat source, or in a location exposed to radiant heat.  
Otherwise malfunction can result.
- Do not install the products close to each other or do not close the vent hole when installing the product.  
Otherwise, the temperature of the product may rise, resulting in a failure or malfunction.

#### \*Adjustment and operation

- Connect the load before turning the power supply on.
- Do not short-circuit the load.
- Confirm that the fluid is flowing in the pipe when controlling the flow rate.  
If there is no supply pressure, a current beyond the product specifications may flow in the event of an error in control action.
- If the controlled flow rate does not continuously reach the commanded flow rate for at least 5 seconds, it will result in a control error and the flow control will stop.
- Do not touch the LCD during operation.  
The display can vary due to static electricity.
- When the product is not energized, the valve is fully closed (normally closed (N.C.)).
- Do not supply a pressure that is higher than that in the IN side to the OUT side.  
Otherwise, the control valve will open, causing the fluid to flow backward.

#### \*Maintenance

- Perform regular maintenance and inspections.  
There is a risk of unexpected failure of components due to the malfunction of equipment and machinery.
- Before performing maintenance, turn off the power supply, stop the air supply, exhaust the residual compressed air in the piping, and verify the release of air.  
Otherwise, unintended malfunction of system components can result.
- Remove the condensate periodically.  
If condensate enters the OUT side, it can cause operating failure of pneumatic equipment.
- Do not use solvents such as benzene, thinner, etc. to clean the product.  
This may damage the surface of the body or erase the markings on the body.  
Use a soft cloth to remove stains.  
For heavy stains, use a damp cloth soaked with diluted neutral detergent and fully squeezed, then wipe up the stains again with a dry cloth.

# Model Indication and How to Order

PFCA7  -  -   -

Rated control flow range

Model	Description
10	0.1 to 10 L/min
25	0.2 to 25 L/min
50	0.5 to 50 L/min
11	1 to 100 L/min

Port size

Model	Port size	Rated control flow range			
		10	25	50	11
01	Rc1/8	●	●	●	-
N1	NPT1/8	●	●	●	-
F1	G1/8	●	●	●	-
02	Rc1/4	-	-	-	●
N2	NPT1/4	-	-	-	●
F2	G1/4	-	-	-	●
C4	φ4	●	-	-	-
C6	φ6	●	●	●	●
C8	φ8	-	●	●	●
N7	φ 1/4"	-	●	●	●

Input/Output specifications

Model	IN	OUT1	OUT2
1	Analogue input (1 to 5 V)	IO-Link /NPN /PNP	Analogue output (1 to 5 V ⇔ 0 to 10 V) <sup>*1</sup>
2	Analogue input (4 to 20 mA)	IO-Link /NPN /PNP	Analogue output (4 to 20 mA)

\*1: 1 to 5 V or 0 to 10 V can be selected by pressing the buttons.  
The default setting is 1 to 5 V.

Operation Manual and Calibration Certificate<sup>\*5</sup>

Model	Description	
	Operation Manual	Calibration Certificate
Nil	●	-
Y	-	-
K	●	●
T	-	●

\*5: Written in both Japanese and English.

Option 2

Model	Description
Nil	None
R	Bracket (Mounting position: Side)
S	Bracket (Mounting position: Flow path)

Units specification

Model	Description
Nil	With unit conversion function <sup>*3</sup>
M	SI unit fixed <sup>*4</sup>

\*3: This product will not be sold for use in Japan in accordance with the new measurement law (SI unit in Japan).  
Convertible unit, Instantaneous flow: L/min ⇔ cfm  
Accumulated flow: L ⇔ ft<sup>3</sup>

\*4: Fixed unit, instantaneous flow: L/min.  
Accumulated flow: L

Option 2

Model	Description
Nil	With lead wire with M12 connector (3 m/5-core)
N	Without lead with connector
Q	With lead wire with M12-M12 connector (3 m/5-core) <sup>*2</sup>

\*2: One end has an M12 (socket) connector and the other end has an M12 (plug) connector.

### Option 1

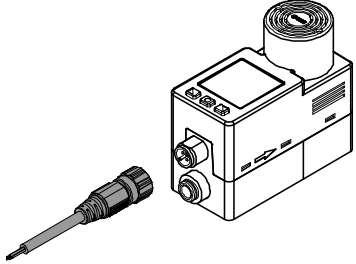
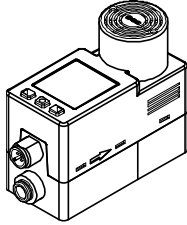
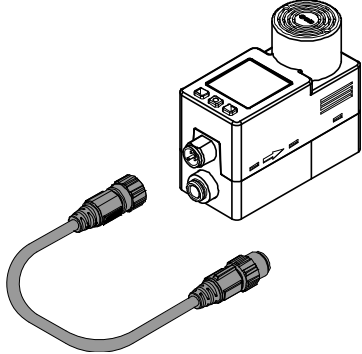
Nil	N	Q
With lead wire with M12 connector (3 m) <b>ZS-53-A</b> 	None 	With lead wire with M12-M12 connector <b>ZS-53-D</b> 

### Option 2

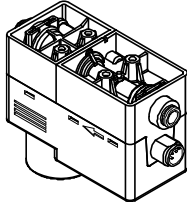
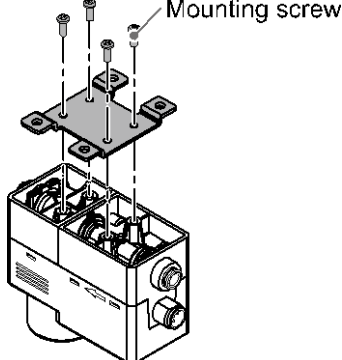
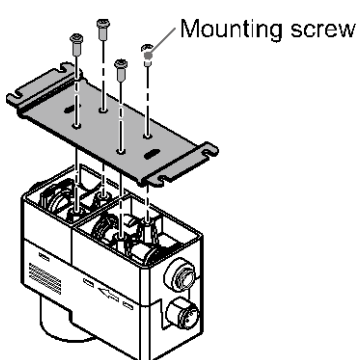
Nil	R	S
None 	With bracket (Mounting position: Side) <b>ZS-40-L</b> 	With bracket (Mounting position: Flow path) <b>ZS-53-G</b> 

### Accessories/part numbers

If an accessory is required, order using the following part numbers.

Part number	Options	Remarks
ZS-53-A	Lead wire with M12 connector	Length: 3 m, 5-core
ZS-53-D	Lead wire with M12 connector	Length: 3 m, 5-core, M12 (socket)-M12 (plug)
ZS-40-L	Bracket	Mounting position: Side
ZS-53-G	Bracket	Mounting position: Flow path

# Names and Functions of Product Parts

## Body

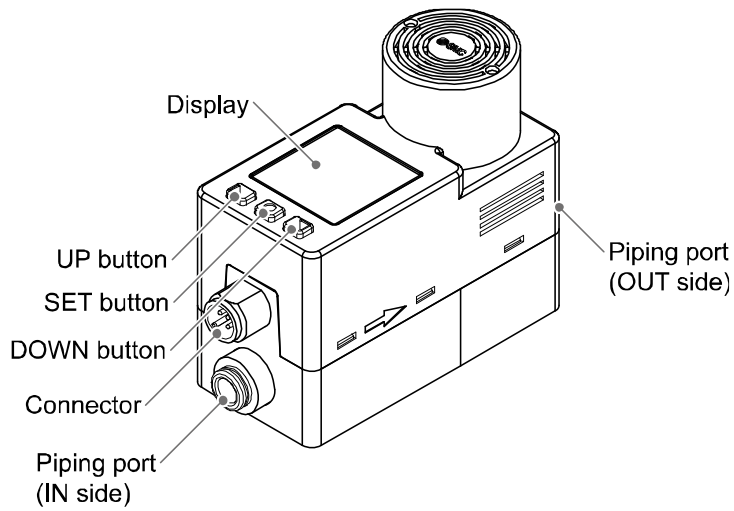

Connector pin numbers  
(on the product)

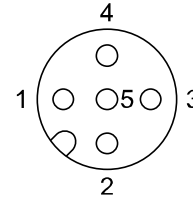



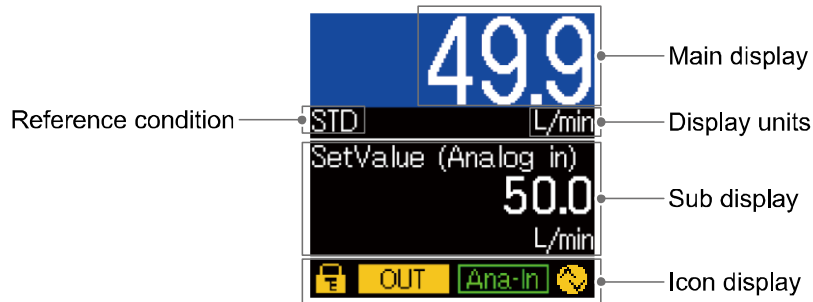

1	DC(+)
2	OUT2 (Analogue output)
3	DC(-)
4	OUT1 (C/Q)
5	IN (Analogue input)

Description	Function
Display	Refer to the figure below.
Piping port	For piping connections. IN represents "inlet" and OUT represents "outlet".
Connector	Lead wire with M12 connection.
UP button DOWN button	Use this button to select the mode and the display shown on the Sub display, or increase or decrease the numerical value. The assignment of the UP and DOWN buttons changes depending on the display rotation angle. For details, refer to "Display rotation angle setting" on page 39.
SET button	Press this button to change the mode and to set a value.













## Display



Description	Function
Main display	Displays the flow rate value and the error code.
Sub display	Displays the commanded flow rate, peak/bottom value, accumulated flow rate value, switch output/communication mode, and line names.
Reference condition	Indicates the reference condition currently selected.
Display units	Indicates the units currently selected.
Icon display	Displays the function status. Refer to the next page for details.

Icon	Name	Description
	Key-lock	Turns ON when the buttons are locked.
	OUT status	The LED is ON when the output is ON.
	Analogue input status	Red: Analogue input warning (less than -5%) Green: Analogue input normal Yellow: Analogue input warning (above 110%)
	IO-Link status	Yellow: Communicating with IO-Link White: Connecting to IO-Link (including communication disruption) Light is OFF: Not connected with IO-Link

o IO-Link status and displayed content

Communication with master	IO-Link status	Status		Displayed content	Content	
Yes		IO-Link mode	Normal	Operate		Normal communication status (Output PD disabled)
						Normal communication status (Output PD enabled)
	Start up			At the start of communication		
	Preoperate					
	Version does not match			IO-Link version does not match with master		
No		Error	Communication shut-off		Normal communication was not received (for more than 1 second).	
						
						
						
	Light is OFF		SIO mode			General switch output

o IO-Link communication indication

Contents indicated	Content
DS read	Data storage uploading
DS write	Data storage downloading
BP read	Block parameter uploading
BP write	Block parameter downloading
Factory reset	Receiving Restore Factory Reset
Zero clear	Receiving Zero Clear
Accumurate reset	Receiving Accumulate Reset
Peak/Bottom clear	Receiving Peak Bottom Reset
Application reset	Receiving Application Reset

\*: When the operation is completed, the display will return to normal.

## ■ Definition and Terminology

	Term	Definition
A	Accumulated flow	The total amount of fluid that has passed through the device. If an instantaneous flow of 10 L/min lasts for 5 minutes, the accumulated flow will be $10 \times 5 = 50$ L.
	Accumulated pulse output	A type of output where a pulse is generated every time a predefined accumulated flow passes. It is possible to calculate the total accumulated flow by counting the pulses.
	Accumulated value hold function	A function to store the cumulative flow value in the product's internal memory at certain time intervals. Reads the memory data when power is supplied. Accumulation of data begins with the value read at the moment power is supplied. The time interval for storing to memory can be selected from 2 or 5 minutes.
	Analogue input	Controls the flow rate that is proportional to the input signal. For analogue input of 1 to 5 V, the flow rate is controlled according to the input signal between 1 to 5 V. The same applies to the analogue input of 4 to 20 mA.
	Analogue output	Outputs a value proportional to the flow rate. When the analogue output is in the range of 1 to 5 V, it will vary between 1 to 5 V according to the rate of flow. The same for analogue output of 4 to 20 mA.
C	Commanded flow rate	Specified value for the controlled flow rate. In IO-Link mode: output process data; at local setting: set local flow rate value; at analogue input: analogue input value.
	Control accuracy	An error between the flow rate corresponding to the commanded flow rate and the flow rate controlled by the product.
	Control error	The condition in which the flow rate has not reached the commanded value continuously for at least 5 seconds.
D	Delay time	Setting time from when the flow rate reaches the set value to when the ON-OFF output actually operates. Setting a delay time can prevent the output from chattering.
	Displayable range	Range which can be displayed.
E	Error output	Turns the switch output to OFF when an error is displayed. Refer to "Error display" on page 72 for details of error codes.
F	F.S.	Full scale in the case of flow rate, meaning the max. flow rate in the rated control flow range. Full span in the case of the analogue output, meaning the variation width of analogue output from zero flow rate to the max. rated control flow. For example, when the analogue output is 1 to 5 V, $F.S. = 5 \text{ V} - 1 \text{ V} = 4 \text{ V}$ . (Reference: $1\%F.S. = 4 \text{ V} \times 1\% = 0.04 \text{ V}$ )
I	Instantaneous flow	The flow passing per unit of time. If it is 10 L/min, there is a flow of 10 L passing through the device in 1 minute.
	Internal voltage drop	The voltage drop across the product (and therefore not applied to the load), when the switch output is ON. The voltage drop varies depending on the flowing load current, and ideally it should be 0 V.
K	Key-lock function	Function that prevents changes to the settings (disables button operation).
M	Min. operational differential pressure	The min. differential pressure value (pressure difference between primary and secondary sides) required for the product to operate normally.
N	Normal condition	The flow which is converted into the volume at 0 °C and 1 atm (atmospheric pressure). [NOR] indicates that the product is in normal condition.



	Term	Definition
O	Operating humidity range	Humidity range in which the product operates normally.
	Operating pressure range	Pressure range in which the product operates normally.
	Operating temperature range	Ambient temperature range in which the product operates normally.
P	Pressure characteristics	Indicates the change in the control accuracy due to changes in the fluid pressure.
	Proof pressure	Pressure limit that if exceeded will result in mechanical and/or electrical damage to the product.
R	Rated control flow range	Flow range in which the control accuracy is satisfied.
	Repeatability	Reproducibility of the controlled flow rate or analogue output value, when the measured quantity is repeatedly increased and decreased.
S	Set controlled flow rate range	Range in which the commanded flow rate can be input.
	Settling time	Time for the flow rate to reach within $\pm 3\%$ F.S. of the commanded flow rate value in relation to the input signal. For this product, the time when the step signal of 1 $\rightarrow$ 100% is input is stated in the specifications. (Temperature: 25 °C; pressure: reference operating pressure)
	Standard condition	The flow which is converted to the volume at 20 °C and 1 atm (atmospheric pressure). [STD] indicates that the product is in standard condition.
	Switch output	Output type that has only 2 conditions, ON or OFF. In the ON condition an indicator LED will show, and any connected load will be powered. In the OFF condition, there will be no indicator LED and no power supplied to the load. An output showing such behavior is called switch output.
T	Temperature characteristics	Indicates the change in the control accuracy due to changes in the ambient temperature.
U	Units selection function	A function to select the display units other than the international units (SI units) specified in the new measurement law in Japan. The product for use in Japan is not equipped with this function.
W	Wetted part	A part that comes into physical contact with the fluid.
Z	Zero-clear	Function to adjust the flow rate display to zero.

## Mounting and Installation

### ■ Installation

- Mount the product so that the fluid flows in the direction indicated by the arrow on the side of the body.

### Bracket mounting

- Mount the bracket using the mounting screws supplied.
- The tightening torque of the bracket mounting screws must be  $0.63 \pm 10\%$  N•m.
- When the product is mounted using a bracket, use M3 screws (4 pcs.) or equivalent.
- For the dimensions of the bracket, refer to page 81.

### ■ Piping

#### For the metal piping attachments

- Ensure that the metal piping attachments are tightened to the required torque (refer to the table below).
- If the tightening torque is exceeded, the product can be broken. If the tightening torque is insufficient, the fittings may become loose.
- When connecting piping to the product, a spanner should be used on the metal piping attachment only. Using a spanner on other parts may damage the product. Specifically, make sure that the spanner does not damage the connector.
- Avoid any sealing tape from entering inside the piping.
- Ensure that there is no leakage from loose piping.

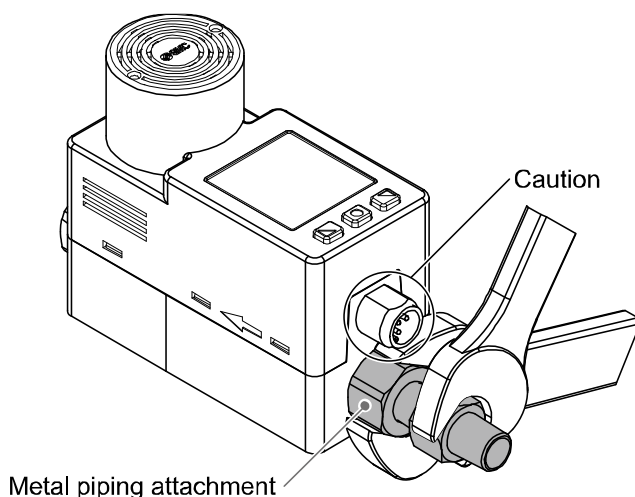

Nominal thread size	Required torque
Rc(NPT)1/8	7 to 9 N•m
Rc(NPT)1/4	12 to 14 N•m

Nominal thread size	Width across flats of attachment
Rc(NPT)1/8 Rc(NPT)1/4 G1/8	17 mm
G1/4	21 mm

#### For one-touch fittings

- Insert the tube until it bottoms out, to ensure it cannot be pulled out.
- Insertion with excessive force can cause damage.
- Ensure that there is no leakage after piping.

## ■ Wiring Method

### Connections

- Connections should only be made with the power supply turned off.
- Use a separate route for the product wiring and any power or high voltage wiring. If wires and cables are routed together with power or high voltage cables, malfunction may result due to noise.
- If a commercially available switching power supply is used, be sure to ground the frame ground (FG) terminal. If a commercially available switch-mode power supply is connected for use, switching noise will be superimposed and it will not be able to meet the product specifications. In that case, insert a noise filter such as a line noise filter/ferrite between the switching power supplies or change the switching power supply to a series power supply.

### Connector pin numbers (lead wire) (ZS-53-A)

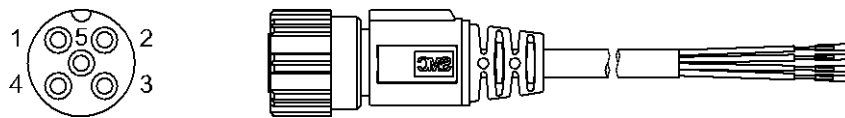

When used as a switch output device

Pin number	Wire colour	Name	Description
1	Brown	DC(+)	24 VDC
2	White	OUT2	Analogue output
3	Blue	DC(-)	0 V
4	Black	OUT1	Switch output
5	Grey	IN	Analogue input

When used as an IO-Link device

Pin number	Wire colour	Name	Description
1	Brown	DC(+)	24 VDC
2	White	NC	Not connected *1
3	Blue	DC(-)	0 V
4	Black	C/Q	Communication data (IO-Link)
5	Grey	NC	Not connected *2

\*1: The analogue output function operates in the same way as when used as a switch output device. Therefore, do not connect to the IO-Link master.

\*2: The analogue input function operates in the same way as when used as a switch output device. Therefore, do not connect to the IO-Link master.

## Internal circuit and wiring examples

NPN type

Maximum applied voltage: 30 V

Maximum load current: 80 mA

Internal voltage drop: 1.5 V or less

### PFCA7##-##-1#-###

Analogue output: 1 to 5 V or 0 to 10 V

Output impedance: 1 k $\Omega$  approx.

Analogue input: 1 to 5 V

Input impedance: 1 M $\Omega$  approx.

### PFCA7##-##-2#-###

Analogue output: 4 to 20 mA

Load impedance: 50 to 600  $\Omega$

Analogue input: 4 to 20 mA

Input impedance: 250  $\Omega$  or less

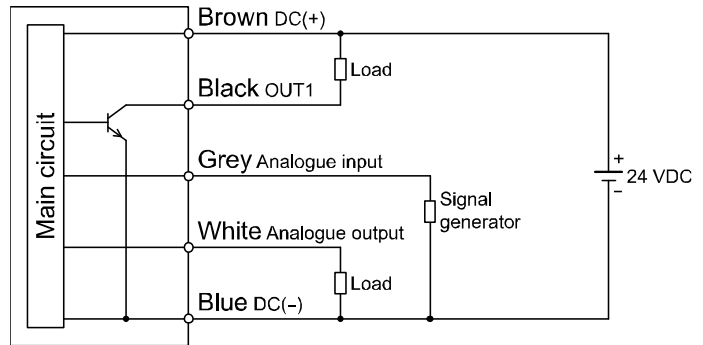

PNP type

Maximum load current: 80 mA

Internal voltage drop: 1.5 V or less

### PFCA7##-##-1#-###

Analogue output: 1 to 5 V or 0 to 10 V

Output impedance: 1 k $\Omega$  approx.

Analogue input: 1 to 5 V

Input impedance: 1 M $\Omega$  approx.

### PFCA7##-##-2#-###

Analogue output: 4 to 20 mA

Load impedance: 50 to 600  $\Omega$

Analogue input: 4 to 20 mA

Input impedance: 250  $\Omega$  or less

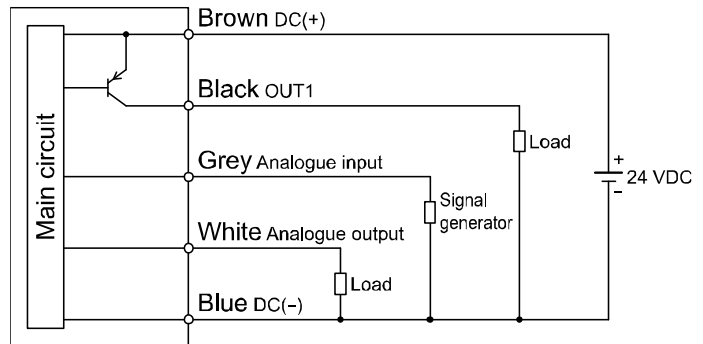

## When used as an IO-Link device

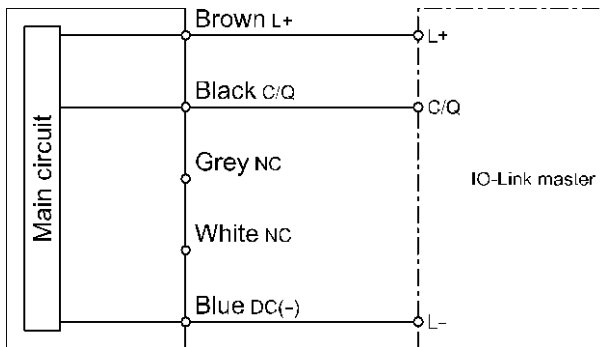

# Outline of Settings [Measurement Mode]

Power is supplied

The flow rate control action and each output are forced to turn OFF for 3 seconds after turning on the power supply, and the SMC logo appears.

## [Measurement mode]

Measurement mode is the condition where flow control and the switching operation are performed after turning on the power supply. This is the basic mode; other modes should be selected for set-point changes and other function settings.

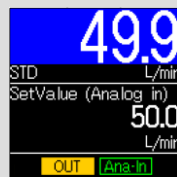

### Sub display

In measurement mode, the content of the Sub display can be selected by pressing the UP or DOWN button.



Commanded flow rate display

Peak/bottom display

Accumulated flow rate value display

IO-Link mode display

Line name \*display\*

\*: Only when line name is ON.

Press the SET button for between 2 and 4 seconds.

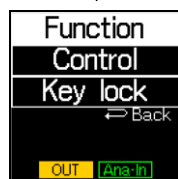

Mode selection

Press the UP or DOWN button to select the item and then press the SET button.

### [Function]

Shifts to function selection mode. Set functions. (Refer to page 22)

### [Control]

Shifts to control selection setting mode. Set the flow rate control command method. (Refer to page 48)

### [Key lock]

Shifts to key-lock setting mode. Set restrictions for button operation. (Refer to page 51)

## [Function Selection Mode] to Change Settings

### Function Selection Mode

In this mode, each function setting can be changed separately.

**In measurement mode, press the SET button for between 2 and 4 seconds, and then select [Function] to enter function selection mode.**

By pressing the UP or DOWN button to change the number, each function that you want to change can be selected.

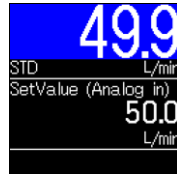

Press the SET button for between 2 and 4 seconds.

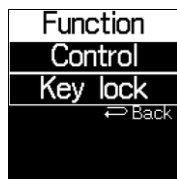

Press the SET button.

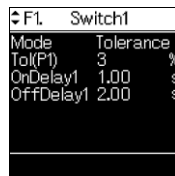
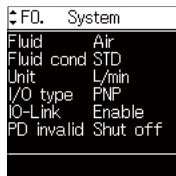

.....

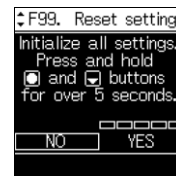

Press the SET button.

F0 function setting



Press the SET button.

F1 function setting



Press the SET button.

F99 function setting

### After the setting is complete:

To return to function selection mode:	To return to measurement mode:
Use the UP or DOWN button to select [Back]	Press the SET button <u>for at least 2 seconds</u>

## ■ Factory default setting

No	Function	Item	Default setting	Page
[F0]	System settings	[Fluid] Fluid settings	[Air] Air	Page 24
		[Fluid cond] Flow rate reference condition setting	[STD] Standard condition	
		[Unit] Flow rate display unit setting	[L/min] L/min (L)	
		[I/O type] Switching between the NPN and PNP output	[PNP] PNP output	
		[IO-Link] IO-Link enable/disable setting	[Enable] Enable	
		[PD invalid] Output PD setting at communication error	[Shut off] Output PD: 0	
[F1]	OUT1 settings	[Mode] Output mode selection	[Tolerance] Limit deviation tolerance mode	Page 28
		[tol(P1)] Limit deviation tolerance setting	[ 3 %] 3% of rated control flow	
		[OnDelay1] ON delay time setting	[0.00 s] 0 second	
		[OffDelay1] OFF delay time setting	[0.00 s] 0 second	
[F10]	Measurement settings	[Resolution] Display resolution setting	[Low] 100 resolution	Page 32
[F22]	Analogue output settings	[Type] Analogue output switching setting	[1-5V] 1 to 5 V (Analogue voltage type) [4-20mA] 4 to 20 mA (Analogue current type) *: The setting cannot be changed for the analogue current type.	Page 33
		[Free span] Analogue free range setting	[10.00L/min] 10 L/min (For the PFCA710, the upper limit of the rated control flow.)	
[F30]	Accumulated flow (rate) settings	[Save intvl] Accumulation storage setting	[No save] Not to hold	Page 35
		[Disp mode] Accumulated display direction setting	[Increment] Addition direction	
		[Auto shut] Automatic accumulation shut-off enable/disable	[Disable] Disable	
[F80]	Display settings	[Colour] Selection of measurement value display colour	[1onB,offR] ON: Blue; OFF: Red	Page 37
		[Display] Display OFF setting	[ON] Display ON	
		[Rotation] Display rotation angle setting	[0deg] Rotation angle 0°	
		[Brightness] Display brightness setting	[100%] Brightness 100%	
		[Line name] Line name display setting	[OFF] No line name displayed	
[F81]	PIN code settings	Selection of PIN code	[OFF] Not used	Page 41
[F91]	Device information	-	Information check (No settings)	Page 42
[F96]	Input check	-	Input check (No settings)	Page 43
[F98]	Output check	-	[Normal] Normal output	Page 44
[F99]	Reset to factory default settings	-	[ oFF] Not to be reset	Page 47
-	Control Selection Setting Mode	[Ctrmode] Flow rate control command method setting	[Remote] Analogue input or IO-Link communication	Page 48

## ■[F0 System] System settings

Set the following items:

- (1) Fluid
- (2) Reference condition
- (3) Display units
- (4) Switching between NPN and PNP output
- (5) IO-Link enable/disable
- (6) Output PD setting at communication error

<Operation>

Press the UP or DOWN button in function selection mode to select [F0 System].

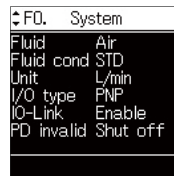

Press the UP or DOWN button to select the item and then press the SET button.



Shifts to the settings of each item.

### (1) Fluid settings

Select [Fluid].

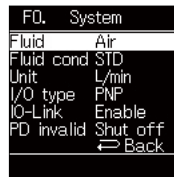

Press the SET button.



Press the UP or DOWN button to select an item.

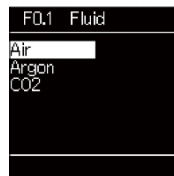

Air: Dry air, Nitrogen  
Argon: Argon  
CO<sub>2</sub>: Carbon dioxide

Press the SET button.



Returns to the [F0 System] settings.



## (2) Reference condition settings

Select [Fluid cond].

```
F0. System
Fluid Air
Fluid cond STD
Unit L/min
I/O type PNP
IO-Link Enable
FD invalid Shut off
Back
```

Press the SET button. ↓

Press the UP or DOWN button to select an item.

```
F0.2 Fluid cond
STD
NOR
```

STD: Standard condition (Flow rate converted into volume at a temperature of 20[°C], absolute pressure of 101.3[kPa], and humidity of 65[%R.H.]

NOR: Normal condition (Flow rate converted into volume at a temperature of 0[°C], absolute pressure of 101.3[kPa], and humidity of 0[%R.H.]

Press the SET button. ↓

Returns to the [F0 System] settings.

## (3) Display unit settings

Select [Unit].

```
F0. System
Fluid Air
Fluid cond STD
Unit L/min
I/O type PNP
IO-Link Enable
FD invalid Shut off
Back
```

Press the SET button. ↓

Press the UP or DOWN button to select an item.

```
F0.3 Unit
L/min
cfm
```

\*: A product with no units selection function (fixed to SI units) does not indicate the display unit [cfm].

Press the SET button. ↓

Returns to the [F0 System] settings.

#### (4) Switching between NPN and PNP output

Select [I/O type].

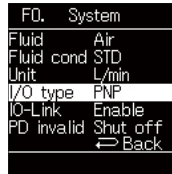

Press the SET button. ↓

Press the UP or DOWN button to select an item.

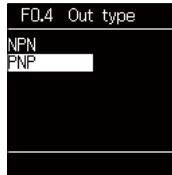

NPN: NPN output  
PNP: PNP output

Press the SET button. ↓

Returns to the [F0 System] settings.

#### (5) IO-Link enable/disable setting

Select [IO-Link].

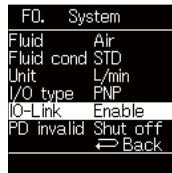

Press the SET button. ↓

Press the UP or DOWN button to select an item.

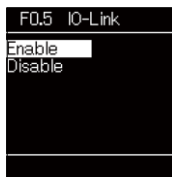

Enable: IO-Link enable  
Disable: IO-Link disable

- \*: When changing the setting from disable to enable, the switch output turns OFF for 100  $\mu$ s.
- \*: Do not set to disable while communicating via IO-Link.
- \*: If IO-Link communication is performed in the disabled state, an overcurrent error (Err1) may be displayed. Do not connect the IO-Link master (IO-Link communication) in the disabled state.

Press the SET button. ↓

Returns to the [F0 System] settings.

## (6) Output process data setting at communication error

Select [PD invalid].

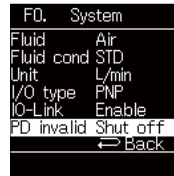

Press the SET button. ↓

Press the UP or DOWN button to select an item.



Set the output process data behavior in the event of an IO-Link communication error.  
Shut off: The output process data is set to "0" in the event of an IO-Link communication error.  
Keep last: The output process data holds the last received data in the event of an IO-Link communication error.

Press the SET button. ↓

Returns to the [F0 System] settings.



Completion of the [F0 System] setting

## ■ [F1 Switch1] OUT1 settings

Set the output mode of OUT1.

<Operation>

Operate the UP or DOWN button in function selection mode to select [F1 Switch].

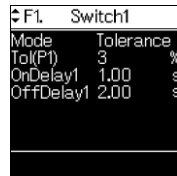

Press the UP or DOWN button to select an item and press the SET button.

Shifts to the output operation setting.

### Output operation settings

Select [Mode].

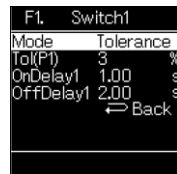

Press the SET button.

Press the UP or DOWN button to select an item.

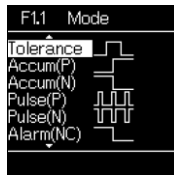

Page 1

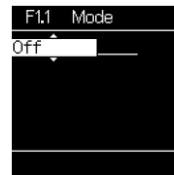

Page 2

Tolerance: When the flow meter measurement is within the tolerance value for the commanded flow rate, the SW output is turned ON. (Limit deviation tolerance mode)

Accum (P): When the accumulated flow (rate) is the set value or more, the switch output is turned ON. (Accumulated output mode)

Accum (N): When the accumulated flow (rate) is the set value or more, the switch output is turned OFF. (Accumulated output mode)

Pulse (P): The switch output is turned ON for 0.05 seconds for each accumulated pulse conversion value. (Accumulated pulse output mode)

Pulse (N): The switch output is turned OFF for 0.05 seconds for each accumulated pulse conversion value. (Accumulated pulse output mode)

Alarm (NC): The switch output is turned OFF when an error code is displayed \*. (Error output mode)

Off: The switch output is always turned OFF. (Switch output OFF mode)

\*: The zero clear error (Err3) is not applicable.

Press the SET button.

Returns to the [F1 Switch1] OUT1 settings.

When Tolerance is selected → Page 29

When Accum (P)/Accum (N) is selected → Page 31

When other than the above is selected → The settings are complete. Select [Back] and return to function selection mode.

•When Tolerance (Limit deviation tolerance mode) is selected:

### Limit deviation tolerance setting

Select [Tol(P1)].

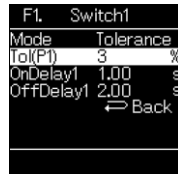

Press the SET button. ↓

Press the UP or DOWN button to change the value.

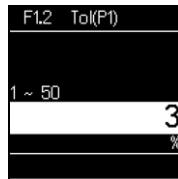

\*: Limit deviation tolerance setting range: 1 to 50[%]

Press the SET button. ↓

Returns to the [F1 Switch1] OUT1 settings.

### On-delay setting

Select [OnDelay1].

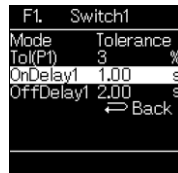

Press the SET button. ↓

Press the UP or DOWN button to change the value.

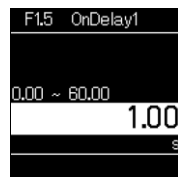

\*: On-delay time setting range: 0.00 to 60.00[s]

Press the SET button. ↓

Returns to the [F1 Switch1] OUT1 settings.

## Off-delay setting

Select [OffDelay1].

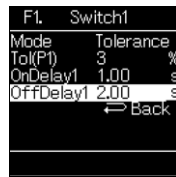

Press the SET button.



Press the UP or DOWN button to change the value.

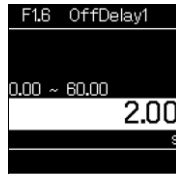

\*: Off-delay time setting range: 0.00 to 60.00[s]

Press the SET button.



Returns to the [F1 Switch1] OUT1 settings.

•When Accum (P)/Accum (N) (Accumulated output mode) is selected:

### Setting the threshold value

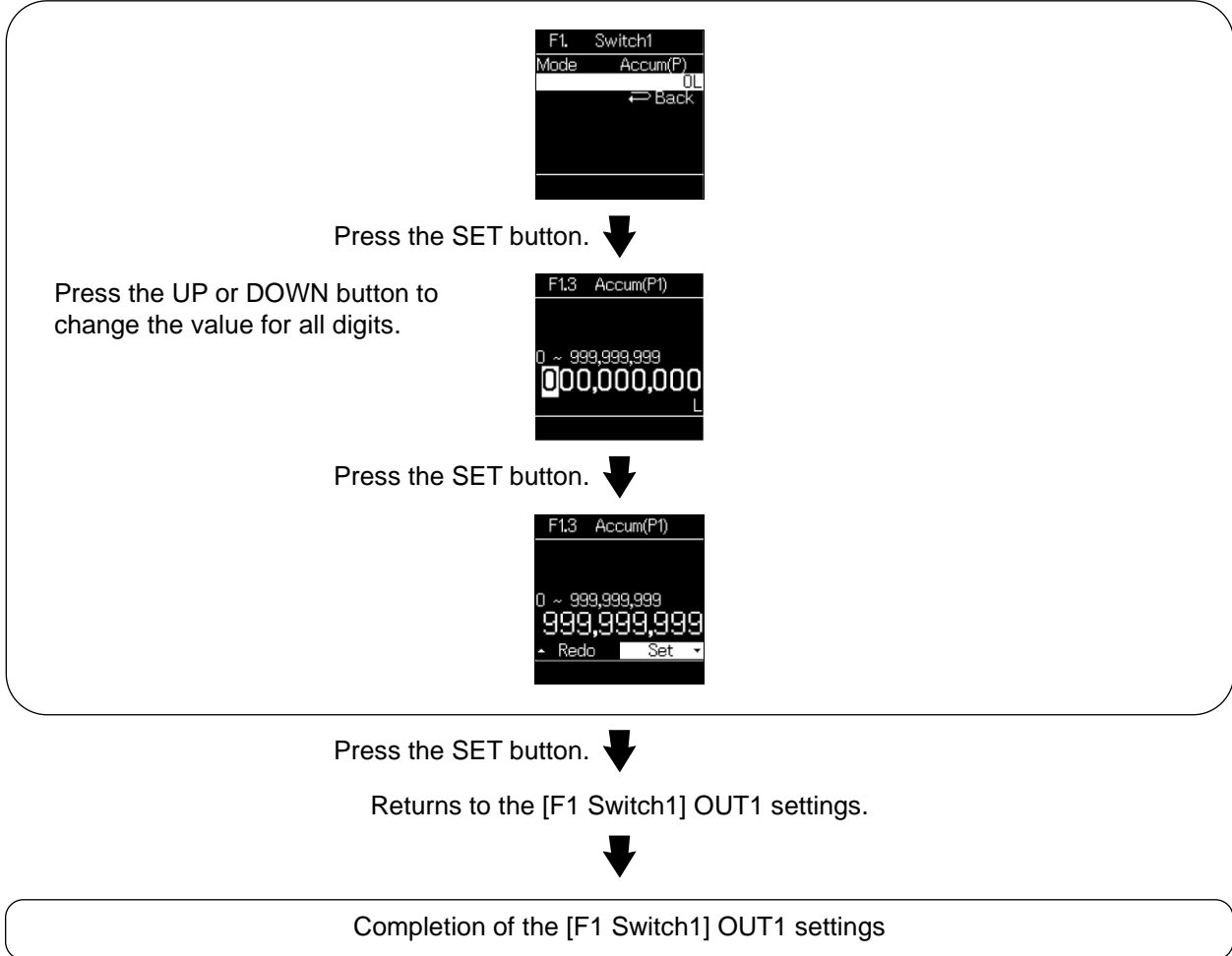

## ■ [F10 Measure] Measurement settings

This setting is available only for the 10 L/min type and the 100 L/min type.  
The display resolution can be set.

### <Operation>

Press the UP or DOWN button in function selection mode to select [F10 Measure].

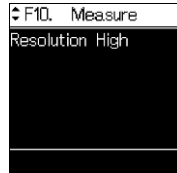

Press the SET button. ↓ Shifts to the resolution setting.

### Display resolution setting

Select [Resolution].

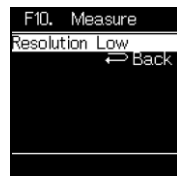

Press the SET button. ↓

Press the UP or DOWN button to select an item.

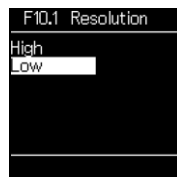

High: 1000 resolution  
Low: 100 resolution

Press the SET button. ↓

Returns to the [F10 Measure] settings.



Completion of the [F10 Measure] settings



## ■ [F22 Analog out] Analogue output settings

Change the analogue output set value and analogue free span range.

### <Operation>

Press UP or DOWN button in function selection mode to select [F22 Analog out].

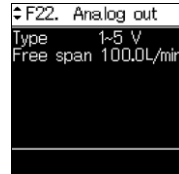

Press the UP or DOWN button to select an item and press the SET button.



Shifts to the settings of each item.

### Analogue output setting (voltage output only)

Select [Type].

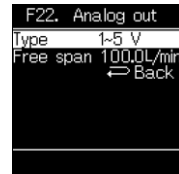

Press the SET button.



Press the UP or DOWN button to select an item.

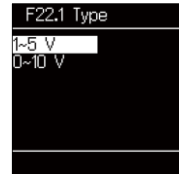

\*: When using current output, [4-20 mA] is displayed and the setting cannot be changed.

Press the SET button.



Returns to the [F22 Analog out] analogue output settings.

## Setting of the analogue free span function

Select [Free span].

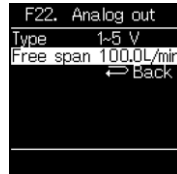

Press the SET button.

Press the UP or DOWN button to change the value.

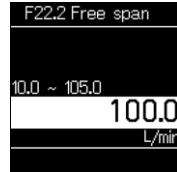

Press the UP and DOWN button to set the flow value that will be output 5 V (10 V) or 20 mA. A flow value can be set in the range from 10% of the maximum rated control flow to the maximum displayable value.

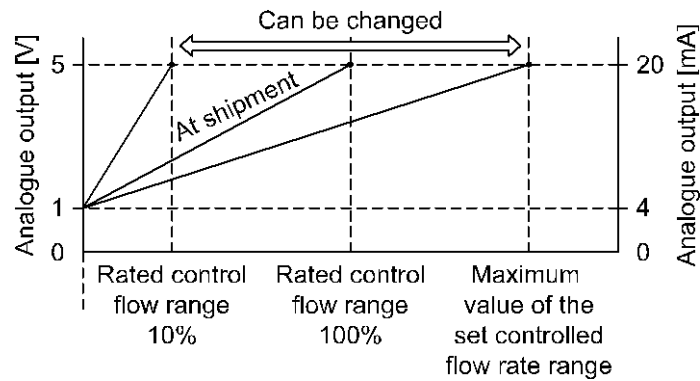

Press the SET button.

Returns to the [F22 Analog out] analogue output settings.

Completion of the [F22 Analog out] analogue output settings

## ■ [F30 Accumulate] Accumulated flow (rate) settings

Set the accumulated flow (rate) function.

<Operation>

Press the UP or DOWN button in function selection mode to select [F30 Accumulate].

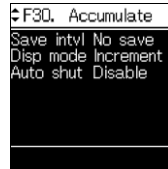

Press the UP or DOWN button to select an item and press the SET button.



Shifts to the settings of each item.

### Setting of the accumulated-value hold function

Select [Save intvl].

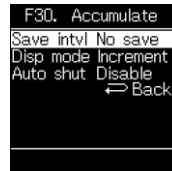

Press the SET button.



Press the UP or DOWN button to select an item.

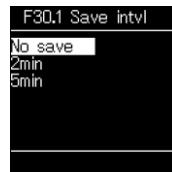

No save: The accumulated flow (rate) is not stored.

2 min: The accumulated flow (rate) is stored at a 2 minute interval.

5 min: The accumulated flow (rate) is stored at a 5 minute interval.

\*: When using the accumulated value hold function, calculate the product life from the operating conditions, and use the product within its life.

The maximum access limit of the memory device is approximately 1 million cycles.

•Data stored every 5 minutes: 5 minutes x 1 million times = 5 million minutes = 9.5 years approx.

•Data stored every 2 minutes: 2 minutes x 1 million times = 2 million minutes = 3.8 years approx.

\*: The value is stored in memory every 2 or 5 minutes.

If the power supply is turned off, the accumulated flow since the last time it was stored will be lost.

\*: When the power supply is turned on again, the accumulated flow count will start from the last value recorded at B.

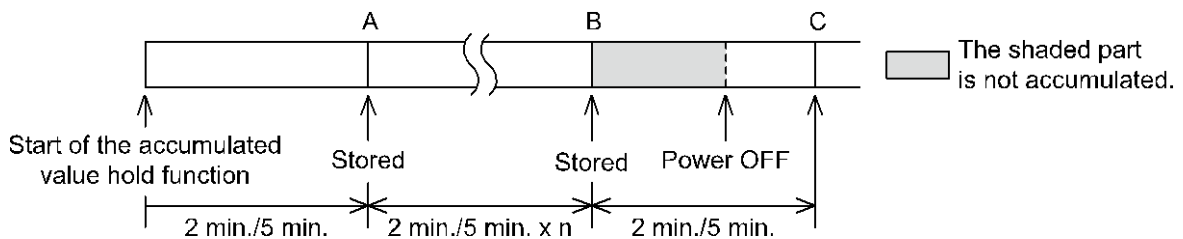

Press the SET button.



Returns to the [F30 Accumulate] accumulated flow (rate) settings.

### Accumulated addition/subtraction setting

Select [Disp mode].

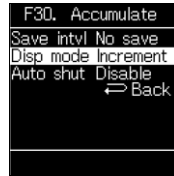

Press the SET button.

Press the UP or DOWN button to select an item.

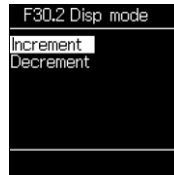

Increment: Displays the accumulated measurement in the addition direction.  
Decrement: Displays the accumulated measurement in the subtraction direction.

Press the SET button.

Returns to the [F30 Accumulate] accumulated flow (rate) settings.

### Automatic accumulation shut-off setting

Select [Auto shut].

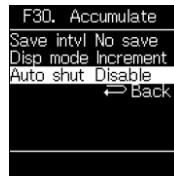

Press the SET button.

Press the UP or DOWN button to select an item.

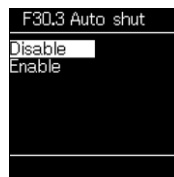

Disable: Automatic accumulation shut-off is disabled.

Enable: Automatic accumulation shut-off is enabled.

When automatic accumulation shut-off is enabled, if the accumulation threshold is exceeded, [Automatic shutoff] is displayed on the display and the control operation is stopped.

Press the SET button.

Returns to the [F30 Accumulate] accumulated flow (rate) settings.

Completion of the [F30 Accumulate] accumulated flow (rate) setting

## ■ [F80 Display] Display settings

Set the display function.

<Operation>

Press the UP or DOWN button in function selection mode to select [F80 Display].

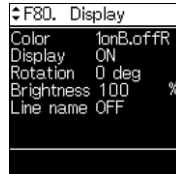

Press the UP or DOWN button to select an item and press the SET button.



Shifts to the settings of each item.

### Display colour setting

Select [Color].



Press the SET button.



Press the UP or DOWN button to select an item.

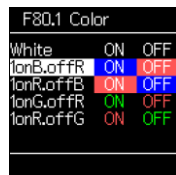

White: Fixed to white characters on a black background

1onB.offR: Switch output ON = White characters on a blue background; OFF = White characters on a red background

1onR.offB: Switch output ON = White characters on a red background; OFF = White characters on a blue background

1onG.offR: Switch output ON = Green characters on a black background; OFF = Red characters on a black background

1onR.offG: Switch output ON = Red characters on a black background; OFF = Green characters on a black background

Press the SET button.



Returns to the [F80 Display] settings.

## Display OFF setting

Select [Display].



Press the SET button.

Press the UP or DOWN button to select an item.

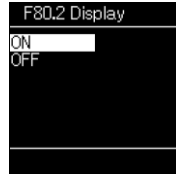

ON: Normal display

OFF: Shifts to display off mode.

In measurement mode, [ · · · ] is displayed.

Each icon turns on according to the status at a lower brightness.

With the display OFF mode, when a key operation is performed, normal operation is available. When a key operation is not performed for 30 seconds, the display will return to the display OFF mode.

(Only in measurement mode)



Display OFF mode

Press the SET button.

Returns to the [F80 Display] settings.

## Display rotation angle setting

Select [Rotation].



Press the SET button. ↓

Press the UP or DOWN button to select an item.

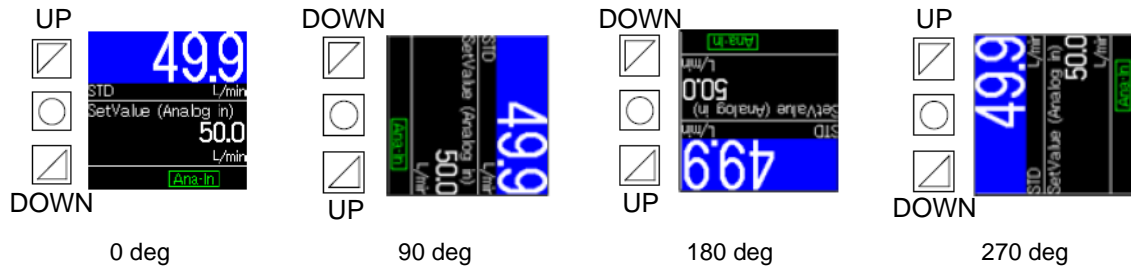
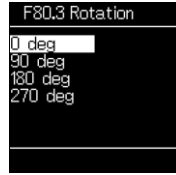

The assignment of the UP and DOWN buttons changes depending on the display rotation angle.

Press the SET button. ↓

Returns to the [F80 Display] settings.

## Display brightness setting

Select [Brightness].



Press the SET button. ↓

Press the UP or DOWN button to change the value.

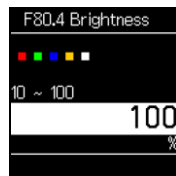

\*: The value can be changed in a range between 10 and 100%.

Press the SET button. ↓

Returns to the [F80 Display] settings.

## Line name display setting

Select [Line name].



Press the SET button.

Press the UP or DOWN button to select an item.

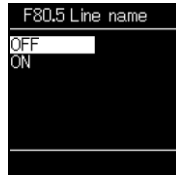

When [OFF] is selected:  
Press the SET button to save the setting.

When [ON] is selected:  
Press the SET button to save the setting.

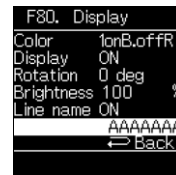

Press the SET button.

Press the UP or DOWN button to change the character for all digits.

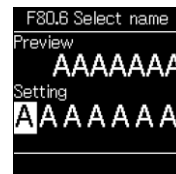

Press the SET button.

Returns to the [F80 Display] settings.

Completion of the [F80 Display] settings



## ■ [F81 PIN code] PIN code settings

Set the PIN code used for the key lock function.

### <Operation>

Operate the UP or DOWN button in function selection mode to select [F81 PIN code].

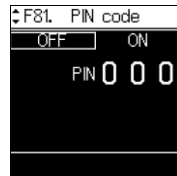

Press the SET button. ↓ Shifts to the PIN code setting.

### PIN code setting

Press the UP or DOWN button to select an item.

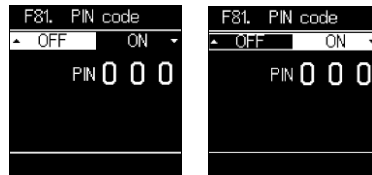

OFF: PIN code is not used.

ON: Shifts to the PIN code setting.

### When [OFF] is selected:

Press the SET button to return to function selection mode.

### When [ON] is selected:

Press the SET button to move on to checking the PIN code setting.

### Checking the PIN code setting

Press the UP or DOWN button to enter the current PIN code.  
(The factory default setting is 000.)

If the PIN code entered is incorrect, [PIN mismatch] will be displayed, and the PIN code must be entered again.  
If the wrong PIN code is entered 3 times, [Failed 3 times] is displayed and the device returns to function selection mode.

Press the SET button. ↓

### Entering a new PIN code

Press the UP or DOWN button to enter a new PIN code.

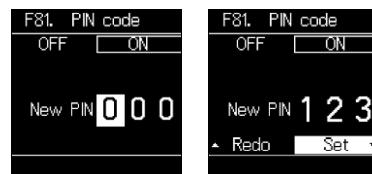
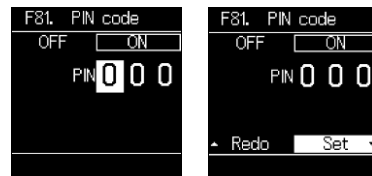

Press the SET button. ↓

Returns to function selection mode.

Completion of the [F81 PIN code] PIN code setting

## ■ [F91 Device info] Checking device information

The device information can be checked.

<Operation>

Operate the UP or DOWN button in function selection mode to select [F91 Device info].

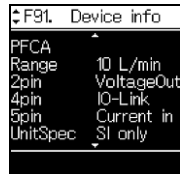

Press the SET button. ↓ Shifts to the checking of device information.

### Checking the device information

Press the UP or DOWN button to select an item.

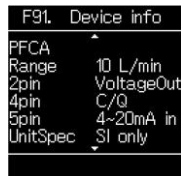

Page 1

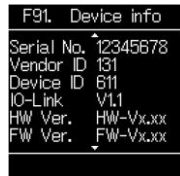

Page 2



Page 3

Press the SET button on one of the pages. ↓ Returns to function selection mode.

Completion of the [F91 Device info] device information check.

## ■[F96 Input check] Checking input signal

The input signal can be checked.

### <Operation>

Operate the UP or DOWN button in function selection mode to select [F96 Input check].

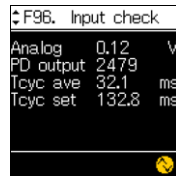

Analog: Analogue input voltage or analogue input current

PD output: Process data output ("---" in SIO mode)

Tcyc ave: Cycle time measurement ("---" in SIO mode)

Tcyc set: Cycle time setting ("---" in SIO mode)



Completion of the [F96 Input check] input signal check

## ■[F98 Output check] Checking output signal

The operation of the system can be checked by forcibly switching the output ON/OFF operation without applying the flow rate.

<Operation>

Operate the UP or DOWN button in function selection mode to select [F98 Output check].

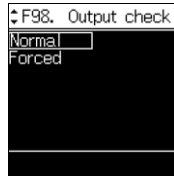

Press the SET button. ↓ Shifts to the settings of each item.

### Normal output

Check the current output signal.  
Select Normal.

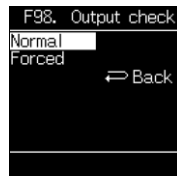

Press the SET button. ↓

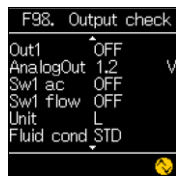

Page 1

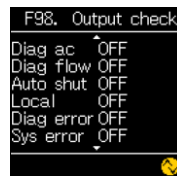

Page 2

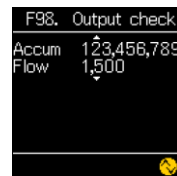

Page 3

Press the SET button on one of the pages. ↓

Returns to the [F98 Output check] output signal check.

## Forced output

The output signal can be forcibly changed.  
Select Forced.

\*: When the output has been checked via IO-Link communication, "by Comm" appears by the side of "Forced."

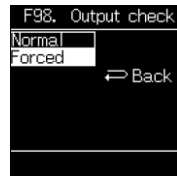

Press the SET button.

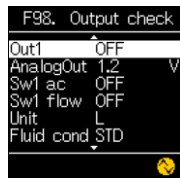

Page 1

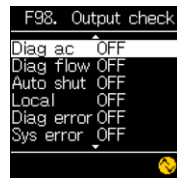

Page 2

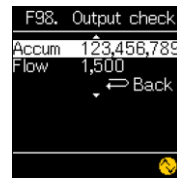

Page 3

Press the SET button on page 1.

The output of the set item switches.

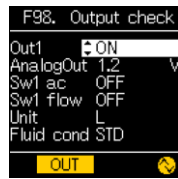
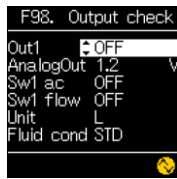

Press the SET button.

Returns to the [F98 Output check] output signal check.

Press the SET button on pages 2 and 3.

Completion of the [F98 Output check] output signal check

\*: The output set with forced output returns to the current output if the device returns to [F98 Output check] or measurement mode.

[F98] Details of items

Item	Description	Setting		Remarks
Out1	Hardware output	ON/OFF		
AnalogOut	Analogue output	Voltage type	1.0 V/5.0 V or 0.0 V/10.0 V	"---" appears in process data bit switching SIO mode and switching is not available.
		Current type	4 mA/20 mA	
Sw1 ac	Accumulated flow SW judgment	ON/OFF		
Sw1 flow	Flow rate SW judgment	ON/OFF		
Unit	Flow rate display unit	L/ft <sup>3</sup>		
Fluid cond	Flow rate reference condition	STD/NOR		
Dlag ac	Accumulation diagnosis	ON/OFF		
Diag flow	Flow rate diagnostics	ON/OFF		
Auto shut	Automatic accumulation shut-off	ON/OFF		
Local	Control selection	ON/OFF		
Diag error	Error diagnosis (Other than system error)	ON/OFF		
Sys error	Error diagnosis (System error)	ON/OFF		
Accum	Accumulated measurement process data	0/999999999		
Flow	Hardware output	0/4000		

## ■[F99 Reset setting] Resetting to the factory default settings

If the product settings are uncertain, the factory default values can be restored.

<Operation>

Press the UP or DOWN button in function selection mode to display [F99 Reset setting].



Press the SET button. ↓ Shifts to resetting to the factory default settings.

### Resetting to the factory default settings

Press the UP or DOWN button to select [Yes].



Press the SET button. ↓

Press and hold the DOWN and SET buttons for 5 seconds.



Press the SET button. ↓ Returns to function selection mode.

Completion of the [F99 Reset setting] resetting to the factory default settings

## [Control Selection Setting Mode] to Change the Flow Rate Control Command Method

### What is control selection setting mode?

The flow control settings can be changed.

In measurement setting mode, press the SET button for between 2 and 4 seconds, and then select [Control] to enter control selection setting mode.

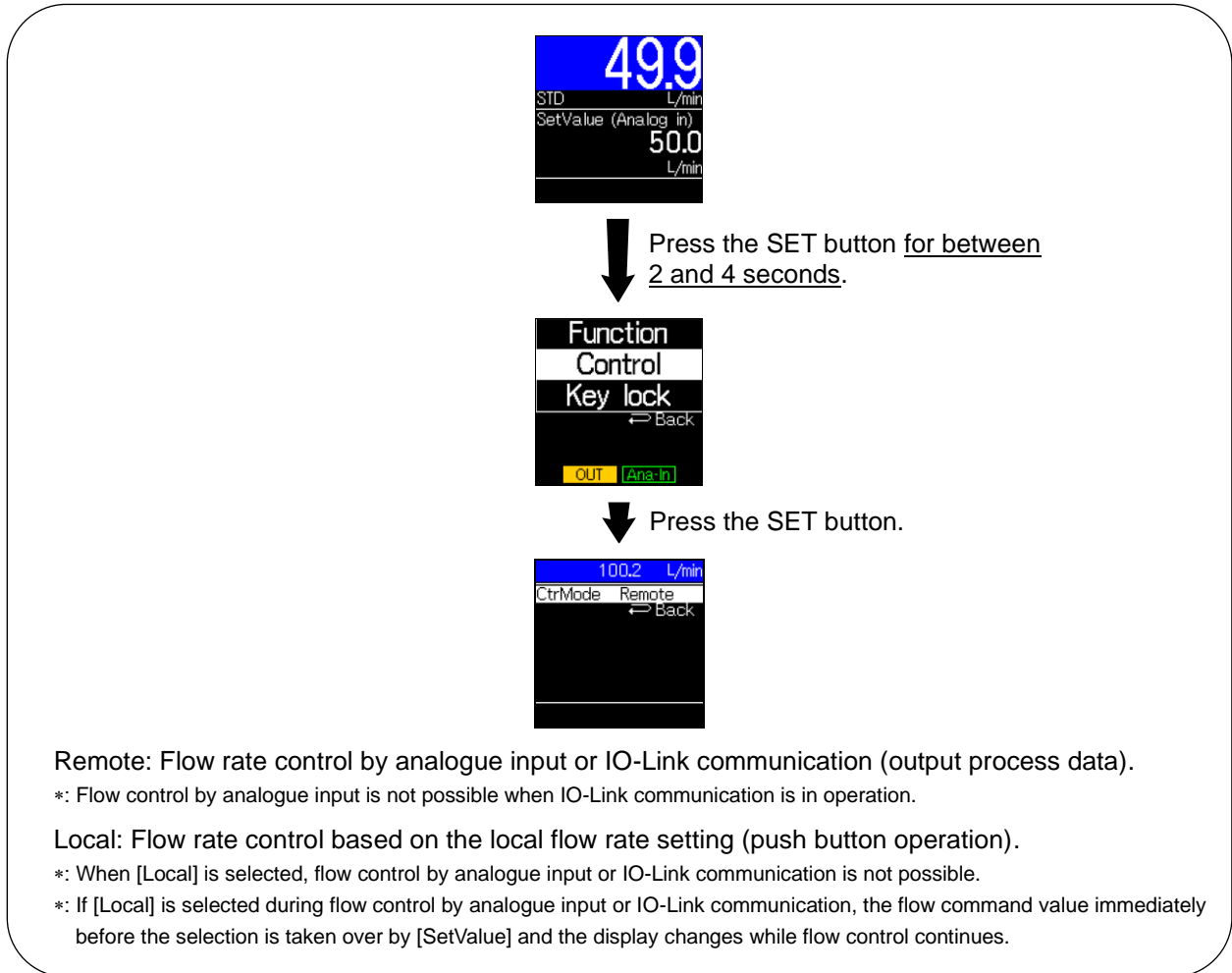

Select [Remote] and press the SET button.

Select [Local] and press the SET button.

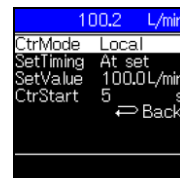
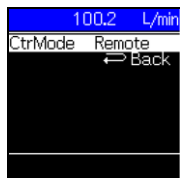

Select [Back] and press and hold the SET button for 2 seconds or longer to enter function selection mode.

Refer to the next page for detailed settings.



•When Local is selected:

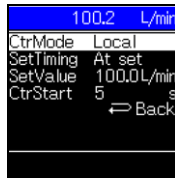

Press the UP or DOWN button. ↓ Shifts to the settings of each item.

### Setting the timing to enable the set value

Select [SetTiming].



Press the SET button. ↓

Press the UP or DOWN button to select an item.



At set: Apply the setting by confirming (with the SET button) the local flow rate setting value.  
Direct: Apply the setting by changing (with the UP or DOWN button) the local flow rate setting value.

Press the SET button. ↓

Returns to "When Local is selected:".

### Setting of the local flow rate setting

Select [SetValue].

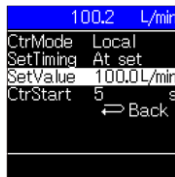

Press the SET button. ↓

Press the UP or DOWN button to change the value.

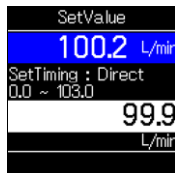

Press the SET button. ↓

Returns to "When Local is selected:".

## Time to start local control operation

Select [CtrStart].



Press the SET button.

Press the UP or DOWN button to change the value.

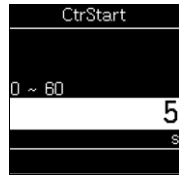

\*: Setting of the time from transition to measurement mode after turning on the power supply to the start of control operation.  
Local control operation start time setting range: 0.00 to 60.00[s]

Press the SET button.

Select [Back] and press and hold the SET button for 2 seconds or longer to enter function selection mode.

## [Key-Lock Setting Mode] to Limit Button Operations

### What is key-lock mode?

In key-lock mode, settings other than those for key-lock operations cannot be changed. The key lock function is used to prevent errors occurring due to unintentional changes of the set values.

In measurement setting mode, press the SET button for between 2 and 4 seconds, and then select [Key lock] to enter Key-lock setting mode.

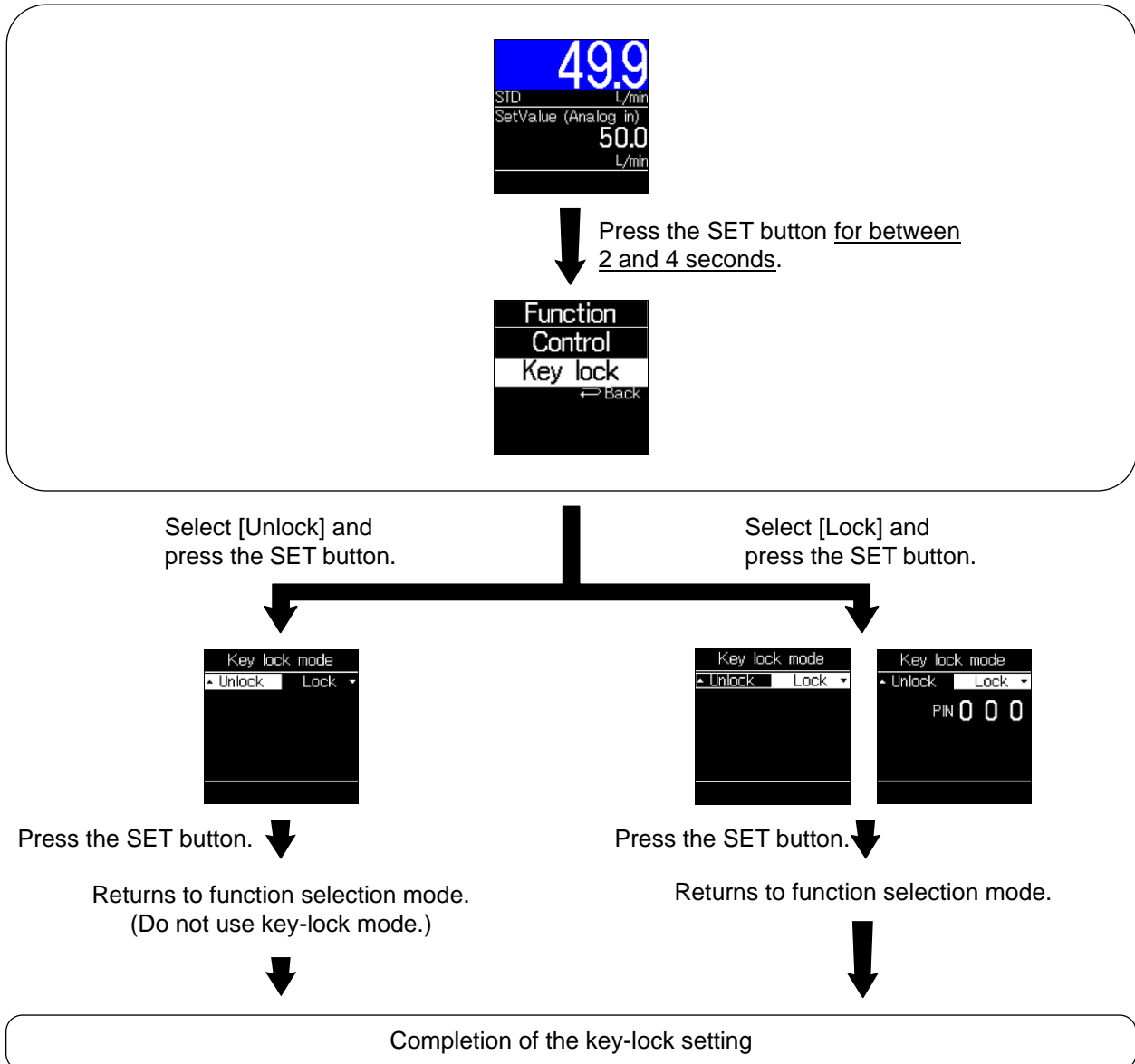

\*: An icon appears in the lower left in key-lock mode.

\*: When the SET button is pressed or a reset operation is performed, [Status: Lock] is displayed and the operation is disabled.

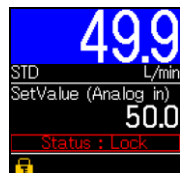

•Unlocking

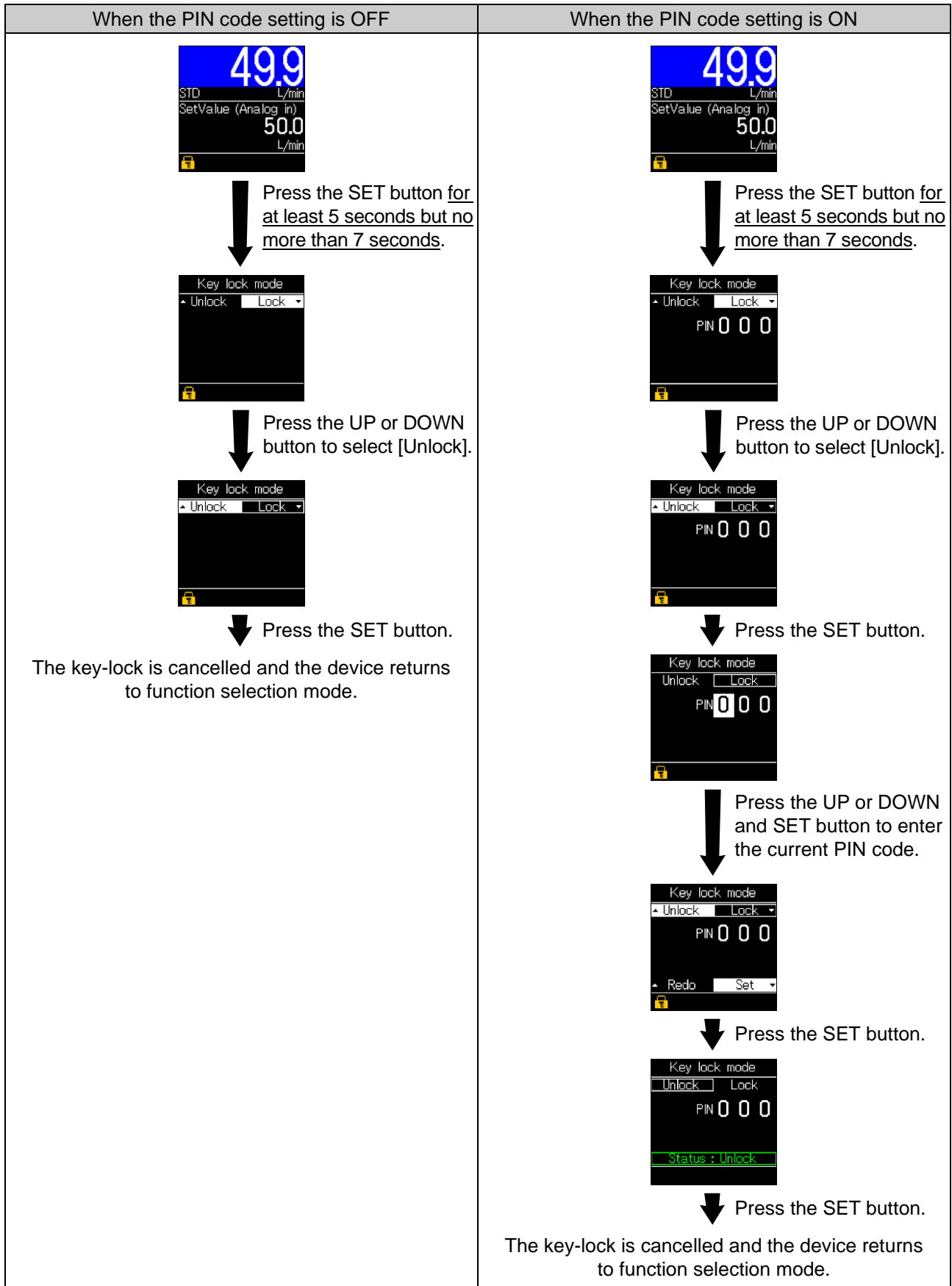

## Other Settings

### Reset operation

When the sub display is displaying the accumulated flow rate or peak/bottom, press and hold the SET and DOWN button simultaneously for 1 second or longer to display [Reset] in the sub display, allowing the values to be reset. The accumulated flow (rate) and the peak/bottom values can also be reset by turning off the power supply.

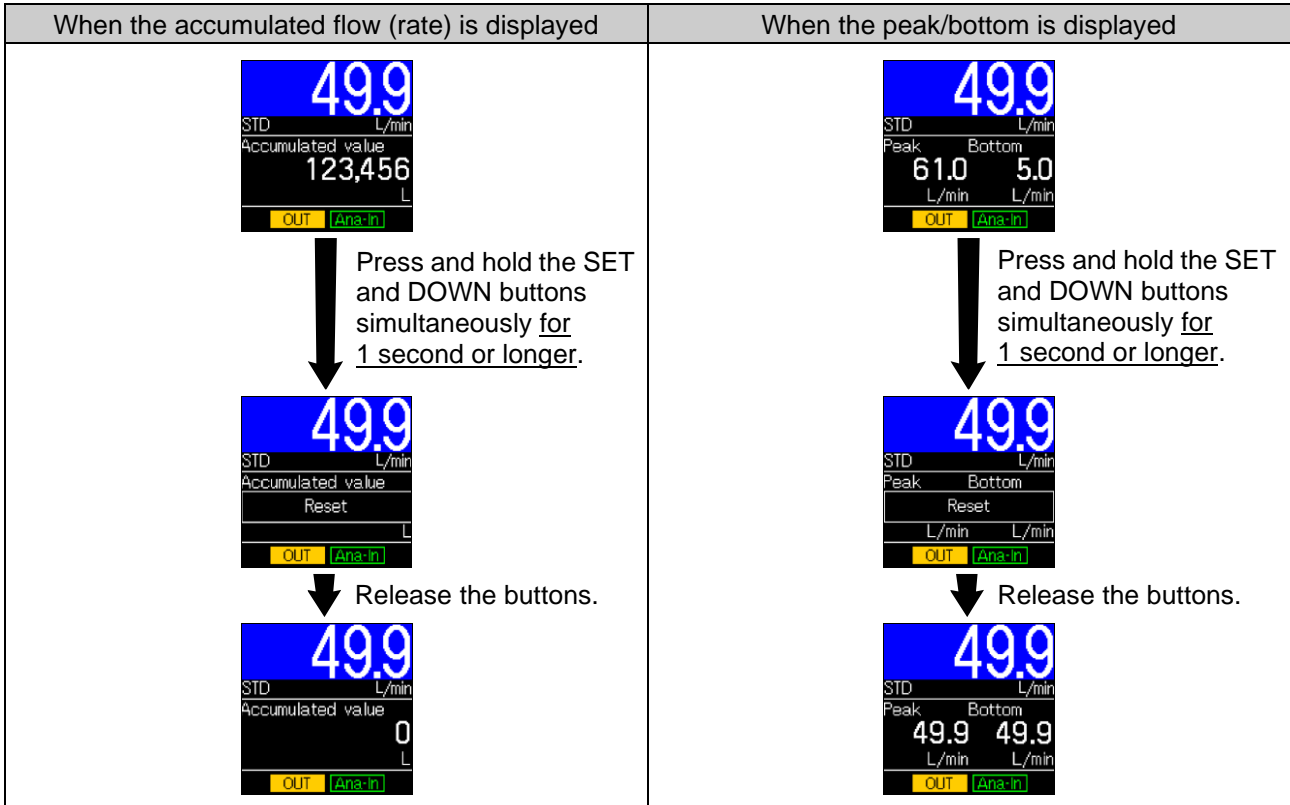

### Zero-clear function

The measured flow rate display value can be cleared to zero by pressing and holding the UP and DOWN buttons simultaneously for 1 second or longer in measurement mode. The value can be adjusted within the range  $\pm 5\%$ F.S. from the default condition.

\*: When using the zero-clear function, set the command flow rate to zero.

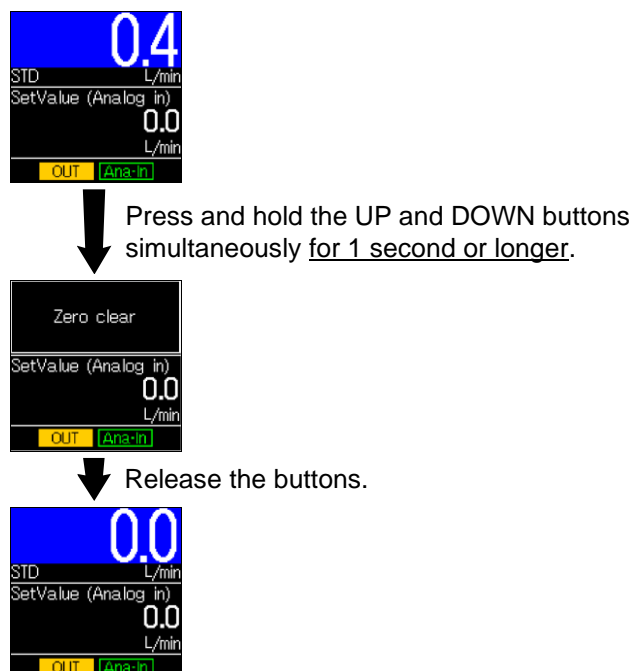

## Maintenance

### How to reset the product after a power loss or when the power has been unexpectedly removed

The settings for the product are retained in memory prior to the power loss or de-energizing of the product. The output condition is also recoverable to that prior to the power loss or de-energizing. However, this may change depending on the operating environment. Therefore, check the safety of the whole installation before operating the product.

If the installation is using accurate control, wait until the product has warmed up (approximately 10 to 15 minutes) before operation.

## IO-Link Specifications

### ■ IO-Link function overview

#### ○ Communication function

This product can check the commanded flow rate setting as well as the measurement value, diagnostic information, and switch output status through the cyclic data communication via the IO-Link system.

#### ○ Product status monitoring function

This function monitors the product status via IO-Link.

- Multiple error conditions (e.g. internal hardware errors) can be monitored.
- Multiple warning conditions (flow rate measurement error, etc.) can be detected.

#### ○ Data storage function

The data storage function stores the IO-Link device parameter settings to the IO-Link master.

With the IO-Link data storage function, the IO-link device can be replaced easily without re-setting the equipment construction or setting the parameters.

When the device parameters are set and downloaded to the device using the IO-Link setting tool, the parameters will be uploaded to the data storage in the master by the system command after download (backup instruction by the communication command).

When the device is replaced with the same type of IO-Link device due to failure, the parameter settings stored in the master are downloaded automatically, and the device can be operated using the parameter settings of the previous device.

Device parameter setting is applicable to 3 types of back-up levels of the master setting ("Inactive", "Back-up/Restore", "Restore").

"Back-up" implies the activation of an upload and "restore" implies a download.

### ■ Communication Specifications

IO-Link type	Device
IO-Link version	V1.1
Communication speed	COM2 (38.4 kbps)
Min. cycle time	5.5 ms
Process data length	Input Data: 8 bytes, Output Data: 2 bytes
On request data communication	Available
Data storage function	Available
Event function	Available

## ■ Process data

Process data is the data which is exchanged periodically between the master and device.

In this product, the process data consists of the following:

- Input process data (hereafter "PD\_IN")
- Output process data (hereafter "PD\_OUT")

### ○PD\_IN

Bit offset	Item	Remarks
0	Accumulated switch	0: OFF 1: ON
1	Limit deviation tolerance switch	0: OFF 1: ON
6	Flow rate units	0: L 1: ft <sup>3</sup>
7	Reference condition	0: STD 1: NOR
8	Accumulation diagnosis	0: Within the range 1: Outside the range (The upper/upper limit of the accumulation range has been reached)
9	Flow rate diagnostics	0: Within the range 1: Outside the range (Flow rate measurement: HHH/LLL)
10	Output PD diagnosis	0: Within the range 1: Outside the range (Outside the output process data range)
11	Accumulation shut-off	0: Automatic accumulation shut-off has not occurred 1: Automatic accumulation shut-off has occurred
12	Local input	0: Remote 1: Local (According to the control selection)
13	Fixed output	0: Normal output 1: Fixed output
14	Error	0: Error not generated 1: Error generated
15	System error	0: Error not generated 1: Error generated
16 to 31	Measured value of the flow meter	Signed: 16 bit
32 to 63	Accumulated measurement value	Unsigned: 32 bit

Bit offset	63	62	61	60	59	58	57	56	55	54	53	52	51	50	49	48
Item	Accumulated measurement value [upper byte]															

Bit offset	47	46	45	44	43	42	41	40	39	38	37	36	35	34	33	32
Item	Accumulated measurement value [lower byte]															

Bit offset	31	30	29	28	27	26	25	24	23	22	21	20	19	18	17	16
Item	Flow rate measurement															

Bit offset	15	14	13	12	11	10	9	8	7	6	5	4	3	2	1	0
Item	System error	Error	Fixed output	Local input	Accumulation shut-off	Output PD diagnosis	Flow rate diagnostics	Accumulation diagnosis	Reference condition	Flow rate units	Reserved				Limit deviation tolerance SW	Accumulated flow SW

○PD\_OUT

Bit offset	Item	Remarks
0 to 15	Commanded flow rate	Signed: 16 bit

Bit offset	15	14	13	12	11	10	9	8	7	6	5	4	3	2	1	0
Item	Commanded flow rate															

- The data process type of this product is Big-Endian.  
When the transmission method of the upper communication is Little-Endian, the byte order will be changed. Refer to the table below for the Endian type of the major upper communication.

Endian type	Upper communication protocol
Big-Endian type	Such as PROFIBUS and PROFINET
Little-Endian type	Such as EtherNET/IP, EtherCAT and CC-Link IE Field

○Measurement/command value (PD)

•Measurement value (PD\_IN)

Target	Units	Range	Rated control flow range			Displayable/settable range		
			Min.	to	Max.	Min.	to	Max.
Instantaneous flow	L/min	10 L/min	0.10	to	10.00	-0.50	to	10.50
		25 L/min	0.2	to	25.0	-1.3	to	26.3
		50 L/min	0.5	to	50.0	-2.5	to	52.5
		100 L/min	1.0	to	100.0	-5.0	to	105.0
	cfm	10 L/min	0.004	to	0.353	-0.018	to	0.371
		25 L/min	0.009	to	0.883	-0.044	to	0.927
		50 L/min	0.02	to	1.77	-0.09	to	1.85
		100 L/min	0.04	to	3.53	-0.18	to	3.71
Accumulated flow	L	10 L/min	0.0	to	99999999.9	0.0	to	99999999.9
		25, 50, 100 L/min	0	to	999999999	0	to	999999999
	Ft <sup>3</sup>	10, 25, 50 L/min	0.00	to	9999999.99	0.00	to	9999999.99
		100 L/min	0.0	to	999999999.9	0.0	to	999999999.9

Target	Units	Range	PD value					
			Rated control flow range			Display/settable range		
			A	to	B	C	to	D
Instantaneous flow	L/min	10, 50, 100 L/min	40	to	4000	-200	to	4200
		25 L/min	32	to	4000			
	cfm	10, 25, 50, 100 L/min	40	to	4000			
Accumulated flow	L	10 L/min	0	to	999999999	0	to	999999999
		25, 50, 100 L/min						
	Ft <sup>3</sup>	10, 25, 50 L/min						
		100 L/min						



•Command value (PD\_OUT)

Target	Units	Range	Rated control flow range			Set controlled flow rate range		
			Min.	to	Max.	Min.	to	Max.
Instantaneous flow	L/min	10 L/min	0.10	to	10.00	0.04	to	10.30
		25 L/min	0.2	to	25.0	0.1	to	25.8
		50 L/min	0.5	to	50.0	0.2	to	51.5
		100 L/min	1.0	to	100.0	0.4	to	103.0
	cfm	10 L/min	0.004	to	0.353	0.002	to	0.364
		25 L/min	0.009	to	0.883	0.004	to	0.909
		50 L/min	0.02	to	1.77	0.01	to	1.82
		100 L/min	0.04	to	3.53	0.02	to	3.64

Target	Units	Range	PD value					
			Rated control flow range			Set controlled flow rate range		
			A	to	B	E	to	F
Instantaneous flow	L/min	10, 50, 100 L/min	40	to	4000	16	to	4120
		25 L/min	32	to	4000			
	cfm	10, 25, 50, 100 L/min	40	to	4000			

Flow rate measurement (PD)

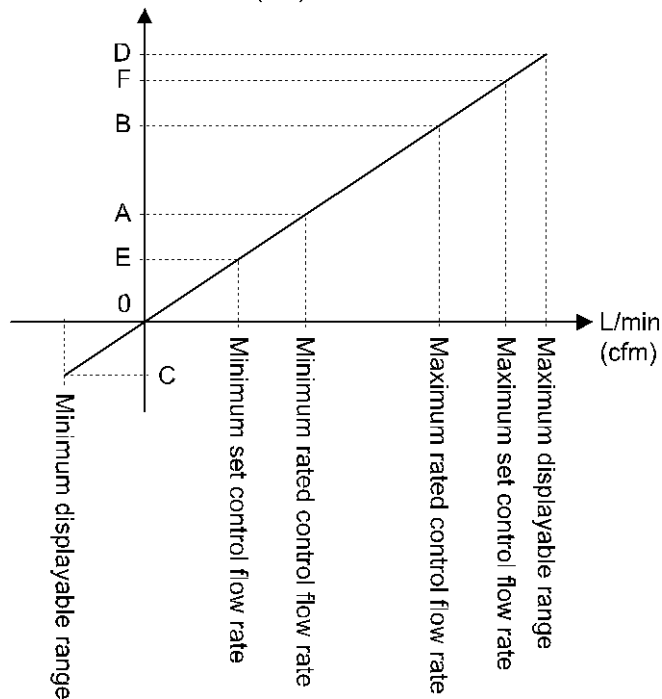

○ Conversion formula for process data and measurement/command value

**(1) Conversion formula for process data to measurement/command value:**  $Pr = a \times (PD) + b$

**(2) Conversion formula for measurement/command value to process data:**  $(PD) = (Pr - b) / a$

Pr: Measurement value and command value

PD: Measurement value (process data)

A: Inclination

B: Intercept

[Inclination and intercept to the units specification]

Target	Units	Range	Inclination a	Intercept b
Instantaneous flow	L/min	10 L/min	0.0025	0
		25 L/min	0.00625	0
		50 L/min	0.0125	0
		100 L/min	0.025	0
	cfm	10 L/min	0.000088275	0
		25 L/min	0.000220725	0
		50 L/min	0.0004415	0
		100 L/min	0.00088275	0
Accumulated flow	L	10 L/min	0.1	0
		25, 50, 100 L/min	1	0
	Ft <sup>3</sup>	10, 25, 50 L/min	0.01	0
		100 L/min	0.1	0

[Calculation example]

**(1) Conversion for process data to flow rate measurement/command value**

**(Range: 10 L/min; units specification: L/min; PD = 500)**

$$\begin{aligned}
 Pr &= a \times (PD) + b \\
 &= 0.0025 \times 500 + 0 \\
 &= 1.25[\text{L/min}]
 \end{aligned}$$

**(2) Conversion for flow rate measurement/command value to process data**

**(Range: 100 L/min; units specification: cfm; Pr = 2.0[cfm])**

$$\begin{aligned}
 (PD) &= (Pr - b) / a \\
 &= [2.0 - (0)] / (0.00088275) \\
 &= 2266
 \end{aligned}$$

## ■ IO-Link parameter settings

### ○ IODD file

IODD (I/O Device Description) is a definition file which provides all properties and parameters required for establishing functions and communication of the device.

The IODD includes the main IODD file and a set of image files such as vendor logo, device picture and device icon.

The IODD file for this product is as follows:

Product number	IODD file *
PFCA7**_**_**_**_**_**	SMC-PFCA7**_**_**_**_**_**-yyyymmdd-IODD1.1

\*: "\*" indicates the product model which corresponds to each IODD file.

\*: "yyyymmdd" indicates the date of creation of the file, with yyyy, mm, and dd representing the year, month, and date, respectively.

The IODD file can be downloaded from the SMC website (<https://www.smcworld.com>).

### ○ Service data

The tables below indicate the parameters which can be read or written by simple access parameter (direct parameters page) and ISDU parameters which are applicable to various parameters and commands.

#### ● Direct parameters page 1

DPP1 address	Access	Parameter name	Default (decimal number)	Description
0x07	R	Vendor ID	0x0083 (131)	"SMC Corporation"
0x08				
0x09	R	Device ID	0x0263 (611)	PFCA710-xx-1x-xxx
0x0A			0x0264 (612)	PFCA710-xx-2x-xxx
			0x0265 (613)	PFCA725-xx-1x-xxx
			0x0266 (614)	PFCA725-xx-2x-xxx
0x0B			0x0267 (615)	PFCA750-xx-1x-xxx
	0x0268 (616)	PFCA750-xx-2x-xxx		
	0x0269 (617)	PFCA711-xx-1x-xxx		
	0x026A (618)	PFCA711-xx-2x-xxx		

•ISDU parameters

Index (decimal number)	Subindex	Access *1	Parameter	Initial value	Note
0x0002 (2)	0	W	System command	-	Refer to "System command". (Page 61)
0x000C (12)	0	R/W	Device access lock	0x0000	Refer to "Device access lock parameter". (Page 61)
0x0010 (16)	0	R	Vendor name	SMC Corporation	
0x0011 (17)	0	R	Vendor text	www.smcworld.com	
0x0012 (18)	0	R	Product name	Example PFCA710-xx-1x-xxx	
0x0013 (19)	0	R	Product ID	Example PFCA710-xx-1x-xxx	
0x0014 (20)	0	R	Product text	Flow controller	
0x0015 (21)	0	R	Serial number	Example "xxxxxxxx"	•Indicated in 8 digits •16 octets fixed character string
0x0016 (22)	0	R	Hardware version	HW-Vx.y	x: Major revision number y: Minor revision number
0x0017 (23)	0	R	Software version	FW-Vx.y	x: Major revision number y: Minor revision number
0x0018 (24)	0	R/W	Application specific tag	ALL "*"	Can be changed arbitrarily
0x0024 (36)	0	R	Device status parameter	-	Refer to "Device status parameter". (Page 61)
0x0025 (37)	0	R	Detailed device status parameter	-	Refer to "Device details status parameter". (Page 62)
0x0028 (40)	0	R	Process data input	-	The latest process data can be read.
0x0029 (41)	0	R	Process data output	-	The latest process data can be read.

\*1: R: Read; W: Write

- System command (Index 2)

In the ISDU index 0x002 SystemCommand (system command), the command shown in the table below will be issued.

The button for each system command is displayed on the IO-Link setting tool (excluding "ParamDownloadStore").

Click the button to send the system command to the product.

Writeable commands are shown below.

Data type: 8 bit UInteger

Value	Definition of status	Description
128	Device Reset	Restart the device
129	Application Reset	Reset the peak/bottom value Reset the accumulated flow value
130	Restore Factory Reset	Reset of a set value to the factory default value
160	Zero Clear	Zero-clear
170	Peak Bottom Reset	Reset of the peak/bottom value
190	Accumulate Reset	Reset of the accumulated flow value

- Device access lock parameter (Index 12)

The conditions for device access lock are as follows.

Data type: 16 bit Record

Value	Description
0	Key lock release, DS lock release (initial value)
2	Key lock release, DS lock
8	Key lock, DS lock release
10	Key lock, DS Lock

**[Key-lock]**

Function that prevents changes to the flow controller settings (disables button operations).

When the keys are locked, setting changes or restoration of data storage (rewriting of parameter settings) through communication can still be performed.

**[Lock data storage (DS lock)]**

When the "Data storage" is locked, the data storage function of the flow controller is disabled.

In this case, access is rejected for data storage backup and restore.

- Device status parameter (Index 36)

The readable device statuses are as follows.

Data type: 8 bit UInteger

Value	Definition of status	Description
0	Normal operation	-
1	Maintenance is required	Not available
2	Out of spec.	Event category: Warning
3	Function check	Not supported
4	Failure or problem	Event category: Error

●Device details status parameter (Index 37)

Event details of the readable device statuses are as follows.

Layout	Event	Event class		Event code
		Definition	Value	
1	Internal failure or problem	Error	0xF4	0x8D03
2	Internal failure or problem	Error	0xF4	0x8D04
3	Internal failure or problem	Error	0xF4	0x8D05
4	Internal failure or problem	Error	0xF4	0x8D01
5	Internal failure or problem	Error	0xF4	0x8D06
6	Internal failure or problem	Error	0xF4	0x8D0C
7	Internal failure or problem	Error	0xF4	0x8D0D
8	Internal failure or problem	Error	0xF4	0x8D08
9	Shielding error	Error	0xF4	0x8D09
10	Control error	Error	0xF4	0x8D0A
11	Abnormal power supply voltage	Error	0xF4	0x8D0B
12	Above the accumulated flow measurement	Warning	0xE4	0x8D80
13	Outside the output PD setting range	Warning	0xE4	0x8D90
14	Above the instantaneous flow measurement	Warning	0xE4	0x8C10
15	Below the instantaneous flow measurement	Warning	0xE4	0x8C30
16	Test event A	Warning	0xE4	0x8CA0
17	Test event B	Warning	0xE4	0x8CA1
18	Data storage upload request	Notification	0x54	0xFF91

●Product original parameter

Index		Sub index	Access *1	Parameter	Data type *2	Initial value	Data storage *3	Setting value *4	Remarks
dec	hex								
1000	0x03E8	0	R/W	Units (Units setting)	U8	0	Y	0: L/min (L) 1: cfm (ft <sup>3</sup> )	When the units selection function is not available, read/write to an unselectable item is rejected.
1010	0x03F2	0	R/W	CoL (Display colour selection)	U8	1	Y	0: white (Always white characters) 1: 1onBoFFR (Blue background at on) 2: 1onRoFFB (Red background at on) 3: 1onGoFFR (Green characters at on) 4: 1onGoffR (Red characters at on)	Display colour setting
1020	0x03FC	0	R/W	NorP (Selection of switch output PNP/NPN)	U8	1	Y	0: NPN 1: PNP	Setting of the switch output specifications
1060	0x0424	0	R/W	FLU (Fluid)	U8	0	Y	0: Air (Air) 1: Argon (Argon) 2: CO <sub>2</sub> (Carbon dioxide)	
1070	0x042E	0	R/W	rEF (Reference condition)	U8	0	Y	0: STD (Standard condition) 1: NOR (Normal condition)	Reference condition setting
1210	0x04BA	0	R/W	OUT1_mode (Selection of OUT1 output mode)	U8	0	Y	0: Tolerance (Limit deviation tolerance) 1: Accum(P) (Accumulated output normal) 2: Accum(N) (Accumulated output reverse) 3: Pu1se(N) (Accumulated pulse normal) 4: P1use(P) (Accumulated pulse reverse) 5: Alarm(NC) (Error output) 6: AlwaysOFF (Output OFF)	Setting of OUT1 output mode
7210	0x1C2A	1	R/W	ToL1 (Setting of OUT1 limit deviation tolerance)	U16	3	Y	Setting range 0 to 50	
		2	R/W	On Delay1 (OUT1 on-delay time)	U16	0	Y	Setting range 0 to 6000	Set the OUT1 on-delay time 10 ms unit
		3	R/W	Off Delay1 (OUT1 off-delay time)	U16	0	Y	Setting range 0 to 6000	Set the OUT1 off-delay time 10 ms unit
1300	0x0514	0	R/W	OUT1_AC_L (Accumulated threshold value setting L)	U32	0	Y	Setting range 0 to 99999999	Unit specification when (Unit): "L/min" is selected
1310	0x051E	0	R/W	OUT1_AC_ft <sup>3</sup> (Accumulated threshold value cfm)	U32	0	Y	Setting range 0 to 99999999	Unit specification when (Unit): "cfm" is selected
1600	0x0640	0	R/W	Inc_Dec (Accumulation direction setting)	U8	0	Y	0: Increment (Addition) 1: Decrement (Subtraction)	
2000	0x07D0	1	R/W	Line name ON/OFF (Line name display)	U8	0	Y	0: OFF 1: ON	
		2	R/W	Sub display (Sub display setting)	U8	0	Y	0: Set value 1: Peak/Bottom 2: Accumulate valu 3: IO-Link mode 4: Line name	

●Product individual parameters (continued)

Index		Sub index	Access *1	Parameter	Data type *2	Initial value	Data storage *3	Setting value *4	Remarks	
dec	hex									
2010	0x07DA	0	R/W	drE (Display resolution setting)	U8	1	Y	0: High (1000 resolution) 1: Low (100 resolution)	Display resolution setting (The 10 L/min type and 100 L/min type only)	
2020	0x07E4	0	R/W	Rotation (Display rotation angle setting)	U8	0	Y	0: 0 deg 1: 90 deg 2: 180 deg 3: 270 deg		
2060	0x080C	0	R/W	Brightness (Display brightness setting)	U16	10	Y	Setting range 1 to 10	10% unit	
2100	0x0834	0	R/W	AOUT_Type (Analogue output settings)	U8	0	Y	0: 1-5V 1: 0-10V	Setting of analogue output (Voltage output type only)	
2110	0x083E	0	R/W	AOUT_Freespan (Analogue output free range setting value)	U16	4000	Y	Setting range 400 to 4200		
2200	0x0898	0	R/W	AC_Save (Accumulated flow value hold setting)	U8	0	Y	0: oFF (Not to hold) 1: 2 min 2: 5 min		
2220	0x08AC	0	R/W	AC_Shut (Automatic accumulation shut-off enable/disable setting)	U8	0	Y	0: Disable 1: Enable		
2310	0x0906	0	R/W	PD_invalid (Output PD setting at communication error)	U8	0	Y	0: Shut off 1: Keep last		
2320	0x0910	0	R/W	Control_Select (Control selection setting)	U8	0	Y	0: Remote 1: Local		
2330	0x091A	0	R/W	Local_Response (Setting of the timing to enable the local flow rate setting value)	U8	0	Y	0: At set 1: Direct		
2340	0x0924	0	R/W	Contorl_Start (Time to start local control operation)	U16	0	Y	Setting range 0 to 60	1 s increments	
2350	0x092E	0	R/W	Local_value (Local flow rate setting value)	U16	0	Y	Setting range 0 to 4120	The unit is a PD value	
2400	0x0960	0	R/W	diSP (Display OFF setting)	U8	0	Y	0: ON 1: OFF		
2410	0x096A	1	R/W	PIN code PIN valid (Used/Not used PIN code)	U8	0	Y	0: invalid 1: valid		
		2	R/W		PIN code (PIN code setting)	U16	0	Y	Setting range 0 to 999	
2420	0x0974	1	R/W	Line name	1st character (Left end)	U8	65	Y	Setting range 32 to 126	
		2	R/W		2nd character	U8	65	Y		
		3	R/W		3rd character	U8	65	Y		
		4	R/W		4th character	U8	65	Y		
		5	R/W		5th character	U8	65	Y		
		6	R/W		6th character	U8	65	Y		
		7	R/W		7th character	U8	65	Y		



●Product individual parameters (continued)

Index		Sub index	Access *1	Parameter	Data type *2	Initial value	Data storage *3	Setting value *4	Remarks
dec	hex								
10000	0x2710	0	R	Work_hour (Operation time)	U32	-	N	0 to 876000	Returns the current operation time [h].
7000	0x1B58	0	W	OUT Test (Output check)	U8	0	N	0: Normal output 1: Fixed output	Sets the bit in the PD to 1 when a fixed output is received.
7010	0x1B62	0	W	Toggle (Toggle output)	U8	-	N	0: Accumulated measurement value 1: Flow rate measurement value 16: OUT1 hardware 32: Accumulated flow SW 33: Limit deviation tolerance SW 80: Analogue output 160: Control selection 208: Flow rate display unit 209: Flow rate reference condition 210: Automatic accumulation shut-off 224: Accumulation diagnosis 225: Flow rate diagnosis 226: Output PD diagnosis 254: Error 255: System error	
7100	0x1BBC	0	R	Analogue output value	U16	-	N	Output voltage: 0.1 V increments Current output: 1 mA increments	The current analogue output value is returned.
8000	0x1F40	0	R	Inclination of flow rate PD a	F32	-	N	Refer to table "Inclination and intercept to the units specification". (Page 58)	
8010	0x1F4A	0	R	Flow rate PD intercept b	F32	-	N	Refer to table "Inclination and intercept to the units specification". (Page 58)	
8020	0x1F54	0	R	Flow rate peak value	S16	-	N	-200 to 4200	The conversion method from the communication value to the actual measurement value is the same as the method for process data.
8030	0x1F5E	0	R	Flow rate bottom value	S16	-	N		
8060	0x1F7C	0	R	Accumulation PD inclination a	F32	-	N	Refer to table "Inclination and intercept to the units specification". (Page 58)	
8070	0x1F86	0	R	Accumulation PD intercept b	F32	-	N	Refer to table "Inclination and intercept to the units specification". (Page 58)	

\*1: R means Read and W means Write.

\*2: Refer to table below for symbols.

Symbol	Data type (IO-Link standard)	Data length Bit[byte]	Description
U8	UIntegerT	8[1]	Unsigned integer
U16		16[2]	
S16	IntegerT	16[2]	Signed integer
F32	Float32T	32[4]	Floating point number
C32	StringT	32[4]	Character string

\*3: "Y" indicates that the parameter setting data is saved to the master, and "N" indicates that the parameter is not saved.

\*4: Read/write to unselectable items will be rejected depending on the product No.

## Troubleshooting

If a product operation failure occurs, please confirm the cause of the problem from the following table. If a cause applicable to the problem cannot be identified and normal operation can be recovered by replacement with a new product, this indicates that the product itself was faulty. Problems with the product may be due to the operating environment (network configuration, etc.). Please consult SMC.



### ○Troubleshooting list

Problem	Possible cause	Investigation method	Countermeasures
The display turns off Part of the display is missing	Incorrect power supply	Check if the power supply voltage is within 21.6 to 26.4 VDC.	Supply the power supply voltage of 21.6 to 26.4 VDC.
	Incorrect wiring	Check the power supply wiring. Check if the brown and blue wires are connected to DC(+) and DC(-) respectively, and if the wiring is secure.	Check and correct the wiring.
	Display OFF mode	Check the setting to see if display OFF mode is selected.	Set up the product again. (Page 21)
	Lead wire is broken		Replace the lead wire.
	The product failed		Replace the product.

Problem	Possible cause	Investigation method	Countermeasures
<p>Flow does not start</p> <p>Flow is unstable</p> <p>The control accuracy does not meet the specifications</p>	Entry of foreign matter	Check for foreign matter entry or sticking to the piping port.	Use a filter to prevent foreign matter from entering or sticking. Discharge the condensate of the filter periodically.
	Piping in the reverse direction	Check the fluid direction.	Mount the product so that the fluid flow direction is the same as the arrow indicated on the product label.
	Air leakage	Check if air is leaking from the piping.	Rework the piping. If the tightening torque is exceeded, the mounting screws, brackets and the pressure switch may be damaged.
	Pressure fluctuation	Check if the pressure is fluctuating.	It is possible that pulsation is generated due to the characteristics of the compressor acting as the pressure source or the pump. Change to a pressure source with less fluctuation or install a tank which reduces the pressure fluctuation.
	Insufficient or excess pressure	Check if the pressure is within the product specification. Check any pressure loss in the piping or filter.	Use the product within the operating differential pressure and operating pressure range.
	Fluid and reference condition mismatch	Check to see if the fluid and reference condition are consistent with the operating conditions.	Set the fluid and reference condition according to the operating conditions.
	Insufficient warming-up time	Check the product operation after 10 minutes have passed after turning on the power.	After energizing, the display and output can drift. Allow the product to warm up for at least 10 minutes.
	The product failed		Replace the product.

Problem	Possible cause	Investigation method	Countermeasures
Analogue/switch output does not output  Analogue/switch output is unstable	Incorrect wiring	Check the output wiring. Check if the analogue output is connected to the white wire, the switch output (in SIO mode) is connected to the black wire, and that the wire is not loose.	Check and correct the wiring.
	Entry of foreign matter	Check for foreign matter entry or sticking to the piping port.	Use a filter to prevent foreign matter from entering or sticking. Discharge the condensate of the filter periodically.
	Incorrect NPN or PNP specification	Check the output switch setting for the switch output NPN or PNP.	Select the switch output according to the operating conditions.
	Lead wire is broken		Replace the lead wire.
	The product failed		Replace the product.
Analogue input not accepted  Analogue input is incorrect	Incorrect wiring	Check the output wiring. Check if the analogue input is connected to the grey wire or that the wiring is not loose.	Check and correct the wiring.
	Contact resistance (for analogue voltage input type)	Check to see if there is any defective contact.	Connect the wire without defective contact.
	Lead wire is broken		Replace the lead wire.
	Wire is broken inside the product		Replace the product.
Buttons do not work	Key-lock mode is activated	Check if the key-lock function is turned on.	Deactivate key-lock mode. (Page 51)
	Button failure		Replace the product.
The units cannot be selected	Model selection (model selected does not have units selection function)	Check that the product No. printed on the product is equipped with units selection function.	Units selection function is not available for models which are fixed to SI units. *: The units selection function is not for use in Japan due to a new measurement law. *: Fixed SI unit: L/min
The mode does not shift to IO-Link mode while using IO-Link communication	IO-Link enable/disable setting is set to Disable	Check the IO-Link enable/disable setting.	Set the IO-Link enable/disable setting to Enable.
The mode shifts to IO-Link mode when not using IO-Link communication	Erroneous detection due to noise	Check the possible application of noise or if there is a noise source.	Remove the noise and noise source. Set the IO-Link enable/disable setting to Disable.

○ Troubleshooting list (IO-Link communication function)

Problem	Displayed content	Problem possible causes	Investigation method	Countermeasures
IO-Link indicator light: Off	-	Incorrect wiring	Check the connection of the connector.	Correct the cable wiring.
	-	Power supply error to the IO-Link master	Check the power supply voltage to the IO-Link master.	Supply 24 VDC±10% to the IO-Link master
IO-Link indicator light: 	-	Failure of the IO-Link wiring which is not in use	Check the connection and cable condition of the IO-Link cable.	Additionally tighten the IO-Link cable. (Replace the cable if it is broken.)
		IO-Link master and product version are not matched	Check the IO-Link version of the master and device.	Match the master IO-Link version to the device. *1
		Communication mode is not transferred to the Operation mode.	Check the setting of the data storage access lock and data storage backup level of the master.	Release the data storage access lock. Or deactivate the setting of the data storage backup level of the master port.
Data is swapped by byte	-	Program data assignment is incorrect	Check that the Endian type on the master upper level communication transmission format is Big Endian type or Little Endian type.	Assign the program data based on the Endian type of the transmission format of the master upper level communication. Or set to the master byte swap setting. (Refer to page 55 for the Endian type of the upper level communication.)





\*1: When the product is connected to the IO-Link master with version "V1.0", an error will be generated.



## ■ Warning/Error display

This function is to display error location and content when a problem or error has occurred.





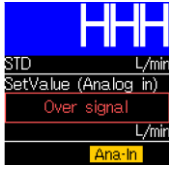

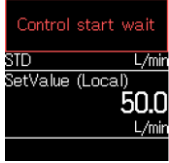
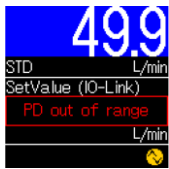
\*: If the error cannot be reset after the following measures are taken, or errors other than the following are displayed, please contact SMC for further investigation.

### ○ Warning display

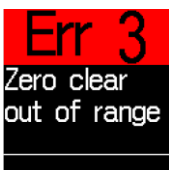

Warning name	Warning display	Description	Measures	Control operation in the event of an error
Above the instantaneous flow measurement (HHH)		A flow rate exceeding the upper limit of the displayable range is applied.	Check that the flow is within the product specification.	Continuing
Below the instantaneous flow measurement (LLL)		A flow rate below the lower limit of the displayable range is applied.	Mount the product so that the fluid flow direction is the same as the arrow indicated on the side of the body.	Continuing
Above the accumulated flow measurement (Reached accum max) (Reached accum low)		The accumulated value exceeded the accumulated flow range. (For accumulated increment)	Reset the accumulated flow. (Press and hold the SET and DOWN buttons simultaneously for <u>1 second or longer.</u> )	Continuing
		The accumulated value has reached the set accumulated value. (For accumulated decrement)		Continuing
Automatic accumulation shut-off (Automatic shutoff)		The control operation has stopped because the accumulated value reached the set value. (When automatic accumulation shut-off is enable)	Reset the accumulated flow. (Press and hold the SET and DOWN buttons simultaneously for <u>1 second or longer.</u> )	Stopped

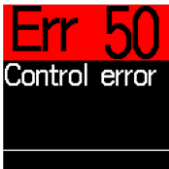
Warning name	Warning display	Description	Measures	Control operation in the event of an error
Analogue input warning (Over signal) (No signal)		Analogue input has exceeded 110%F.S. of the rated control flow range.	Make sure that the analogue input is within the set flow rate range.	Continuing
		Analogue input is below -5%F.S. of the rated control flow range.		Continuing
Waiting for the start of local control operation (Control start wait)		Stand-by state until the mode shifts to measurement mode after the power is turned on. (When [Local] is selected in the control selection setting mode)	Start the operation of the product after the stand-by time has elapsed.	Stop
Outside the output PD range (PD out of range)		The output PD of the commanded flow rate is beyond the range of 0 to 4120.	Make sure the output PD of the commanded flow rate is within the range of 0 to 4120.	Value before the event

○Error display

Error name	Error display	Description	Measures	Control operation in the event of an error
System error (Err0, 4, 6, 8, 16, 40, 82, 83)		An internal data error has occurred.	Turn off the power and check for any noise source, and then turn on the power again. If the failure cannot be solved, contact SMC.	Stop
Over current error (Err1)		The switch output load current has exceeded 80 mA.	Remove the cause of the excessive current in the output.	Continuing
Zero clear error (Err3)		During a zero clear operation, a flow rate exceeding $\pm 5\%$ F.S. is applied.	Perform the zero-clear operation again when the flow rate is not applied.	Continuing
Version does not match (Err15)		The IO-Link version does not match with the master.	Align the master IO-Link version to the device.	Continuing
Control error (Err50)	  *: When [Local] is selected	The controlled flow rate does not continuously reach the commanded flow rate <u>for at least 5 seconds</u> .	Use the product within the operating differential pressure and operating pressure range. Check to see if there is any air leakage from piping, etc. The controlled flow rate is restored by setting the commanded flow rate to zero. When [Local] is selected in control selection setting mode, the controlled flow rate is restored by pressing and holding the UP and DOWN button <u>for 1 second or longer</u> .	Stopped



Error name	Error display	Description	Measures	Control operation in the event of an error
Close error (Err51)		A flow rate exceeding $\pm 5\%$ F.S. is applied when the commanded flow rate is less than $\pm 1\%$ F.S.	Check the installation so that the direction of fluid flow is the same as the direction of the arrow shown on the side of the unit and switch the power on again.	Stopped
Abnormal power supply voltage (Err60)		The power supply voltage is outside of the range $24 \text{ VDC} \pm 10\%$ .	Supply a power supply voltage within the range $24 \text{ VDC} \pm 10\%$ .	Stopped

# Specifications

Model		PFCA710	PFCA725	PFCA750	PFCA711	
Fluid	Applicable fluids *1	Dry air/N <sub>2</sub> /Ar/CO <sub>2</sub> (Air quality: JIS B8392-1 1.6.2, ISO8573-1 1.6.2)				
	Fluid temperature range	0 to 50 °C				
Flow spec.	Detection method		Heating type sensor			
	Rated control flow range *2	Dry air, N <sub>2</sub> , Ar	0.1 to 10 L/min	0.2 to 25 L/min	0.5 to 50 L/min	1 to 100 L/min
		CO <sub>2</sub>	0.1 to 5 L/min	0.2 to 12.5 L/min	0.5 to 25 L/min	1 to 50 L/min
	Set controlled flow rate range *2	Dry air, N <sub>2</sub> , Ar	0.04 to 10.3 L/min	0.1 to 25.8 L/min	0.2 to 51.5 L/min	0.4 to 103 L/min
		CO <sub>2</sub>	0.04 to 5.15 L/min	0.1 to 12.9 L/min	0.2 to 25.8 L/min	0.4 to 51.5 L/min
	Min. unit of set controlled flow rate		0.01 L/min	0.1 L/min		
	Set accumulated flow range		0.0 to 99,999,999.9 L	0 to 999,999,999 L		
	Min. unit of accumulated flow rate		0.1 L	1 L		
	Accumulated volume per pulse (Pulse width = 50 ms)		0.1 L/Pulse			1 L/Pulse
	Accumulated-value hold function		Select from every 2 or 5 minutes (when the function is not set, power supply OFF reset)			
Control spec. *3	Control accuracy		±3%F.S.			
	Analog output accuracy *4		±3%F.S.			
	Repeatability		±1%F.S.			
	Temperature characteristics		±5%F.S. (0 to 50 °C, Reference: 25 °C)			
	Pressure characteristics		±2%F.S. (Operating pressure range, reference operating pressure)			
	Settling time		Reaches within ±3%F.S. of the commanded flow rate in 0.5 seconds or less (Under reference conditions) *5		Reaches within ±3%F.S. of the commanded flow rate in 1 second or less (Under reference conditions) *5	
	Control spec. method		IO-Link, local setting, analogue input			
	Operation when power supply is disconnected		Fully closed (Normally closed (N.C.))			
Analogue input	Voltage	Input type	1 to 5 V			
		Input impedance	1 MΩ approx.			
	Current	Input type	4 to 20 mA			
		Input impedance	250 Ω or less			
Analogue output	Voltage	Output type	Select from 1 to 5 V or 0 to 10 V			
		Output impedance	1 kΩ approx.			
	Current	Output type	4 to 20 mA			
		Load impedance	50 to 600 Ω			

Model		PFCA710	PFCA725	PFCA750	PFCA711	
Switch output	Output type	Select from NPN or PNP open collector output				
	Output mode	Limit deviation tolerance mode, accumulated output, accumulated pulse output, error output, switch output off				
	Switch operation	Select from normal output or reversed output				
	Max. load current	80 mA				
	Max. applied voltage (Only NPN)	30 VDC				
	Internal voltage drop (Residual voltage)	1.5 V or less (at 80 mA load current)				
	Delay time	5 ms or less, variable from 0 to 60 s/0.01 s increments				
	Protection	Switch output power supply polarity protection, over current protection				
Pressure spec.	Operating pressure range *6	50 to 250 kPa	100 to 300 kPa	150 to 300 kPa	250 to 350 kPa	
	Min. operating differential pressure *7	50 kPa	100 kPa	150 kPa	250 kPa	
	Reference operating pressure *8	100 kPa	150 kPa	200 kPa	300 kPa	
	Proof pressure	1 MPa				
Electrical spec.	Power supply voltage	24 VDC±10%				
	Current consumption *9	200 mA or less				
	Protection	Power supply polarity protection				
Display	Reference condition *10	Select from standard condition (STD) and normal condition (NOR)				
	Display mode	Instantaneous flow rate display (Main display) Select from set control flow display and accumulated flow rate display (Sub display)				
	Unit *11	Instantaneous flow	L/min, cfm			
		Accumulated flow	L, ft <sup>3</sup>			
	Displayable range	Instantaneous flow	-0.5 to 10.5 L/min	-1.3 to 26.3 L/min	-2.5 to 52.5 L/min	-5 to 105 L/min
		Accumulated flow	0 to 99,999,999.9 L	0 to 999,999,999 L		
	Min. display units	Instantaneous flow	0.01 L/min	0.1 L/min		
		Accumulated flow	0.1 L	1 L		
Display *12	LCD (The display can be rotated by 90, 180, and 270°)					
Mounting orientation		The display cannot be mounted with the display facing down				
Environmental resistance	Enclosure rating	IP40				
	Withstand voltage	1000 VAC for 1 minute between terminals and housing				
	Insulation resistance	50 MΩ or more between terminals and housing (with 500 VDC megger)				
	Operating temperature range	Operation: 0 to 50 °C, Storage: -10 to 60 °C (no freezing or condensation)				
	Operating humidity range	Operation, storage: 35 to 85% R.H. (no freezing or condensation)				
Standard		CE/UKCA marked				
Piping	Piping spec.	C4 (φ4)/C6 (φ6)	C6 (φ6)/N7 (φ1/4")/C8 (φ8)			
	Screw fitting	01 (Rc1/8)/F1 (NPT1/8)/N1 (G1/8)			02 (Rc1/4)/F2 (NPT1/4)/N2 (G1/4)	
Materials in contact with fluid		PPS, FKM, SUS, Brass, PTFE, Si, Au, GE4F				
Weight	Product	One-touch fitting	255 g approx.			
		Screw fitting	305 g approx.			
	Lead wire	180 g approx.				
	Bracket	25 g approx.				

- \*1: Refer to the recommended pneumatic circuit.
- \*2: The operation may be unstable outside the rated control flow range.
- \*3: Applicable fluid: The specification value when dry air is shown. For gas types other than air, the value is for reference.
- \*4: For the analogue voltage, option 1, lead wire with M12 connector (3 m long), is used.  
If the lead wire is different, the accuracy may fluctuate depending on the wiring resistance.
- \*5: The reference conditions are as follows: pressure: reference operating pressure; temperature: 25 °C; commanded flow rate: step change from 1% to 100%.  
In other conditions, the setting time may be delayed.
- \*6: The operating pressure range refers to the pressure that can be applied to the primary side of the product. This product cannot be used for negative pressure.
- \*7: The minimum operating differential pressure is the minimum differential pressure value (pressure difference between the primary and secondary sides) required for the product to operate normally.  
Do not mount a restrictor immediately on the secondary side of the product. Doing so may result in unstable control operation.
- \*8: The pressure on the secondary side of the product is open to atmosphere (0 kPa).
- \*9: Analogue output and switch output are not included.  
If there is no supply pressure, a consumption current beyond the product specifications may flow in the event of an error in control operation.
- \*10: Standard condition (STD): 20 °C, 101.3 kPa, 65%R.H. (The flow rate given in the specification is the value at the standard condition)  
Normal condition (NOR): 0 °C, 101.3 kPa, 0%R.H.
- \*11: This setting is only available for models with the units selection function.  
For models without the units selection function, the instantaneous flow is L/min and the accumulated flow (rate) is fixed to L.
- \*12: The typefaces included herein are solely developed by DvnaComware Taiwan Inc.
- \*13: SMC are working to improve quality. However, any products with tiny scratches, smear, dead-pixel, or variation in the display colour or brightness which does not affect the performance of the product, are verified as conforming products.

○Cable specification of lead wire with M12 connector (ZS-53-A, ZS-53-D)

Item		Specification
Core	Nominal cross section	AWG21
Insulator	O.D.	1.60 mm approx.
Sheath	Material	Oil-resistant PVC
Outer diameter		φ6

## ■ Characteristics data

- Flow rate/Analogue input

Analogue input values are converted into corresponding commanded flow rates.

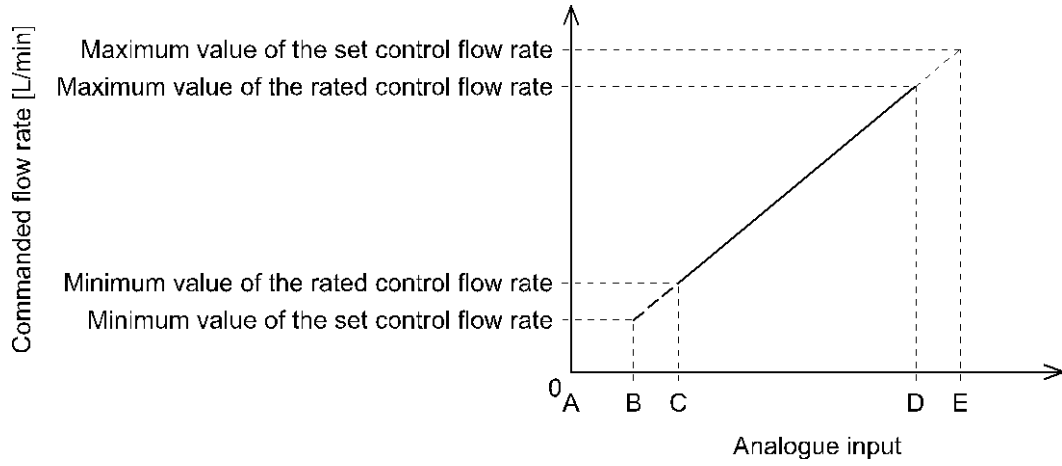

	A	B	C		D	E
			PFCA710/750/711	PFCA725		
Voltage input	1 V	1.016 V	1.04 V	1.032 V	5 V	5.12 V
Current input	4 mA	4.064 mA	4.16 mA	4.128 mA	20 mA	20.48 mA

●Flow rate/Analogue output

Analogue output is output according to the controlled flow rate.

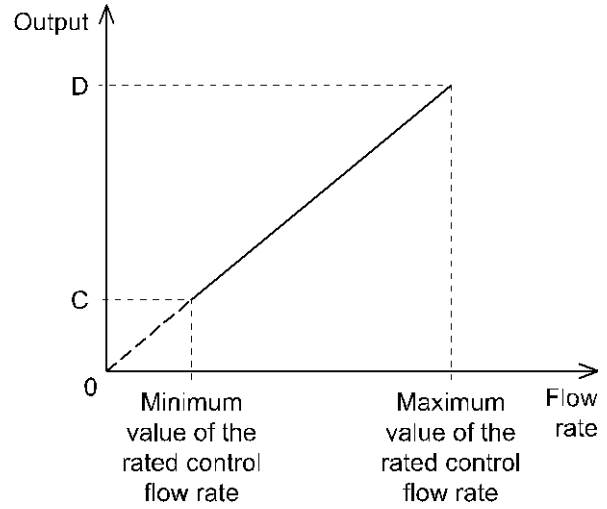
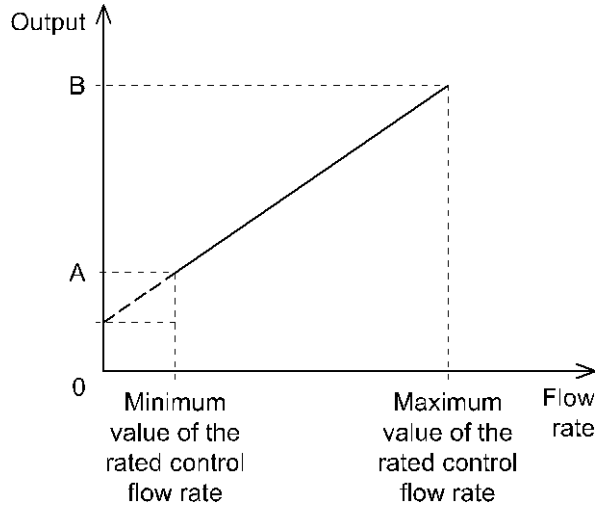

	0 L/min	A		B
		PFCA710/750/711	PFCA725	
Voltage output (1 to 5 V)	1 V	1.04 V	1.032 V	5 V
Current output	4 mA	4.16 mA	4.128 mA	20 mA

	0 L/min	C		D
		PFCA710/750/711	PFCA725	
Voltage output (0 to 10 V) <sup>*1</sup>	0 V	0.1 V	0.08 V	10 V

\*1: Set the current that flows from the connected equipment to the analogue output to 20  $\mu$ A or less when selecting 0 to 10 V. When more than 20  $\mu$ A current flows, it is possible that the accuracy will not be satisfied below 0.5 V.

Model	Min. value of the rated control flow rate	Max. value of the rated control flow rate
PFCA710	0.1 L/min	10.0 L/min
PFCA725	0.2 L/min	25.0 L/min
PFCA750	0.5 L/min	50.0 L/min
PFCA711	1.0 L/min	100.0 L/min

## ■Dimensions

PFCA7##-C4/C6/C8/N7

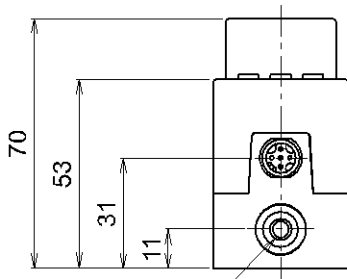
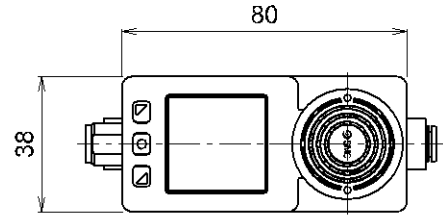

2 x  $\phi 6$  One-touch fitting

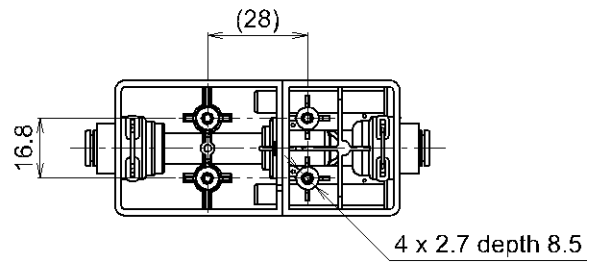
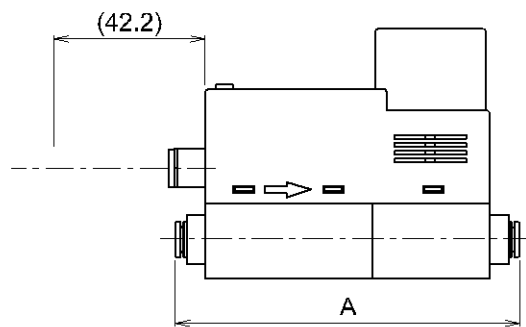

(mm)

Model	A
PFCA7##-C4	96.2
PFCA7##-C6	96.6
PFCA7##-C8	100
PFCA7##-N7	96.6

PFCA7##-#1/2

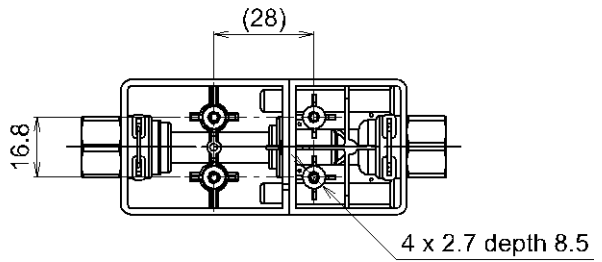
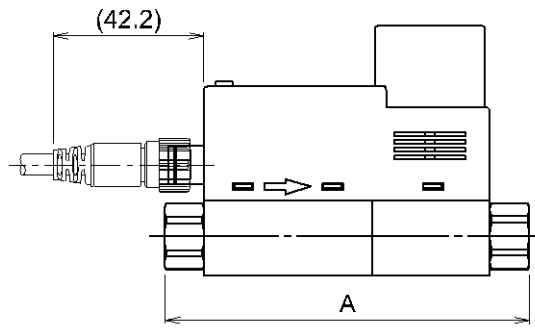
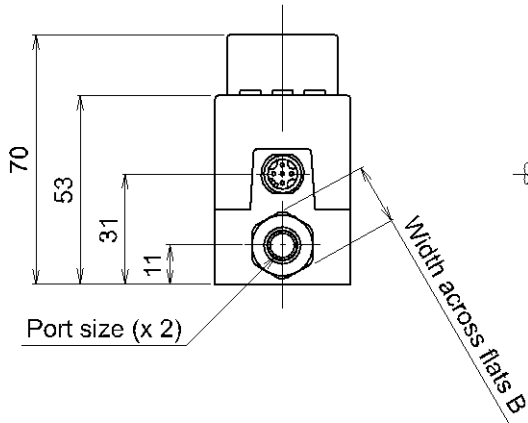
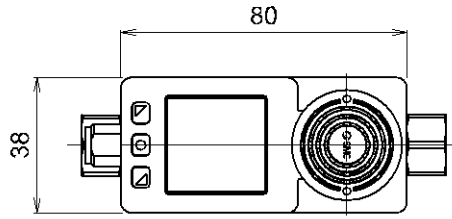

(mm)

Model	A	B
PFCA7##-01	102	17
PFCA7##-N1	102	17
PFCA7##-F1	102	17
PFCA7##-02	102	17
PFCA7##-N2	102	17
PFCA7##-F2	110	21



Bracket (ZS-40-L)

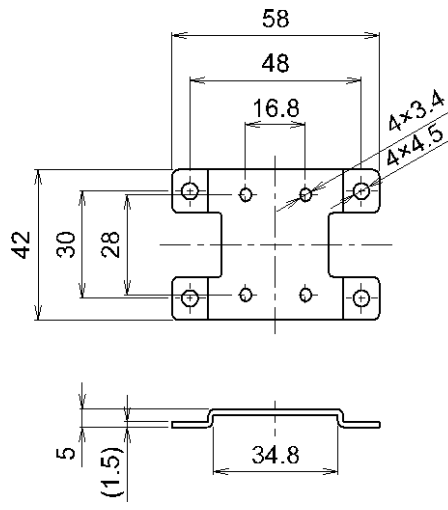

Bracket (ZS-53-G)

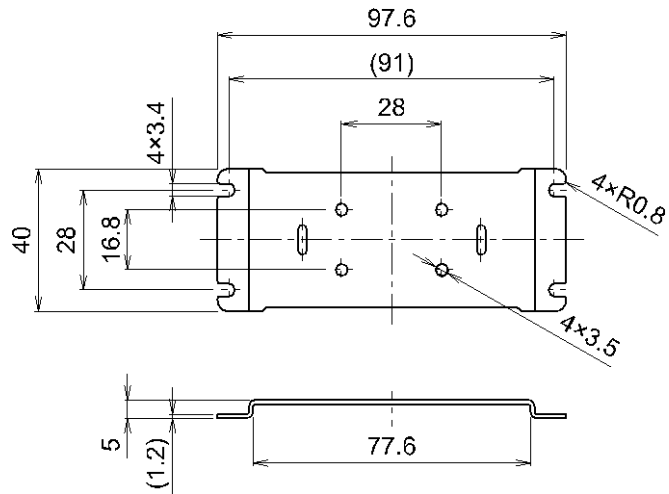

Lead wire with connector (ZS-53-A)

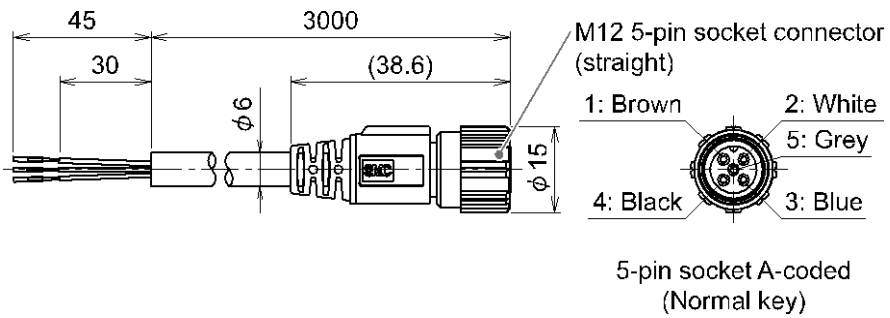

Lead wire with connector (ZS-53-D)

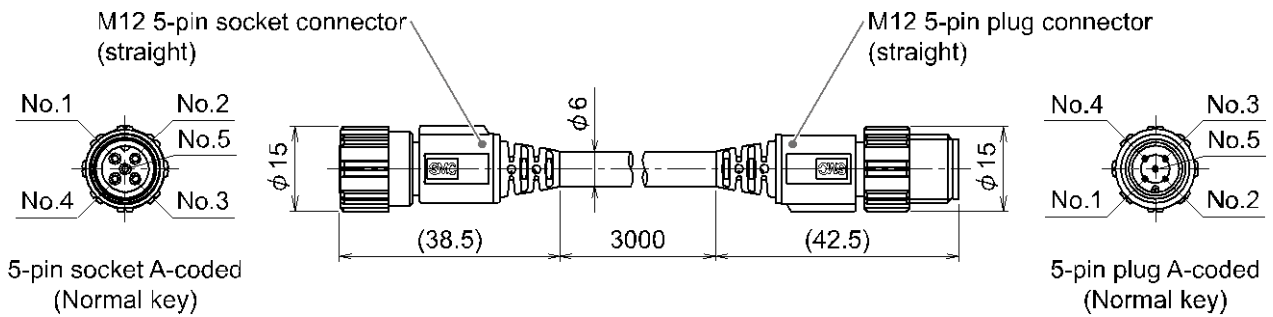

Revision history
A: Contents revised in several places. [June 2024]

# SMC Corporation

Tel: + 81 3 5207 8249 Fax: +81 3 5298 5362  
URL <https://www.smcworld.com>

---

Note: Specifications are subject to change without prior notice and any obligation on the part of the manufacturer.  
© SMC Corporation All Rights Reserved

