



Operation Manual

PRODUCT NAME

Digital Flow Switch
(Remote type sensor unit)

MODEL / Series / Product Number

PF2W5##

SMC Corporation

Table of Contents

Safety Instructions	3
Model Indication and How to Order	11
Summary of Product parts	13
Definition and terminology	14
Mounting and Installation	15
Installation	15
Piping	16
Wiring	18
Troubleshooting	22
Cross-reference for troubleshooting	22
Specification	23
Specifications	23
Characteristics data	25
Dimensions	26



Safety Instructions

These safety instructions are intended to prevent hazardous situations and/or equipment damage. These instructions indicate the level of potential hazard with the labels of “**Caution**,” “**Warning**” or “**Danger**.” They are all important notes for safety and must be followed in addition to International Standards (ISO/IEC)^{*)}, and other safety regulations.

*1) ISO 4414: Pneumatic fluid power - General rules and safety requirements for systems and their components
ISO 4413: Hydraulic fluid power - General rules and safety requirements for systems and their components
IEC 60204-1: Safety of machinery - Electrical equipment of machines - Part 1: General requirements
ISO 10218-1: Robots and robotic devices - Safety requirements for industrial robots - Part 1: Robots
etc.



Danger

Danger indicates a hazard with a high level of risk which, if not avoided, will result in death or serious injury.



Warning

Warning indicates a hazard with a medium level of risk which, if not avoided, could result in death or serious injury.



Caution

Caution indicates a hazard with a low level of risk which, if not avoided, could result in minor or moderate injury.



Warning

1. The compatibility of the product is the responsibility of the person who designs the equipment or decides its specifications.

Since the product specified here is used under various operating conditions, its compatibility with specific equipment must be decided by the person who designs the equipment or decides its specifications based on necessary analysis and test results. The expected performance and safety assurance of the equipment will be the responsibility of the person who has determined its compatibility with the product. This person should also continuously review all specifications of the product referring to its latest catalog information, with a view to giving due consideration to any possibility of equipment failure when configuring the equipment.

2. Only personnel with appropriate training should operate machinery and equipment.

The product specified here may become unsafe if handled incorrectly. The assembly, operation and maintenance of machines or equipment including our products must be performed by an operator who is appropriately trained and experienced.

3. Do not service or attempt to remove product and machinery/equipment until safety is confirmed.

1. The inspection and maintenance of machinery/equipment should only be performed after measures to prevent falling or runaway of the driven objects have been confirmed.
2. When the product is to be removed, confirm that the safety measures as mentioned above are implemented and the power from any appropriate source is cut, and read and understand the specific product precautions of all relevant products carefully.
3. Before machinery/equipment is restarted, take measures to prevent unexpected operation and malfunction.

4. Our products cannot be used beyond their specifications. Our products are not developed, designed, and manufactured to be used under the following conditions or environments. Use under such conditions or environments is not covered.

1. Conditions and environments outside of the given specifications, or use outdoors or in a place exposed to direct sunlight.
2. Use for nuclear power, railways, aviation, space equipment, ships, vehicles, military application, equipment affecting human life, body, and property, fuel equipment, entertainment equipment, emergency shut-off circuits, press clutches, brake circuits, safety equipment, etc., and use for applications that do not conform to standard specifications such as catalogs and operation manuals.
3. Use for interlock circuits, except for use with double interlock such as installing a mechanical protection function in case of failure. Please periodically inspect the product to confirm that the product is operating properly.



Safety Instructions

Caution

We develop, design, and manufacture our products to be used for automatic control equipment, and provide them for peaceful use in manufacturing industries.

Use in non-manufacturing industries is not covered.

Products we manufacture and sell cannot be used for the purpose of transactions or certification specified in the Measurement Act.

The new Measurement Act prohibits use of any unit other than SI units in Japan.

Limited warranty and Disclaimer/Compliance Requirements

The product used is subject to the following “Limited warranty and Disclaimer” and “Compliance Requirements”. Read and accept them before using the product.

Limited warranty and Disclaimer

1. The warranty period of the product is 1 year in service or 1.5 years after the product is delivered, whichever is first.*2)
Also, the product may have specified durability, running distance or replacement parts. Please consult your nearest sales branch.
2. For any failure or damage reported within the warranty period which is clearly our responsibility, a replacement product or necessary parts will be provided.
This limited warranty applies only to our product independently, and not to any other damage incurred due to the failure of the product.
3. Prior to using SMC products, please read and understand the warranty terms and disclaimers noted in the specified catalog for the particular products.

***2) Vacuum pads are excluded from this 1 year warranty.**

A vacuum pad is a consumable part, so it is warranted for a year after it is delivered.

Also, even within the warranty period, the wear of a product due to the use of the vacuum pad or failure due to the deterioration of rubber material are not covered by the limited warranty

Compliance Requirements

1. The use of SMC products with production equipment for the manufacture of weapons of mass destruction (WMD) or any other weapon is strictly prohibited.
2. The exports of SMC products or technology from one country to another are governed by the relevant security laws and regulations of the countries involved in the transaction. Prior to the shipment of a SMC product to another country, assure that all local rules governing that export are known and followed.

Operator

- ◆ This operation manual is intended for those who have knowledge of machinery using pneumatic equipment, and have sufficient knowledge of assembly, operation and maintenance of such equipment. Only those persons are allowed to perform assembly, operation and maintenance.
- ◆ Read and understand this operation manual carefully before assembling, operating or providing maintenance to the product.

■ Safety Instructions

Warning

- Do not disassemble, modify (including changing the printed circuit board) or repair.
An injury or failure can result.
- Do not operate the product outside of the specifications.
Do not use for flammable or harmful fluids.
Fire, malfunction, or damage to the product can result.
Verify the specifications before use.
- Do not operate in an atmosphere containing flammable, explosive or corrosive gas.
Fire or an explosion can result.
This product is not designed to be explosion proof.
- Do not use the product for flammable or highly permeable fluids.
A fire or explosion can result.
- Do not use the product in a place where static electricity is a problem.
Otherwise it can cause failure or malfunction of the system.
- If using the product in an interlocking circuit:
 - Provide a double interlocking system, for example a mechanical system
 - Check the product regularly for proper operationOtherwise malfunction can result, causing an accident.
- The following instructions must be followed during maintenance:
 - Turn off the power supply
 - Ensure the flow is shut off before performing maintenanceOtherwise an injury can result.

Caution

- Do not touch the terminals and connectors while the power is on.
Otherwise electric shock, malfunction or damage to the product can result.
- Do not touch the piping or its connected parts when the fluid is at high temperature.
It may lead to burnt.
Ensure the piping cools sufficiently before touching.
- After maintenance is complete, perform appropriate functional inspections and leak tests.
Stop operation if the equipment does not function properly or there is a leakage of fluid.
When leakage occurs from parts other than the piping, the product might be faulty.
Disconnect the power supply and stop the fluid supply.
Do not apply fluid under leaking conditions.
Safety cannot be assured in the case of unexpected malfunction.

■ NOTE

- Follow the instructions given below when designing, selecting and handling the product.
- The instructions on design and selection (installation, wiring, environment, adjustment, operation, maintenance, etc.) described below must also be followed.
- *Product specifications
 - Use the specified voltage.
Otherwise failure or malfunction can result.
Insufficient supply voltage may not drive a load due to a voltage drop inside the product.
Verify the operating voltage of the load before use.
 - Do not exceed the specified maximum allowable load.
Otherwise it can cause damage or shorten the lifetime of the product.
 - The applicable fluids are that the product for water is applicable for 0 to 50 °C and the product for high temperature fluid is applicable for 0 to 90 °C and ethylene glycol 50% solution (0 to 90 °C) with viscosity of 3 mPa·s (3 cP) or less.
Measurement accuracy is not guaranteed if other fluids are used.
Do not use fluids containing chemicals, synthetic oils, organic solvents, salt or corrosive gases.
Using such fluids can result in malfunction and damage to the product.
Check the details of the specifications before use.
 - Confirm the pressure loss at the sensor according to the pressure loss graph before designing piping.
Confirm detection condition of sensor electrified potential.
 - Consider measures to prevent over pressure due to water hammer.
<Measures to reduce water hammer>
 1. Install a water hammer relieving valve.
 2. Use a flexible material for piping (such as a rubber hose) and an accumulator that can absorb impact pressure.
 3. Keep piping as short as possible.
 - Use the specified measurement flow rate and operating pressure.
Otherwise it can cause damage to the product or inability to measure correctly.
 - Reserve a space for maintenance.
Allow sufficient space for maintenance when designing the system.

●Product handling

*Installation

- Tighten to the specified tightening torque.

If the tightening torque is exceeded the mounting screws and brackets may be damaged.

If the tightening torque is insufficient, the product may be displaced and the mounting screws may come loose.

(Refer to page 15 "Mounting and Installation".)

- Ensure that the FG terminal is connected to ground when using a commercially available switch-mode power supply.
- Do not drop, hit or apply excessive shock to the product.
Otherwise damage to the internal parts can result, causing malfunction.
- Do not pull the lead wire forcefully, or lift the product by pulling the lead wire. (Tensile force 49 N or less)
Hold the product body when handling, to prevent damage, failure or malfunction.
- The tensile strength of the power supply/output connection cable is 50 N and the sensor lead wire with a connector is 25 N.
- For piping of the product, hold the piping with a spanner on the metal part of the product (Piping attachment).
Holding other parts with spanner leads to may damage the product.
- Any dust left in the piping should be flushed out by air blow before connecting the piping to the product.
Otherwise damage or malfunction can result.
- Refer to the flow direction of the fluid indicated on the product label for installation and piping.
- Avoid piping in which the piping size of the IN side of the switch changes suddenly.
If the piping size is reduced sharply or there is a restrictor such as a valve on the IN side, fluid velocity distribution in the piping will be disturbed, leading to improper measurement.
Therefore, the above-mentioned piping should be connected on the OUT side.
If the OUT side is opened, or flow rate is excessive, cavitations may be generated, which may result in improper measurement.
As a measure against this, it is possible to reduce the cavitations by increasing the fluid pressure.
Take action such as mounting an orifice on the OUT side of the switch, and confirm that there is no malfunction before handling.
If the orifice of the OUT side is fully closed to operate the pump, the switch may malfunction due to the effect of pulsation (pressure fluctuation). Ensure that there is no malfunction before usage.
- Do not insert metal wires or other foreign matter into the piping port.
This can damage the sensor causing failure or malfunction.
- Never mount a product in a location that will be used as a foothold.
The product may be damaged if excessive force is applied by stepping or climbing onto it.
- If the fluid may contain foreign matter, install and connect a filter to the inlet.
The adherence of foreign matter to the vortex generator or detector can cause errors in measurement accuracy.
A filter of approx. 40 mesh is recommended.
- Design and install the application so that the fluid detection path is always full.
- If the product is mounted vertically, let the liquid flow from bottom to top.
Trapped air bubbles can cause errors in measurement accuracy.
(If the fluid detection path is always filled with liquid, there will be no problem.)

*Wiring

- Do not pull the lead wires.

In particular, never lift a product equipped with fitting and piping by holding the lead wires.

Otherwise damage to the internal parts can result, causing malfunction or disconnection of the connector.

- Avoid repeatedly bending or stretching the lead wire, or placing heavy loads on it.

Repeated bending stress or tensile stress can cause damage to the sheath, or breakage of the wires.

If the lead wire can move, fix it near the body of the product.

The recommended bend radius of the lead wire is 6 times the outside diameter of the sheath, or 33 times the outside diameter of the wire insulation material, whichever is larger.

Replace any damaged lead wire with a new one.

- Wire correctly.

Incorrect wiring can damage the product.

- Do not perform wiring while the power is on.

Otherwise damage to the internal parts can result, causing malfunction.

- Do not route wires and cables together with power or high voltage cables.

Otherwise the product can malfunction due to interference or noise and surge voltage from power and high voltage cables to the signal line. Route the wires (piping) of the product separately from power or high voltage cables.

- Confirm proper insulation of wiring.

Poor insulation (interference from another circuit, poor insulation between terminals, etc.) can lead to excess voltage or current being applied to the product, causing damage.

- Keep wiring as short as possible to prevent interference from electromagnetic noise and surge voltage.

Do not use a cable longer than 30 m.

Wire the DC(-) line (blue) as close as possible to the power supply.

- When analogue output is used, install a noise filter (line noise filter, ferrite element, etc.) between the switch-mode power supply and this product.

*Environment

- Do not use the product in an environment that is constantly exposed to the splash of water.
Otherwise failure or malfunction can result. Take measures such as using a cover.
- Do not use the product in an environment where corrosive gases or fluids could be splashed.
Otherwise damage to the product and malfunction can result.
- Do not use in a place where the product could be splashed by oil or chemicals.
If the product is to be used in an environment containing oils or chemicals such as coolant or cleaning solvent, even for a short time, it may be adversely affected (damage, malfunction, or hardening of the lead wires).
- Do not use in an area where electrical surges are generated.
If there is equipment generates large electrical surges (solenoid type lifter, high frequency induction furnace, motor, etc.) close to the product, damage or failure of the internal circuit may occur. Take measures against the surge sources, and prevent the wires from coming into close contact.
- Do not use a load which generates a surge voltage.
When a surge-generating load such as a relay or solenoid is driven directly, use a load with a built-in surge suppressor.
- The product is CE/UKCA marked, but not immune to lightning strikes. Take measures against lightning strikes in the system.
- Do not use the product in areas that are exposed to vibration or impact.
Otherwise failure or malfunction can result.
- Do not use the product in the presence of a magnetic field.
This may lead to the malfunction of the product.
- Prevent foreign matter such as wire debris from entering the product.
Otherwise failure or malfunction can result.
- Do not use the product in areas subject to large temperature cycle.
Heating/cooling cycles other than ordinary changes in temperature can adversely affect the internal structure of the product.
- Do not expose the product to direct sunlight.
If using in a location directly exposed to sunlight, use a suitable protective cover.
Otherwise failure or malfunction can result.
- Keep within the operating fluid temperature and operating temperatures range.
The operating fluid temperature range is 0 to 50 °C and the product for high temperature fluid is 0 to 90 °C, and operating temperature range is 0 to 50 °C.
If the fluid freezes, it may cause damage and malfunction of the switch, so please take measures to prevent freezing.
When a fluid at a lower temperature than the ambient temperature is supplied, the product can break due to condensation and malfunction. Keep the product from having condensation.
Please be aware that water droplets may cause early deterioration/damage, particularly if the product is installed vertically or upside-down.
Protection against freezing is necessary.
Avoid sudden temperature changes even within the specified temperature range.
- Do not operate close to a heat source, or in a location exposed to radiant heat.
Otherwise malfunction can result.

*Adjustment and Operation

- Connect load before turning the power supply on.
- Supply the power when there is no flow.
- If using the product to detect very small flow rates, warm up the product for 10 to 15 minutes first.
There will be a drift on the analogue output of approximate ± 2 to 3% immediately after the power supply is turn on, within 10 minutes.
- Check regulators and flow adjustment valves before introducing the fluid.
If pressure or flow rate beyond the specified range are applied to the sensor, the sensor unit may be damaged.
- Do not attempt to insert or pull the flow rate sensor or its connector when the power is on.
- The product is a flow meter using Karman vortex. The flow meter using Karman vortex has lower output frequency at excess flow state. Do not use the product within the excess flow area in the chart below.

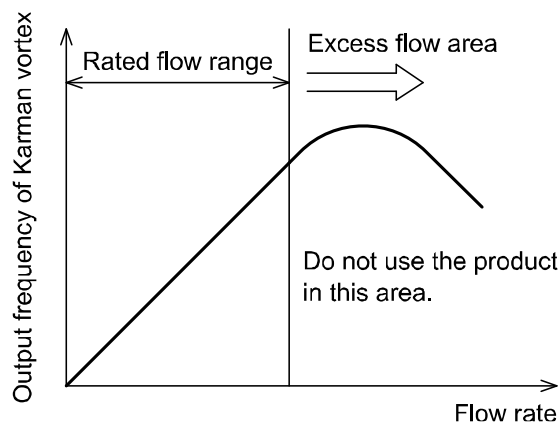

*Maintenance

- Perform regular maintenance and inspections.
There is a risk of unexpected malfunction of components due to the malfunction of equipment and machinery.
- Turn off the power supply, stop the fluid and check the safety before performing any maintenance.
There is a risk of unexpected malfunction.
- Do not use solvents such as benzene, thinner etc. to clean the product.
They could damage the surface of the body and erase the markings on the body.
Use a soft cloth to remove stains.
For heavy stains, use a cloth lightly dampened with diluted neutral detergent, then wipe up any residue with a dry cloth.

Model indication and How to Order

PF2W 5 - - -

Remote type sensor

Connector
(Refer to page 12.)

Rated flow range

Output specification

Symbol	Content
04	0.5 to 4 L/min
20	2 to 16 L/min
40	5 to 40 L/min
11 *	10 to 100 L/min

Symbol	Content	Applicable monitor model
Nil	Output for PF2W3##	PF2W3## Series
1	Output for PF2W3## + Analogue (1 to 5 V)	PF2W3## Series, PF2W2## Series (Used for analogue output only)
2	Output for PF2W3## + Analogue (4 to 20 mA)	PF2W3## Series

*: [11 (10 to 100 L/min)] cannot be selected when [T (0 to 90 °C)] is selected as the operating fluid temperature.

Fluid temperature specification

Lead wire
(Refer to page 12.)

Symbol	Content
Nil	0 to 50 °C
T *	0 to 90 °C

*: [T (0 to 90 °C)] cannot be selected when [11 (10 to 100 L/min)] is selected as the rated flow range.

Thread type

Port size

Symbol	Content
Nil	Rc
N	NPT
F	G

Symbol	Port size	Rated flow range			
		04	20	40	11
03	3/8 inch	●	●	-	-
04	1/2 inch	-	●	●	-
06	3/4 inch	-	-	●	●
10	1 inch	-	-	-	●

Lead wire

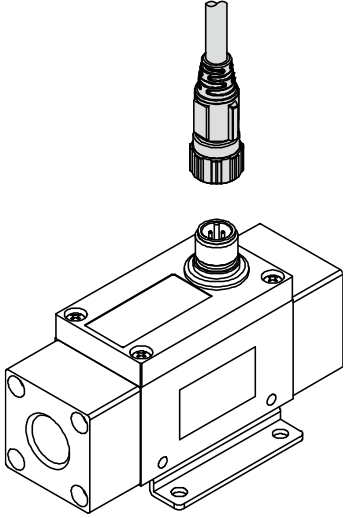
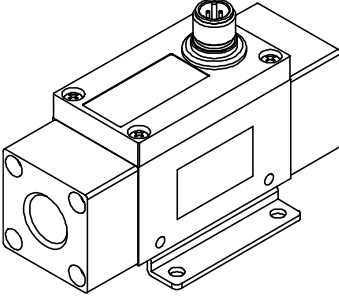
NIL	N
<p data-bbox="225 376 539 439">with lead wire and connector (Straight, 3 m)</p> 	<p data-bbox="746 376 927 405">without lead wire</p> 

*: Lead wire is not assembled with the product, but shipped together.

Connector

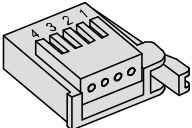
NIL	C
<p data-bbox="284 1173 480 1202">without connector</p>	<p data-bbox="683 1173 991 1202">with sensor connector (1 pc.)</p> 

*: Connector is not assembled with the lead wire, but shipped together.

Accessories/Part number

If an accessory is required separately, order using the following part numbers.

Part number	Description	Remarks
ZS-37-A	Lead wire and connector (Straight)	Length: 3 m
ZS-37-B	Lead wire and connector (Right angle)	Length: 3 m
ZS-29-T	Bracket (PF2W704/720)	Mounting screw (3 x 12 Self tapping screw) 4 pcs.
ZS-29-V	Bracket (PF2W740/7##T)	Mounting screw (3 x 12 Self tapping screw) 4 pcs.
ZS-29-W	Bracket (PF2W711)	Mounting screw (3 x 12 Self tapping screw) 4 pcs.
ZS-28-CA-4	Sensor connector	1 pc.

Summary of Product parts

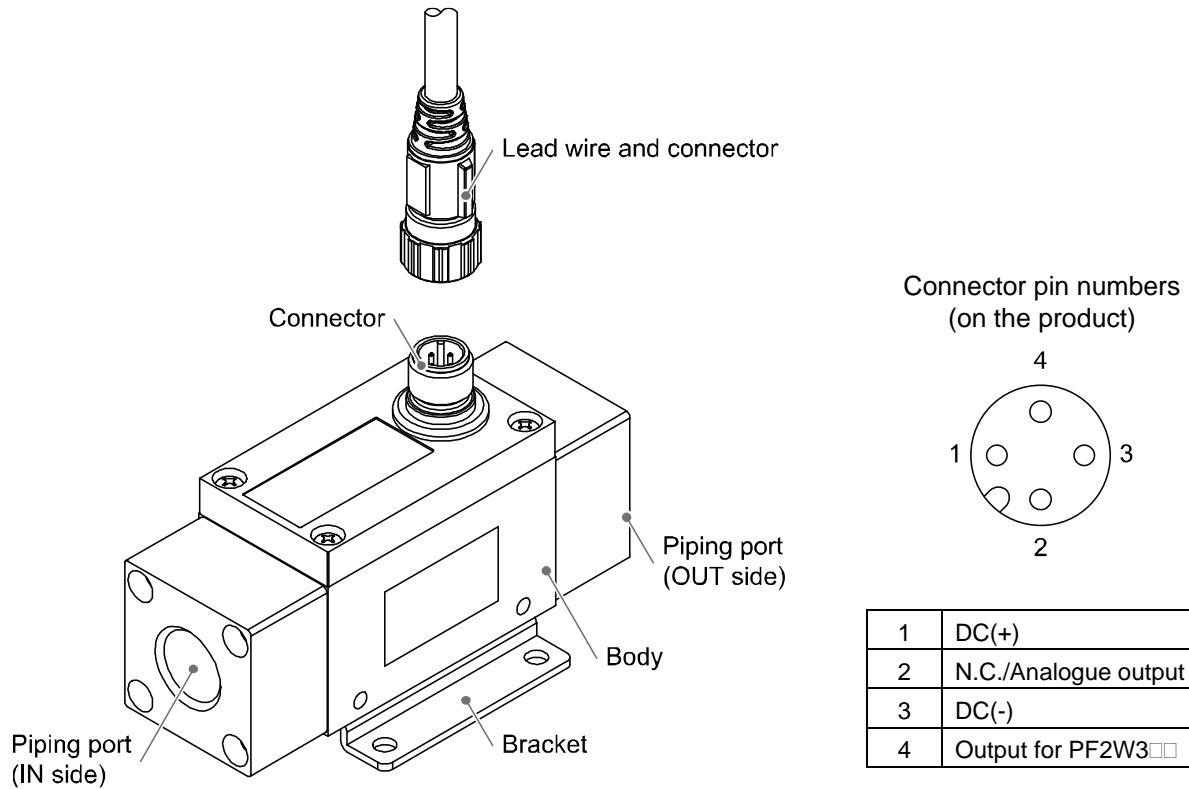

Item	Description
Lead wire and connector	Lead wire to supply power and transmit output signals.
Connector	Connector for electrical connections.
Piping port	Connected to the fluid inlet at IN and to the fluid outlet at OUT.
Bracket	Bracket for mounting the product.
Body	The body of the product.

■ Definition and terminology

	Terms	Meaning
A	Analogue output	A type of variable output that has a value proportional to the measured quantity. When the analogue output is in the range of 1 to 5 V or 4 to 20 mA, it will vary continuously, following the change of flow
	Attachment	A metal part on both sides of the product to connect piping.
C	Cavitation	A phenomenon that may occur in a fluid moving at high speed. In the parts of the fluid where the pressure is low, vapour bubbles form and then rapidly collapse. If cavitation is present for a prolonged period, exposed surfaces will be damaged; this is called cavitation damage or erosion.
F	Fluid temperature	Range of fluid temperature that can be measured by the product.
	F.S. (Full span, Full scale)	Stands for "full span" or "full scale", and indicates varied analogue output range at rated value. For example, when analogue output is 1 to 5 V, F.S. = 5[V] - 1[V] = 4[V], (ref. 1%F.S. = 4[V]x1% = 0.04[V]) The maximum measuring range or change in analogue output over the maximum measurement range.
K	Karman vortex	When an object is placed in a fluid stream, a vortex will be created in the fluid on the downstream side. This vortex is called a Karman vortex. The frequency at which the vortices are generated is proportional to the fluid velocity, therefore it is possible to calculate the fluid flow rate by measuring the Karman vortex frequency.
O	Operating humidity range	The ambient humidity range within which the product will meet all published specifications.
	Operating temperature range	The ambient temperature range within which the product will meet all published specifications.
P	Part in contact with fluid	A part that comes into physical contact with the fluid.
	Pressure characteristics	The amount of variation in the analogue output or display value when the supply pressure is changed.
	Proof pressure	The pressure beyond which the flow switch will be damaged.
R	Rated flow range	The flow range within which the product will meet all published specifications.
	Rated pressure range	The pressure range within which the product will meet all published specifications.
	Repeatability	Reproducibility of the display or analogue output value, when the flow is repeatedly changing.
	Response time	Time from when the target flow is applied until the flow reaches 90% of the set value.
T	Temperature characteristics	The amount of variation in the analogue output or display value when the ambient temperature is changed.
W	Water hammer	A momentary steep pressure increase due the spread of pressure by closing a contactor such as a valve for an extremely short time while there is a flow. This pressure increase is known as water hammer or impact pressure.

Mounting and Installation

■ Installation

- Never mount the product in a location that will be used as a foothold.

● Installing

- Install the product (with bracket) using the M4 screws (4 pcs.).
- Bracket thickness is approximately 1.6 mm (approximately 2.0 mm for PF2W511).
- Refer to the dimension drawing of the bracket (page 31) for mounting hole dimensions.

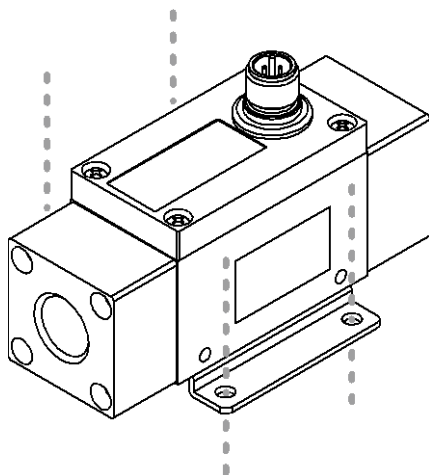

■ Piping

- Use the product within the specified operating pressure range and temperature range.
- Proof pressure is 1.5 MPa.
- Connect the piping to the fittings.
- Mount the product so that the fluid direction is the same as the arrow indicated on the product.
- The piping on the IN side must have a straight section of piping whose length is 8 times the piping diameter or more.
- Avoid sudden changes in the piping size on the IN side of the product.

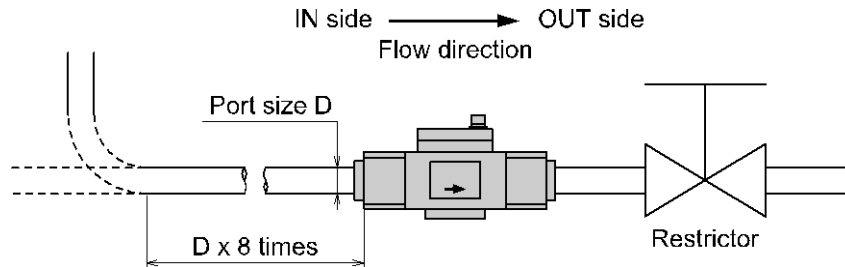

- Bubbles may be generated depending on the piping design. Refer to an example of recommended piping system.
(If the fluid detection part is always filled with liquid, there will be no problem.)

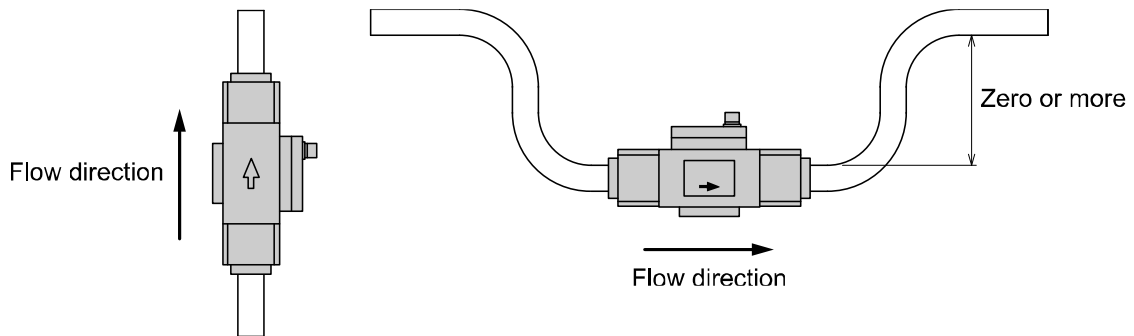

●Connecting the piping

- Ensure that the metal piping attachments are tightened to the required torque (refer to the table below).
- If the tightening torque is exceeded, the product can be broken. If the tightening torque is insufficient, the fittings may become loose.
- When connecting piping to the product, a spanner should be used on the metal piping attachment only. Using a spanner on other parts may damage the product.
- Avoid any sealing tape from entering inside the piping.
- Ensure that there is no leakage from loose piping.

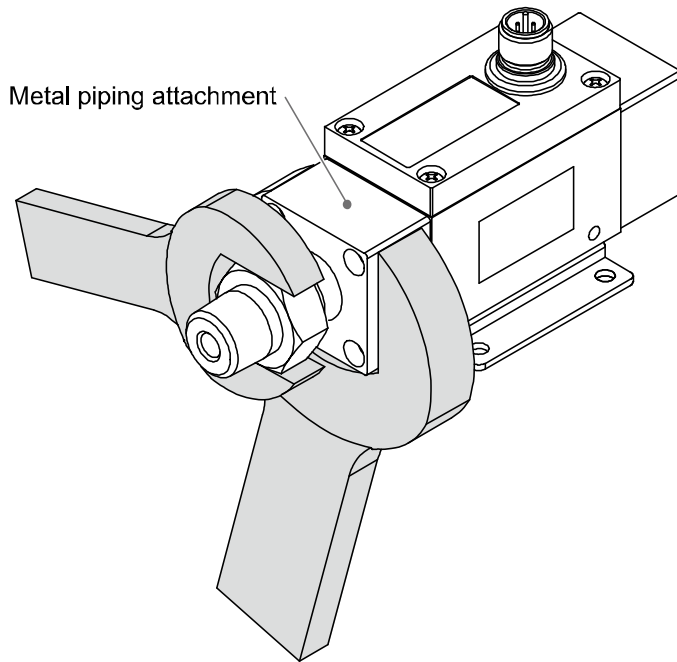

Nominal thread size	Required torque
Rc(NPT)3/8	15 to 20 N•m
Rc(NPT)1/2	20 to 25 N•m
Rc(NPT)3/4	28 to 30 N•m
Rc(NPT)1	36 to 38 N•m

Model	Width across flats of attachment
PF2W504	34 mm
PF2W520	
PF2W540	
PF2W511	45 mm
PF2W504T	34 mm
PF2W520T	
PF2W540T	

■Wiring

- Connections should only be made with the power supply turned off.
- Use separate routes for the product wiring and any power or high voltage wiring. Otherwise, malfunction may result due to noise.
- Ensure that the FG terminal is connected to ground when using a commercially available switch-mode power supply. When a switch-mode power supply is connected to the product, switching noise will be superimposed and the product specification can no longer be met. This can be prevented by inserting a noise filter, such as a line noise filter and ferrite core, between the switch-mode power supply and the product, or by using a series power supply instead of a switch-mode power supply.

●Connector Pin numbers

When the lead wire and connector designated for the PF2W5 is used, the wire colours will apply as shown in the diagram.

Connector Pin numbers (on the lead wire)

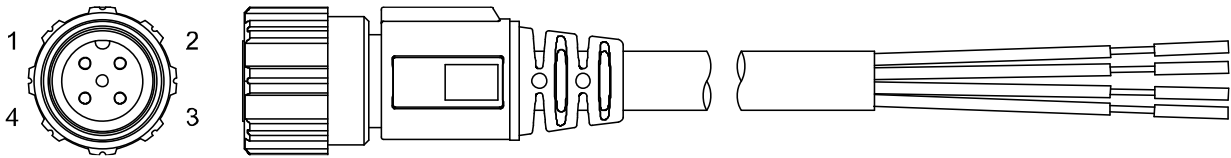

Pin number	Content	Colour
1	DC(+)	Brown
2	N.C./Analogue output	White
3	DC(-)	Blue
4	Output for PF2W3##	Black

●Connecting the wiring

How to connect the body and the lead wire and connector

- Align the lead wire connector with the connector key groove, and insert vertically.
- Connection is complete when the knurled part is fully tightened. Check that the connection is not loose.

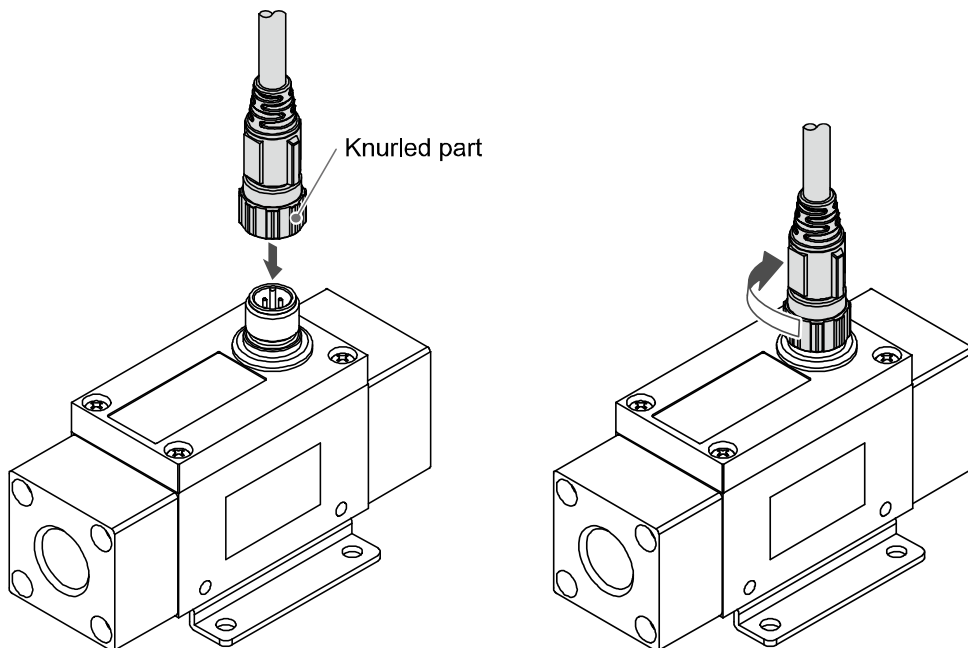

Attaching the sensor connector to the lead wire (When the product connects to the PF2W2##)

Refer to the PF2W2## operation manual for details of the sensor connector pin numbers.

- Strip the lead wire as shown. Do not cut the insulator.

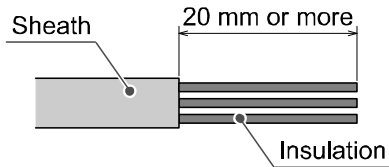

- Insert the corresponding wire colour into the pin number printed on the sensor connector, to the bottom, then part A shown should be pressed in by hand to make temporary connection.

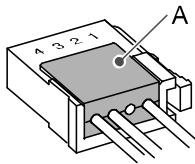

- Part A should then be pressed in using a suitable tool, such as pliers.

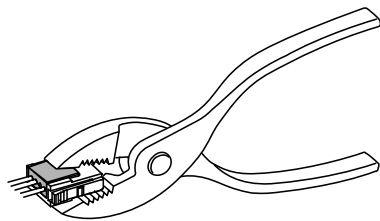

*: The connector cannot be re-used once it has been fully crimped.

In cases of connection failure such as incorrect order of wires or incomplete insertion, please use the new connector.

● Internal circuit and wiring example

When the lead wire and connector designated for the PF2W5 is used, the wire colours will apply as shown in the diagram.

Output for PF2W3## type

PF2W5##-####-#

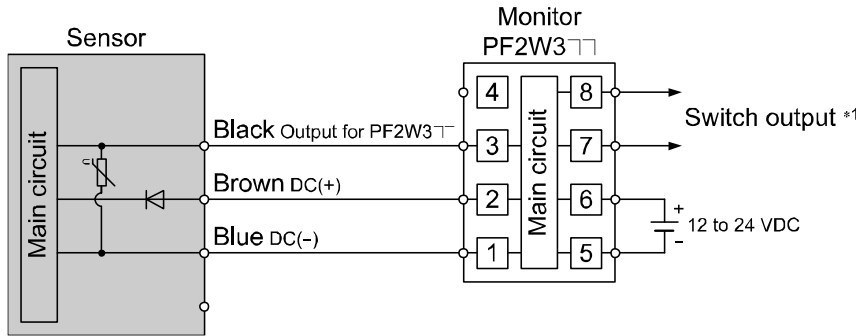

Output impedance: 1 kΩ

*1: Refer to the PF2W3## operation manual for details of the flow monitor.

Output for PF2W3## + Analogue (1 to 5 V) type

PF2W5##-####-1-#

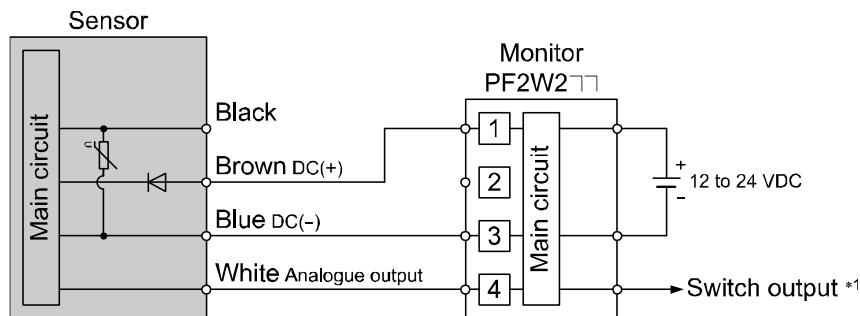
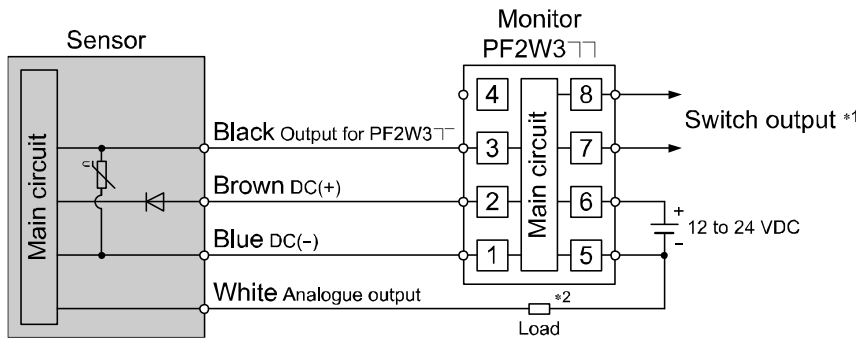

Analogue output: 1 to 5 V

Output impedance: 1 kΩ

*1: Refer to the PF2W3## or PF2W2## operation manual for details of the flow monitors.

*2: Load indicates analogue input equipment such as a voltmeter.

Output for PF2W3## + Analogue (4 to 20 mA) type

PF2W5##-#####-2-#

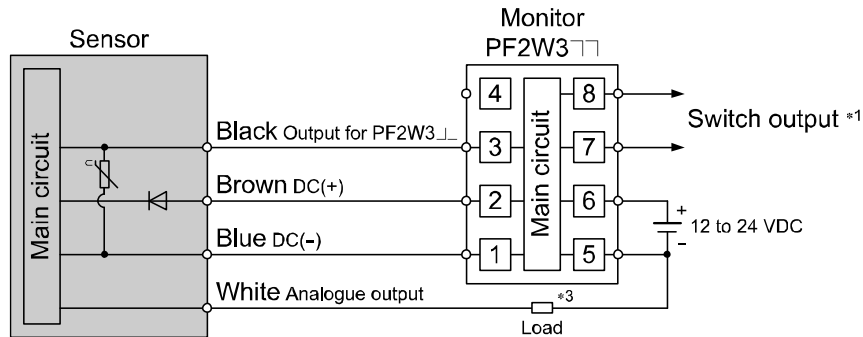

Analogue output: 4 to 20 mA

Load impedance: 300 Ω (12 VDC)
600 Ω (24 VDC)

*1: Refer to the PF2W3## operation manual for details of the flow monitor.

*3: Load indicates analogue input equipment such as an ammeter.

Troubleshooting

Troubleshooting

If an operation failure occurs with the product, use the chart below to find out the cause of the problem. If none of the countermeasures seem to be applicable, or a replacement product operates normally when installed, the product may be faulty. A product can be damaged by the operating environment (system configuration etc). If the product seems to be faulty, please contact SMC.

■ Cross-reference for troubleshooting

Fault		Probable cause	Recommended action
Output	There is no output.	Wiring failure.	Correct the wiring.
		Connector loose.	Check the connector.
	Output is unstable.	Foreign matter inside.	Set up filter (approx.40 mesh) at IN side of product. If there is foreign matter stuck to the mesh, remove it completely, taking care not to damage the product.
		Piping is connected in the wrong direction.	Install with the mounting direction corresponding to the flow direction (arrow indicated on the product).
		Insufficient fluid supply.	Full up the fluid path.
		Pulsation in the flow.	Change to a pump that has less pulsation. Install a tank to reduce the pressure fluctuation. Change the piping to elastic piping such as rubber tube.
		Liquid leakage.	Check that seal tape has been applied correctly. Reconnect the pipes with the specified tightening torque.

Specification

Specifications

Model		PF2W504(T)	PF2W520(T)	PF2W540(T)	PF2W511
Applicable fluid		water and ethylene glycol solution 50% (viscosity of 3 mPa·s (3cP) or less) *1			
Fluid temperature		Without T: 0 to 50 °C (no condensation or freezing) With T: 0 to 90 °C (no condensation or freezing)			0 to 50 °C (no condensation or freezing)
Flow	Rated flow range	0.5 to 4.0 L/min	2 to 16 L/min	5 to 40 L/min	10 to 100 L/min
Pressure	Rated pressure range	0 to 1 MPa			
	Proof pressure	1.5 MPa			
Output for PF2W3□□	Max. applied voltage	30 VDC			
Analogue output	Voltage output	1 to 5 V			
	Output impedance	1 kΩ			
	Current output	4 to 20 mA			
	Load impedance	Power supply voltage 12 V: 300 Ω Power supply voltage 24 V: 600 Ω			
	Accuracy *2	±5%F.S. max.			
	Repeatability *2	±1%F.S. max. (connected to PF2W3##), ±3%F.S. max. (connected to PF2W2##)			
	Response time	1 s or less			
Supply voltage		12 to 24 VDC ±10%			
Power consumption (no load)		20 mA or less			
Environment	Enclosure	IP65			
	Operating temperature range	Operation: 0 to 50 °C, Storage: -25 to 85 °C (no condensation or freezing)			
	Operating humidity range	Operation, Storage: 35 to 85%R.H. (no condensation)			
	Temperature characteristics	±5%F.S. max. (0 to 90 °C, 25 °C reference)			
	Withstand voltage	1000 VAC, for 1 minute between the external terminals and case			
	Insulation resistance	50 MΩ or more (at 500 VDC) between external terminals and case			
Standards and regulations		CE/UKCA marked			
Port size (Rc, NPT, G)		3/8	3/8, 1/2	1/2, 3/4	3/4, 1
Materials of parts in contact with fluid		SUS, NBR *3, PPS			
Weight	Product	410 g *4	470 g *4	650 g *4	1100 g
	Lead wire and connector	100 g			

*1: An ethylene glycol aqueous solution is applicable for T type only. Refer to the measurable range chart for ethylene glycol aqueous solution (page 25).

*2: Total accuracy when used with applicable flow monitor.

*3: The material is FKM for product with operating fluid temperature specification [0 to 90 °C].

*4: The weight is 660 g for product with operating fluid temperature specification [0 to 90 °C].

*: •The form of the G thread (including the major and minor diameter and pitch of the internal thread) is based on JIS B0202 (ISO228-1).

•Products indicated as ISO1179-1 (G thread for hydraulics) or ISO16030 (G thread for pneumatics) are based on JIS B0202 (ISO228-1) for effective depth of thread, seat surface area, surface roughness and squareness.

•For ISO1179-1 (G thread for hydraulics), the withstand pressure is specified for each product. SMC do not guarantee the withstand pressure specified in ISO1179-1, ISO1179-2, ISO1179-3, or ISO1179-4.

•For ISO16030 (G thread for pneumatics), the withstand pressure is specified for each product. SMC do not guarantee the withstand pressure specified in ISO16030.

Lead wire Specifications

Sheath	Finished outside diameter	approx. 4 mm
	Material	Oil-resistant PVC
Insulator	Colours	Brown, White, Black, Blue
	Outside diameter	approx. 1.14 mm
Conductor	Nominal cross section area	AWG23
	Outside diameter	approx. 0.72 mm

■ Characteristics data

● Flow characteristics (pressure loss)

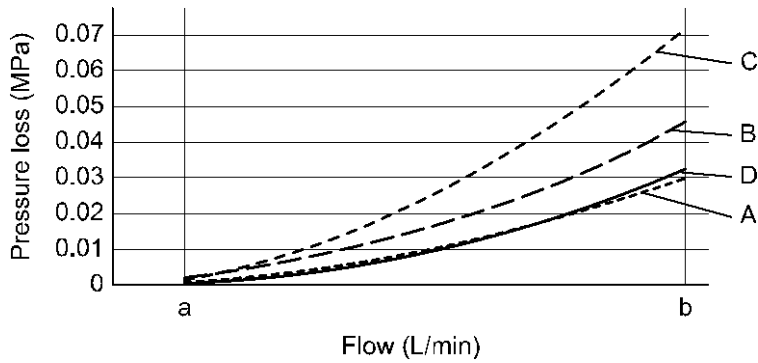

Model	Graph	a(L/min)	b(L/min)
PF2W504(T)	A	0.5	4
PF2W520(T)	B	2	16
PF2W540(T)	C	5	40
PF2W511	D	10	100

● Analogue output

	A	B	C
Voltage output	1 V	1.5 V (1.4V)	5 V
Current output	4 mA	6 mA (5.6 mA)	20 mA

The value in () is when PF2W511 is used.

Model	Rated flow range [L/min]	
	Min.	Max.
PF2W504(T)	0.5	4
PF2W520(T)	2	16
PF2W540(T)	5	40
PF2W511	10	100

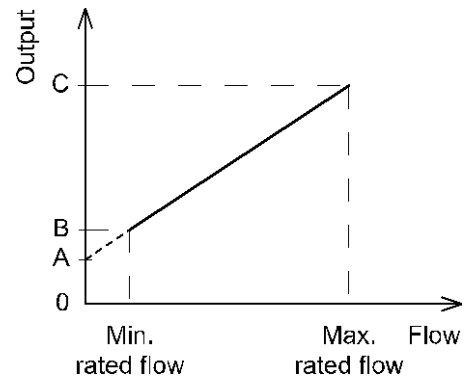

● Measurable range of ethylene glycol aqueous solution (Reference value)

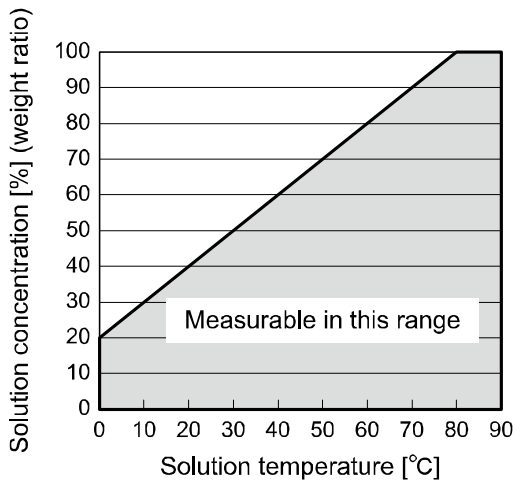

*: The product with operating fluid temperature specification [0 to 50 °C] is not suitable for fluids with a temperature greater than 50 °C.

■Dimensions (in mm)

PF2W504/520

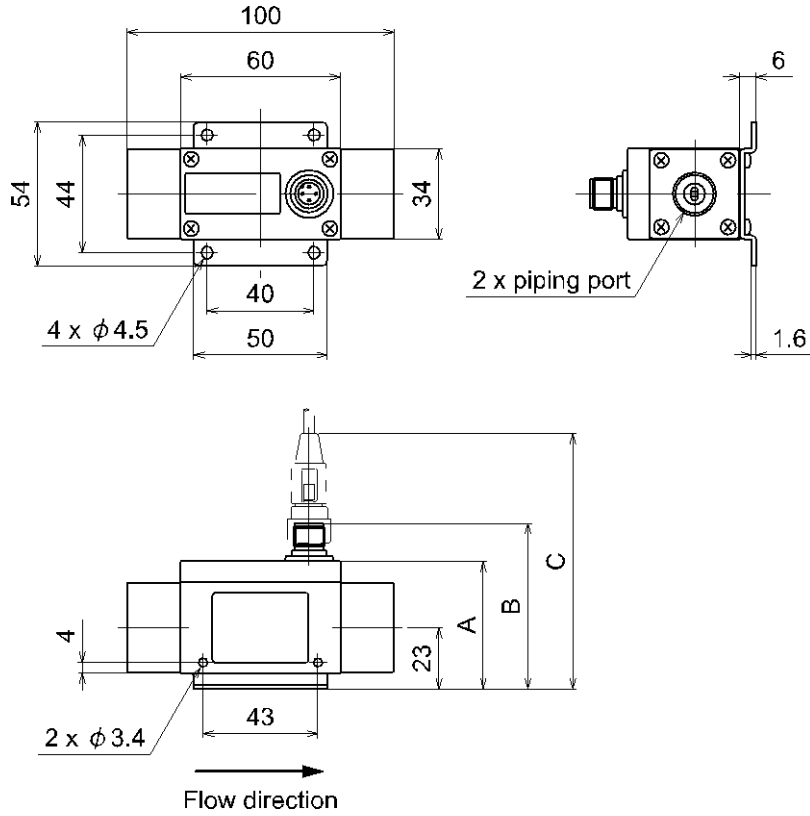

Output specifications	A	B	C
Output for PF2W3##	48 mm	62 mm	94.3 mm
Output for PF2W3## + Analogue output	58 mm	72 mm	104.3 mm

PF2W540

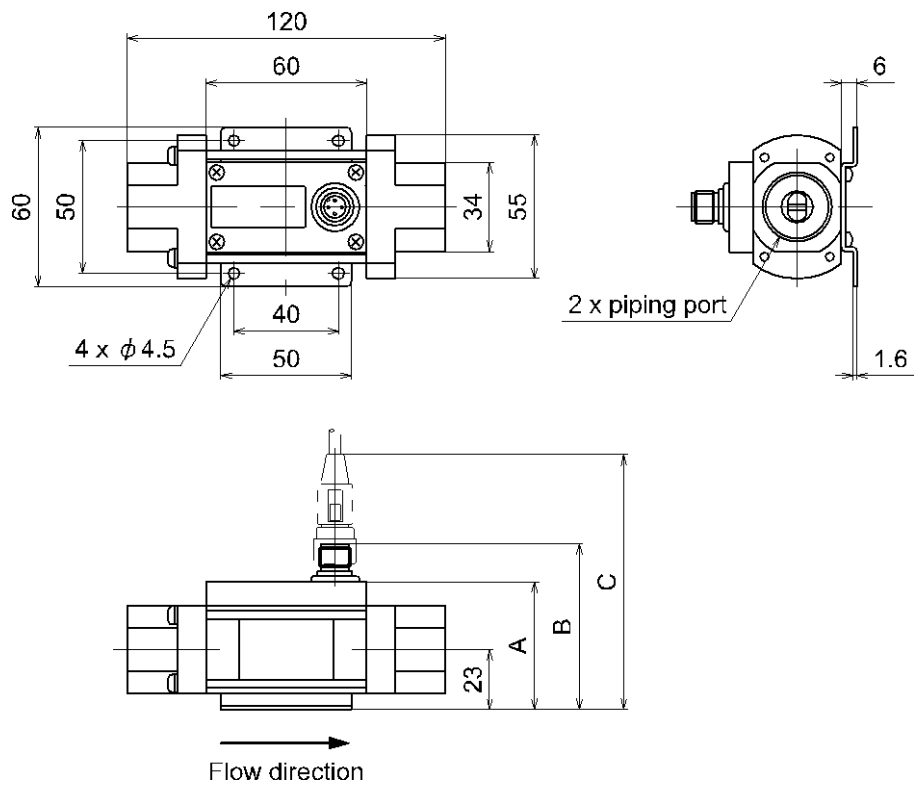

Output specifications	A	B	C
Output for PF2W3##	48 mm	62 mm	94.3 mm
Output for PF2W3## + Analogue output	58 mm	72 mm	104.3 mm

PF2W511

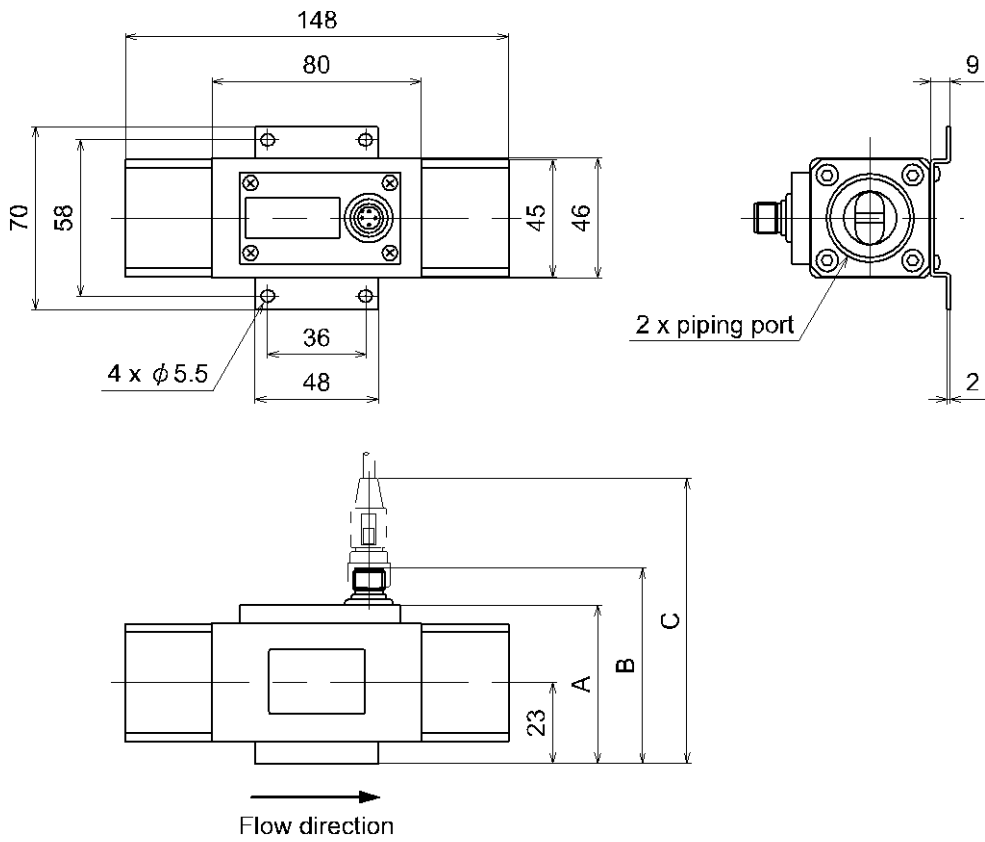

Output specifications	A	B	C
Output for PF2W3##	63 mm	77 mm	118.3 mm
Output for PF2W3## + Analogue output	73 mm	87 mm	128.3 mm

PF2W504T/520T/540T

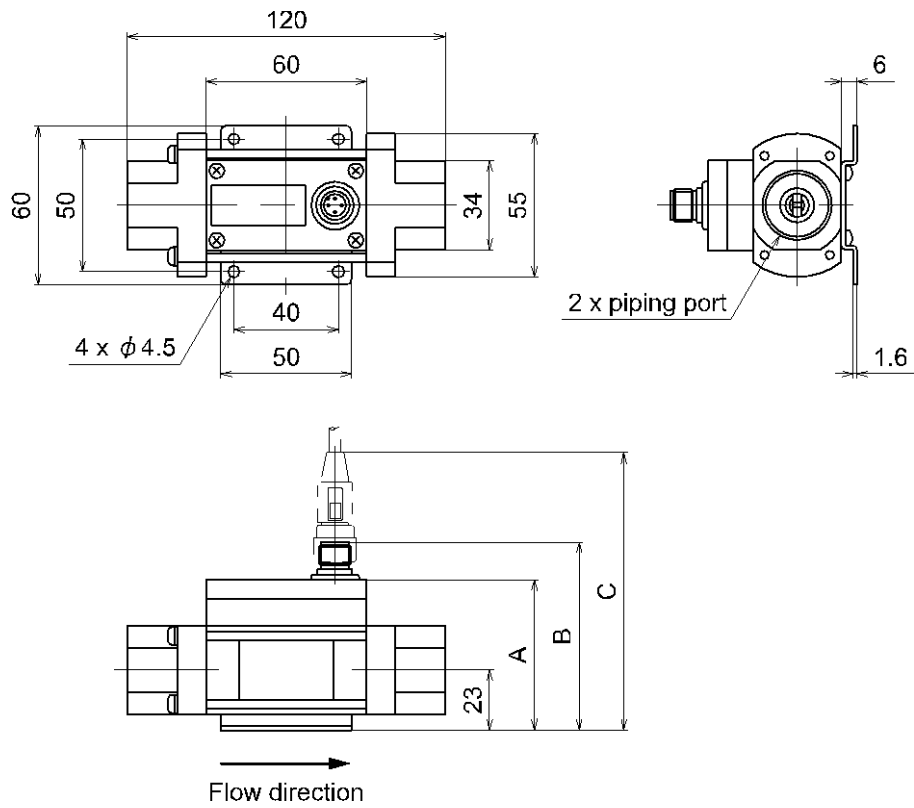

Output specifications	A	B	C
Output for PF2W3##	58 mm	62 mm	104.3 mm
Output for PF2W3## + Analogue output	68 mm	72 mm	114.3 mm

Lead wire and connector (Straight): ZS-37-A

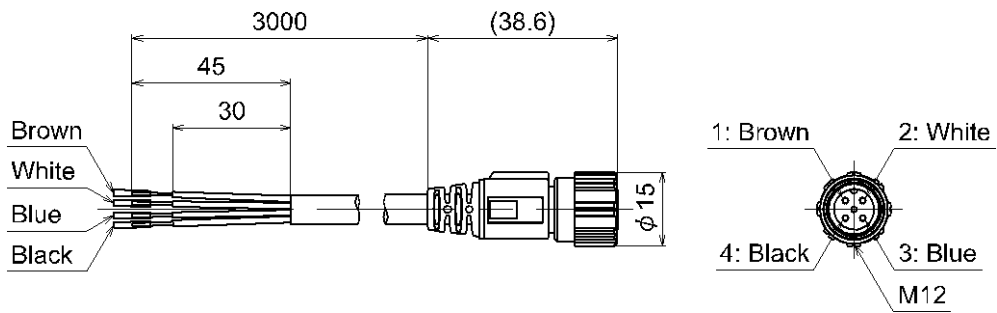

Lead wire and connector (Angle): ZS-37-B

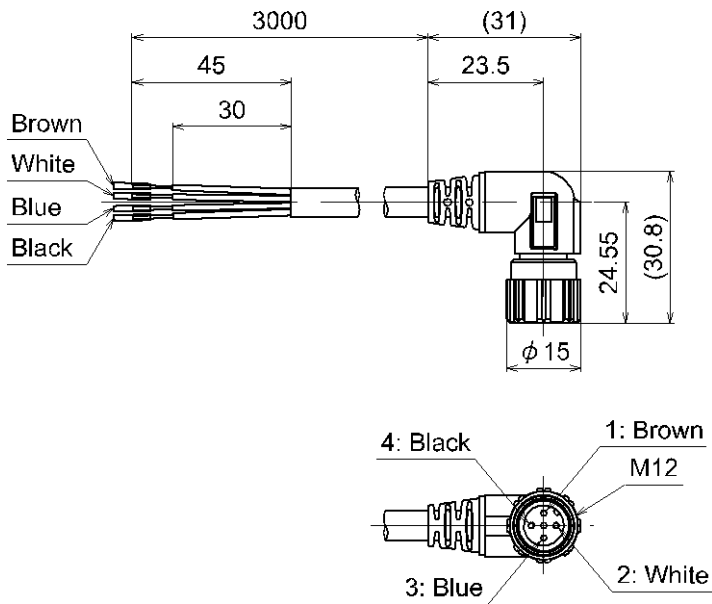

Bracket (PF2W504/520): ZS-29-T

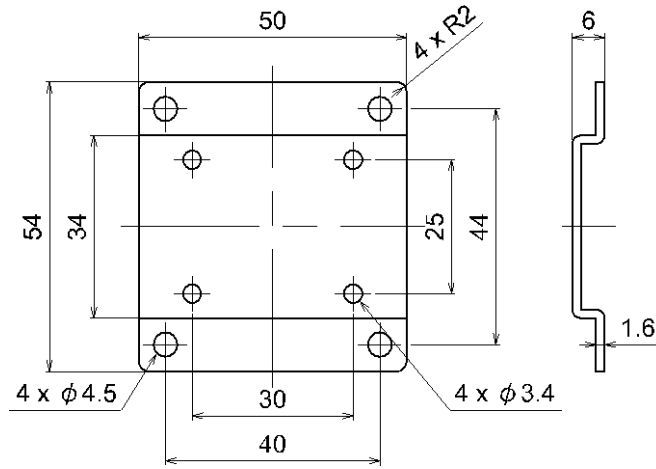

Bracket (PF2W540/5□□T): ZS-29-V

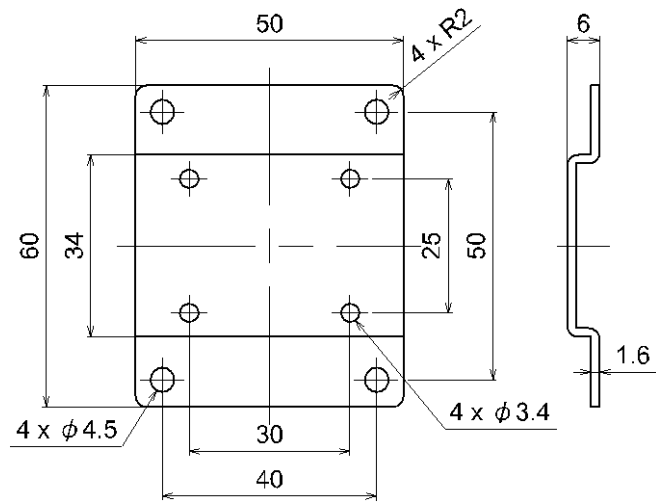

Bracket (PF2W511): ZS-29-W

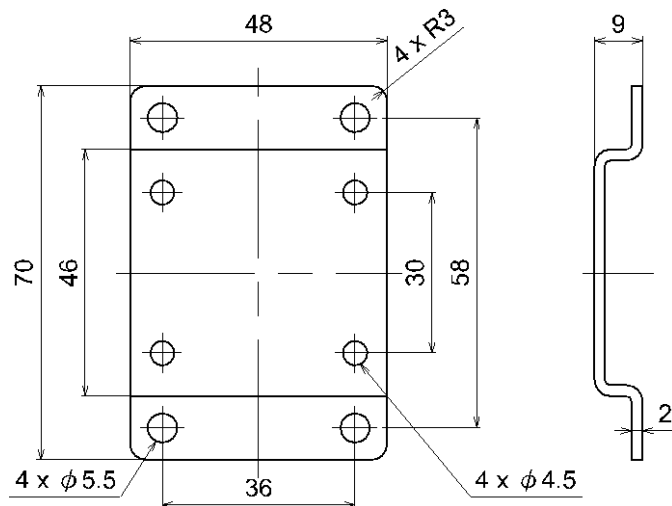

Revision history

A: Contents revised in several places.
B: Revision. (kPa → MPa (page 25))
C: Contents revised in several places.
D: Contents revised in several places. [July 2018]
E: Contents revised in several places.
[June 2024]

SMC Corporation

Tel: + 81 3 5207 8249 Fax: +81 3 5298 5362
URL <https://www.smcworld.com>

Note: Specifications are subject to change without prior notice and any obligation on the part of the manufacturer.
© SMC Corporation All Rights Reserved

