



Operation Manual

PRODUCT NAME

Process Pump

MODEL / Series / Product Number

PB1011A

PB1013A

SMC Corporation

Contents

Safety Instructions	2
Model Indication and How to Order	4
Names and Functions of Product Parts	5
Piping and Operation	6
Working Principle	7
Precautions	8
1. Caution on Design	8
2. Mounting	9
3. Piping	9
4. Air supply	10
5. Operating Environment	10
6. Maintenance	11
7. Lubrication	12
8. Caution on Handling	13
9. Return of Product	13
Applicable Fluids	14
Specifications	15
Performance Curve	16
Flow Rate Characteristics	16
Air Consumption	17
Viscosity Characteristics	18
Maintenance Parts	19
Dimensions	20
Troubleshooting	21



Safety Instructions

These safety instructions are intended to prevent hazardous situations and/or equipment damage. These instructions indicate the level of potential hazard with the labels of “**Caution**,” “**Warning**” or “**Danger**.” They are all important notes for safety and must be followed in addition to International Standards (ISO/IEC)*¹⁾, and other safety regulations.

*1) ISO 4414: Pneumatic fluid power - General rules and safety requirements for systems and their components
ISO 4413: Hydraulic fluid power - General rules and safety requirements for systems and their components
IEC 60204-1: Safety of machinery - Electrical equipment of machines - Part 1: General requirements
ISO 10218-1: Robots and robotic devices - Safety requirements for industrial robots - Part 1: Robots
etc.



Danger

Danger indicates a hazard with a high level of risk which, if not avoided, will result in death or serious injury.



Warning

Warning indicates a hazard with a medium level of risk which, if not avoided, could result in death or serious injury.



Caution

Caution indicates a hazard with a low level of risk which, if not avoided, could result in minor or moderate injury.

Warning

1. The compatibility of the product is the responsibility of the person who designs the equipment or decides its specifications.

Since the product specified here is used under various operating conditions, its compatibility with specific equipment must be decided by the person who designs the equipment or decides its specifications based on necessary analysis and test results. The expected performance and safety assurance of the equipment will be the responsibility of the person who has determined its compatibility with the product. This person should also continuously review all specifications of the product referring to its latest catalog information, with a view to giving due consideration to any possibility of equipment failure when configuring the equipment.

2. Only personnel with appropriate training should operate machinery and equipment.

The product specified here may become unsafe if handled incorrectly. The assembly, operation and maintenance of machines or equipment including our products must be performed by an operator who is appropriately trained and experienced.

3. Do not service or attempt to remove product and machinery/equipment until safety is confirmed.

1. The inspection and maintenance of machinery/equipment should only be performed after measures to prevent falling or runaway of the driven objects have been confirmed.
2. When the product is to be removed, confirm that the safety measures as mentioned above are implemented and the power from any appropriate source is cut, and read and understand the specific product precautions of all relevant products carefully.
3. Before machinery/equipment is restarted, take measures to prevent unexpected operation and malfunction.

4. Our products cannot be used beyond their specifications. Our products are not developed, designed, and manufactured to be used under the following conditions or environments. Use under such conditions or environments is not covered.

1. Conditions and environments outside of the given specifications, or use outdoors or in a place exposed to direct sunlight.
2. Use for nuclear power, railways, aviation, space equipment, ships, vehicles, military application, equipment affecting human life, body, and property, fuel equipment, entertainment equipment, emergency shut-off circuits, press clutches, brake circuits, safety equipment, etc., and use for applications that do not conform to standard specifications such as catalogs and operation manuals.
3. Use for interlock circuits, except for use with double interlock such as installing a mechanical protection function in case of failure. Please periodically inspect the product to confirm that the product is operating properly.



Safety Instructions

Caution

We develop, design, and manufacture our products to be used for automatic control equipment, and provide them for peaceful use in manufacturing industries.

Use in non-manufacturing industries is not covered.

Products we manufacture and sell cannot be used for the purpose of transactions or certification specified in the Measurement Act.

The new Measurement Act prohibits use of any unit other than SI units in Japan.

Limited warranty and Disclaimer/Compliance Requirements

The product used is subject to the following “Limited warranty and Disclaimer” and “Compliance Requirements”.

Read and accept them before using the product.

Limited warranty and Disclaimer

1. The warranty period of the product is 1 year in service or 1.5 years after the product is delivered, whichever is first.*2)

Also, the product may have specified durability, running distance or replacement parts. Please consult your nearest sales branch.

2. For any failure or damage reported within the warranty period which is clearly our responsibility, a replacement product or necessary parts will be provided.

This limited warranty applies only to our product independently, and not to any other damage incurred due to the failure of the product.

3. Prior to using SMC products, please read and understand the warranty terms and disclaimers noted in the specified catalog for the particular products.

***2) Vacuum pads are excluded from this 1 year warranty.**

A vacuum pad is a consumable part, so it is warranted for a year after it is delivered.

Also, even within the warranty period, the wear of a product due to the use of the vacuum pad or failure due to

the deterioration of rubber material are not covered by the limited warranty

Compliance Requirements

1. The use of SMC products with production equipment for the manufacture of weapons of mass destruction (WMD) or any other weapon is strictly prohibited.

2. The exports of SMC products or technology from one country to another are governed by the relevant security laws and regulations of the countries involved in the transaction. Prior to the shipment of a SMC product to another country, assure that all local rules governing that export are known and followed.

Model Indication and How to Order

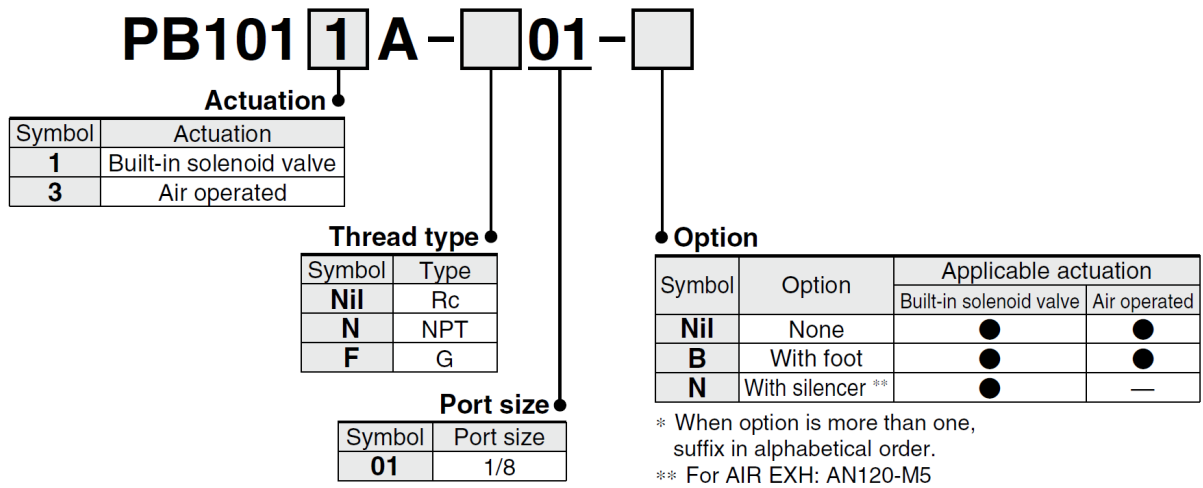

Names and Functions of Product Parts

PB1011A

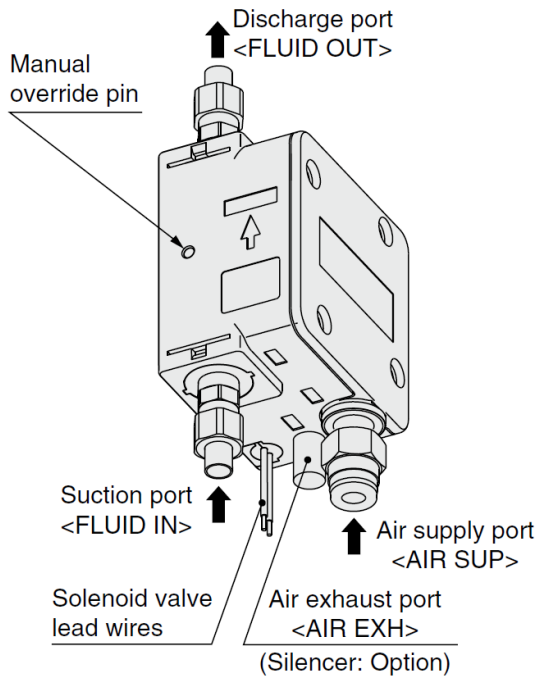

PB1013A

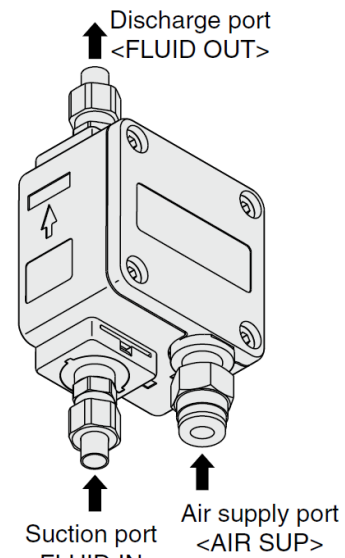

Description	Functions
Suction port (FLUID IN)	Sucks the fluid to be transferred. Connect suction piping.
Discharge port (FLUID OUT)	Discharges the fluid taken in the pump. Connect discharge piping.
Air supply port (AIR SUP)	Supplies air of set pressure. Connect the air piping.
Air exhaust port (AIR EXH)	Exhausts pilot air. (Only for PB1011A)
Manual	The pump operates one time per push. (Only for PB1011A)
Lead wires	Lead wires of solenoid valve.

Piping and Operation

⚠ Caution

Be sure that the discharge port <FLUID OUT> is on top when the pump is mounted. Supply clean air that has passed through a filter or mist separator, etc., to the air supply port <AIR SUP>. Air that contains debris or drainage, etc., will have an adverse effect on the built-in solenoid valve, and will cause malfunction of the pump.

Maintain the proper tightening torque for fittings or mounting bolts. Looseness can cause problems such as liquid or air leakage, while over-tightening can cause damage to threads or parts, etc.

Operation

1. Connect air piping to the air supply port <AIR SUP>, and connect piping for transferred fluid to the suction port <FLUID IN> and the discharge port <FLUID OUT>.

2. Connect the solenoid valve lead wires to a 24 VDC power supply. Red is (+) and Black is (-).
(The PB1013A air-operated type must be equipped with a separate 3-port solenoid valve.)

3. Using a regulator, set the pilot air pressure within the range of 0.2 to 0.7 MPa.

By continuously turning the 24 VDC power ON/OFF, the fluid flows from the suction port <FLUID IN> to the discharge port <FLUID OUT>. The pump performs suction with its own power even without priming. Idle run of the pump shall be 3 minutes or less for the intake of the liquid.

4. To stop the pump turn OFF the 24 VDC power. Also, be sure to turn OFF the power when the discharge side is closed. If the pump is stopped for a long time, exhaust the air from the <AIR SUP> port. The manual override pin is used for manual operation when there is no electric power. Each time it is pressed, there is one reciprocal operation.

For the PB1013A air-operated type, stop the 3-port solenoid valve, and be sure to discharge air from the pump. Although the pump can be stopped by closing the throttle installed in the discharge side, avoid stopping operation for a long time. If the valve opens/closes suddenly, surge is generated, shortening the pump life. When the tank for fluid suction side is empty, stop operating the pump immediately.

Circuit example/Built-in solenoid valve

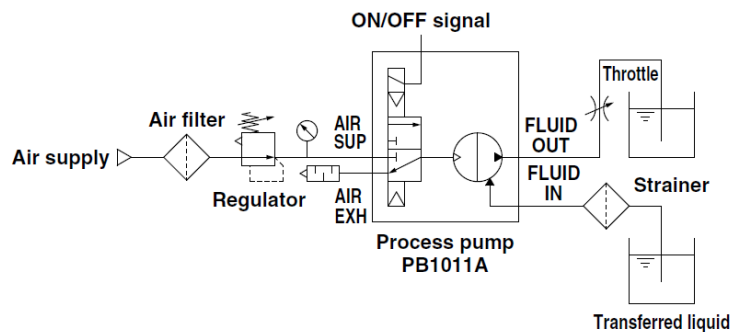

Circuit example/Air operated

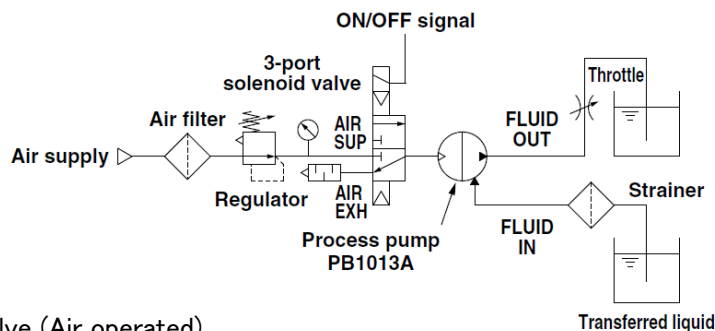

Recommended Valve (Air operated)

PB1013A	SYJ5□4
---------	--------

Working Principle

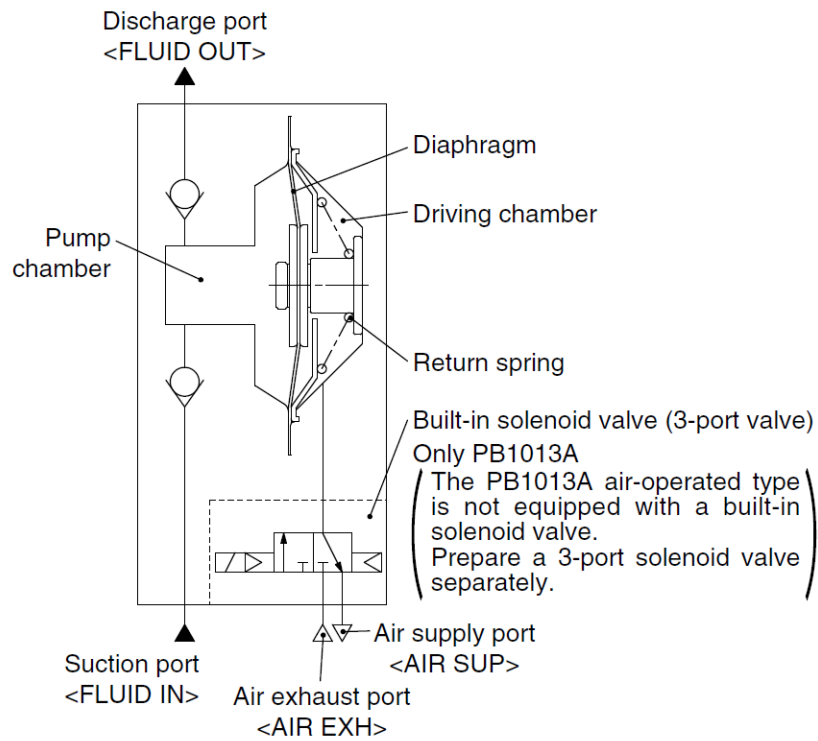

When air is supplied with the built-in solenoid valve turned ON (energized), air enters the driving chamber and the diaphragm moves to the left. Due to this movement, the fluid in the pump chamber passes through the upper check valve and is discharged to the discharge port <FLUID OUT>.

When the solenoid valve is turned OFF (de-energized), the air inside the driving chamber is evacuated to air exhaust port <AIR EXH>, and the diaphragm is moved to the right by the return force of the return spring. Due to this movement, the fluid on the suction port <FLUID IN> passes through the check valve and is sucked into the pump chamber.

The PB1011A transfers the fluid continuously by suction and discharge in turn by repeating ON/OFF of the built-in solenoid valve. The PB1013A air-operated type is operated by the ON/OFF operation of an external solenoid valve.

Precautions

1. Caution on Design

Warning

1. Confirm the specifications.

- Give careful consideration to operating conditions such as the application, fluid and environment, and use the product within the operating ranges specified in this catalog.
- The product is provided for physical, chemical and industrial equipment.

2. Fluids

- When ignitable fluid is used, select a product with metal wetted parts (aluminum, stainless steel). Always take countermeasures against static electricity.
- For the compatibility between the materials composing the product and the fluids, check the compatibility check list. Since the compatibility of the fluid used may vary depending on its type, additives, concentration, temperature, etc., give sufficient consideration when selecting the material.
- Use within the range of the operating fluid temperatures.
- If foreign matter is mixed in the fluid, these may cause abrasion of the inside of the pump resulting in a problem. Use an appropriate filter (strainer) to remove them. In general, 80 to 100 mesh (150 to 180 μ m) filters are recommended.
- When transferring a coagulable liquid, take measures to prevent it from coagulating in the pump.
- Flammable fluid cannot be used with the process pump with built-in solenoid valve (PB1011A). Do not use in an environment where flammable fumes are present or where flammable liquid may get stuck to the product.
- Take countermeasures to prevent the operating fluid from getting onto the body of the process pump.

3. Water hammer

If a valve is operated abruptly etc., a high pressure may be applied due to water hammer. Take measures to prevent pressures higher than specified from being applied.

<Examples of measures>

- Use a water hammer resistant valve to reduce the valve closing speed.
- Use an elastic piping material such as rubber hose or an accumulator to absorb the impact pressure.

4. Liquid seals

To ensure that fluid does not become sealed inside the process pump, when stopping the pump, relieve the discharge pressure inside it. As shown in the figure at right, make a circuit which has a relief valve installed on the system.

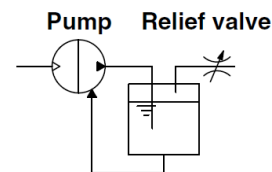

Countermeasures against liquid-sealed circuit

5. Fluid pressure supplied to the process pump

Feeding the fluid from the suction side into the pump under pressure, or drawing it using a negative pressure, will reduce the life of the pump.

6. Ensure space for maintenance.

Secure the space required for maintenance and inspection. Take into consideration also leakage from the product. When transferring a flammable liquid or a liquid that may affect the human body or environment, take measures including fire ban and keeping the area off limits.

7. When the diaphragm is broken, supply air will be mixed with the fluid or fluid will enter the air switching valve. When the supply air or debris contained in it affect the product performance, or the supply air is not suitable for the chemical resistance of the components, countermeasures need to be taken by the customer.

8. Use a design which prevents reverse pressure and reverse flow.

If reverse pressure or reverse flow occurs on the discharge side of the process pump, the equipment is liable to become damaged or malfunction. Take safety measures in designing the circuit.

9. Measures against static electricity

Take measures against static electricity as static electricity may occur depending on the fluid. Particularly, when circulating flammable fluid through the pump, be sure to take measures to prevent the occurrence of static electricity.

10. The pump cannot transfer gas. Do not allow it to idle for a long time.

If the pump is operated for a long time without any fluid inside or in a gas–fluid mixed state, the diaphragm may be damaged or the life may be shortened. Dry operation is only allowed during self–priming.

11. Condensation and freezing of the pilot port

The air supply port of the air operated type can cool down quickly due to expansion of the supply air, and this may cause condensation on the piping and the condensation may freeze during operation in winter. Take measures to ensure that water droplets from condensation are not splashed onto any electric parts or equipment.

12. PB1011A (Built–in solenoid valve)

Refer to “Handling Precautions for SMC Products” (M–E03–3) for the usage of the solenoid valve.

Caution

1. Suspension of the pump operation

- For the built–in solenoid valve type, cut off the 24 VDC voltage supplied to the process pump. If the process pump is stopped without cutting off the 24 VDC, a load will be applied to the internal parts, reducing the life of the pump.
- For the air operated type, stop the 3–port solenoid valve and exhaust the air inside the process pump. If the process pump is stopped while air is still being supplied to it, a load will be applied to the internal parts, reducing the life of the pump.

2. Reverse flow

The check valve inside the process pump does not completely stop reverse flow (the flow from the discharge side to the suction side). For this reason, fluid may sometimes flow from the discharge side to the suction side when the pump is stationary, etc). As a countermeasure, install a 2–way valve or a check valve. However, please note that when a check valve is installed, if the cracking pressure is high, defective suction may occur. (As a guide, the cracking pressure should be 0.02 MPa or less.)

2. Mounting

Caution

1. Read the operation manual before mounting the product.

Read the operation manual carefully and understand the contents before mounting the product. The manual should also be kept where it can be referred to whenever necessary.

2. Confirm the mounting orientation of the product.

Mount the product vertically so that the FLUID OUT port faces upward.

Also, secure all specified mounting positions when using the product.

If the propagation of the vibration of the pump is not acceptable, insert vibro–isolating rubber when mounting.

3. Piping

Caution

1. Flush the piping.

Flush and clean the piping before connecting the product. Any dirt or scale and the like left in the piping may cause malfunction or failure.

2. Use fittings with resin threads when connecting piping to the product with resin threads at the ports.

Using fittings with metal threads may cause damage to the ports.

3. Tighten screws with proper tightening torque.

When screwing fittings into the product, tighten them with proper tightening torque as shown below.

If loose, liquid or air leakage may occur. If overtightened, the threaded parts may be damaged.

Connection thread	Proper tightening torque [N·m]	Port names
Rc, NPT, G 1/8”	0.8 to 1	AIR SUP, FLUID IN, FLUID OUT
M5	1/8 turn after manual tightening	AIR EXH (Only PB1011A)

4. Air supply

Warning

1. Use clean air.

Do not use compressed air that includes chemicals, synthetic oils containing organic solvents, salinities or corrosive gases, etc., as it can cause damage or malfunction.

2. Pay attention to avoid freezing when operating the product in low temperatures.

The equipment operates while expanding the compressed air. During this time, the temperature inside the product decreases due to adiabatic expansion. If the ambient temperature is low, using compressed air containing a lot of moisture may cause freezing because heat cannot be gained from the surroundings. In this case, take freeze prevention measures by using a membrane air dryer (such as series IDG).

Caution

1. Quality of operating air

- Be sure to use only air filtrated by a micro mist separator (such as AMD series). Use of a super mist separator (such as AME series) is recommended to extend maintenance intervals.
- Use of humid air may cause condensation inside the body. Use air which has been treated by a refrigerated air dryer (such as IDF series).
- If a pump is operated by N₂ gas, etc., the deterioration of the gaskets inside the switching valve will be accelerated and may result in substantially shortening the life span of the product.

2. Compressed air with low dew point

If compressed air with an atmospheric pressure dew point below -40°C is used, the lubrication properties inside the product can deteriorate prematurely, affecting the life of the product.

When air with an atmospheric pressure dew point below -40°C is used for the operating environment or operating fluid, it is recommend that the customer tests the product under their own specific operating conditions.

5. Operating Environment

Warning

1. Do not use in the following environments, as this can cause failure.

- 1) Locations with an atmosphere of corrosive gases, organic solvents or chemical solutions, and where there may be contact with the same.
- 2) Locations where there is contact with sea spray, water or steam.
- 3) Locations where ultraviolet deterioration or overheating of resin may occur due to direct sunlight.
- 4) Locations near heat sources with poor ventilation (heat sources should be shielded by heat insulating material).
- 5) Locations with impact or vibration.
- 6) Locations with excessive moisture and dust.

2. The product cannot be used under water.

Do not use the product immersing it in water (liquid). Otherwise, liquid will enter the openings inside the product, resulting in a malfunction.

3. Depending on the fluid used, a flammable atmosphere may occur. Take countermeasures such as ventilation.

6. Maintenance

Warning

1. Perform maintenance after consulting the operation manual.

Obtain the operation manual for the equipment from SMC or our distributor and have sufficient knowledge of the equipment before performing maintenance. Incorrect handling may cause damage or malfunction of the equipment or system.

2. Perform maintenance work after confirming the safety of the system.

Turn off the compressed air and power supply and exhaust any remaining compressed air in the system before removing the equipment and the compressed air supply/exhaust unit. Discharge the residual liquid or sufficiently displace it as necessary. Also, when reinstalling the equipment or restarting it after replacement, confirm the safety of the product before checking that it operates normally.

3. Use appropriate protective equipment.

When touching the process pump for maintenance, wear protective equipment such as gloves which are compatible with the fluid used. There is a risk of chemical burns.

4. Do not disassemble the product, as disassembly will invalidate the product's warranty.

5. Drain discharge

Operating the system with drain accumulated in the equipment or piping may cause a malfunction of the equipment, splash over into the downstream side, or unexpected accident. Periodically discharge drain from components including the air filter.

6. Caution when transferring a high-temperature fluid

The product itself will become hot due to the high-temperature fluid. Since touching the product directly may cause burns, allow sufficient time for the product to cool down when transferring a high-temperature fluid. The measurement of the product temperature is recommended to confirm the safety of the system before performing work.

Caution

1. Caution when transferring a highly penetrating liquid

When transferring a liquid that is highly penetrating through fluoropolymer, components of the transferred liquid may enter the openings inside the equipment. Also, they may become attached to the external surface of the equipment. In this case, take the same measures as handling the transferred liquid.

2. Service life of diaphragm and maintenance of consumable items

- If the operating cycle of the process pump exceeds the service life of diaphragm, the diaphragm may be damaged due to deterioration. If it is damaged, the fluid will leak from the pilot air exhaust port and the air will blow out into the liquid circuit. Consider the pump operation (breathing, decline of discharge pressure, etc.) and the reference service life of diaphragm, and replace with new process pump or conduct necessary maintenance as early as possible.
- Items such as check valves may experience a malfunction earlier than the diaphragm depending on the operating conditions. Replacement of the whole product or maintenance should be performed as soon as possible.
- When conducting maintenance, obtain the necessary parts indicated in the maintenance parts list (P.19), and perform work according to the maintenance and operation manuals.

3. Please understand the following concerning the inability to repair the product.

- To enable the process pump to be used with various fluids, please note that from the aspects of ensuring worker safety and also the facilities, SMC is unable to carry out repair.

[Calculation of reference service life (days) of diaphragm]

$$\text{Reference service life (days)} = \frac{B \text{ (Reference number of cycles in service life)}}{\text{Operating frequency of solenoid valve (Hz)} \times 60 \text{ (sec)} \times \text{Operating time per day (hour)} \times 60 \text{ (min)}}$$

Model	Operating Method	Diaphragm material	Amount of discharge per cycle A	Reference number of cycles in service life B	Volume inside pump (wetted part)
PB1011A	Built-in solenoid valve	PTFE	Approx. 0.004L	30 million cycles	Approx. 9mL
PB1013A	Air operated				

7. Lubrication

Caution

1. The pump can be used without lubrication.

8. Caution on Handling

Warning

1. Test before using with the actual equipment.

Test the pump before using it with the actual equipment. Even if there is no problem in a short-term test, the liquid may penetrate through the fluoropolymer diaphragm causing a malfunction in the pump air circuit.

2. Storage

In the case of long-term storage after use, first thoroughly remove the liquid, and clean and dry the inside to prevent deterioration of the pump materials.

3. After a long period of non-use, perform a trial run prior to operation.

4. Ensure that the bolts are not loose before operating the process pump.

5. Adjustment of the discharge amount

Connect the discharge volume adjustment valve (throttle) to the FLUID OUT port of the process pump. Adjust the volume by adjusting the opening of the valve.

6. When the discharge volume is large (flow velocity is high) depending on the fluid type and operating conditions, cavitation may lead to poor operation or failure. Increase supply air pressure or decrease the discharge volume with a throttle so that cavitation is not generated.

7. Operating environment

When dangerous fluid is used, take measures to isolate humans from the pump. External leakage of pumping fluid could cause serious injury.

8. Countermeasures against liquid leakage

There are some cases where the operating fluid will leak outside the pump, for example when the diaphragm reaches the end of the life. Measures should be taken to avoid leakage, such as installing a drain pan, so that people and equipment will not be adversely affected.

9. Caution for piping of the tube

Support the piping according to JIS B 8370 when piping the tube. Arrange the piping so that tension is not applied to the tube.

9. Return of Product

Warning

If the product to be returned is contaminated or is possibly contaminated with substances that are harmful to humans, for safety reasons, please contact SMC beforehand and then employ a specialist cleaning company to decontaminate the product. After the decontamination prescribed above has been carried out, submit a Product Return Request Sheet or the Detoxification/Decontamination Certificate to SMC and await SMC's approval and further instructions before attempting to return the item.

Please refer to the International Chemical Safety Cards (ICSC) for a list of harmful substances.

Applicable Fluids

Material and Fluid Compatibility Check List for Process Pumps

- The data below is prepared based on data provided by the material manufacturers.
- SMC assumes no responsibility for the accuracy of the data or for any damages arising from the data.
- The material and fluid compatibility check list provides reference values as a guide only; therefore SMC does not guarantee the application to our product.

Caution

- Select the wetted parts materials according to the transfer liquid you use to determine the model.
 - For the diaphragm material, PTFE is suitable for non-permeating liquids.
 - Use fluids that will not corrode the wetted parts materials.
- These products are not suitable for medical or food use.
- The applicability may vary depending on additives. Take note also of additives.
- The applicability may vary depending on impurities. Take note also of impurities.
- Examples of transfer liquids are shown below. Since the applicability may vary depending on your operating conditions, be sure to check it by means of experimentation.
- Compatibility is indicated for fluid temperatures specified for the respective products (50°C or less).

Table symbols ○: Can be used. ×: Cannot be used. —: Can be used under certain conditions.

Model		PB1011A	PB1013A
Body material		PP, SUS316	
Diaphragm material		PTFE	
Examples of applicable liquids	Tap water	○	
	Neutral detergent	○	
	Kerosene	×	○ Note 1)
	Oils	×	○
	Ethyl alcohol	×	○ Note 1)
	Isopropyl alcohol	×	○ Note 1, 2)
	Thinners	×	
	Flammable liquids	×	—
	Acids	×	
	Alkalis	×	

Note 1) Static electricity may be generated. Take measures to prevent static electricity.

Note 2) These may be penetrated by fluids, and the penetrating fluids may affect parts of other materials.

Caution

Caution for transferring highly penetrating liquids

Do not use liquids which are highly penetrating to fluorine resin. This may cause internal damage to the process pump or liquid leakage.

Specifications

Model			PB1011A	PB1013A
Actuation			Built-in solenoid valve	Air operated
Port size	Main fluid suction discharge port		Rc, NPT, G 1/8" Female thread	
	Pilot air	Supply port	Rc, NPT, G 1/8" Female thread	
		Exhaust port	M5 x 0.8 female thread	—
Material	Body wetted parts		Polypropylene (PP), Stainless steel (SUS316)	
	Diaphragm		PTFE	
	Check valve		PTFE, Polypropylene (PP)	
	Liquid contact seals		FKM	
Discharge rate ^{Note 1)}			8 to 2000 mL/min	8 to 1000 mL/min ^{Note 2)}
Average discharge pressure			0 to 0.6 MPa	
Pilot air pressure			0.2 to 0.7 MPa	
Air consumption			40 L/min (ANR) or less	
Suction lifting range ^{Note 1)}			Up to 2.5 m (dry state inside the pump)	
Noise			64 dB (A) or less (Option: With silencer AN120-M5)	
Withstand pressure			1.05 MPa	
Diaphragm life (Reference)			30 million times	
Fluid temperature			0 to 50° C (No freezing, heat cycle not applied)	
Ambient temperature			0 to 50° C (No freezing, heat cycle not applied)	
Recommended operating cycle			1 to 10 Hz	
Pilot air solenoid valve recommended Cv value			—	0.2 ^{Note 3)}
Weight			0.18 kg	0.11 kg
Mounting orientation			FLUID OUT port upside	
Packaging			General environment	
Maximum viscosity			100 mPa·s	
Power supply voltage			24 VDC	—
Power consumption			0.35 W	—

* Each of the values above are for normal temperatures and clear water.

* Faulty sealing of the check valves or accumulation of dust may cause operation to stop, so slurry processing is not available.

Note 1) The values given for discharge and suction head are for no piping. Values will depend on piping conditions.

Note 2) Applicable up to 2000 mL/min by using a solenoid valve with a large Cv value (Cv value of 0.5 or more).

Note 3) With low operating cycles, even a valve with a small Cv value can be operated.

Performance Curve

Flow Rate Characteristics

PB1011A

Cycle (1 Hz)

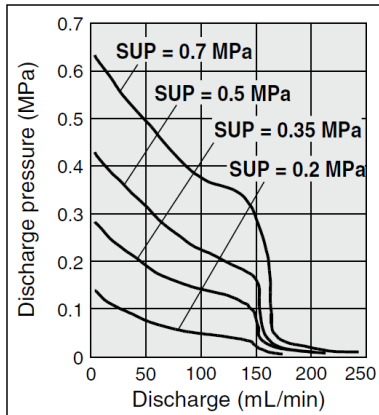

Cycle (5 Hz)

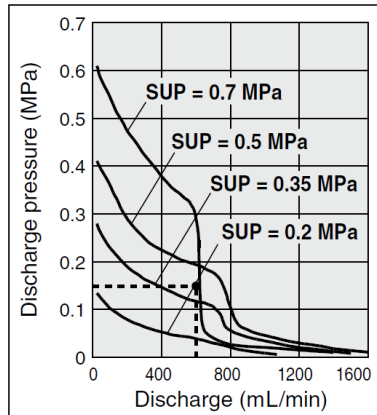

Cycle (7 Hz)

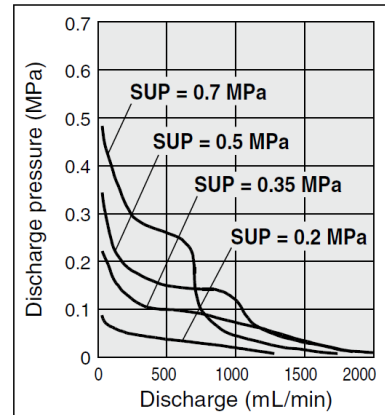

PB1013A

Cycle (1 Hz)

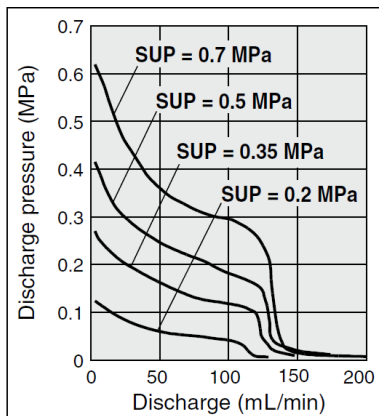

Cycle (5 Hz)

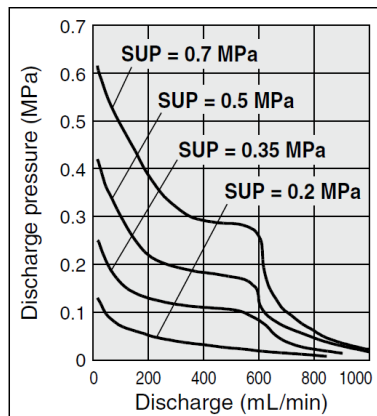

Cycle (7 Hz)

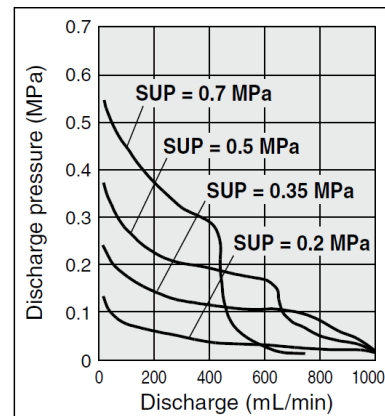

Selection from Flow Rate Characteristic Graph

Required specification example:

Find the pilot air pressure for a discharge rate of 600 mL/min and a discharge pressure of 0.15 MPa for builtin solenoid valve type.

<The transferred fluid is clear water (viscosity of 1 mPa·s, specific gravity of 1.0) and solenoid valve cycle is 5 Hz.>

* When the total pump head is required instead of the discharge pressure, a discharge pressure of 0.1 MPa corresponds to a total pump head of 10 m.

Selection procedures:

1. First, mark the intersection point for a discharge rate of 600 mL/min and a discharge pressure of 0.15 MPa.
2. Find the pilot air pressure for the marked point. In this case, the point is between the discharge curves for 0.35 MPa and 0.5 MPa, and based on the proportional relationship to these lines, the pilot air pressure for this point is approximately 0.4 MPa.

Caution

1. Flow rate characteristics are for clear water (viscosity of 1 mPa·s, specific gravity of 1.0), no piping for suction and discharge.
2. The amount of discharge differs greatly depending on properties (viscosity, specific gravity) of the fluid being transferred and operating conditions (pump head, transfer distance), etc.

Air Consumption

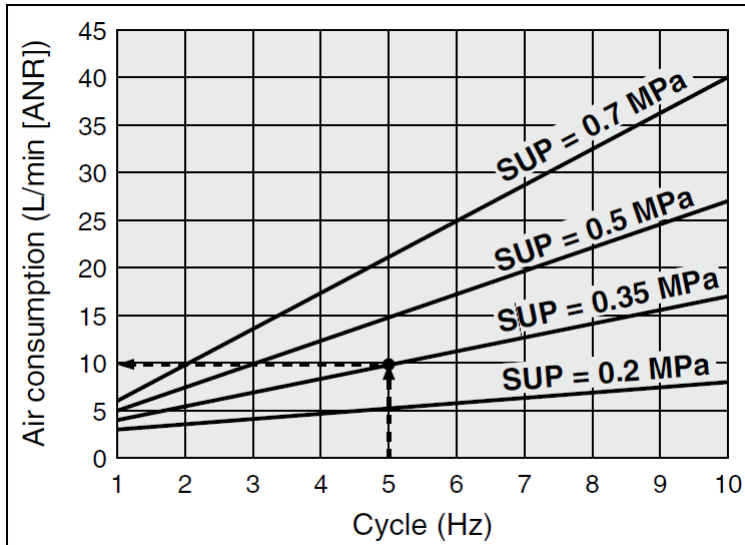

Calculating Air Consumption

Find the air consumption for operation with a 5 Hz switching cycle and pilot air pressure of 0.35 MPa from the air consumption graph.

Selection procedures:

1. Look up from the 5 Hz switching cycle to find the intersection with SUP = 0.35 MPa.
2. From the point just found, draw a line to the Y-axis to find the air consumption. The result is approximately 10 L/min (ANR).

Caution

1. The air consumption differs greatly depending on properties (viscosity, specific gravity) of the transferred fluid and operating conditions (pump head, transfer distance), etc.

Viscosity Characteristics

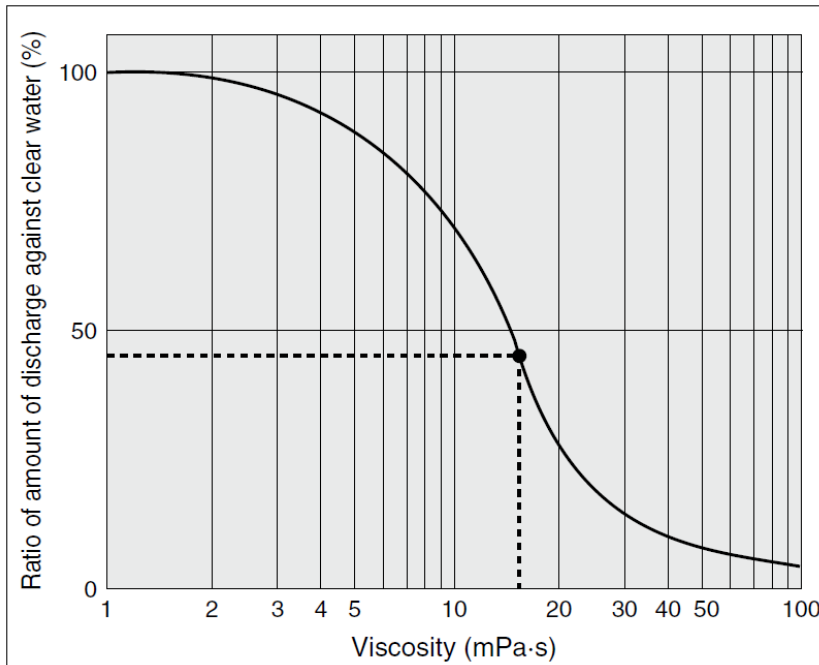

Selection from Viscosity Characteristic Graph

Required specifications example:

Find the pilot air pressure and pilot air consumption for a discharge rate of 270 mL/min, discharge pressure of 0.15 MPa, and a viscosity of 15 mPa·s.

Selection procedures:

1. First, find the ratio of the amount of discharge against clear water when viscosity is 15 mPa·s from the graph to the left. It is determined to be 45%.
2. Next, the viscosity of 15 mPa·s and the discharge rate of 270 mL/min in the required specification example are converted to the amount of discharge for clear water.
Since 45% of the clear water discharge is equivalent to 270 mL/min in the required specifications, $270 \text{ mL/min} \div 0.45 = \text{approximately } 600 \text{ mL/min}$, indicating that a discharge rate of 600 mL/min is required for clear water.
3. Finally, find the pilot air pressure and pilot air consumption based on the flow rate characteristic graphs.

Caution

Viscosities up to 100 mPa·s can be used.

The following equation shows the relationship between the kinematic viscosity and the dynamic viscosity.

$$\text{Kinematic viscosity } \nu \text{ [m}^2\text{/s]} = \frac{\text{Viscosity } \mu \text{ [Pa}\cdot\text{s]}}{\text{Density } \rho \text{ [kg/m}^3\text{]}}$$

The commonly used unit system is

$$\text{Kinematic viscosity } \nu \text{ [cSt]} = \frac{\text{Viscosity } \mu \text{ [mPa}\cdot\text{s]}}{\text{Density } \rho \text{ [g/cm}^3\text{]}}$$

In addition, 1 [mPa·s] = 1 [cP].

Maintenance Parts



- Basically, it is not recommended to disassemble the process pump. However, if this is necessary, be sure to follow the instructions in the maintenance procedure.
- When carrying out this work, wear appropriate protective equipment.

Description	PB1011A	PB1013A
Diaphragm kit	KT-PB1A-9	KT-PB1A-2
Check valve kit	KT-PB1A-1	
Port set	KT-PB1A-7□ ^{Note)}	
Packing kit	KT-PB1A-4	
Foot kit	KT-PB1-3	KT-PB1A-5
Solenoid valve kit	SYJ314M-5H-Q	—

Note) One of Nil, F or N is entered as a thread symbol.

Dimensions

Built-in Solenoid Valve PB1011A

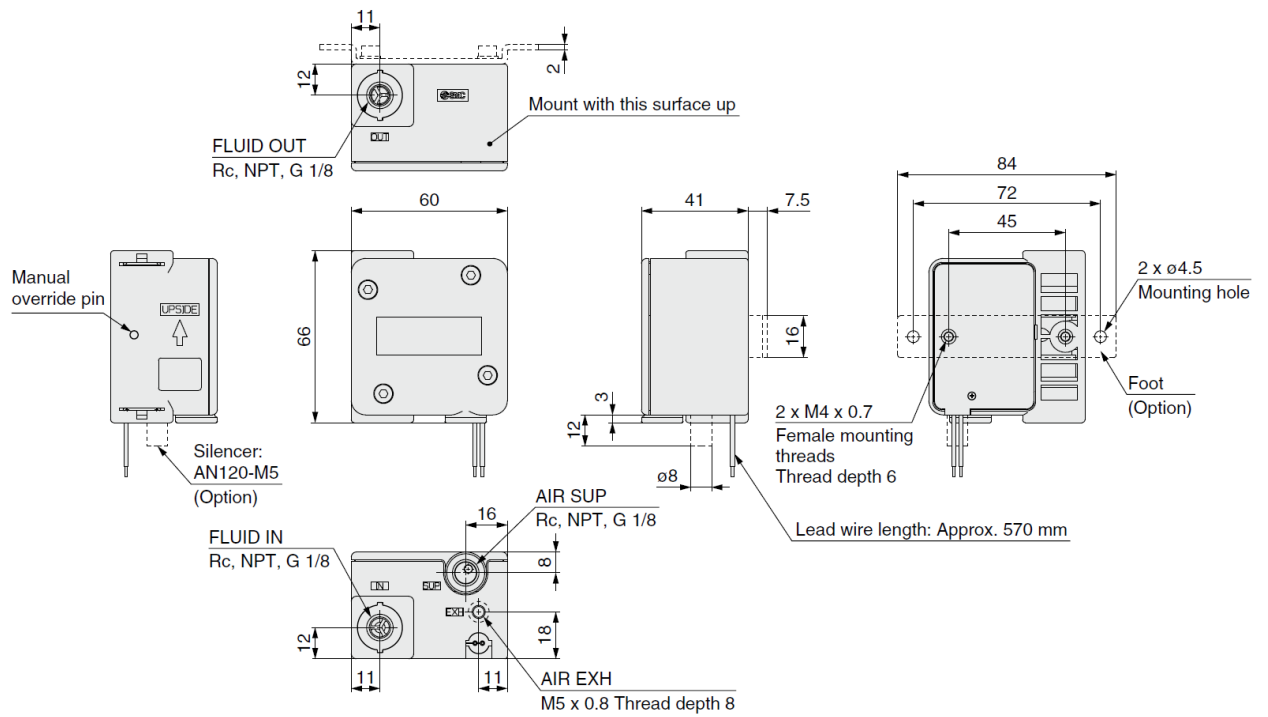

Air Operated PB1013A

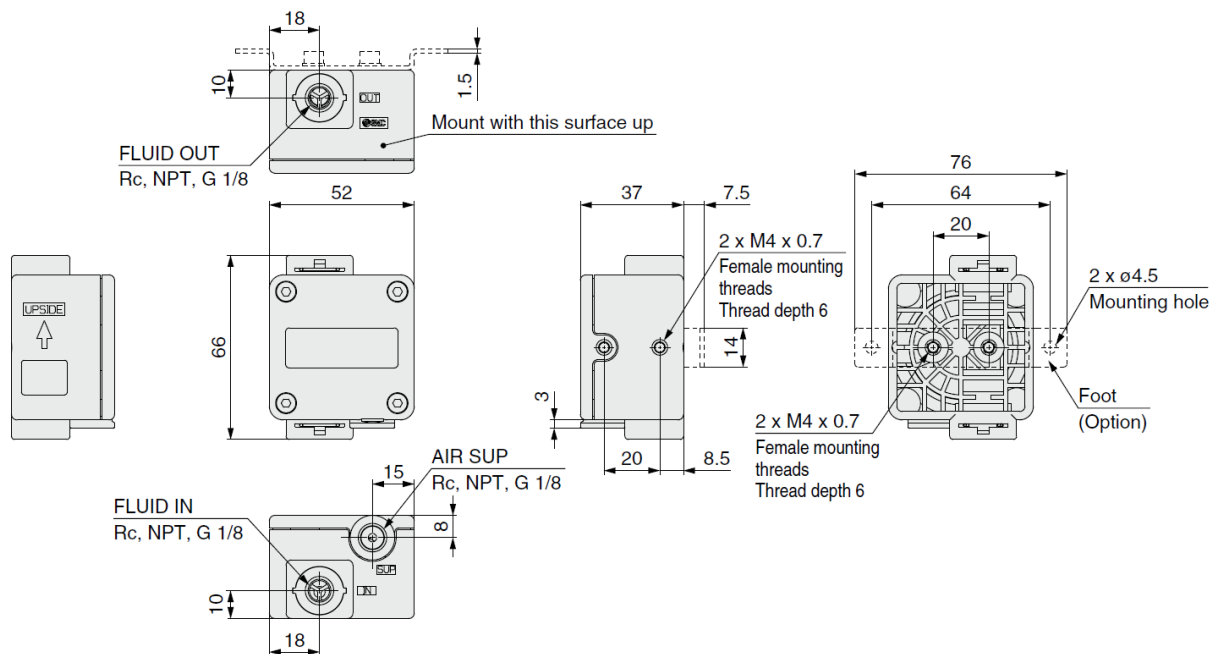

Troubleshooting

If any abnormality is found, perform checks according to the following list

Warning

- Discharge dangerous fluid from the pump.
- Do not return the pump with dangerous fluid left in it. If the product is to be returned, please refer to the 9. Return of Products on page 13.

Phenomenon		Possible cause	Remedy
Supply of air cannot move the pump.		- Operation failure of the solenoid valve.	- Replace the solenoid valve with a new one.
The pump starts, but does not discharge fluid.	The pump does not suck fluid.	<ul style="list-style-type: none"> - The check valve is clogged. - The check valve is damaged or worn out. - The filter at suction side (IN port) is clogged. - Excessive suction pump head. - Incorrect mounting direction. - The diaphragm is damaged or coming off. - Sealing failure of fitting at suction side (IN port). - Excessive viscosity of transported fluid. 	<ul style="list-style-type: none"> - Cleaning - Replace the pump. - Clean the filter. - Reduce within self suction capacity. - Correct to normal mounting direction. - Replace the pump. - Ensure sufficient sealing. - Non-conformance.
	The pump sucks, but does not discharge.	- Check valve or fitting at discharge side (OUT port) is clogged.	- Cleaning
The discharge amount is insufficient.		<ul style="list-style-type: none"> - Check valve at suction side (IN port) or discharge side (OUT port) is clogged. - Excessive viscosity of transported fluid. - Large suction or discharge pump head. - The filter of suction side (IN port) is clogged. - The filter of discharge side (OUT port) is clogged. - Insufficient air supply. - Too small port size of transported fluid piping. - Back pressure is applied from the discharge side (OUT port). 	<ul style="list-style-type: none"> - Cleaning - Non-conformance - Reduce the pump head. - Clean or replace the filter. - Clean or replace the filter. - Supply air at adequate pressure. - Increase the air supply. - Remove the back pressure or increase the air supply pressure.

Phenomenon	Possible cause	Remedy
A lot of air bubbles come out from the discharge side (OUT port).	<ul style="list-style-type: none"> - Air is sucked from the suction side (IN port). - Sealing failure of fitting at suction side (IN port). - Damaged diaphragm 	<ul style="list-style-type: none"> - Prevent suction. - Ensure sufficient sealing. - Replace the pump.
Transported fluid flows out from exhaust port. (EXH port)	<ul style="list-style-type: none"> - Damaged diaphragm 	<ul style="list-style-type: none"> - Replace the pump.
Transported fluid or air leaks from jointed part to outside.	<ul style="list-style-type: none"> - Damaged diaphragm - Swelling, contraction, and deterioration of the sealing. - Excess supply air pressure 	<ul style="list-style-type: none"> - Replace the pump. - Replace the pump. - Supply air at appropriate pressure.

Revision history	
2011-04-06	Initial release
2024-10-30	Rev. A

SMC Corporation

Tel: + 81 3 5207 8249 Fax: +81 3 5298 5362
URL <https://www.smcworld.com>

Note: Specifications are subject to change without prior notice and any obligation on the part of the manufacturer.
© SMC Corporation All Rights Reserved