



Operation Manual

PRODUCT NAME

Process Pump

MODEL / Series / Product Number

PAF3410-□03

PAF3410-P13□

PAF3410S-□S□□

SMC Corporation

Contents

Safety Instructions	2
Model Indication and How to Order	4
Names and Functions of Product Parts	5
Piping and Operation	6
Working Principle	7
Precautions	8
1. Caution on Design	8
2. Mounting	9
3. Piping	10
4. Air supply	10
5. Operating Environment	11
6. Maintenance	11
7. Lubrication	12
8. Caution on Handling	13
9. Return of Product	13
Applicable Fluids	14
Specifications	15
Performance Curve	16
Flow Rate Characteristics	16
Air Consumption	16
Viscosity Characteristics	17
Maintenance Parts	18
Dimensions	19
Sensor mounting (leakage sensor)	21
Troubleshooting	22



Safety Instructions

These safety instructions are intended to prevent hazardous situations and/or equipment damage. These instructions indicate the level of potential hazard with the labels of “**Caution**,” “**Warning**” or “**Danger**.” They are all important notes for safety and must be followed in addition to International Standards (ISO/IEC)^{*1)}, and other safety regulations.

*1) ISO 4414: Pneumatic fluid power - General rules and safety requirements for systems and their components
ISO 4413: Hydraulic fluid power - General rules and safety requirements for systems and their components
IEC 60204-1: Safety of machinery - Electrical equipment of machines - Part 1: General requirements
ISO 10218-1: Robots and robotic devices - Safety requirements for industrial robots - Part 1: Robots
etc.



Danger

Danger indicates a hazard with a high level of risk which, if not avoided, will result in death or serious injury.



Warning

Warning indicates a hazard with a medium level of risk which, if not avoided, could result in death or serious injury.



Caution

Caution indicates a hazard with a low level of risk which, if not avoided, could result in minor or moderate injury.

Warning

1. The compatibility of the product is the responsibility of the person who designs the equipment or decides its specifications.

Since the product specified here is used under various operating conditions, its compatibility with specific equipment must be decided by the person who designs the equipment or decides its specifications based on necessary analysis and test results. The expected performance and safety assurance of the equipment will be the responsibility of the person who has determined its compatibility with the product. This person should also continuously review all specifications of the product referring to its latest catalog information, with a view to giving due consideration to any possibility of equipment failure when configuring the equipment.

2. Only personnel with appropriate training should operate machinery and equipment.

The product specified here may become unsafe if handled incorrectly. The assembly, operation and maintenance of machines or equipment including our products must be performed by an operator who is appropriately trained and experienced.

3. Do not service or attempt to remove product and machinery/equipment until safety is confirmed.

1. The inspection and maintenance of machinery/equipment should only be performed after measures to prevent falling or runaway of the driven objects have been confirmed.
2. When the product is to be removed, confirm that the safety measures as mentioned above are implemented and the power from any appropriate source is cut, and read and understand the specific product precautions of all relevant products carefully.
3. Before machinery/equipment is restarted, take measures to prevent unexpected operation and malfunction.

4. Our products cannot be used beyond their specifications. Our products are not developed, designed, and manufactured to be used under the following conditions or environments. Use under such conditions or environments is not covered.

1. Conditions and environments outside of the given specifications, or use outdoors or in a place exposed to direct sunlight.
2. Use for nuclear power, railways, aviation, space equipment, ships, vehicles, military application, equipment affecting human life, body, and property, fuel equipment, entertainment equipment, emergency shut-off circuits, press clutches, brake circuits, safety equipment, etc., and use for applications that do not conform to standard specifications such as catalogs and operation manuals.
3. Use for interlock circuits, except for use with double interlock such as installing a mechanical protection function in case of failure. Please periodically inspect the product to confirm that the product is operating properly.



Safety Instructions

Caution

We develop, design, and manufacture our products to be used for automatic control equipment, and provide them for peaceful use in manufacturing industries.

Use in non-manufacturing industries is not covered.

Products we manufacture and sell cannot be used for the purpose of transactions or certification specified in the Measurement Act.

The new Measurement Act prohibits use of any unit other than SI units in Japan.

Limited warranty and Disclaimer/Compliance Requirements

The product used is subject to the following “Limited warranty and Disclaimer” and “Compliance Requirements”.

Read and accept them before using the product.

Limited warranty and Disclaimer

1. The warranty period of the product is 1 year in service or 1.5 years after the product is delivered, whichever is first.*2)

Also, the product may have specified durability, running distance or replacement parts. Please consult your nearest sales branch.

2. For any failure or damage reported within the warranty period which is clearly our responsibility, a replacement product or necessary parts will be provided.

This limited warranty applies only to our product independently, and not to any other damage incurred due to the failure of the product.

3. Prior to using SMC products, please read and understand the warranty terms and disclaimers noted in the specified catalog for the particular products.

***2) Vacuum pads are excluded from this 1 year warranty.**

A vacuum pad is a consumable part, so it is warranted for a year after it is delivered.

Also, even within the warranty period, the wear of a product due to the use of the vacuum pad or failure due to

the deterioration of rubber material are not covered by the limited warranty

Compliance Requirements

1. The use of SMC products with production equipment for the manufacture of weapons of mass destruction (WMD) or any other weapon is strictly prohibited.

2. The exports of SMC products or technology from one country to another are governed by the relevant security laws and regulations of the countries involved in the transaction. Prior to the shipment of a SMC product to another country, assure that all local rules governing that export are known and followed.

Model Indication and How to Order

Female thread

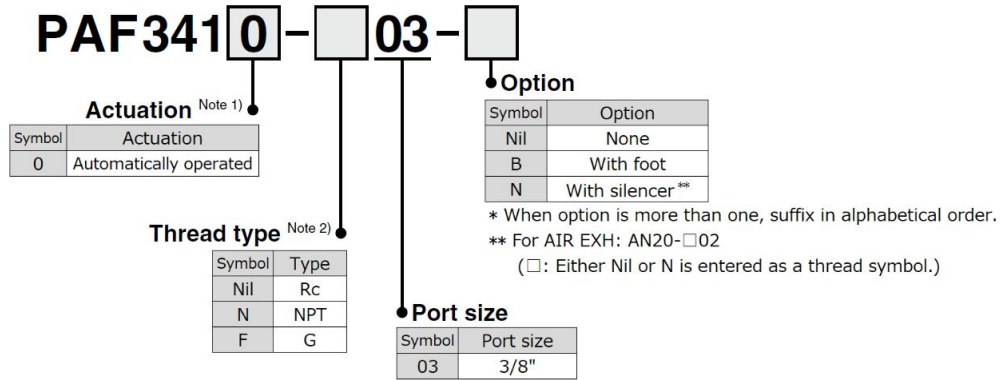

Tube extension

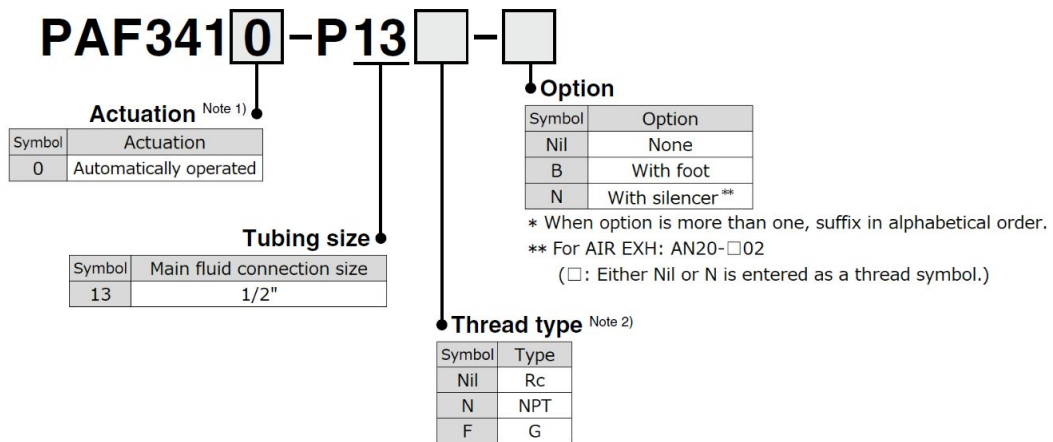

With nut

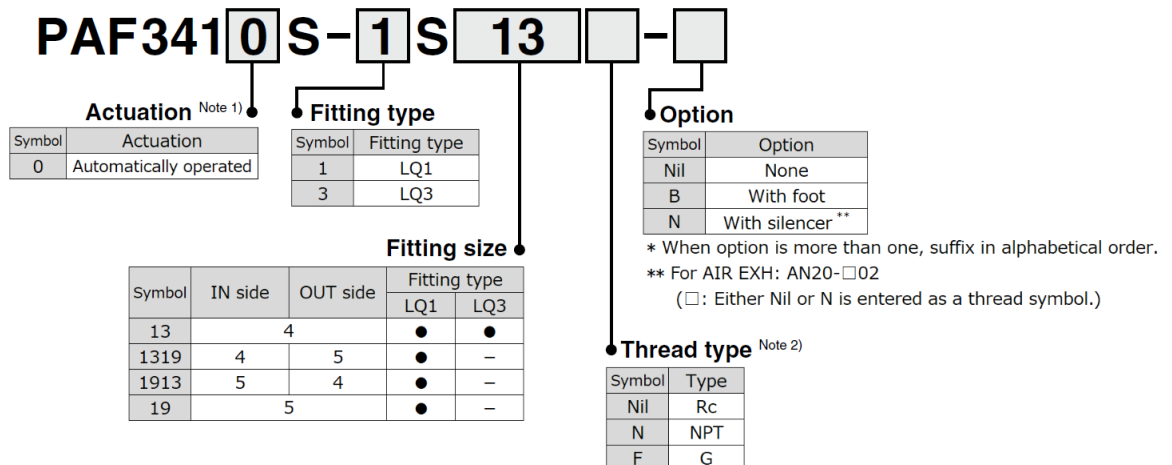

Note 1) The port size of the pilot port is as follows. Automatically operated type is 1/4"; Air operated type is 1/8".
 Note 2) The thread type is applied to the pilot port thread and the female thread piping connection.

Names and Functions of Product Parts

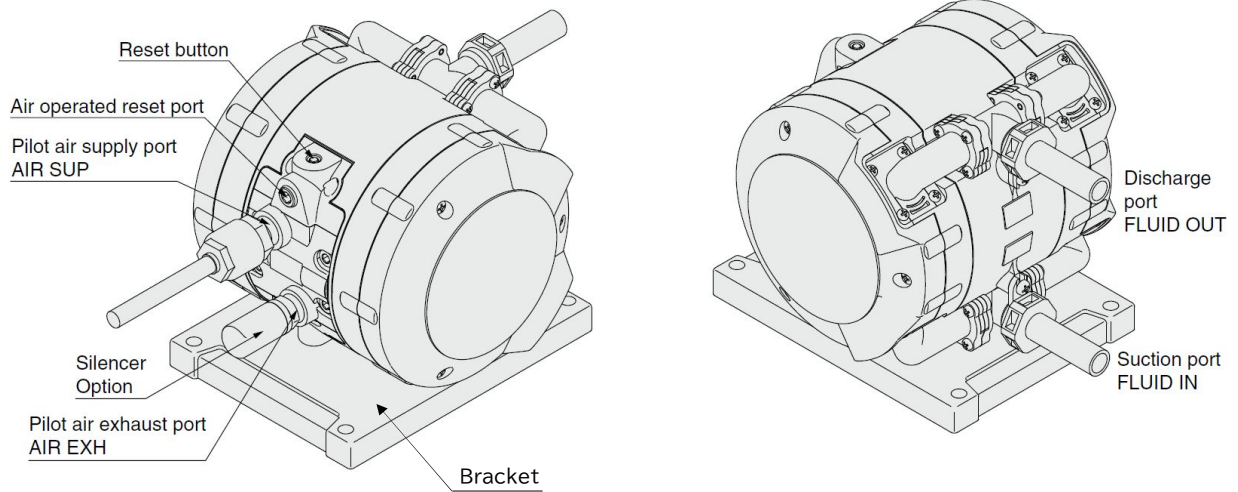

Description	Functions
Suction port (FLUID IN)	Sucks the fluid to be transferred. Connect suction piping.
Discharge port (FLUID OUT)	Discharges the fluid taken in the pump. Connect discharge piping.
Pilot air supply port (AIR SUP)	Supplies air of set pressure. Connect the air piping.
Pilot air exhaust port (AIR EXH)	Exhausts pilot air.
Reset button Air operated reset port	Resets the pump when operation is stopped.
Bracket	Holds the product.

Piping and Operation

⚠ Caution

Mounting posture of the pump is set with the mounting bracket facing downward. Air to be supplied to the air supply port <AIR SUP> should be cleaned and filtered through a filter, or a mist separator etc. Air with foreign matter or drainage etc. will have negative effects on the built-in solenoid valve and will lead to malfunction.

Maintain the proper tightening torque for fittings and mounting bolts, etc. Looseness can cause problems such as fluid and air leaks, while over tightening can cause damage to threads and parts, etc.

Starting and Stopping Refer to circuit example (1)

1. Connect air piping to the air supply port <AIR SUP> and connect piping for the fluid to be transferred to the suction port <FLUID IN> and the discharge port <FLUID OUT>.
2. Using a regulator, set the pilot air pressure within the range of 0.2 to 0.5 MPa. Then, the pump operates when power is applied to the 3 port solenoid valve of the air supply port <AIR SUP>, the sound of exhaust begins from the air exhaust port <AIR EXH> and fluid flows from the suction port <FLUID IN> to the discharge port <FLUID OUT>.

At this time, the throttle on the discharge side is in an open state. The pump performs suction with its own power even without priming. (Dry state suction lifting range: max. 1 m) To restrict exhaust noise, attach a silencer (AN20-02: option) to the air exhaust port <AIR EXH>.

3. To stop the pump, exhaust the air pressure being supplied to the pump by the 3 port solenoid valve of the air supply port <AIR SUP>. The pump stops even when the throttle on the discharge side is closed. But the pressure supply to the pump should be exhausted quickly.

Discharge Flow Rate Adjustment

1. To adjust the flow rate from the discharge port <FLUID OUT>, use the throttle connected to the discharge side. Refer to circuit example (1). Note that this product cannot be used as a fixed quantity liquid dispense pump.
2. When operating with a discharge flow rate below the specification range, provide a by-pass circuit from the discharge side to the suction side to ensure the minimum flow rate inside the process pump. With a discharge flow rate below the minimum flow rate, the process pump may stop due to unstable operation. Refer to circuit example (2). (Minimum flow rates: 1 L/min)

< Reset Button >

When the pump stops during operation, press the reset button. This makes it possible to restore operation in case the switching valve becomes clogged due to foreign matter in the supply air.

< Air Operated Reset Port >

It is possible to restore operation by supplying air to the air operated reset port without directly pressing the reset button, such as by remote control. Pressure equivalent to or greater than pilot air pressure (but less than 0.5 MPa) is required to reset air. Refer to circuit example (3).

< Counting The Operating Cycle >

The pump's operating cycle can be counted by applying a pressure switch to the air operated reset port. Keep the distance between the pressure switch and the air operated reset port within 50 mm. Refer to circuit example (3).

Circuit example (1)

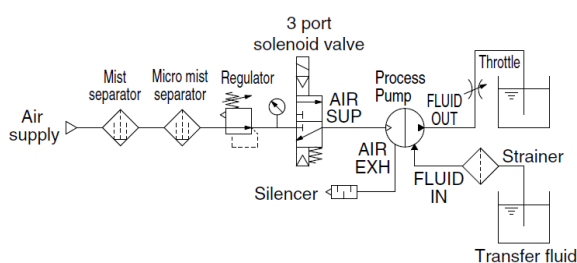

Circuit example (2)

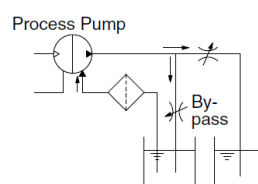

Circuit example (3)

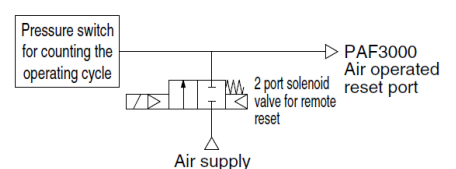

Working Principle

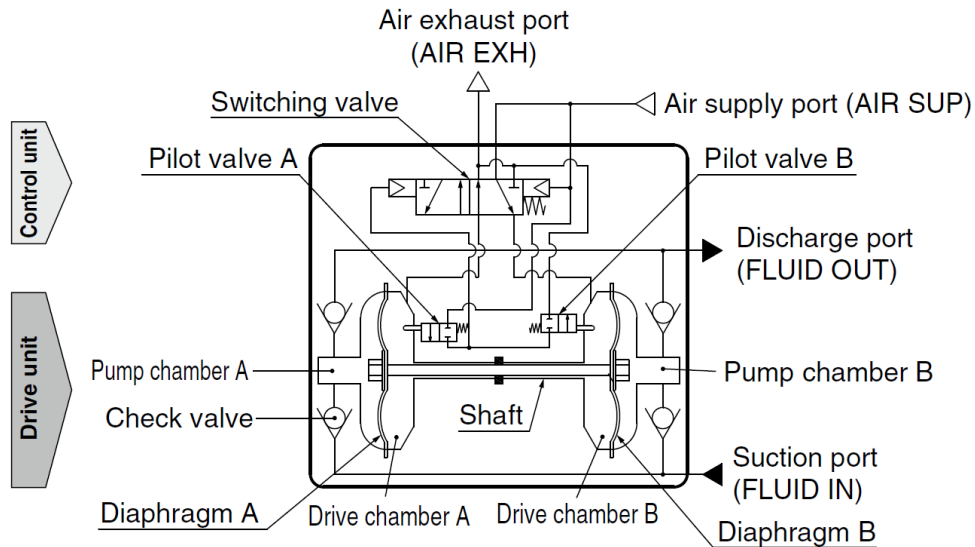

Control unit

1. When air is supplied, it passes through the switching valve and enters drive chamber B.
2. Diaphragm B moves to the right, and at the same time diaphragm A also moves to the right pushing pilot valve A.
3. When pilot valve A is pushed, air acts upon the switching valve, drive chamber A switches to a supply state, and the air which was in drive chamber B is exhausted to the outside.
4. When air enters drive chamber A, diaphragm B moves to the left pushing pilot valve B.
5. When pilot valve B is pushed, the air which was acting upon the switching valve is exhausted, and drive chamber B once again switches to a supply state. A continuous reciprocal motion is generated by this repetition.

Drive unit

1. When air enters drive chamber B, the fluid in pump chamber B is forced out, and at the same time fluid is sucked into pump chamber A.
2. When the diaphragm moves in the opposite direction, the fluid in pump chamber A is forced out, and fluid is sucked into pump chamber B.
3. Continuous suction and discharge is performed by the reciprocal motion of the diaphragm.

Precautions

1. Caution on Design

Warning

1. Confirm the specifications.

- Give careful consideration to operating conditions such as the application, fluid and environment, and use the product within the operating ranges specified in this catalog.
- The product is provided for physical, chemical and industrial equipment.

2. Fluids

- When ignitable fluid is used, select a product with metal wetted parts (aluminum, stainless steel). Always take countermeasures against static electricity.
- For the compatibility between the materials composing the product and the fluids, check the compatibility check list. Since the compatibility of the fluid used may vary depending on its type, additives, concentration, temperature, etc., give sufficient consideration when selecting the material.
- Use within the range of the operating fluid temperatures.
- If foreign matter is mixed in the fluid, these may cause abrasion of the inside of the pump resulting in a problem. Use an appropriate filter (strainer) to remove them. In general, 80 to 100 mesh (150 to 180 μ m) filters are recommended.
- When transferring a coagulable liquid, take measures to prevent it from coagulating in the pump.
- Use of slurry is not recommended.
- Take countermeasures to prevent the operating fluid from getting onto the body of the process pump.

3. Water hammer

If a valve is operated abruptly etc., a high pressure may be applied due to water hammer. Take measures to prevent pressures higher than specified from being applied.

<Examples of measures>

- Use a water hammer resistant valve to reduce the valve closing speed.
- Use an elastic piping material such as rubber hose or an accumulator to absorb the impact pressure.

4. Liquid seals

To ensure that fluid does not become sealed inside the process pump, when stopping the pump, relieve the discharge pressure inside it. As shown in the figure at right, make a circuit which has a relief valve installed on the system.

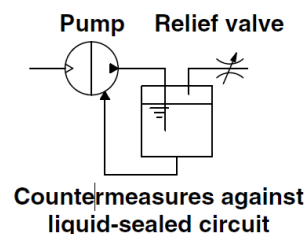

5. Fluid pressure supplied to the process pump

Feeding the fluid from the suction side into the pump under pressure, or drawing it using a negative pressure, will reduce the life of the pump.

6. Ensure space for maintenance.

Secure the space required for maintenance and inspection. Take into consideration also leakage from the product. When transferring a flammable liquid or a liquid that may affect the human body or environment, take measures including fire ban and keeping the area off limits.

7. When the diaphragm is broken, supply air will be mixed with the fluid or fluid will enter the air switching valve. When the supply air or debris contained in it affect the product performance, or the supply air is not suitable for the chemical resistance of the components, countermeasures need to be taken by the customer.

8. Use a design which prevents reverse pressure and reverse flow.

If reverse pressure or reverse flow occurs on the discharge side of the process pump, the equipment is liable to become damaged or malfunction. Take safety measures in designing the circuit.

9. Measures against static electricity

Take measures against static electricity as static electricity may occur depending on the fluid. Particularly, when circulating flammable fluid through the pump, be sure to take measures to prevent the occurrence of static electricity.

10. The pump cannot transfer gas. Do not allow it to idle for a long time.

If the pump is operated for a long time without any fluid inside or in a gas-fluid mixed state, the diaphragm may be damaged or the life may be shortened. Dry operation is only allowed during self-priming.

11. Condensation and freezing of the pilot port

The location around the switching valve and the air exhaust port of the automatically operated type can cool down quickly due to expansion of the supply air, and this may cause condensation on the piping and the condensation may freeze during operation in winter. Take measures to ensure that water droplets from condensation are not splashed onto any electric parts or equipment.

Caution

1. Suspension of the pump operation

Use a 3-port solenoid valve and be sure to discharge the residual pressure. If the process pump is stopped while air is still being supplied to it, a load will be applied to the internal parts of the pump, reducing the life of the pump. Also, if the pump should stop while consuming the residual pressure, the built-in pilot air switching unit may become unstable and unable to be restarted. If it cannot be restarted, press the reset button.

2. Use the constant pilot air pressure.

The automatically operated type of some models adopts an air spring for the built-in air control circuit, and the pump may malfunction and stop when the pilot air pressure fluctuation exceeds 50 kPa.

3. Reverse flow

The check valve inside the process pump does not completely stop reverse flow (the flow from the discharge side to the suction side). For this reason, fluid may sometimes flow from the discharge side to the suction side when the pump is stationary, etc). As a countermeasure, install a 2-way valve or a check valve. However, please note that when a check valve is installed, if the cracking pressure is high, defective suction may occur. (As a guide, the cracking pressure should be 0.02 MPa or less.)

2. Mounting

Caution

1. Read the operation manual before mounting the product.

Read the operation manual carefully and understand the contents before mounting the product. The manual should also be kept where it can be referred to whenever necessary.

2. Open the sealed package inside a clean room.

Products specified for clean room are sealed and double packaged inside a clean room. We recommend that the inner package should be opened inside a clean room or clean environment.

3. Confirm the mounting orientation of the product.

Only horizontal mounting is available. Attach the product so that the mounting feet face down. When the foot is not used, install the foot so that the foot mounting surface is on the face down.

Also, secure all specified mounting positions when using the product.

If the propagation of the vibration of the pump is not acceptable, insert vibro-isolating rubber when mounting.

3. Piping

Caution

1. Flush the piping.

Flush and clean the piping before connecting the product. Any dirt or scale and the like left in the piping may cause malfunction or failure.

2. Use fittings with resin threads when connecting piping to the product with resin threads at the ports.

Using fittings with metal threads may cause damage to the ports.

3. Tighten screws with proper tightening torque.

When screwing fittings into the product, tighten them with proper tightening torque as shown below. If loose, liquid or air leakage may occur. If overtightened, the threaded parts may be damaged.

Connection thread	Proper tightening torque [N·m]	Port names
Rc, NPT, G 1/8"	0.4 to 0.5	Air operated reset port
Rc, NPT, G 1/4"	0.8 to 1	AIR SUP, AIR EXH
Rc, NPT, G 3/8"	2 to 2.5	FLUID IN, FLUID OUT

4. Air supply

Warning

1. Use clean air.

Do not use compressed air that includes chemicals, synthetic oils containing organic solvents, salinities or corrosive gases, etc., as it can cause damage or malfunction.

2. Pay attention to avoid freezing when operating the product in low temperatures.

The equipment operates while expanding the compressed air. During this time, the temperature inside the product decreases due to adiabatic expansion. If the ambient temperature is low, using compressed air containing a lot of moisture may cause freezing because heat cannot be gained from the surroundings. In this case, take freeze prevention measures by using a membrane air dryer (such as series IDG).

Caution

1. Quality of operating air

- Be sure to use only air filtrated by a micro mist separator (such as AMD series). Use of a super mist separator (such as AME series) is recommended to extend maintenance intervals.
- Use of humid air may cause condensation inside the body. Use air which has been treated by a refrigerated air dryer (such as IDF series).
- If a pump is operated by N₂ gas, etc., the deterioration of the gaskets inside the switching valve will be accelerated and may result in substantially shortening the life span of the product.

2. Compressed air with low dew point

If compressed air with an atmospheric pressure dew point below -40°C is used, the lubrication properties inside the product can deteriorate prematurely, affecting the life of the product.

When air with an atmospheric pressure dew point below -40°C is used for the operating environment or operating fluid, it is recommend that the customer tests the product under their own specific operating conditions.

5. Operating Environment

Warning

1. Do not use in the following environments, as this can cause failure.

- 1) Locations with an atmosphere of corrosive gases, organic solvents or chemical solutions, and where there may be contact with the same.
- 2) Locations where there is contact with sea spray, water or steam.
- 3) Locations where ultraviolet deterioration or overheating of resin may occur due to direct sunlight.
- 4) Locations near heat sources with poor ventilation (heat sources should be shielded by heat insulating material).
- 5) Locations with impact or vibration.
- 6) Locations with excessive moisture and dust.

2. The product cannot be used under water.

Do not use the product immersing it in water (liquid). Otherwise, liquid will enter the openings inside the product, resulting in a malfunction.

3. Depending on the fluid used, a flammable atmosphere may occur. Take countermeasures such as ventilation.

6. Maintenance

Warning

1. Perform maintenance after consulting the operation manual.

Obtain the operation manual for the equipment from SMC or our distributor and have sufficient knowledge of the equipment before performing maintenance. Incorrect handling may cause damage or malfunction of the equipment or system.

2. Perform maintenance work after confirming the safety of the system.

Turn off the compressed air and power supply and exhaust any remaining compressed air in the system before removing the equipment and the compressed air supply/exhaust unit. Discharge the residual liquid or sufficiently displace it as necessary. Also, when reinstalling the equipment or restarting it after replacement, confirm the safety of the product before checking that it operates normally.

3. Use appropriate protective equipment.

When touching the process pump for maintenance, wear protective equipment such as gloves which are compatible with the fluid used. There is a risk of chemical burns.

4. Do not disassemble the product, as disassembly will invalidate the product's warranty.

5. Drain discharge

Operating the system with drain accumulated in the equipment or piping may cause a malfunction of the equipment, splash over into the downstream side, or unexpected accident. Periodically discharge drain from components including the air filter.

6. Caution when transferring a high-temperature fluid

The product itself will become hot due to the high-temperature fluid. Since touching the product directly may cause burns, allow sufficient time for the product to cool down when transferring a high-temperature fluid. The measurement of the product temperature is recommended to confirm the safety of the system before performing work.

7. Caution when a temperature history cycle is applied.

When a temperature history (heat cycle) is applied, the resin thread may extend. Additionally tighten with the specified torque (M3: 0.11 to 0.12 N·m) to prevent liquid leakage.

Caution

1. Caution when transferring a highly penetrating liquid

When transferring a liquid that is highly penetrating through fluoropolymer, components of the transferred liquid may enter the openings inside the equipment. Also, they may become attached to the external surface of the equipment. In this case, take the same measures as handling the transferred liquid.

2. Service life of diaphragm and maintenance of consumable items

- If the operating cycle of the process pump exceeds the service life of diaphragm, the diaphragm may be damaged due to deterioration. If it is damaged, the fluid will leak from the pilot air exhaust port and the air will blow out into the liquid circuit. Consider the pump operation (breathing, decline of discharge pressure, etc.) and the reference service life of diaphragm, and replace with new process pump or conduct necessary maintenance as early as possible.
- Items such as check valves, switching valves and pilot valves may experience a malfunction earlier than the diaphragm depending on the operating conditions. Replacement of the whole product or maintenance should be performed as soon as possible.
- When conducting maintenance, obtain the necessary parts indicated in the maintenance parts list (P.18), and perform work according to the maintenance and operation manuals.

3. Please understand the following concerning the inability to repair the product.

- To enable the process pump to be used with various fluids, please note that from the aspects of ensuring worker safety and also the facilities, SMC is unable to carry out repair.

[Calculation of reference service life (days) of diaphragm]

$$\text{Reference service life (days)} = \frac{A \text{ (Amount of discharge per cycle)} \times B \text{ (Reference number of cycles in service life)}}{\text{Flow rate (L/min)} \times \text{Operating time per day (hour)} \times 60 \text{ (min)}}$$

Model	Operating Method	Diaphragm material	Amount of discharge per cycle A	Reference number of cycles in service life B	Volume inside pump (wetted part)
PAF3410	Automatically operated	PTFE	Approx. 0.054L	50 million cycles	Approx. 105mL

7. Lubrication

Caution

1. Do not lubricate the the PAF series.

8. Caution on Handling

Warning

1. Test before using with the actual equipment.

Test the pump before using it with the actual equipment. Even if there is no problem in a short-term test, the liquid may penetrate through the fluoropolymer diaphragm causing a malfunction in the pump air circuit.

2. Storage

In the case of long-term storage after use, first thoroughly remove the liquid, and clean and dry the inside to prevent deterioration of the pump materials.

3. After a long period of non-use, perform a trial run prior to operation.

4. Ensure that the bolts are not loose before operating the process pump.

5. Adjustment of the discharge amount

Connect the discharge volume adjustment valve (throttle) to the FLUID OUT port of the process pump. Adjust the volume by adjusting the opening of the valve.

6. When the discharge volume is large (flow velocity is high) depending on the fluid type and operating conditions, cavitation may lead to poor operation or failure. Increase supply air pressure or decrease the discharge volume with a throttle so that cavitation is not generated.

7. Operating environment

When dangerous fluid is used, take measures to isolate humans from the pump. External leakage of pumping fluid could cause serious injury.

8. Countermeasures against liquid leakage

There are some cases where the operating fluid will leak outside the pump, for example when the diaphragm reaches the end of the life. Measures should be taken to avoid leakage, such as installing a drain pan, so that people and equipment will not be adversely affected.

9. Caution for piping of the tube

Support the piping according to JIS B 8370 when piping the tube. Arrange the piping so that tension is not applied to the tube.

9. Return of Product

Warning

If the product to be returned is contaminated or is possibly contaminated with substances that are harmful to humans, for safety reasons, please contact SMC beforehand and then employ a specialist cleaning company to decontaminate the product. After the decontamination prescribed above has been carried out, submit a Product Return Request Sheet or the Detoxification/Decontamination Certificate to SMC and await SMC's approval and further instructions before attempting to return the item.

Please refer to the International Chemical Safety Cards (ICSC) for a list of harmful substances.

Applicable Fluids

Material and Fluid Compatibility Check List for Process Pumps

- The data below is prepared based on data provided by the material manufacturers.
- SMC assumes no responsibility for the accuracy of the data or for any damages arising from the data.
- The material and fluid compatibility check list provides reference values as a guide only; therefore SMC does not guarantee the application to our product.

Caution

- Select the wetted parts materials according to the transfer liquid you use to determine the model.
 - For the diaphragm material, PTFE is suitable for non-permeating liquids.
 - Use fluids that will not corrode the wetted parts materials.
- These products are not suitable for medical or food use.
- The applicability may vary depending on additives. Take note also of additives.
- The applicability may vary depending on impurities. Take note also of impurities.
- Examples of transfer liquids are shown below. Since the applicability may vary depending on your operating conditions, be sure to check it by means of experimentation.
- Compatibility is indicated for fluid temperatures specified for the respective products (90°C or less).

Table symbols ○: Can be used. ×: Cannot be used. —: Can be used under certain conditions.

Model		PAF3410
Body material		New PFA
Diaphragm material		PTFE
Chemical	Acetone	○ ^{Note 1, 2)}
	Ammonium hydroxide	○ ^{Note 2)}
	Isobutyl alcohol	○ ^{Note 1, 2)}
	Isopropyl alcohol	○ ^{Note 1, 2)}
	Hydrochloric acid	○ ^{Note 2)}
	Ozone water	○
	Hydrogen peroxide Concentration 5% or less, 50° C or less	○
	Ethyl acetate	○ ^{Note 1, 2)}
	Butyl acetate	○ ^{Note 1, 2)}
	Nitric acid (except fuming nitric acid) Concentration 10% or less	○ ^{Note 2)}
	Pure water	○
	Sodium hydroxide Concentration 50% or less	○
	Super pure water	○
	Toluene	○ ^{Note 1, 2)}
	Hydrofluoric acid	○ ^{Note 2)}
	Sulfuric acid (except fuming sulfuric acid)	○ ^{Note 2)}
Phosphoric acid Concentration 80% or less	○	

Note 1) Static electricity may be generated. Take measures to prevent static electricity.

Note 2) These may be penetrated by fluids, and the penetrating fluids may affect parts of other materials.

Caution

Caution for transferring highly penetrating liquids

Do not use liquids which are highly penetrating to fluorine resin. This may cause internal damage to the process pump or liquid leakage.

Specifications

Model		PAF3410-□03	PAF3410-P13□	PAF3410S-□S□□
Actuation		Automatically operated		
Port size	Main fluid: Suction/Discharge port	Rc, NPT, G 3/8" Female thread	1/2" Tube extension,	With nut (size 4, 5)
	Pilot air: Supply/Exhaust port	Rc, NPT, G 1/4" Female thread		
Material	Body wetted areas	New PFA		
	Diaphragm	PTFE		
	Check valve	PTFE, PFA		
Fluid		Refer to the applicable fluids on page 14.		
Discharge rate		1 to 20 L/min		
Average discharge pressure		0 to 0.4 MPa		
Pilot air pressure		0.2 to 0.5 MPa (for 0 to 60°C)		
Air consumption		230 L/min(ANR) or less		
Suction lifting range	Dry	Up to 1 m (when the pump is dry)		
	Wet	Up to 4 m (when the pump is primed)		
Noise		80 dB (A) or less (Option: with silencer, AN20)		
Withstand pressure		0.75 MPa		
Diaphragm life*		50 million times		
Fluid temperature		0 to 90°C (No freezing)		
Ambient temperature		0 to 70°C (No freezing)		
Maximum viscosity		1000 mPa·s		
Weight		1.6 kg		
Mounting orientation		Horizontal (mounting on the bottom surface)		
Packaging		Clean double packaging		

* These are reference values for room temperature and fresh water. These are not guaranteed. For details, refer to page 12.

Tube Size Applicable for Nut Size

(Tube size can be altered, using a reducer even within the same nut size.)

Size	Applicable tubing size
4	10 x 8, 12 x 10, 3/8" x 1/4", 1/2" x 3/8"
5	12 x 10, 19 x 16, 1/2" x 3/8", 3/4" x 5/8"

Performance Curve

Flow Rate Characteristics

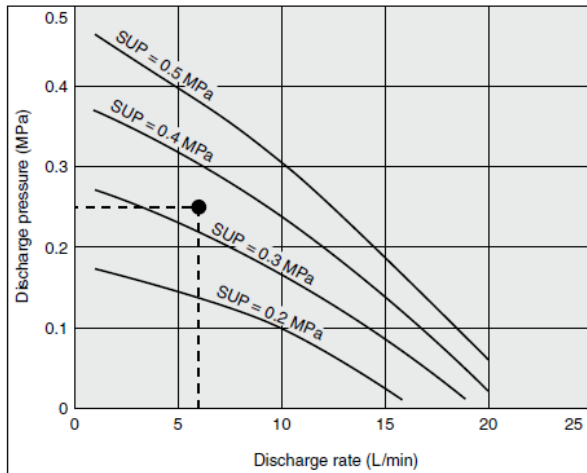

Air Consumption

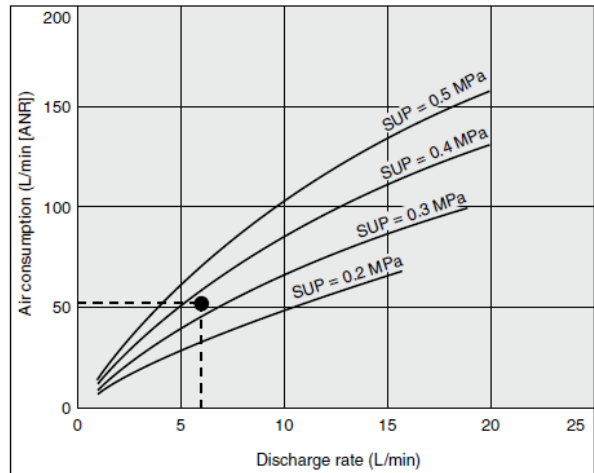

Selection from Flow Rate Characteristic Graph

Required specifications example:

Find the pilot air pressure and pilot air consumption for a discharge rate of 6 L/min and discharge pressure of 0.25 MPa. <The transfer fluid is fresh water (viscosity 1 mPa·s, specific gravity 1.0).>

* If the total lifting height is required instead of the discharge pressure, discharge pressure of 0.1 MPa corresponds to a total lift of 10 m.

Selection procedures:

1. First mark the intersection point for a discharge rate of 6 L/min and discharge pressure of 0.25 MPa.
2. Find the pilot air pressure for the marked point. In this case, the point is between the discharge curves for SUP = 0.3 MPa and SUP = 0.4 MPa, and based on the proportional relationship to these lines, the pilot air pressure for this point is approximately 0.35 MPa.
3. Next find the air consumption rate. Trace the discharge rate, 6 L/min, up to the point between the discharge curves for SUP = 0.3 MPa and 0.4 MPa, then trace to the Y-axis, finding the air consumption to be around 55 L/min (ANR).

Caution

1. These flow rate characteristics are for fresh water (viscosity 1 mPa·s, specific gravity 1.0).
2. The discharge rate differs greatly depending on properties (viscosity, specific gravity) of the fluid being transferred and operating conditions (lifting range, transfer distance), etc.
3. Use 0.75 kW per 100 L/min of air consumption as a guide for the relationship of the air consumption to the compressor.

Viscosity Characteristics

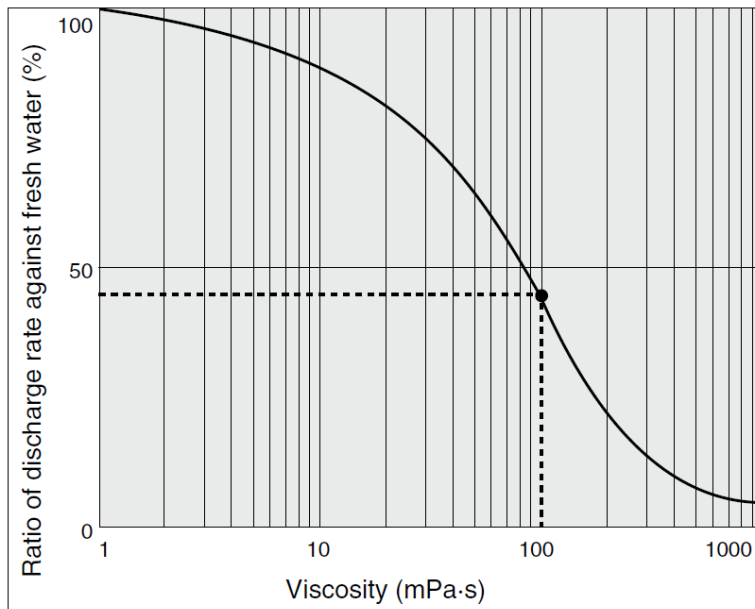

Selection from Viscosity Characteristic Graph

Required specifications example:

Find the pilot air pressure and pilot air consumption for a discharge rate of 2.7 L/min, discharge pressure of 0.25 MPa, and a viscosity of 100 mPa·s.

Selection procedures:

1. First find the ratio of the discharge rate for fresh water when viscosity is 100 mPa·s from the graph below. It is determined to be 45%.
2. Next, in the required specification example, the viscosity is 100 mPa·s and the discharge rate is 2.7 L/min. Since this is equivalent to 45% of the discharge rate for fresh water, $2.7 \text{ L/min} \div 0.45 = 6 \text{ L/min}$, indicating that a discharge rate of 6 L/min is required for fresh water.
3. Finally, find the pilot air pressure and pilot air consumption based on selection from the flow characteristic graphs.

Caution

Viscosities up to 1000 mPa·s can be used.

The following equation shows the relationship between the kinematic viscosity and the dynamic viscosity.

$$\text{Kinematic viscosity } \nu \text{ [m}^2\text{/s]} = \frac{\text{Viscosity } \mu \text{ [Pa}\cdot\text{s}]}{\text{Density } \rho \text{ [kg/m}^3\text{]}}$$

The commonly used unit system is

$$\text{Kinematic viscosity } \nu \text{ [cSt]} = \frac{\text{Viscosity } \mu \text{ [mPa}\cdot\text{s}]}{\text{Density } \rho \text{ [g/cm}^3\text{]}}$$

In addition, 1 [mPa·s] = 1 [cP].

Maintenance Parts



- Basically, it is not recommended to disassemble the process pump. However, if this is necessary, be sure to follow the instructions in the maintenance procedure.
- When carrying out this work, wear appropriate protective equipment.

Description	PAF3410
Diaphragm kit	KT-PAF3-31
Check valve kit	KT-PAF3-36
Switching valve kit	KT-PAF3-37□ ^{Note)}
Pilot valve kit	KT-PAF3-38
Manual cap assembly kit	KT-PAF3-40
Leakage sensor	KT-PAF3-47

* The maintenance procedure is to be distributed individually. Please contact your SMC sales representative for details.

Note) One of Nil, N, F or T is entered as a thread symbol.

Dimensions

Female thread: PAF3410-□03

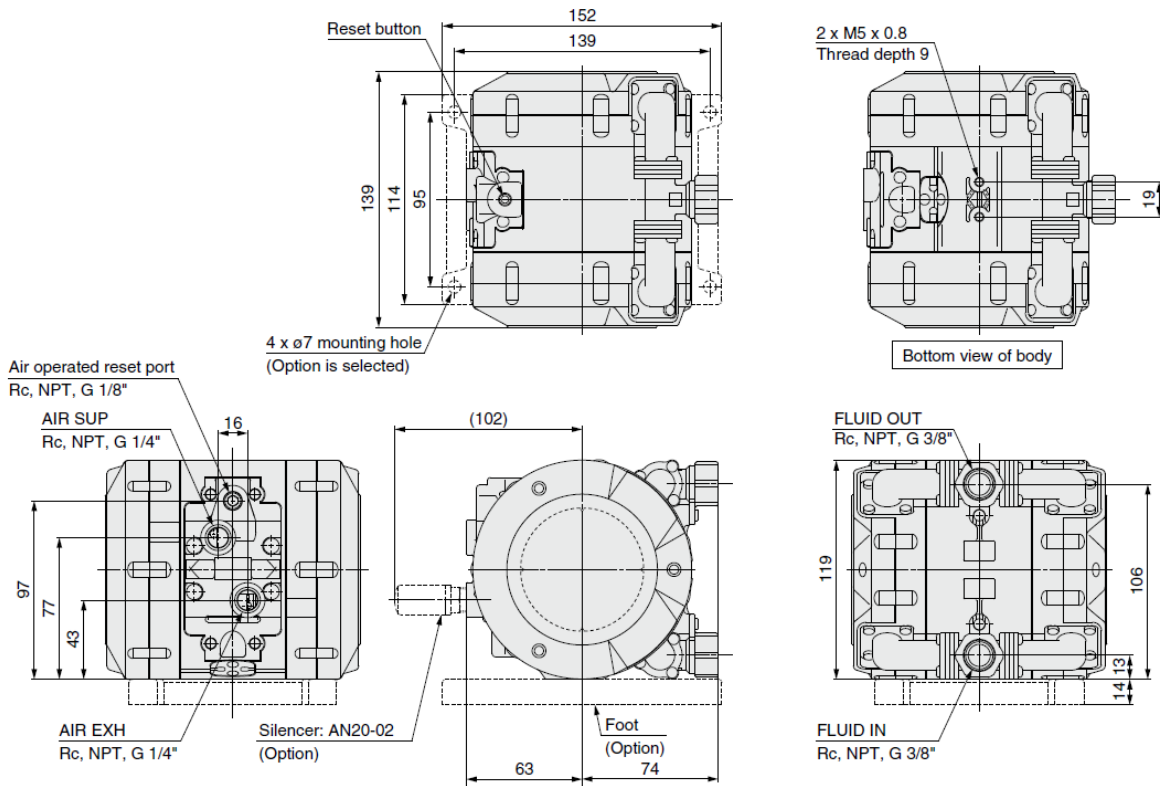

Tube extension: PAF3410-P13□

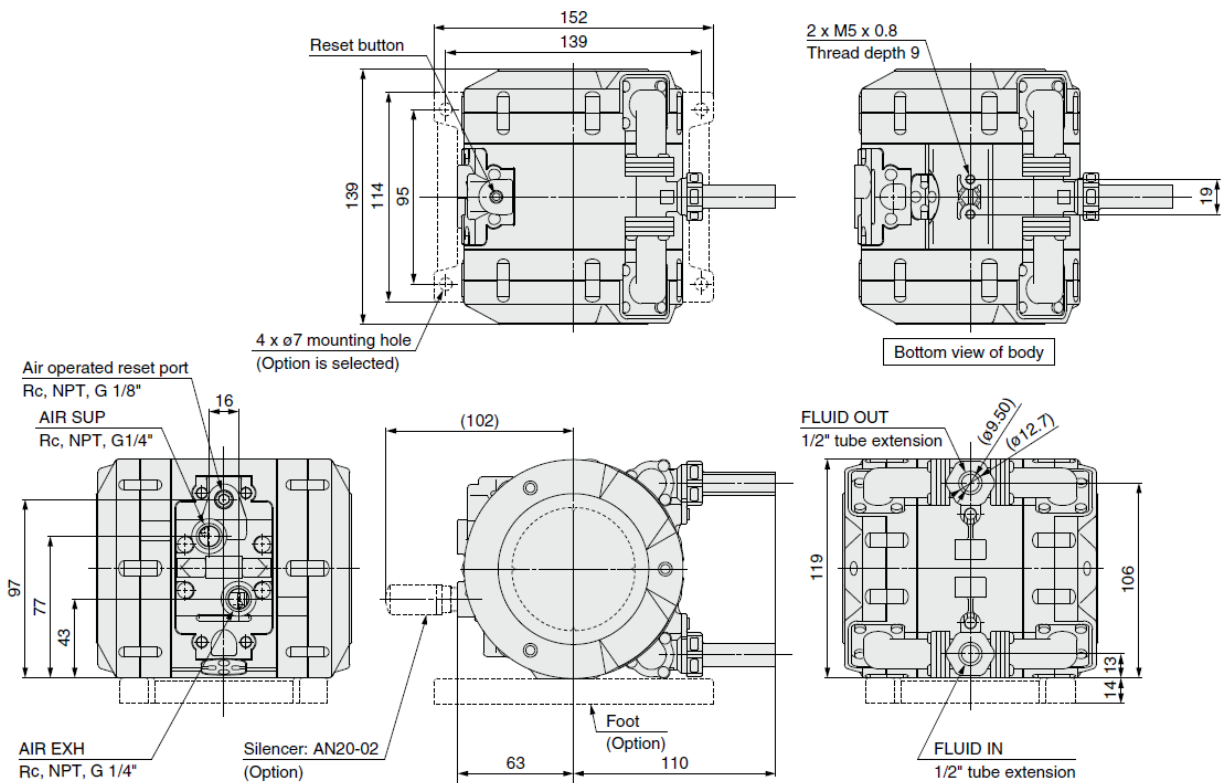

With nut (with LQ1 fittings): PAF3410S-1S13□
 PAF3410S-1S19□

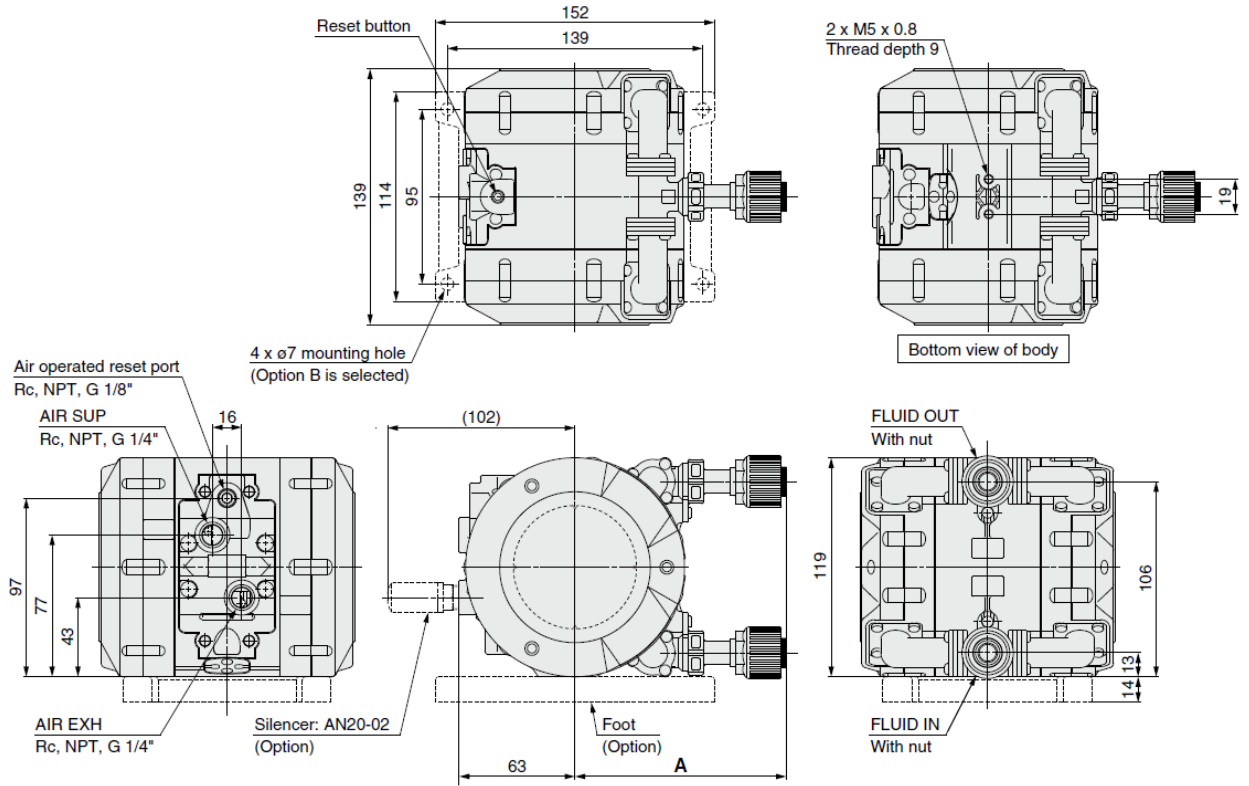

Tube Size Applicable for Nut Size

(Tube size can be altered, using a reducer even within the same nut size.)

Model	A (mm)
PAF3410S-1S13□	115
PAF3410S-1S19□	118

Size	Applicable tubing size
4	10 x 8, 12 x 10, 3/8" x 1/4", 1/2" x 3/8"
5	12 x 10, 19 x 16, 1/2" x 3/8", 3/4" x 5/8"

With nut (with LQ3 fittings): PAF3410S-3S13□

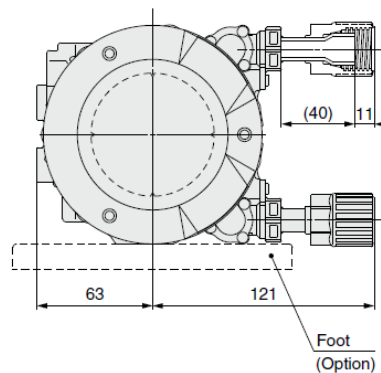

Sensor mounting (leakage sensor)

Series PAF can have a sensor for detecting diaphragm breakage. If fluid leaks in the pump through the diaphragm, this sensor responded it, and detects diaphragm breakage.

<Mounting>

1. Remove the round head Philips screws below the AIR EXH port of the pump. Then, remove the leakage sensor cover, plug, and O-ring (Fig. 1). The O-ring, leakage sensor cover, and round head Philips screws are used again later. Do not throw them away.
2. Mount the O-ring again to the part from which it is removed, and insert two leakage sensors there. Put the leakage sensor cover back to the part with the round head Philips screws (tightening torque: **0.125N·m**) (Fig. 2).
3. Insert optical fibers to the amplifier, and set the amplifier to "Percent tuning". At this time, the ratio at the threshold level is set to **20 to 25%** ^{Note 1)}.

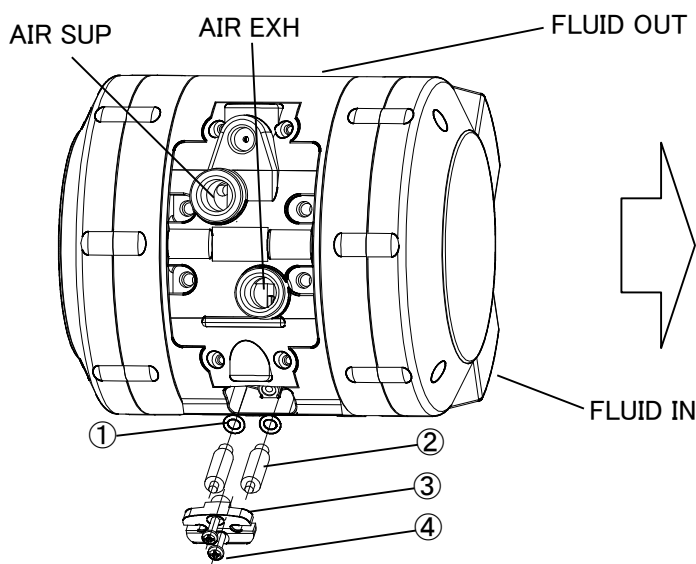

Fig. 1

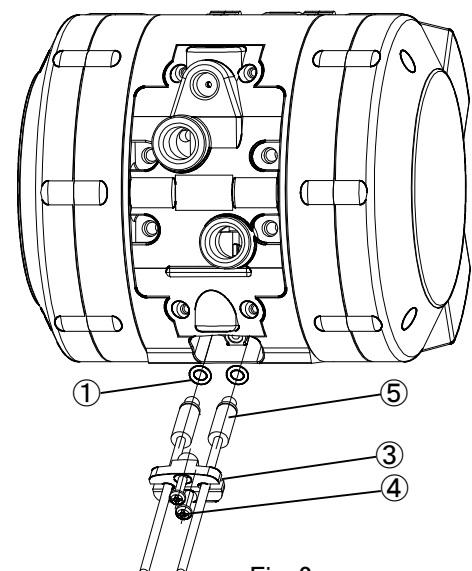

Fig. 2

Name of components

①	O-ring	2pcs
②	Plug	2pcs
③	Leakage sensor cover	1pcs
④	Round head Philips screw	2pcs
⑤	Leakage sensor ^{Note 2)}	2pcs

⚠ Caution

Tighten two round head philips screws (4) with torque **0.125N·m**.

Note1) This value is a reference value. If the output of the sensor cannot be confirmed, adjust the threshold level of the amplifier accordingly.

Note2) Two sets of fluid-leakage sensor "KT-PAF3-47" are required for one pump.

Also, one piece of amp "HPX-EG00-1S-L02" manufactured by Azbil Corporation is required for one sensor to detect the fluid leakage (two amps are required in total).

Troubleshooting

If any abnormality is found, perform checks according to the following list

Warning

- Discharge dangerous fluid from the pump.
- Do not return the pump with dangerous fluid left in it. If the product is to be returned, please refer to the 9. Return of Products on page 13.

Phenomenon		Possible cause	Remedy
Supply of air can't move the pump.		<ul style="list-style-type: none"> - Internal air piping is clogged with dust. - Suction side (FLUID IN) or discharge side (FLUID OUT) is closed or has large resistance. - Defect inside the body. - Insufficient supplied air pressure. - Intrusion of foreign materials into pump chamber. - Damaged diaphragm. 	<ul style="list-style-type: none"> - Cleaning or replacement of pilot air switching part. - Review of piping at suction or discharge side and removal of restrictor. - Replacement of pump. - Supply of air at adequate pressure. - Cleaning. - Replacement of pump.
The pump starts, but doesn't discharge.	The pump doesn't suck.	<ul style="list-style-type: none"> - Check valve is clogged. - Check valve is damaged or worn. - The filter at suction side (FLUID IN) is clogged. - Excessive required suction head. - Incorrect mounting direction. - The diaphragm is damaged or comes off. - Sealing failure of fitting at suction side (FLUID IN). - Excessive viscosity of transported fluid. - Incorrect insertion of check valve. 	<ul style="list-style-type: none"> - Cleaning. - Replacement of pump. - Cleaning of filter. - Reduction to suction head covered by the pump. - Remounting in normal direction. - Replacement of pump. - Secure mounting of seal. - Use of fluid with lower viscosity. - Remounting in correct direction.
	The pump sucks, but doesn't discharge	<ul style="list-style-type: none"> - Check valve or fitting at Discharge side (FLUID OUT) is clogged. 	<ul style="list-style-type: none"> - Cleaning.

Phenomenon	Possible cause	Remedy
The discharge rate is insufficient.	<ul style="list-style-type: none"> - Check valve at suction side (FLUID IN) or discharge side (FLUID OUT) is clogged. - Excessive viscosity of Transported fluid. - Excessive required suction or discharge pressure. - The filter of suction side (FLUID IN) is clogged. - The filter of discharge side (FLUID OUT) is clogged. - Insufficient air supply. - Too small port size of Transported fluid piping. - Application of back pressure from discharge side (FLUID OUT). 	<ul style="list-style-type: none"> - Cleaning. - Non-conformance. - Reduction of required head. - Cleaning or replacement. - Cleaning or replacement. - Supply of air at adequate pressure. - Increase of air supply. - Removal of back pressure or increase of supplied air pressure.
A lot of air bubble come out from discharge side (FLUID OUT).	<ul style="list-style-type: none"> - Air is sucked by suction side (FLUID IN). - Sealing failure of fitting at suction side (FLUID IN). - Damaged diaphragm. - Looseness of diaphragm fixing bolt. 	<ul style="list-style-type: none"> - Prevention of suction. - Secure mounting of seal. - Replacement of pump. - Retightening.
Transferred fluid is flowed out from exhaust port. (AIR EXH)	<ul style="list-style-type: none"> - Damaged diaphragm 	<ul style="list-style-type: none"> - Replacement of pump.
Transported fluid or air leaks from jointed part to outside.	<ul style="list-style-type: none"> - The diaphragm is damage or comes off. - Looseness of bolts which fix the parts at each port (port, elbow fixing flange, port fixing flange, air port cover). 	<ul style="list-style-type: none"> - Replacement of pump. - Retightening.

Revision history

2004-03-11	Initial release
2005-11-11	Rev. A
2006-05-24	Rev. B
2007-05-17	Rev. C
2020-08-18	Rev. D
2024-10-30	Rev. E

SMC Corporation

Tel: + 81 3 5207 8249 Fax: +81 3 5298 5362
URL <https://www.smcworld.com>

Note: Specifications are subject to change without prior notice and any obligation on the part of the manufacturer.
© SMC Corporation All Rights Reserved