



Operation Manual

PRODUCT NAME

Mechanically jointed rodless cylinder
Basic type
With Slide bearing guide type
With cam follower guide type
With linear guide type
With High rigidity/ Linear guide type
With Protective Cover type

MODEL / Series / Product Number

MY1B/M/C/H/HT Series
MY1B/H*-*Z Series
MY1MW/CW Series

SMC Corporation

Contents

Safety Instructions -----P. 2

1. Product Specifications

1.1 Specifications -----P. 4

1.2 End-lock type -----P. 6

2. Operation and Mounting

2.1 Air Supply -----P. 6

2.2 Operating Environment -----P. 7

2.3 Design -----P. 8

2.4 Mounting and Installation -----P. 9

2.5 Piping -----P. 13

2.6 Speed Control -----P. 15

2.7 Shock Absorbing Mechanism -----P. 15

2.8 Directional Control -----P. 18

2.9 Mounting of Auto Switch -----P. 18

3. Maintenance and Inspection

3.1 Inspection -----P. 20

3.2 Maintenance -----P. 20

3.3 Replacement Parts -----P. 20

4. Troubleshooting

-----P. 20



Safety Instructions

These safety instructions are intended to prevent hazardous situations and/or equipment damage. These instructions indicate the level of potential hazard with the labels of “**Caution**,” “**Warning**” or “**Danger**.” They are all important notes for safety and must be followed in addition to International Standards (ISO/IEC)^{*1)}, and other safety regulations.

*1) ISO 4414: Pneumatic fluid power - General rules and safety requirements for systems and their components
ISO 4413: Hydraulic fluid power - General rules and safety requirements for systems and their components
IEC 60204-1: Safety of machinery - Electrical equipment of machines - Part 1: General requirements
ISO 10218-1: Robots and robotic devices - Safety requirements for industrial robots - Part 1: Robots
etc.



Danger

Danger indicates a hazard with a high level of risk which, if not avoided, will result in death or serious injury.



Warning

Warning indicates a hazard with a medium level of risk which, if not avoided, could result in death or serious injury.



Caution

Caution indicates a hazard with a low level of risk which, if not avoided, could result in minor or moderate injury.

Warning

1. The compatibility of the product is the responsibility of the person who designs the equipment or decides its specifications.

Since the product specified here is used under various operating conditions, its compatibility with specific equipment must be decided by the person who designs the equipment or decides its specifications based on necessary analysis and test results. The expected performance and safety assurance of the equipment will be the responsibility of the person who has determined its compatibility with the product. This person should also continuously review all specifications of the product referring to its latest catalog information, with a view to giving due consideration to any possibility of equipment failure when configuring the equipment.

2. Only personnel with appropriate training should operate machinery and equipment.

The product specified here may become unsafe if handled incorrectly. The assembly, operation and maintenance of machines or equipment including our products must be performed by an operator who is appropriately trained and experienced.

3. Do not service or attempt to remove product and machinery/equipment until safety is confirmed.

1. The inspection and maintenance of machinery/equipment should only be performed after measures to prevent falling or runaway of the driven objects have been confirmed.
2. When the product is to be removed, confirm that the safety measures as mentioned above are implemented and the power from any appropriate source is cut, and read and understand the specific product precautions of all relevant products carefully.
3. Before machinery/equipment is restarted, take measures to prevent unexpected operation and malfunction.

4. Our products cannot be used beyond their specifications. Our products are not developed, designed, and manufactured to be used under the following conditions or environments. Use under such conditions or environments is not covered.

1. Conditions and environments outside of the given specifications, or use outdoors or in a place exposed to direct sunlight.
2. Use for nuclear power, railways, aviation, space equipment, ships, vehicles, military application, equipment affecting human life, body, and property, fuel equipment, entertainment equipment, emergency shut-off circuits, press clutches, brake circuits, safety equipment, etc., and use for applications that do not conform to standard specifications such as catalogs and operation manuals.
3. Use for interlock circuits, except for use with double interlock such as installing a mechanical protection function in case of failure. Please periodically inspect the product to confirm that the product is operating properly.



Safety Instructions

Caution

We develop, design, and manufacture our products to be used for automatic control equipment, and provide them for peaceful use in manufacturing industries.

Use in non-manufacturing industries is not covered.

Products we manufacture and sell cannot be used for the purpose of transactions or certification specified in the Measurement Act.

The new Measurement Act prohibits use of any unit other than SI units in Japan.

Limited warranty and Disclaimer/Compliance Requirements

The product used is subject to the following “Limited warranty and Disclaimer” and “Compliance Requirements”. Read and accept them before using the product.

Limited warranty and Disclaimer

1. The warranty period of the product is 1 year in service or 1.5 years after the product is delivered, whichever is first.*2)
Also, the product may have specified durability, running distance or replacement parts. Please consult your nearest sales branch.
2. For any failure or damage reported within the warranty period which is clearly our responsibility, a replacement product or necessary parts will be provided.
This limited warranty applies only to our product independently, and not to any other damage incurred due to the failure of the product.
3. Prior to using SMC products, please read and understand the warranty terms and disclaimers noted in the specified catalog for the particular products.

***2) Vacuum pads are excluded from this 1 year warranty.**

A vacuum pad is a consumable part, so it is warranted for a year after it is delivered.

Also, even within the warranty period, the wear of a product due to the use of the vacuum pad or failure due to the deterioration of rubber material are not covered by the limited warranty

Compliance Requirements

1. The use of SMC products with production equipment for the manufacture of weapons of mass destruction (WMD) or any other weapon is strictly prohibited.
2. The exports of SMC products or technology from one country to another are governed by the relevant security laws and regulations of the countries involved in the transaction. Prior to the shipment of a SMC product to another country, assure that all local rules governing that export are known and followed.

1. Product Specifications

1-1 Specifications

1-1-1. MY1B/C/H/HT/CW series

	ø10	ø16	ø20~ø100
Fluid	Air		
Proof pressure	1.2 MPa		
Max. operating pressure	0.8 MPa		
Min. operating pressure	0.2MPa	0.1 MPa	
Ambient and fluid temperature	+5 to +60 °C (No freezing)		
Lubrication	Not required (non-lube)		
Stroke length tolerance	1000 or less	$+1.8_0$ mm	2700 or less $+1.8_0$ mm
	1001 to max stroke	$+2.8_0$ mm	2701 to max stroke $+2.8_0$ mm
Cushion	Rubber bumper Shock absorber	Air cushion, Shock absorber	
Piston speed	100 to 1000 mm/s	100 to 1500 mm/s	

1-1-2. MY1M/MW series

	ø16	ø20~ø63
Fluid	Air	
Proof pressure	1.2 MPa	
Max. operating pressure	0.8 MPa	
Min. operating pressure	0.15MPa	
Ambient and fluid temperature	+5 to +60 °C (No freezing)	
Lubrication	Not required (non-lube)	
Stroke length tolerance	1000 or less	$+1.8_0$ mm
	1001 to max stroke	$+2.8_0$ mm
Cushion	Air cushion, Shock absorber	
Piston speed	100 to 1500 mm/s	

Warning

1. Confirm the specifications.

The product is designed for use only in industrial compressed air systems. Do not operate at pressures or temperatures etc., beyond the range of specifications, as this can cause damage or malfunction. (Refer to the specifications.)

SMC does not guarantee against any damage if the product is used outside of the specification range.

2. Do not operate the product with the guide load factor that is more than the allowable value.

Mechanical joint type rodless cylinder has a guiding function with the cylinder. It is possible to mount a load directly to the cylinder. Use caution not to allow the guide load factor to exceed the allowable value.

Operation with the load out of the allowable range may cause damage to the cylinder or an operation failure at an earlier stage.

Refer to the catalogue for the calculation method for the allowable guide load.

3. Confirm the applicable range of the specifications.

The product specifications are applicable to all the standard strokes including an intermediate stroke and long stroke.

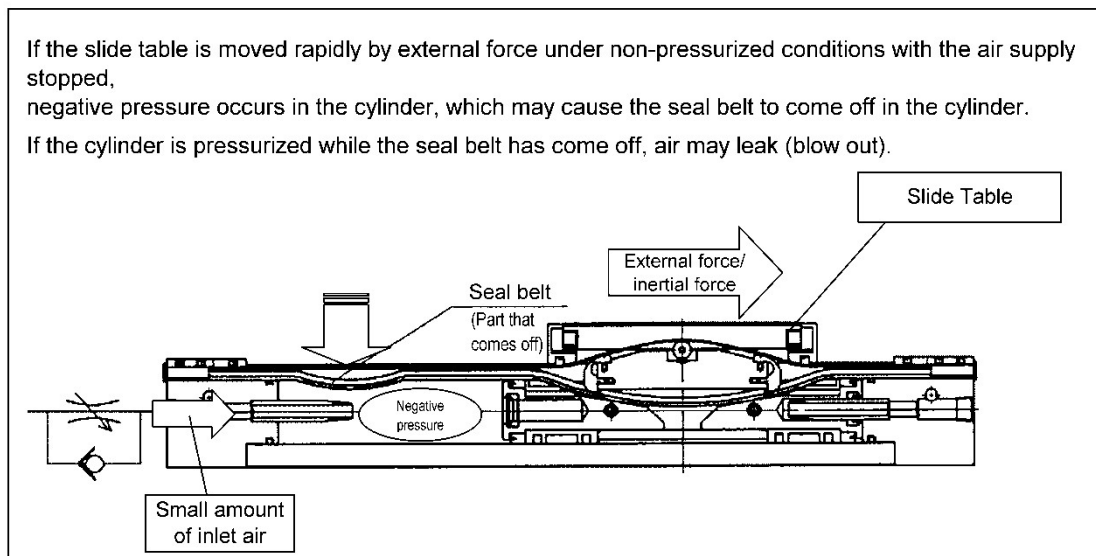
For custom-made products/special products other than shown above may not have specifications that are different from the specifications described in this manual.

Caution

1. Air leakage due to removal of the seal belt

Mechanical joint type rodless cylinders may have a temporary external air leakage in some operating conditions due to the product construction when negative pressure is generated inside the cylinder with external force, inertial force, or etc. When this happens, refer to "How to put back the seal belt when it comes off" shown below and carefully return the seal belt to the position not to damage the seal belt. Damage to the seal belt may cause permanent air leakage.

How to put back the seal belt when it comes off



	Procedure	Cautions
①	Shut off the air supply and keep it unpressurized	Do not leave any residual pressure.
②	Remove the piping connected to the cylinder, and release it to atmosphere.	Remove anything that will act as a restrictor, such as a speed controller, wherever possible.
③	Make sure the cylinder can perform a total stroke	If a stroke adjustment unit is mounted, remove it or adjust the stroke to perform a total stroke. If an external stopper is mounted, remove it or take measures so it will not stop the cylinder from performing the total stroke.
④	Move the slide table slowly by hand to make a full return stroke.	If the slide table gets stuck (does not move smoothly) while it is being moved, do not force it. Pull it back slightly and then move it forward again. (If the cylinder is mounted vertically, remove work pieces and move the slide table by hand, the same as it would in operation)
⑤	Connect the piping to the cylinder and supply air gradually.	If there are no remarkable amount of air leaks, this completes the procedure.

1-2. End-lock type (Cylinder with end lock)

	ø16	ø20	ø25	ø32	ø40
Lock position	Single side (selectable), both sides				
Holding force (max.)N	110	170	270	450	700
Stroke fine adjustment range (mm)	0 to -5.6	0 to -6	0 to -11.5	0 to -12	0 to -16
Backlash	1mm or less				
Manual release	Possible (Non-locking type)				

Warning

- To disengage the lock, make sure to supply air pressure to the port on the side without a lock mechanism, thus preventing the load from being applied to the lock mechanism.**

If the lock is disengaged when the port on the side that does not contain a lock mechanism is in the exhausted state and the load is being applied to the lock mechanism, undue force will be applied to the lock mechanism, and it may damage the lock mechanism. This could also result in sudden movement of the slide table which could be dangerous. (Use the Recommended Pneumatic Circuit)

Caution

- Use Recommended Air Pressure Circuit.**

This is necessary for proper operation and release of the lock. (Fig. 1)

- Do not use 3 position solenoid valves.**

If the port on the lock mechanism side is pressurized, the cylinder cannot be locked.

- Release the lock when mounting or adjusting the cylinder.**

If mounting or other work is performed when the cylinder is locked, the lock unit may be damaged.

- Operate with a load ratio of 50% of theoretical output or less.**

If the load ratio exceeds 50% of theoretical output, this may cause problems such as failure of the lock to release, or damage to the lock unit.

- Do not operate multiple cylinders in synchronization.**

Avoid applications in which two or more end lock cylinders are synchronized to move one workpiece, as one of the cylinder locks may not be able to release when required. The lock of one of the cylinder may not be able to be released.

- Use a speed controller with meter-out control.**

Lock cannot be released occasionally by meter-in control.

- Be sure to operate completely to the cylinder stroke end on the side with the lock.**

If the cylinder piston does not reach the end of the stroke, locking might not work or locking might not be released.

- Use pressure over 0.15 MPa at port with locking mechanism.**

It is necessary to unlock.

- It may take time if the exhaust speed is low.**

Locking will occur automatically if the pressure applied to the port on the lock mechanism side falls to 0.05MPa or less. In cases where the piping on the lock mechanism side is long and thin, or the speed controller is separated at some distance from the cylinder port, the exhaust speed will be reduced. Take note that some time may be required for the lock to engage. In addition, clogging of a silencer mounted on the solenoid valve exhaust port can produce the same effect.

- When the locking mechanism is full closed, do not use with then air cushion.**

The slide table may not reach full stroke. Therefore, the cylinder cannot be locked.

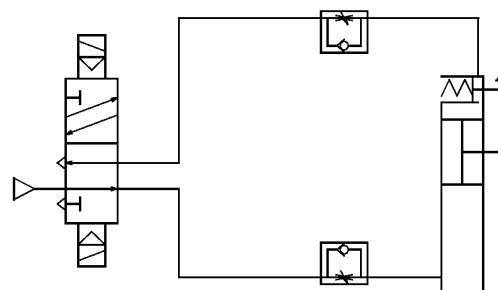


Fig. 1

2. Operation and Mounting

2-1. Air supply

The compressed air supplied to the cylinder should be filtered by SMC AF series air filter and regulated to the specified set pressure by SMC AR series regulator.

Warning

1. Use clean air.

Do not use compressed air that contains chemicals, synthetic oils including organic solvents, salts or corrosive gases etc., as this can cause damage or malfunction.

Caution

1. Install an air filter.

Install an air filter upstream near the valve. Select an air filter with a filtration size of 5 μ m or smaller.

2. Install an aftercooler, air dryer or drain catch before the filter.

Compressed air that contains excessive foreign material may cause malfunction of valves and other pneumatic equipment.

3. Discharge condensates regularly.

If condensate in the drain bowl is not emptied on a regular basis, the condensate will overflow and allow it to enter the compressed air lines. This will cause a malfunction of pneumatic equipment. If the drain bowl is difficult to check and remove, installation of a drain bowl with an auto drain option is recommended.

4. Use the product within the specified fluid and ambient temperature range.

When operating at temperatures below 5°C, moisture in the circuit may freeze and cause damage to the seals or a malfunction. Use within the specified operating temperature range.

5. Usage of ultra dry air as fluid

When low dew point air is used as the fluid, degradation of the lubrication properties inside the equipment may occur, resulting in reduced reliability (or reduced service life) of the equipment. Consider using low dew point products such as 25A-series.

6. Lubrication of non-lubricating cylinder

The product has been lubricated during manufacturing, so it does not require lubrication in service.

When refueling, please check our website for the brands of turbine oil class 1 (additive-free) and class 2 (additives) from each company.

Once lubricant is used in the system, lubrication must be continued because the original lubricant applied during manufacturing will be washed away.

For detailed information regarding the quality of the compressed air described above, refer to SMC's "Air Cleaning Systems".

2-2. Operating Environment

Warning

1. Do not use in environments where there is a danger of corrosion.

2. Do not use in direct sunlight.

3. Do not operate in a location subject to vibration or impact.

4. When using auto switches, do not operate in an environment with strong magnetic fields.

5. Grease base oil can decrease depending on external environment and operating conditions. This may reduce the lubrication performance and shorten the life of the equipment.

6. Avoid using the product in an environment that exposed to foreign matter.

If the cylinder is used in an environment where there is possible contact with cutting chips, dust (paper, yarn debris, etc.), spatter or any liquids (cutting oil, light oil, moisture, etc.), debris may enter the cylinder and cause operation failure.

When operating in such an environment is unavoidable, mount a cover to the product or mount the product on the ceiling. Note that some liquid coolant may give adverse influence to the sealing parts.

7. Even when the cylinder with cover is used, floating objects in the coolant mist may enter into the cover.

In an environment where a large amount of condensate, moisture, oil, debris, or other floating substances is present, entry into the product will occur due to a gap between the cover and cylinder tube. This will result in operation failure.

8. Avoid storing the product in high temperature and/or humid conditions.

Rust may be generated or the sealing parts may be deteriorated in such an environment.

2-3. Design

The compatibility of the product is the responsibility of the person who designs the equipment or decides its specifications.

Warning

1. There is a possibility of dangerous sudden action by cylinders if force is changed due to twisting of sliding parts of machinery.

In such cases, human injury may occur; e.g., by catching hands or feet in the machinery, or damage to the machinery itself may occur. Therefore, the machine should be designed to operate smoothly and avoid such dangers.

2. A deceleration circuit or shock absorber etc. may be required.

When a driven object moves at a high speed or the load is heavy, it may be unfeasible for only the cylinder's air cushion or shock absorber to absorb the shock. Therefore provide a speed reduction circuit to reduce the cylinders speed or install an external shock absorber to dampen the shock. If these countermeasures are taken, confirm the rigidity of the equipment carefully.

3. A protective cover is recommended to minimize the risk of personal injury.

If the driven object or moving parts of the product will pose a hazard to humans, a construction that prevents direct contact with the exposed area must be provided.

For product with stroke adjusting unit, the clearance between the slide table (slider) and the stroke adjusting unit at the stroke end is small.

When the cylinder is operating at a high speed and high frequency, the surface temperature of the cylinder tube increases, and may cause injury to personnel.

4. Be certain that the mounting fasteners will not become loose.

When the product operates with high frequency or is installed where there is a lot of vibration, ensure that all parts remain secure.

5. Design the system so external forces over the maximum specifications will not be applied.

The product can break, causing a risk of injury or damage to equipment.

6. The cylinder generates a large force. Install on a sufficiently rigid mounting base, taking this force into consideration.

There is a risk of injury to personnel or damage to equipment.

7. Consider an air pressure drop that caused by a power source related malfunction.

There is a danger of workpieces dropping if there is a decrease of thrust due to a drop in circuit pressure caused by a power source malfunction etc. Therefore, safety equipment should be installed to prevent damage to machinery and/or injury to personnel. Suspension equipment and lifting devices also require measures to prevent dropping.

8. Consider the possibility of power source related malfunctions.

For equipment that relies on power sources such as compressed air, electricity, or hydraulic pressure, adopt countermeasures to prevent the equipment from causing a hazard to humans or damage to the equipment in the event of malfunction.

9. Consider the behavior of an emergency stop.

A safety system should be devised so that if personnel engage the emergency stop, or if a safety device is tripped during a system malfunction (such as a power source malfunction), the movement of the cylinder will not cause a hazard to personnel or damage the equipment.

10. Consider the action when operation is restarted after an emergency stop or abnormal stop.

Design the machinery so that personal injury or damage to equipment will not occur upon restart of operation. Install manually controlled equipment for safety when the actuator has to be reset to the starting position.

Caution

1. Operate the product within a range such that the piston will not collide and be damaged at the stroke end.

If the piston with inertia force is stopped by colliding with the cover at the stroke end, operate the cylinder within a range that will not cause damage. Refer to the cylinder model selection table for the range that will not cause damage.

2. Mount an intermediate support to a long stroke cylinder.

For a long stroke cylinder, mount an intermediate support to prevent vibration or external force from being applied to the product or to prevent deflection of the body due to the product's own weight.

3. When using an external guide together with the cylinder, hold the load only with the external guide, and only use the cylinder as a driving source.

The longer the stroke, the greater the amount of variation in the center axis. Therefore, a method of connection which can absorb the displacement (i.e. floating mechanism) should be considered. Basic type series, MY1B, which is suitable to be used as a driving source and optional floating joint, are available. Please refer to the catalogue for details.

Using with a heavy load will result in sudden lurching which will lead to the floating joint pin breaking.

4. Avoid using cylinders for synchronized operations.

Even if multiple cylinders are initially set to the same speed, their speeds may vary due to changes in operating conditions. In such a case, an excessive moment will be applied to the slide tables and it may cause operation failure. Do not design a circuit using more than one cylinder in a synchronized operation to transfer one load.

5. Grease has been applied on the cylinder surface.

Do not wipe it off. Removing the grease may cause malfunction due to lack of lubrication.

6. The pre-applied grease may result in base oil seeping out.

The base oil of the grease in the cylinder may seep out of the tube, cover, slider or guide sliding part depending on the operating conditions (ambient temperature 40 °C or more, pressurized condition, low frequency operation).

7. Do not use the cylinder without the guide for driving a load.

The MY1HT series cylinder for driving can be detached from the guide. However, it is constructed to be used for driving the product body, it may cause failure if it is used solely with a load applied.

2-4. Mounting and Installation

2-4-1. Mounting Surface

It is recommended to mount the cylinder on a surface with a high flatness (e.g. a machined surface). If the mounting surface flatness is questionable, use shims to adjust the flatness to make it possible for the slide table to operate with the minimum operating pressure for the entire stroke.

Mounting surface of the slide table is machined with high accuracy. Flatness of the mounting surface of the mating part must be 0.03 at maximum. When the flatness cannot be obtained, use shims for adjustment of the mounting surface of the cylinder as shown above.

2-4-2. Mounting

- Two mounting methods are available for this cylinder:

Choose the mounting method according to the mounting surface and the mounting place conditions.

MY1HT series is held by T slot at the bottom.

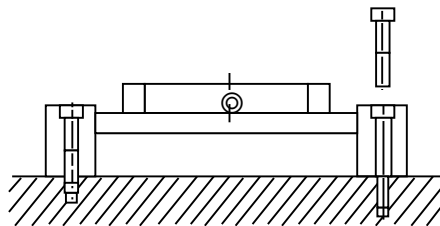


Fig. 2: Holding the product from the top
(Head cover at both ends)

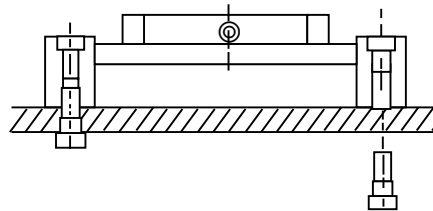


Fig. 3: Holding the product from the bottom
(Head cover, T slot only for MY1HT)

- At least 5mm of both ends of the cylinder tube have to contact with the attachment point. (See Fig. 4)

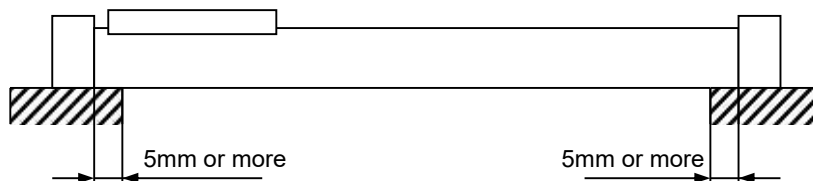


Fig. 4

- Do not mount the product with the slide table fixed as shown in Fig. 5. Excessive load will be applied to the bearing, and it may cause operation failure.
- Do not cantilever mounting as shown in Fig. 6. Deflection of the cylinder body may result in operation failure.

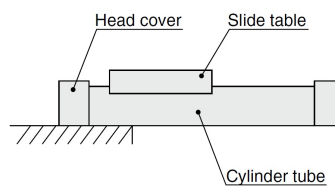
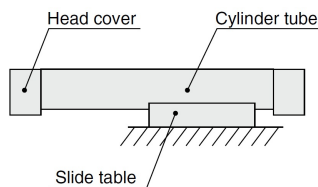


Fig. 5: Product mounting with the slide table fixed <Prohibited> Fig. 6: Cantilever mounting <Prohibited>

- The cylinder tube may deflect due to its own weight, load, or etc. When the cylinder tube is deflected, hold the cylinder at the intermediate position using the side support. Support spacing (L) shown in Fig. 7 must be the values shown in Fig. 8 or less.

Note) Using the side support for mounting a cylinder that has mounting surfaces that are not flat enough may cause failure. Adjust the mounting surface level when using the side support.

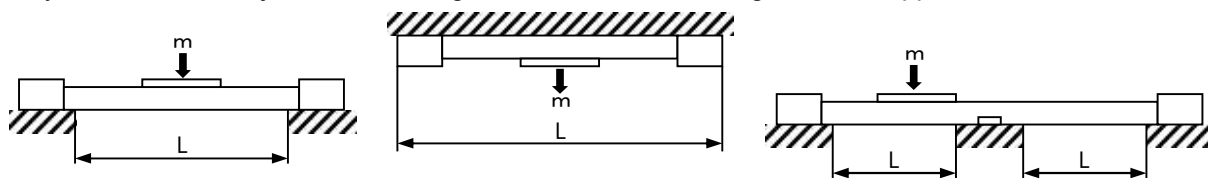
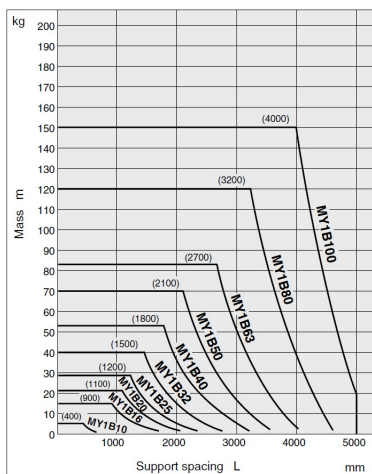
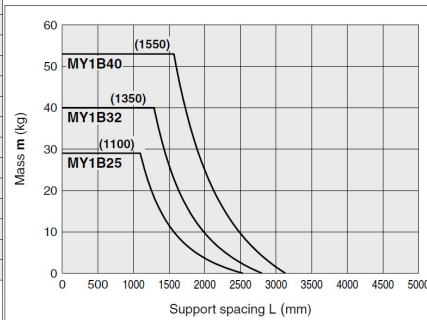


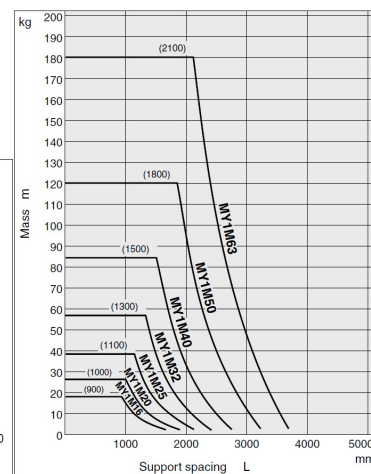
Fig. 7



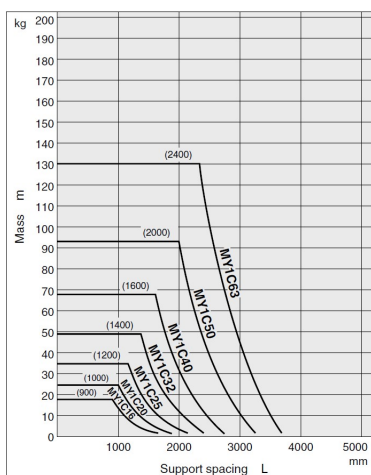
MY1B series



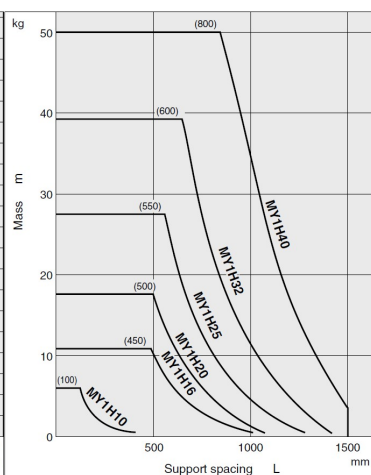
MY1B*Z series



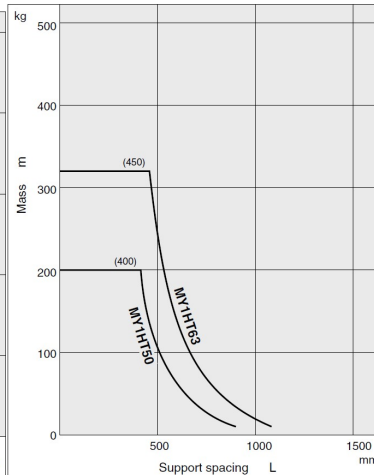
MY1M/MY1MW series



MY1C/MY1CW series



MY1H/MY1H*Z series



MY1HT series

Fig. 8

- When using the product that has a stroke that exceeds the stroke fine adjustment range, use an intermediate fixing spacer. Refer to the table below for the stroke fine adjustment range and the stroke adjustment range when using the intermediate fixing spacer.

(Intermediate fixing spacer is not available for $\phi 10$ and MY1HT series)

	0	$\sqrt{-5}$	$\sqrt{-10}$	$\sqrt{-15}$	$\sqrt{-20}$	$\sqrt{-25}$	$\sqrt{-30}$	$\sqrt{-35}$	$\sqrt{-40}$
MY1*16	0 to 5.6 Without spacer	5.6 to 11.2 Short spacer	11.2 to 16.8 Long spacer						
MY1*20	0 to 6 Without spacer	6 to 12 Short spacer	12 to 18 Long spacer						
MY1*25	0 to 11.5 Without spacer		11.5 to 23 Short spacer		23 to 34.5 Long spacer				
MY1*32	0 to 12 Without spacer		12 to 24 Short spacer		24 to 36 Long spacer				
	0	$\sqrt{-10}$	$\sqrt{-20}$	$\sqrt{-30}$	$\sqrt{-40}$	$\sqrt{-50}$	$\sqrt{-60}$	$\sqrt{-70}$	$\sqrt{-80}$
MY1*40	0 to 16 Without spacer	16 to 32 Short spacer	32 to 48 Long spacer						
MY1*50	0 to 20 Without spacer	20 to 40 Short spacer	40 to 60 Long spacer						
MY1*63	0 to 25 Without spacer		25 to 50 Short spacer		50 to 75 Long spacer				

Table 1: Stroke adjustment range (Without spacer, with short spacer, with long spacer)

Warning

1. Secure all the mounting screws firmly to mount the slide table.

If not, the slide table and/or the mounting screws may be damaged, and the workpiece may drop.

2. Carefully lift the cylinder to avoid injuries to hands and fingers.

Use crane for raising heavy cylinders with large port or long stroke. MY1HT series has mounting holes to attach eyebolt for lifting. (Eyebolt is not included.)

Caution

1. Do not apply a strong impact or excessive moment to the slide table.

The slide table is supported by a resin slide bearing or precision rolling bearing. Do not apply a strong impact or excessive moment when mounting a workpiece.

2. When connecting a load with an external guide mechanism, be sure to align carefully.

3. Do not hit or grip the cylinder tube with objects.

Scratches or dents in the external circumference of the cylinder tube may damage the bearing and/or the scraper, and it may cause operation failure.

4. Use caution not to allow foreign matter such as cutting particles to enter the cylinder from the air supply port.

Foreign matter such as cutting particles or dust entering the product during the product mounting may cause operation failure.

5. Do not change the setting of the guide adjusting part without careful consideration.

The guide has been adjusted as default. Readjustment will not be required in normal operating conditions.

6. Do not fix the stroke adjustment unit at the intermediate position.

The stroke adjustment unit may be displaced depending on the volume of the collision energy.

7. Do not use the product until you have verified that the equipment can operate properly.

After mounting or repair, connect the air and power supplies to the product and perform appropriate functional and leakage inspections to check it is mounted properly.

8. Horizontal mounting is recommended to maximize the effect of the cylinder with cover.

Horizontal mounting has less possibility of dust entry from the bottom than other mounting orientation.

9. When the cylinder with cover is mounted vertically, a stroke adjusting unit is installed, or side seal is attached, the cover needs to be removed.

See catalog for the detailed assembly procedure.

10. Release the pressure when performing manual release of the end lock.

If the pressure remains when manual release is performed, damage to the workpiece may occur due to sudden action.

11. In order to unlock the end lock, push the lock piston with a screwdriver to move the slide table.

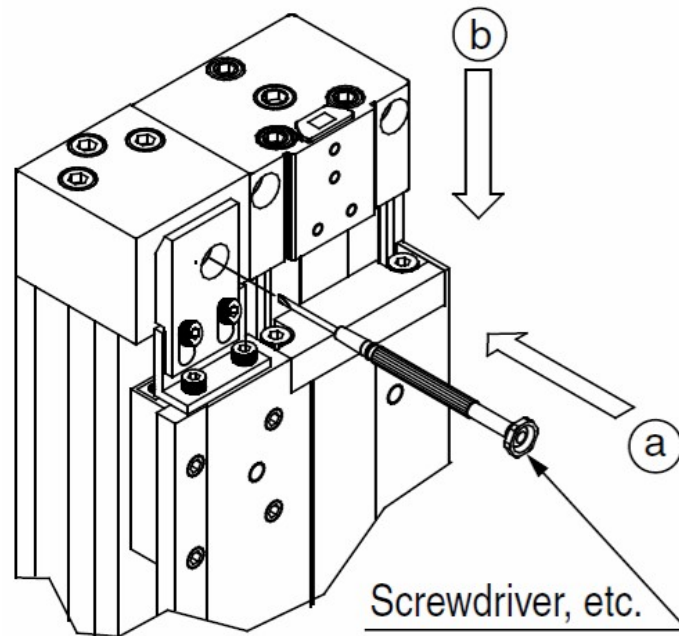


Fig. 9

2-5. Piping

Ports on the head cover for piping connection can be selected as preferred.

Refer to the port variation digram (see Fig. 10) to find the most suitable ports for piping connection.

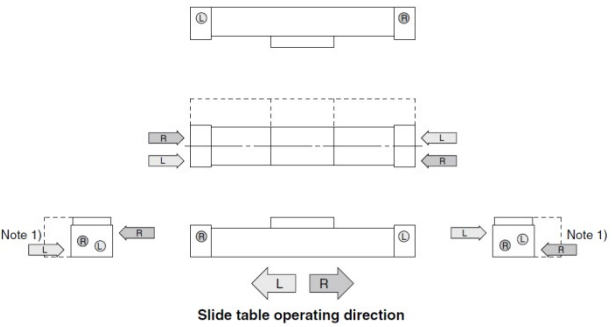
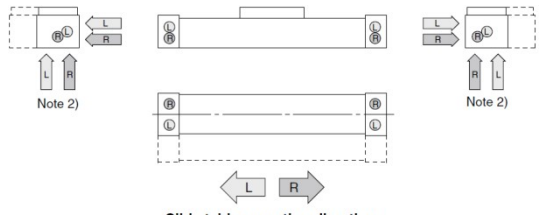

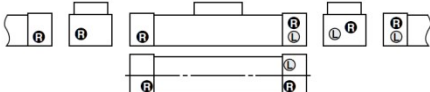
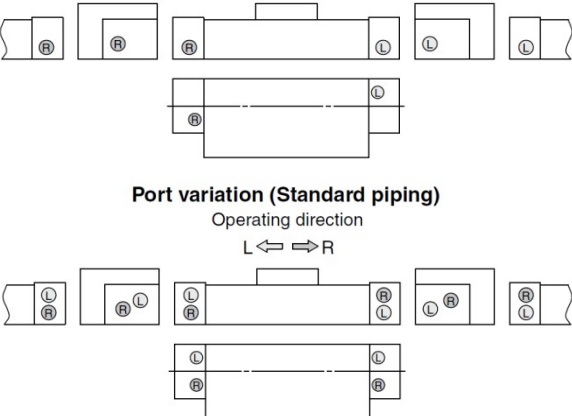
Applicable cylinder	Port variations
MY1B10 MY1H10	 <p style="text-align: center;">Slide table operating direction</p> <p style="text-align: center;">For MY1H10, the port of Note 1) cannot be used.</p>
MY1B16~100 MY1M16~63 MY1C16~63 MY1H16~40	 <p style="text-align: center;">Slide table operating direction</p>
MY1B25,32,40-Z	<p>Standard piping</p> <p style="text-align: center;">Operating direction L ← R →</p>  <p>Centralized piping</p> <p style="text-align: center;">Operating direction L ← R →</p> 
MY1H25,32,40-Z	<p style="text-align: center;">Operating direction L ← R →</p>  <p style="text-align: center;">Port variation (Standard piping)</p> <p style="text-align: center;">Operating direction L ← R →</p> <p style="text-align: center;">Port variation (Centralized piping)</p> <p style="text-align: center;">Operating direction L ← R →</p> <p style="text-align: center;">Port variation (End lock)</p>

Fig. 10-a

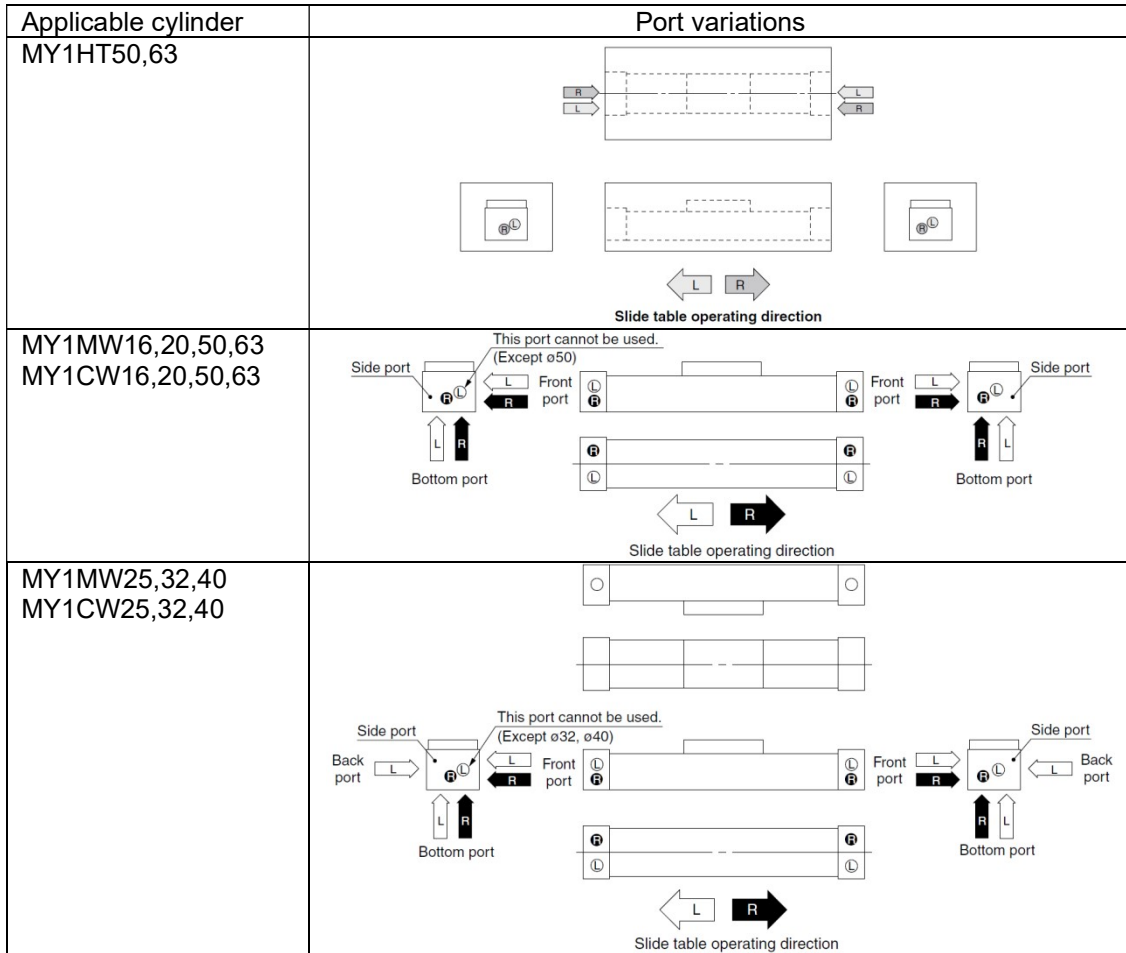


Fig. 10-b

- Refer to Table 2 below for the dimensions of mating parts when bottom ported.

Bore size	$\phi 16$	$\phi 25$	$\phi 40$	$\phi 50$	$\phi 80$
O-ring	C6	C9	C11.2	C15	P22
ϕA dimension	$\phi 4$	$\phi 6$	$\phi 8$	$\phi 10$	$\phi 17$

Table 2

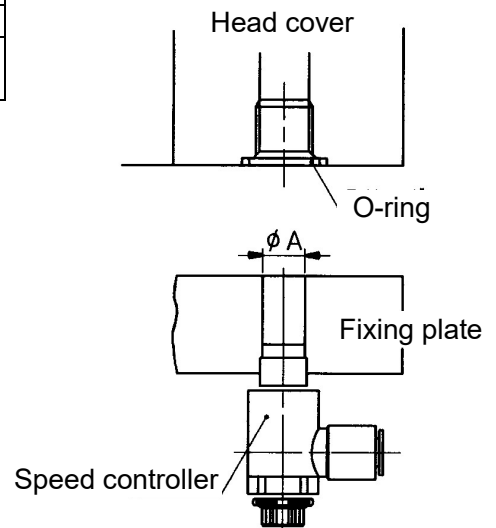


Fig. 11

Caution

1. Before piping

Before piping is connected, the pipe should be thoroughly blown out with air (flushing) or washed to remove chips, cutting oil and other debris from the inside.

2. Sealant tape

When screwing piping or fittings into ports, ensure that chips from the pipe threads or sealing material do not enter the piping.

If sealant tape is used, leave 1.5 to 2 threads exposed at the end of threads.

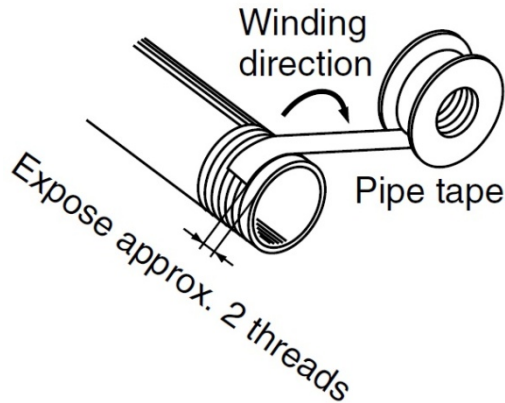


Fig. 12 Wrapping of pipe tape

2-6. Speed control

When the piston speed is adjusted, install SMC AS series speed controller near the air supply port to adjust to the specified speed. There are two methods of speed adjustment, one is to restrict air supplied to the product, and the other is to restrict air exhausted from the product. Normally, the latter method should be adopted.

Caution

1. Use a speed controller to adjust the cylinder drive speed, gradually increasing from a low speed to the desired speed setting.

2. Performance using at constant speed

Mechanical joint type rodless cylinder has a larger fluctuation in speed compared to the rod air cylinder due to its construction.

2-7. Shock Absorbing Mechanism

2-7-1. Rubber cushion (MY1B10,MY1H10)

As shock absorbing stroke of rubber cushion is short, additional cushioning equipment is necessary for stroke adjustment.

2-7-2. Air Cushion

The cushion needle is adjusted as default when the product is shipped. The cushion needle on the cover should be readjusted when the product is put into service, based upon factors such as the size of the load and the operating speed. When the cushion needle is turned clockwise, air is restricted more and the cushion's effectiveness is increased.

Depending on the stroke adjustment amount, air cushion performance will be diminished or will not work.

2-7-3 Stroke Adjusting Unit

- Attachment of the unit body (Other than MY1H10 and MY1HT series)

The unit body can be fixed by evenly tightening the stroke adjusting unit retaining screws (4pcs.). (Fig.13)

- Attachment of the unit body (MY1H10)

1. First, loosen two lock nuts (Fig.14). Then loosen the locking screw by rotating 2 turns.
2. Move the body to the notch before the desired stroke. (Notch is available in 5mm and 10mm in turn)
3. Tighten the holding screw with tightening torque 0.3Nm. Do not apply excess torque during the tightening. The screw (labeled Fixture) that is in the hole of the guide rail prevents displacement of the body. A small amount of torque is required to fix the screw in place.
4. Tighten the lock nut with tightening torque 0.6Nm.

- Changing the the adjustment bolt stroke (Other than MY1HT series)

Loosen the adjustment lock nut. Adjust the stroke using a hexagon wrench, then fix the bolt by the lock nut. (See Fig.13 and Fig.14.)

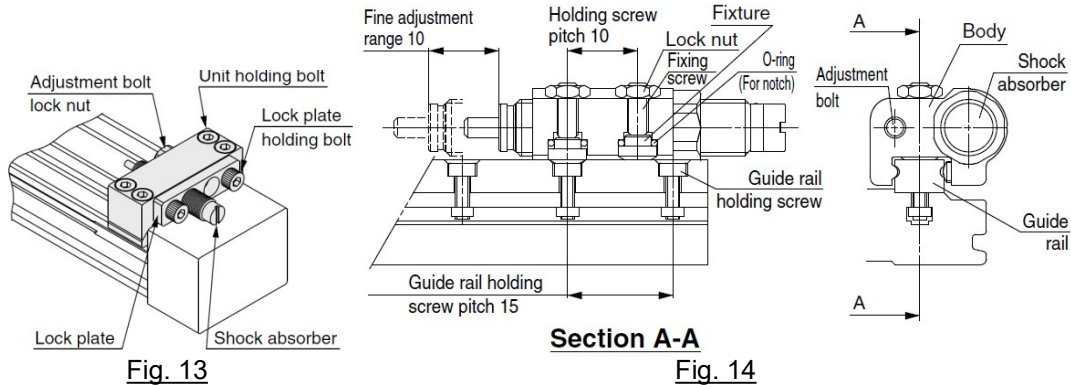


Fig. 13

Fig. 14

- Stopper bolt stroke adjustment (MY1HT series)

Insert the hexagon wrench from the top and loosen the hexagon socket head set screw for 1 turn. Then, adjust the stopper bolt using a flat blade screwdriver. After the adjustment, fix the stopper bolt using the hexagon socket nut.

Bore size (mm)	50	63
A to A Max.	6 to 26	6 to 31
B to B Max.	14 to 54	14 to 74
C	87	102
Max. adjustment range	60	85

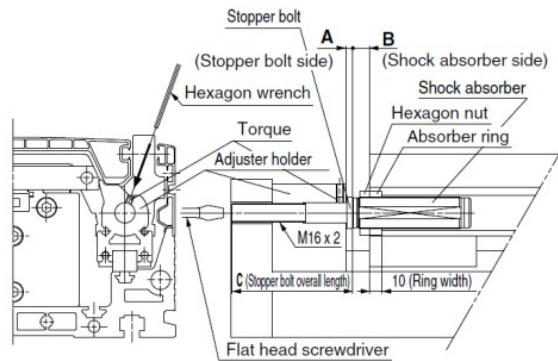


Figure (1) Stroke adjusting section detail

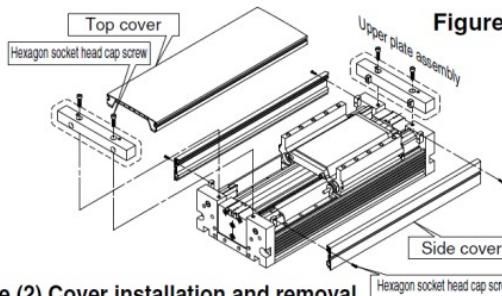


Figure (2) Cover installation and removal

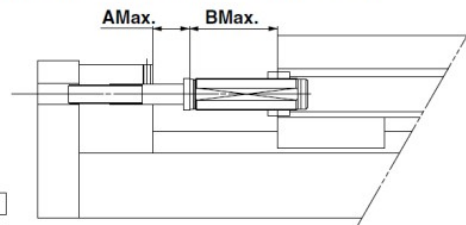


Figure (3) Maximum stroke adjustment detail

Fig. 15

**Stroke adjusting unit
Tightening torque for
retaining screw** Unit (Nm)

Tube I.D. (mm)	Tightening torque	
	MY1B/M/C	MY1H
10	0.4	-
16	0.7	0.7
20	1.8	1.8
25	3.5	1.8
32	5.8	3.5
40	13.8	5.8
50	13.8	-
63	27.5	-

**Stroke adjusting unit lock plate
Tightening torque for
retaining screw** Unit(Nm)

Tube I.D. (mm)	Unit	Tightening torque
20	H	1.2
25	L	1.2
	H	3.3
32	L	3.3
	H	10.0
40	L	3.3
	H	10.0

Table-3 List of Tightening Torque

- Stroke adjustment of the shock absorber (Lock plate type)
Adjust the stroke by rotating the shock absorber after loosening the two lock plate retaining screws. After adjusting the stroke, tighten the lock plate retaining screws uniformly to fix the shock absorber. Tightening of the lock plate retaining screws may slightly bend the lock plate, but the function of the shock absorber and rotation stopper are not affected.
- Stroke adjustment of the shock absorber (Lock nut type)
Adjust the stroke by rotating the shock absorber after loosening the lock nut for shock absorber. After adjusting the stroke, tighten the lock nut to fix the shock absorber.
For MY1HT series, remove covers for adjustment.
- Stroke adjustment of the shock absorber (Slotted)
Adjust the stroke by rotating the shock absorber after loosening the two stroke adjusting unit retaining screws on the shock absorber side. After adjusting the stroke, tighten the retaining screws evenly to fix the shock absorber.

 **Warning**

1. Do not operate the product when the cushion capacity that exceeds the allowable value.

Operation while exceeding the allowable cushion capacity may damage the cylinder and may cause injury or damage to equipment. If operation requires a larger cushion capacity, install an external absorber to prevent impact to the cylinder body. Confirm the rigidity of the equipment after the measure shown above is taken.

2. Do not open the cushion needle too much.

Although, the retaining ring is mounted as the needle retention mechanism, do not open the cushion valve beyond the number of the allowable rotations. Note that it is very dangerous if the cushion needle comes out while air is being supplied to the product.

3. Do not operate the cushion valve in the fully closed state.

It may damage the seal.

 **Caution**

1. Please hold the adjustment bolt so that it will protrude approx. 0.5mm from the shock absorber.

Stroke adjustment shortens the absorber's effective stroke, reducing the absorbing capacity significantly.

2. End lock mechanism adjustment

1. End lock mechanism is adjusted at the time of shipment.
Adjustment at the stroke end for usage is not necessary.
2. Adjust the stroke adjusting unit before the adjustment of the end lock mechanism.
Adjust the end lock mechanism after adjuster bolt and shock absorber have been properly adjusted and secured. Otherwise, locking and unlocking may not be performed properly.
3. In order to unlock the end lock
After loosening the lock finger retaining screw, secure the lock finger by aligning the center of the lock finger to the center of the lock piston.

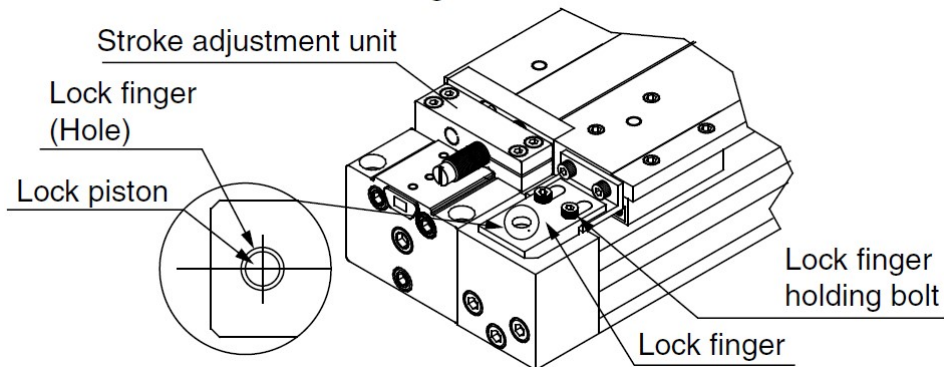


Fig. 16

2-8. Directional control

To change the operating direction of the cylinder, mount an applicable solenoid valve selected from SMC's range of solenoid valves.

Warning

1. Design a circuit to prevent sudden action of a driven object.

When the product is actuated by an exhaust center type directional control valve or when one side of the piston is pressurized with air exhaust, such as when the product is started after the exhaust of the residual pressure from the circuit, driven objects may act suddenly at high speed. In such cases, injury may occur, such as hands or feet getting caught in the machinery, or damage to the machinery itself may occur. Design the machinery using equipment to prevent sudden action.

2. Intermediate stop

Due to the compressibility of air, it is difficult for this product to make a piston stop at the required intermediate position accurately and precisely.

Mechanical joint rodless cylinder has a special seal in the construction, and this causes a minimal amount of external air leakage. A three position closed center type directional control valve may not hold the slide table in the intermediate position for an extended period of time, and the speed may not be controlled when restarting the operation.

Rodless cylinder has the same pressure receiving areas in all the pressure chambers. The table will also stop with a circuit that has air supply from both sides. Use a circuit that controls pressure supply to both sides that uses a three position pressure center type directional control valve for intermediate stop. For holding the intermediate stop for an extended period of time, use a device to prevent it from moving for designing a circuit.

2-9. Mounting of Auto Switch

Mount the auto switch using the bracket corresponding to the mounting groove of the cylinder (table-4) referring to the procedure below. (For the cylinder of "-", all corresponding auto switches can be mounted directly)

Note) Cylinders with switches include the bracket in the package. Order the appropriate bracket separately when only the switch is ordered.

Refer to the catalogue for the correct mounting position.

Cylinder series	Applicable tube I.D.									
	10	16	20	25	32	40	50	63	80	100
MY1B		-		BMG2-012		-		BMG2-012		
MY1B-Z				BMY3-016						
MY1M/MY1MW			-	BMG2-012						
MY1C/MY1CW			-	BMG2-012						
MY1H			-	BMG2-012						
MY1H-Z				BMY3-016						
MY1HT							BMP1-032			

2-9-1. Direct mounting

Insert the auto switch into the switch mounting groove from the cylinder end. Set the switch in the appropriate position and secure it with the switch mounting screws provided with the product using a precision flat head screwdriver.

2-9-2. When switch mounting bracket (BMG2-012) is used

1. Insert the auto switch mounting bracket to the groove of the cylinder for mounting switch (Fig. 17) to set the bracket to the approximate position for the switch.
2. Insert the auto switch to the groove of mounting bracket.
3. After checking the detecting position, tighten the mounting screw (M2.5) to secure the auto switch. The detection position can be changed under the conditions in step 2.

2-9-3. When switch spacer (BMP1-032, BMY3-016) is used

1. Hold the switch spacer then push it into the groove (Fig. 18).
2. Ensure that the switch spacer fits in the correct position.
3. After checking the detecting position, tighten the mounting screw (M2.5) to fix the auto switch.

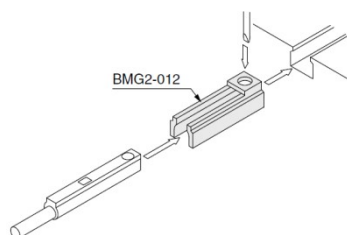


Fig. 17

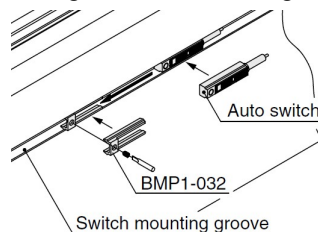


Fig. 18

Note) For the tightening of the mounting screws, use a precision screwdriver with a handle diameter of approximately 5 to 6 mm. Use the tightening torque of approximately 0.05 to 0.1 Nm. As a guide, turn 90° from the position where the mounting screw starts to become tight.

⚠ Caution

1. For the handling of the auto switch, refer to the Operation Manual of the auto switch.
2. Do not let objects drop onto the product or apply with an excessive impact to the product when handling.
3. Avoid wiring that applies repeated bending stress and/or tensile force on the lead wire.
4. It is possible to mount an auto switch in the intermediate position, but the cylinder speed for the switch detection needs to be adjusted to 300 mm/sec. or less in accordance with the response time of the load relay, etc.
5. When operating multiple cylinders with the auto switch in parallel, separate the cylinders, maintaining a minimum separation distance of at least 40mm.
6. Set the cord cover to the auto switch for the cylinder with cover (ø50 and ø63).
In order to avoid the interference of the lead wire and the slider, set the cord cover referring to the procedure of catalog. Product of ø50 or ø63 of auto switch type includes the cord cover in the package.

3. Maintenance

3-1. Inspections

3-1-1. Daily Check

- 1) Smoothness of the operation
- 2) Changes in piston speed and cycle time
- 3) Smooth movement of the slide table for the entire stroke

3-1-2. Regular Check

- 1) Any loose mounting bolts: cylinder mounting, work piece mounting bolts, etc.
- 2) Smoothness of the operation
- 3) Changes in the piston speed and cycle time
- 4) Smooth movement of the slide table for the entire stroke
- 5) Air leaks
- 6) Any scratches or damages to the cylinder
- 7) No drain in the air filter and/or piping
- 8) Increase in the play of the slider (slide table)

When check of the items shown above finds any problems with the cylinder, take the necessary countermeasures referring to the section "4. Troubleshooting".

3-2. Maintenance

Monthly application of grease to the slide bearing (guide) and the dust seal band may lengthen the life.
 Use the grease recommended by SMC.
 Grease pack part number: GR-S-010 (10g), GR-S-020 (20g)

3-3. Replacement Parts

Refer to the catalog the parts that can be replaced.

Warning

1. Maintenance should be performed according to the items above.

Improper handling can cause damage or malfunction of equipment and machinery.

2. Removal of equipment, and supply/exhaust of compressed air.

When the equipment is serviced, first confirm that measures are in place to prevent any dropping of driven objects and run-away of equipment, etc. Then turn off the supply pressure and power, exhaust all compressed air from the system using its residual pressure release function.

Before restarting the equipment, confirm that measures are taken to prevent sudden action.

4. Troubleshooting

Failure	Major causes	Countermeasures
Operation is not smooth. The speed or cycle time has changed. No operation	Misalignment of the workpiece and cylinder axis, or the guide axis of the workpiece and cylinder axis, or application of external force to the cylinder due to usage of a cable bearer, etc.	Realign workpiece and cylinder Confirm that the cylinder operates smoothly without air supplied to the cylinder. Consider using a Floating Bracket (available from SMC) or connecting pipes using a floating mechanism.
	Operation at low speed	Keep the specified range.
	Non conforming air system configuration	Use piping tube, fitting, directional control valve, speed controller etc. of adequate size.
	Lack of grease on the sliding surface	Add grease. (On the top surface and sliding surface of the cylinder tube, approximately 5 g/500 stroke) - Grease is lost due to infiltration of moisture such as drain. - Lubrication is stopped after it is lubricated once. - It is operated in the environment in which it gets liquid splash.
	Insufficient air pressure	Supply adequate pressure. Take necessary countermeasures if any of the following applies. - Pressure source has decreased (including insufficient flow). - Incorrect setting of the regulator. - Clogging, disconnection, bending, or etc. of the piping.
	Insufficient cylinder output	Increase the operating pressure or the cylinder bore size. It should be selected with the sufficient load factor taking resistance of the cylinder and peripherals into consideration.
	Failure of the equipment other than the cylinder	Investigate concerned components one by one. Take necessary countermeasures if any of the following applies. - Failure of the directional control valve. - The speed controller is not adjusted properly. - The speed controller has failed. - Clogging, disconnection, or bending of the piping. - Clogging of the filter, etc.

Failure	Major causes	Countermeasures
Abnormal stroke	Lodging of foreign matter.	Check if there is any foreign substance caught between the slider and the external stopper, etc.
	Foreign substances entered inside the cylinder.	Check if there is any foreign substance such as drain inside the cylinder.
Air blowing-by	Removal of the seal belt	Refer to "How to put back the seal belt when it comes off" on page 5 in the section "1. Product Specifications", and return the seal belt into the specified position.
	Air leak in the value of standard	Replace the seals with the new ones. Take necessary countermeasures if any of the following applies. - Application of a load that is larger than the allowable load. - Operation in an ambient temperature that is out of the operating temperature range. - Shortage of grease. - Foreign matter entering the product.
Air leak	Air leak in the standard value	MY cylinders have a special seal structure that uses a seal belt, so if the air leakage amount is as below, it is a good product. Allowable air leakage Low pressure (0.1MPa): 300cm ³ /min(ANR) or less High pressure (0.8MPa): 425cm ³ /min(ANR) or less
Damage to the parts.	Operation at high speed	Adjust the speed by the speed controller and keep the specified range.
	Excessive impact at the stroke end	Use a shock absorber which absorbs kinetic energy generated by the slider.
	Overload or excessive moment	Select the cylinder model that keeps the guide load factor of the cylinder within the allowable range.
	Action of external force	Structural interference, unbalanced load or over-load may cause damage and/or deformation of the cylinder. Insure these conditions do not exist.
The play of the slider increased.	Wear-out of the slide bearing	The table can be readjusted if the wear of the slide bearing is not significant. Contact SMC for readjustment of the slide table. If the wear is significant, it will be necessary to replace the bearing.
	Wear or damage to the cam follower guide	Refer to the item "Damage to the parts" shown above, and take the countermeasures provided.
	Wear-out or damage of the linear guide	Refer to the item "Damage to the parts" shown above, and take the countermeasures provided.
	Damage of the parts around the bearing (guide)	Refer to the item "Damage to the parts" shown above, and take the countermeasures provided.

Caution

- 1. Contact SMC if cylinder needs to be disassembled. Air leaks may occur if the seals are damaged during disassembly. Disassembling or modifying the internal wiring will void the product's warranty. If you need it warranted, ask SMC for repair.**

Revision history

-:Created in new format
1:"Safety Precautions"revised
Review of writing content
2:P21 Added about air leaks

SMC Corporation

Tel: + 81 3 5207 8249 Fax: +81 3 5298 5362
URL <https://www.smcworld.com>

Note: Specifications are subject to change without prior notice and any obligation on the part of the manufacturer.
© SMC Corporation All Rights Reserved