



# Operation Manual

PRODUCT NAME

Cylinder with lock

MODEL / Series / Product Number

MWB\*32&100-\*  
MWB\*32&100TN-\*  
MWB\*32&100TF-\*

**SMC Corporation**

# Contents

Safety Instructions	P. 2
1. Product Specifications	P. 4
1-1. Cylinder specifications	
1-2. Lock specifications	
1-3. Stop accuracy	
1-4. Precautions on model selection	P. 5
2. Installation and Handling	P. 9
2-1. Air supply	
2-2. Design	
2-3. Mounting	
2-4. Operating environment	
2-5. Speed control	
2-6. Cushion	
2-7. Directional control	
2-8. Pneumatic circuit	
2-9. Adjustment and Operation	
3. How to use	P. 17
3-1. Usage	
3-2. Lock release mechanism	
3-3. Auto switch	
3-4. Wiring method and examples of auto switches	
4. Maintenance	P. 33
4-1. Consumable parts	
4-1-1. Seal kit	
4-1-2. Storage of seals	
4-2. Lock unit replacement	
4-3. Checks	
4-3-1. Inspection points	
4-3-2. Inspection interval	
4-4. Replacement of seals	
4-4-1. Disassembly / Reassembly	
4-4-2. Removal of seals	
4-4-3. Grease	
4-4-4. Mounting of seals	
5. Troubleshooting	P. 40
6. Maintenance	P. 42
6-1. Construction	



# Safety Instructions

These safety instructions are intended to prevent hazardous situations and/or equipment damage. These instructions indicate the level of potential hazard with the labels of “**Caution**,” “**Warning**” or “**Danger**.” They are all important notes for safety and must be followed in addition to International Standards (ISO/IEC)\*1), and other safety regulations.

\*1) ISO 4414: Pneumatic fluid power - General rules and safety requirements for systems and their components  
ISO 4413: Hydraulic fluid power - General rules and safety requirements for systems and their components  
IEC 60204-1: Safety of machinery - Electrical equipment of machines - Part 1: General requirements  
ISO 10218-1: Robots and robotic devices - Safety requirements for industrial robots - Part 1: Robots  
etc.

	<b>Danger</b>	<b>Danger</b> indicates a hazard with a high level of risk which, if not avoided, will result in death or serious injury.
	<b>Warning</b>	<b>Warning</b> indicates a hazard with a medium level of risk which, if not avoided, could result in death or serious injury.
	<b>Caution</b>	<b>Caution</b> indicates a hazard with a low level of risk which, if not avoided, could result in minor or moderate injury.

## **Warning**

### **1. The compatibility of the product is the responsibility of the person who designs the equipment or decides its specifications.**

Since the product specified here is used under various operating conditions, its compatibility with specific equipment must be decided by the person who designs the equipment or decides its specifications based on necessary analysis and test results. The expected performance and safety assurance of the equipment will be the responsibility of the person who has determined its compatibility with the product. This person should also continuously review all specifications of the product referring to its latest catalog information, with a view to giving due consideration to any possibility of equipment failure when configuring the equipment.

### **2. Only personnel with appropriate training should operate machinery and equipment.**

The product specified here may become unsafe if handled incorrectly. The assembly, operation and maintenance of machines or equipment including our products must be performed by an operator who is appropriately trained and experienced.

### **3. Do not service or attempt to remove product and machinery/equipment until safety is confirmed.**

1. The inspection and maintenance of machinery/equipment should only be performed after measures to prevent falling or runaway of the driven objects have been confirmed.
2. When the product is to be removed, confirm that the safety measures as mentioned above are implemented and the power from any appropriate source is cut, and read and understand the specific product precautions of all relevant products carefully.
3. Before machinery/equipment is restarted, take measures to prevent unexpected operation and malfunction.

### **4. Our products cannot be used beyond their specifications. Our products are not developed, designed, and manufactured to be used under the following conditions or environments. Use under such conditions or environments is not covered.**

1. Conditions and environments outside of the given specifications, or use outdoors or in a place exposed to direct sunlight.
2. Use for nuclear power, railways, aviation, space equipment, ships, vehicles, military application, equipment affecting human life, body, and property, fuel equipment, entertainment equipment, emergency shut-off circuits, press clutches, brake circuits, safety equipment, etc., and use for applications that do not conform to standard specifications such as catalogs and operation manuals.
3. Use for interlock circuits, except for use with double interlock such as installing a mechanical protection function in case of failure. Please periodically inspect the product to confirm that the product is operating properly.



# Safety Instructions

## Caution

**We develop, design, and manufacture our products to be used for automatic control equipment, and provide them for peaceful use in manufacturing industries.**

**Use in non-manufacturing industries is not covered.**

Products we manufacture and sell cannot be used for the purpose of transactions or certification specified in the Measurement Act.

The new Measurement Act prohibits use of any unit other than SI units in Japan.

## Limited warranty and Disclaimer/Compliance Requirements

The product used is subject to the following “Limited warranty and Disclaimer” and “Compliance Requirements”. Read and accept them before using the product.

### Limited warranty and Disclaimer

1. The warranty period of the product is 1 year in service or 1.5 years after the product is delivered, whichever is first.\*2)  
Also, the product may have specified durability, running distance or replacement parts. Please consult your nearest sales branch.
2. For any failure or damage reported within the warranty period which is clearly our responsibility, a replacement product or necessary parts will be provided.  
This limited warranty applies only to our product independently, and not to any other damage incurred due to the failure of the product.
3. Prior to using SMC products, please read and understand the warranty terms and disclaimers noted in the specified catalog for the particular products.

**\*2) Vacuum pads are excluded from this 1 year warranty.**

A vacuum pad is a consumable part, so it is warranted for a year after it is delivered.

Also, even within the warranty period, the wear of a product due to the use of the vacuum pad or failure due to the deterioration of rubber material are not covered by the limited warranty

### Compliance Requirements

1. The use of SMC products with production equipment for the manufacture of weapons of mass destruction (WMD) or any other weapon is strictly prohibited.
2. The exports of SMC products or technology from one country to another are governed by the relevant security laws and regulations of the countries involved in the transaction. Prior to the shipment of a SMC product to another country, assure that all local rules governing that export are known and followed.

## 1. Product Specifications

### 1-1. Cylinder specification

Bore size (mm)	32	40	50	63	80	100
Operating method	Double acting/single rod					
Fluid	Air					
Proof pressure	1.5MPa					
Max. operating pressure	1.0MPa					
Min. operating pressure	0.08MPa					
Ambient and fluid temperature Operating fluid temperature	Without auto switch: -10°C to 70°C With auto switch: -10°C to 60°C					
Lubrication	Not required (non-lube)					
Piston speed	50~1,000mm/s *					
Allowable stroke length tolerance [mm]	~250st: $\begin{smallmatrix} +1.0 \\ 0 \end{smallmatrix}$ , 251~1,000st: $\begin{smallmatrix} +1.4 \\ 0 \end{smallmatrix}$ , 1,001~1,500st: $\begin{smallmatrix} +1.8 \\ 0 \end{smallmatrix}$ , 1,501~2000st: $\begin{smallmatrix} +2.2 \\ 0 \end{smallmatrix}$					
Cushion	Air cushion or rubber bumper					
Port size (Rc, NPT, G)	1/8	1/4	3/8	1/2		
Mounting type	Basic type, axial foot type, rod flange type, head flange, single clevis, double clevis, shaft type trunnion.					

\* Load is limited depending on the piston speed at the time of locking, mounting direction and operating pressure.

**\*\* Use the product so that the kinetic energy does not exceed the allowable value of the cylinder.**  
(Refer to "Allowable kinetic energy of the cylinder "(Page 8)".)



### Warning 2

#### -Confirm the specifications.

This product is designed only for use in compressed air systems including vacuum. Do not operate at pressures or temperatures outside of the specification, as this could cause damage or malfunction (Refer to the specifications.)  
SMC does not guarantee against any damage if the product is used outside of the specification range.

#### -Confirm the applicable specification range.

These product specifications apply to all standard strokes including intermediate strokes. Product specifications may not apply to long stroke and order-made products (-XB□, -XC□)

### 1-2. Lock unit specifications

Bore size (mm)	32	40	50	63	80	100
Locking operation type	Exhaust locking					
Max. operating pressure	1.0MPa					
Min. operating pressure	0.3MPa or more					
Locking direction	Both directions					
Holding force (Maximum static load)(N) *	680	980	1570	2450	3920	6080

\* The holding force (max. static load) shows the maximum capability and does not show the normal holding capability.  
Choose the cylinder based on the Selection graph (Page 6).

### 1-3. Stop accuracy

Bore size (mm)	32	40	50	63	80	100
Locking type	Exhaust locking					
Stop accuracy	±1.0					
Condition	<ul style="list-style-type: none"> <li>•Mounting orientation ... Horizontal</li> <li>•Supply pressure ... 0.5MPa</li> <li>•Piston speed ... 300mm/s</li> <li>•Load condition ... Upper limit of allowable value</li> </ul> Solenoid valve for lock Mounted to the lock release port Value shown is based on testing and the largest value is quoted. (Test repeated 100 times)					

### 1-4. Precautions on model selection

#### Caution

- ① Choose the optimum bore size based on the applications operating conditions such as load, travel distance (stroke), stroke time, mounting orientation, operating pressure, etc.
- ② Attention should be taken so that the operating speed does not exceed the max. speed for the cylinder. Adjust the maximum speed of cylinder using the speed controller so that the load travels the stroke slower than the stroke time,
- ③ Stroke time means the time taken for the load moving from the start of the stroke to the end without intermediate stop.
- ④ When the cylinder stroke and travel distance of the load is different, such as double speed mechanism as Fig.1, select the model based on the travel distance of the load.

Step 1	Calculate the maximum speed of the load: V
--------	--

Calculate the maximum speed of the load, V (mm) from travel time of the load, t (s) and stroke, st (mm).

Graph 1

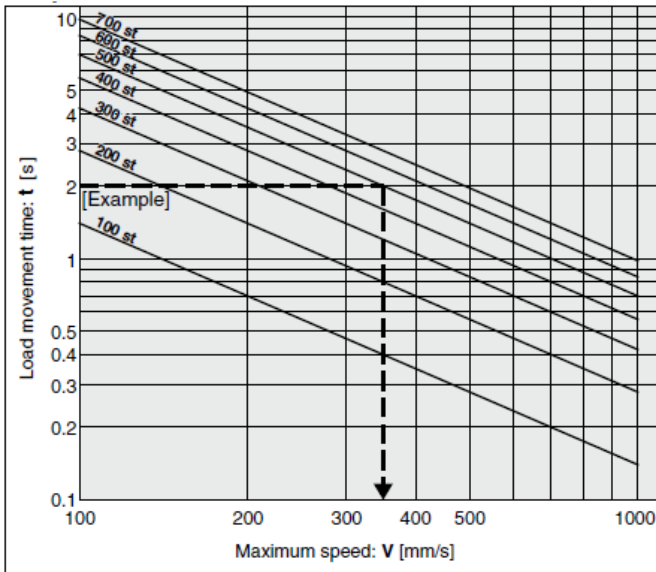

Example
---------

- Load weight:  $m=50\text{kg}$
- Travel distance:  $st=500\text{mm}$
- Positioning time:  $t=2\text{s}$
- Load:  
Vertically downwards = Load in extending direction of the rod
- Operating pressure:  $P=0.4\text{MPa}$

- Step 1: Based on Graph 1  
Calculate the maximum speed of the load.  
 $\therefore$  Max speed  $V \approx 350\text{mm/s}$
- Step 2: Select Graph 6 based on the load conditions and operating pressure. According to the max. speed,  $V \approx 350\text{mm/s}$  calculated above and load weight  $m=50\text{kg}$ ,  $\therefore \phi 63$ , which means the bore size of MWB shall be larger than  $\phi 63$ .
- Step 3: Confirm allowable kinetic energy  
Step 4: Check the allowable lateral load

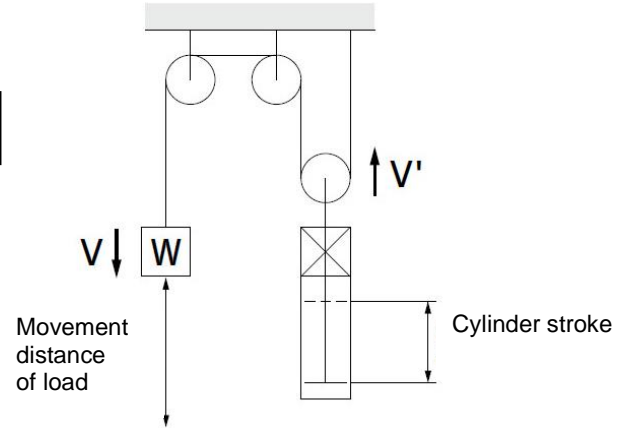

Fig. 1 Double speed mechanism

Step 2	Calculate the cylinder tube I.D.
--------	----------------------------------

Select the appropriate graph for the load conditions and operating pressure. Find the intersection of the max. speed and load weight as the Step 1 to select the bore size life above the intersection.

Load	Operating pressure
------	--------------------

Load applied perpendicularly to the rod  
(Received by guide)

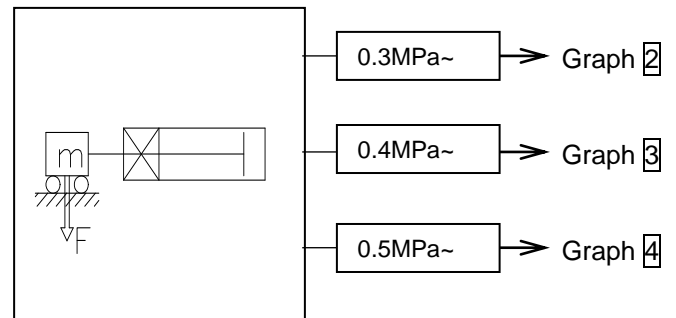

Load applied in extending direction of the rod  
Load applied in retracting direction of the rod

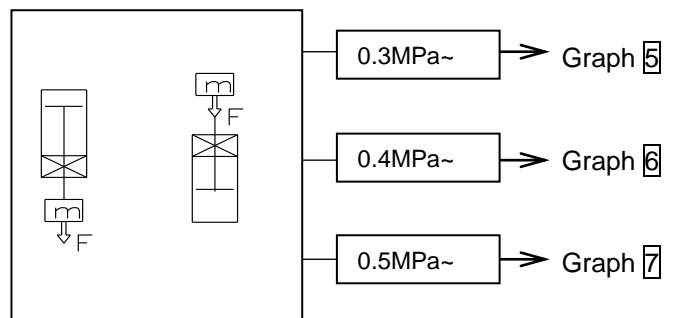

# Selection graph

**Graph 2**  $0.3\text{MPa} \leq P < 0.4\text{MPa}$

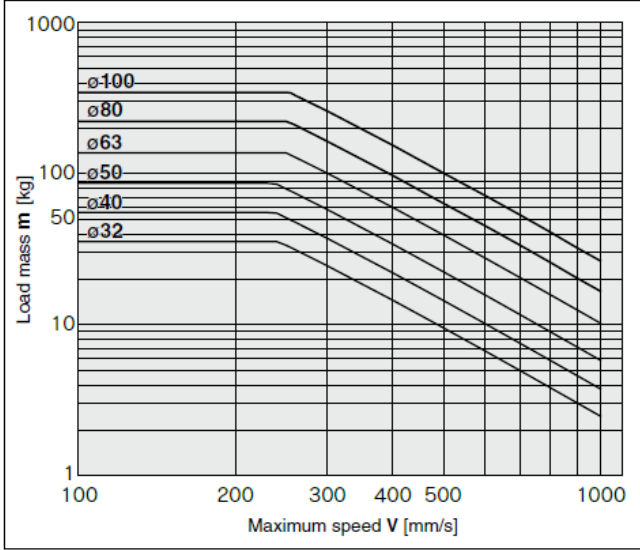

**Graph 5**  $0.3\text{MPa} \leq P < 0.4\text{MPa}$

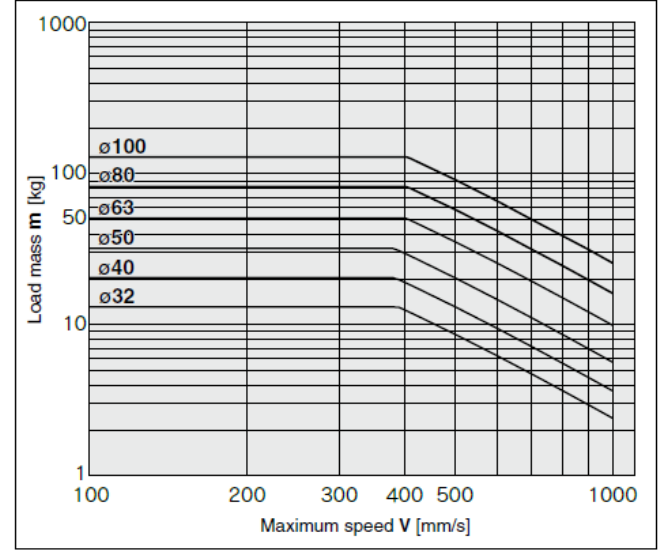

**Graph 3**  $0.4\text{MPa} \leq P < 0.5\text{MPa}$

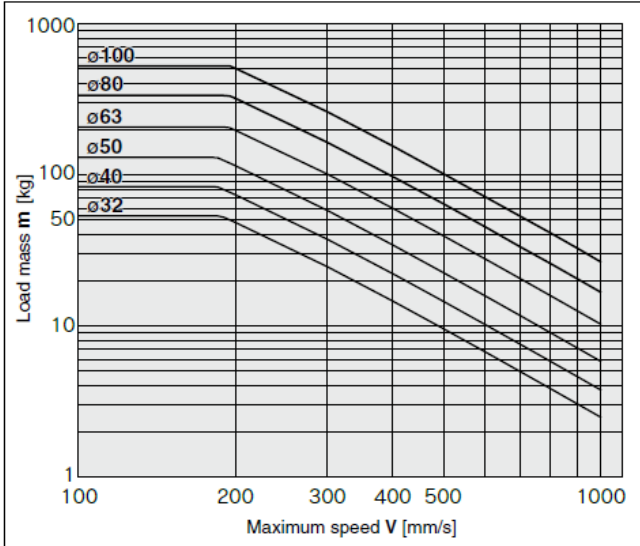

**Graph 6**  $0.4\text{MPa} \leq P < 0.5\text{MPa}$

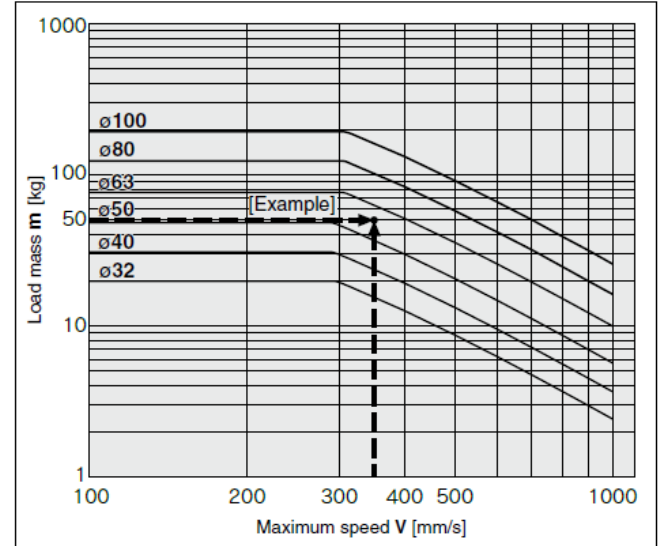

**Graph 4**  $0.5\text{MPa} \leq P$

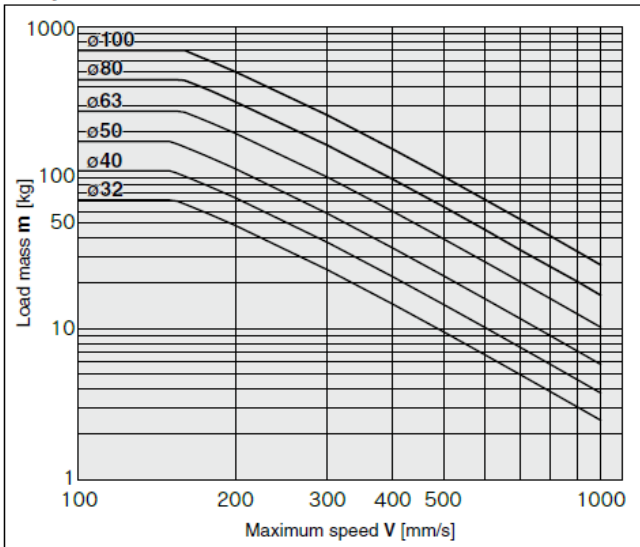

**Graph 7**  $0.5\text{MPa} \leq P$

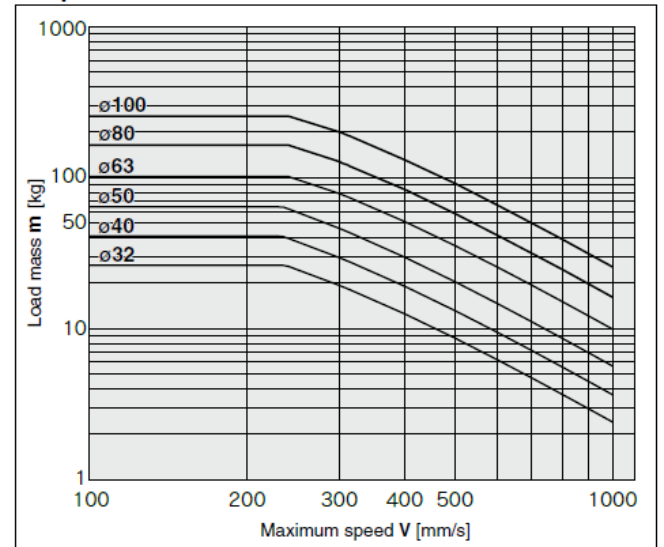

Step 3

Make sure that the allowable kinetic energy of cylinder is not exceeded.

Based on the Graph 8, confirm that the allowable kinetic energy of the cylinder is not exceeded at the load weight and maximum speed selected in Step 1 and 2.

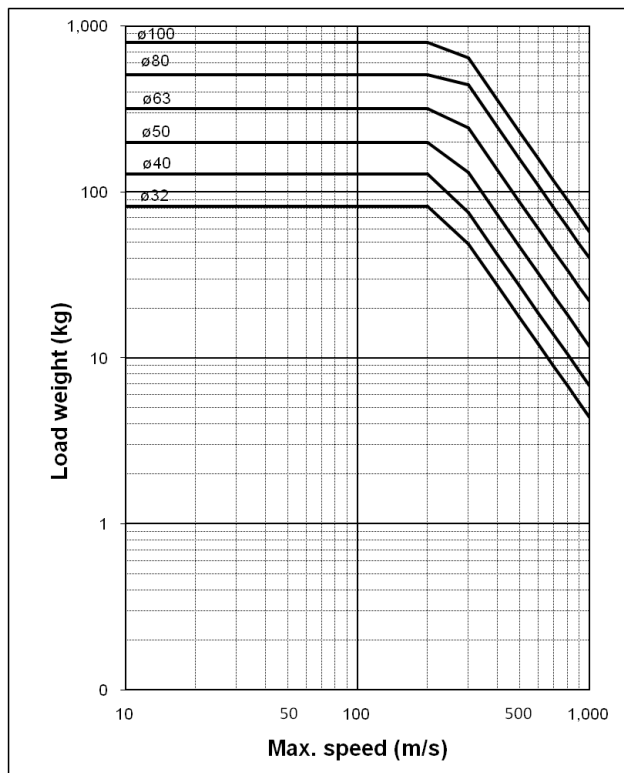

1) Air cushion is effective

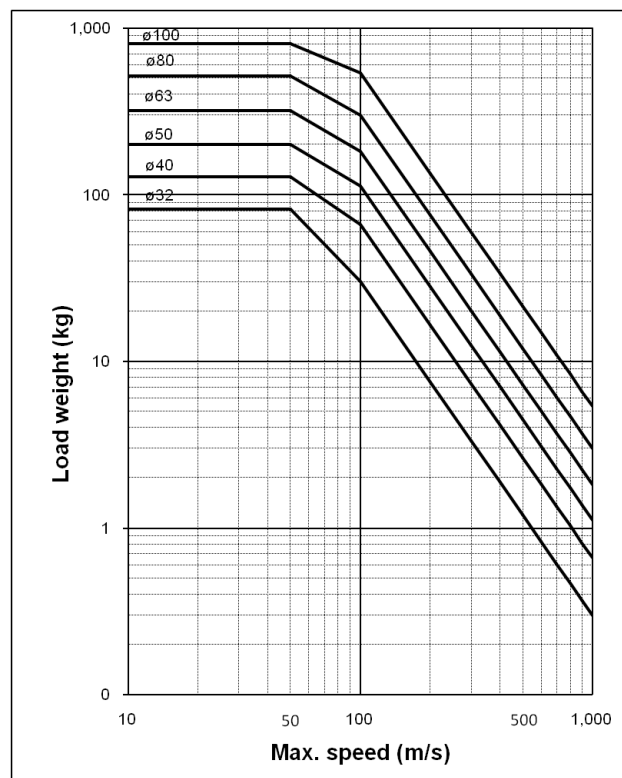

2) Air cushion is not utilized

Graph 8. Allowable kinetic energy of the cylinder



### Warning

• Use the product so that the kinetic energy does not exceed the allowable value of the cylinder.

Operation with a kinetic energy over the allowable value can break the product and cause injury or damage to equipment. If the cylinder is used with an excessive kinetic energy, install an external absorber to prevent impact from acting on the cylinder body. If these countermeasures are taken, confirm the rigidity of the equipment carefully.



### Caution

• When a rubber cushion is used, there will be a slight bounce at the stroke end.

• The allowable kinetic energy of the cylinder is shown without the intermediate stop or emergency stop. Please refer to Page 6 and 7 for the kinetic energy with intermediate or emergency stop.



Step 4	Lateral load applied to the rod end shall not exceed the limit of allowable load.
--------	---

Make sure that lateral load applied to the piston rod end does not exceed the allowable load limit referring to the Graph 9.

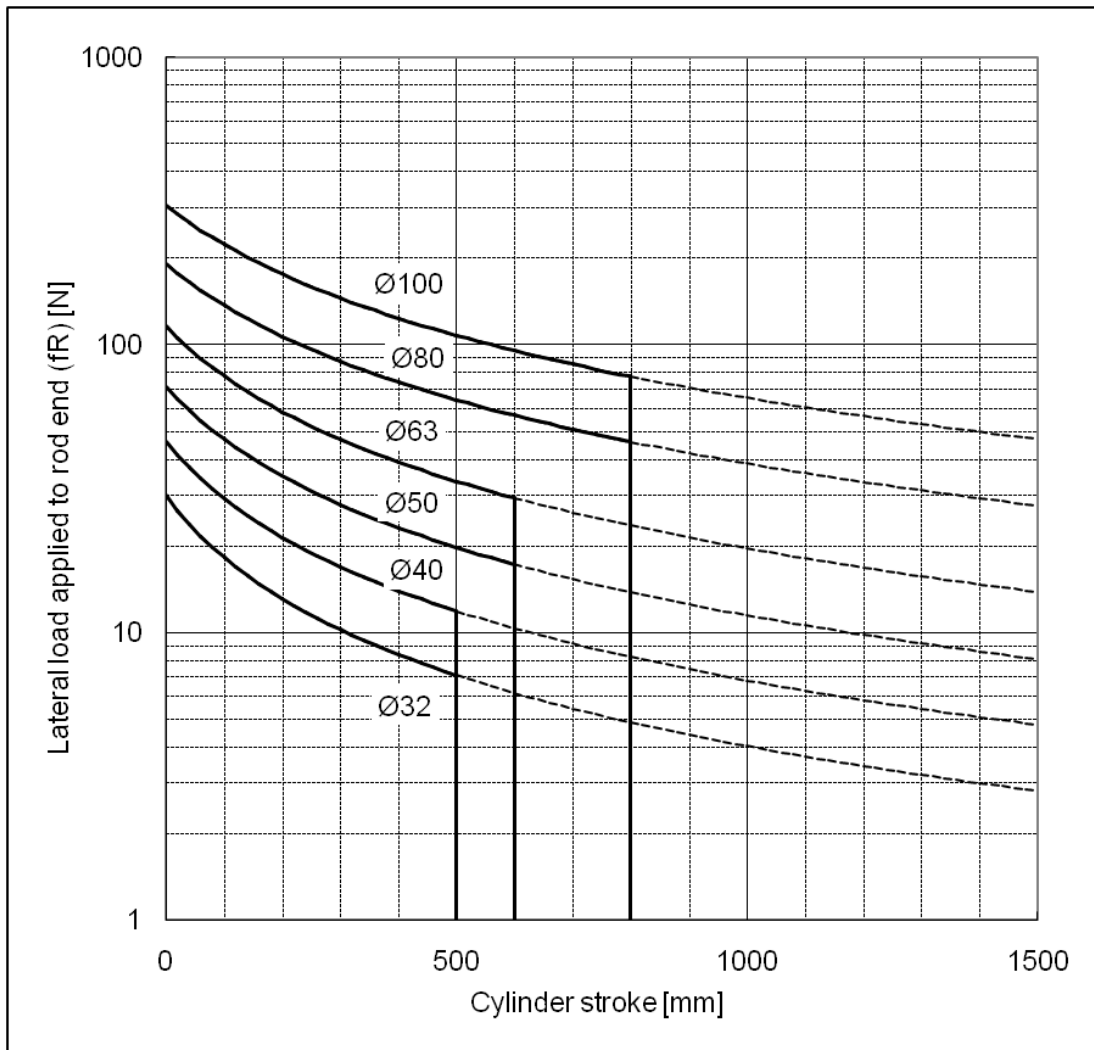
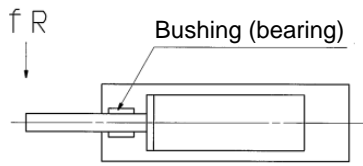

**Chart 9 Allowable lateral load applied to rod end**

The bold solid lines in Chart 9 show the allowable lateral load on the cylinder for a certain stroke length.

**Warning**

• **Use the product with its allowable lateral load or less**

If a load exceeding the allowable lateral load is applied to the piston rod end, the bearing, the piston seal or the piston could experience a failure. When the allowable lateral load is exceeded, protect the cylinder from excessive lateral load by installing the external guide to the cylinder.

## 2. Installation and Handling

### 2-1. Air supply

- ① The air supplied to the cylinder should be filtered by SMC AF series air filter and regulated to the specified set pressure by SMC AR series regulator.



#### **Warning** 2

• **Type of fluids**

Use compressed air.

• **When there is a large amount of condensate**

Compressed air containing a large amount of condensate can cause the malfunction of pneumatic equipment. An air dryer or water droplet separator should be installed upstream from the filters.

• **Drain flushing**

If condensate in the drain bowl is not emptied on a regular basis, the bowl will overflow and this may cause the malfunction of pneumatic equipment. If the drain bowl is difficult to check and remove, installation of a drain bowl with an auto drain option is recommended.

• **Use clean air.**

Do not use compressed air which contains chemicals, synthetic oils containing organic solvents, salts or corrosive gases, etc., as this can cause damage or a malfunction.



#### **Caution** 2

• When low dew point air is used as the fluid, degradation of the lubrication properties inside the equipment may occur, resulting in reduced reliability (or reduced service life) of the equipment.

• **Install an air filter.**

Install an air filter upstream near the valve. Select an air filter with a filtration size of 5µm or smaller.

• **Therefore, take appropriate measures to ensure air quality, by providing an after cooler, or water separator, if needed.**

Compressed air that contains excessive foreign material may cause malfunction of valves and other pneumatic equipment. Therefore, take appropriate measures to ensure air quality, such as by providing an after cooler, air dryer, or water separator.

• **Ensure that the fluid temperature and ambient temperature are within the specified range.**

When operating at temperatures below 5°C, moisture in the circuit may freeze and cause breakage of seals or a malfunction. Corrective measures should be taken to prevent freezing.

- ② Lubrication of non-lubricating cylinder

• **Cylinder part**

The product has been lubricated during manufacturing, so it does not require lubrication in service. If a lubricant is used in the system, use turbine oil Class 1 (with no additive) ISO VG-32. Do not use machine oil or spindle oil. Stopping lubrication may lead to a malfunction as the new lubricant will have displaced the original lubricant. Therefore, lubrication must be continued once it has been started. If turbine oil is used, refer to the Material Safety Data sheet (MSDS) of the turbine oil.

• **Lock unit**

Regular or continuous application of oil to the lock unit may reduce locking force.

For detailed information regarding the quality of the compressed air described above, refer to SMC's "Air Cleaning Systems".

## 2-2. Design

The compatibility of the product is the responsibility of the person who designs the equipment or decides its specifications.

### **Warning**

- **There is a possibility of dangerous sudden action by cylinders if force is changed due to twisting of sliding parts of machinery.**

In such cases, human injury may occur; e.g., by catching hands or feet in the machinery, or damage to the machinery itself may occur. Therefore, the machine should be designed to operate smoothly and avoid such dangers.

- **A protective cover is recommended to minimize the risk of personal injury.**

If the driven object or moving parts of the product will pose a hazard to humans, a construction that prevents direct contact with the exposed area must be provided.

- **Securely tighten all stationary parts and connected parts, so that they will not become loose.**

Be certain to adopt a reliable connecting method if the cylinder is used frequently, or if it is used in a location that is exposed to a large amount of vibration.

- **A deceleration circuit or shock absorber etc., may be required.**

When a driven object is operated at high speed or the load is heavy, the cylinder's cushion will not be sufficient to absorb the shock. Install a circuit to reduce the speed before cushion or install an external shock absorber to relieve the shock. Confirm the rigidity of the equipment after the measure shown above is taken.

- **Design the system so that an external force exceeding the maximum output does not apply to the product.**

The product can break, causing a risk of personal injury or damage to equipment.

- **The product generates a large force. Install on a sufficiently rigid mounting base, taking this force into consideration.**

There is a risk of personal injury or damage to equipment.

- **Power failure may cause the circuit pressure to decrease.**

- **Consider a possible loss of power source.**

Measures should be taken to prevent personal injury and damage to equipment in the event that there is a power malfunction to equipment controlled by air pressure, electricity or hydraulics, etc.

- **Consider the behavior of an emergency stop.**

Devise a safety system so that if a person engages the emergency stop, or if a safety device is tripped during a system malfunction such as a power outage, the movement of the cylinder will not cause a hazard to humans or damage the equipment.

- **Avoid using cylinders for synchronized operations.**

Even if multiple pneumatic cylinders are initially set to the same speed, their speeds may vary due to changes in operating conditions. Therefore, do not design a circuit which is to transfer one load by simultaneous operation of more than one cylinder.

- **Consider the action when operation is restarted after an emergency stop or abnormal stop.**

Design the machinery so that personal injury or damage to equipment will not occur upon restart of operation. When the cylinder has to be reset at the starting position, install safety manual control equipment.

### **Caution** 2

- **Avoid having a large gap between the clevis and mating bushing, as this exposes the pin to a bending load.**

- **Do not touch the cylinder during high speed and high frequency operation.**

When the cylinder is operating at high speed and high frequency, the surface temperature of the cylinder tube increases, and may cause injury to personnel.

- **Do not use the air cylinder as an air-hydro cylinder.**

If the working fluid of the air cylinder is turbine oil, oil leakage can result.

- **The oil adhered to the cylinder is grease oil.**

- **The base oil of grease may seep out.**

The base oil of grease in the cylinder may seep out from the tube, cover, or rod sliding part depending on the operating conditions (ambient temperature of 40°C or more, pressurized condition, low frequency operation, etc.). Be especially careful when a clean environment is required.

## 2-3. Mounting

The foot mounting cylinder has a hole in the foot to drive a pin into for accurate positioning and fixing.

### **Caution**

- **Do not apply excessive lateral load to the piston rod.**

Please refer to Chart 1. Allowable lateral load applied to rod end. (Page 9)

### **Warning**

- **Make sure to release the lock before connecting the load to the rod end.**

- a. If the load is connected to the rod end during the locked state there is a risk that the rotating force caused by the load will exceed the holding force on the piston rod, breaking the lock mechanism.
- b. When connecting the rod end and load, connect piping to the lock release port to supply air pressure of 0.3MPa or more, or release the lock using the release bolt (Page 18).

### **Caution**

- **Do not apply eccentric load to the piston rod.**

Alignment of the center of gravity of the load and the center of the cylinder is necessary. When there is a large amount of misalignment, eccentric wear or damage of the piston rod can result due to the moment of inertia caused by the stopping impact when locking.

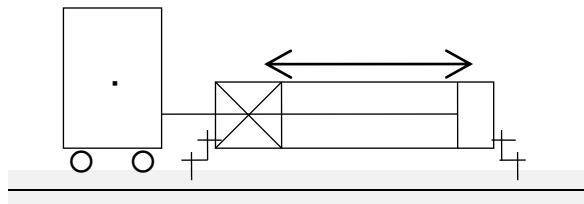

× Misalignment of the center of gravity of the load and the shaft center of the cylinder.

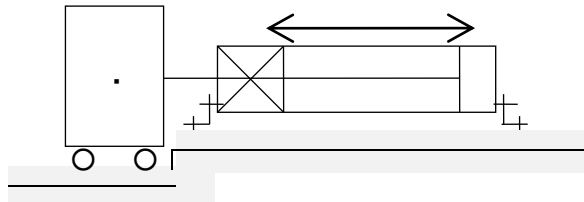

○ Center of gravity of the load and the shaft center of the cylinder are aligned

Note) Also applicable when the generated moment is absorbed by an effective guide.

**Fig. 2 Center of gravity of the load mounted to the rod end**

- **Do not scratch or dent the sliding parts of the piston rod.**

Damage to the seals may lead to air leakage and locking failure.

- **Do not apply loads with impact, strong vibration or rotational force while the lock mechanism is activated.**

External impact load, strong vibration or rotating force may break or reduce the life of lock part.

- **Prevent seizure of the rotating parts of mounting bracket.**

Prevent the seizure of rotating parts (pins, etc.) of mounting brackets by applying grease.

- **Do not use the product until you have verified that the equipment can operate properly.**

After installation or repair, apply compressed air and power supplies to the equipment and perform appropriate functional and leakage inspections to make sure the equipment is mounted properly.

- **When the support brackets are replaced, use a hexagon wrench as specified below.**

Lock unit model	Bolt	Hexagon wrench size	Tightening torque (N·m)
MWB*32 MWB*40	MB-32-48-C1247	4	5.1
MWB*50 MWB*63	MB-32-48-C1249	5	11
MWB*80 MWB*100	Foot	MB-80-48AC1251	25
	Other	MB-80-48BC1251	

- There is a vent hole on the element. If the ventilation is not adequate, there will be locking/ unlocking delay or operation failure. Install the cylinder so that the element is not covered. Keep 10mm or more away from the wall.

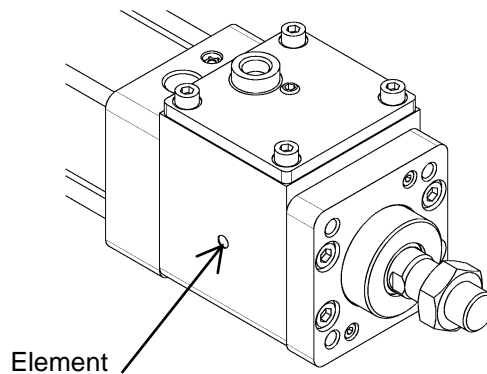

Fig. 3 Lock unit element

#### 2-4. Operating environment



#### Warning

- Do not use in an atmosphere having corrosive gases, chemicals, sea water, water, water steam, or where there is direct contact with any of these.
- Provide a protective cover if the product is used in direct sunlight.
- Do not operate in environments subject to heavy vibration and/or impact.
- Do not mount the product in locations where it is exposed to radiant heat.
- Install a cover over the rod if it is used in an area that is dusty, or in an environment in which water or oil splashes on the cylinder.
- When using auto switches, do not operate in an environment with strong magnetic fields.
- Grease oil can decrease depending on the properties of the compressed air used with the pneumatic equipment, external environment and operating conditions. This may reduce the lubrication performance and shorten the life of the product.
- Avoid storing the product in humid conditions.

Store the product with the piston rod retracted and avoid humidity, in order to prevent generation of rust.



#### Caution

2

- Machined parts of the piston rod and tie rod are not plated. Be careful there is possibility to occur rust during usage or long term storage.
- **Preparation before piping**  
Before piping, perform air blow (flushing) or cleaning to remove any cutting chips, cutting oil, dust, etc. from the piping and fittings.
- **Winding of sealant tape**  
When screwing together pipes and fittings, etc., be certain that chips from the pipe threads and sealant do not get inside the pipe.  
Also, when the sealant tape is used, leave approx. 1 thread ridge exposed at the end of the threads.

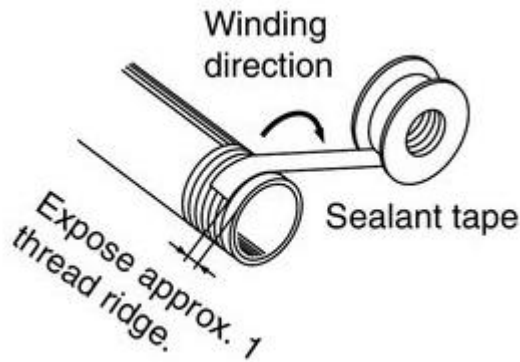

Fig. 4 Sealant tape

## 2-5. Speed control

- 1) When the piston speed is adjusted, install SMC AS series speed controller near the air supply port to adjust to the specified speed.
- 2) Use speed controllers to adjust the speed. There are two types of speed controllers for adjusting the speed: one is to regulate the supplied air into the cylinder (meter-in control), and another is to regulate the exhausted air from the cylinder (meter-out control). As the cylinder operation may be unstable with the meter-in control type speed controller, the meter-out control type speed controller is generally used for double acting cylinders.

### **Caution**

Piston speed should be controlled gradually from low speed with a speed controller fully closed to the specified speed.

## 2-6. Cushion

### **Caution**

- Cylinder cushions are adjusted properly before shipping, re-adjust the cushion valve on the cover according to the load and the operating speed.
- By turning the cushion needle in clockwise direction, air is restricted more and the cushion's effectiveness is improved. When the cushion valve is turned counter-clockwise, the restriction becomes larger and the cushion's effectiveness is decreased.
- If the cushion valve is fully closed, the piston may bounce at the stroke end, not move through the full stroke, or the cushion seal may be damaged due to excessive pressure. Do not use the cushion valve in this way.
- Activate the air cushion when operating the cylinder. If this is not done, the piston rod assembly or the tie-rods will be damaged when the allowable kinetic energy exceeds the values shown in Chart 8 (page 8).

### **Warning**

- **Do not open the cushion valve beyond the stopper.**

Crimping (Ø32) or a retaining ring (Ø40~Ø100) is provided to prevent the accidental removal of the cushion valve. Do not open the valve beyond the mechanism. If air is supplied without confirming above, the cushion valve may shoot out from the cover.

Bore size (mm)	Hexagon wrench size of cushion valve
32,40	2.5
50,63	3
80,100	4

- **Ensure to use an air cushion at cylinder stroke end.**

If the cushion valve is fully open, select the cylinder with bumper. If the bumper is not used, the breakage of tie rod or piston rod assembly can result.

## 2-7. Directional control

To switch the operating direction of the cylinder, mount an applicable solenoid valve selected from SMC's range of solenoid valves.



### **Warning**

#### **•Design a circuit to prevent sudden action of a driven object.**

When the product is actuated by an exhaust center type directional control valve or when one side of the piston is pressurized with air exhaust, such as when the product is started after the exhaust of the residual pressure from the circuit, driven objects may act suddenly at high speed. In such cases, injury may occur, such as hands or feet getting caught in the machinery, or damage to the machinery itself may occur. Design the machinery to avoid such dangers.

## 2-8. Pneumatic circuit

### Warning

- ① **Use the pneumatic circuit which applies balance pressure to the both sides of the piston when locking.**

To prevent sudden extension when operation restarts or lock is released, control the cylinder to make balancing pressure applied to both sides of the piston so that the force generated in the operating direction of the piston due to load can be counteracted.

- ② **Effective area of the lock release solenoid valve shall be more than 50% of that of the cylinder actuating solenoid valve. The lock release solenoid valve should be installed closer to the cylinder than the solenoid valve actuating the cylinder.**

If the effective area of the lock release solenoid valve is small, or the solenoid valve is far from the cylinder, it takes longer to exhaust lock release air and may cause locking delay. Due to the delay, the increase of overrun for intermediate stop or emergency stop in the middle of operation can result. In applications of holding as drop prevention, due to the locking delay, the work piece may fall temporarily depending on the timing of the load.

- ③ **Back flow of the exhaust pressure from the common exhaust type valve manifold is not allowed.**

If exhaust pressure for lock release flows backwards, locking may not be performed correctly. Use an individual exhaust type manifold or single unit valve.

- ④ **Time between locking and lock release shall be 0.5 seconds or longer.**

If locking time is short, the piston rod and the workload will shoot out faster than the speed controlled by speed controller.

- ⑤ **Control the switching operation of the lock release solenoid valve during restart of the cylinder so that the lock release solenoid valve is switched before the cylinder actuating solenoid valve or both switched at the same time.**

If locking time is short, the piston rod and the workload will shoot out faster than the speed controlled by the speed controller.

- ⑥ **Be aware that repeated supply and exhaust of the solenoid valve for lock may cause condensation.**

The lock unit operating stroke is very small and so the pipe is long. If supplying and exhausting air repeatedly, condensation which occurs by adiabatic expansion, accumulates in the lock unit. This may cause air leakage and an unlocking malfunction due to corrosion of internal parts.

- ⑦ **Basic Circuit**

1. [Horizontal]

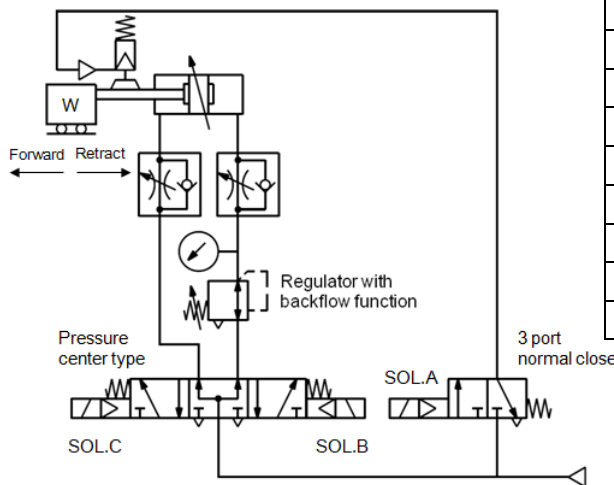

SOL.A	SOL.B	SOL.C	Operation
ON	ON	OFF	Forward
OFF	OFF	OFF	Lock
ON	OFF	OFF	Unlock
ON	ON	OFF	Forward
ON	OFF	ON	Retract
OFF	OFF	OFF	Lock
ON	OFF	OFF	Unlock
ON	OFF	ON	Retract

0.5S or longer

0.5S or longer

2. [Vertical]

[Load applied in extending direction of the rod]

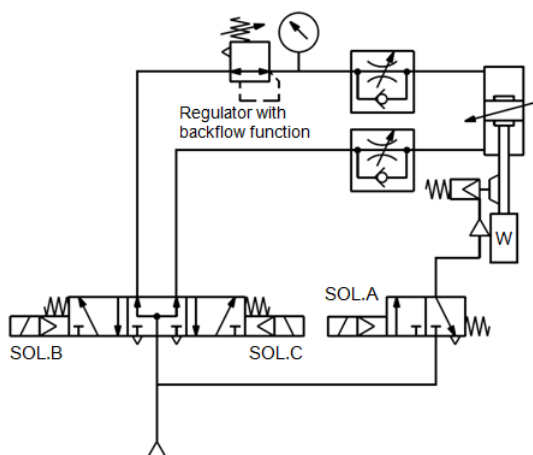

[Load applied in retracting direction of the rod]

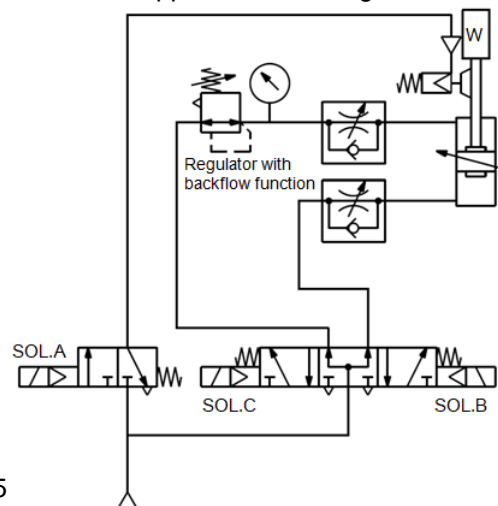



**Caution**

- ① One 3-position pressure center solenoid valve and a regulator with check valve can be replaced by 2 3-port normally open valves and a regulator with a relief valve.

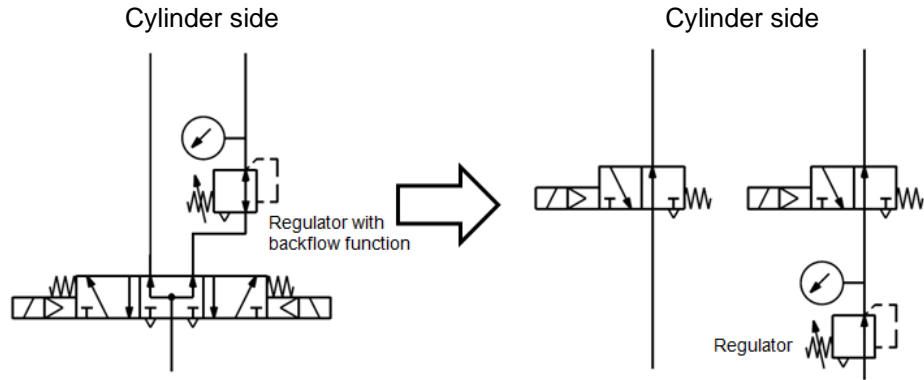

1. [Horizontal]

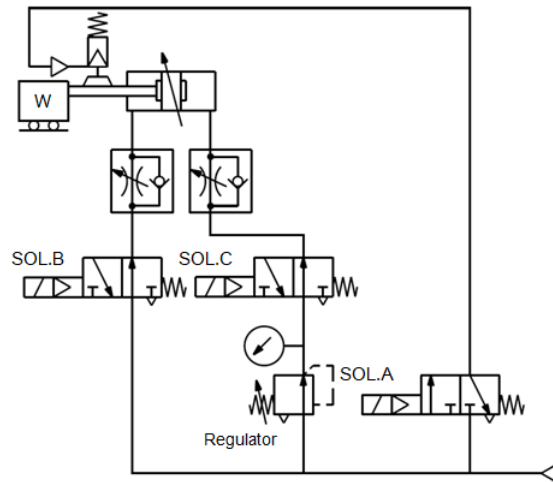

2. [Vertical]

[Load applied in extending direction of the rod]

[Load applied in retracting direction of the rod]

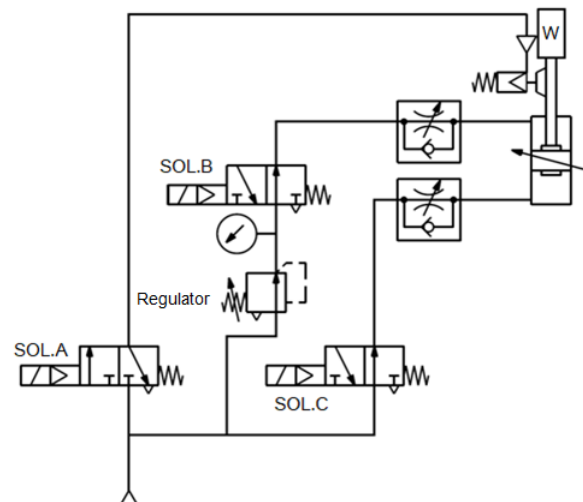
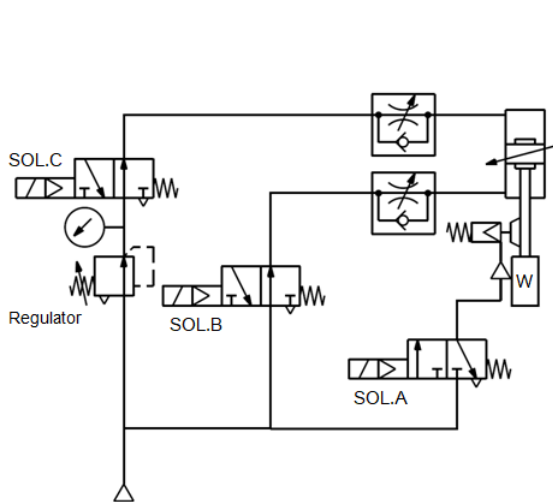

**2-9. Adjustment and Operation**

**Caution**

- ① Adjust the air balance of the cylinder. Adjust the air pressure of the cylinder rod side and head side with the cylinder (with load) unlocked. With balanced air, the cylinder will not shoot out when unlocked.
- ② Adjust the position for detection part of auto switch, etc. For intermediate stop, adjust the auto switch detection position, taking the overrun into consideration.

### 3. How to Use

#### 3-1. Usage

① **For intermediate stop, take stopping accuracy and overrun into consideration.**

As this is a mechanical lock, there will be a slight time difference for the stop signal and delay of the cylinder. The cylinder stroke during the delay is called overrun. The range between maximum and minimum overrun is referred to as overrun. The relation is shown below.

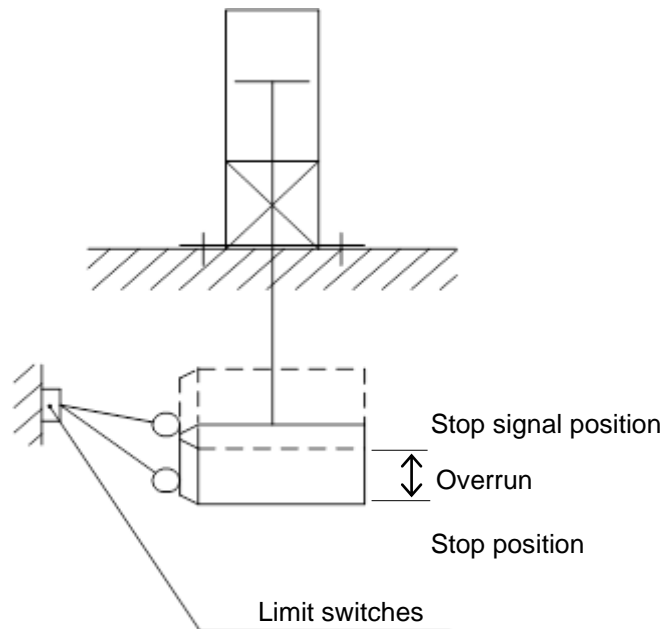

**Fig. 5 Overrun of intermediate stop**

- a. It is necessary to place the limit switch taking account the amount of overrun to achieve the desired stop position.
- b. The length of the limit switch needs to be overrun +  $\alpha$  for detection (switch detector length).
- c. Operation range of standard auto switch of SMC is 8 to 14mm (It depends on switch types and cylinder bore sizes.) When overrun exceeds that range, self-holding of contact should be performed at the switch load side.

② **In order to reduce overrun and improve the stop accuracy, reduce the time between the generation of the stop signal and stopping by locking as short as possible.**

- a. Use an electric circuit for control and solenoid valve with high response.
- b. Keep the lock release solenoid valve and lock release port as close as possible.
- c. If b is difficult, install a rapid exhaust valve between the lock release solenoid valve and lock release port.

③ **Piston speed affects the stopping accuracy most.**

- a. Piston speed has to be stable before the stop position. If the piston speed varies due to the change of load or interference the stop position will vary.
- b. During cushioning or acceleration of the operation start, the variation of stop position is high (as the change in speed is high).

### 3-2. Lock release mechanism

Operation principle for unlocking mechanism.

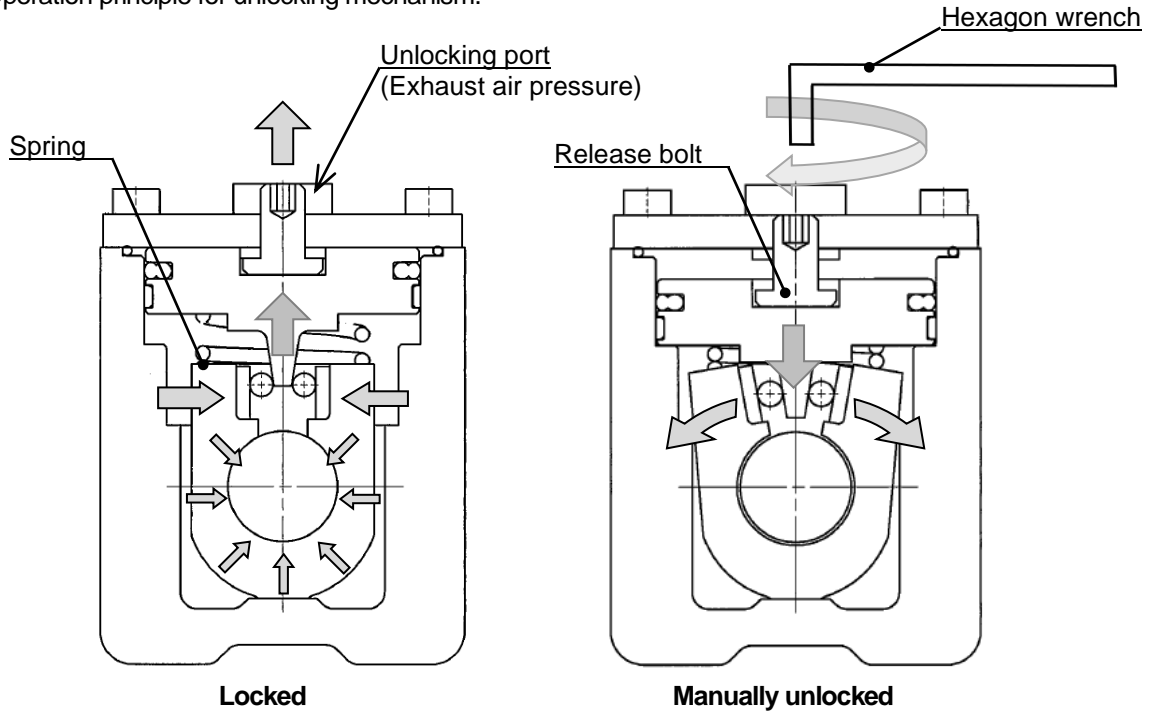
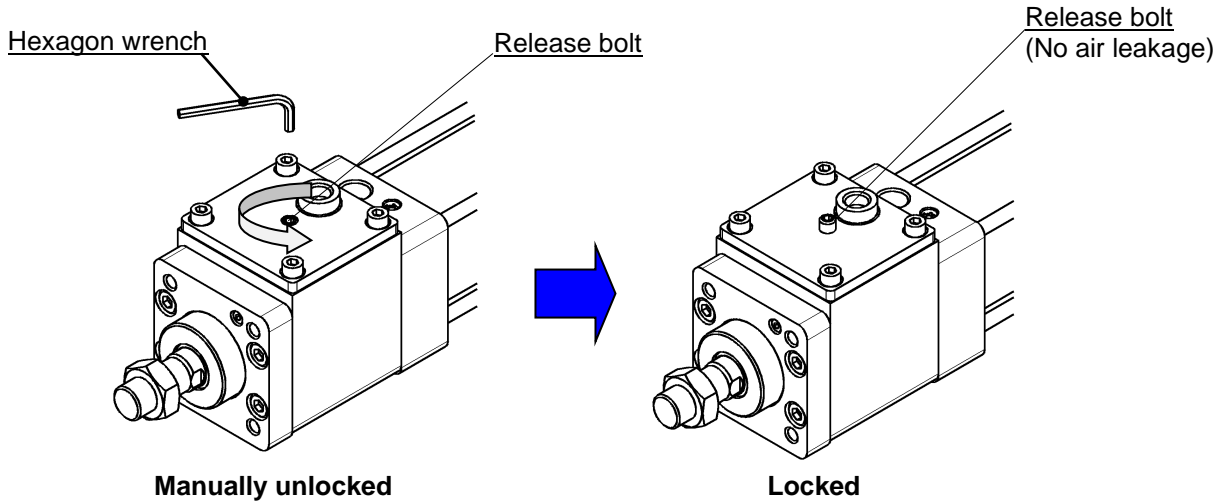

**Fig.6 Operation principle of locking mechanism**

(Fig. 6 is for reference for the operation principle. (Different from the actual structure))

#### **Warning**

The manual lock is released as default. The lock will not operate in this condition. Before starting operation engage the lock according to the instructions shown in Fig. 7.



**Fig.7 How to return to lock**

Rotate the release bolt anti-clockwise by hand with a hexagon wrench until resistance is felt. Once that position is reached, rotate it an additional 1/6th of a turn to securely tighten the release bolt.

\*) Please do not use an electric driver or pneumatic driver.

Pressurize the lock release port with 0.3MPa or more of air pressure and check that there is no air leakage from the release bolt and lock correctly functions. Unlocked condition can be held in reversed order of Fig. 7.

Tube I. D.	Hexagon wrench size of the release bolt
32·40	3
40·50	4
80·100	5

 **Warning**

**(1) Do not operate the release bolt until safety is confirmed. Do not twist**

- a) If only one side of the cylinder is pressurized during unlocking, the moving part of the cylinder may extend suddenly which can be very dangerous
- b) Carefully confirm that personnel are not within the moving range of the load and there is no danger, even if the load moves suddenly.

**(2) Exhaust all residual pressure in the system before rotating the release bolt. Do not apply pressure to the lock release port when manually unlocked.**

**(3) Take action to prevent the load from falling when unlocked.**

- a) Place the load at the end of the downward stroke.
- b) Place guides, etc. to stop the load from falling.
- c) Confirm that pressure of both ends of the piston is balanced.

 **Caution**

**When releasing the locked state with the release bolt for the purpose of mounting or adjustment, be sure to return the release bolt to the locked state.**

**If the release bolt is not returned to the locked state, the lock might not function correctly or lock release might not be completed due to air leakage from the release bolt.**

### 3-3. Auto switch

When an auto switch is mounted or its set position is changed, refer to Fig. 8 to 13.

#### Caution

- Use a specific mounting bracket on page 26.
- Tighten the auto switch mounting screws with an appropriate torque.
- The auto switch can be used for cylinder with a built-in magnet for auto switch (e.g. MDWB) only.
- Mounting switch is limited depending on the stroke. (P.29~32)

< Applicable Auto switches >

Solid state switch..... D-M9N(V)·M9P(V)·M9B(V)  
D-M9NW(V)·M9PW(V)·M9BW(V)  
D-M9NA(V)·M9PA(V)·M9BA(V)  
Reed switch ..... D-A90(V)·A93(V)·A96(V)

#### How to mount and move the auto switch

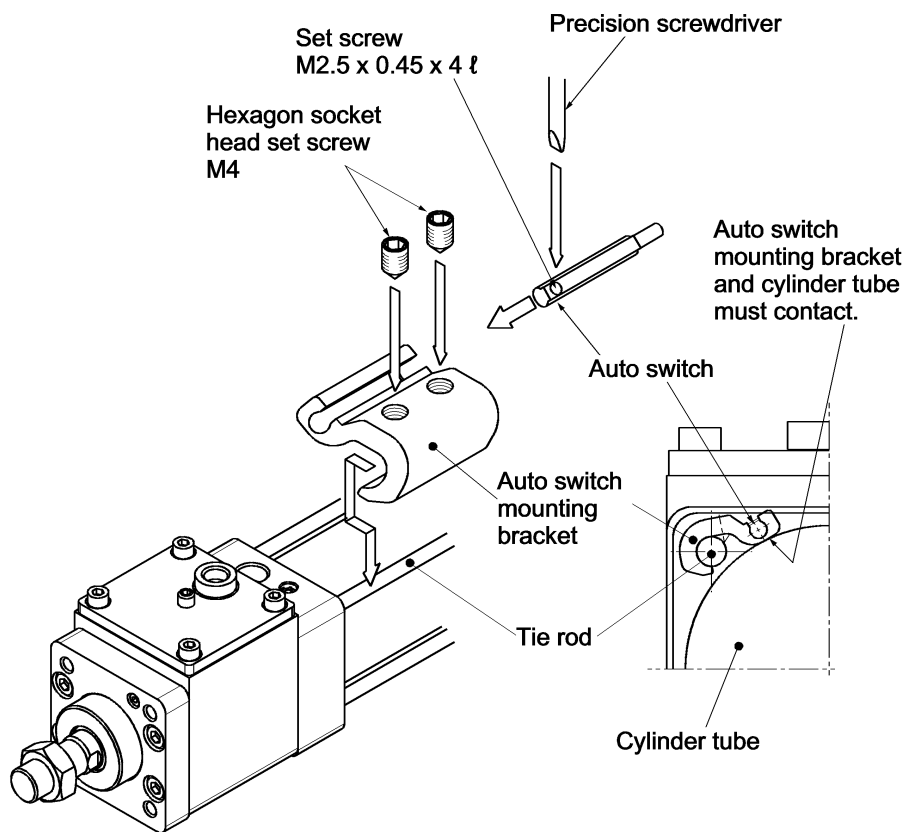

Fig. 8

- ① Attach the auto switch mounting bracket to the cylinder tie rod so that the bottom surface of the auto switch mounting bracket contacts the cylinder tube.
- ② Fix the auto switch mounting bracket to the detection position using the set screws (M4 x 2). (Use hexagon wrench)
- ③ Insert the auto switch to the auto switch mounting groove of the bracket to set the bracket to the approximate position for the switch.
- ④ After checking the detecting position, tighten the mounting screw (M2.5) to secure the auto switch.
- ⑤ The detection position can be changed under the conditions in step ③.

Note 1) To protect the auto switch, mount the auto switch with the switch body mounted entirely in the auto switch mounting groove for more than 15mm.

Note 2) The tightening torque of the M4 screw must be 1 to 1.2Nm.

Note 3) For the tightening of the mounting screws (M2.5), use a precision screwdriver with a handle diameter of approximately 5 to 6 mm. The tightening torque should be approximately 0.05 to 0.15Nm.

As a guideline, turn 90° from the position where the mounting screw starts to become tight.

< Applicable Auto switches >

Solid state switch..... D-F59•F5P

D-J59•J51•F5BAL

D-F59W•F5PW•J59W

D-F59F•F5NTL

Reed switch ..... D-A53•A54•A56•A64•A67

D-A59W

How to mount and move the auto switch

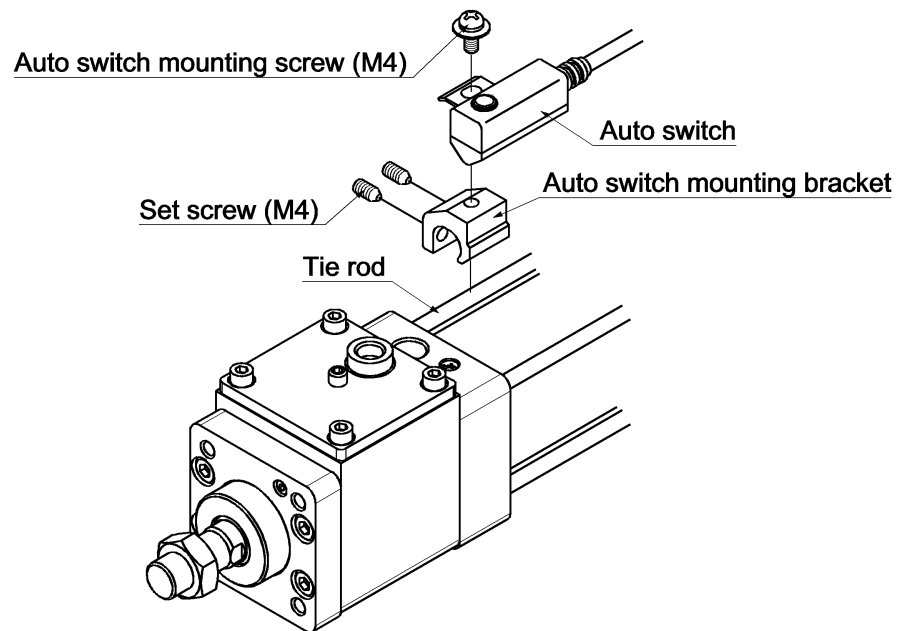

**Fig. 9**

- ① Fix the auto switch to the auto switch mounting bracket using auto switch mounting screw (M4). Then, set the set screws (M4 x 2).
- ② Attach the auto switch mounting bracket to the cylinder tie rod so that the bottom surface of the auto switch contacts the cylinder tube. Then, fix the auto switch mounting bracket at the detection position using the set screws. (Use hexagon wrench)
- ③ In order to change the detection position, loosen the set screws to move the auto switch, and then, fix the auto switch mounting bracket at the detection position using the set screws so that the bottom surface of the auto switch contacts the cylinder tube. (The tightening torque of the M4 screw must be 1 to 1.2Nm.)

< Applicable Auto switches >

Solid state switch.....D-Y59A/B·Y69A/B·Y7P(V)  
D-Y7NW(V)·Y7PW(V)·Y7BW(V)  
D-Y7BAL  
Reed switch .....D-Z73·Z76·Z80

How to mount and move the auto switch

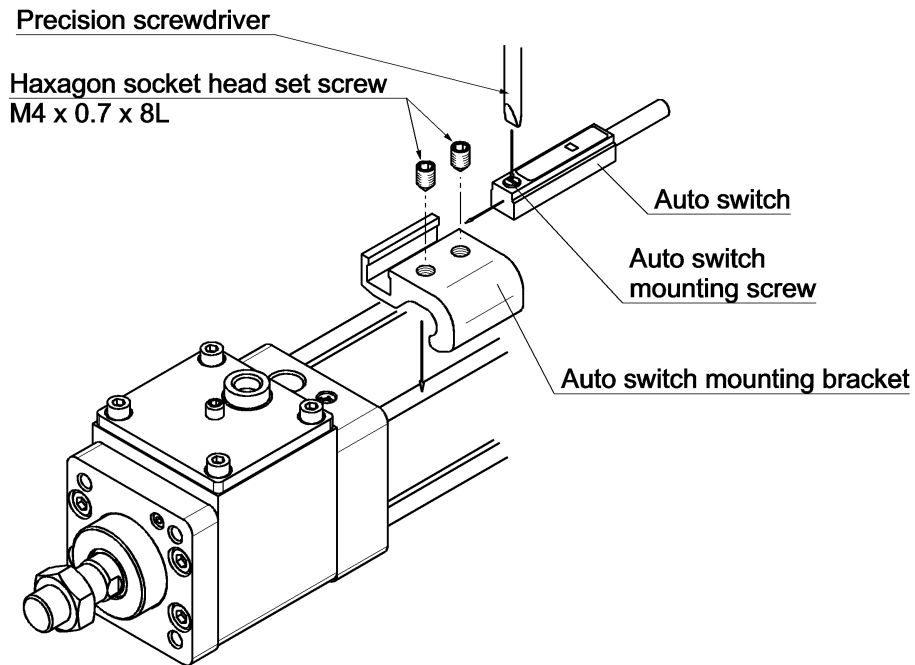

**Fig. 10**

- ① Attach the auto switch mounting bracket to the cylinder tie rod so that the bottom surface of the auto switch mounting bracket contacts the cylinder tube. Then, fix the auto switch mounting bracket at the detection position using the set screws. (Use hexagon wrench)
- ② Insert the auto switch to the auto switch mounting groove of the bracket to set the bracket to the approximate position for the switch.
- ③ After checking the detecting position, tighten the mounting screw (M2.5) to fix the auto switch.
- ④ The detection position can be changed under the conditions in step ②.

Note 1) To protect the auto switch, mount the auto switch with the switch body mounted entirely in the auto switch mounting groove for more than 15mm.

Note 2) When tightening the auto switch mounting screw, use a precision screwdriver with a handle of 5 to 6 mm in diameter. Use the tightening torque of approximately 0.05 to 0.1 Nm. As a guideline, turn 90° from the position where the mounting screw starts to become tight. Tightening torque of the hexagon socket head set screw (M4 x 0.7) shall be 1 to 1.2Nm.

< Applicable Auto switches >  
 Solid state switch..... D-P3DWA

How to mount and move the auto switch

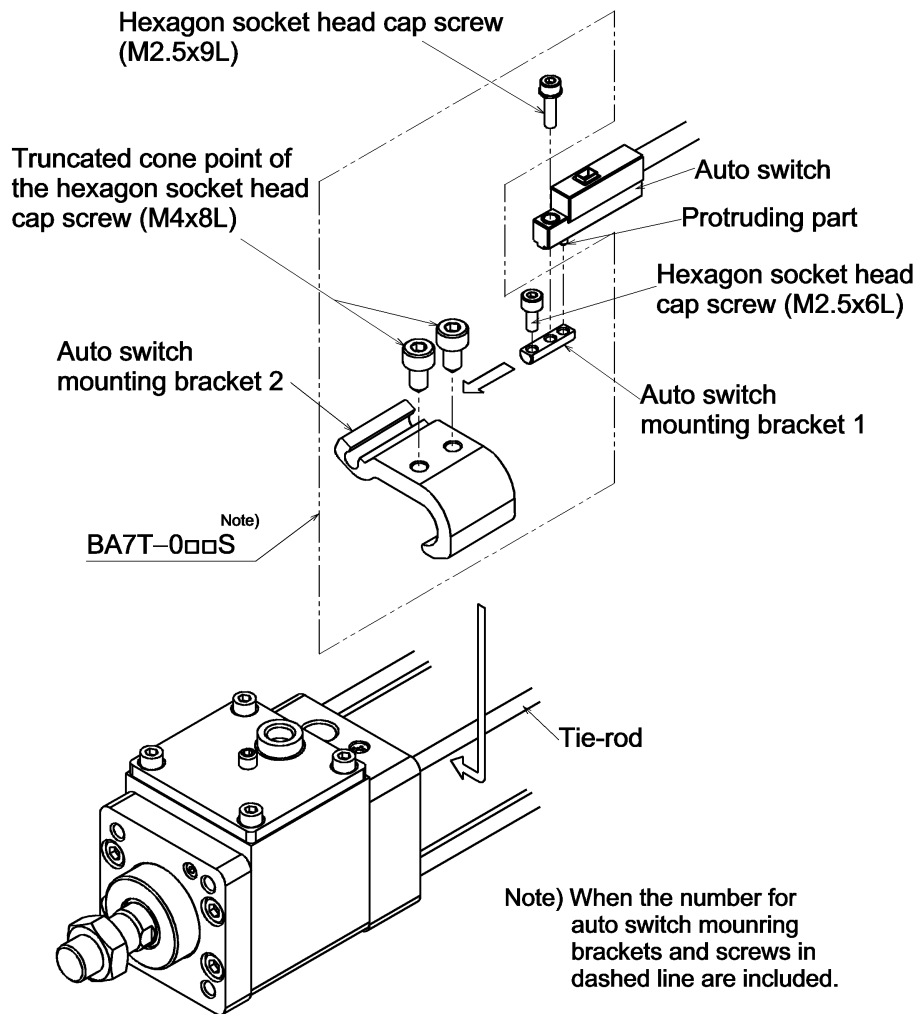

Fig. 11

- ① Mount the auto switch mounting bracket 2 to the tie rod. Fix the truncated cone point of the hexagon socket head cap screws (M4 x 8L) so that bottom surface of the auto switch mounting bracket contacts the cylinder tube.
- ② Insert the protruding part at the back of the auto switch to the receiving part of the auto switch mounting bracket 1. Turn the hexagon socket head cap screw (M2.5 x 9.5L) for 1 or 2 rotations, and hold the auto switch to the auto switch mounting bracket temporarily.
- ③ Insert the auto switch mounting bracket 1 to the groove of the auto switch mounting bracket 2. Check that the detection position is correct, then tighten the hexagon socket head cap screws (M2.5x6L and M2.5x9.5L) to hold the auto switch in place.
- ④ The detection position can be changed under the conditions in step ① or ③.

Note1) To protect the auto switch, mount the auto switch with the switch body mounted entirely in the auto switch mounting groove for more than 15mm.

Note 2) When tightening the truncated cone point of the hexagon socket head cap screws (M4 x 8L), use tightening torque of 1 to 1.2Nm.

Note 3) When tightening the hexagon socket head cap screws (M2.5 x 6L, M2.5x9.5L), use tightening torque of 0.2 to 0.3Nm.

Note 4) Tighten the hexagon socket head cap screws evenly.

Note 5) D-P3DWA cannot be mounted on bore size Ø32.



< Applicable Auto switches >  
Solid state switch..... D-P4DWL

How to mount and move the auto switch

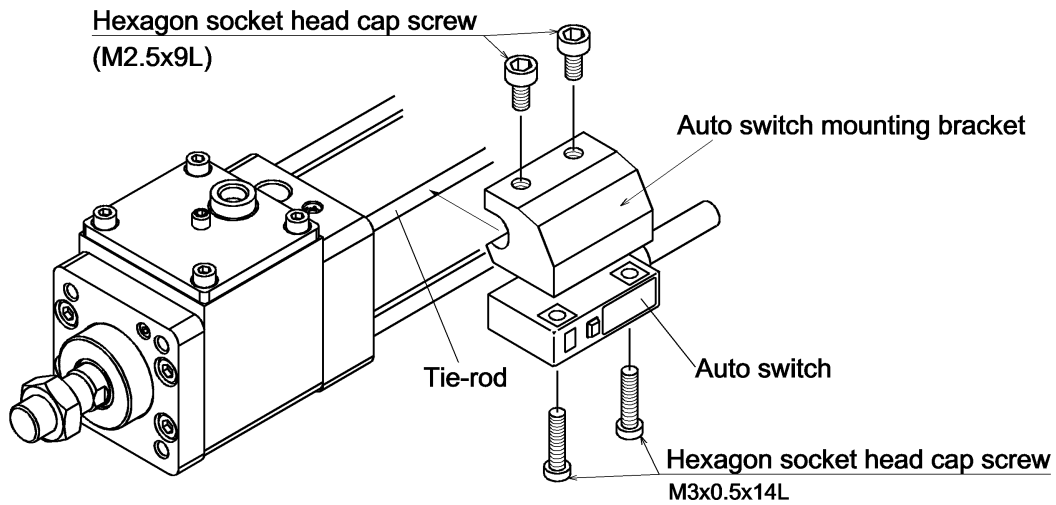

Fig. 12

- ① Put M4x0.7x8L (2pcs.) into the tapped part for M4 on the auto switch mounting bracket and turn them lightly into the tapped holes. Make sure that the end of the hexagon socket head cap screw does not come out of the recessed part of the auto switch mounting bracket.
- ② Put M3x0.5x14L (2pcs.) into the tapped part for M3 on the auto switch mounting bracket and turn them lightly into the tapped holes.
- ③ Attach the recessed part of the auto switch mounting bracket to the cylinder tie rod, and set to the approximate detection position by sliding the auto switch mounting bracket.
- ④ After checking the detection position, tighten M3 screws to fix the auto switch so that the bottom of the auto switch contact the cylinder tube. (The tightening torque of the M3 screw must be 0.5 to 0.7Nm.)
- ⑤ Tighten the auto switch mounting screw(M4) to fix the auto switch mounting bracket. (The tightening torque of the M4 screw must be 1.0 to 1.2Nm.)

< Applicable Auto switches >

Solid state switch..... D-G39•K39

Reed switch ..... D-A33•A34•A44

How to mount and move the auto switch

**D-A3, D-G3•K3**

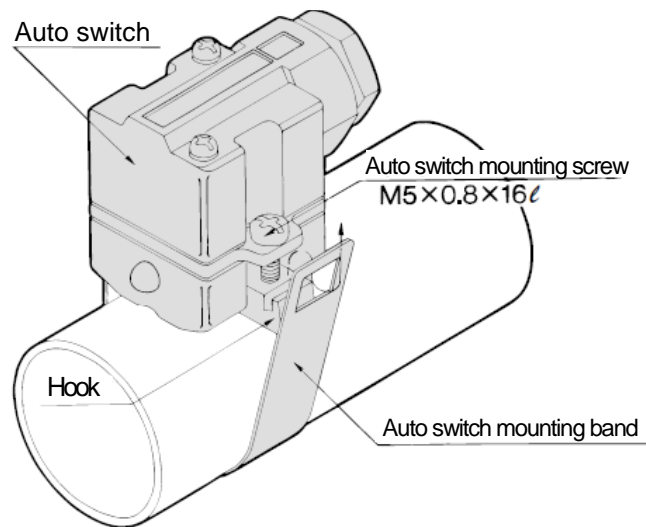

**D-A44**

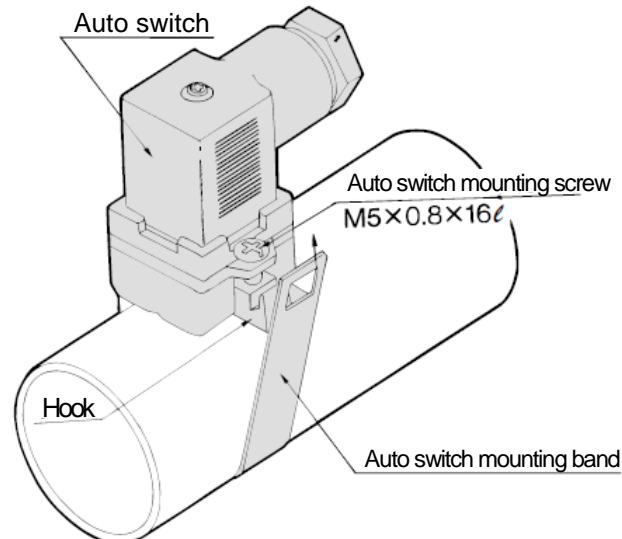

**Fig. 13**

- ① Loosen the auto switch mounting bracket (hook) screw (x 2) to lower the hook.
- ② Set the mounting band for the auto switch roughly at the auto switch set position of the cylinder tube, and connect the band on to the hook.
- ③ Turn the auto switch mounting screw slightly.
- ④ Confirm where the detecting position is, and tighten the mounting screw to fix the auto switch. (The tightening torque must be 2 to 3Nm.)
- ⑤ The detection position can be changed under the conditions in step ③.

## Auto switch mounting brackets/ Part No.

Auto switch model	Bore size (mm)					
	Ø32	Ø40	Ø50	Ø63	Ø80	Ø100
D-M9□/ M9□V D-M9□W/ M9□WV D-M9□A/ M9□AV D-A9□/ A9□V	BMB5-032	BMB5-032	BA7-040	BA7-040	BA7-063	BA7-063
D-A3□/ A44 D-G39/ K39	BMB2-032	BMB2-040	BMB1-050	BMB1-063	BMB1-080	BMB1-100
D-F5□/ J59 D-F5□W/ J59W D-F59F/ F5BA D-F5NT D-A5□/ A6□/ A59W	BT-03	BT-03	BT-05	BT-05	BT-06	BT-06
D-P3DWA	BA10-032S	BA10-040S	BA10-050S	BA10-050S	BA10-063S	BA10-063S
D-P4DW	BMB3T-040	BMB3T-040	BMB3T-050	BMB3T-050	BMB3T-080	BMB3T-080
D-Y59□/ Y69□ D-Y7P/ Y7PV D-Y7□W/ Y7□WV D-Y7BA D-Z7□/ Z80	BMB4-032	BMB4-032	BMB4-050	BMB4-050	BMB4-063	BMB4-063

### [Stainless steel mounting screw]

The following stainless steel mounting screw kit (including set screws) is available. Use it in accordance with the operating environment. (Since the auto switch mounting bracket is not included, order it separately.)

BBA1: For D-A5/ A6/ F5/ J5 types

\* Refer to the Web Catalog or Best Pneumatics for details on the BBA1.

The above stainless steel screws are used when a cylinder is shipped with the D-F5BA auto switch. When only one auto switch is shipped independently, the BBA1 is attached.

\* When using the D-M9□A(V) or Y7BA, do not use the steel set screws which are included with the auto switch mounting brackets above (BMB5-032, BA7-□□□, BMB4-□□□, BA4-□□□).

Order a stainless steel screw kit (BBA1) separately, and use the M4 x 6L stainless steel set screws included in the BBA1.

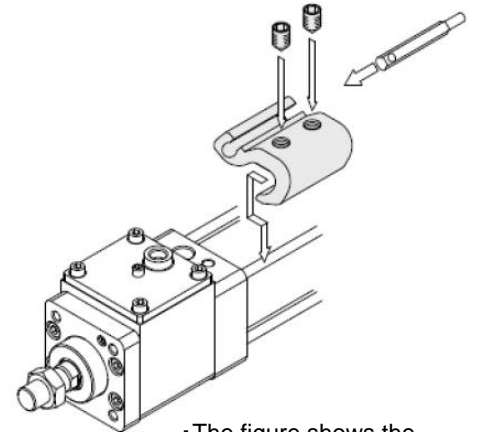

• The figure shows the mounting example for the D-M9□(V)/ M9□W(V)/ M9□A(V)/ A9□(V)

### Operating Range

Auto switch model	Bore size (mm)					
	Ø32	Ø40	Ø50	Ø63	Ø80	Ø100
D-M9□/ M9□V D-M9□W/ M9□WV D-M9□A/ M9□AV	4	4.5	4.5	4.5	5	6
D-Y59□/ Y69□ D-Y7P/ Y7PV D-Y7□W/ Y7□WV D-Y7BA	5.5	5.5	7	7.5	6.5	5.5
D-F5□/ J59 D-F5□W/ J59W D-F5BA/ F5NT D-F59F	3.5	4	4	4.5	4.5	4.5
D-G39/ K39	9	9	9	10	10	11
D-P3DWA	3	4.5	4.5	5	5	5.5
D-P4DW	4	4	4	4.5	4	4.5
D-A9□/ A9□V	7	7.5	8.5	9.5	9.5	10.5
D-Z7□/ Z80	7.5	8.5	7.5	9.5	9.5	10.5
D-A5□/ A6□	9	9	10	11	11	11
D-A59W	13	13	13	14	14	15
D-A3□/ A44	9	9	10	11	11	11

\* Values which include hysteresis are for guideline purposes only, they are not a

### <Mounting example for Ø32, D-P3DWA>

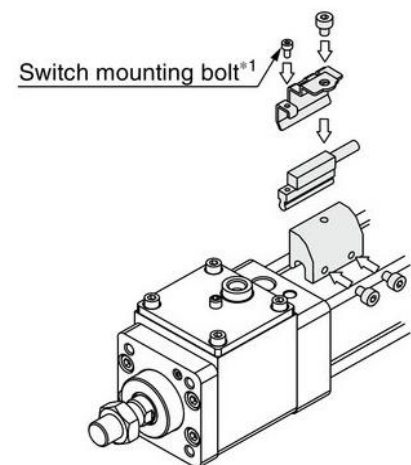

\*1 The switch mounting bolt is supplied with the switch.

# Auto Switch Proper Mounting Position (Detection at stroke end) and Mounting Height

## <Tie-rod mounting>

D-M9□/M9□V型      D-Y59□/Y69□/Y7P/Y7PV型  
 D-M9□W/M9□WV型      D-Y7□W/Y7□WV/Y7BA型  
 D-M9□A/M9□AV型      D-Z7□/Z80型  
 D-A9□/A9□V型

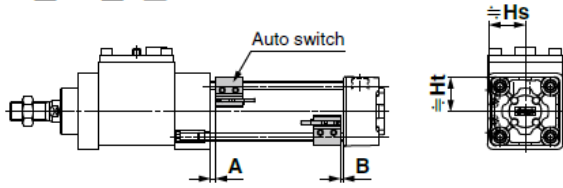

D-A5□/A6□型  
 D-A59W型

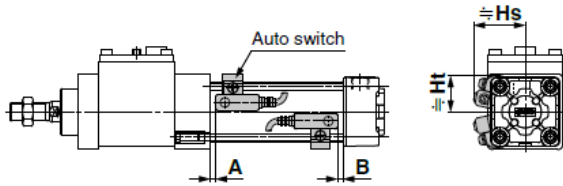

D-F5□/J5□型  
 D-F5□W/J59W/F5BA型  
 D-F59F/F5NT型

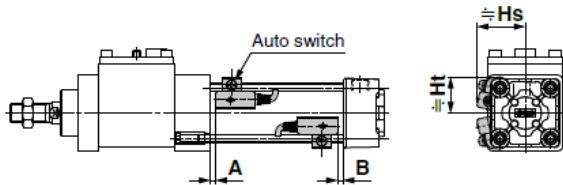

D-P3DWA型

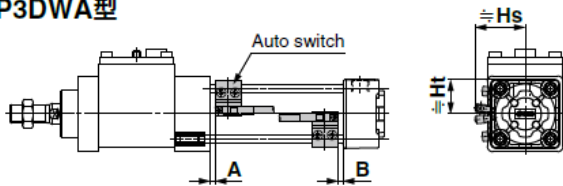

D-P4DW型

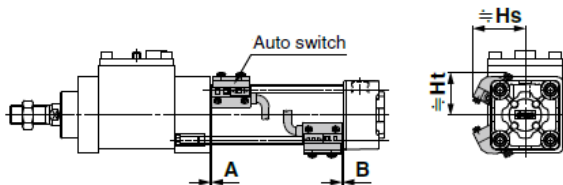

## <Band mounting>

D-G39/K39/A3□型

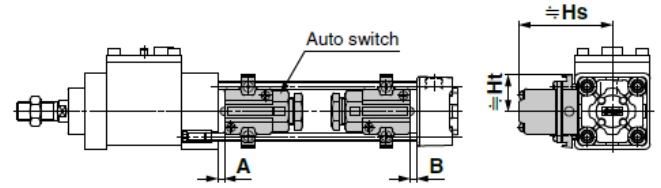

D-A44型

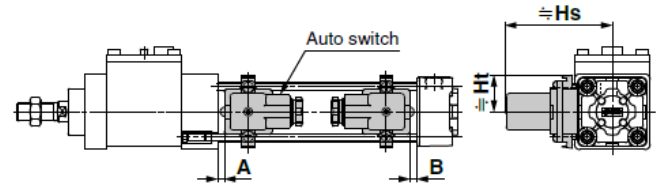

## Auto switch proper mounting position (detection at stroke end) and its mounting height

### Auto Switch Proper Mounting Position

[mm]

Auto switch model	D-M9□ D-M9□V D-M9□W D-M9□WV D-M9□A D-M9□AV		D-A9□ D-A9□V		D-F5□ D-J59 D-F59F		D-F5NT		D-A5□ D-A6□		D-A59W		D-G39 D-K39 D-A3□ D-A44		D-Y59□ D-Y69□ D-Y7P D-Y7PV D-Y7H D-Y7□W D-Y7□WV D-Z7□ D-Z8□		D-P3DWA		D-P4DW	
	A	B	A	B	A	B	A	B	A	B	A	B	A	B	A	B	A	B	A	B
32	10	8	6	4	6.5	4.5	11.5	9.5	0	0	4	2	0	0	3.5	1.5	5.5	3.5	3	1
40	9	9	5	5	5.5	5.5	10.5	10.5	0	0	3	3	0	0	2.5	2.5	4.5	4.5	2	2
50	10	9	6	5	6.5	5.5	11.5	10.5	0	0	4	3	0	0	3.5	2.5	5.5	4.5	3	2
63	10	9	6	5	6.5	5.5	11.5	10.5	0	0	4	3	0	0	3.5	2.5	5.5	4.5	3	2
80	14.5	11.5	10.5	7.5	11	8	16	13	4.5	1.5	8.5	5.5	4.5	1.5	8	5	10	7	7.5	4.5
100	14	12	10	8	10.5	8.5	15.5	13.5	4	2	8	6	4	2	7.5	5.5	9.5	7.5	7	5

\*Models with rubber bumper have different dimensions for auto switch proper mounting positions (A to B). Add the following values to both A and B: 3mm (Ø32 and Ø40), 4mm (Ø50 and Ø63), 5mm (Ø80 and Ø100).

Note) Adjust the auto switch after confirming the operating conditions in the actual setting.

### Auto Switch Mounting Height

[mm]

Auto switch model	D-M9□ D-M9□W D-M9□A D-A9□		D-A9□V		D-M9□V D-M9□WV D-M9□AV		D-F5□ D-J59 D-F59F D-F5□W D-J59W D-F5BA D-F5NT		D-A5□ D-A6□ D-A59W		D-G39 D-K39 D-A3□		D-A44		D-Y59□ D-Y7P D-Y7□W D-Y7BA D-Z7□ D-Z8□		D-Y69□ D-Y7PV D-Y7□WV		D-P3DWA		D-P4DW	
	Hs	Ht	Hs	Ht	Hs	Ht	Hs	Ht	Hs	Ht	Hs	Ht	Hs	Ht	Hs	Ht	Hs	Ht	Hs	Ht	Hs	Ht
32	24.5	23	27.5	23	30.5	23	32.5	25	35	24.5	67	27.5	77	27.5	25.5	23	26.5	23	38	31	38	31
40	28.5	25.5	31.5	25.5	34	25.5	36.5	27.5	38.5	27.5	71.5	27.5	81.5	27.5	29.5	26	30	26	39	25.5	42	33
50	33.5	31	36	31	38.5	31	41	34	43.5	34.5	77	—	87	—	33.5	31	34.5	31	43	31	46.5	39
63	38.5	36	40.5	36	43	36	46	39	48.5	39.5	83.5	—	93.5	—	39	36	40	36	48	36	51.5	44
80	46.5	45	49	45	52	45	52.5	46.5	55	46.5	92.5	—	103	—	47.5	45	48.5	45	56.5	45	58	51.5
100	54	53.5	57	53.5	59.5	53.5	59.5	55	62	55	103	—	113.5	—	55.5	53.5	56.5	53.5	64.5	53.5	65.5	60.5

# Minimum Stroke for Auto Switch Mounting

## Mounting Brackets except Center Trunnion

n: Number of auto switches [mm]

Auto switch model	Number of auto switches	ø32, ø40, ø50, ø63	ø80, ø100
D-M9□ D-M9□W	2 (Different surfaces, same surface) 1	15	
	n	$15+40\frac{(n-2)}{2}$ (n=2, 4, 6, 8...)*1	
D-M9□V D-M9□WV	2 (Different surfaces, same surface) 1	10	
	n	$10+30\frac{(n-2)}{2}$ (n=2, 4, 6, 8...)*1	
D-M9□A	2 (Different surfaces, same surface) 1	15	
	n	$15+40\frac{(n-2)}{2}$ (n=2, 4, 6, 8...)*1	
D-M9□AV	2 (Different surfaces, same surface) 1	15	
	n	$15+30\frac{(n-2)}{2}$ (n=2, 4, 6, 8...)*1	
D-A9□	2 (Different surfaces, same surface) 1	15	
	n	$15+40\frac{(n-2)}{2}$ (n=2, 4, 6, 8...)*1	
D-A9□V	2 (Different surfaces, same surface) 1	10	
	n	$10+30\frac{(n-2)}{2}$ (n=2, 4, 6, 8...)*1	
D-G39 D-K39 D-A3□	2 (Different surfaces)	35	
	2 (Same surface)	100	
	n (Different surfaces)	$35+30(n-2)$ (n=2, 3, 4...)	
	n (Same surface)	$100+100(n-2)$ (n=2, 3, 4...)	
	1	10	
D-A44	2 (Different surfaces)	35	
	2 (Same surface)	55	
	n (Different surfaces)	$35+30(n-2)$ (n=2, 3, 4...)	
	n (Same surface)	$55+50(n-2)$ (n=2, 3, 4...)	
	1	10	
D-F5□ D-J59 D-F5□W D-J59W D-F5BA D-F59F	2 (Different surfaces)	15	25
	n (Same surface)	$15+55\frac{(n-2)}{2}$ (n=2, 4, 6, 8...)*1	$25+55\frac{(n-2)}{2}$ (n=2, 4, 6, 8...)*1
	1	10	25
D-A5□ D-A6□	2 (Different surfaces, same surface) 1	15	20
	n (Same surface)	$15+55\frac{(n-2)}{2}$ (n=2, 4, 6, 8...)*1	$20+55\frac{(n-2)}{2}$ (n=2, 4, 6, 8...)*1
D-A59W	2 (Different surfaces, same surface)	20	25
	n (Same surface)	$20+55\frac{(n-2)}{2}$ (n=2, 4, 6, 8...)*1	$25+55\frac{(n-2)}{2}$ (n=2, 4, 6, 8...)*1
	1	15	25
D-F5NT	2 (Different surfaces, same surface)	15	25
	n (Same surface)	$15+55\frac{(n-2)}{2}$ (n=2, 4, 6, 8...)*1	$25+55\frac{(n-2)}{2}$ (n=2, 4, 6, 8...)*1
	1	10	25
D-Y59□ D-Y7P D-Y7□W D-Z7□ D-Z80	2 (Different surfaces, same surface) 1	15	
	n	$15+40\frac{(n-2)}{2}$ (n=2, 4, 6, 8...)*1	

\*1 When "n" is an odd number, an even number that is one larger than the odd number is to be used for the calculation.

## Minimum Stroke for Auto Switch Mounting

### Mounting Brackets except Center Trunnion

n: Number of auto switches [mm]

Auto switch model	Number of auto switches	ø32, ø40, ø50, ø63, ø80, ø100
D-Y69□ D-Y7PV D-Y7□WV	2 (Different surfaces, same surface)	10
	n	$10 + 30 \frac{(n-2)}{2}$ (n = 2, 4, 6, 8...)*1
D-Y7BA	2 (Different surfaces, same surface)	20
	n	$20 + 45 \frac{(n-2)}{2}$ (n = 2, 4, 6, 8...)*1
D-P3DWA	2 (Different surfaces, same surface)	15
	n	$15 + 50 \frac{(n-2)}{2}$ (n = 2, 4, 6, 8...)*1
D-P4DW	2 (Different surfaces, same surface)	15
	n	$15 + 65 \frac{(n-2)}{2}$ (n = 2, 4, 6, 8...)*1

\*1 When "n" is an odd number, an even number that is one larger than the odd number is to be used for the calculation.

### Center Trunnion

n: Number of auto switches [mm]

Auto switch model	Number of auto switches	ø32	ø40	ø50	ø63	ø80	ø100
D-M9□ D-M9□W	2 (Different surfaces, same surface)	75	80	85	90	95	
	n	$75 + 40 \frac{(n-4)}{2}$ (n = 4, 8, 12, 16...)*2	$80 + 40 \frac{(n-4)}{2}$ (n = 4, 8, 12, 16...)*2	$85 + 40 \frac{(n-4)}{2}$ (n = 4, 8, 12, 16...)*2	$90 + 40 \frac{(n-4)}{2}$ (n = 4, 8, 12, 16...)*2	$95 + 40 \frac{(n-4)}{2}$ (n = 4, 8, 12, 16...)*2	
D-M9□V D-M9□WV	2 (Different surfaces, same surface)	50	55	60	65	70	
	n	$50 + 30 \frac{(n-4)}{2}$ (n = 4, 8, 12, 16...)*2	$55 + 30 \frac{(n-4)}{2}$ (n = 4, 8, 12, 16...)*2	$60 + 30 \frac{(n-4)}{2}$ (n = 4, 8, 12, 16...)*2	$65 + 30 \frac{(n-4)}{2}$ (n = 4, 8, 12, 16...)*2	$70 + 30 \frac{(n-4)}{2}$ (n = 4, 8, 12, 16...)*2	
D-M9□A	2 (Different surfaces, same surface)	80	85	90	95	100	
	n	$80 + 40 \frac{(n-4)}{2}$ (n = 4, 8, 12, 16...)*2	$85 + 40 \frac{(n-4)}{2}$ (n = 4, 8, 12, 16...)*2	$90 + 40 \frac{(n-4)}{2}$ (n = 4, 8, 12, 16...)*2	$95 + 40 \frac{(n-4)}{2}$ (n = 4, 8, 12, 16...)*2	$100 + 40 \frac{(n-4)}{2}$ (n = 4, 8, 12, 16...)*2	
D-M9□AV	2 (Different surfaces, same surface)	55	60	65	70	75	
	n	$55 + 30 \frac{(n-4)}{2}$ (n = 4, 8, 12, 16...)*2	$60 + 30 \frac{(n-4)}{2}$ (n = 4, 8, 12, 16...)*2	$65 + 30 \frac{(n-4)}{2}$ (n = 4, 8, 12, 16...)*2	$70 + 30 \frac{(n-4)}{2}$ (n = 4, 8, 12, 16...)*2	$75 + 30 \frac{(n-4)}{2}$ (n = 4, 8, 12, 16...)*2	
D-A9□	2 (Different surfaces, same surface)	70	75	80	85	95	
	n	$70 + 40 \frac{(n-4)}{2}$ (n = 4, 8, 12, 16...)*2	$75 + 40 \frac{(n-4)}{2}$ (n = 4, 8, 12, 16...)*2	$80 + 40 \frac{(n-4)}{2}$ (n = 4, 8, 12, 16...)*2	$85 + 40 \frac{(n-4)}{2}$ (n = 4, 8, 12, 16...)*2	$95 + 40 \frac{(n-4)}{2}$ (n = 4, 8, 12, 16...)*2	
D-A9□V	2 (Different surfaces, same surface)	45	50	55	60	70	
	n	$45 + 30 \frac{(n-4)}{2}$ (n = 4, 8, 12, 16...)*2	$50 + 30 \frac{(n-4)}{2}$ (n = 4, 8, 12, 16...)*2	$55 + 30 \frac{(n-4)}{2}$ (n = 4, 8, 12, 16...)*2	$60 + 30 \frac{(n-4)}{2}$ (n = 4, 8, 12, 16...)*2	$70 + 30 \frac{(n-4)}{2}$ (n = 4, 8, 12, 16...)*2	

\*2 When "n" is an odd number, a multiple of 4 that is larger than the odd number is to be used for the calculation.

# Minimum Stroke for Auto Switch Mounting

## Center Trunnion

n: Number of auto switches [mm]

Auto switch model	Number of auto switches	ø32	ø40	ø50	ø63	ø80	ø100
D-G39 D-K39 D-A3□	2 (Different surfaces)	60	65	75	80	85	110
	2 (Same surface)	90	95	100	105	110	110
	n (Different surfaces)	$60 + 30(n-2)$ $(n=2, 4, 6, 8...)^*1$	$65 + 30(n-2)$ $(n=2, 4, 6, 8...)^*1$	$75 + 30(n-2)$ $(n=2, 4, 6, 8...)^*1$	$80 + 30(n-2)$ $(n=2, 4, 6, 8...)^*1$	$85 + 30(n-2)$ $(n=2, 4, 6, 8...)^*1$	$110 + 30(n-2)$ $(n=2, 4, 6, 8...)^*1$
	n (Same surface)	$90 + 100(n-2)$ $(n=2, 4, 6, 8...)^*1$	$95 + 100(n-2)$ $(n=2, 4, 6, 8...)^*1$	$100 + 100(n-2)$ $(n=2, 4, 6, 8...)^*1$	$105 + 100(n-2)$ $(n=2, 4, 6, 8...)^*1$	$110 + 100(n-2)$ $(n=2, 4, 6, 8...)^*1$	$110 + 100(n-2)$ $(n=2, 4, 6, 8...)^*1$
	1	60	65	75	80	85	110
D-A44	2 (Different surfaces)	70	75	80	85	85	110
	2 (Same surface)	70	75	80	85	85	110
	n (Different surfaces)	$70 + 30(n-2)$ $(n=2, 4, 6, 8...)^*1$	$75 + 30(n-2)$ $(n=2, 4, 6, 8...)^*1$	$80 + 30(n-2)$ $(n=2, 4, 6, 8...)^*1$	$85 + 30(n-2)$ $(n=2, 4, 6, 8...)^*1$	$85 + 30(n-2)$ $(n=2, 4, 6, 8...)^*1$	$110 + 30(n-2)$ $(n=2, 4, 6, 8...)^*1$
	n (Same surface)	$70 + 50(n-2)$ $(n=2, 4, 6, 8...)^*1$	$75 + 50(n-2)$ $(n=2, 4, 6, 8...)^*1$	$80 + 50(n-2)$ $(n=2, 4, 6, 8...)^*1$	$85 + 50(n-2)$ $(n=2, 4, 6, 8...)^*1$	$85 + 50(n-2)$ $(n=2, 4, 6, 8...)^*1$	$110 + 50(n-2)$ $(n=2, 4, 6, 8...)^*1$
	1	70	75	80	85	85	110
D-F5□/J59 D-F5□W D-J59W D-F5BA D-F59F	2 (Different surfaces, same surface)	90	95	110	115	120	120
	n (Same surface)	$90 + 55 \frac{(n-4)}{2}$ $(n=4, 8, 12, 16...)^*2$	$95 + 55 \frac{(n-4)}{2}$ $(n=4, 8, 12, 16...)^*2$	$110 + 55 \frac{(n-4)}{2}$ $(n=4, 8, 12, 16...)^*2$	$115 + 55 \frac{(n-4)}{2}$ $(n=4, 8, 12, 16...)^*2$	$120 + 55 \frac{(n-4)}{2}$ $(n=4, 8, 12, 16...)^*2$	$120 + 55 \frac{(n-4)}{2}$ $(n=4, 8, 12, 16...)^*2$
	1	90	95	110	115	120	120
D-F5NT	2 (Different surfaces, same surface)	100	105	120	125	130	130
	n (Same surface)	$100 + 55 \frac{(n-4)}{2}$ $(n=4, 8, 12, 16...)^*2$	$105 + 55 \frac{(n-4)}{2}$ $(n=4, 8, 12, 16...)^*2$	$120 + 55 \frac{(n-4)}{2}$ $(n=4, 8, 12, 16...)^*2$	$125 + 55 \frac{(n-4)}{2}$ $(n=4, 8, 12, 16...)^*2$	$130 + 55 \frac{(n-4)}{2}$ $(n=4, 8, 12, 16...)^*2$	$130 + 55 \frac{(n-4)}{2}$ $(n=4, 8, 12, 16...)^*2$
	1	100	105	120	125	130	130
D-A5□ D-A6□	2 (Different surfaces, same surface)	60	80	105	110	115	115
	1	60	80	105	110	115	115
D-A59W	n (Same surface)	$60 + 55 \frac{(n-4)}{2}$ $(n=4, 8, 12, 16...)^*2$	$70 + 55 \frac{(n-4)}{2}$ $(n=4, 8, 12, 16...)^*2$	$85 + 55 \frac{(n-4)}{2}$ $(n=4, 8, 12, 16...)^*2$	$110 + 55 \frac{(n-4)}{2}$ $(n=4, 8, 12, 16...)^*2$	$115 + 55 \frac{(n-4)}{2}$ $(n=4, 8, 12, 16...)^*2$	$120 + 55 \frac{(n-4)}{2}$ $(n=4, 8, 12, 16...)^*2$
	1	60	70	85	110	115	120
	2 (Different surfaces, same surface)	60	70	85	110	115	120
D-Y59□ D-Y7P D-Y7□W D-Z7□ D-Z80	2 (Different surfaces, same surface)	80	85	90	95	100	100
	1	80	85	90	95	100	100
	n	$80 + 40 \frac{(n-4)}{2}$ $(n=4, 8, 12, 16...)^*2$	$85 + 40 \frac{(n-4)}{2}$ $(n=4, 8, 12, 16...)^*2$	$90 + 40 \frac{(n-4)}{2}$ $(n=4, 8, 12, 16...)^*2$	$95 + 40 \frac{(n-4)}{2}$ $(n=4, 8, 12, 16...)^*2$	$100 + 40 \frac{(n-4)}{2}$ $(n=4, 8, 12, 16...)^*2$	$100 + 40 \frac{(n-4)}{2}$ $(n=4, 8, 12, 16...)^*2$
D-Y69□ D-Y7PV D-Y7□WV	2 (Different surfaces, same surface)	60	65	70	75	85	85
	1	60	65	70	75	85	85
	n	$60 + 30 \frac{(n-4)}{2}$ $(n=4, 8, 12, 16...)^*2$	$65 + 30 \frac{(n-4)}{2}$ $(n=4, 8, 12, 16...)^*2$	$70 + 30 \frac{(n-4)}{2}$ $(n=4, 8, 12, 16...)^*2$	$75 + 30 \frac{(n-4)}{2}$ $(n=4, 8, 12, 16...)^*2$	$85 + 30 \frac{(n-4)}{2}$ $(n=4, 8, 12, 16...)^*2$	$85 + 30 \frac{(n-4)}{2}$ $(n=4, 8, 12, 16...)^*2$
D-Y7BA	2 (Different surfaces, same surface)	85	90	100	105	110	110
	1	85	90	100	105	110	110
	n	$85 + 45 \frac{(n-4)}{2}$ $(n=4, 8, 12, 16...)^*2$	$90 + 45 \frac{(n-4)}{2}$ $(n=4, 8, 12, 16...)^*2$	$100 + 45 \frac{(n-4)}{2}$ $(n=4, 8, 12, 16...)^*2$	$105 + 45 \frac{(n-4)}{2}$ $(n=4, 8, 12, 16...)^*2$	$110 + 45 \frac{(n-4)}{2}$ $(n=4, 8, 12, 16...)^*2$	$110 + 45 \frac{(n-4)}{2}$ $(n=4, 8, 12, 16...)^*2$
D-P3DWA	2 (Different surfaces, same surface)	80	85	90	95	95	95
	1	80	85	90	95	95	95
	n	$80 + 50 \frac{(n-4)}{2}$ $(n=4, 8, 12, 16...)^*2$	$85 + 50 \frac{(n-4)}{2}$ $(n=4, 8, 12, 16...)^*2$	$90 + 50 \frac{(n-4)}{2}$ $(n=4, 8, 12, 16...)^*2$	$95 + 50 \frac{(n-4)}{2}$ $(n=4, 8, 12, 16...)^*2$	$95 + 50 \frac{(n-4)}{2}$ $(n=4, 8, 12, 16...)^*2$	$95 + 50 \frac{(n-4)}{2}$ $(n=4, 8, 12, 16...)^*2$
D-P4DW	2 (Different surfaces, same surface)	120	130	140	140	140	140
	1	120	130	140	140	140	140
	n	$120 + 65 \frac{(n-4)}{2}$ $(n=4, 8, 12, 16...)^*2$	$130 + 65 \frac{(n-4)}{2}$ $(n=4, 8, 12, 16...)^*2$	$140 + 65 \frac{(n-4)}{2}$ $(n=4, 8, 12, 16...)^*2$	$140 + 65 \frac{(n-4)}{2}$ $(n=4, 8, 12, 16...)^*2$	$140 + 65 \frac{(n-4)}{2}$ $(n=4, 8, 12, 16...)^*2$	$140 + 65 \frac{(n-4)}{2}$ $(n=4, 8, 12, 16...)^*2$

- \*1 When "n" is an odd number, an even number that is one larger than the odd number is to be used for the calculation.
- \*2 When "n" is an odd number, a multiple of 4 that is larger than the odd number is to be used for the calculation.

Other than the applicable auto switches listed in "How to Order", the following auto switches are mountable. Refer to the Web Catalog or Best Pneumatics for the detailed specifications.

Type	Model	Electrical entry	Features
Solid state	D-M9NV/M9PV/M9BV	Grommet (Perpendicular)	—
	D-Y69A/Y69B/Y7PV		Diagnostic indication (2-color indicator)
	D-M9NWV/M9PWV/M9BWW		Water resistant (2-color indicator)
	D-Y7NWV/Y7PWV/Y7BWW		Magnetic field resistant (2-color indicator)
	D-M9NAV/M9PAV/M9BAV		—
	D-P3DW		—
	D-P4DW		—
	D-F59/F5P/J59	Grommet (In-line)	—
	D-Y59A/Y59B/Y7P		Diagnostic indication (2-color indicator)
	D-Y7H		Water resistant (2-color indicator)
	D-F59W/F5PW/J59W		With timer
	D-Y7NW/Y7PW/Y7BW		Magnetic field resistant (2-color indicator)
	D-F5BA/Y7BA		—
	D-F5NT		—
D-P5DW	—		
Reed	D-A93V/A96V	Grommet (Perpendicular)	Without indicator light
	D-A90V	—	—
	D-A53/A56/Z73/Z76	Grommet (In-line)	Without indicator light
	D-A67/Z80		Without indicator light

- \* With pre-wired connector is also available for solid state switches. For details, refer to the Web Catalog or Best Pneumatics.
- \* Normally closed (NC = b contact) solid state auto switches (D-F9G/F9H/Y7G/Y7H) are also available. For details, refer to the Web Catalog or Best Pneumatics.



### 3-4. Wiring method and examples of auto switches

#### Sink Input Specifications

3-wire, NPN

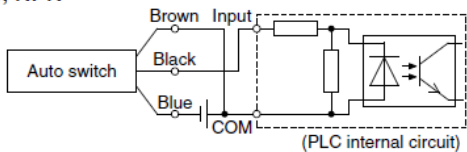

2-wire

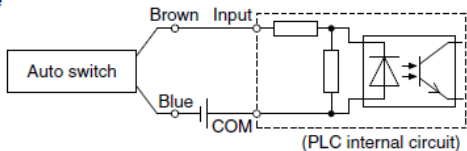

#### Source Input Specifications

3-wire, PNP

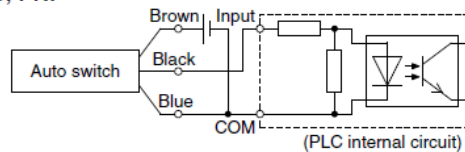

2-wire

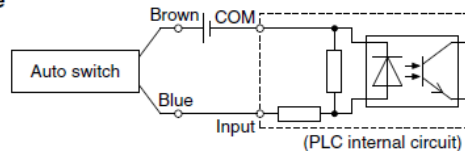

Connect according to the applicable PLC input specifications, as the connection method will vary depending on the PLC input specifications.

#### Examples of AND (Series) and OR (Parallel) Connections

\* When using solid state auto switches, ensure the application is set up so the signals for the first 50 ms are invalid.

##### 3-wire AND connection for NPN output

(Using relays)

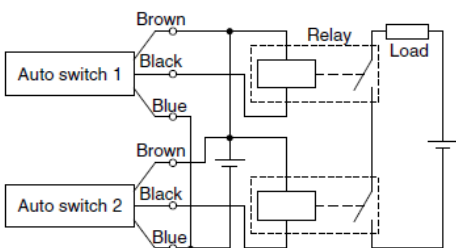

(Performed with auto switches only)

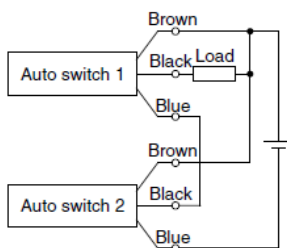

##### 3-wire OR connection for NPN output

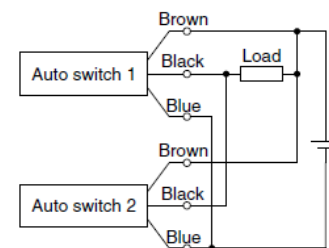

##### 3-wire AND connection for PNP output

(Using relays)

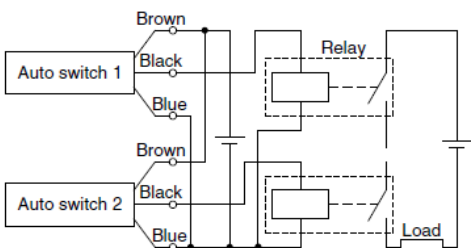

(Performed with auto switches only)

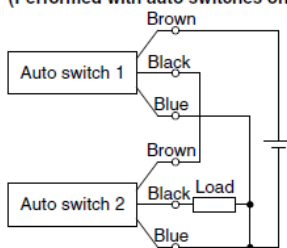

##### 3-wire OR connection for PNP output

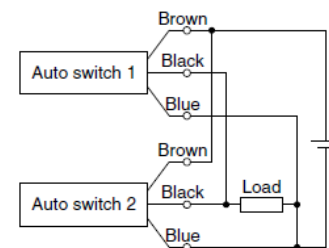

##### 2-wire AND connection

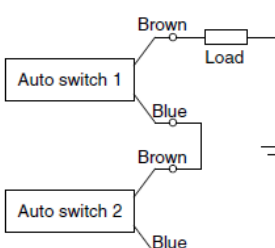

When two auto switches are connected in series, a load may malfunction because the load voltage will decline when in the ON state. The indicator lights will light up when both of the auto switches are in the ON state. Auto switches with a load voltage less than 20 V cannot be used.

$$\begin{aligned} \text{Load voltage at ON} &= \text{Power supply voltage} - \\ &\quad \text{Residual voltage} \times 2 \text{ pcs.} \\ &= 24 \text{ V} - 4 \text{ V} \times 2 \text{ pcs.} \\ &= 16 \text{ V} \end{aligned}$$

Example: Power supply is 24 VDC  
Internal voltage drop in auto switch is 4 V.

##### 2-wire OR connection

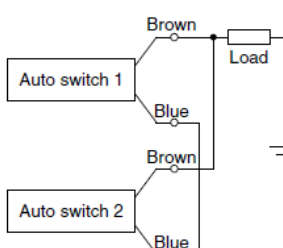

(Solid state)  
When two auto switches are connected in parallel, malfunction may occur because the load voltage will increase when in the OFF state.

(Reed)  
Because there is no current leakage, the load voltage will not increase when turned OFF. However, depending on the number of auto switches in the ON state, the indicator lights may sometimes grow dim or not light up, due to the dispersion and reduction of the current flowing to the auto switches.

$$\begin{aligned} \text{Load voltage at OFF} &= \text{Leakage current} \times 2 \text{ pcs.} \times \\ &\quad \text{Load impedance} \\ &= 1 \text{ mA} \times 2 \text{ pcs.} \times 3 \text{ k}\Omega \\ &= 6 \text{ V} \end{aligned}$$

Example: Load impedance is 3 kΩ.  
Leakage current from auto switch is 1 mA.

## 4. Maintenance

### 4-1. Consumable parts

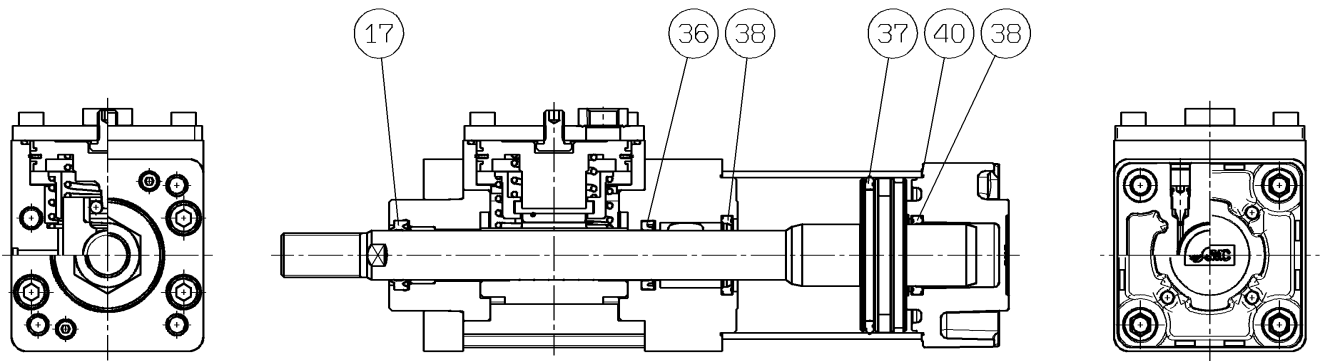

Fig. 14 Replaceable seals

#### 4-1-1. Seal kit

Bore size (mm)	Order No.	Operation
32	MWB32-PS	17: Rod seal 1 pc 36: Rod seal 1 pc 37: Piston seal 1 pc 38: Cushion seal 2 pcs 40: Cylinder tube gasket 2 pcs
40	MWB40-PS	
50	MWB50-PS	
63	MWB63-PS	
80	MWB80-PS	
100	MWB100-PS	

\* Lock part is replaced as an entire unit.

The seal kit for replacement contains the rod seal for the cylinder and lock.

Order the seal kit suitable for the cylinder bore size.

\* Grease pack is included in the seal kit shown above.

(10g for Ø32, Ø 40, Ø50. 20g for Ø 63, Ø80, Ø100)

If only the grease pack is required, order using the following part number.

Part number for grease: GR-S-010 (10g), GR-S-020 (20g)

#### Caution

- The seal is not delivered in sealed packaging for independent storage, so it must be used within 1 year.

#### 4-1-2. Storage of seals

#### Caution

- Store seals in sealed packaging such as polyethylene bag and place it in a box.
- Avoid locations exposed to direct sunlight, high temperature and humidity. In particular, isolate them from equipment that can generate heat, radiation and ozone.
- Do not stack a lot of seals, or deform or damage seals by putting a heavy object on top of them.
- White particles can emerge from the surface of the rubber part during storage, but they do not affect performance.

## 4-2. Lock unit replacement

### Caution

- ① Lock unit is replaceable. When ordering the lock unit for maintenance, select the suitable lock referring to the table below

Tube (mm)	Port type	Lock unit Order No.
32	Rc	MWB32-UA
	NPT	MWB32TN-UA
	G	MWB32TF-UA
40	Rc	MWB40-UA
	NPT	MWB40TN-UA
	G	MWB40TF-UA
50	Rc	MWB50-UA
	NPT	MWB50TN-UA
	G	MWB50TF-UA
63	Rc	MWB63-UA
	NPT	MWB63TN-UA
	G	MWB63TF-UA
80	Rc	MWB80-UA
	NPT	MWB80TN-UA
	G	MWB80TF-UA
100	Rc	MWB100-UA
	NPT	MWB100TN-UA
	G	MWB100TF-UA

\* For lock unit with bellows, please add -J to the part number suffix. Ex.) MWB50-UA-J

### ② Lock unit replacement

- 1) To release the lock state, screw-in the lock release bolt to the body cap end or pressurize the lock release port with 0.3MPa or more.

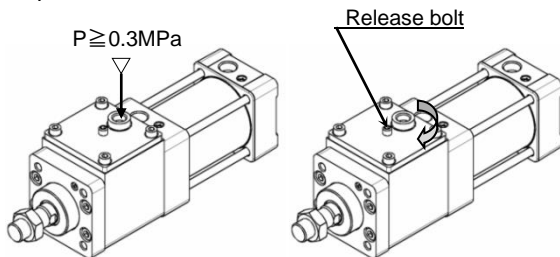

a) Lock released by air pressure

b) Manual lock release

- 2) Remove the lock unit holding bolt (hexagon socket head cap screw) on the rod side of the cylinder with hexagon wrench. Refer to the table below for the hexagon wrench. If using the rod end nut, please remove it.

Bore size (mm)	Hexagon wrench size of the lock holding bolt
32	3
40·50	5
63	6
80	8
100	10

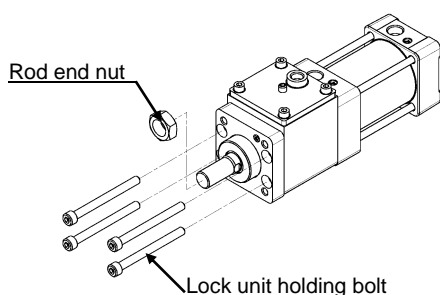

- 3) Pull out the old lock unit from the cylinder.

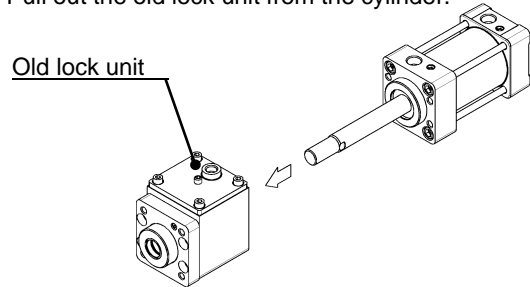

- 4) Insert a new lock unit into the cylinder.  
2) The lock unit for maintenance is supplied with lock released state at the shipment from the factory.

Note)  
Do not lock and operate the lock unit the lock unit has been mounted to the cylinder.

If the lock unit is operated before the rod has been inserted, the lock may not release properly and it will be difficult to insert the rod.

### New lock unit

(Condition: when shipped out from the factory: Lock released state)

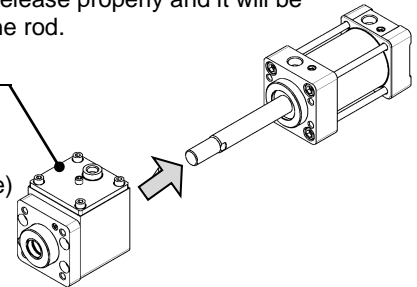

- 5) Insert the lock unit holding bolt and tighten it temporarily. Check that the piston rod operates smoothly by hand while maintaining the lock release state.

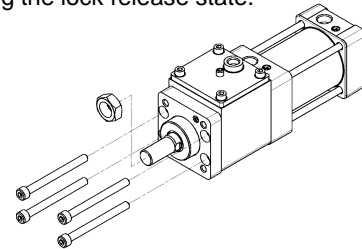

- 6) Confirm that the operation of 5) is performed correctly, and then tighten the lock unit holding bolt with an appropriate tightening torque as shown in the table below.

Tube I. D. (mm)	Appropriate tightening torque of the lock unit holding bolt (N·m)
32	1.35 to 1.65
40·50	4.7 to 5.7
63	11.3 to 13.7
80	22.1 to 26.9
100	37.8 to 46.2

- 7) After assembly is completed, rotate the release bolt anti-clockwise by hand with a hexagon wrench until resistance is felt. Once that position is reached, rotate it for an additional 1/6th of a turn to securely tighten the release bolt.

Note) Please do not use an electric driver or pneumatic driver.

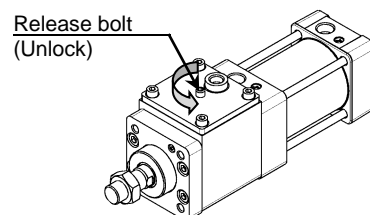

Check that the cylinder is locked and confirm that the lock is released when air pressure of 0.3MPa or more is applied to the lock unit release port. In addition to this, the piston rod should operate smoothly with the minimum operating pressure. Check that there is no air leakage from the release bolt.

## 4-3 Checks

### 4-3-1. Inspection points

- ① Tightness of the mounting bolt (hexagon socket head cap screw) between the lock unit and cylinder.
- ② Operation of the lock unit. Overrun and the stopping accuracy.
- ③ Tightness of mounting bolts and nuts of the cylinder and support brackets.
- ④ Connecting condition of the end bracket of the piston rod and workload.
- ⑤ Smooth operation of the cylinder. (with the lock released)
- ⑥ Change of the cylinder speed and cycle time.
- ⑦ Internal and external leakage.
- ⑧ Scratches, dent and deformation on the piston rod
- ⑨ Abnormal change in the cylinder stroke.

When any abnormality is found as a result of the inspections shown above, eliminate the causes and take necessary measures such as retightening screws, replacement of maintenance part, and repair. Contact SMC sales if the cylinder needs to be repaired.

### 4-3-2. Inspection interval

To use the Series MWB series cylinder with lock in the best condition, inspection needs to be performed once or twice a year.



#### **Warning**

**•Maintenance should be performed according to the items above. Perform additional inspections as necessary.**

Improper handling can cause damage or malfunction of equipment and machinery.

**•Removal of equipment and supply/exhaust of compressed air**

When equipment is removed, first confirm that measures are in place to prevent work piece from dropping and/or equipment running away, etc. Cut the supply pressure and electric power and exhaust all compressed air from the system. Before restarting the equipment, confirm that measures are taken to prevent sudden action.



#### **Caution**

**To avoid the reduction of the holding force, do not apply too much grease or oil to the piston rod surface. (MWB series does not require additional lubricant)**

## 4-4. Replacement of seals

The rod seal, cushion seal, piston seal, and cylinder tube gasket are replaceable.

Contact SMC sales if it is necessary to replace parts other than those mentioned above.



#### **Warning**

**•Only people who have sufficient knowledge and experience are allowed to replace seals.**

The person who disassembles and reassembles the cylinder is responsible for the safety of the product.



#### **Caution**

**•When replacing seals, take care not to hurt your hand or finger on the corners of parts.**

#### 4-4-1. Disassembly / Reassembly

The cylinder can be disassembled by loosening the tie-rod nuts.

#### Caution

- Disassemble and reassemble the cylinder in a clean location. Perform all changes on a clean cloth.
- Make sure no particles are present. Do not scratch the seals.
- To assemble the tie-rods in the cylinder, tighten the tie-rod nuts to the shorter screw side by hand.
- Set the tie rod nuts from the cover on the opposite side. Tighten the tie rod nut so that the tensile force is even. Refer to the appropriate tightening torque shown in the table below. Brackets refer to the same table. (P.40, 4) Refer to hexagon wrench size for the replacement of support brackets)

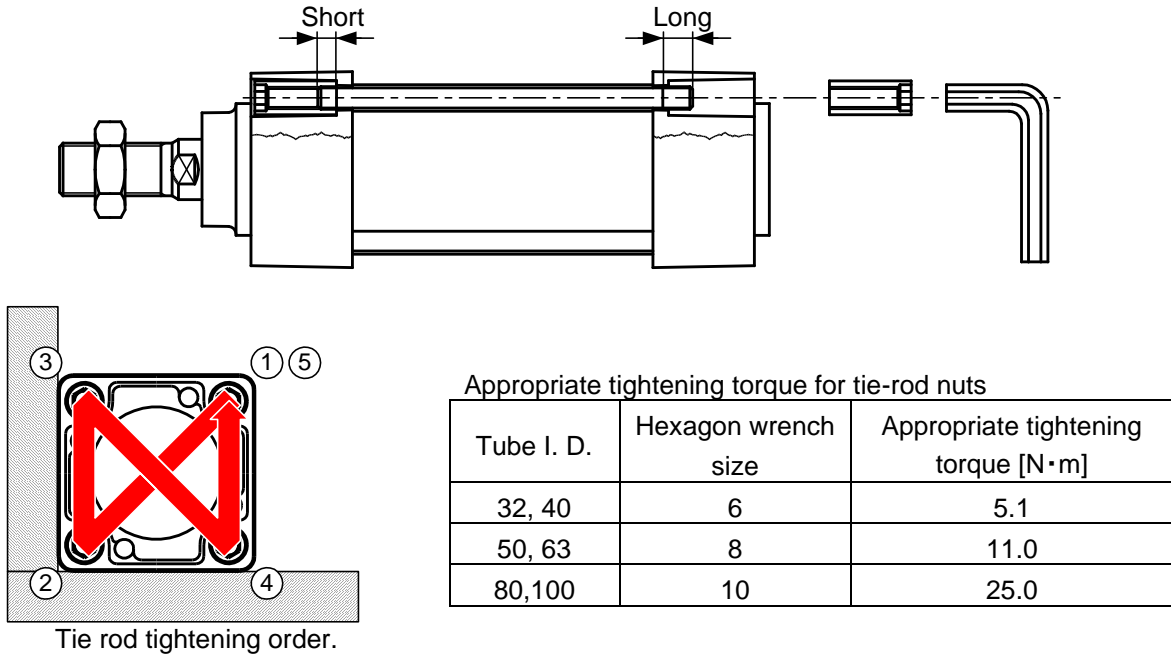

Fig.15 Tightening of tie-rod nuts

#### 4-4-2. Removal of seals

##### 1) Rod seal and cushion seal

Insert a precision screwdriver from the front of the cover to pull out the seal as shown in Fig. 16.

### **Caution**

**Take caution not to damage the seal groove of the cover at this time.**

##### 2) Piston seal

Wipe off grease around piston seal first to make seal removal easier.

As shown in Fig. 17, hold the piston seal with one hand and push it into the groove so that the piston seal can be lifted off and pulled out without using a precision screwdriver.

The groove of the piston is deep, so if the piston seal is removed with a precision screwdriver, it might be damaged.

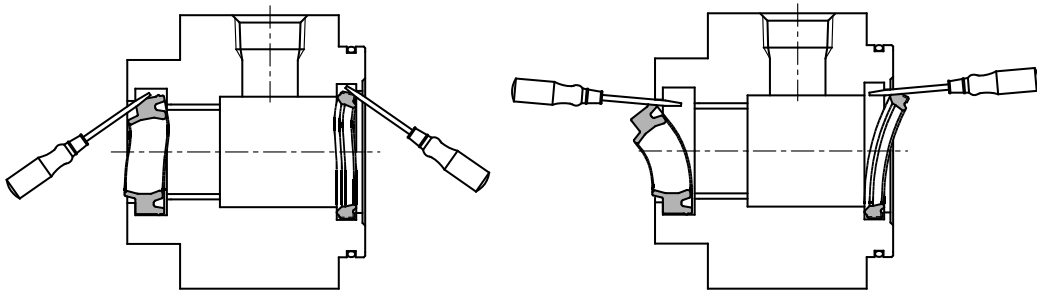

**Fig. 16 Removal of rod seal and cushion seal**

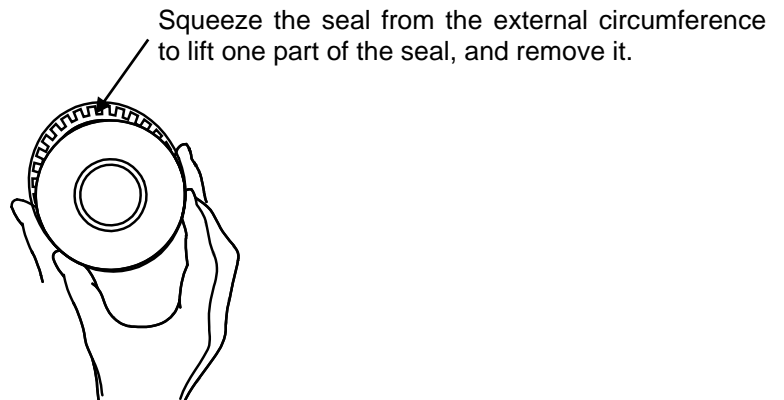

**Fig 17 How to remove piston seal**

##### 3) Tube gasket

Take out with the precision screwdriver.

### 4-4-3. Grease

#### Caution

•Use a specified grease.

Grease pack number: GR-S-010 (10g), GR-S-020 (20g)

1) Rod seal ①

Apply a thin layer of grease to all surfaces of the new seal to make it easy to install the rod seal and improve sealing.

Fill the groove of the seal with grease, which is necessary for operation.

2) Piston seal ②

Apply a thin layer of grease to the all surfaces of the piston seal to make it easy to install the seal.

3) Cushion seal ⑤, Tube gasket ⑦

Apply a thin layer of grease to all surfaces of the tube gasket to make it easy to install the gasket.

4) Parts of cylinder

Grease is applied to the locations shown in Figure 18. The amount of grease per cylinder of 100 mm stroke is shown in the table below. Roughly, one scoop with a forefinger is approximately 3g.

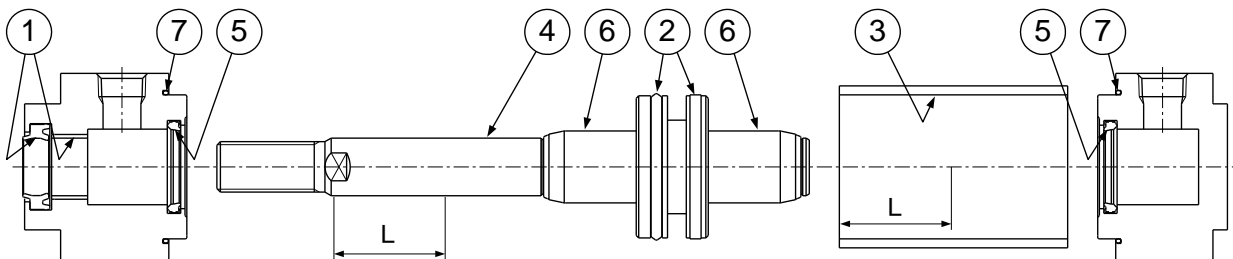
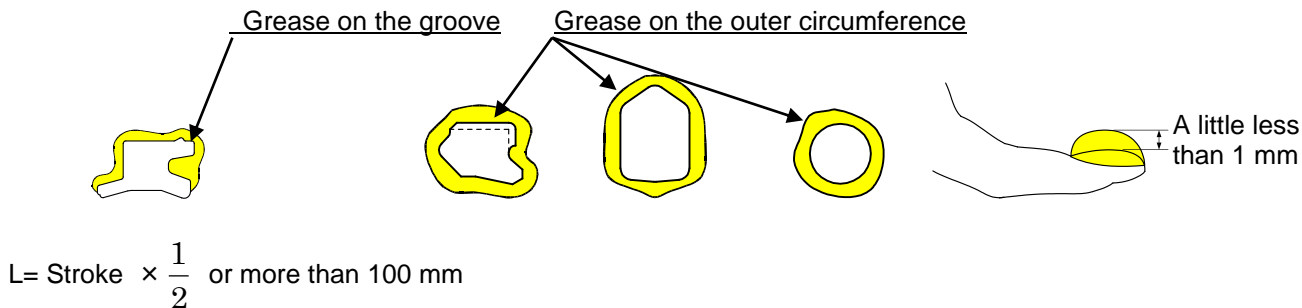

**Fig. 18 Position for application of grease**

Grease application amount

Unit: g

Stroke \ Bore size	Ø32	Ø40	Ø50	Ø63	Ø80	Ø100	Positions for application of grease
At 100st	3~4	3~4	3~5	4~5	6~8	8~10	① ② ③ ④ ⑤ ⑥ ⑦
50st added	1	1	1	1.5	2	3	③ ④

#### 4-4-4. Mounting of seals

- 1) Rod seal, cushion seal (① and ⑤ in Fig. 18)

Installing directions of the seal are specified.

Apply grease all over the seal and inner surface of the bushing as shown in Fig. 19. If it is difficult to apply grease due to a small bore size etc., use a precision screwdriver.

- 2) Piston seal (② in Fig. 18)

Install with care not to twist the piston seal. Apply grease to the seal groove and outer circumference by rubbing grease into them as shown in Fig. 20.

- 3) Tube gasket (⑦ in Fig. 18)

Install with care not to twist the tube gasket.

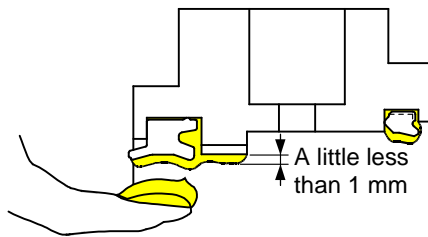

Fig. 19. Rod seal

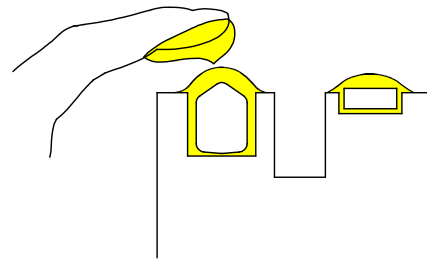

Fig. 20. Piston seal

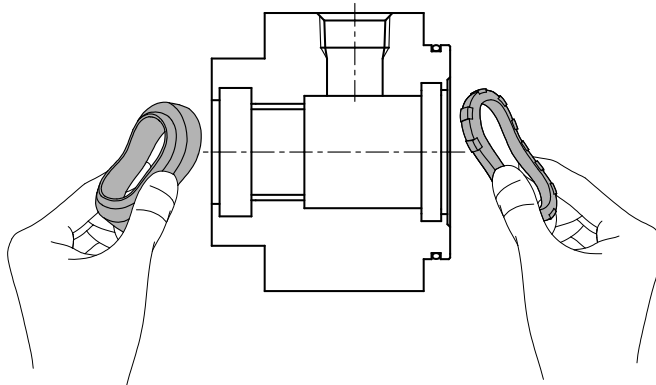

Fig. 21 Mounting of the rod seal and cushion seal

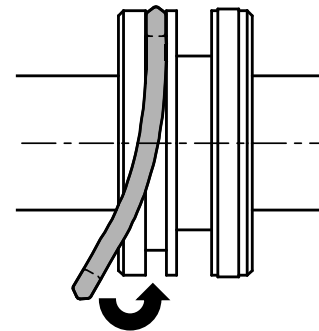

Fig. 22 Mounting of the piston seal

- 4) When the support brackets are replaced, use a hexagon wrench as specified below.

Bore size (mm)	Bolt	Hexagon wrench size	Tightening torque (Nm)
32, 40	MB-32-48-C1247	4	5.1
50, 63	MB-50-48-C1249	5	11
80, 100	Foot	MB-80-48AC1251	25
	Other	MB-80-48BC1251	

- 5) When replacing the support brackets, the tie-rod nuts on the cylinder body will be loosened.

Mount the support brackets after tightening the tie-rod nuts at the specified tightening torque.

- 6) Trunnion type cylinder requires a mounting accuracy.

Since the axis of trunnion is not aligned with the axis of cylinder easily, the trunnion type cylinder may lose the dimensional accuracy when it is disassembled or reassembled, leading to malfunction.

#### **Caution**

**Confirm that there is no problem in the operation and the air tightness after reassembly.**



## 5. Troubleshooting

### ① End lock cylinder

Reported failure	Major causes		Countermeasures
Lock is not released. Cylinder does not operate.	Check the lock unit and peripheral equipment.	① Air piping is not connected to the lock unit. Or air supplied to the lock unit is not adequate for operation.	Connect piping to the lock unit and supply 0.3MPa or more air.
		② Solenoid valve connected to the lock unit does not operate.	<ul style="list-style-type: none"> <li>•Check the power supply to the solenoid valve</li> <li>•Check that the wiring of the solenoid valve is correct.</li> <li>•Check that the piping of the solenoid valve is correct.</li> <li>•Check if air is supplied to the solenoid valve</li> <li>•Make sure that the solenoid valve is not in manual lock state.</li> </ul> No problems are confirmed with above. If the solenoid valve failure is confirmed, repair it or replace it.
		③ Solenoid valve for locking is energized and operated, but air is not supplied from the solenoid valve.	Check the solenoid valve type. If the solenoid valve is normal open type which shuts off air while the solenoid valve is energised, change it to normal close type which supplies air while the valve is energised.
		④ Air leakage from the manual lock release bolt.	Return the manual lock release bolt to the locking status. (Air leakage may occur if the manual lock release bolt is not returned to the correct lock position and status)
		⑤ No problems are confirmed in ① to ④ above, but lock is not released even when air is supplied to the lock unit.	It is possible that the inside of the lock unit is broken. Release the lock manually and replace the lock unit. If manual cannot be released manually, replace the product by cylinder. (Do not disassemble or repair. Contact SMC Sales office.)
Lock is released and cylinder does not operate smoothly.	Check the cylinder and peripheral equipment	① Air piping is not connected to the cylinder or air supplied to the lock unit is not adequate for cylinder operation. (Load factor is too high)	<ul style="list-style-type: none"> <li>•Check the air piping of the cylinder</li> <li>•Increase the operating pressure of the cylinder.</li> <li>•Use a larger cylinder.</li> </ul>
		② Speed controller mounted to the cylinder is fully closed.	Gradually open the speed controller from the fully closed position so that the cylinder travels full stroke smoothly at the optimum speed.
		③ Speed controller is meter-in control.	•Change it to meter-out control.
		④ Operation speed of the cylinder is below the limit of minimum speed.	<ul style="list-style-type: none"> <li>•Adjust the piston speed using a speed controller to keep the minimum operation speed or higher.</li> <li>•Remove the factor of load fluctuation.</li> </ul>
		⑤ Solenoid valve connected to the cylinder does not operate.	<ul style="list-style-type: none"> <li>•Check the power supply to the solenoid valve</li> <li>•Check that the wiring of the solenoid valve is correct.</li> <li>•Check that the piping of the solenoid valve is correct.</li> <li>•Check if air is supplied to the solenoid valve</li> <li>•Make sure that the solenoid valve is not in manual lock status.</li> </ul> No problems are confirmed with above. If the solenoid valve failure is confirmed, repair it or replace it.
		⑥ Mounting alignment is inadequate or affected by lateral load.	<ul style="list-style-type: none"> <li>•Align the product and make adjustment.</li> <li>• Install a guide to prevent excessive load from being applied to the cylinder.</li> <li>• Modify mounting conditions, change the support brackets.</li> </ul>
		⑦ External guide of the cylinder is distorted or warped.	Check the operating conditions to replace with the optimum type and size of the guide.
Locking Malfunction	Check the lock unit and peripheral equipment.	① Manual lock is released. (Check the condition of the lock release bolt)	Check the operating conditions to replace with the optimum type and size of the guide.
		② Air of the lock unit is not exhausted. (If the lock unit and solenoid valve for locking are installed too far, it is possible that air in the piping tube is not exhausted completely.)	<ul style="list-style-type: none"> <li>•Install the solenoid valve for locking close to the lock unit and shorten the piping tube or, directly connect them.</li> <li>•Install a quick exhaust valve close to the lock unit piping port.</li> </ul>
		③ Solenoid valve connected to the lock unit does not operate.	<ul style="list-style-type: none"> <li>•Check the power supply to the solenoid valve</li> <li>•Check that the wiring of the solenoid valve is correct.</li> <li>•Check that the piping of the solenoid valve is correct.</li> <li>•Check if air is supplied to the solenoid valve</li> <li>•Make sure that the solenoid valve is not in manual lock status.</li> </ul> No problems are confirmed with above. If the solenoid valve failure is confirmed, repair it or replace it.

Reported failure	Major causes		Countermeasures	
Locking Malfunction	Check the lock unit and peripheral equipment.	④	Solenoid valve for locking is de-energized, but air is supplied from the solenoid valve.	Check the solenoid valve type if it is normal open type. Change it to normal close type which supplies air while the valve is energized.
		⑤	No problems are confirmed in ① to ④ above, but locking is not possible even when air is supplied to the lock unit.	It is possible that the inside of the lock unit is broken. Replace the unit. (Do not disassemble or repair. Contact SMC Sales office.)
	Check the cylinder and peripheral equipment	①	Cylinder is too fast.	Decrease the speed by setting the speed controller.
		②	Load weight is too large. (Load factor is too high)	Confirm if the allowable kinetic energy is exceeded referring to the Selection Graph.
		③	Air circuit is not a recommended balanced circuit. (Excessive cylinder output is applied to the lock unit)	Connect air by recommended balanced circuit. (Refer to Page 15)
		④	Failure of the auto switch for signals for locking.	Check the auto switch wiring and operation. Replace the auto switch if it is broken.
⑤	[Proximity switch for locking is installed outside of the cylinder] Operation range of the proximity switch is exceeded.	<ul style="list-style-type: none"> <li>• Check the operation range of the proximity switch. (Change the switch to the auto switch with timer)</li> <li>• Change to proximity with self-holding circuit.</li> <li>• Revise the installation of the proximity switch and switch detector for redesign.</li> </ul>		
Large overrun. (Stopping accuracy is low)	Check the peripheral equipment of the lock unit.	①	Effective area of the solenoid valve for locking is too small.	Replace the solenoid valve to the one with larger effective area.
		②	Piping between the lock release port and the solenoid valve for locking is long or the piping diameter is small.	<ul style="list-style-type: none"> <li>• Install the solenoid valve for locking close to the lock unit and shorten the piping tube or, directly connect them.</li> <li>• Install a rapid exhaust valve close to the lock unit piping port.</li> </ul>
		③	Poor response of the solenoid valve for locking.	Replace the solenoid valve to the one with better response.
		④	Poor response of the solenoid valve for locking to the auto switch for signal detection.	Replace the switch with the auto switch with better response.
		⑤	[Proximity switch for locking is installed outside of the cylinder] There is a play with the switch detector of the proximity switch. The shape of switch detector is not suitable.	<ul style="list-style-type: none"> <li>• Adjust the switch detector to eliminate the play.</li> <li>• Redesign the switch detector.</li> </ul>
		⑥	AC is used for the electric circuit.	Change the circuit to DC type.
	Sudden extension of the rod when the lock is released.	a. The circuit is not balanced. b. Regulator for balancing pressure is not adjusted. c. Line pressure fluctuates. d. After stopping by locking, it is too fast to unlock.	a. Change to recommended balanced circuit. (Refer to Page 15) b. Adjust the regulator valve. Check if the locked status is balanced. c. Install an air tank so that pressure fluctuation does not occur when supplying air to the lock unit and cylinder. d. After stopping by locking, release the lock after waiting for 0.5sec or longer.	
	Cylinder speed changed	a. Misalignment of the piston rod and guide. b. High load rate of the cylinder. c. Stopping interval (pitch) is short. d. Stopping in the middle of cushioning process or immediately after the cushioning process. (When air cushion type is used) e. Line pressure fluctuates.	a. Adjust the alignment of the piston rod and guide or use the floating joint. b. Use a larger cylinder. c. Set the stop interval to 40mm or wider. d. Change the cylinder to rubber cushion type. e. Install an air tank so that pressure fluctuation does not occur when supplying air to the lock unit and cylinder.	
	Changes in the load.	a. Load varies continuously due to rotating movement. b. Load varies due to vertical load. (Step change)	a. Cylinder with lock is not suitable. Use the cylinder which use incompressible fluid such as air-hydro cylinder. b. When there is a step like change of the load, use a multi-stage pressure regulating valve for balancing pressure.	

## ② Cylinder part

Reported failure	Major causes	Countermeasures
Damage and/or deformation	Impact applied due to high speed operation.	<ul style="list-style-type: none"> <li>• Readjust the cushion.</li> <li>• Reduce the operating speed.</li> <li>• Reduce the load.</li> <li>• Mount an external impact absorbing mechanism. (Shock absorber, etc.)</li> </ul>
	Lateral load is applied.	<ul style="list-style-type: none"> <li>• Provide a proper guide.</li> <li>• Modify the mounting condition.</li> </ul>

## 6. Maintenance

### 6-1. Construction

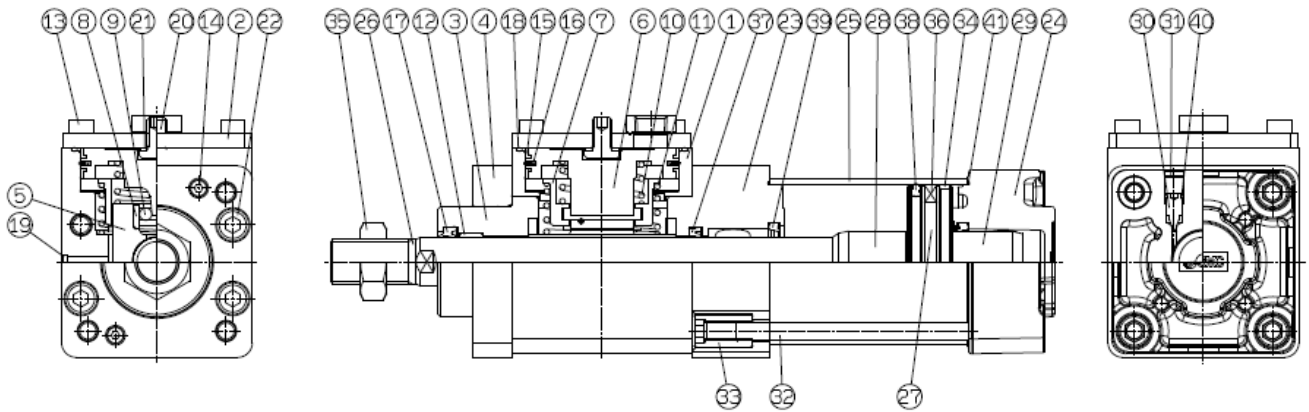

Fig. 23 Construction

No.	Description	Qty	Note
1	BRAKE BODY	1	
2	BODY CAP	1	
3	COLLAR	1	
4	HOLDER	1	
5	BRAKE METAL	1	
6	PISTON A	1	
7	ROLLER HOLDER	1	
8	ROLLER PLATE	2	
9	NEEDLE ROLLER	2	
10	PISTON SPRING	1	
11	ROLLER SPRING	1	
12	BUSHING	1	
13	HEXAGON SOCKET CAP BOLT	4	
14	HEXAGON SOCKET CAP BOLT	2	
15	WEAR RING A	2	
16	PISTON SEAL A	1	
17	ROD SEAL A	1	
18	GASKET	1	
19	ELEMENT	1	
20	RELEASE BOLT	1	

No.	Description	Qty	Note
21	SEAL WASHER	1	
22	HEXAGON SOCKET CAP BOLT	4	
23	ROD COVER	1	
24	HEAD COVER	1	
25	CYLINDER TUBE	1	
26	PISTON ROD	1	
27	PISTON B	1	
28	CUSHION RING	1	
29	CUSHION RING B	1	
30	CUSHION VALVE	2	
31	RETAINING RING	2	For Ø40 to Ø100
32	TIE ROD	4	
33	TIE ROD NUT	8	
34	WEAR RING B	1	
35	ROD END NUT	1	
36	MAGNET	(1)	For MDWB
37	ROD SEAL B	1	
38	PISTON SEAL B	1	
39	CUSHION SEAL	2	
40	CUSHION VALVE SEAL	2	
41	CYLINDER TUBE GASKET	2	

#### Revision history

- A: Added  $\phi$  80 and  $\phi$  100.
- 2: "Safety Instructions" revised,  
4-2. Lock unit replacement: Added precautions  
Corrected the contents of warnings and cautions.

## SMC Corporation

Tel: + 81 3 5207 8249 Fax: +81 3 5298 5362  
URL <https://www.smcworld.com>

---

Note: Specifications are subject to change without prior notice and any obligation on the part of the manufacturer.  
© SMC Corporation All Rights Reserved